



World Racers



8898



LEGO 3

1

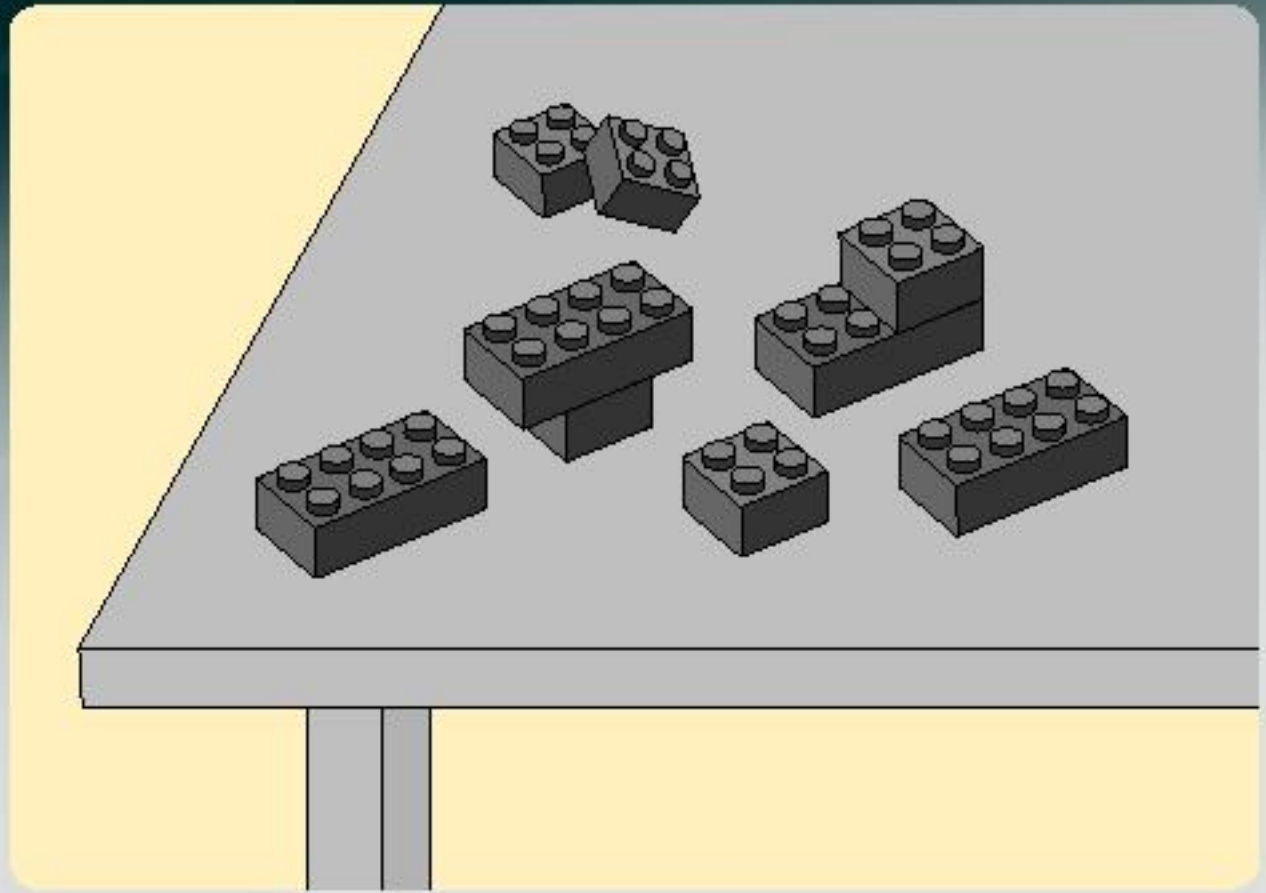
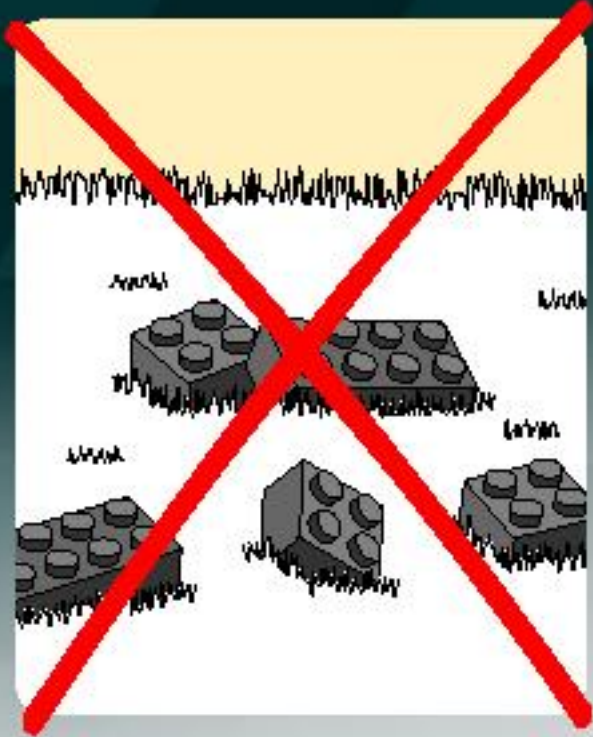

2

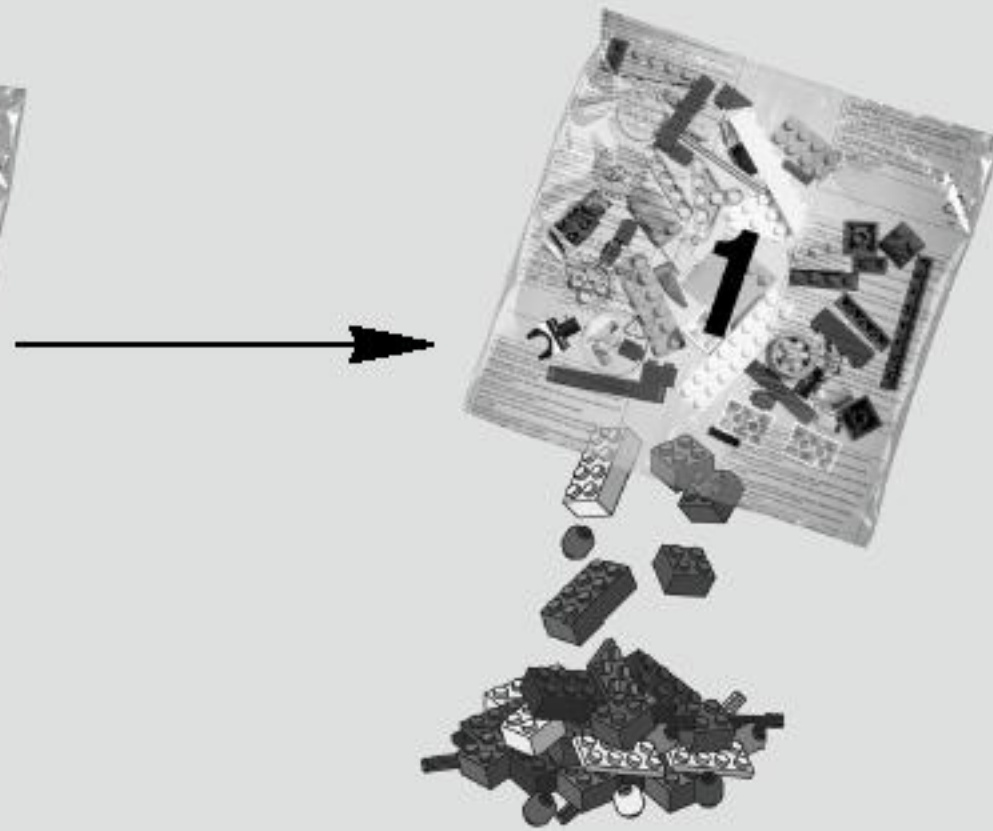

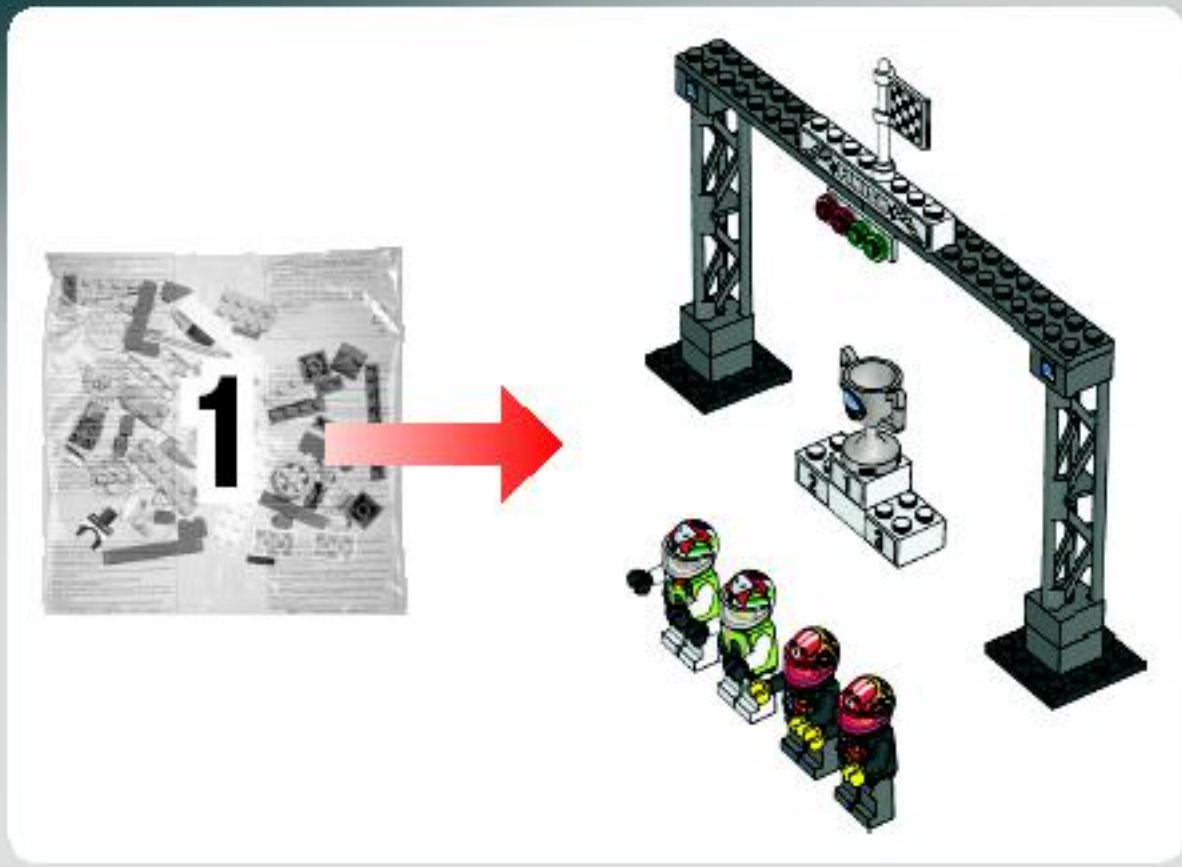

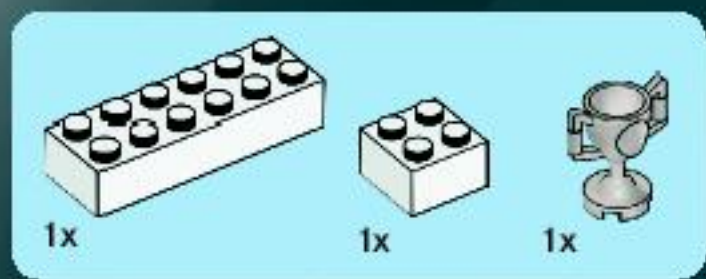

1

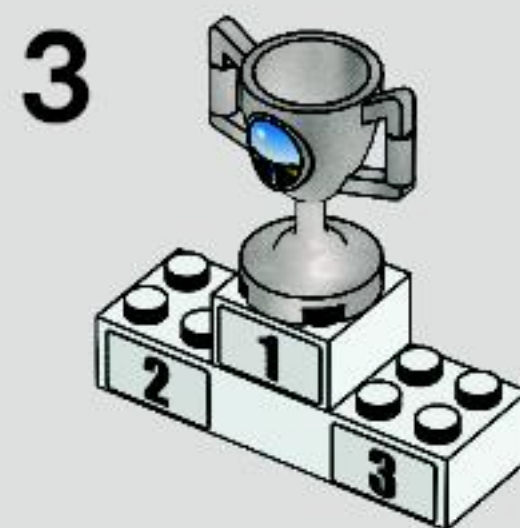
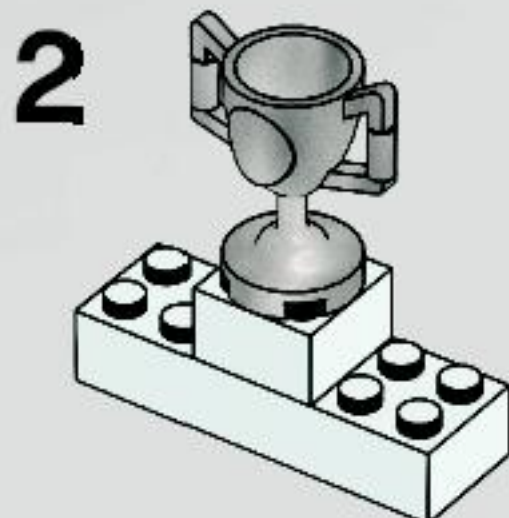
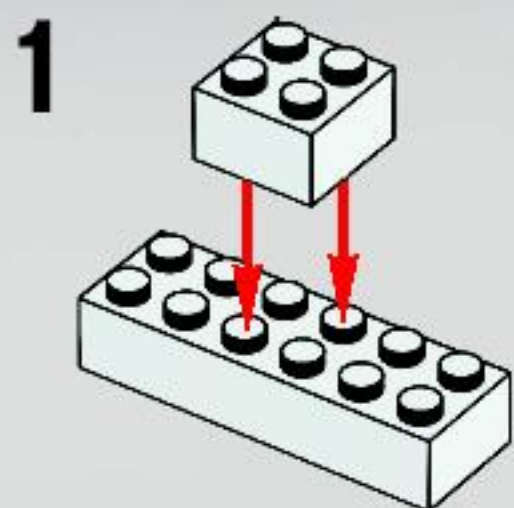

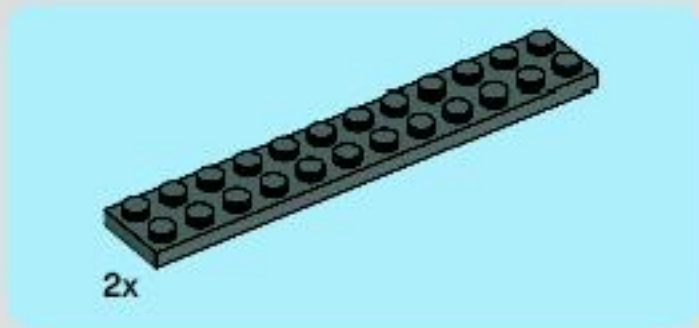
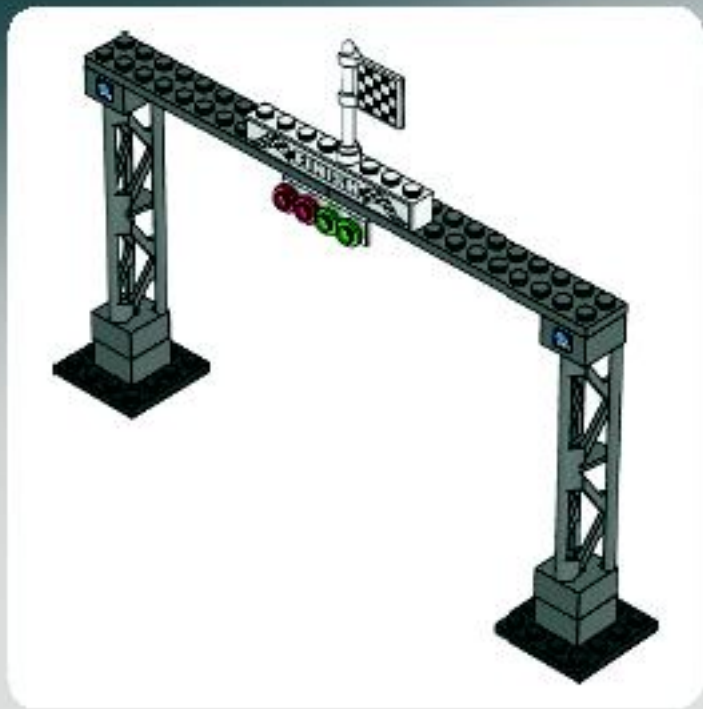

1

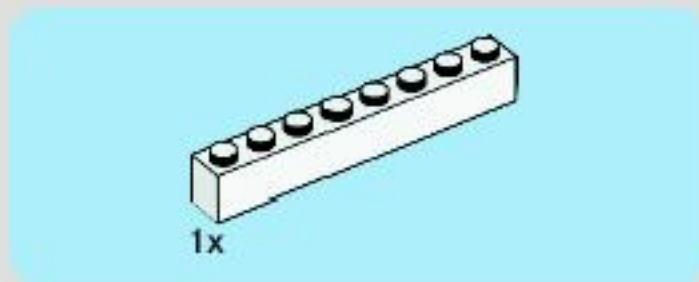
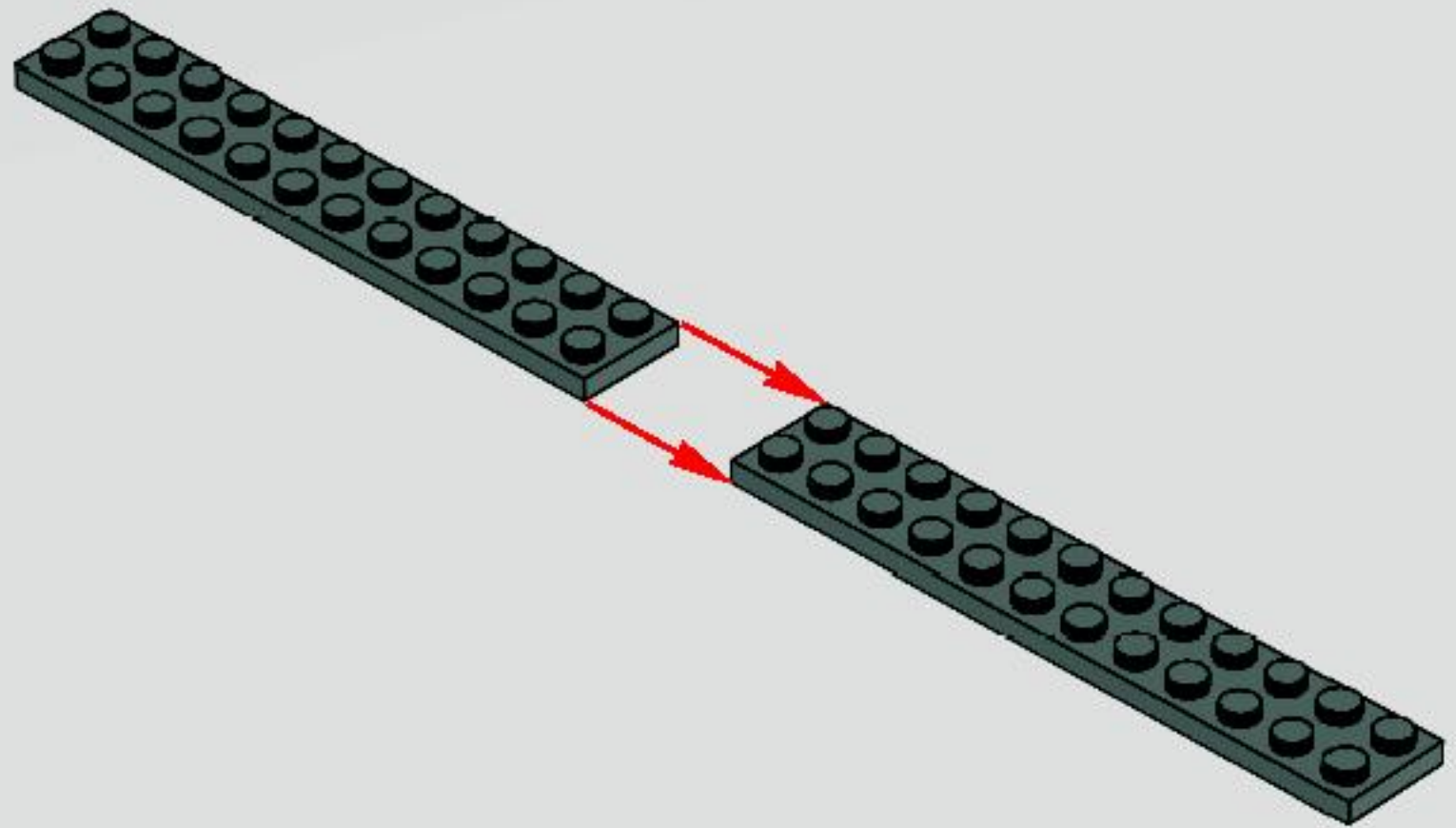

2

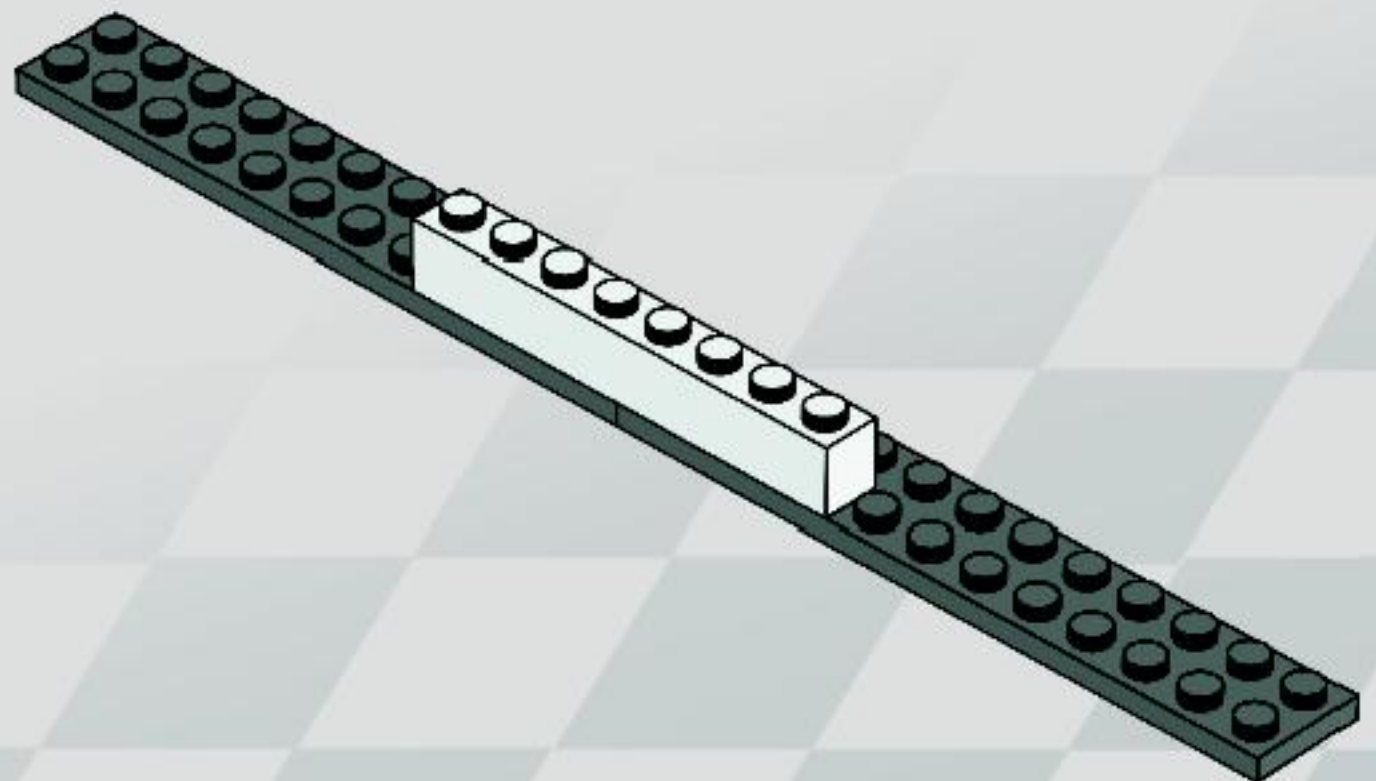



3

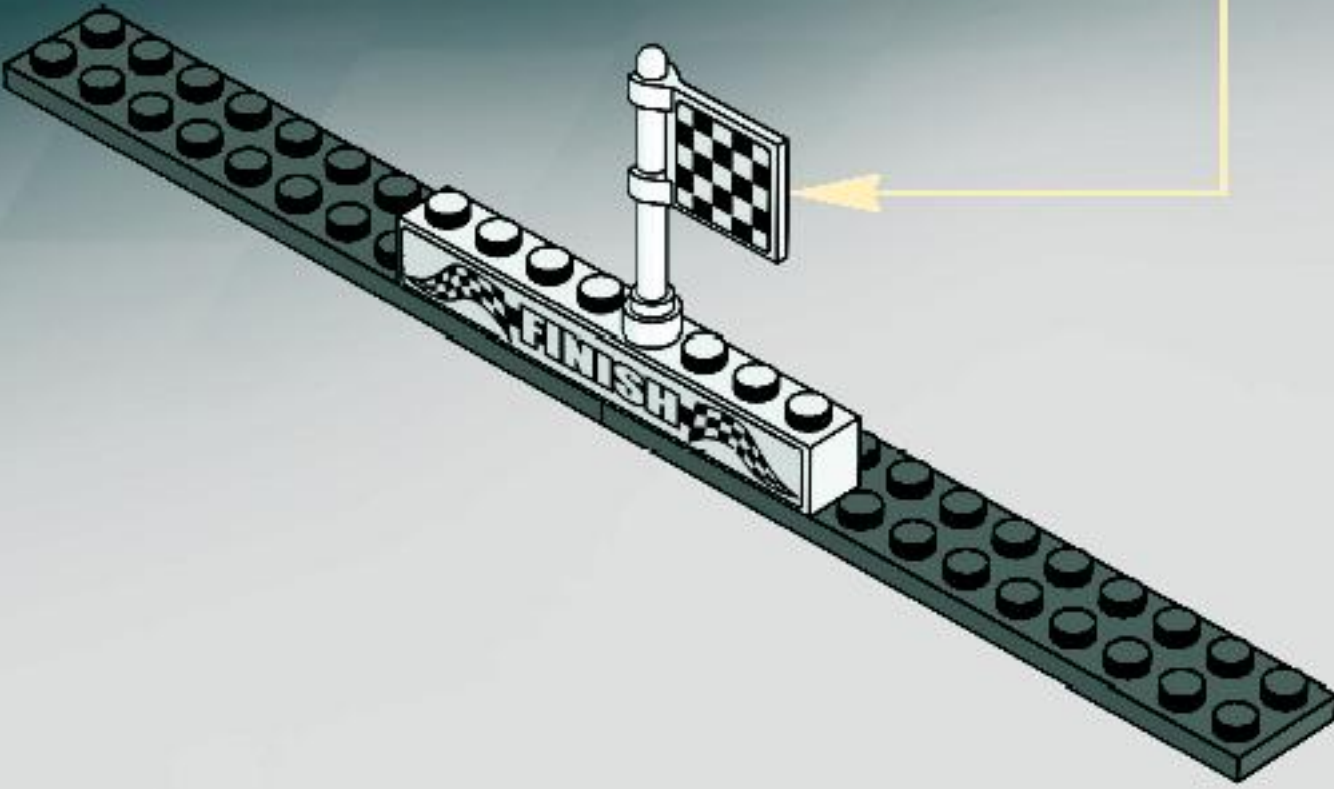
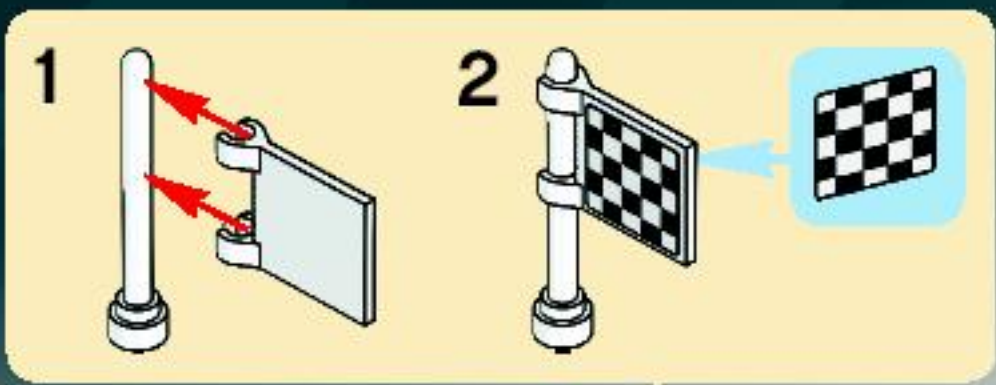

4

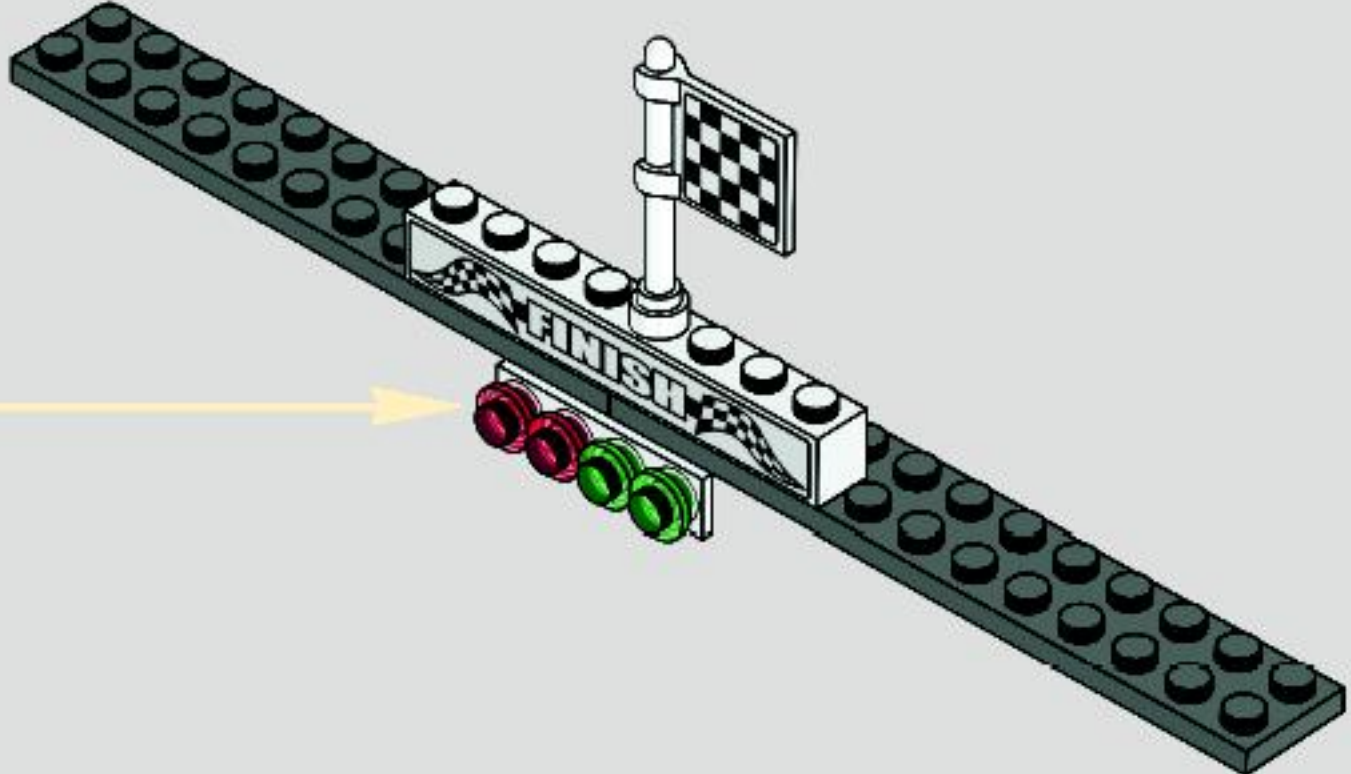
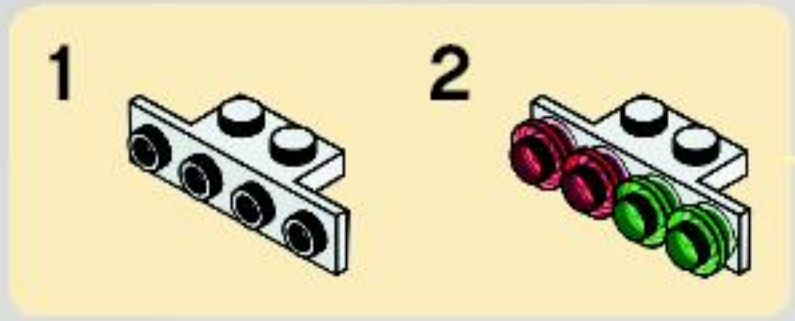

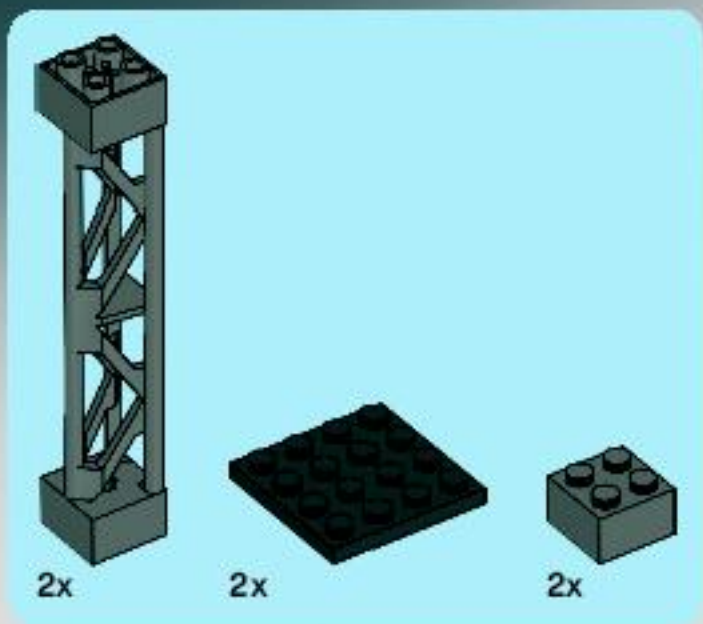

5

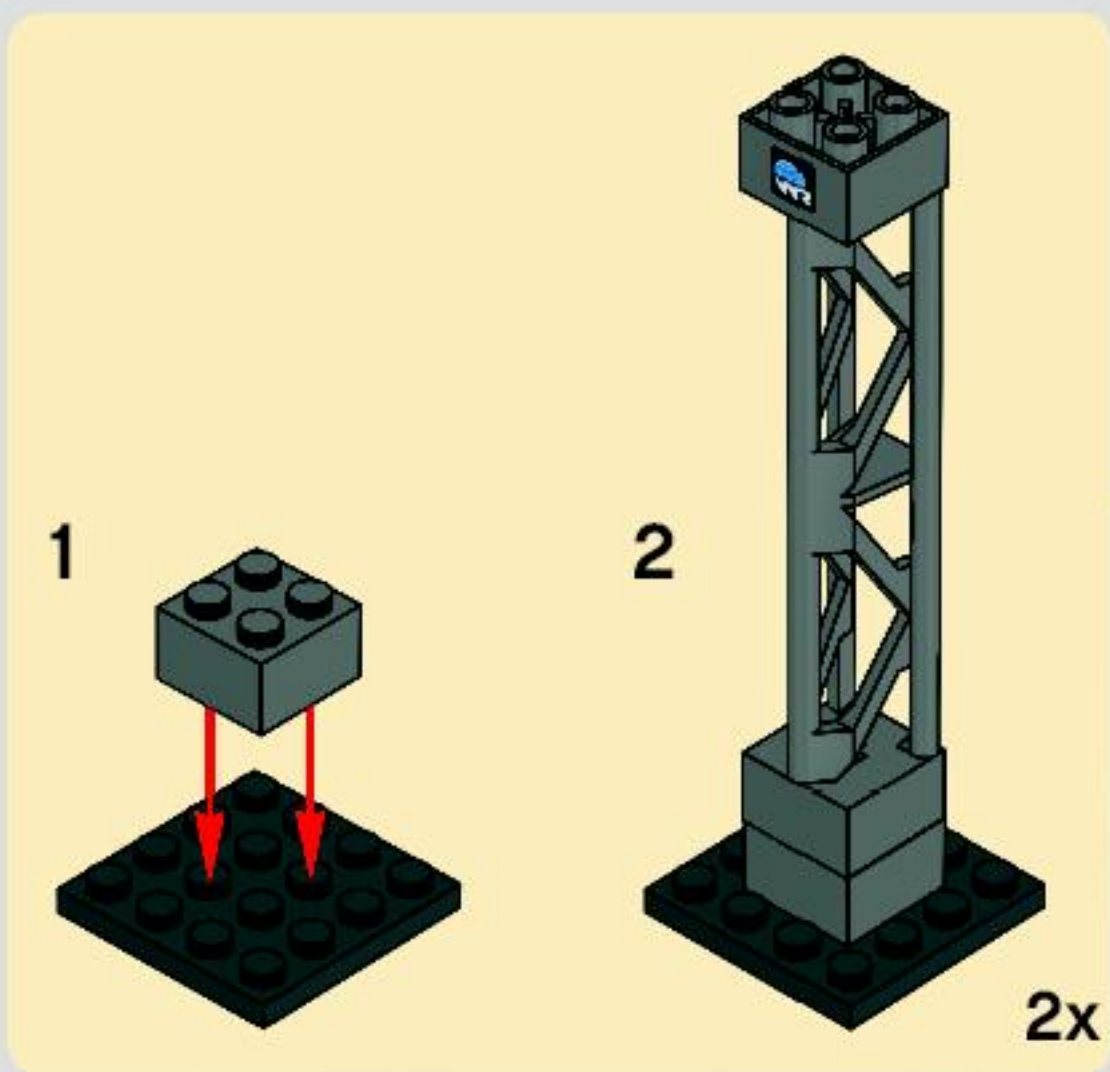
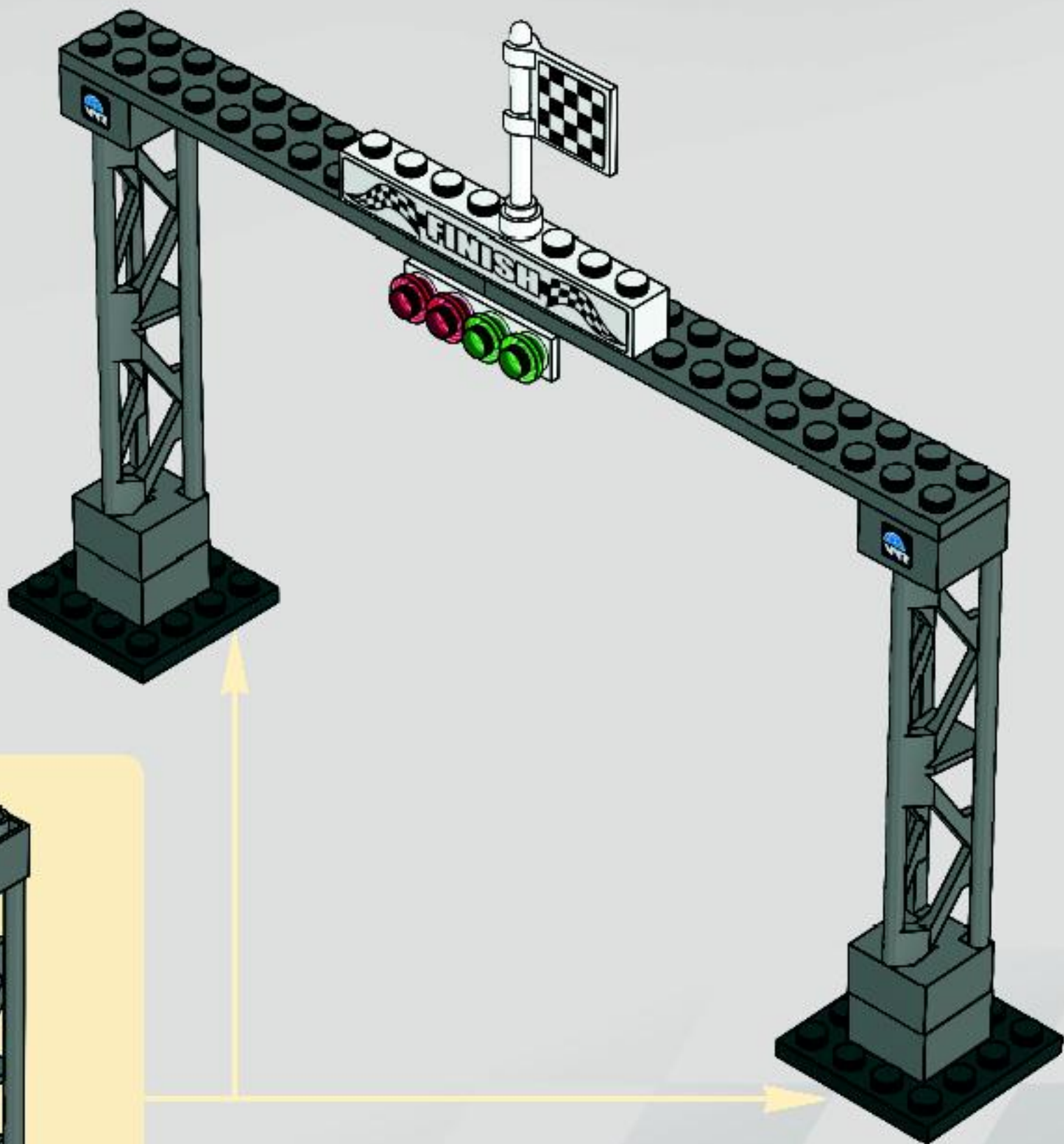

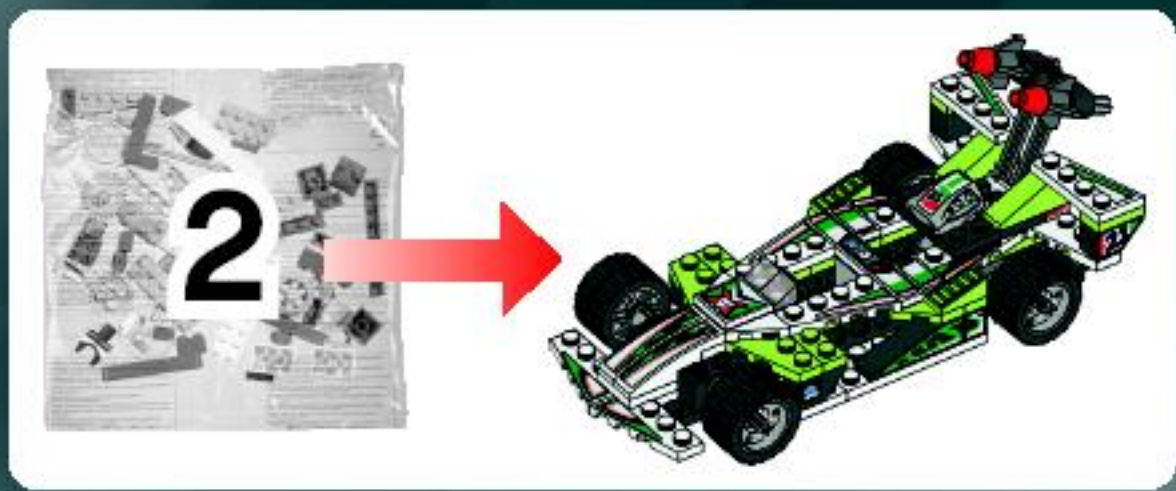

1

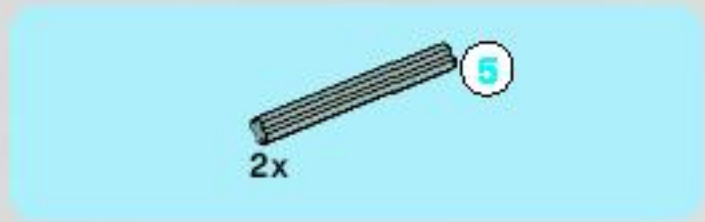

2

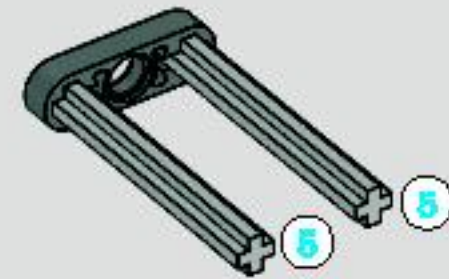



3



4





5

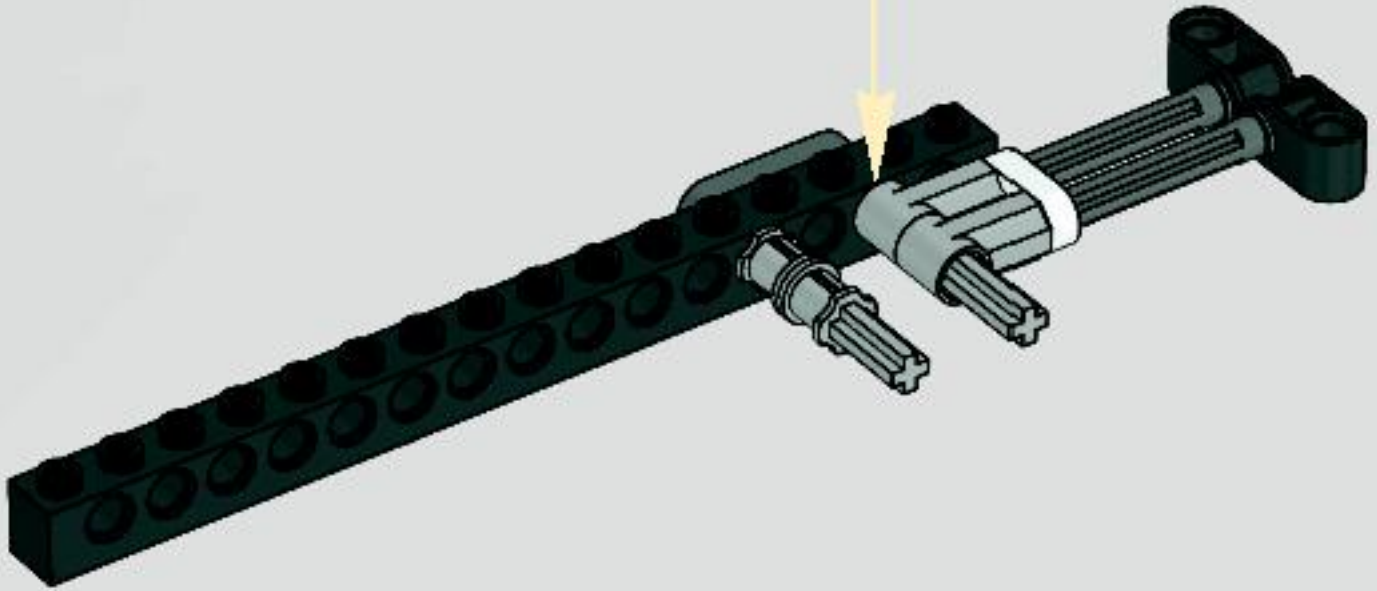
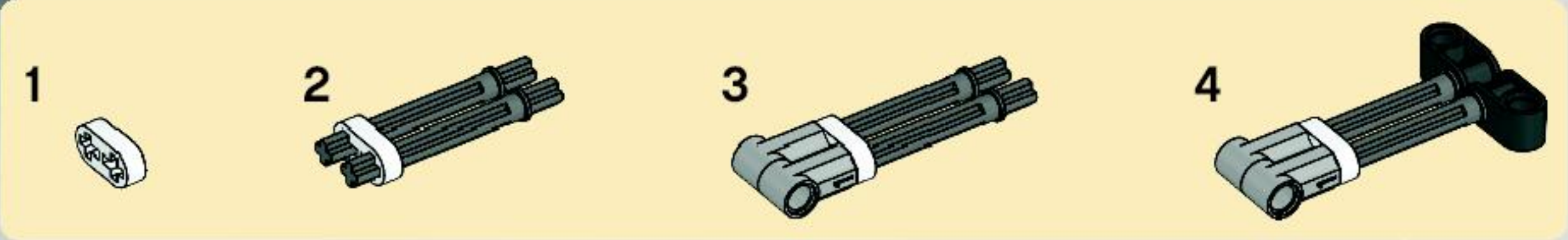



6

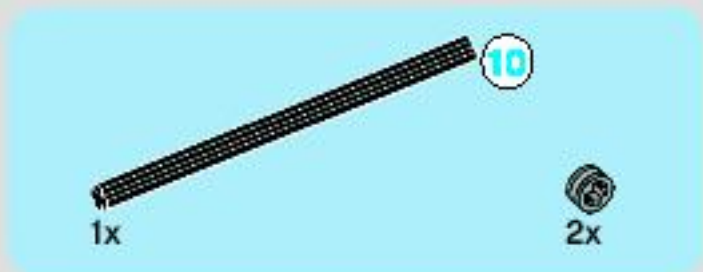
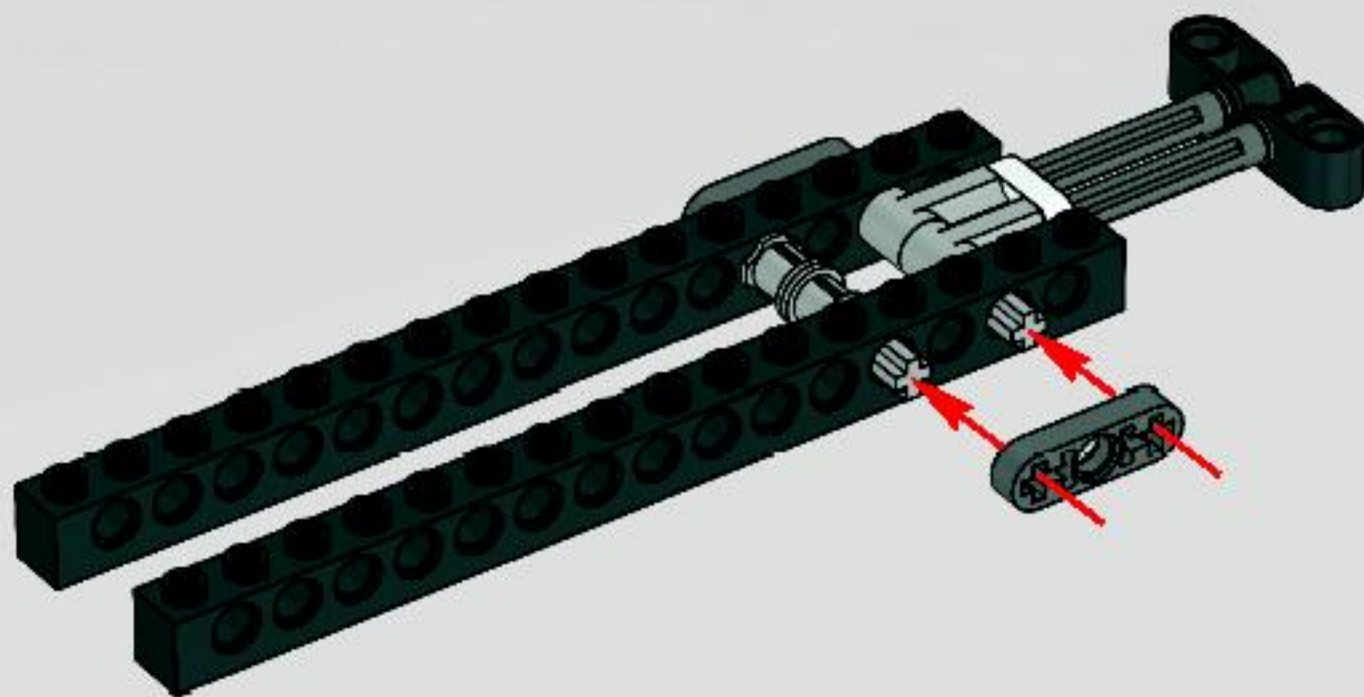

7

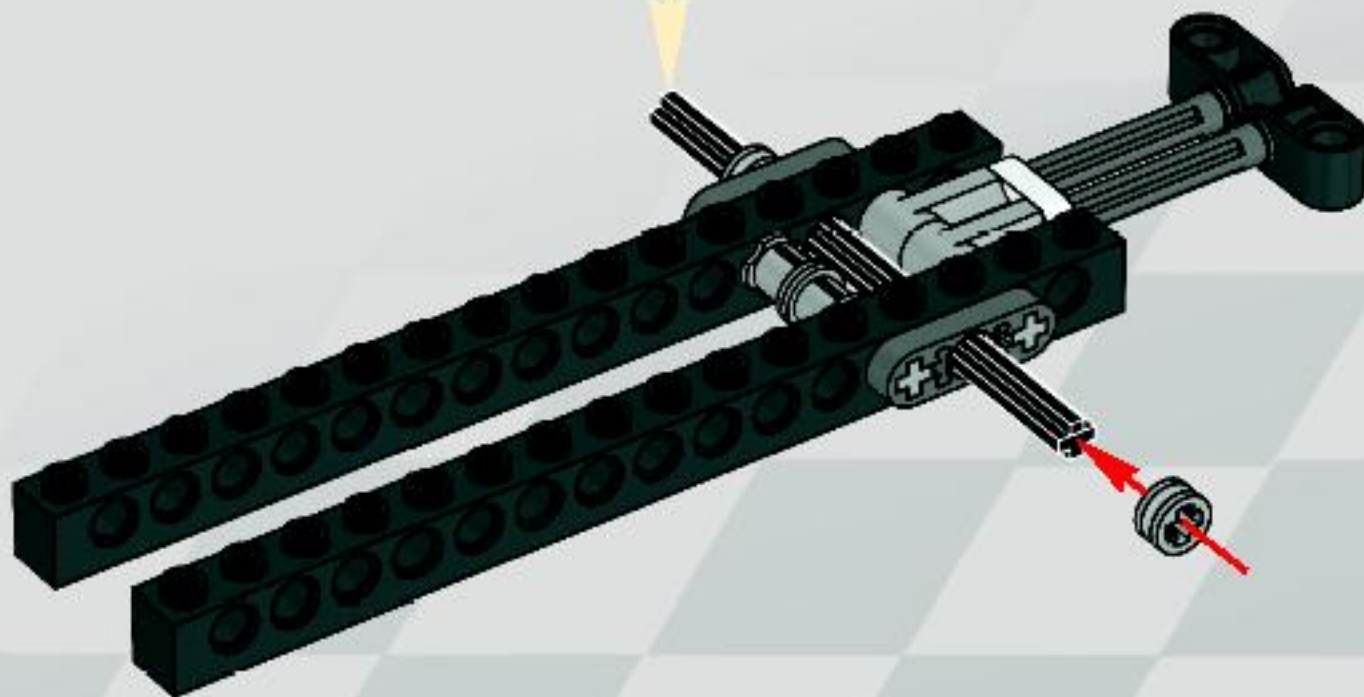

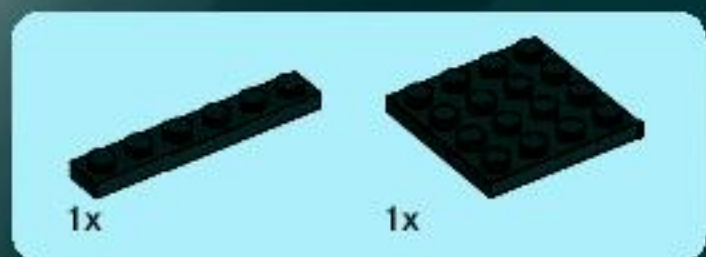

8

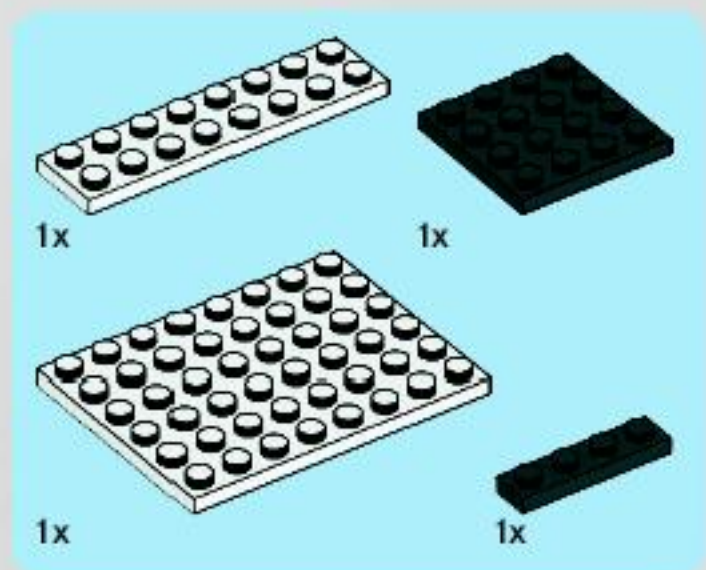
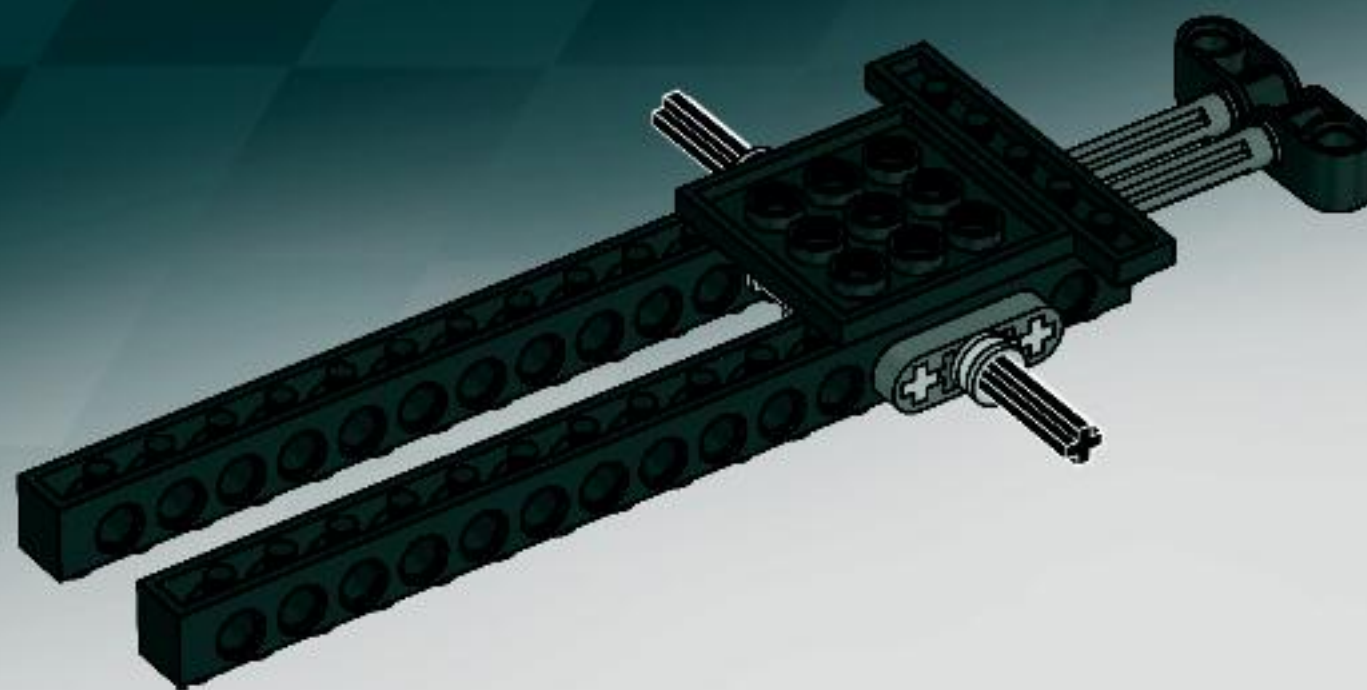

9

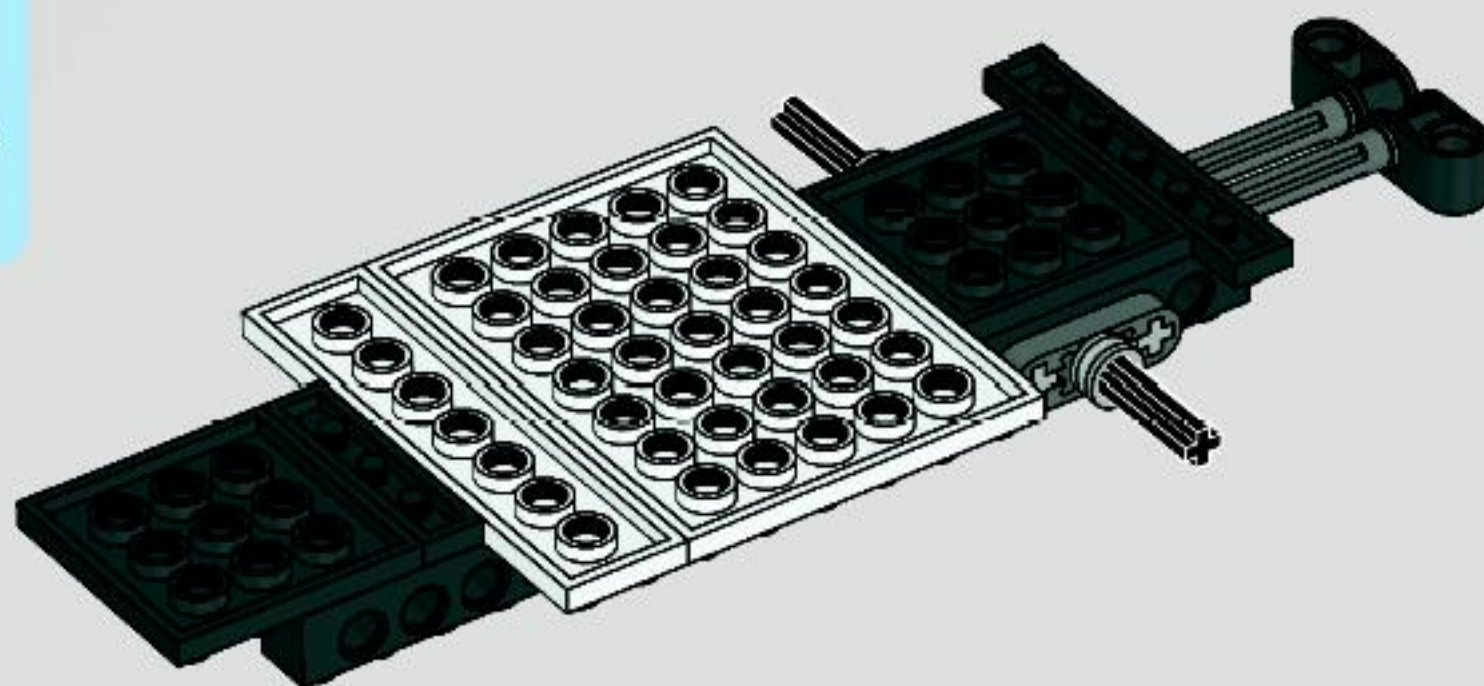



10

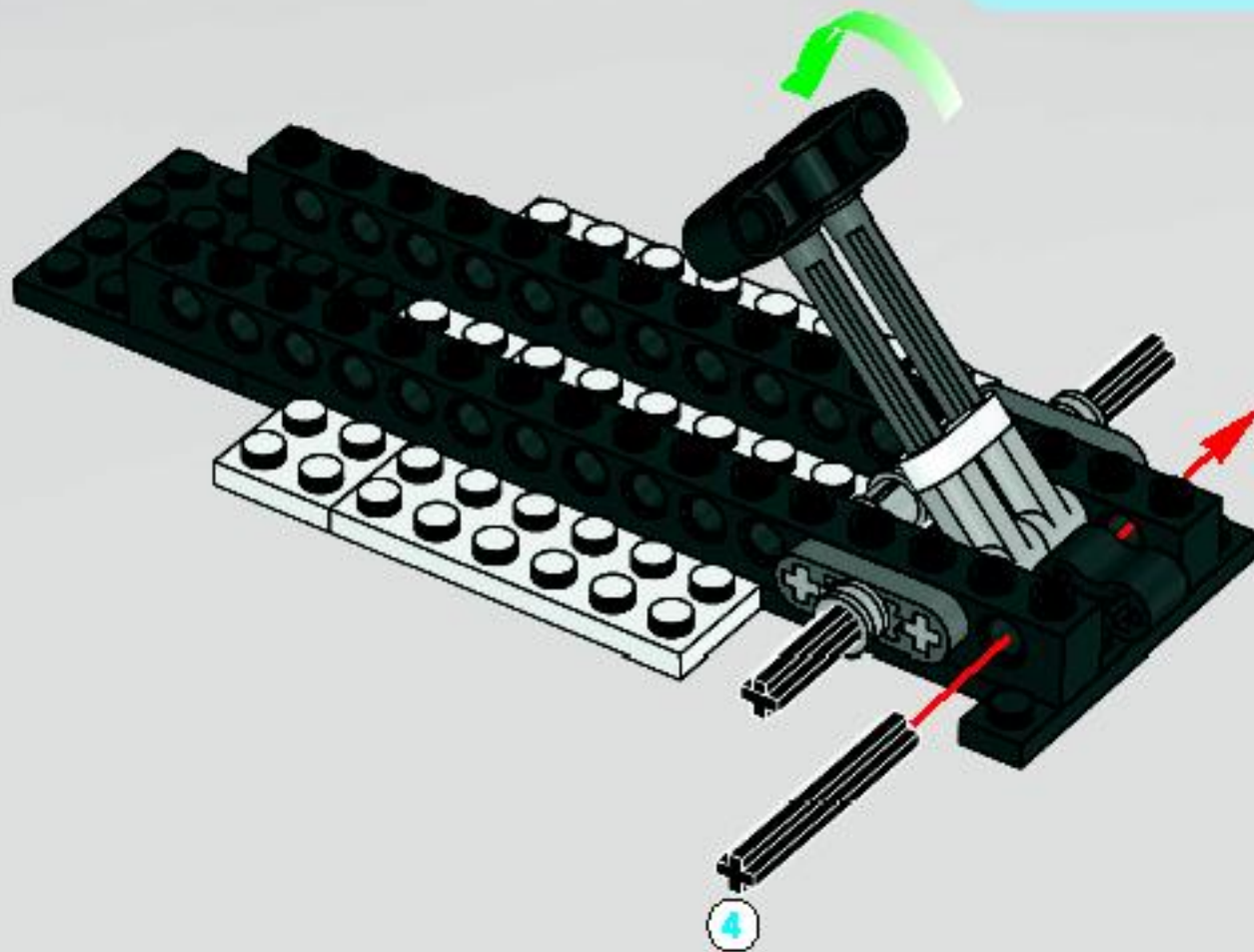

11

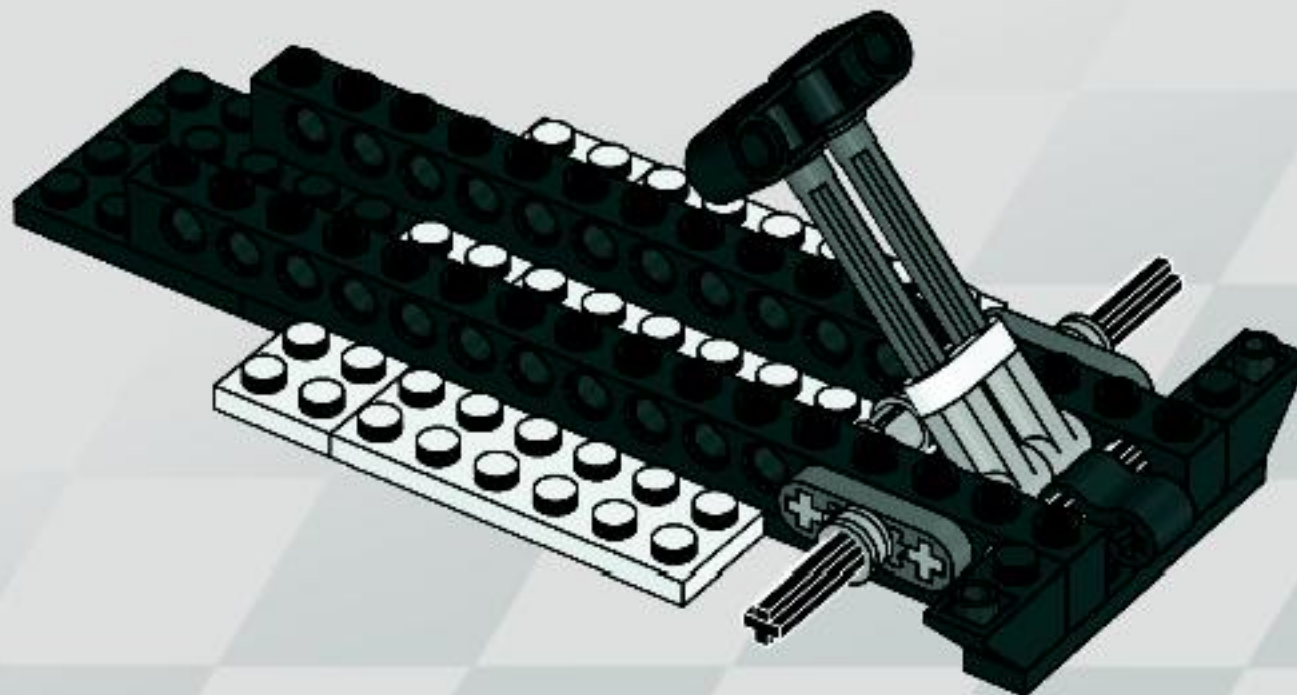



2x



1x

12

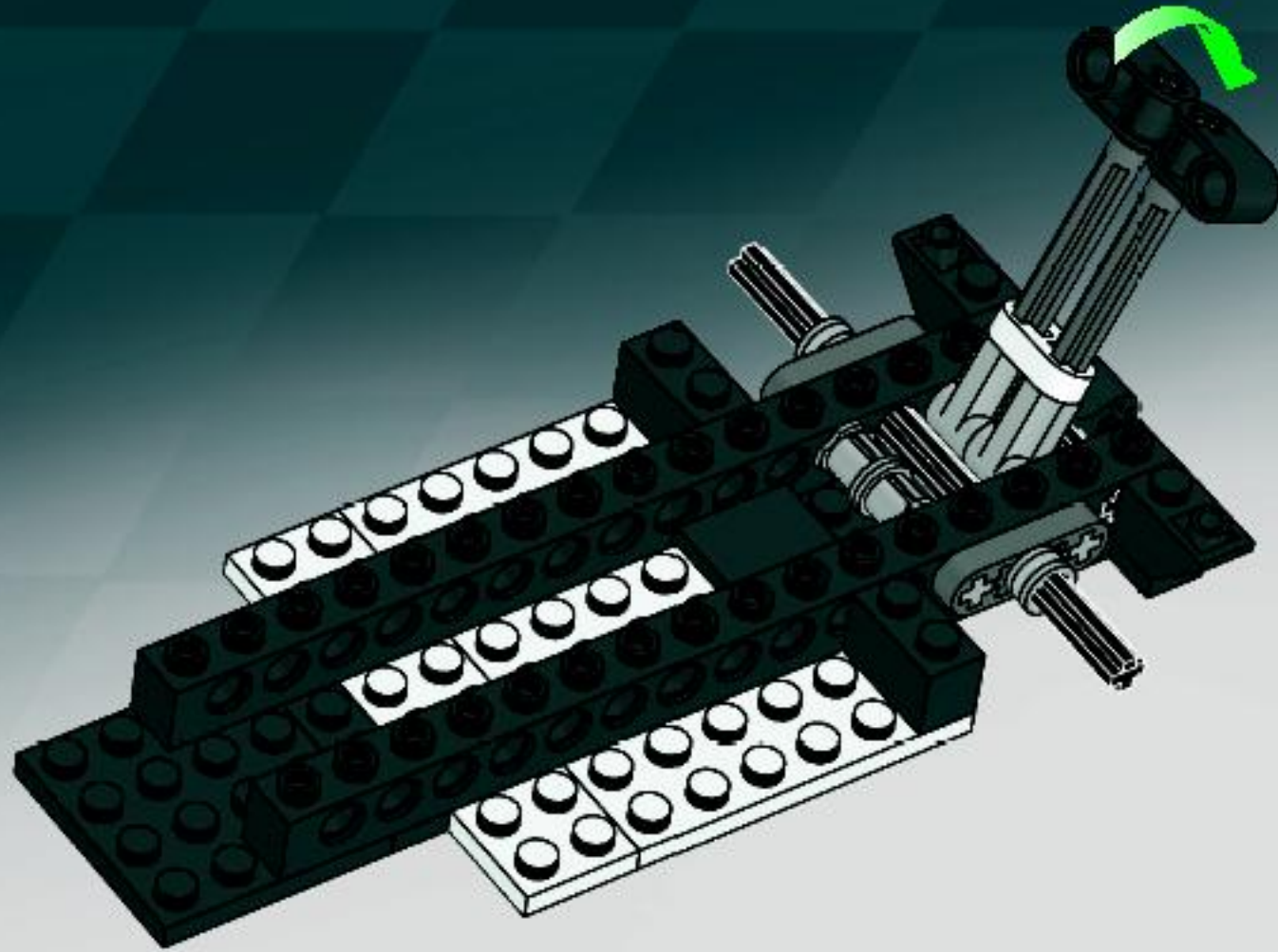

1x



2x



2x

13

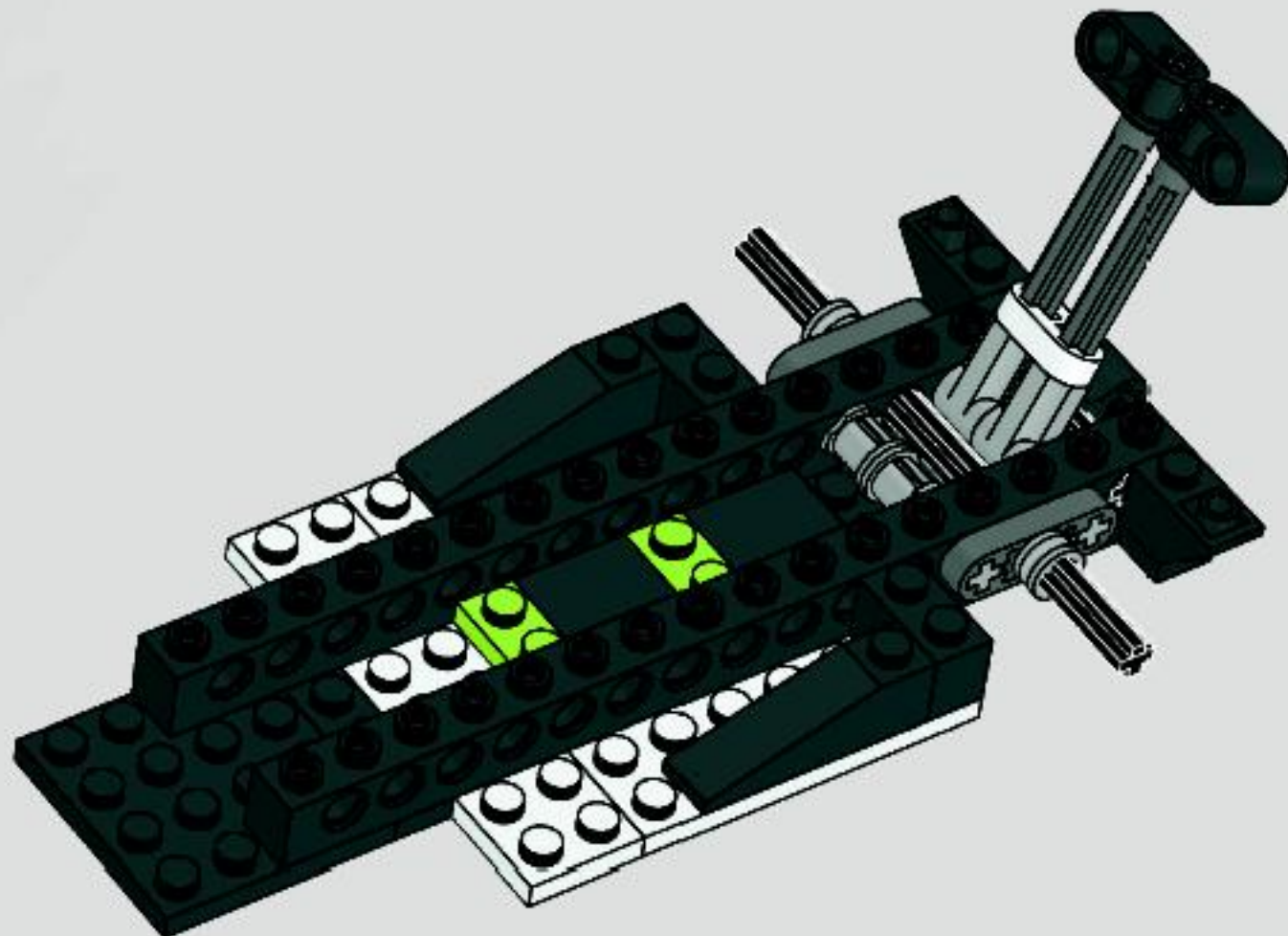



1x



1x

14

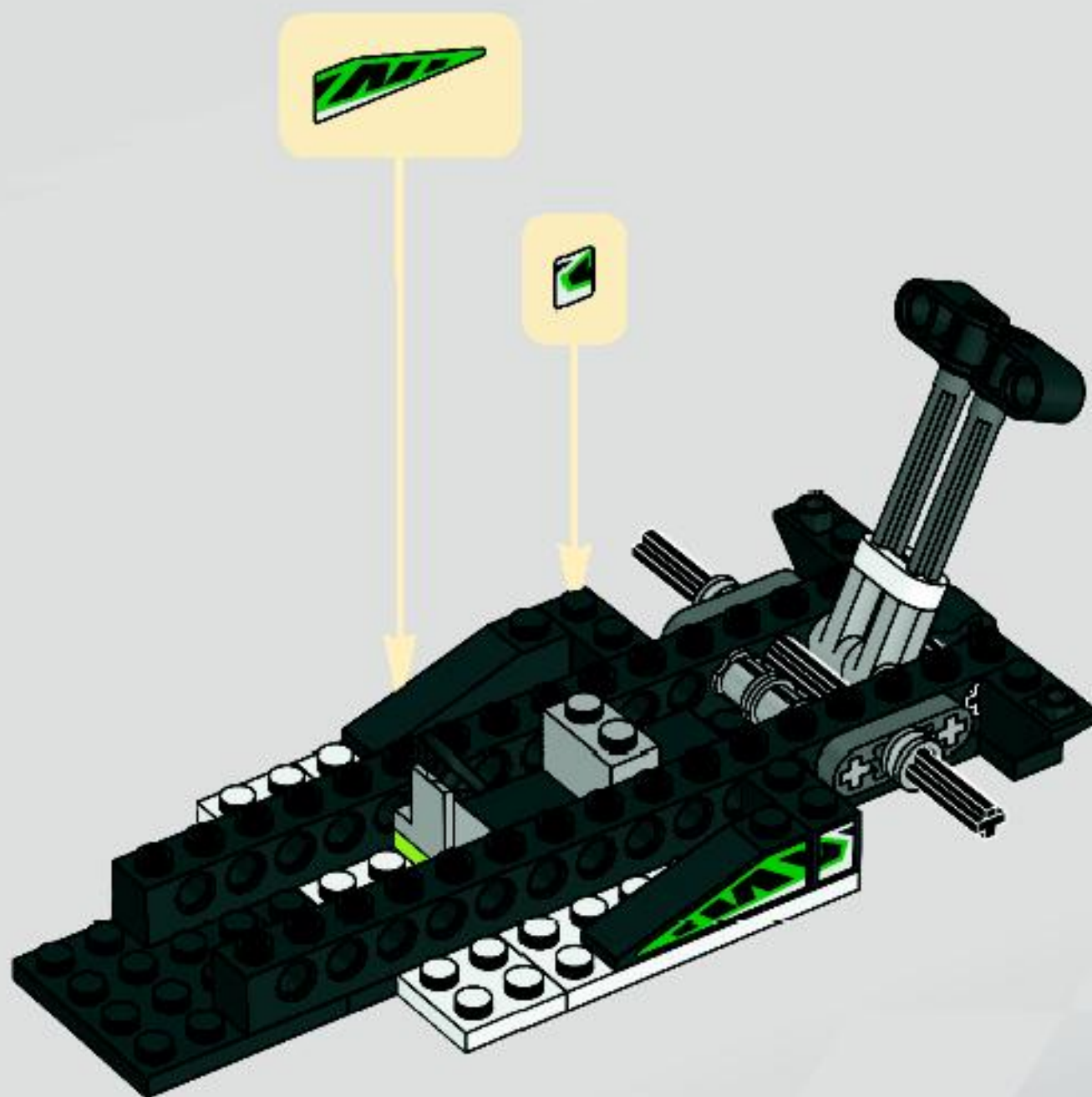



4x



1x



1x

15

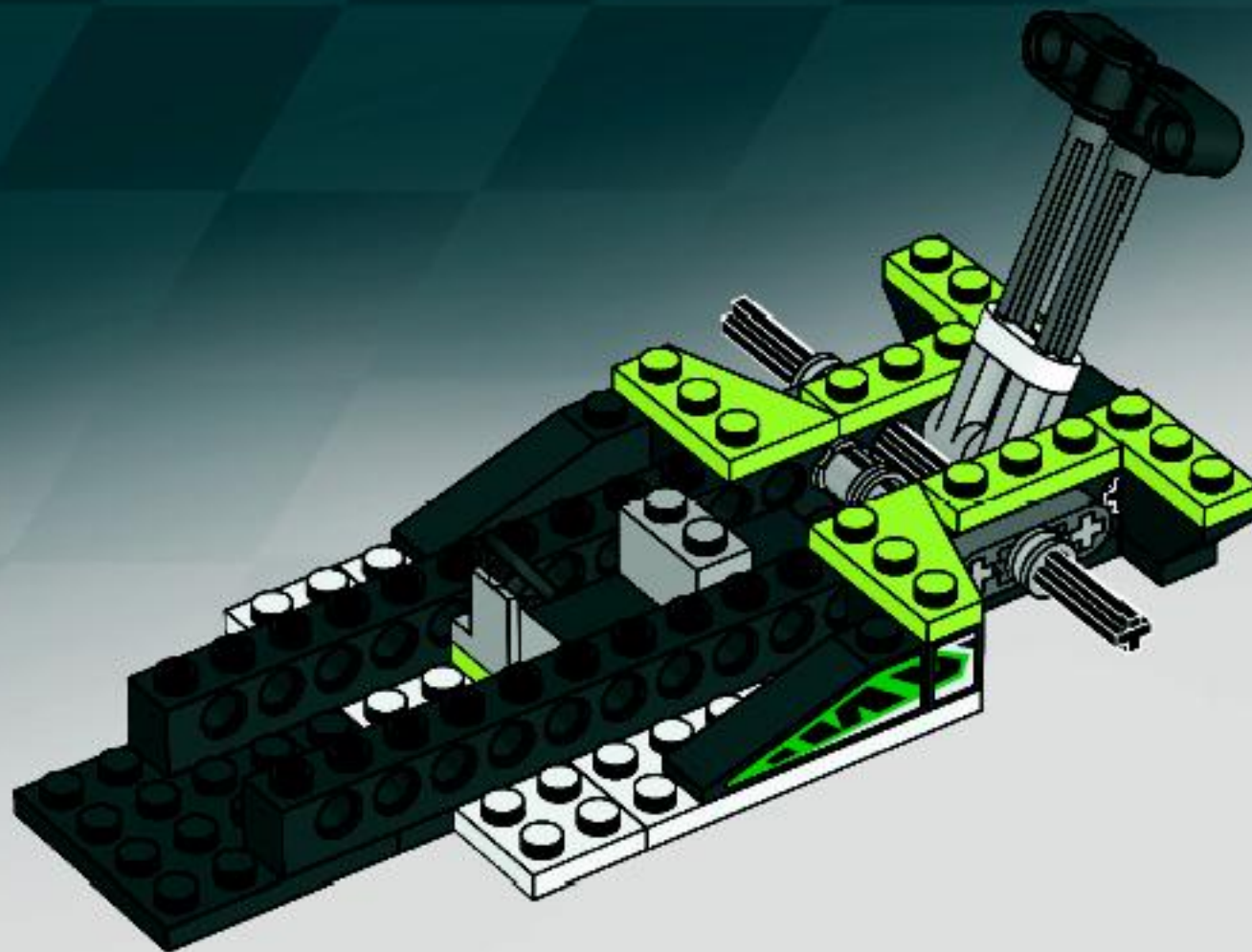

2x



2x

16

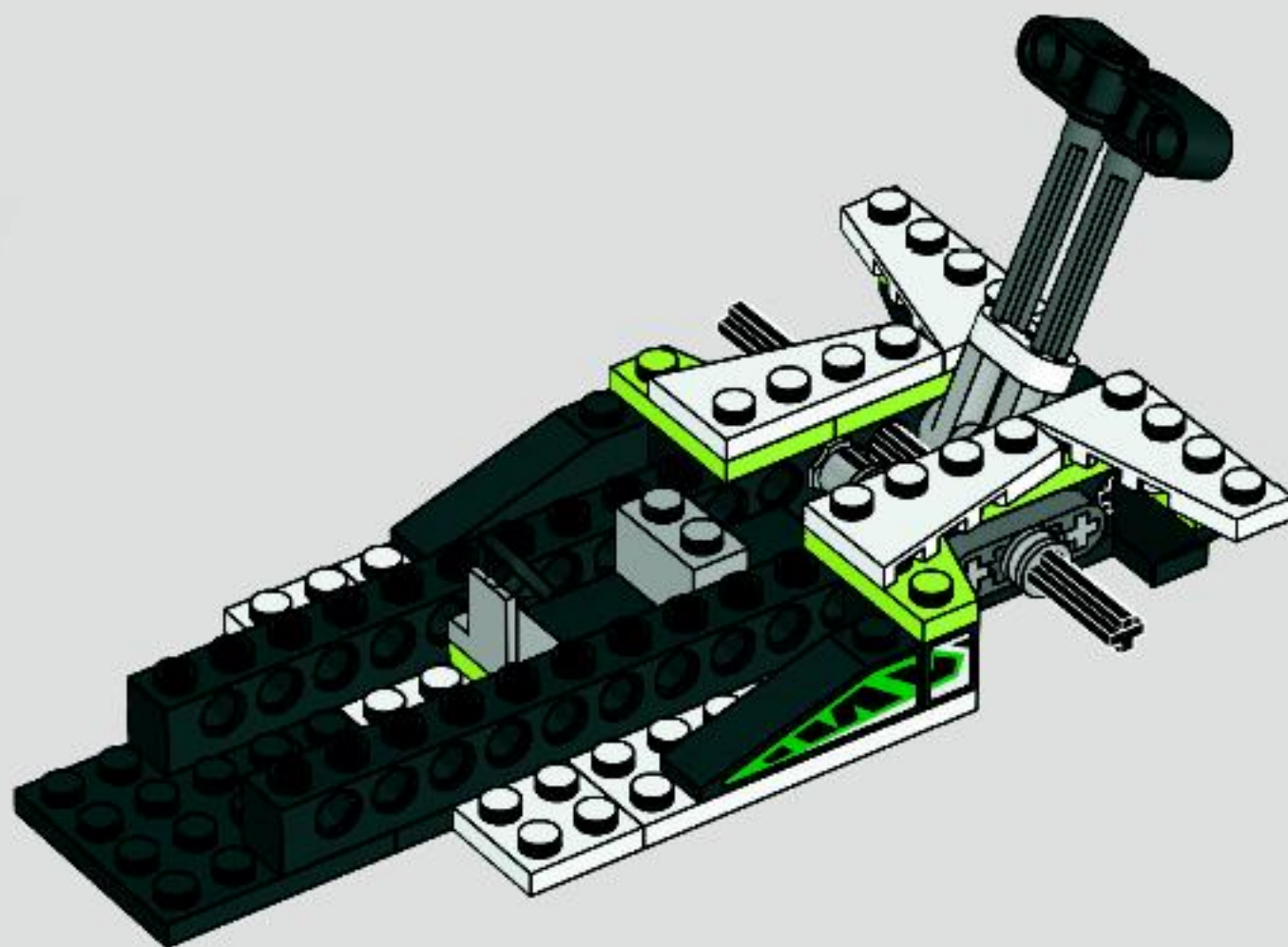

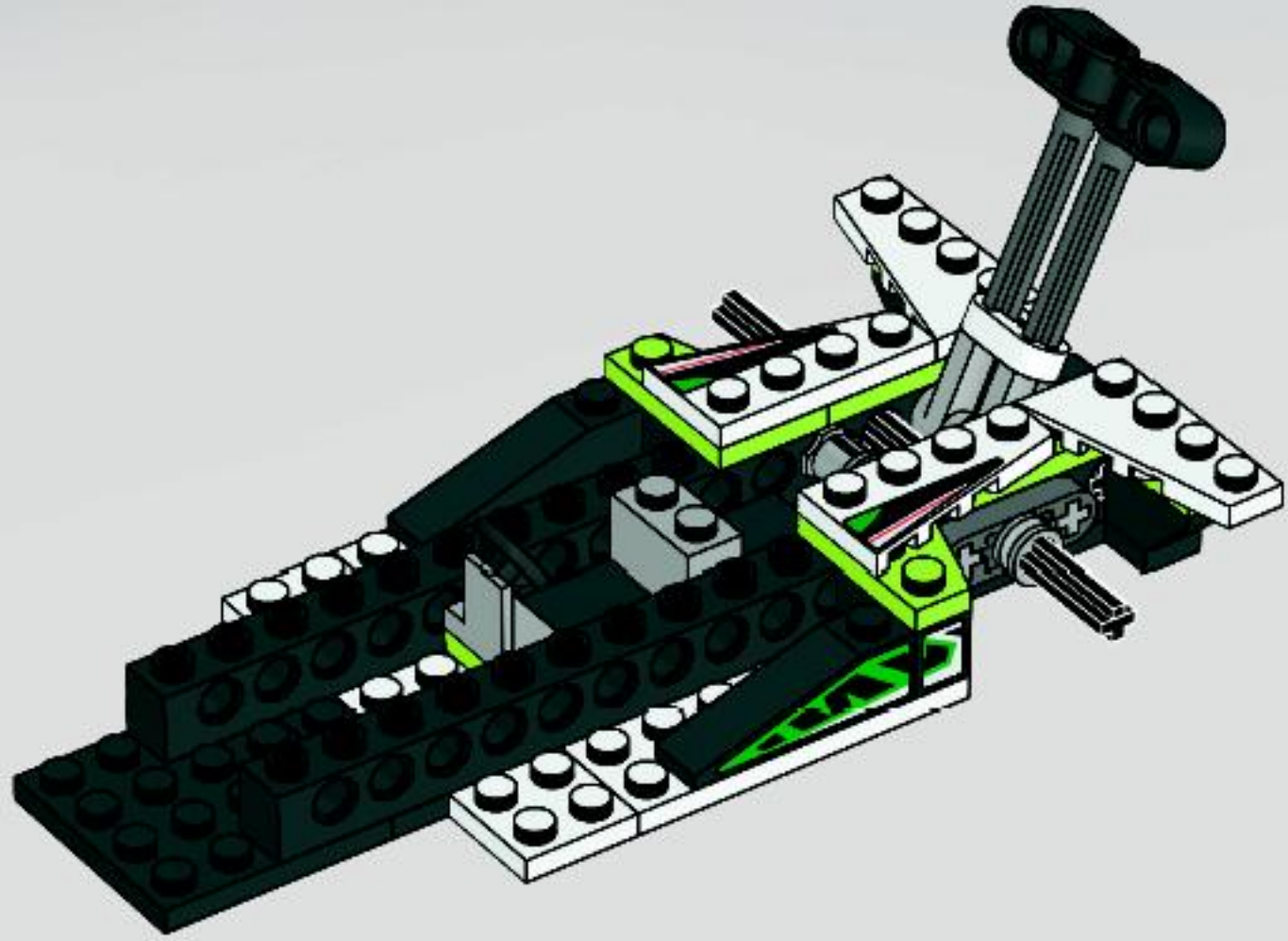

17

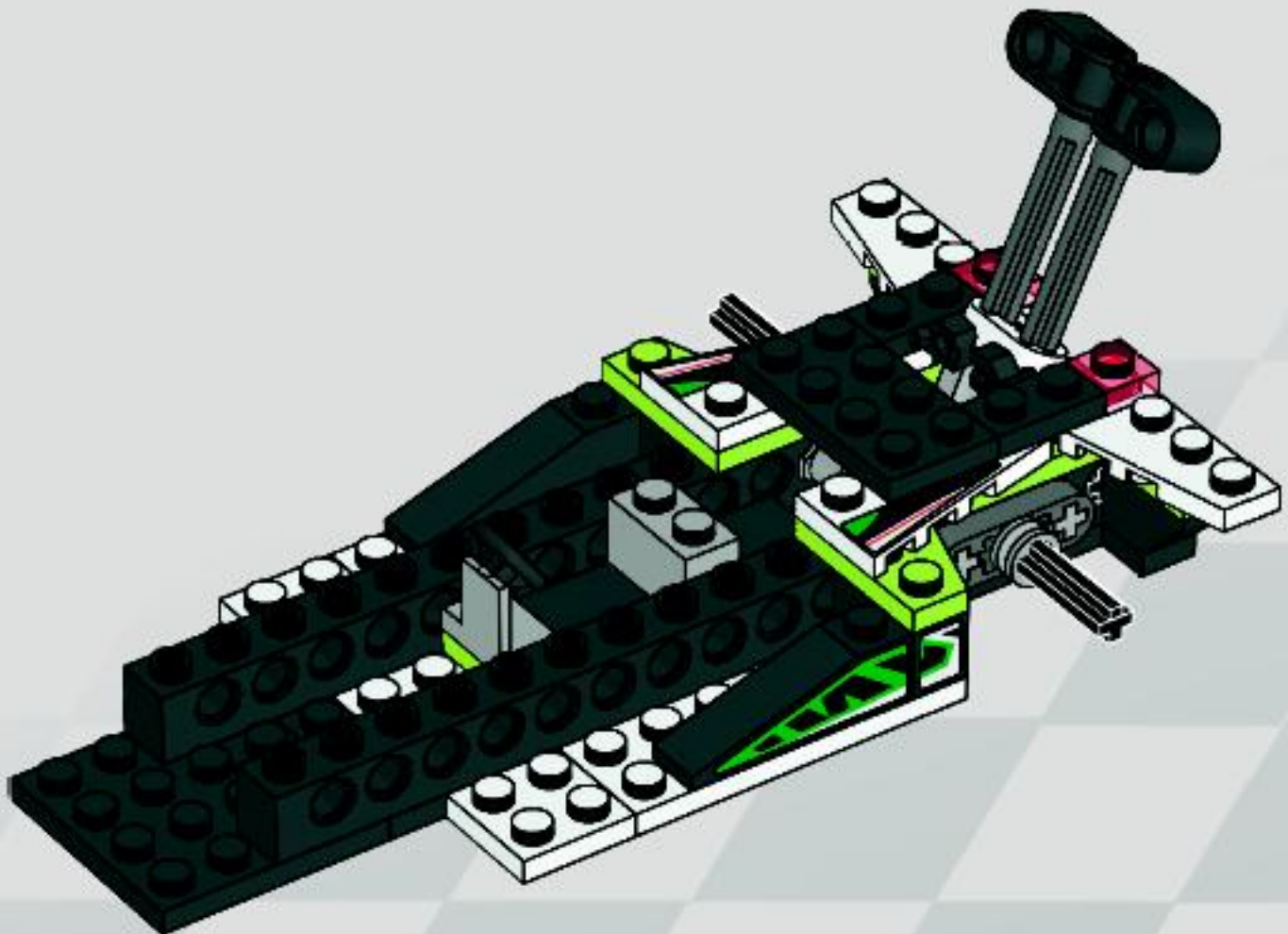

18



2x  3  2x  2x

 3  1:1

19

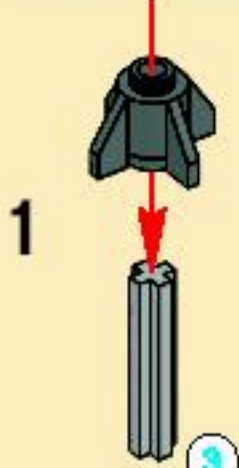
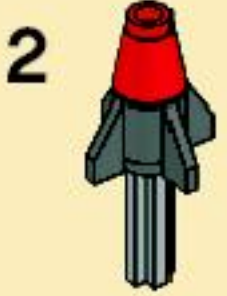
1  2  2x

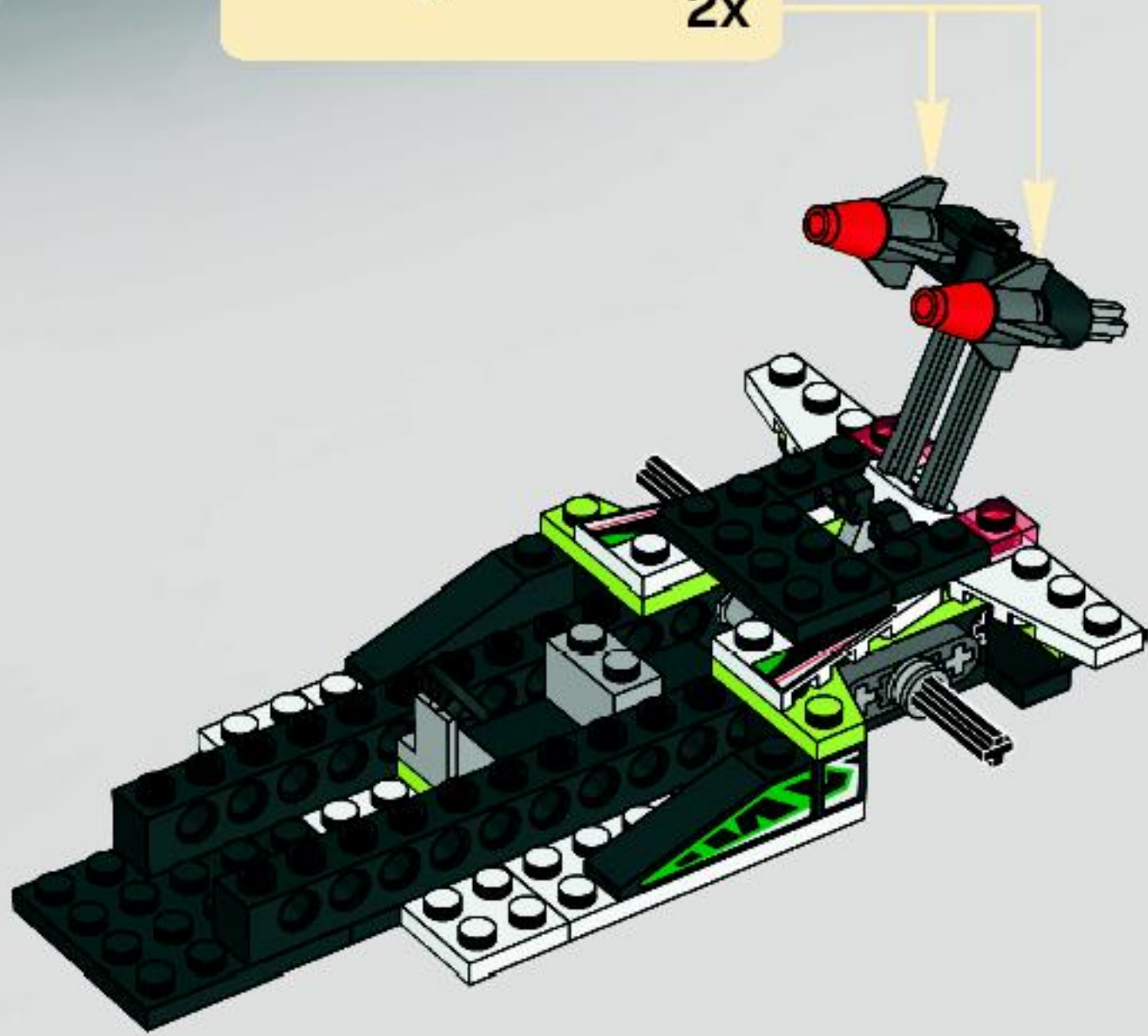



20

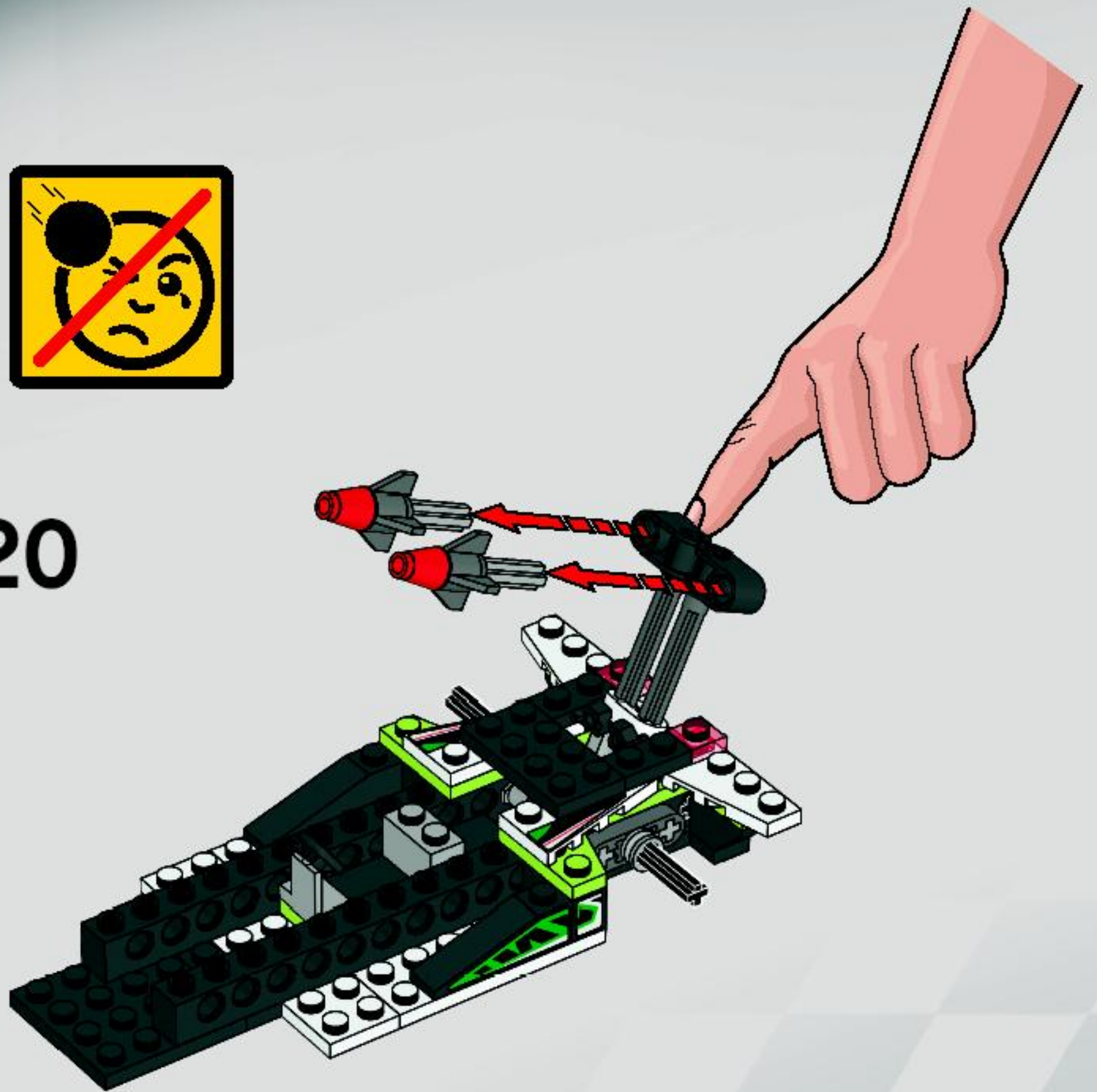

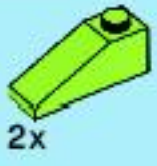

2x



1x

21

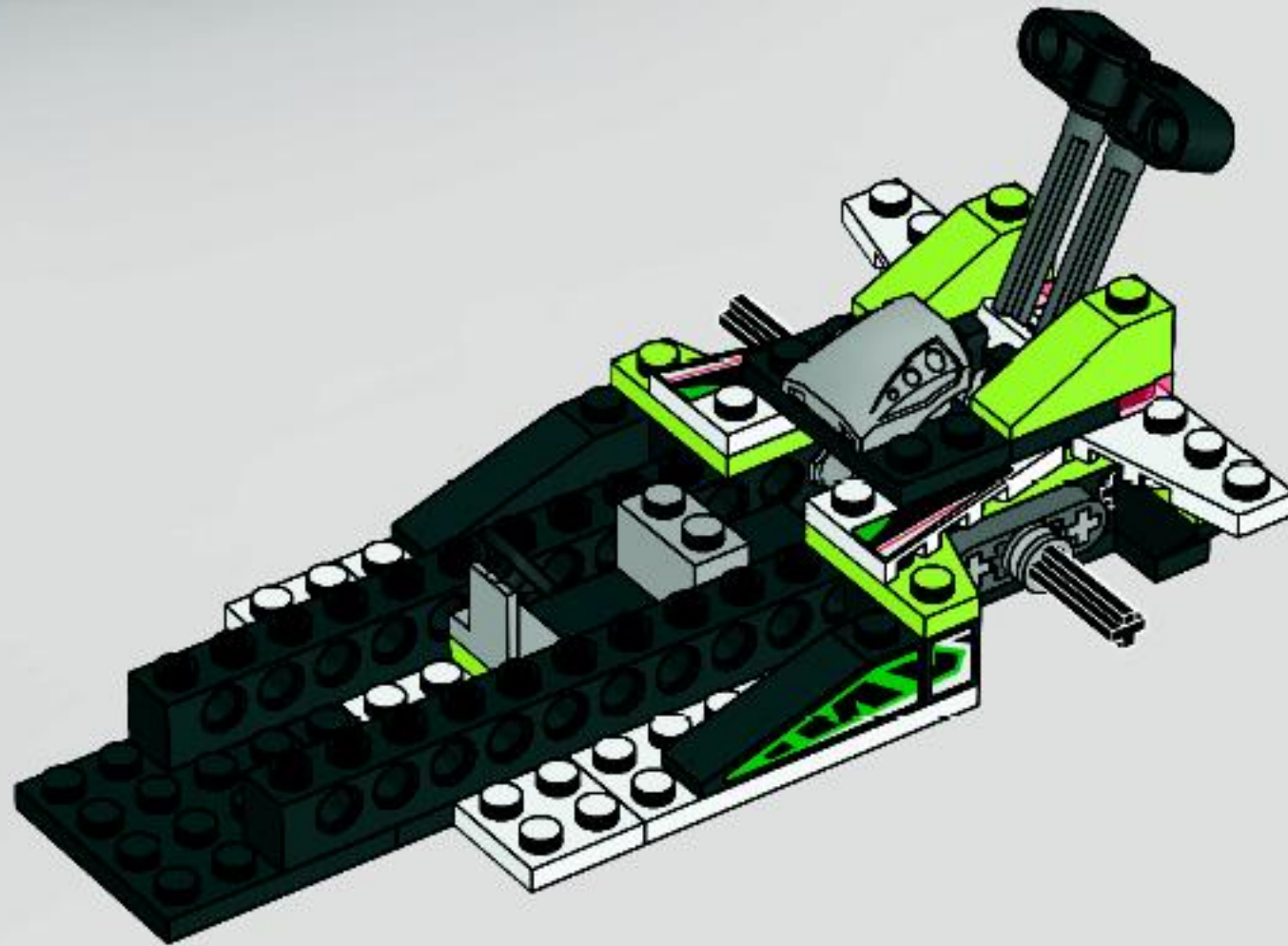



2x



2x

22



2x

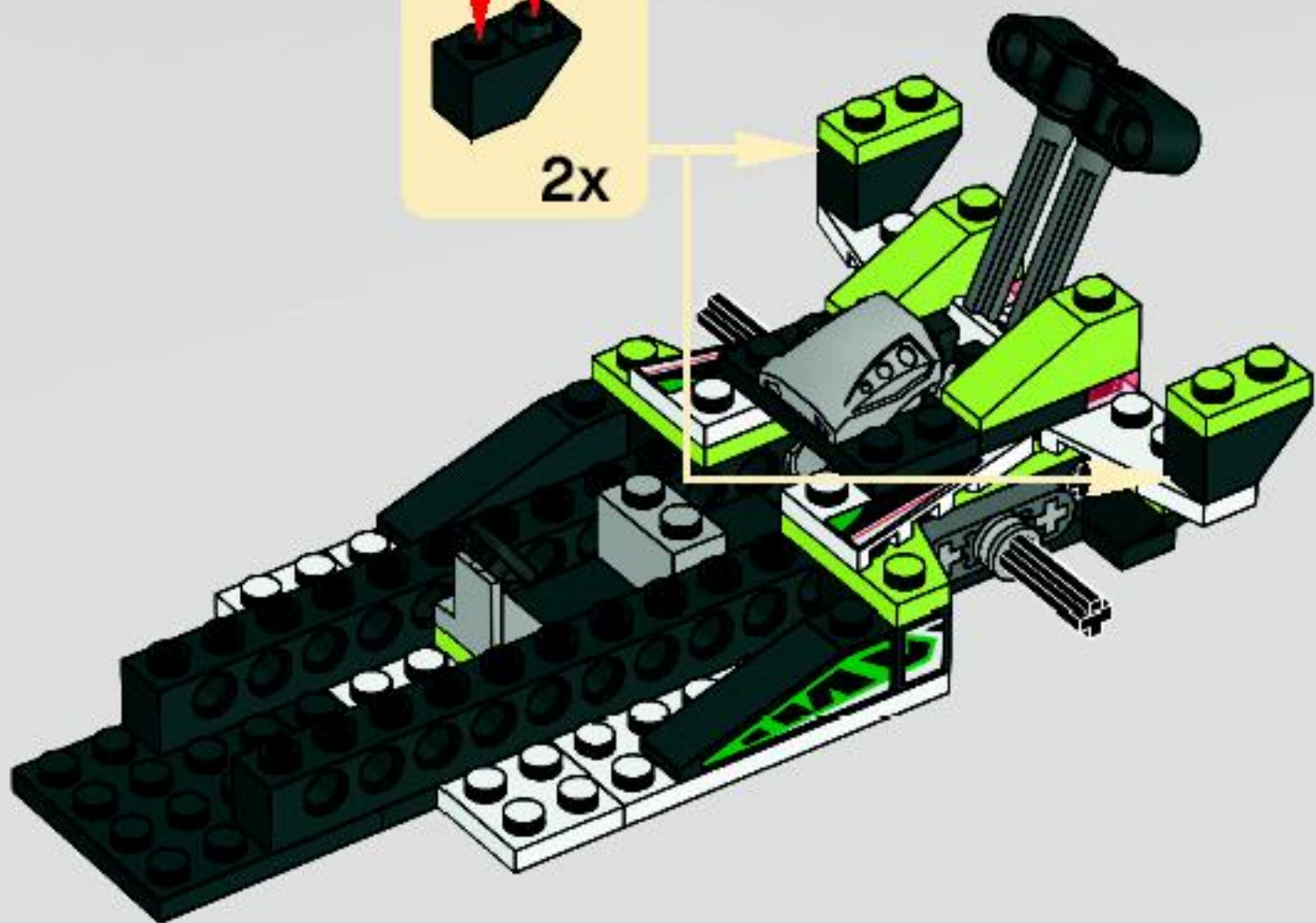

1x



1x

23

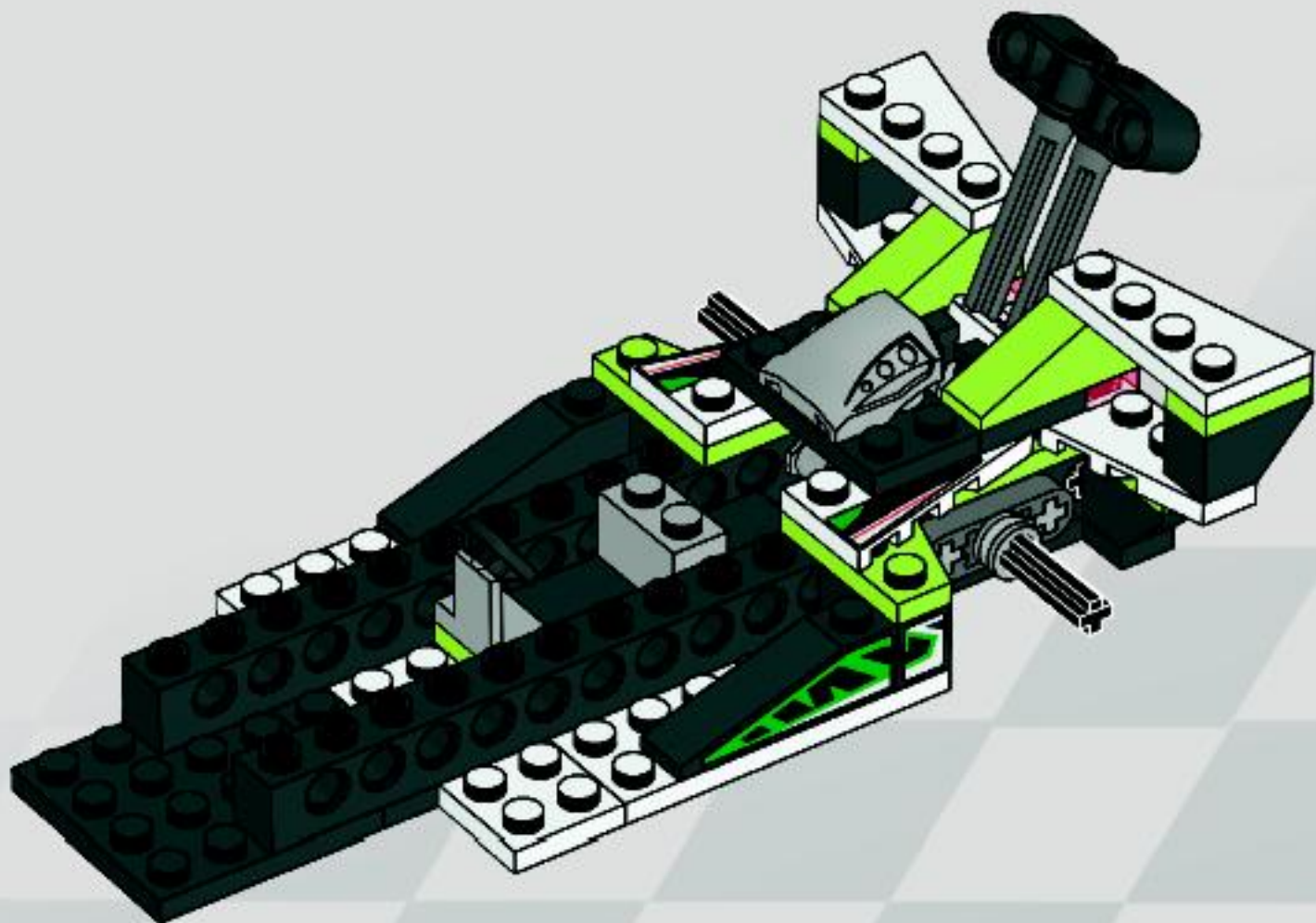



24

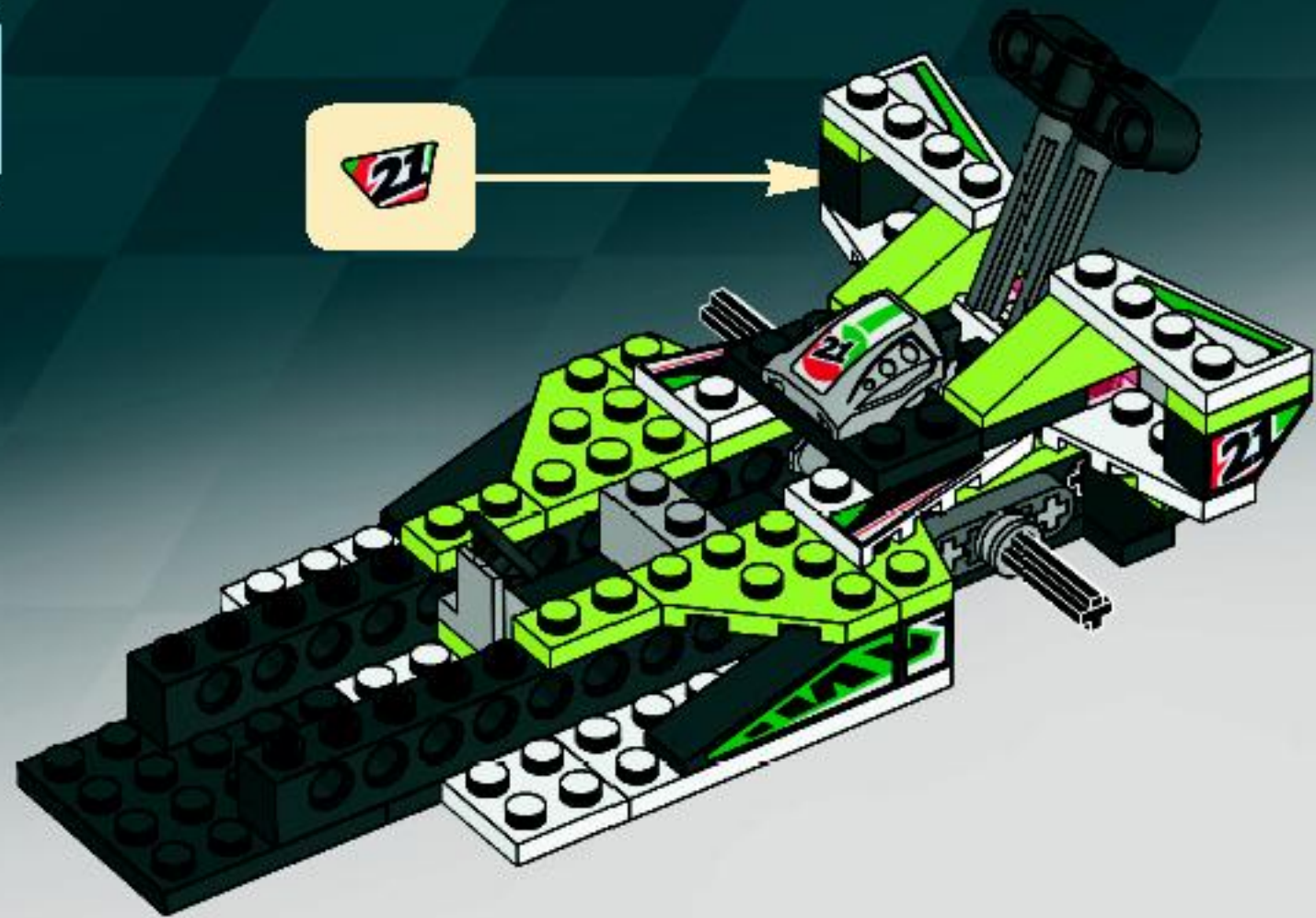

25

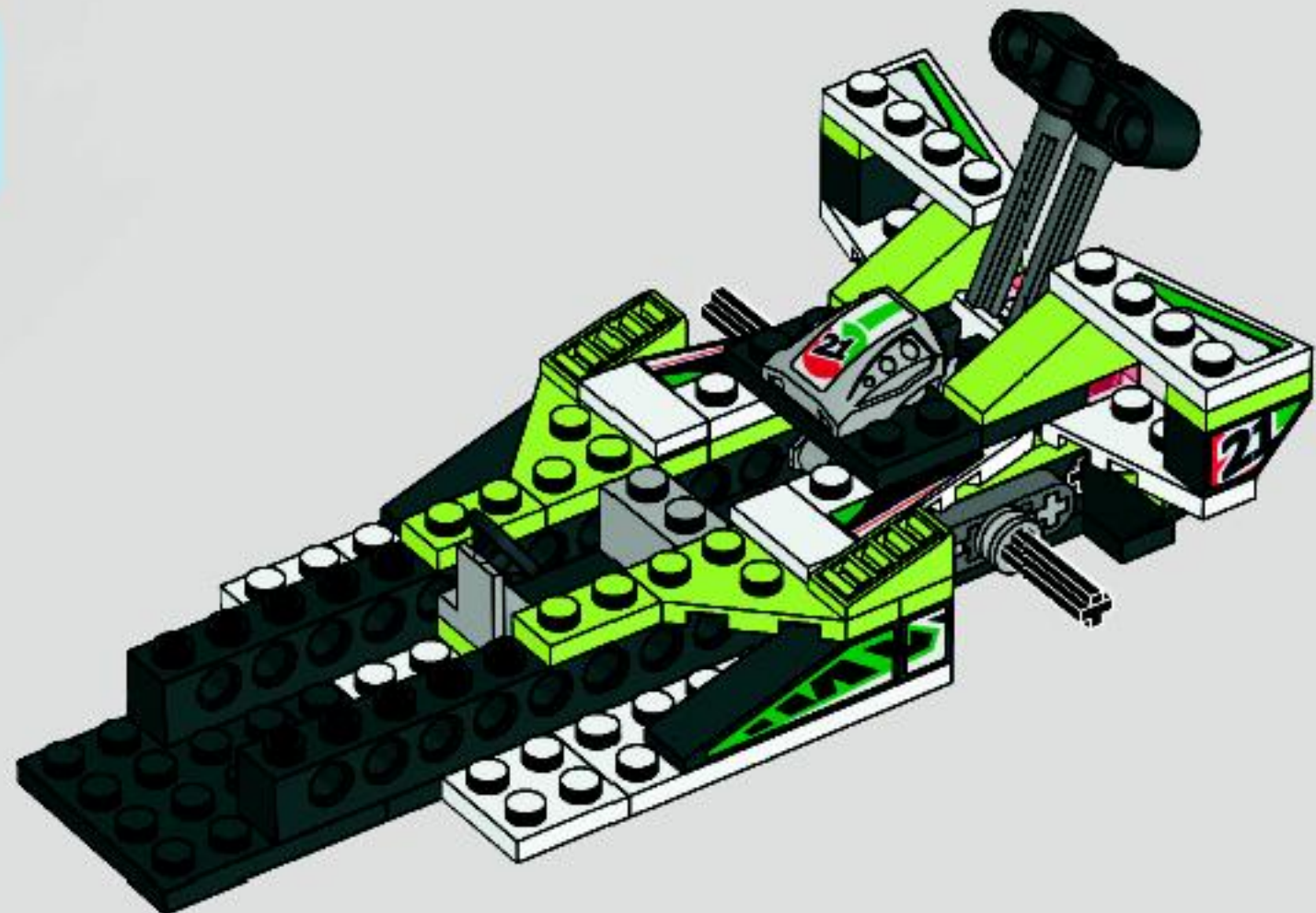



2x



1x

26

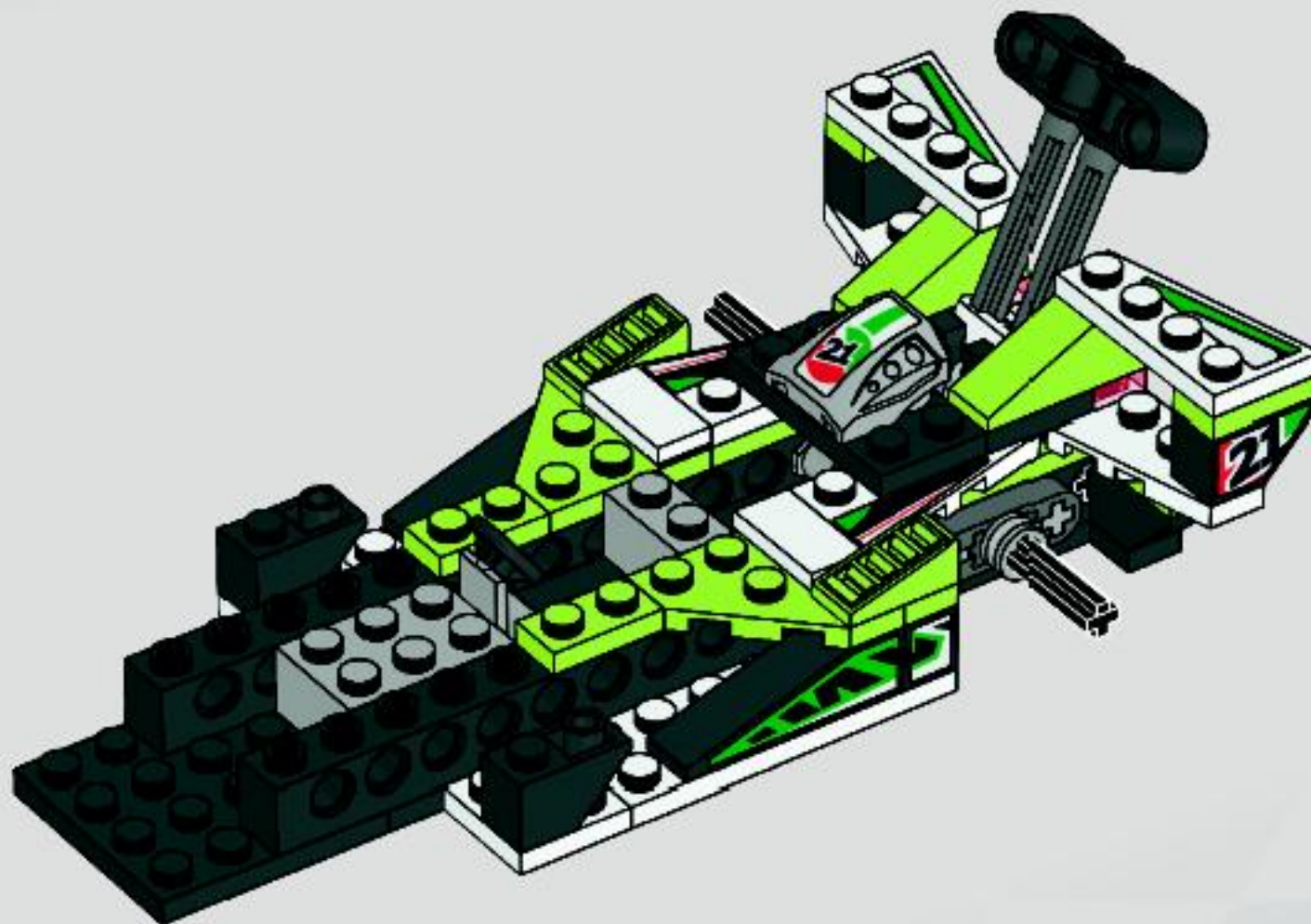

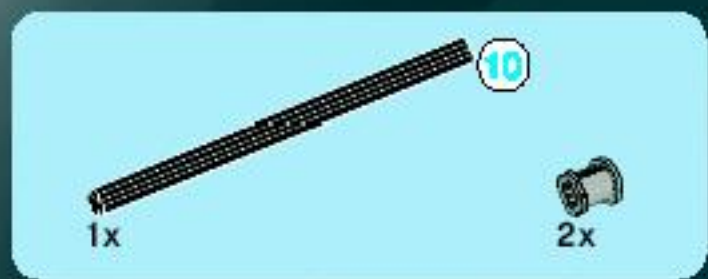

27

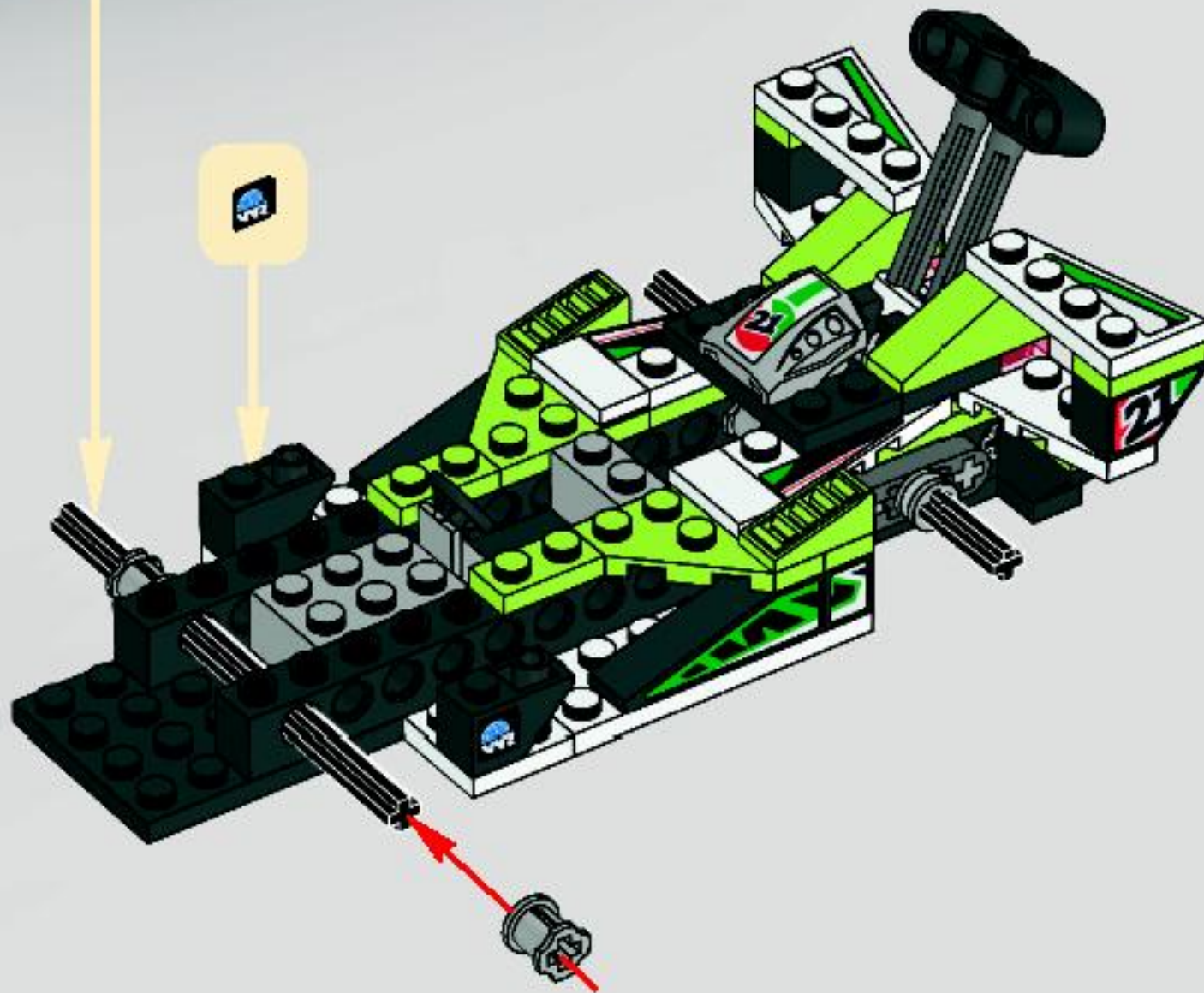

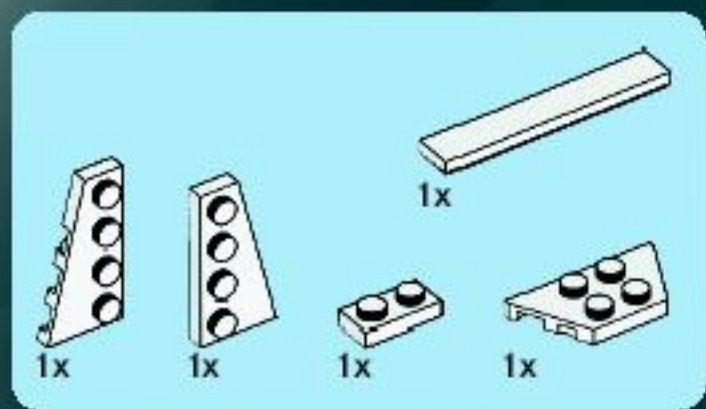

29

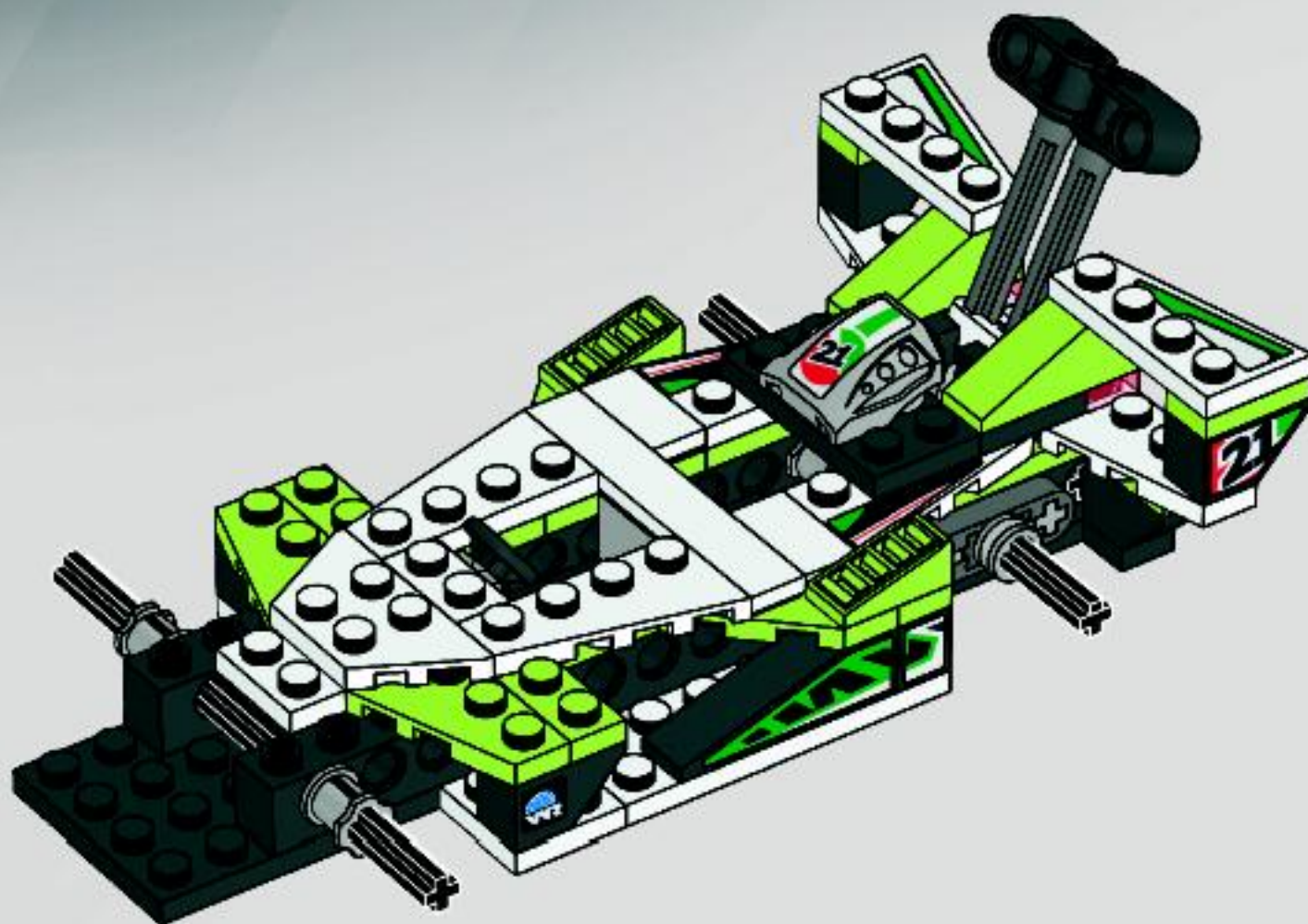



1x



2x

30

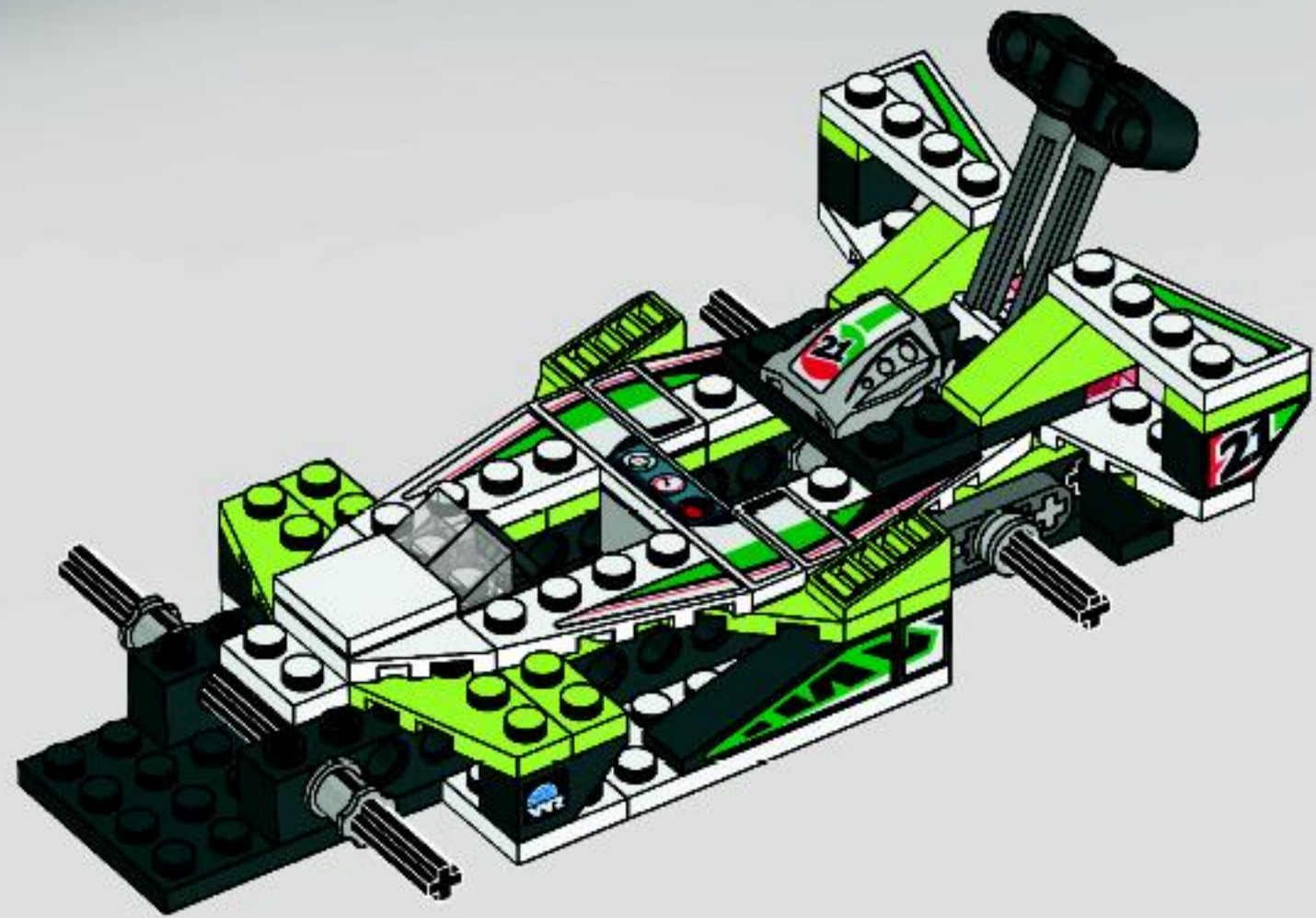

1x



1x



1x

31

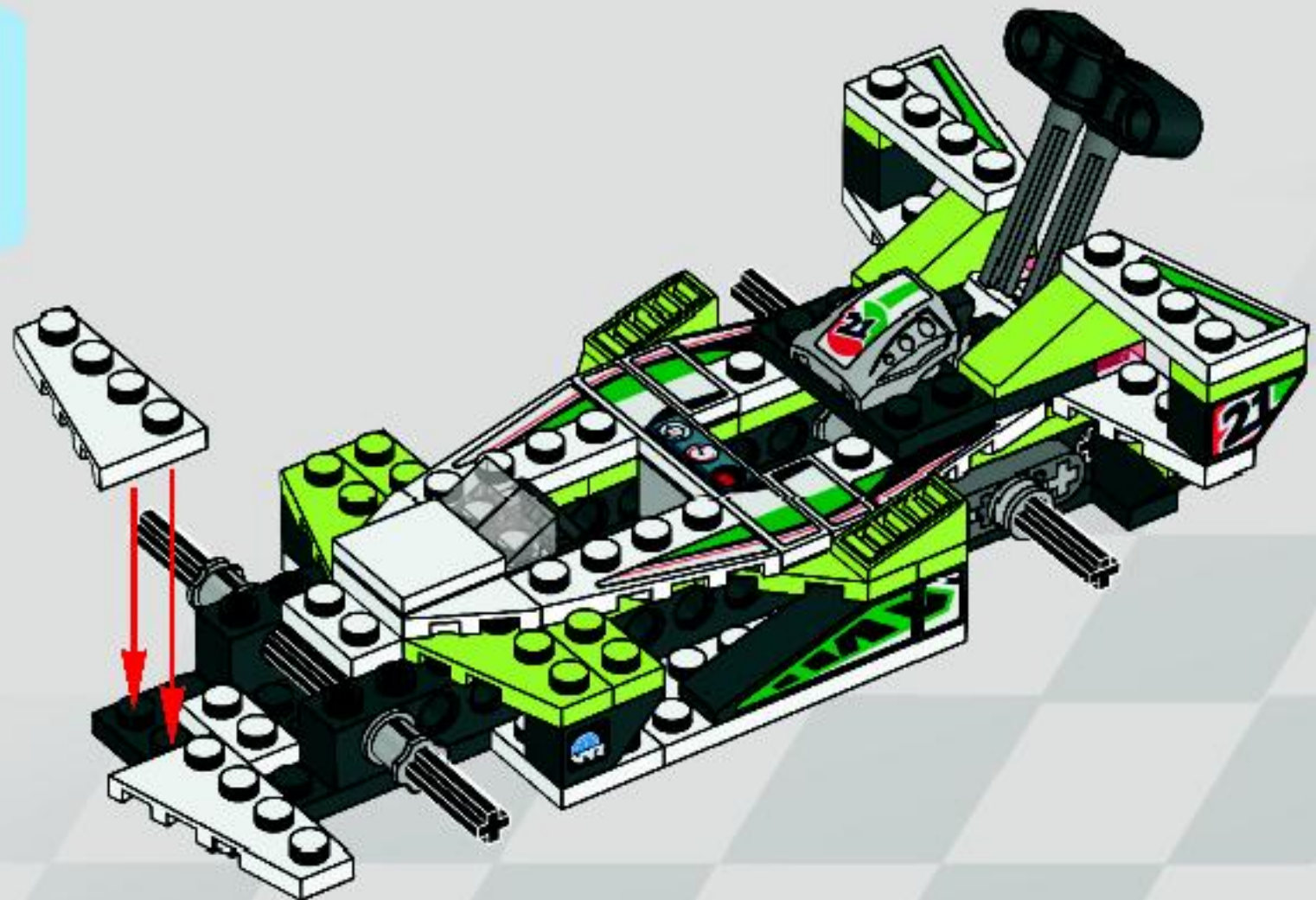



1x

32

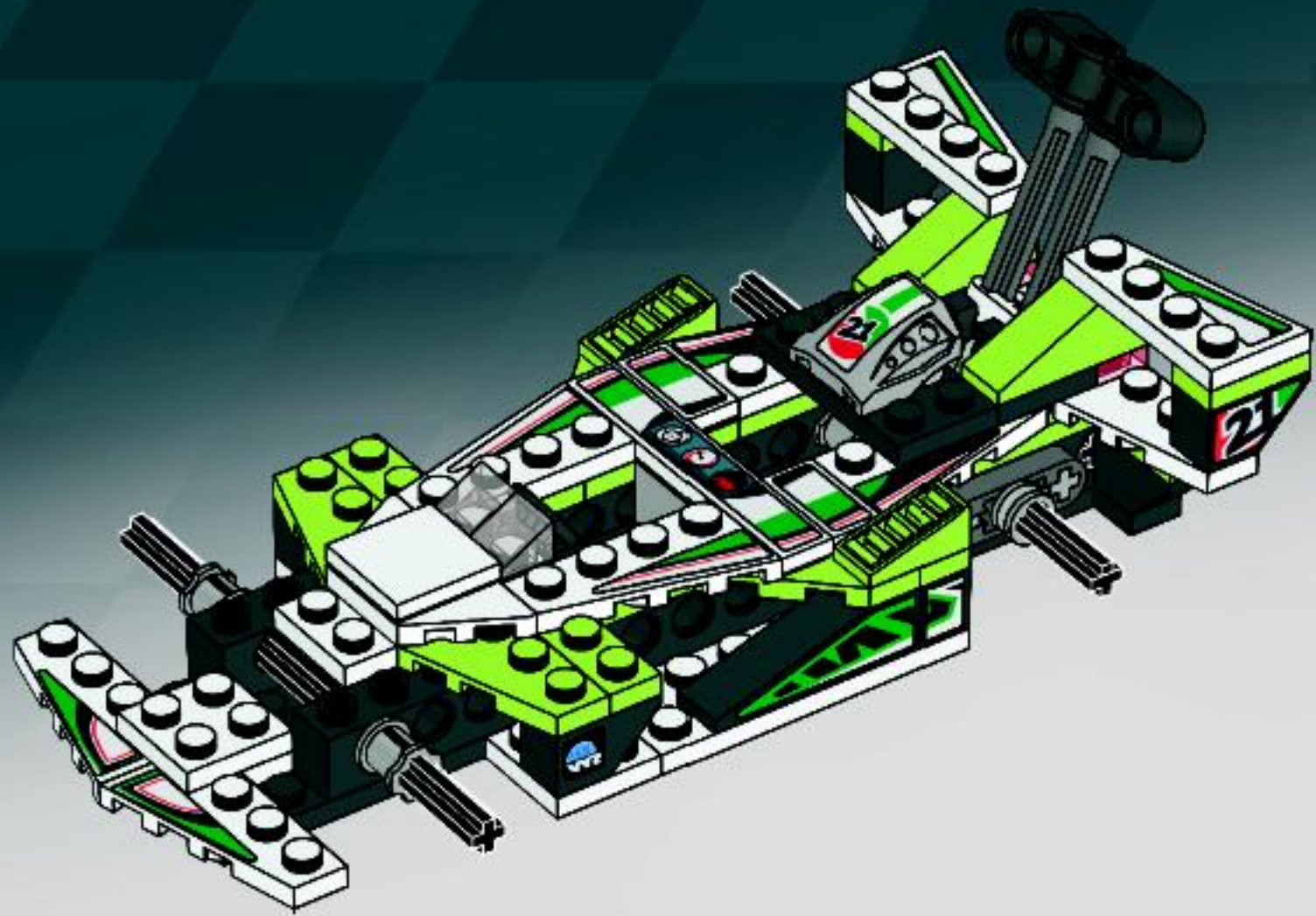

2x

33

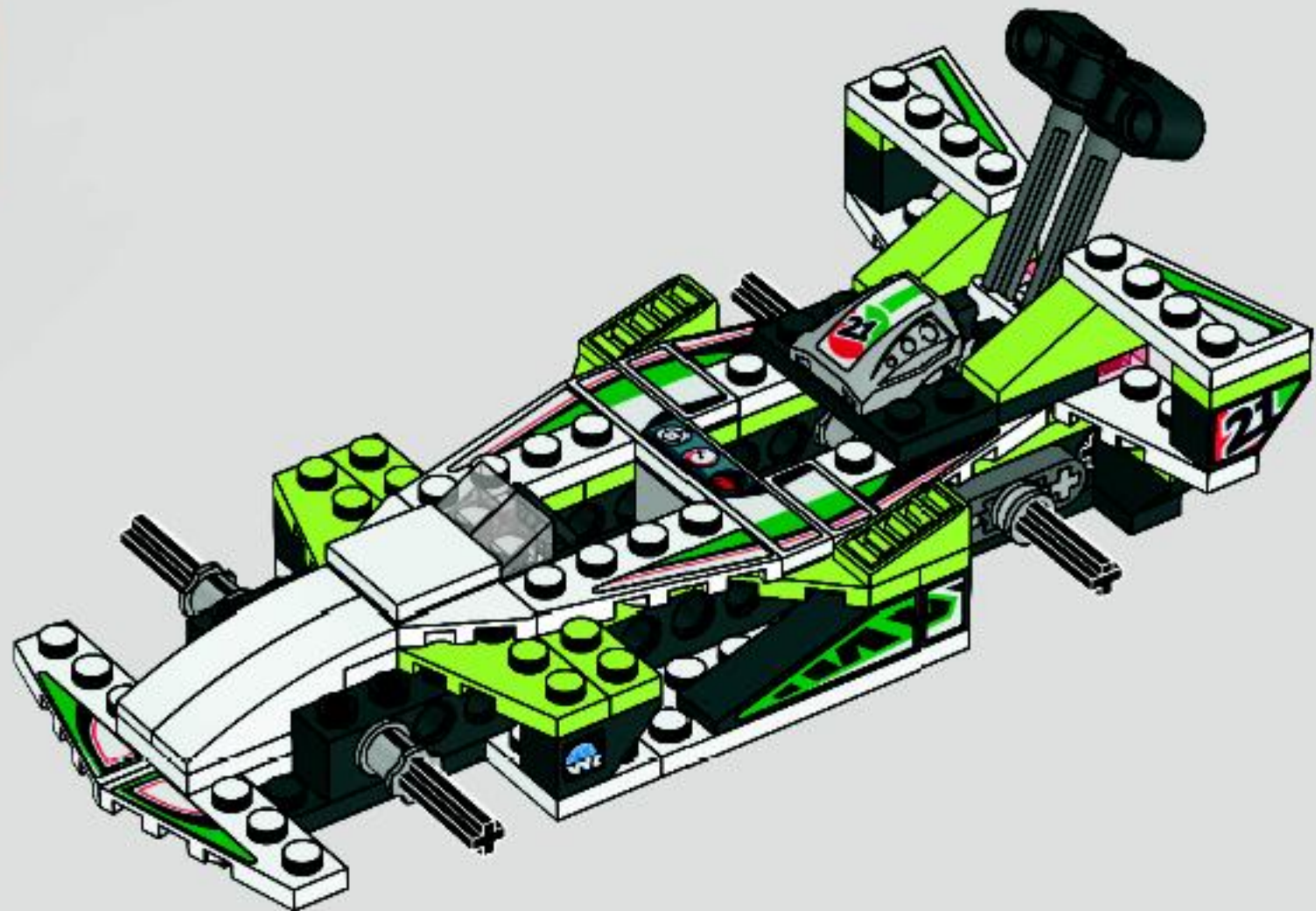



4x



4x

34

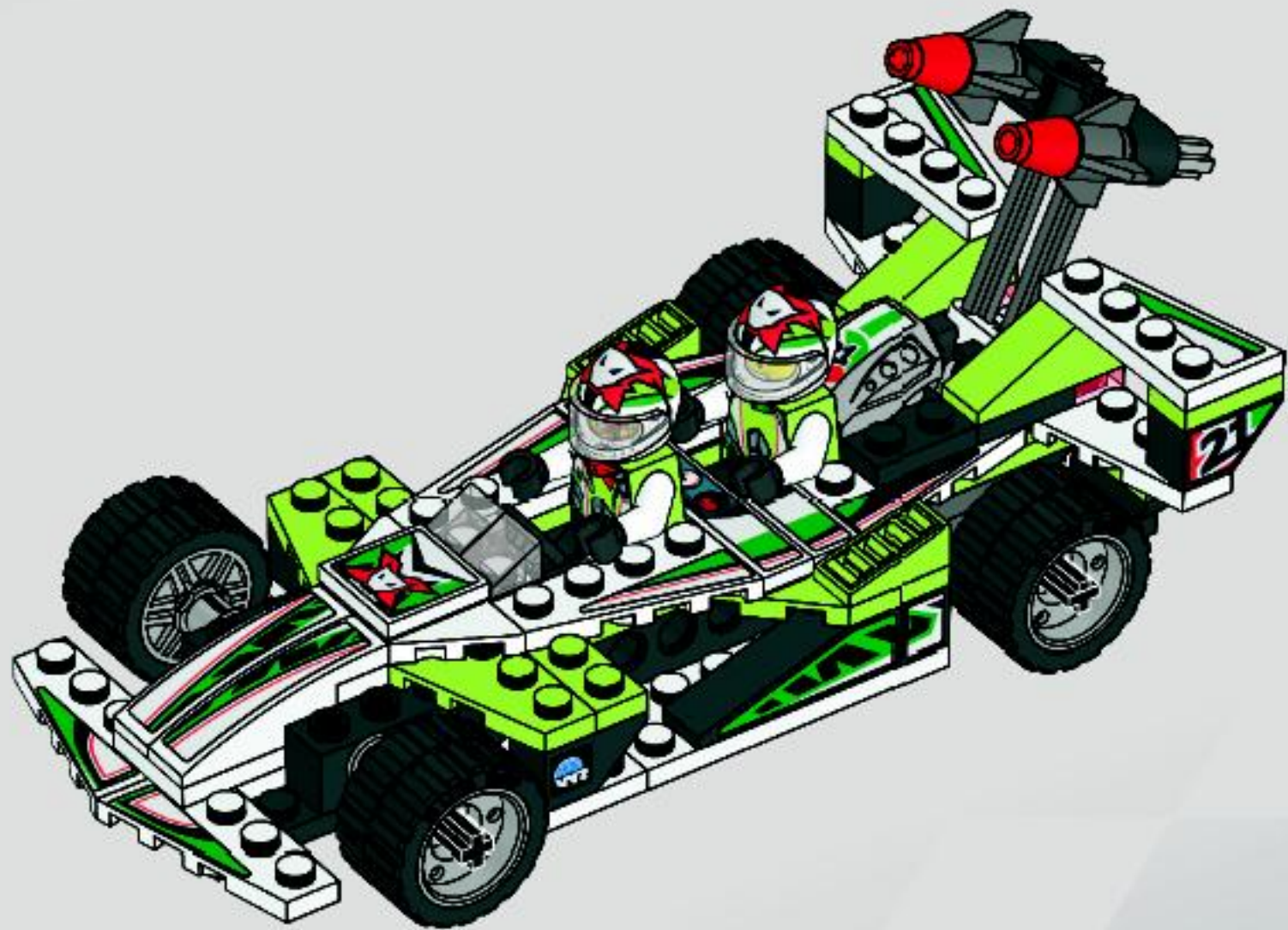



1x

1



2x



1x

2



1x

3

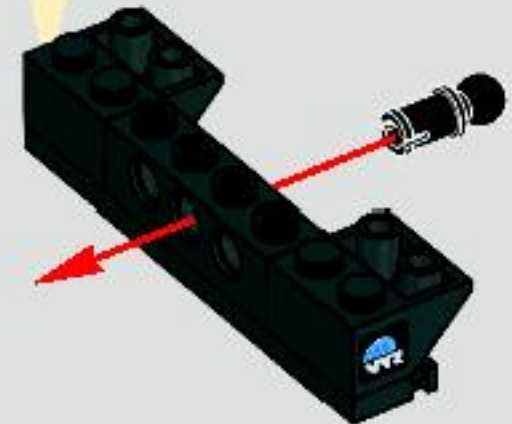



2x

4



2x

6

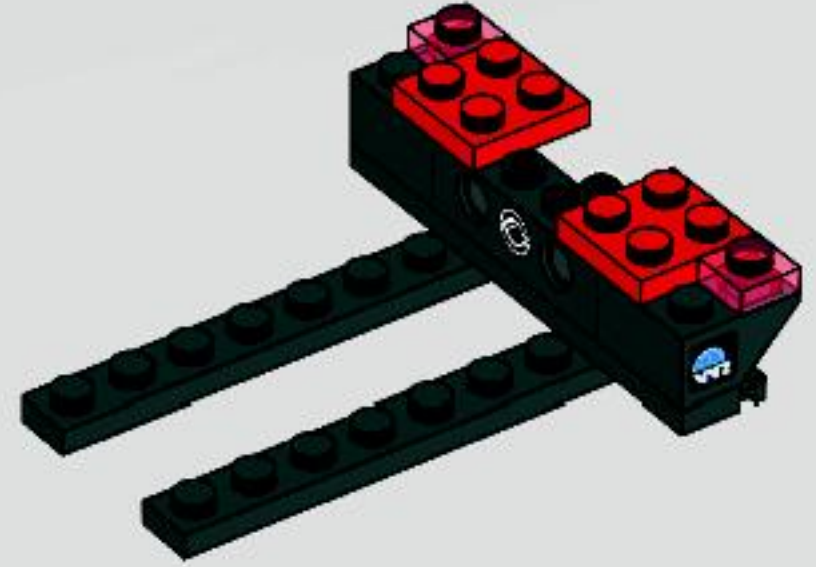

2x

5



2x

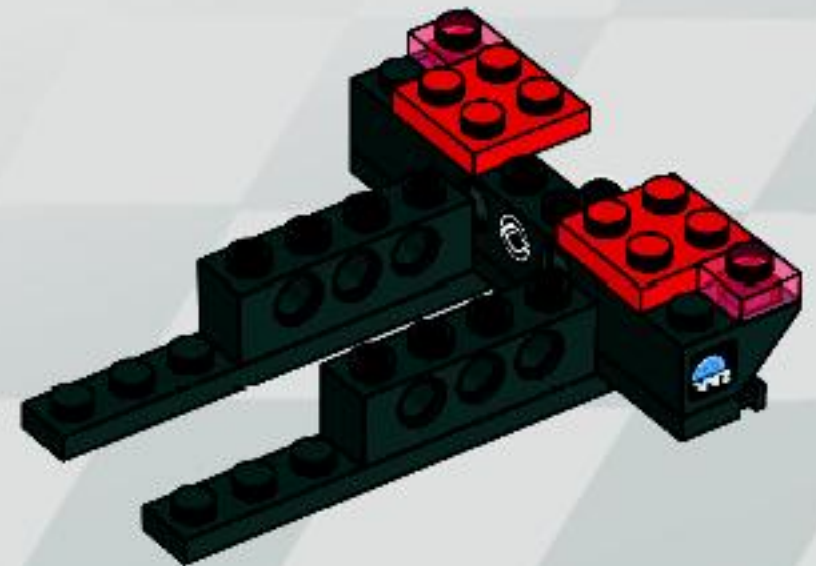

7

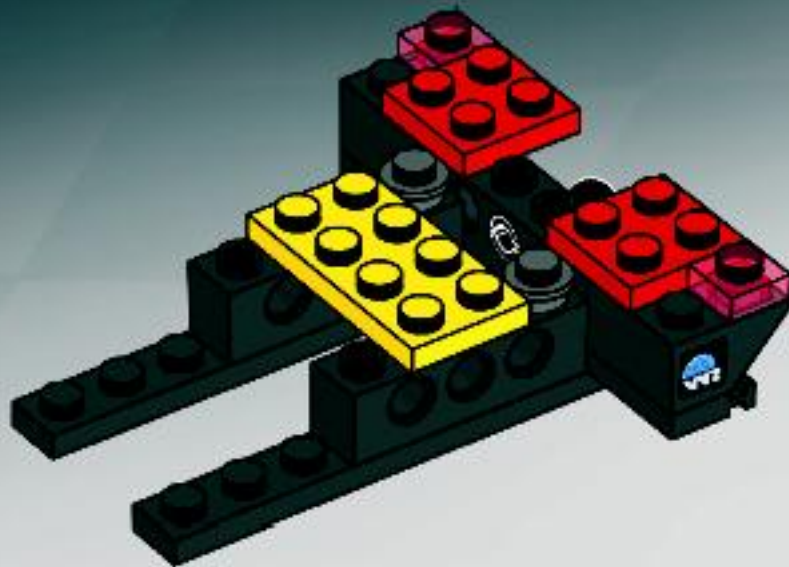

1x  2x 

8

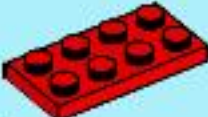

1x  2x 

9

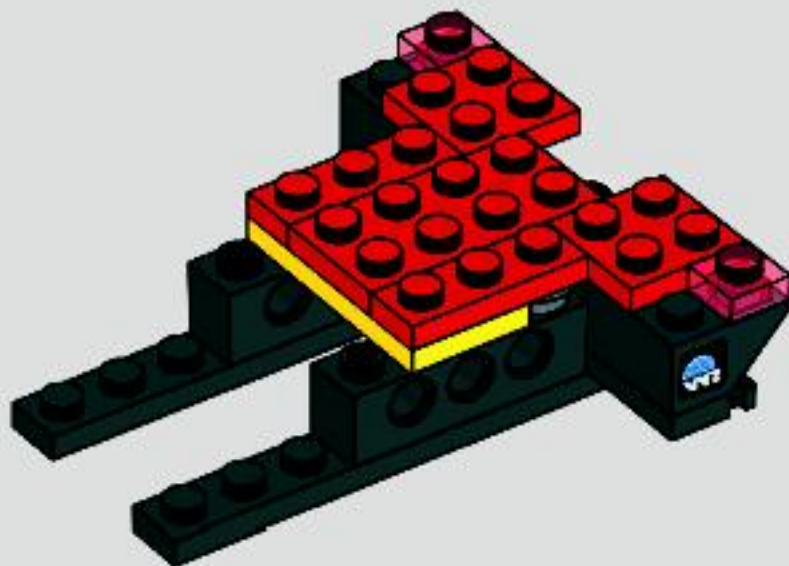

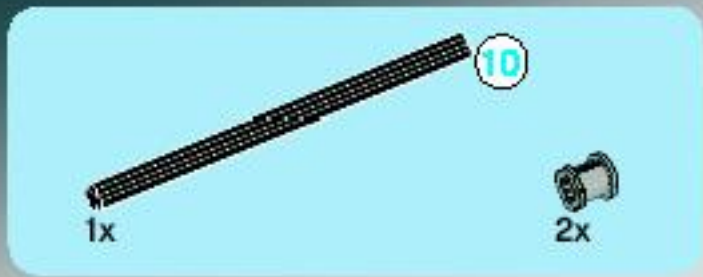

10

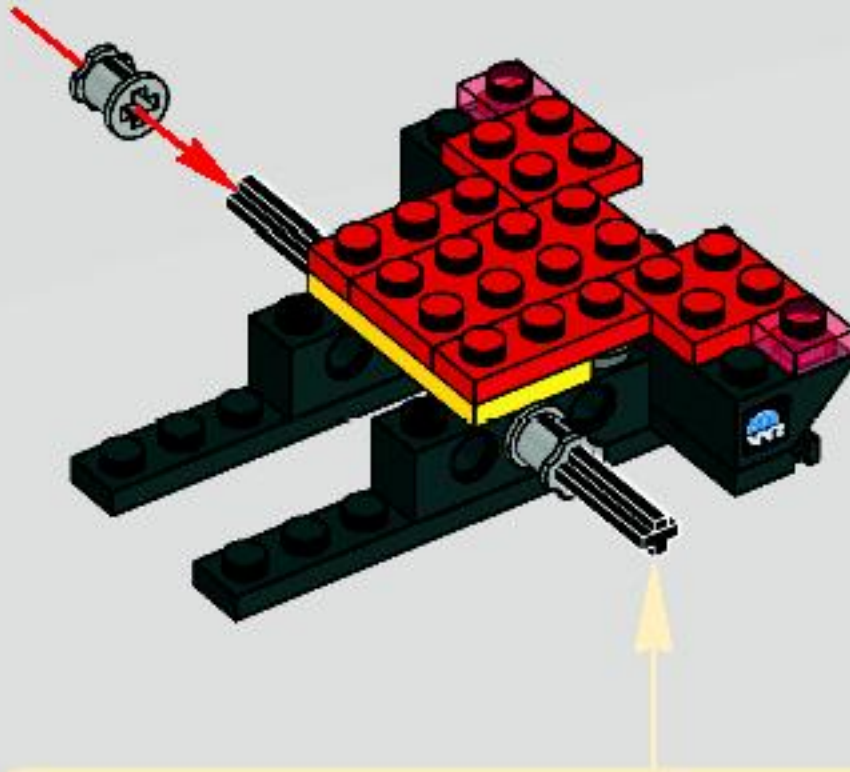

11

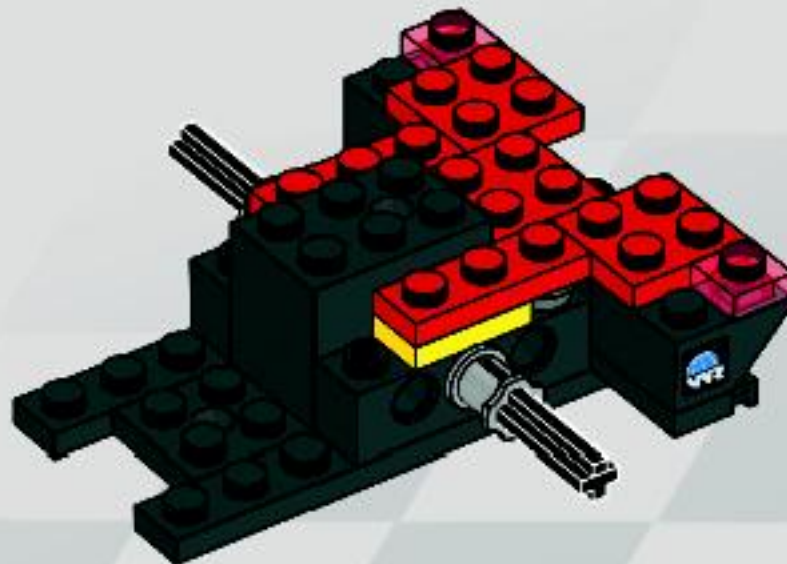

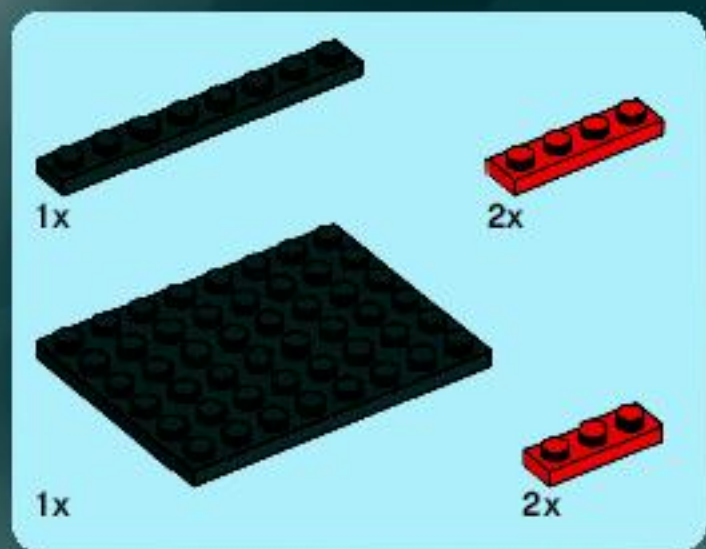

12

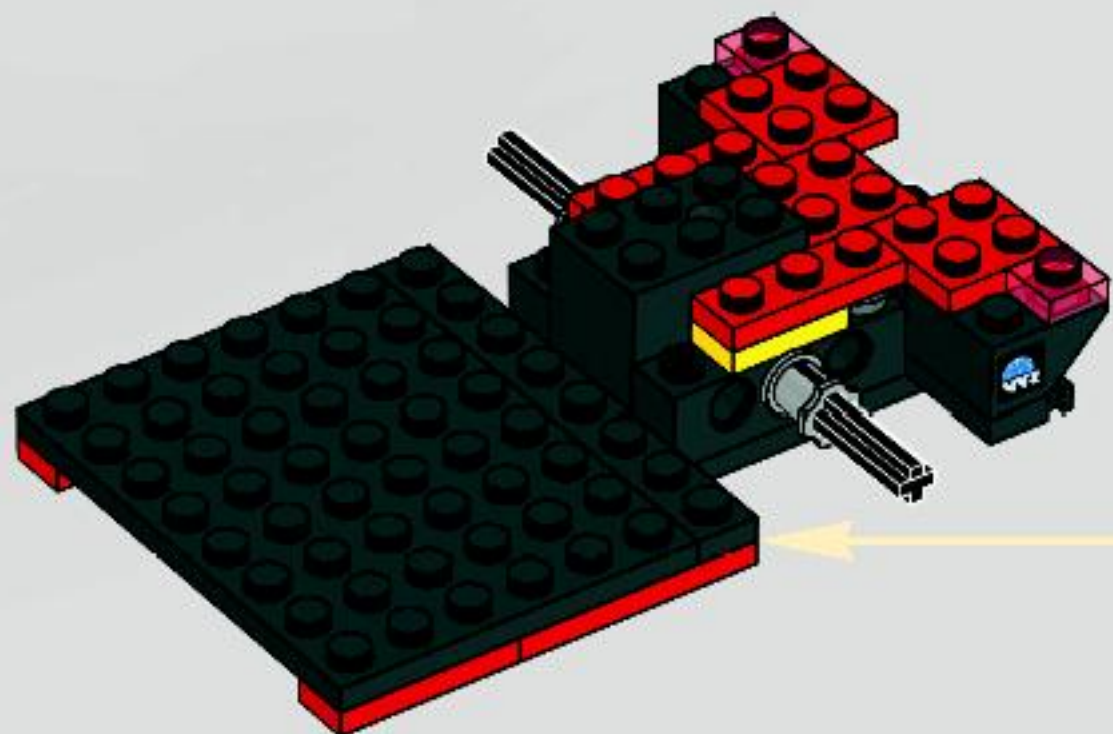

1



2



3

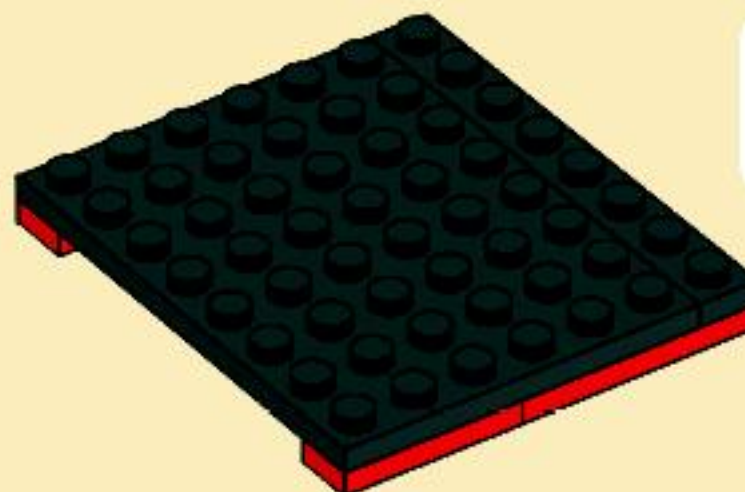



4x

13

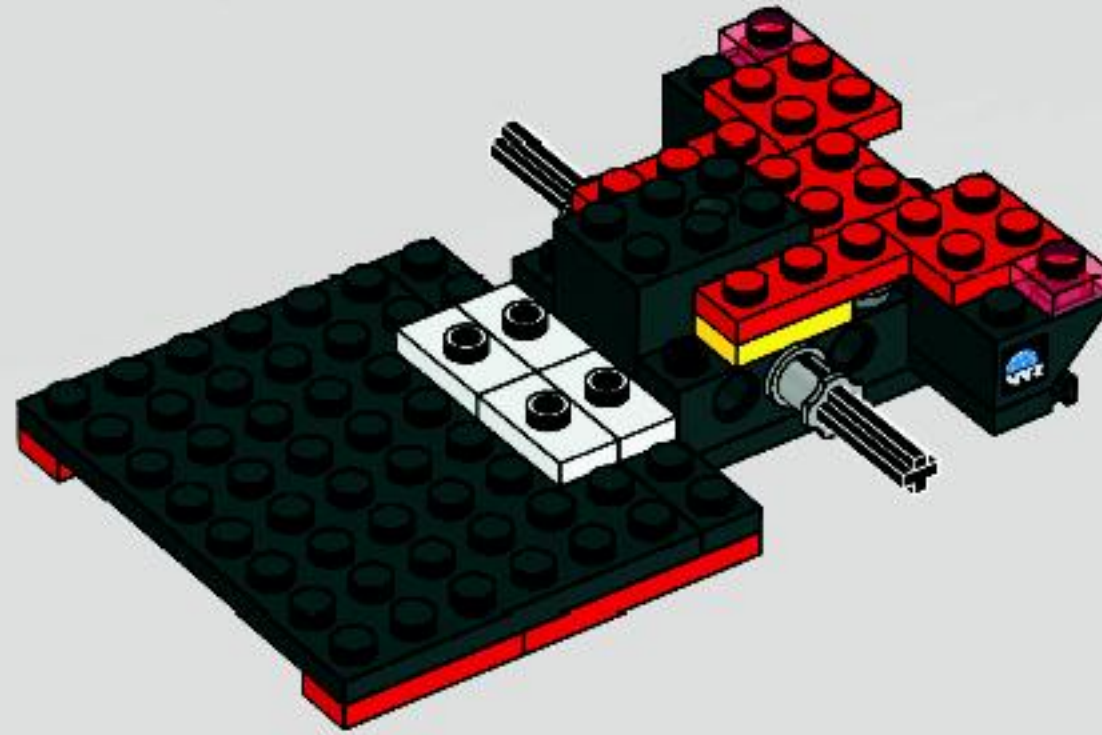

1x



2x

14

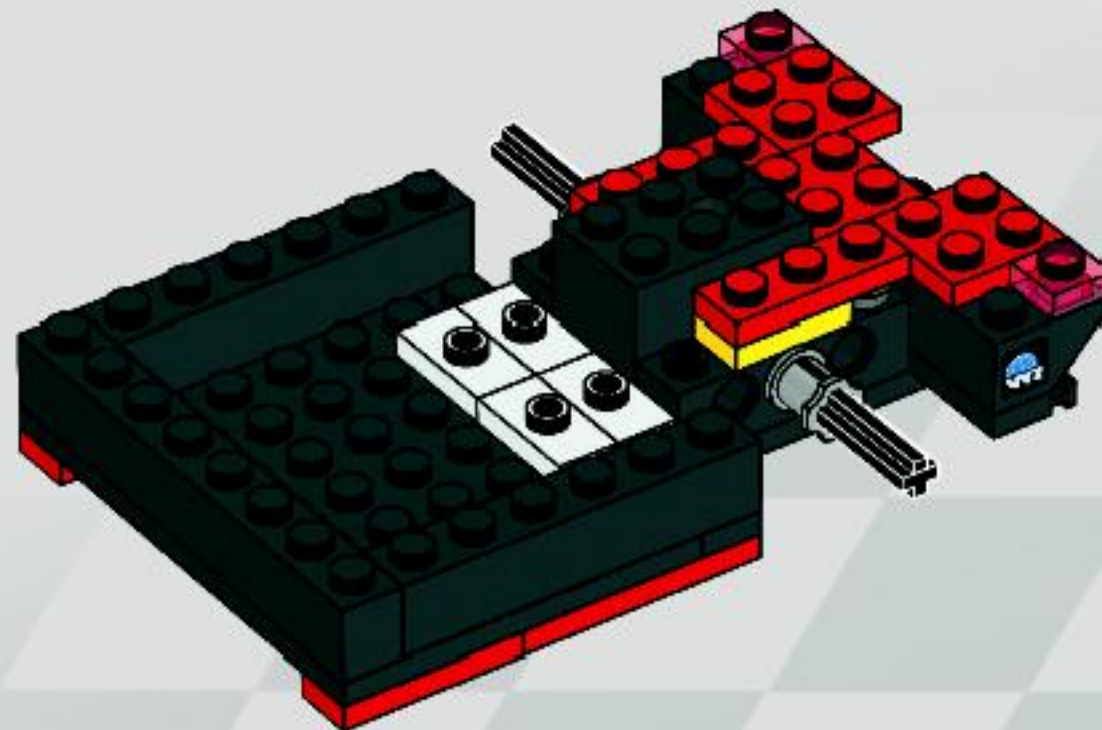



1x

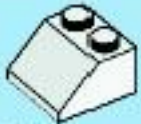

1x

15

1



2

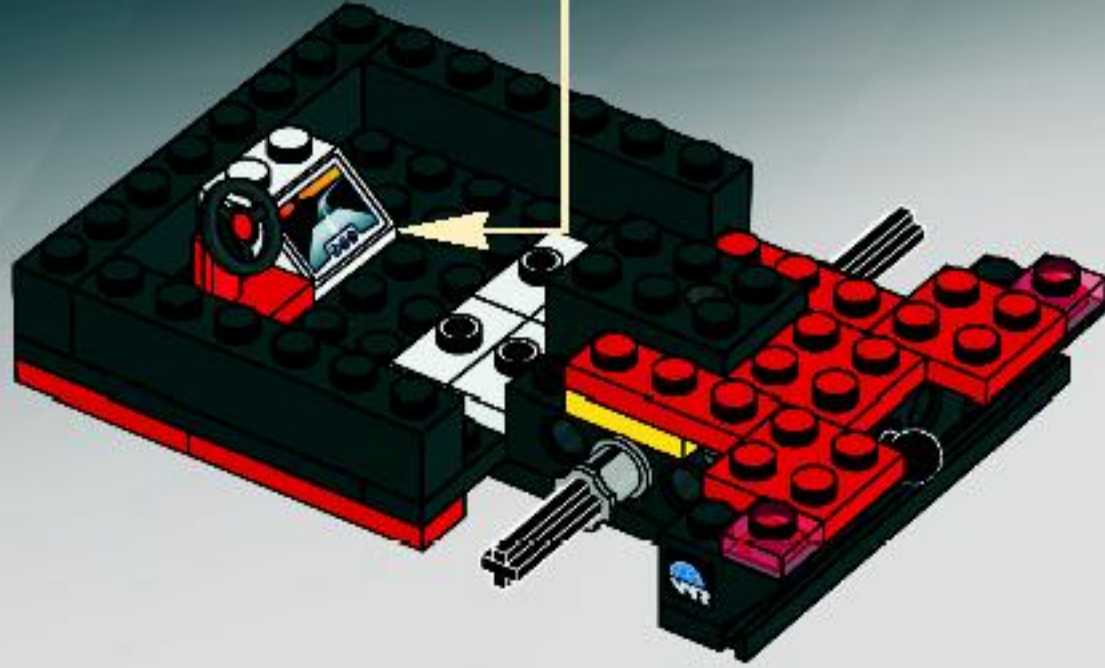

2x



2x

16

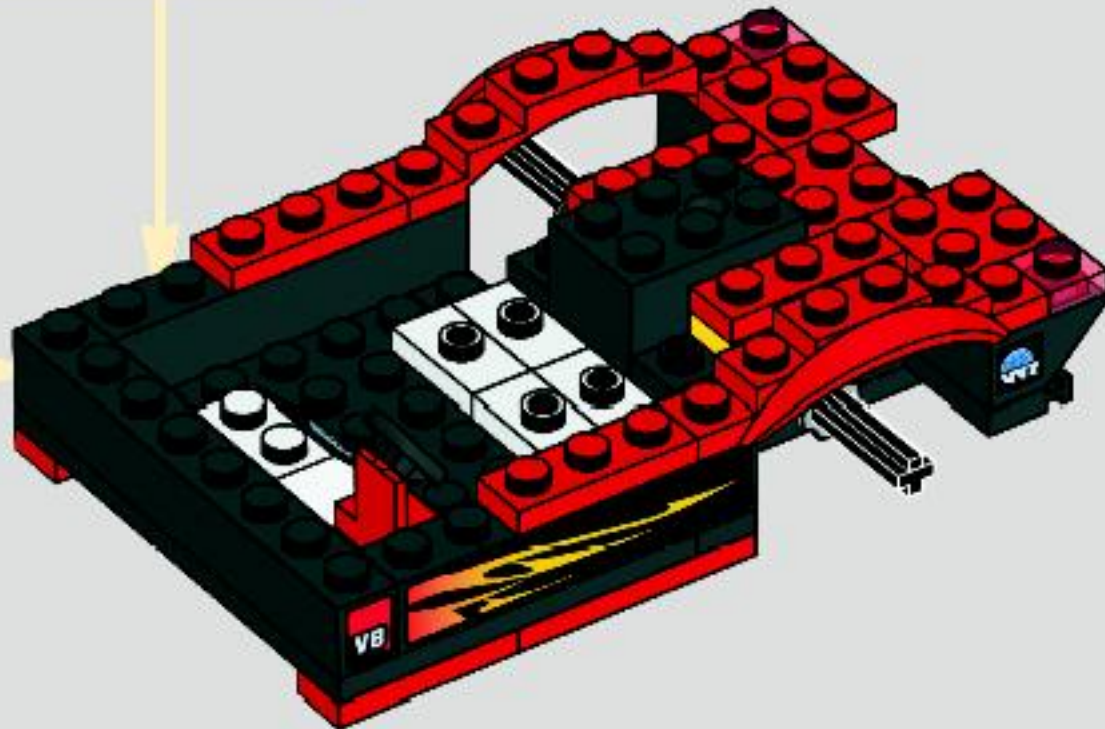



1x



4x

17

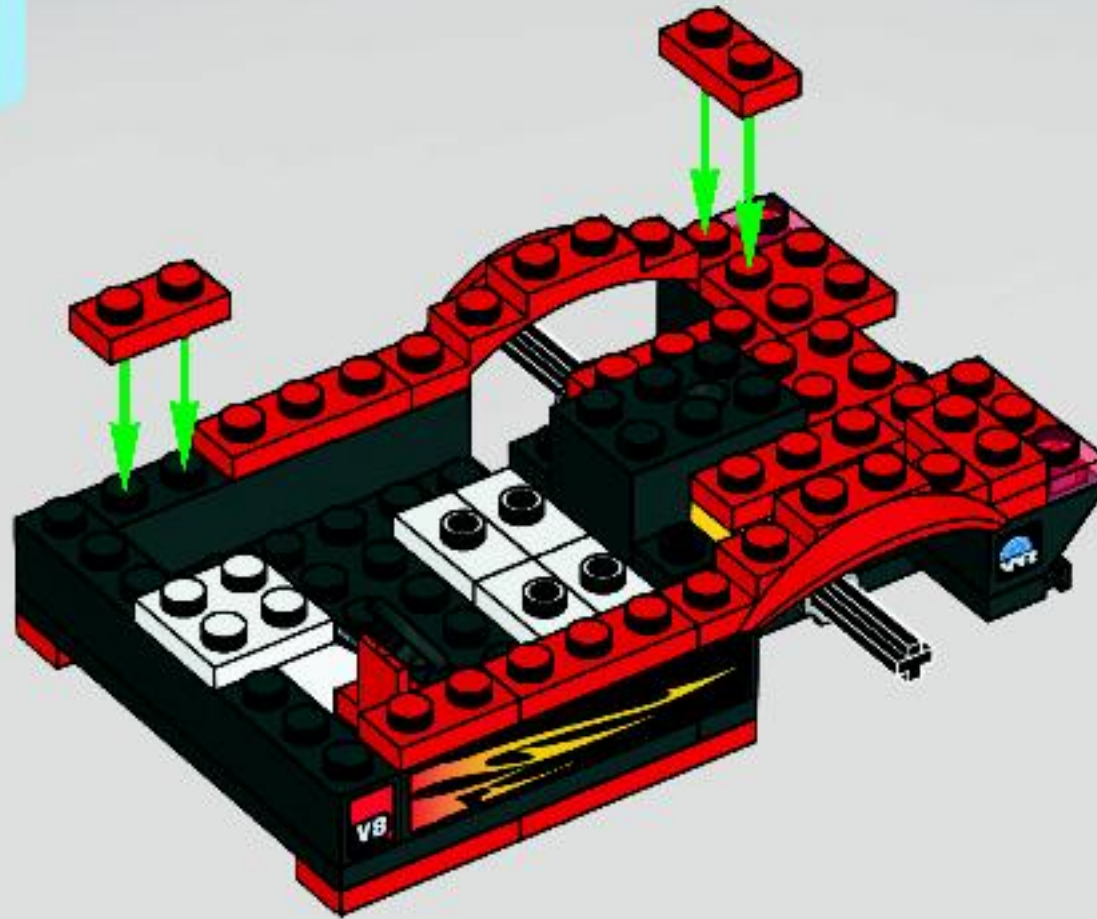

2x



2x



2x

18

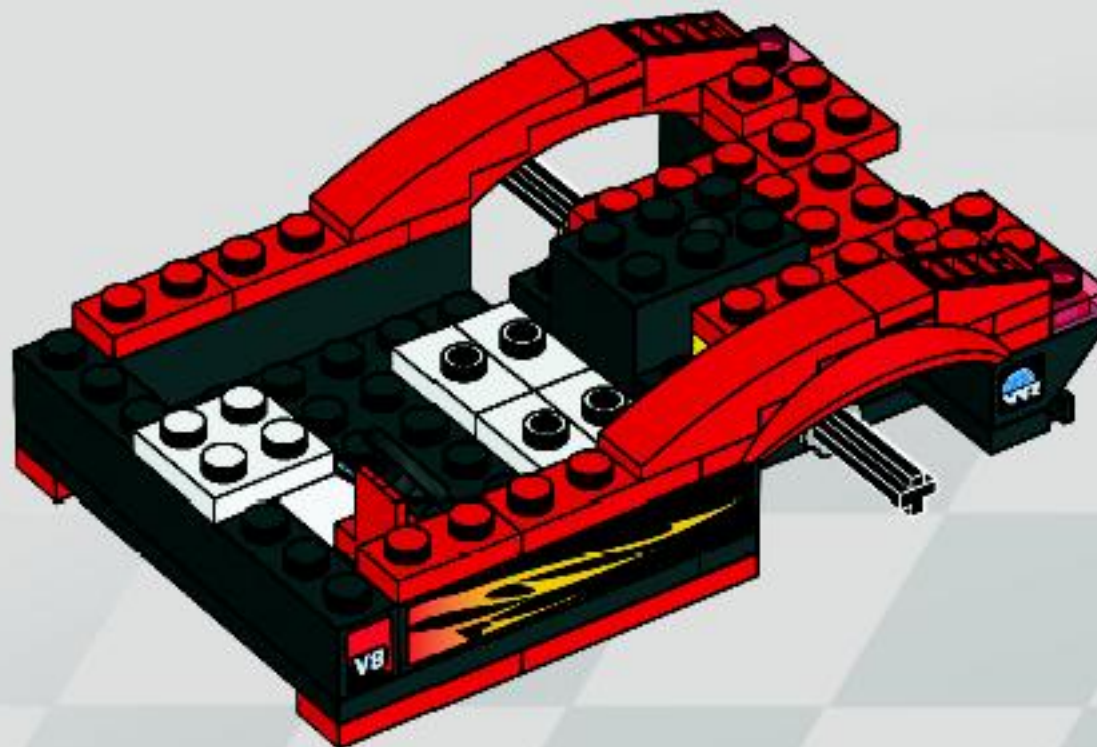

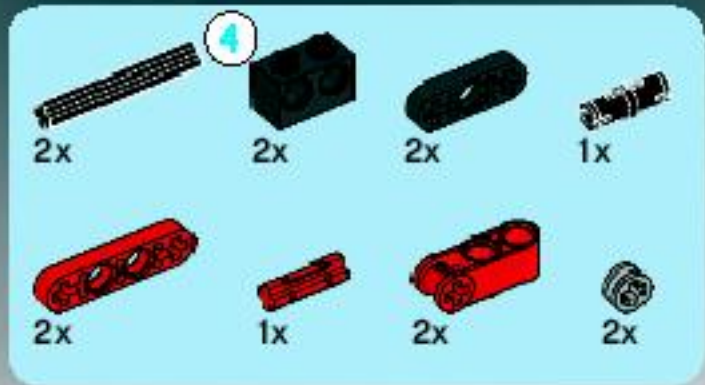

19

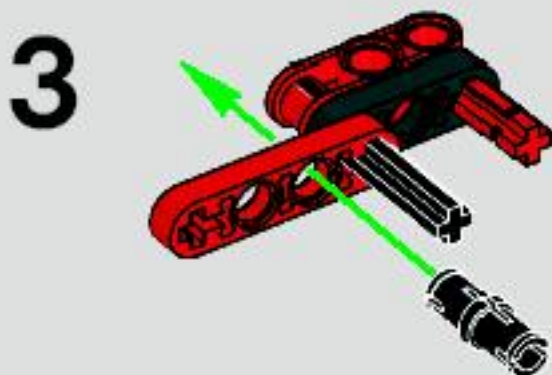
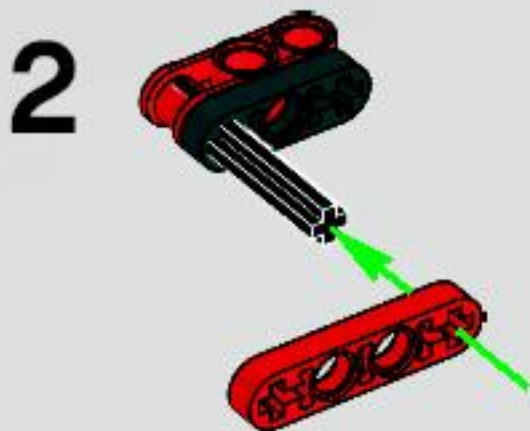

4

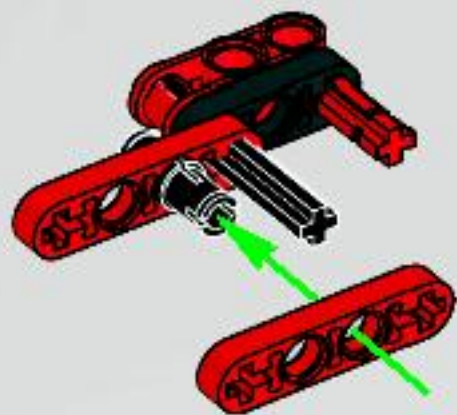

6

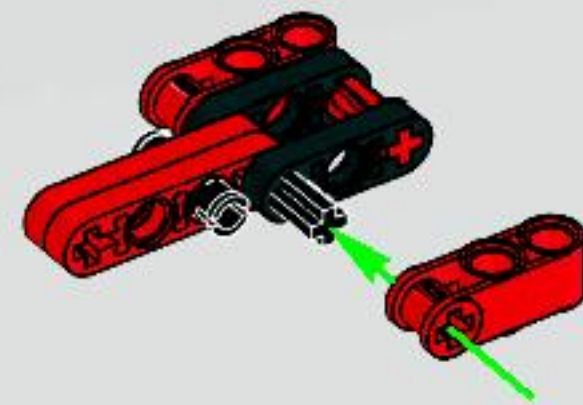

5



7

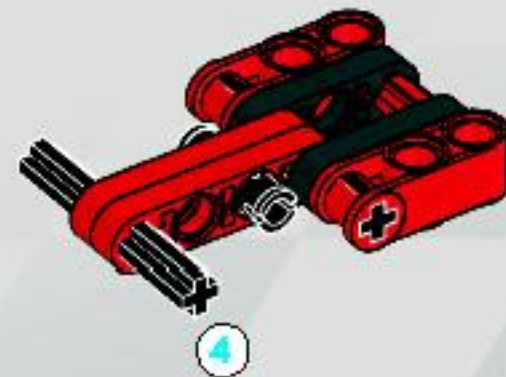

8



9

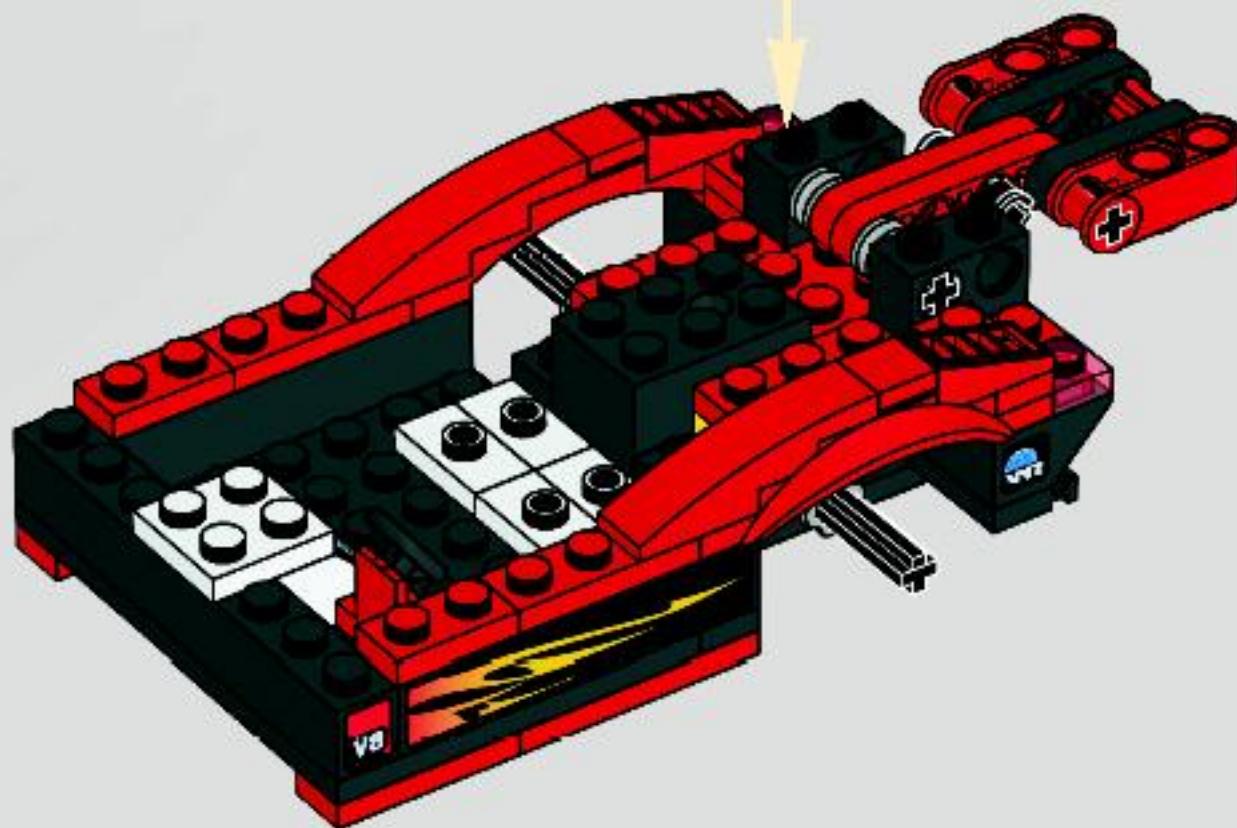



2x

20

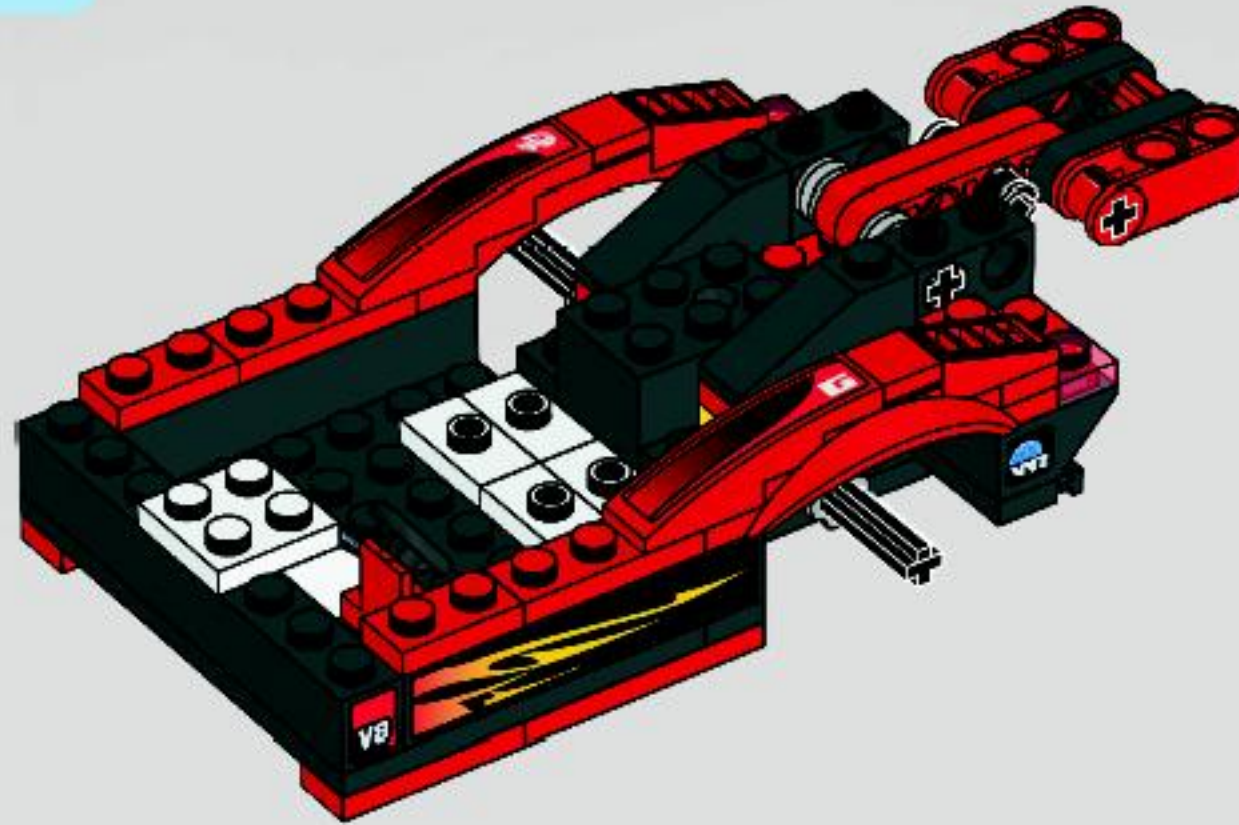

2x

21

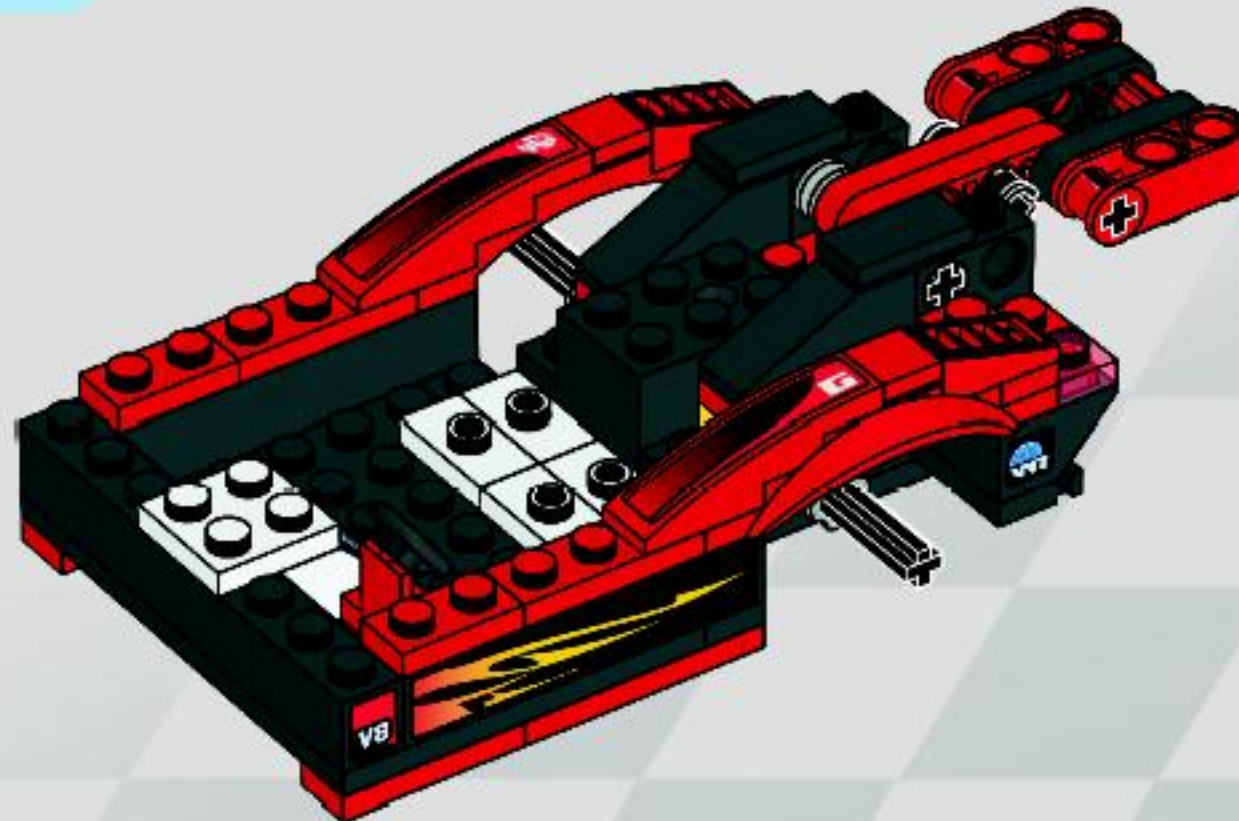

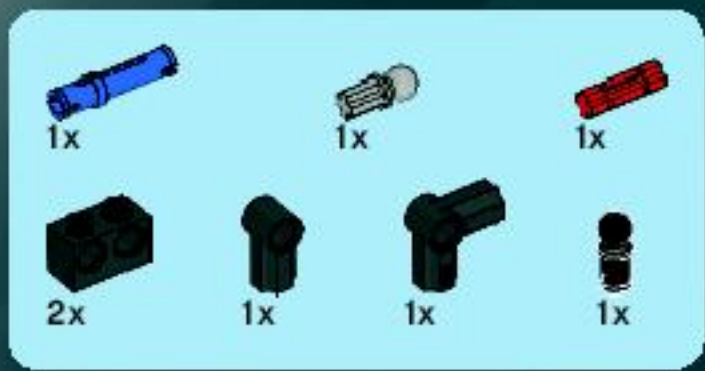

22

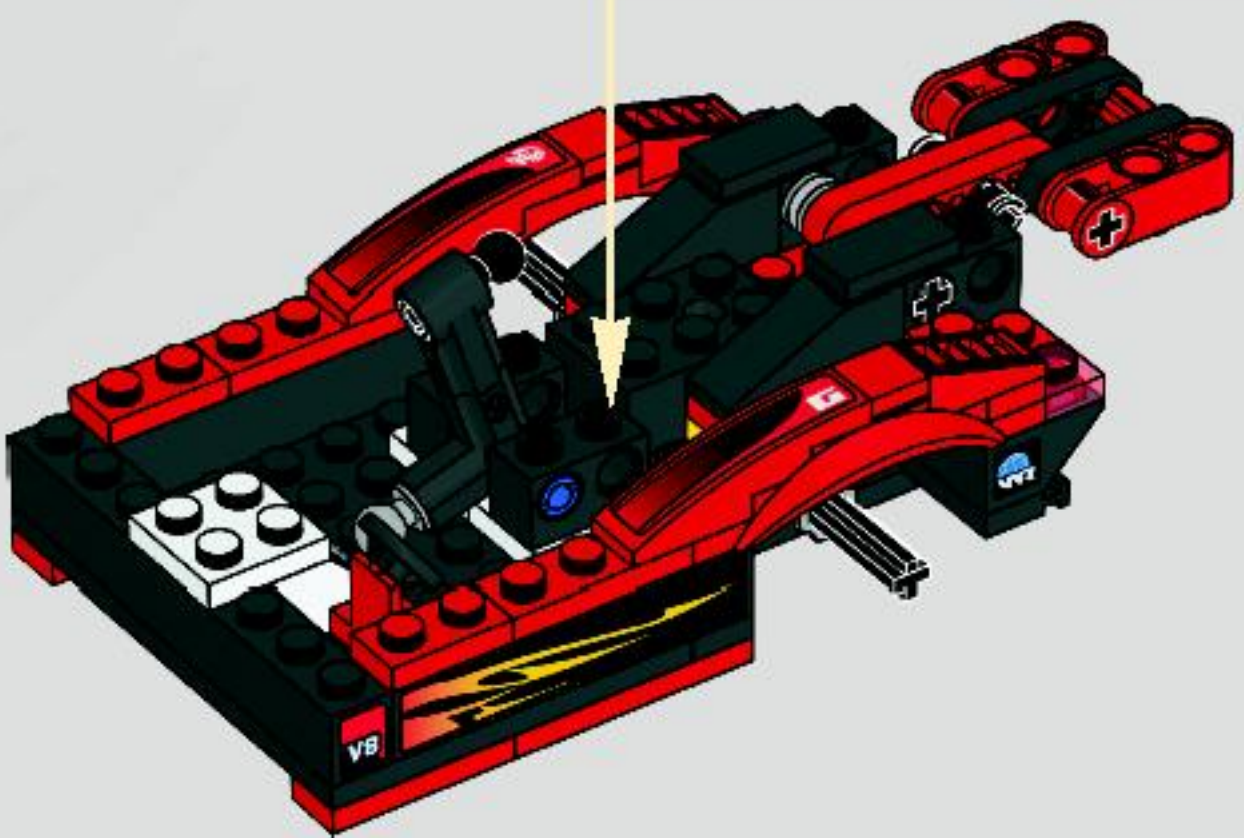
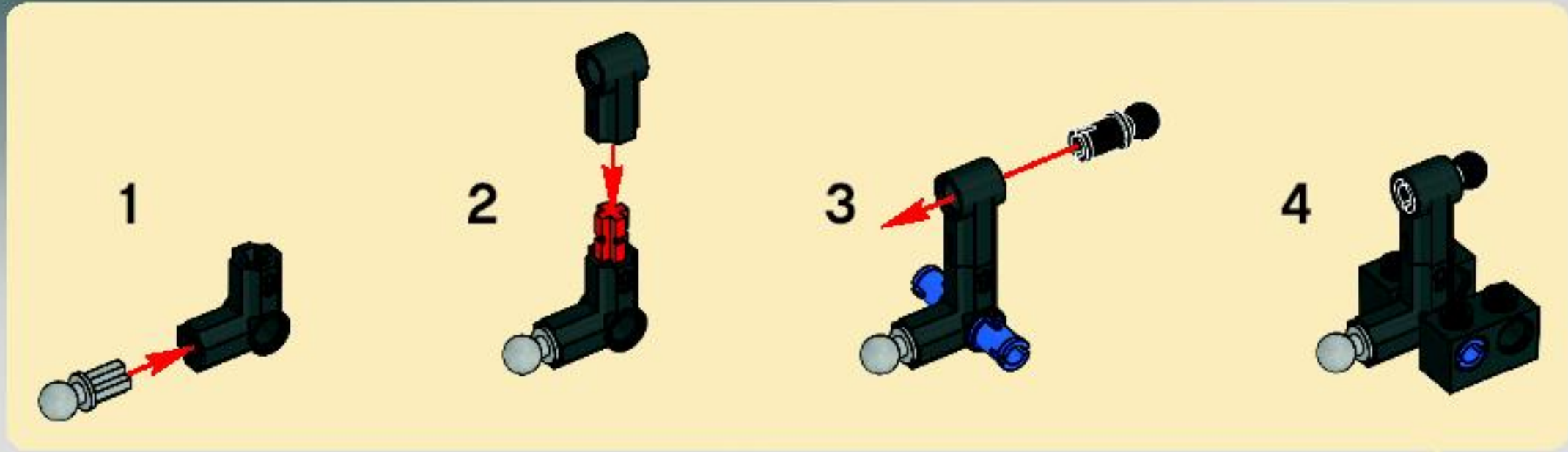



1x

23

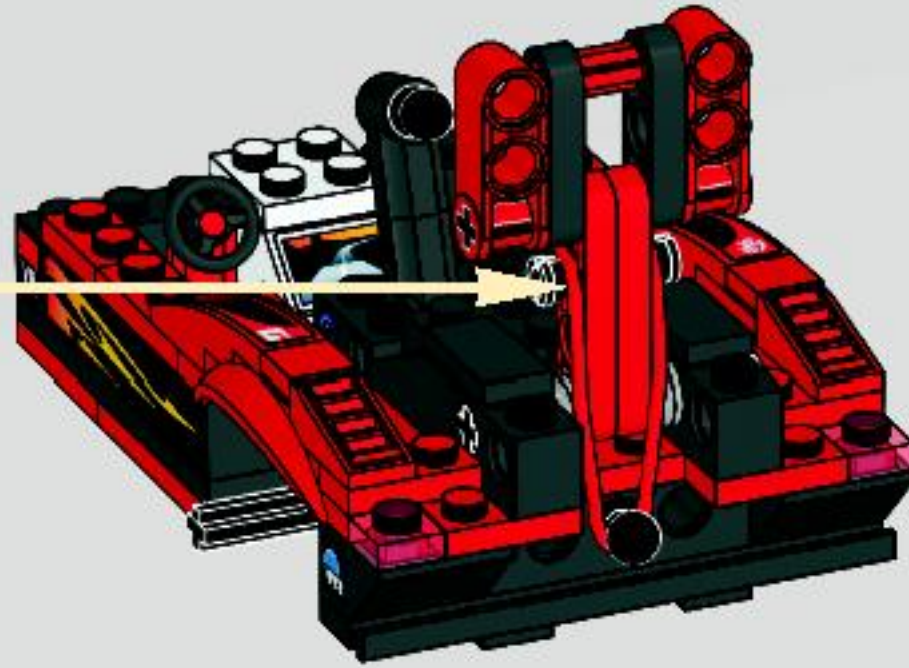

24

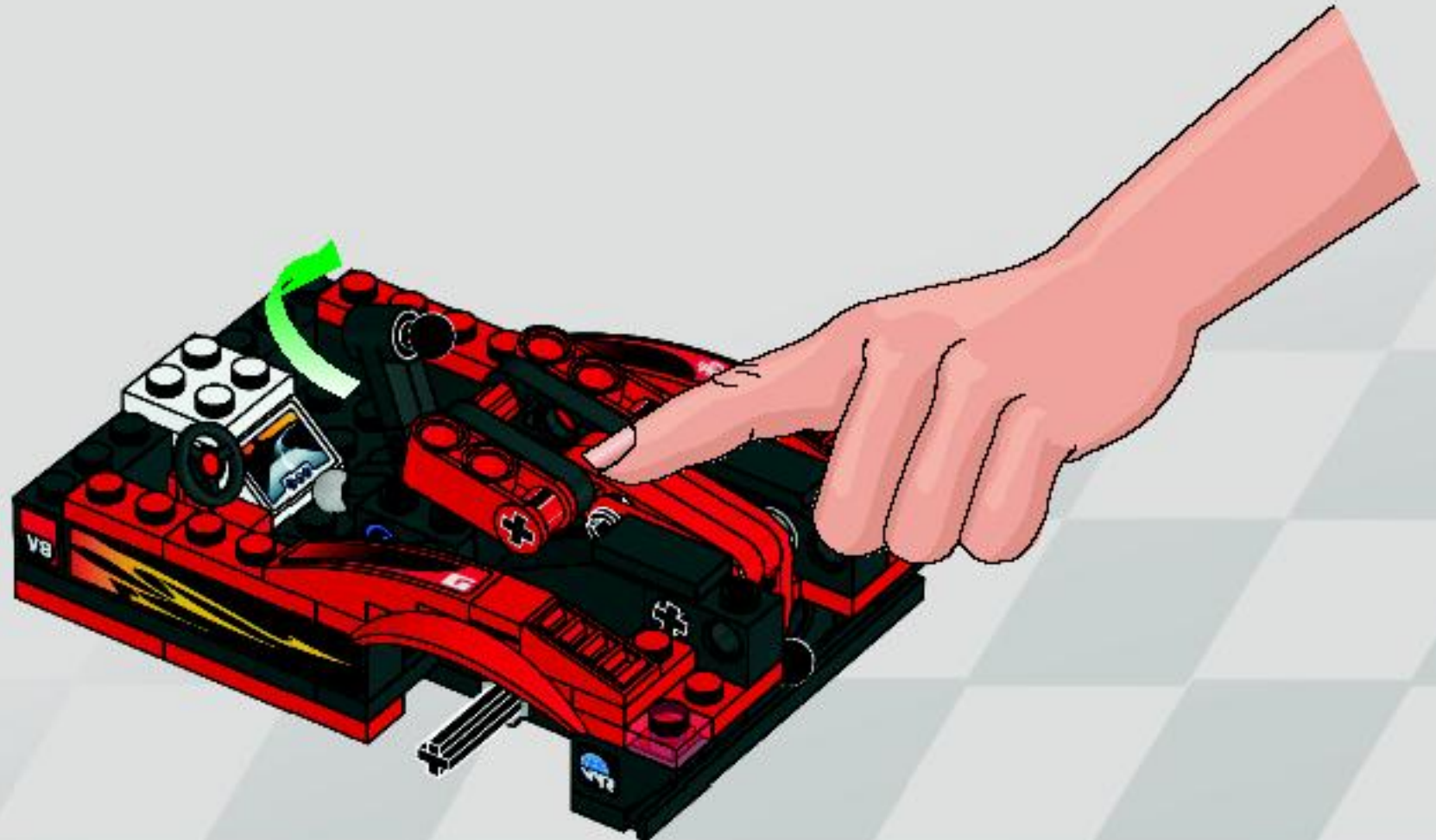



2x

25

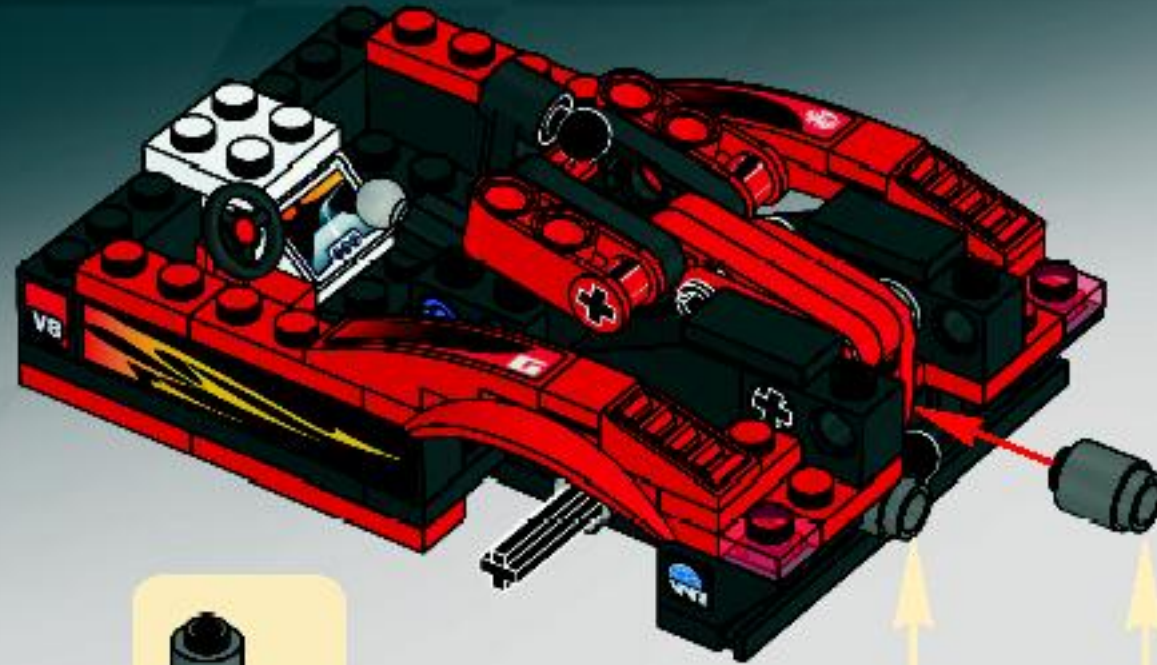

2x



1x



2x

26

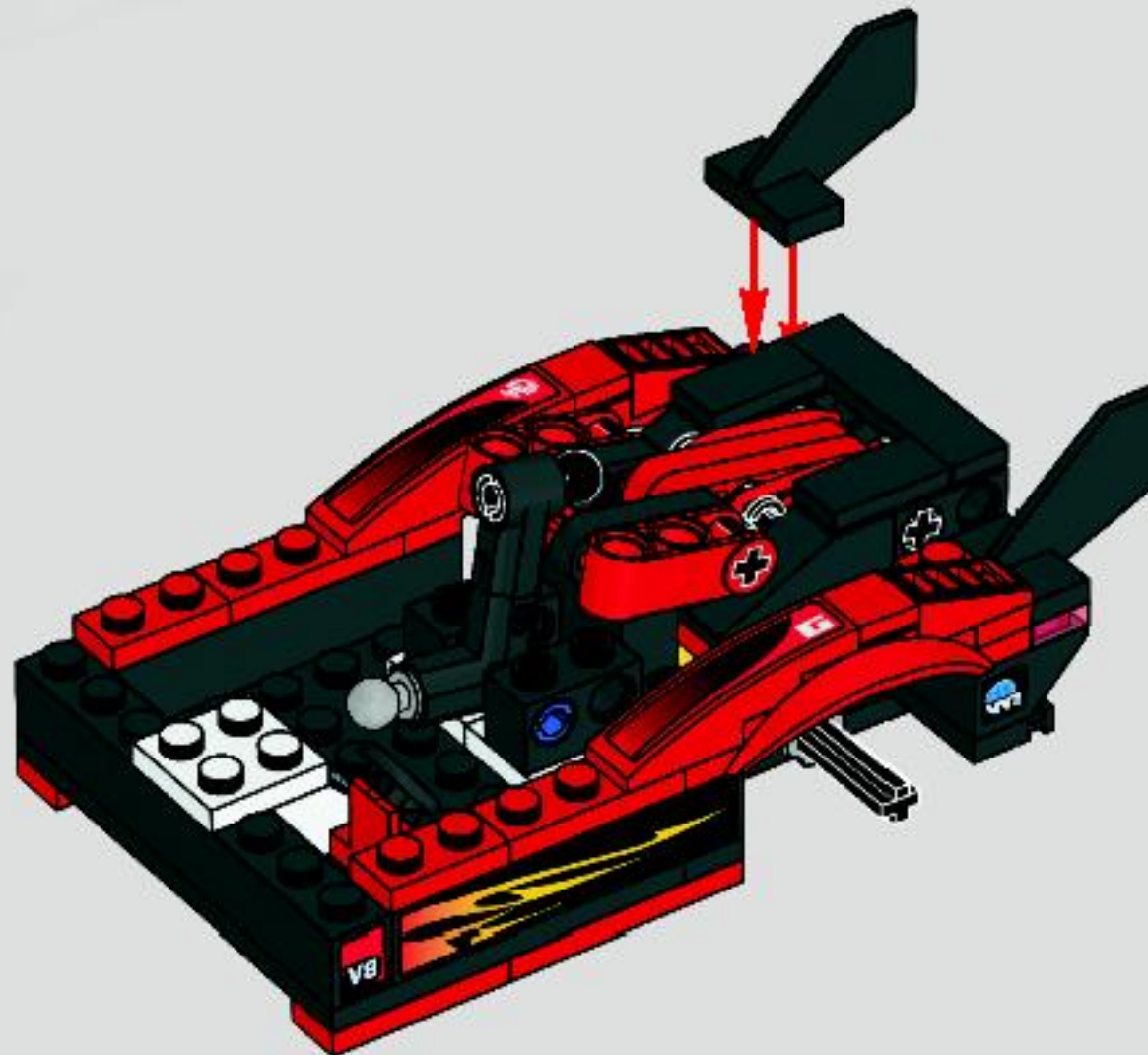



4x

27

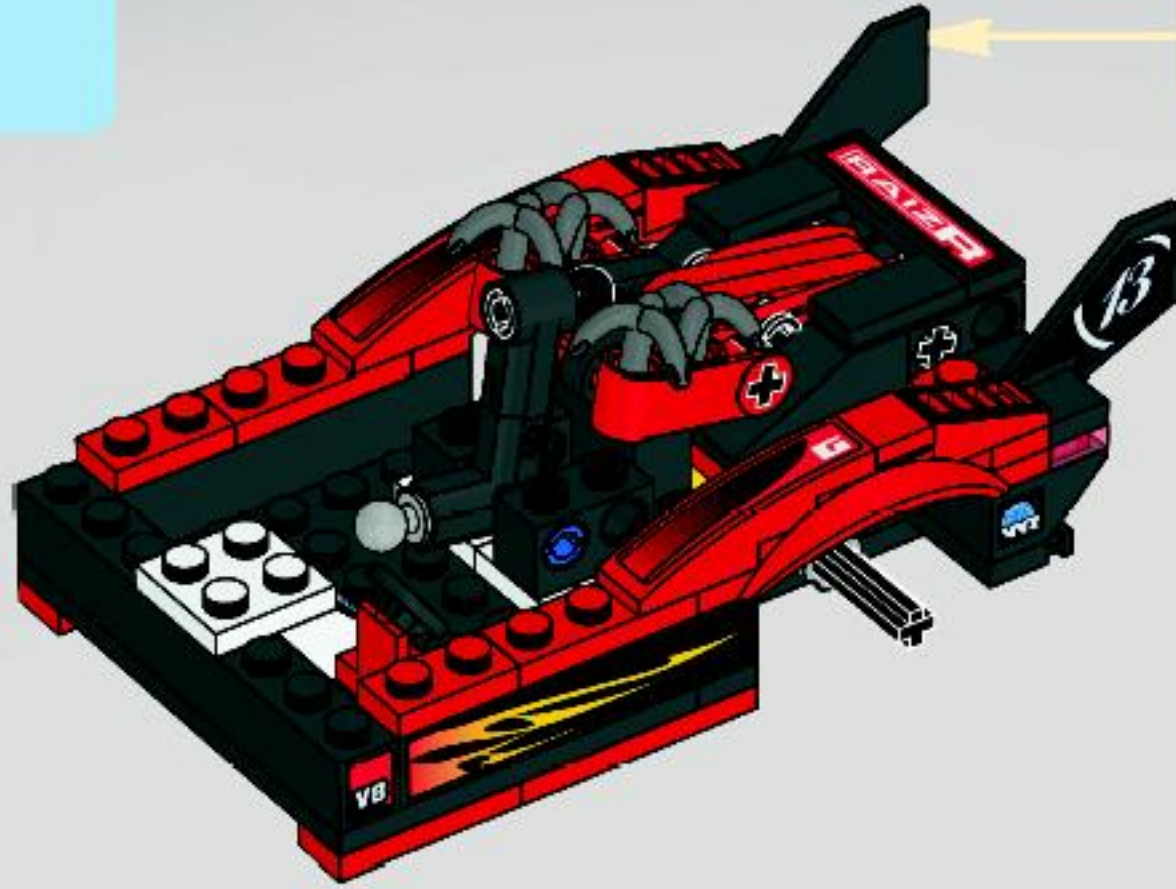

28

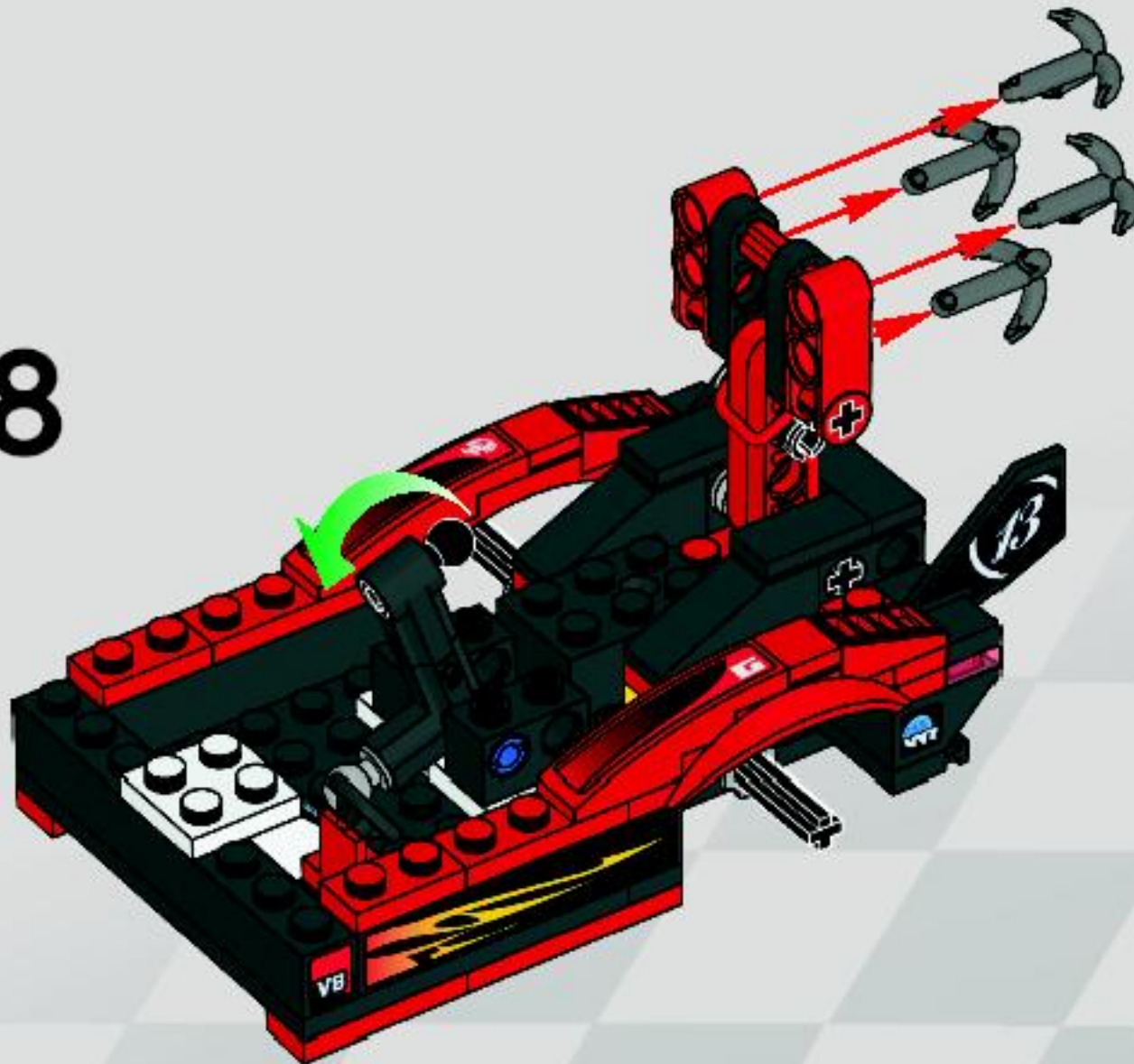



1x

1



2x

2



2x

3



2x

4

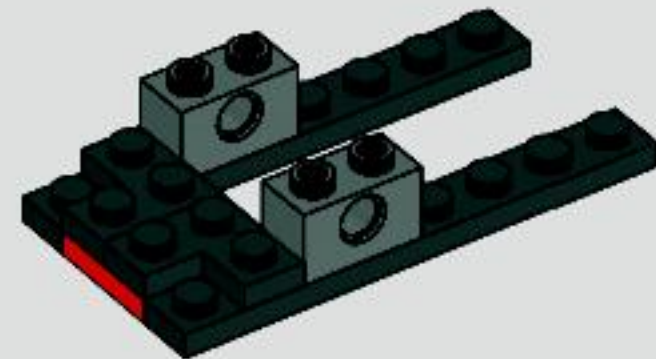



5

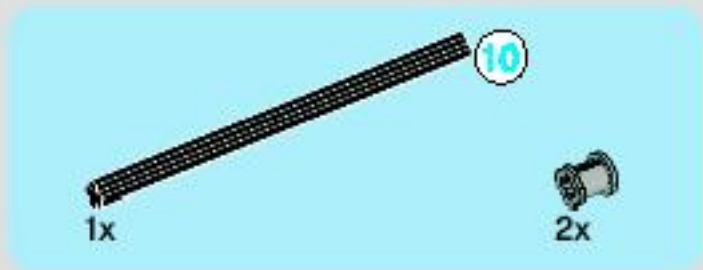
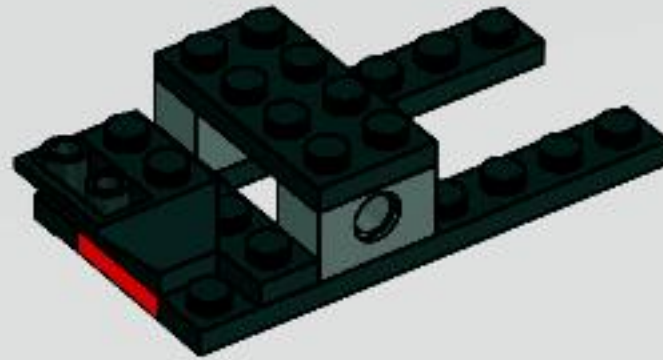

6

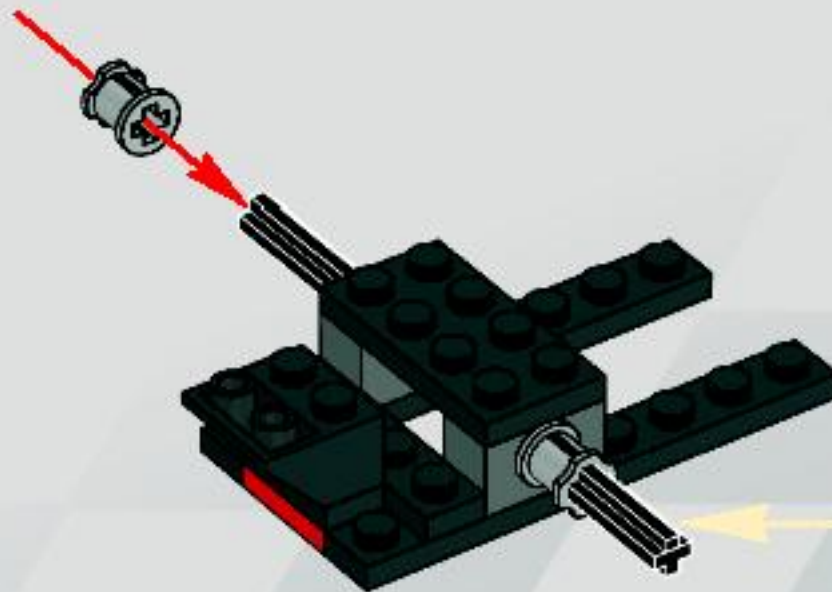
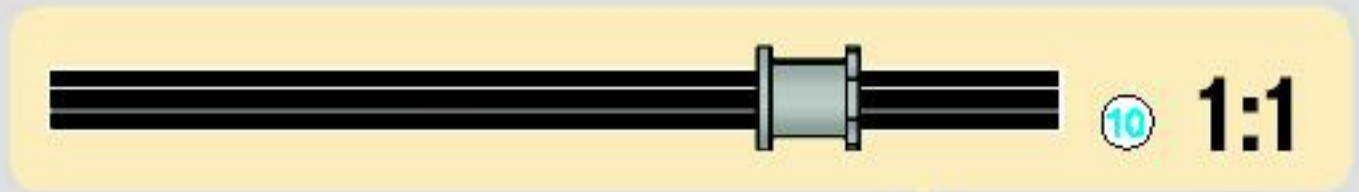



30

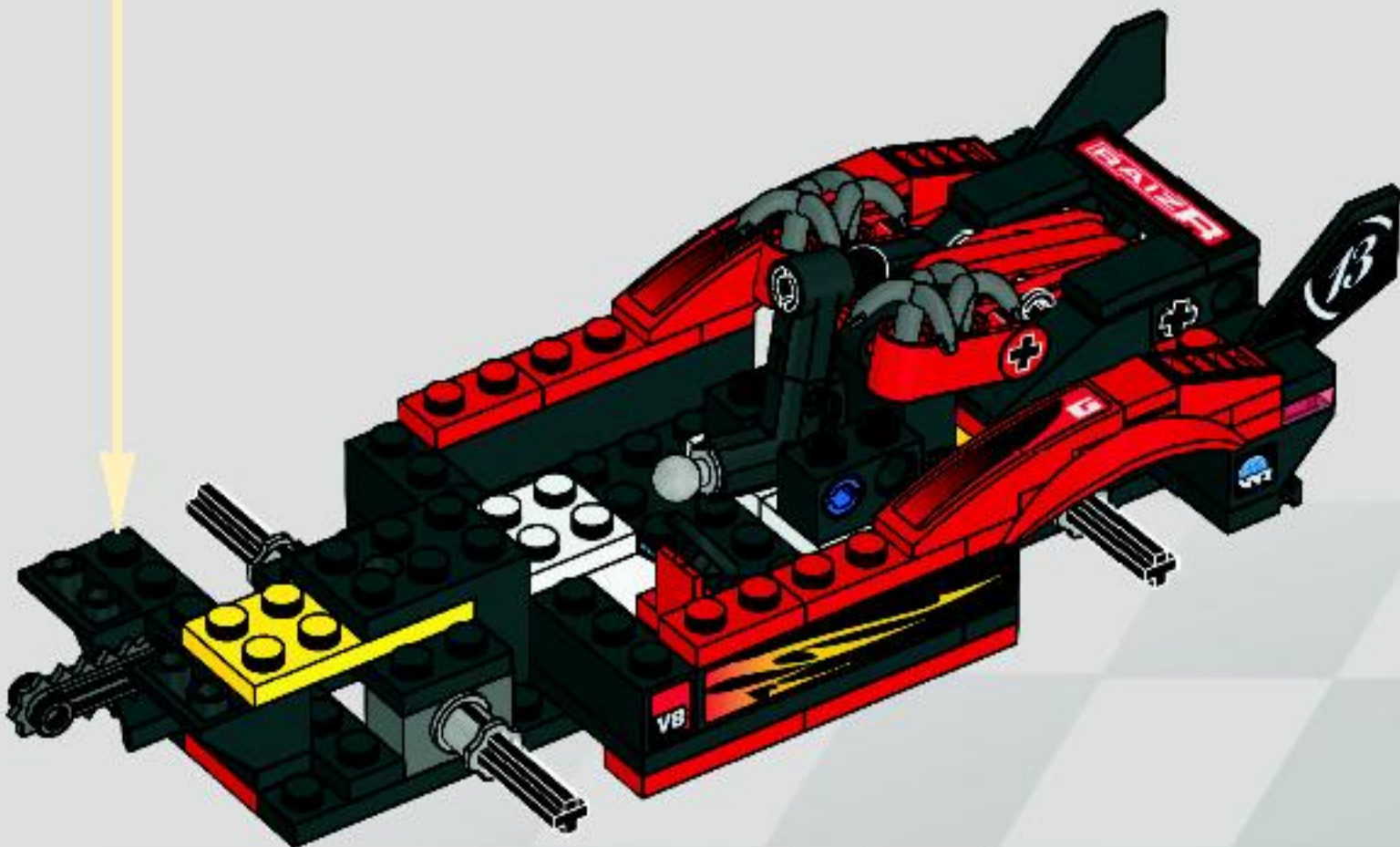



31

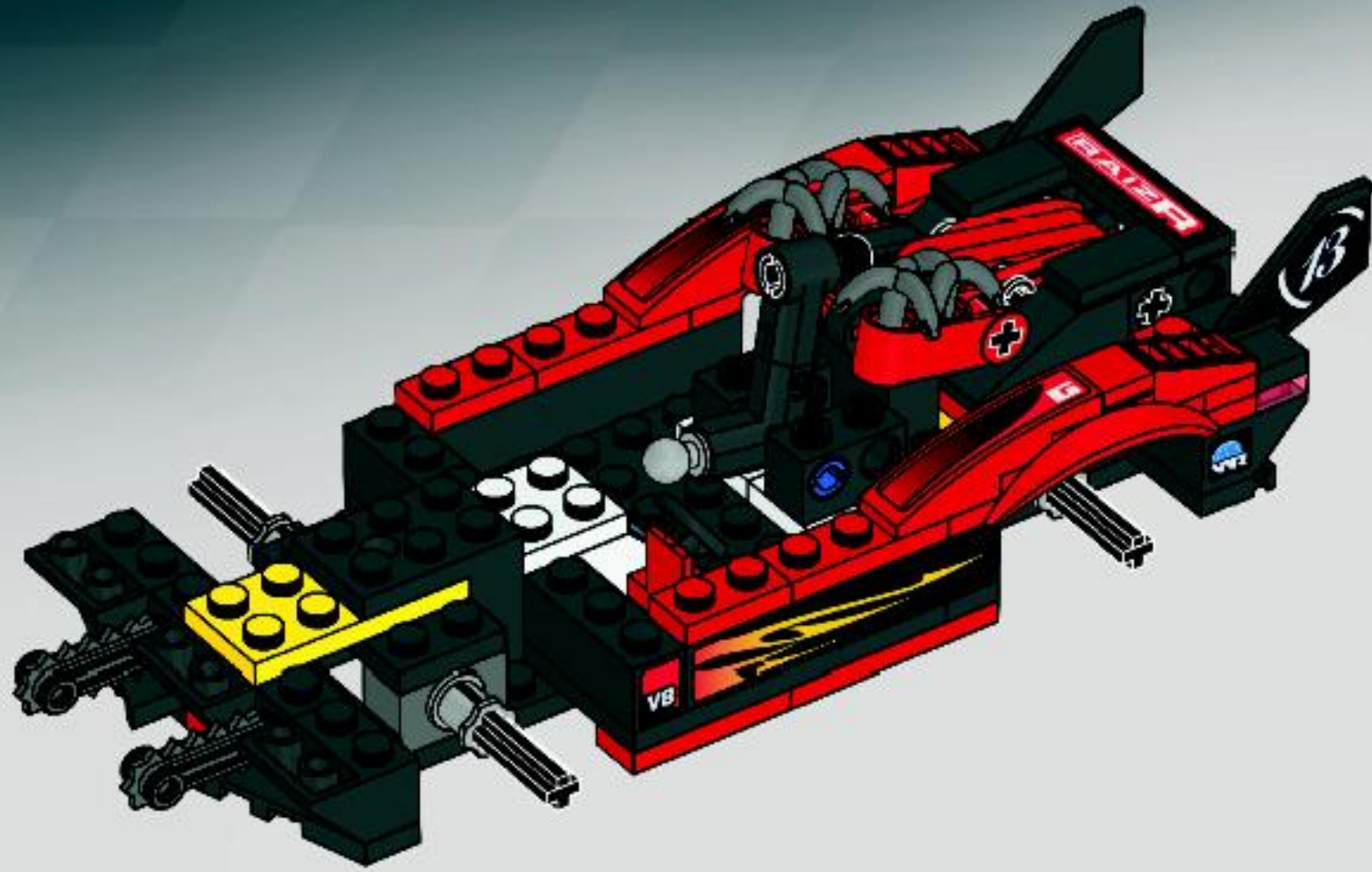



2x

32

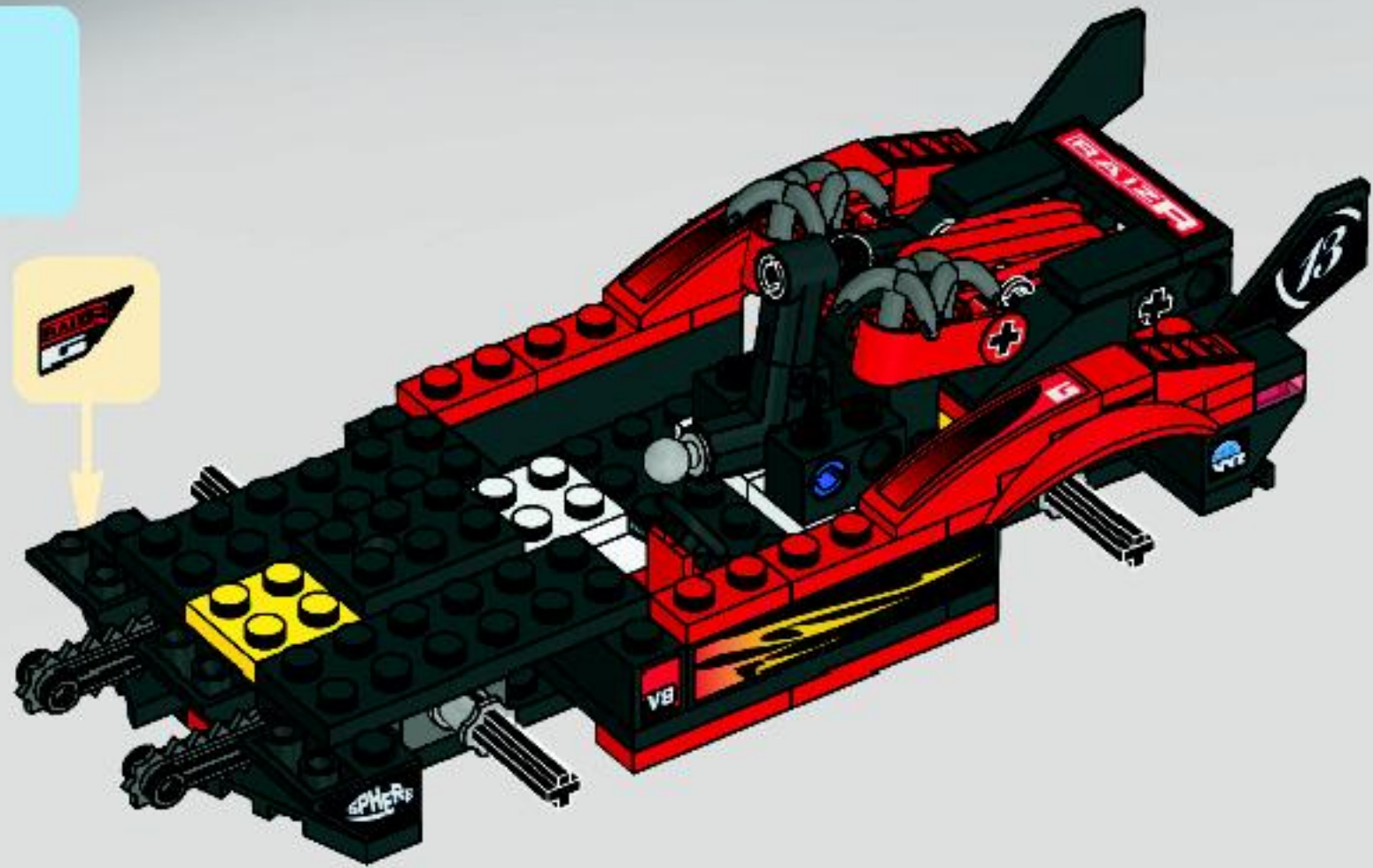

2x



1x



1x

33

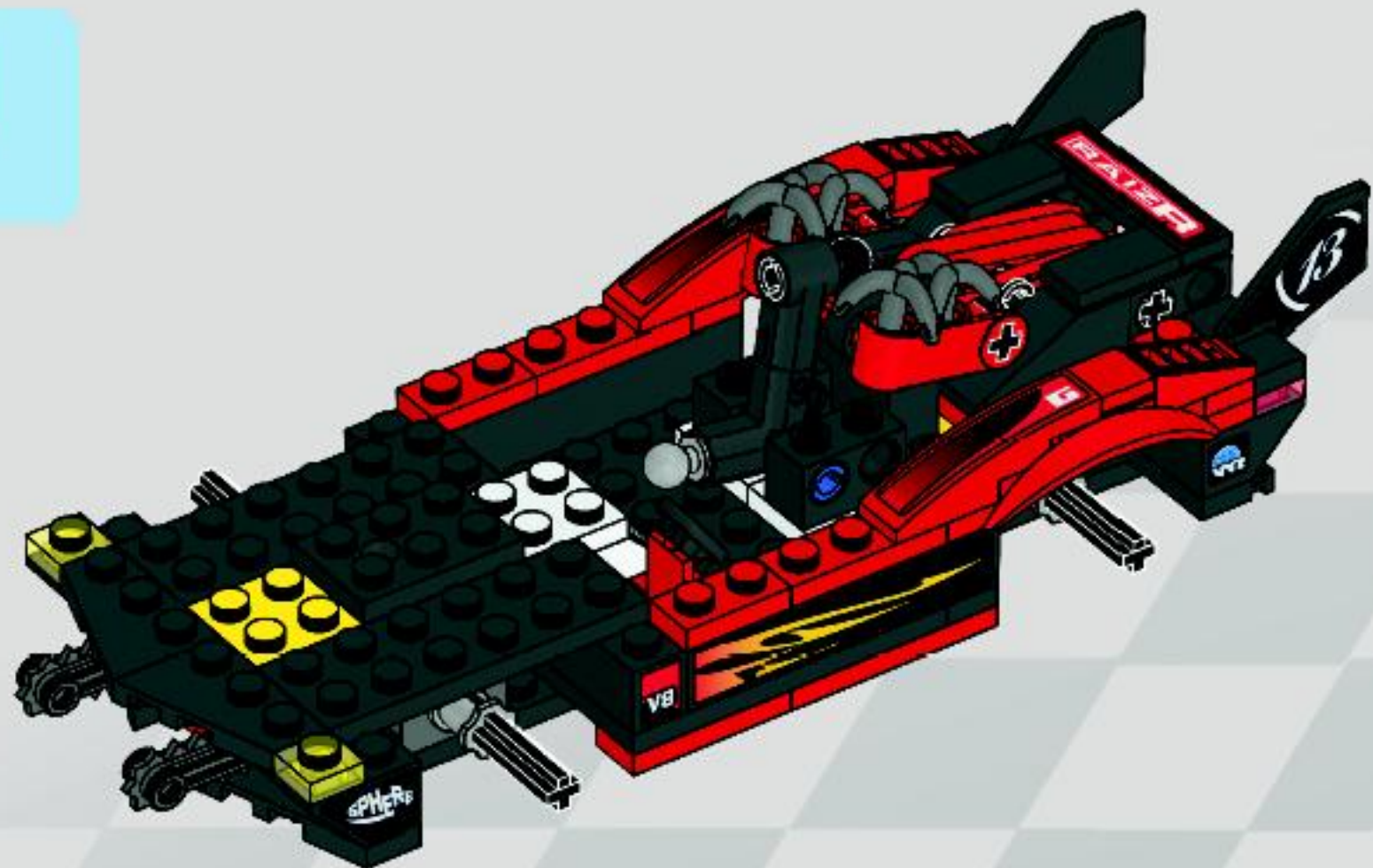

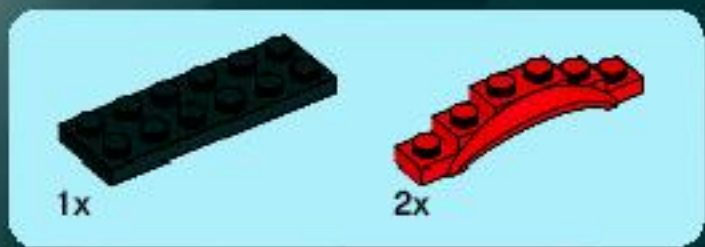

34

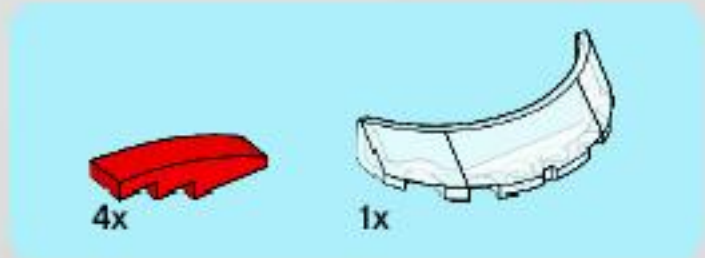
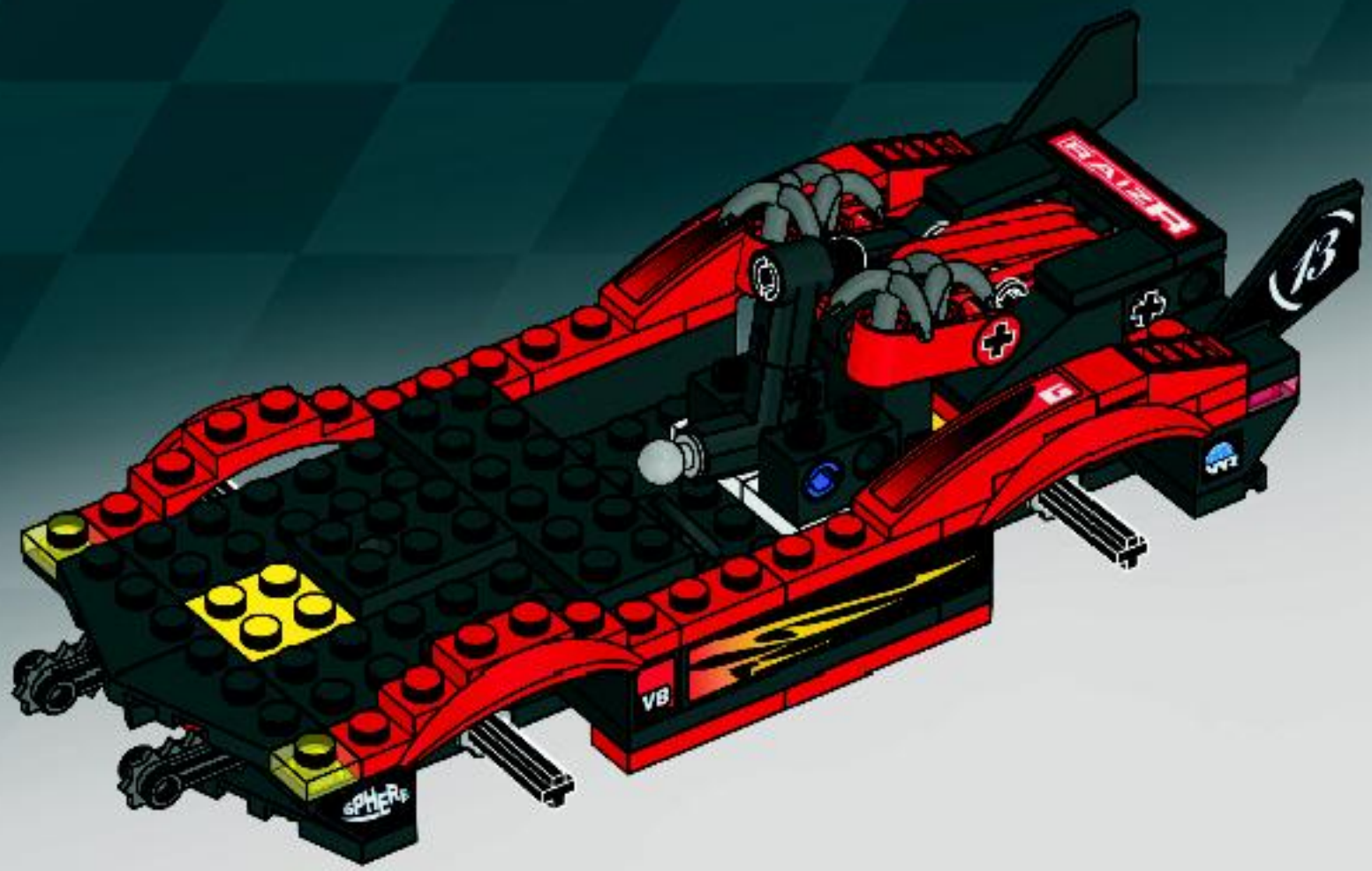

35

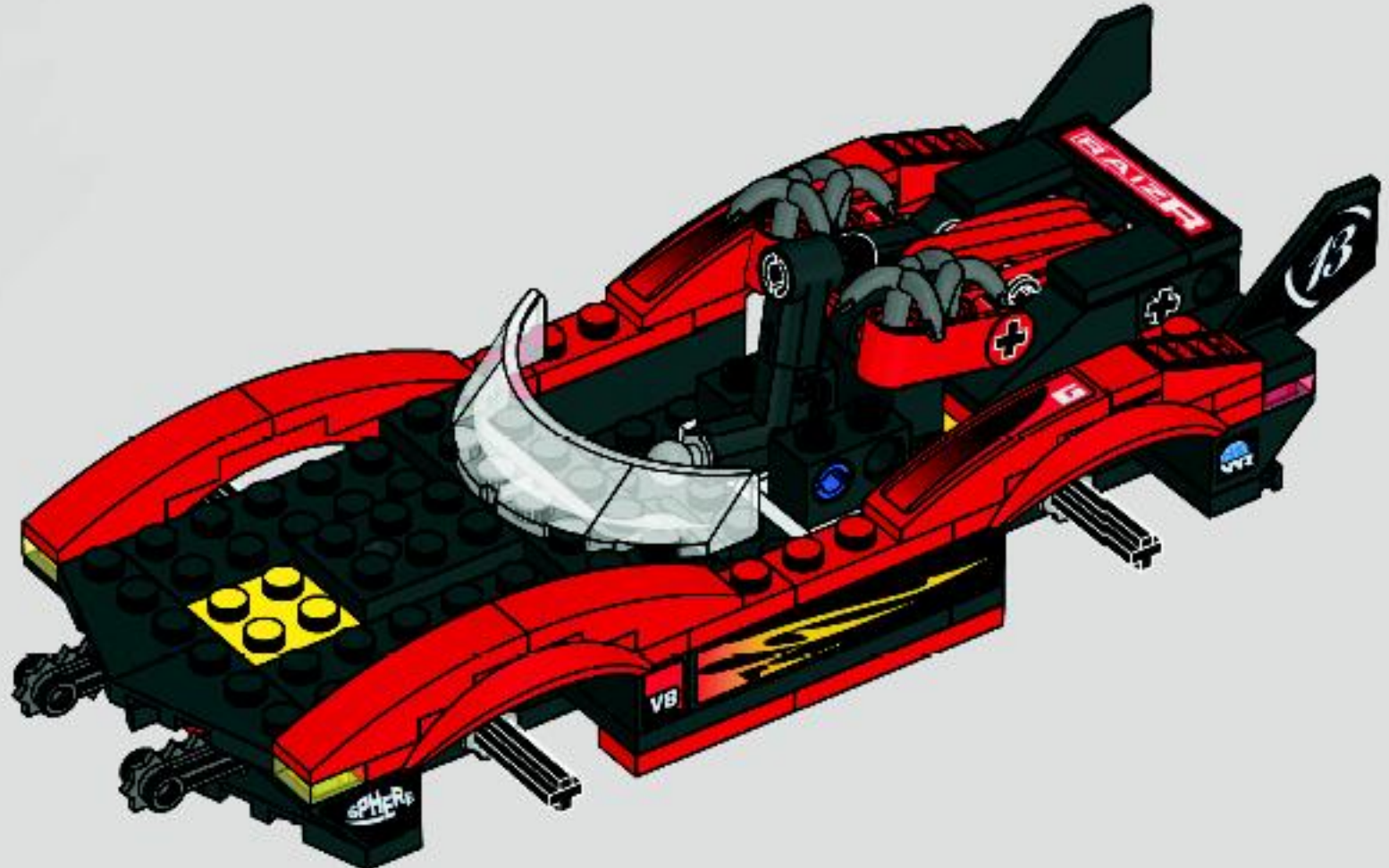



4x

36

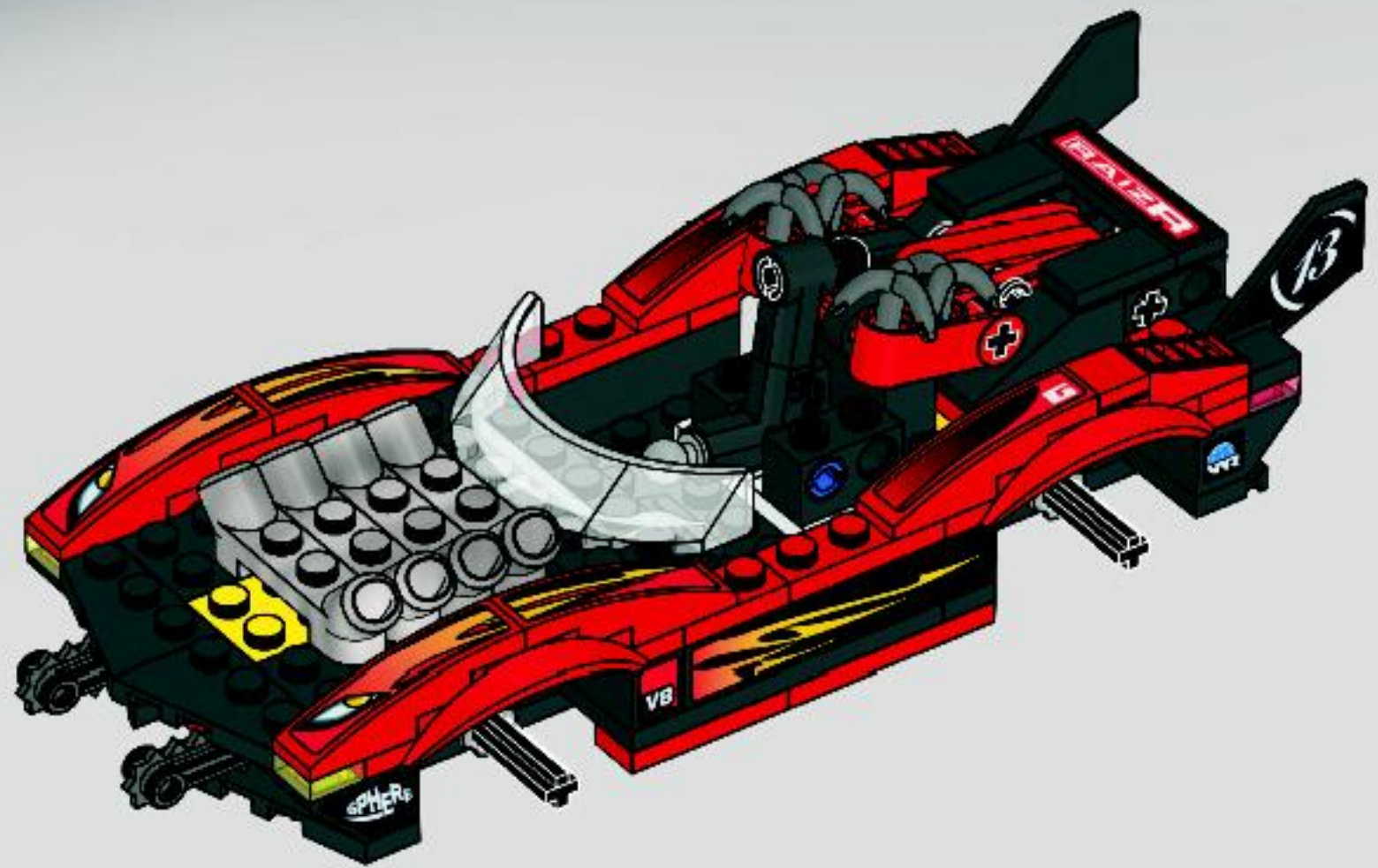

2x



1x

37

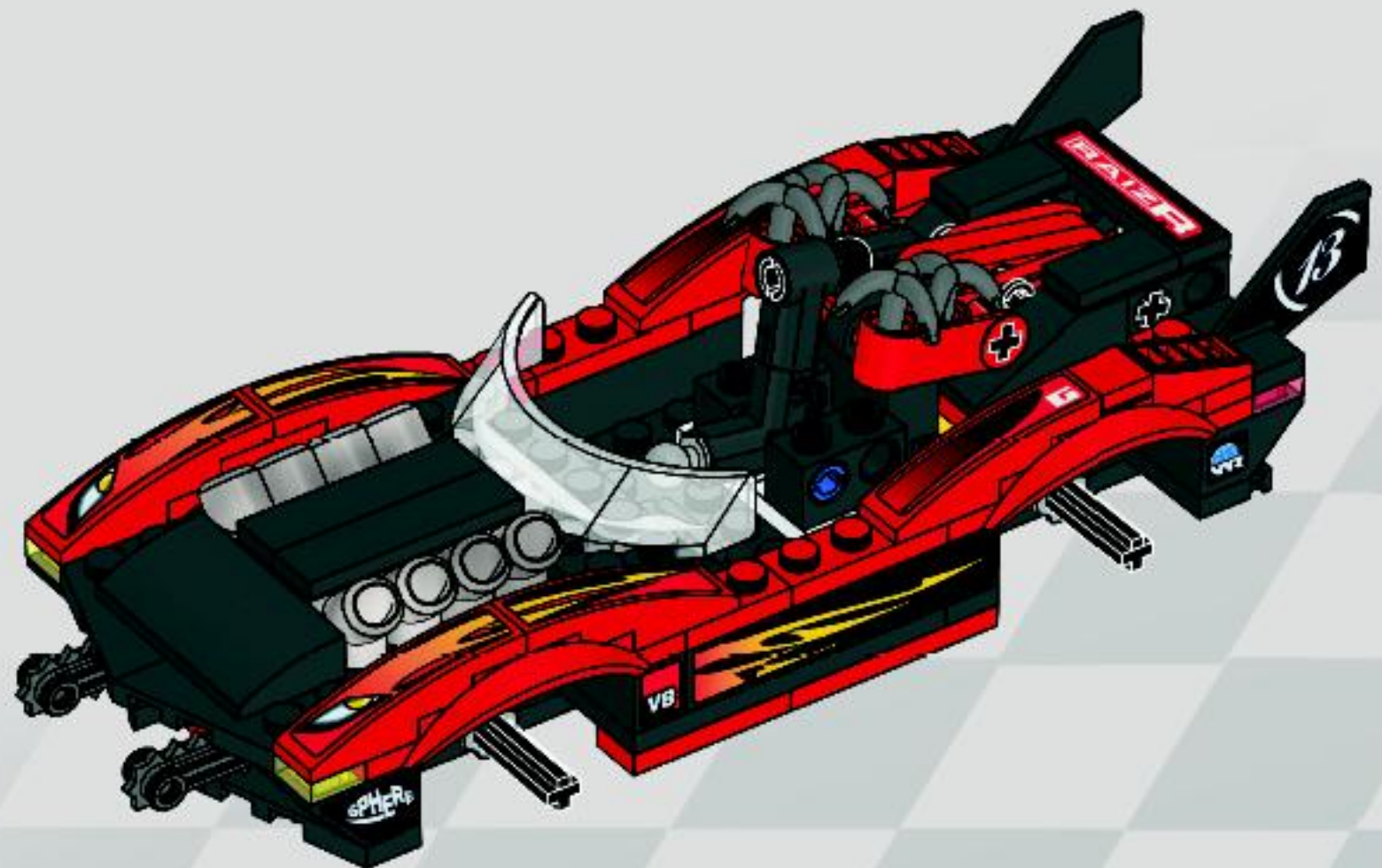



4x



4x



4x

38

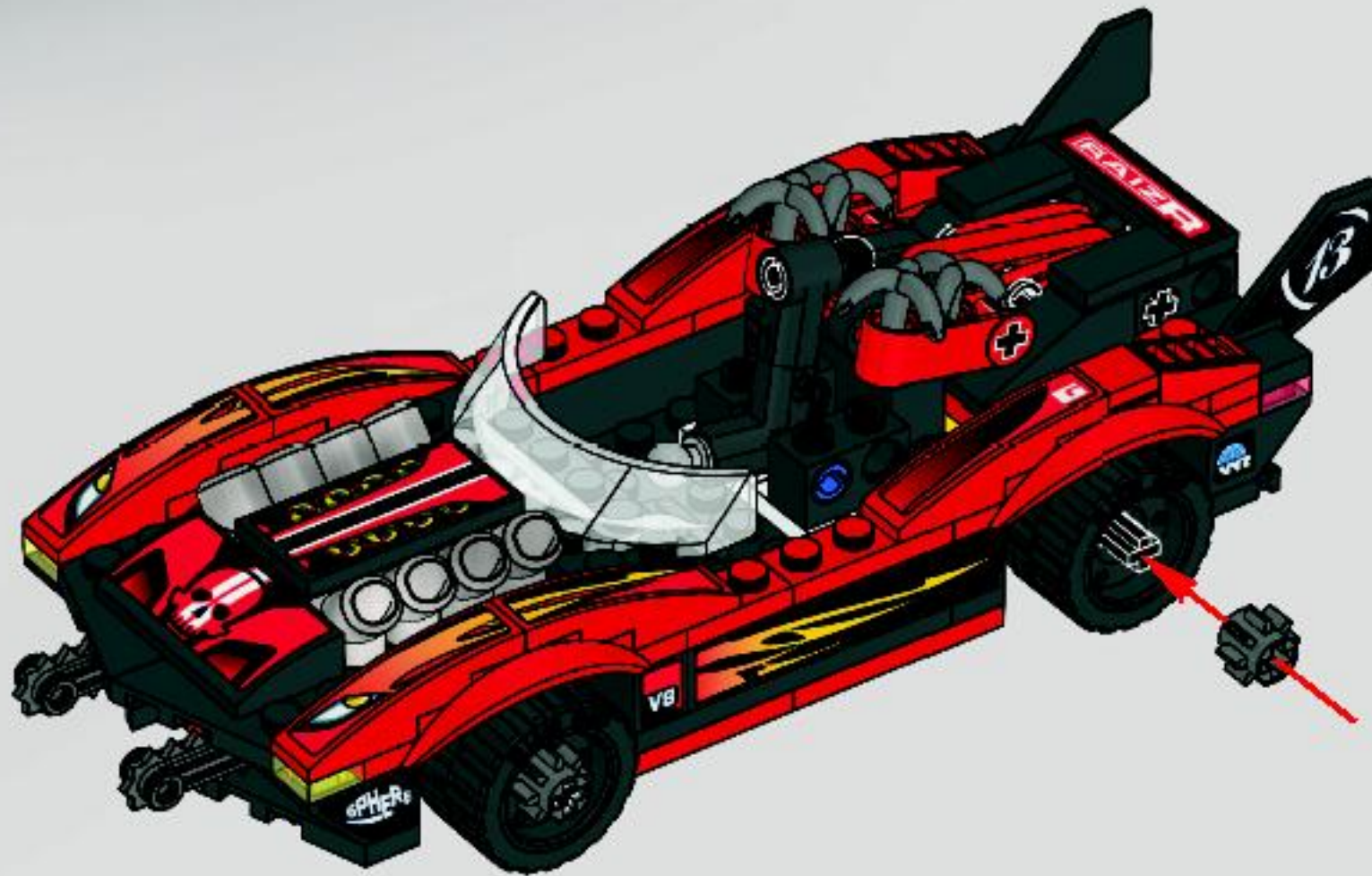

39





World Racers



LEGO 3

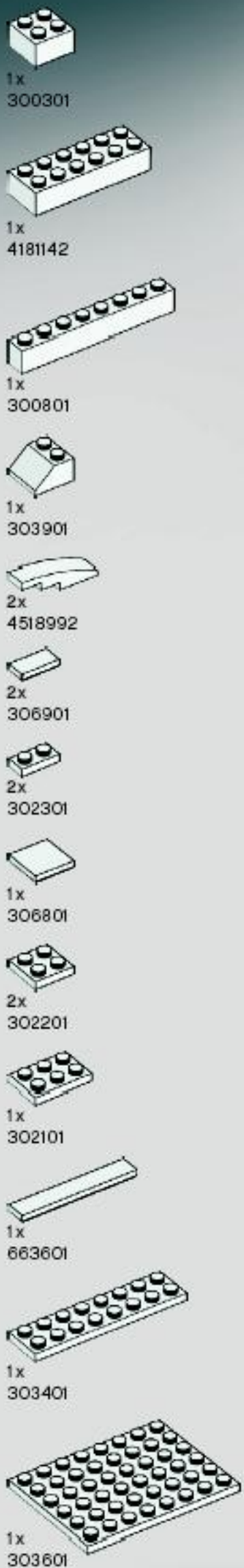

Customer Service
Kundenservice
Service Consommateurs
Servicio Al Consumidor
www.lego.com/service or dial
 : 00800 5346 5555
: 1-800-422-5346



FREE! GRATIS! GRATUIT!



club MAGAZINE™

www.LEGOclub.com



00800 5346 5555*

1-866-534-6258 • 1-877-518-5346
US & Canada only Canada seulement



VISIT THE WORLD'S
BIGGEST LEGO® SHOP!

www.LEGOshop.com

* Free phone. Mobile charges may apply. * Numéro sans frais. Des frais peuvent s'appliquer avec les téléphones cellulaires. * Gebruiksvrij. Kosten bij Aanspreken van Mobiliteit kan binnenkomen.
* Gratis telefonnummer vooP vaste lijn. * Debet ett gratis nummer, när du ringer från mobiltelefon. * Det är gratis, när du ringer från en fast telefon.



WIN!

Go to www.nielsen.com/LEGO to fill out a survey for a chance to win a cool LEGO® Product.

No purchase necessary.

Open to all residents where not prohibited.



www.nielsen.com/LEGO

GEWINNE! WIN!

Nimm an der Umfrage auf www.nielsen.com/LEGO teil und hab die Chance ein cooles LEGO® Produkt zu gewinnen!

Die Teilnahme am Gewinnspiel führt zu keinerlei Kaufverpflichtungen. Teilnahme in allen nicht ausgeschlossenen Ländern möglich.

Ga naar www.nielsen.com/LEGO, vul een enquêteformulier in en maak kans op een cool LEGO® product.

Geen aankoopverplichting. Iedereen mag deelnemen, uitgezonderd ingezetenden van landen waar een enquêteverbod geldt.

GAGNE! 当てよう!

Visite www.nielsen.com/LEGO pour répondre à un questionnaire et avoir une chance de gagner un produit LEGO® très cool!

Aucune obligation d'achat. Ouvert à tous les résidents des pays autorisés.

www.nielsen.com/LEGOにアクセスして、アンケートにご記入ください。当選者にはレゴ製品を差し上げます。

お買い上げの必要はありません。

禁止されていない限り、すべての皆様にご利用いただけます。