

CARING FOR YOUR WATER HEATER



Water Heater Inspections

Venting System

(Direct Vent Only)

The venting system should be inspected periodically to ensure all of the vent sections are secure and airtight. Qualified service personnel are familiar with vent system inspections.

⚠ WARNING: Do not operate the water heater if the vent system shows signs of leaking exhaust. Leaking exhaust could lead to death, personal injury, and/or product failure.

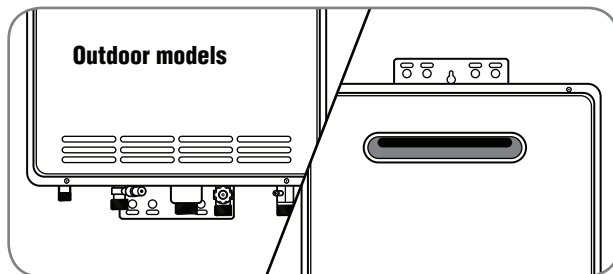

For outdoor models, check the air intake and vent outlet for blockage and/or debris.

Condensate Collector

⚠ CAUTIONS:

- Condensate is known to be acidic; refer to federal, state (provincial), and local codes for proper handling and discharge methods.
- Do not operate without the condensate collector drain connected and routed to a proper drain that can handle corrosive condensate. This could cause the system to malfunction or fail.

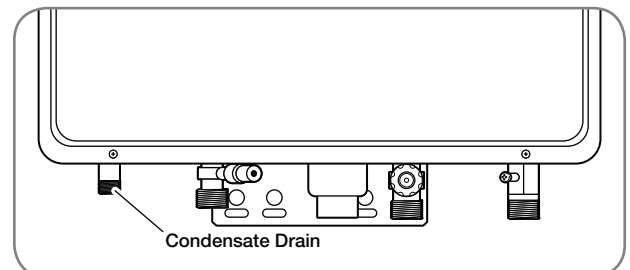
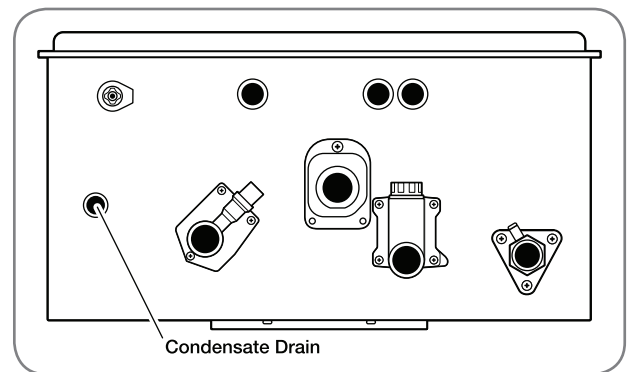

On a regular basis, inspect the condensate drain line to ensure the condensate is draining properly.

The condensate coming from the water heater is known to be acidic. The heater features a built-in condensate neutralizer that uses CaCO_3 (calcium carbonate) in rock form as a medium.

⚠ DANGER: Shock Hazard – Make sure the electrical power to the water heater is off before removing protective cover. Electric shock will cause death or serious personal injury.

Periodically check the medium visually to ensure that it is not depleted and refill accordingly. It is recommended that you contact a qualified service technician to perform the work.

CARING FOR YOUR WATER HEATER



Water Heater Inspections (cont.)

Burner

It is recommended the burner be annually inspected by a qualified service technician.

⚠ DANGER: Shock Hazard – Removing the front cover panel exposes you to live electricity. Electric shock will cause death or serious personal injury.

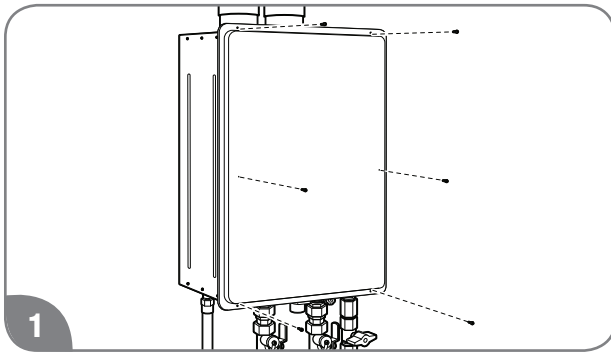

Remove 6 screws and the unit cover panel.

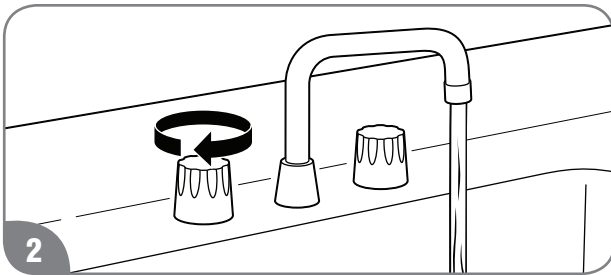

Turn on a hot water faucet.

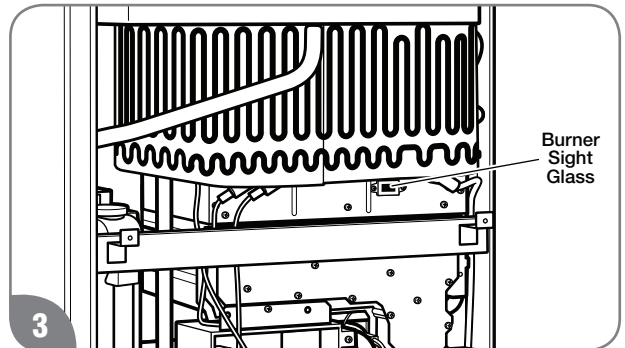

While the water heater is operating, inspect the main burner flames through the burner sight glass. The flames should be blue when the main burner is firing.

NOTICE: If the flames are not blue or you observe unusual burner operation, shut off the water heater and contact a qualified service technician.

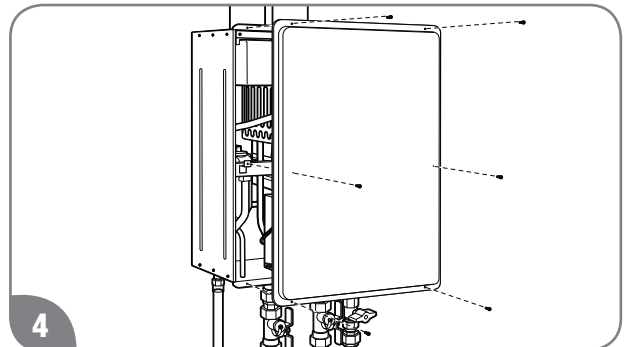

Turn off the hot water faucet and reinstall the unit cover panel.

CARING FOR YOUR WATER HEATER



Care and Cleaning

⚠️ DANGER: Shock Hazard – Make certain power to the water heater is OFF before removing protective cover for any reason. Electric shock will cause death or serious personal injury.

⚠️ WARNING: Combustible materials, such as clothing, cleaning materials, or flammable liquids, must not be placed against or next to the water heater. Fire or explosion can occur causing death, personal injury, and/or product damage.

All care and cleaning to and around the water heater should only be performed with the water heater turned off and the electrical power supply disconnected.

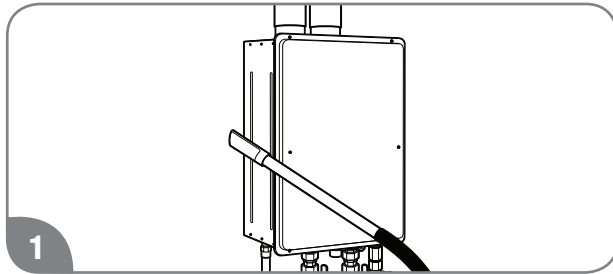

1 Vacuum around the water heater to remove any dust, dirt, and/or lint buildup.

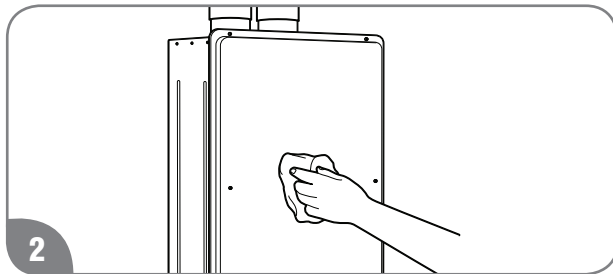

2 Clean the water heater and the remote control with a damp soft cloth and mild detergent. Gently wipe and completely dry all surfaces.

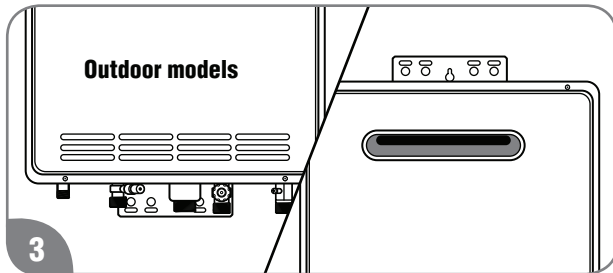

3 Check the air intake and vent outlet for blockage and/or debris.

NOTICE: The air intake requires a minimum of 12 in. (30 cm) of clearance between the air intake opening and any obstruction.

Clean the water filter monthly, as described below.

Water Filter Cleaning

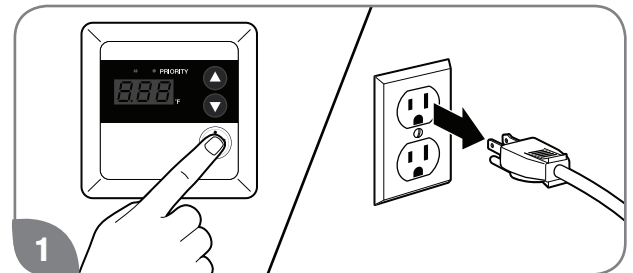

1 Turn off the water heater and disconnect the electrical power supply.

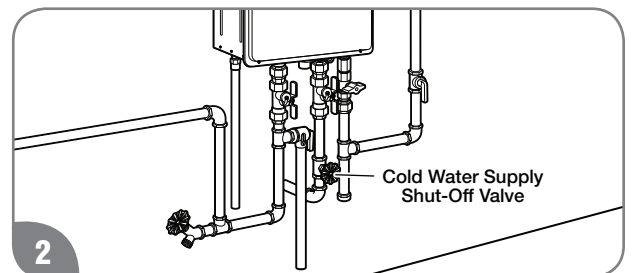

2 Turn off the water supply to the water heater.

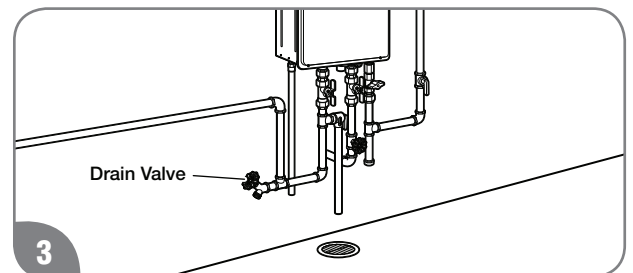

3 Drain the water heater. See page 20.

CARING FOR YOUR WATER HEATER



Care and Cleaning (cont.)

⚠ CAUTION: Do not tap or force the filter during removal. This can deform and/or damage the filter.

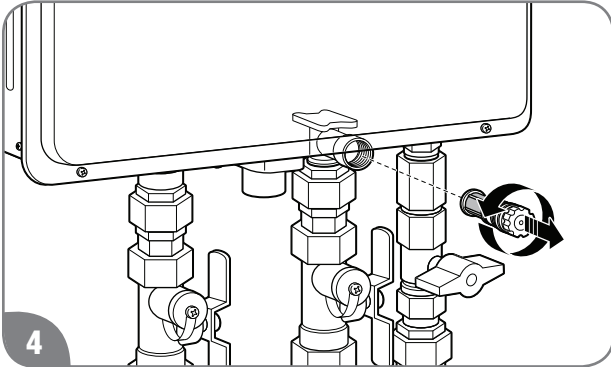

Unscrew the water filter from the base of the cold water inlet line and carefully slide it out of the line.

⚠ CAUTION: Do not overtighten the water filter. Overtightening can deform and/or damage the filter.

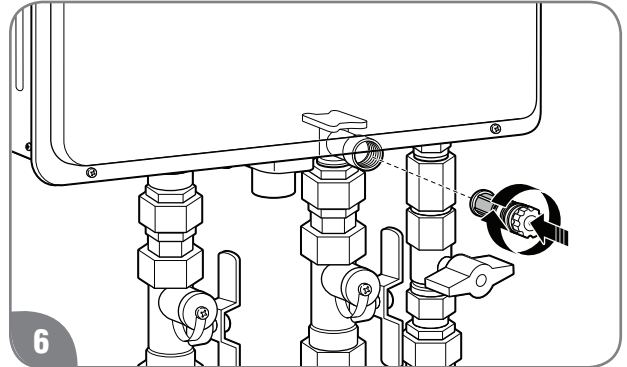

Replace the filter in the cold water inlet line and tighten until it is snug.

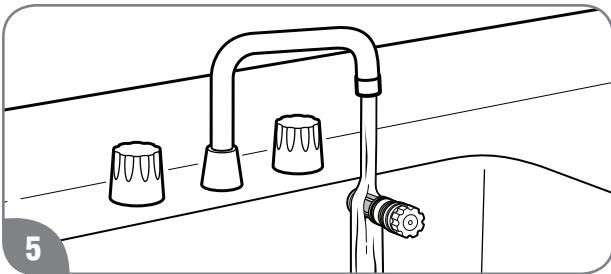

Clean the water filter under running water. To remove severe sediment and dirt, use a soft brush.

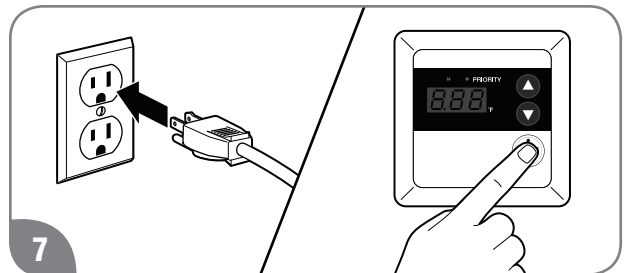

Turn on the water supply, reconnect the electrical supply, and turn on the water heater.

CARING FOR YOUR WATER HEATER



Preventive Maintenance

⚠️ WARNING: Failure to perform routine preventive maintenance can prevent the water heater from operating properly. Improper operation can cause carbon monoxide dangers, excessive water temperatures, and other potentially hazardous conditions resulting in death, personal injury, and/or product damage.

Properly maintaining your water heater will ensure dependable, trouble-free service.

User Preventive Maintenance

Establish and follow a routine preventive maintenance program. The following suggested items should be included in your program.



- The user shall check and clean the water filter monthly. See “Water Filter Cleaning” on page 17.

⚠️ WARNING: Hot water is released during manual operation of the relief valve. Make sure all people and animals are clear from the area before performing this check to prevent death, personal injury, and/or property damage from hot drain water.

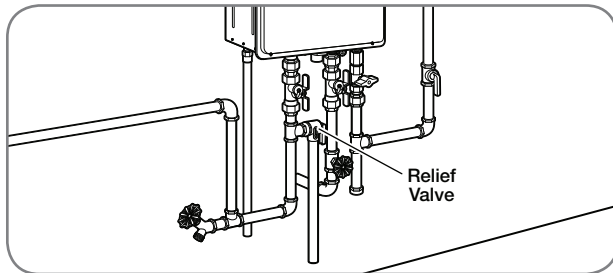

- The user shall check the operation of the pressure relief valve annually. Lifting the lever handle on the pressure-relief valve opens the valve to flush hot water through the discharge line to the drain. After several gallons have drained, release the lever handle to close the valve and stop draining.

NOTICE: If the pressure relief valve on the hot water heater discharges periodically, this may indicate a problem in the water system. Contact the water supplier or a plumbing contractor to correct the problem. **DO NOT** plug the relief valve outlet.

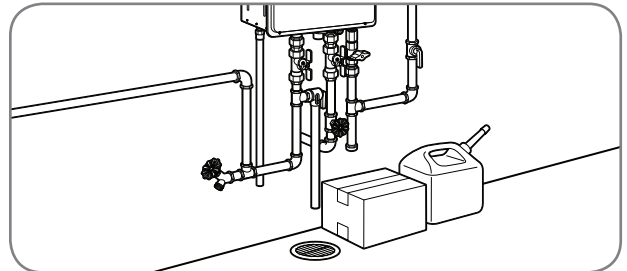

- Inspect and keep the area around the water heater clear and free of flammable materials, such as gasoline and other flammable vapors and liquids.
- Visually inspect the water heater for damage and/or denting. If present, contact a service personnel to verify proper operation.
- Check for abnormal sound during normal operation (e.g., hissing or banging noises). Contact a qualified service technician or plumbing contractor.
- Check all gas and water pipes for leaks. See page 55.

NOTICES:

- **DO NOT** operate the water heater if you feel something is wrong with the unit.
- **DO NOT** allow children to operate or handle the unit.
- After inspections, maintenance, and/or cleaning, ensure proper operation by turning on a hot water faucet.

Professional Preventive Maintenance

It is recommended that a periodic inspection of the water heater burner, relief valve, air intake filter, water filter, and venting system be made by a qualified service technician.

CARING FOR YOUR WATER HEATER



Draining the Water Heater

⚠ WARNING: Failure to follow these draining instructions can cause serious personal injury from scalding and/or product damage.

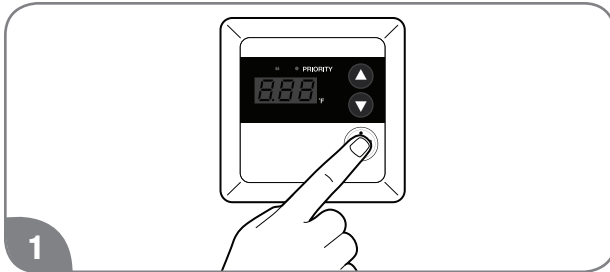

1 Turn off the water heater by pressing the **POWER ON/OFF** button on the control panel.

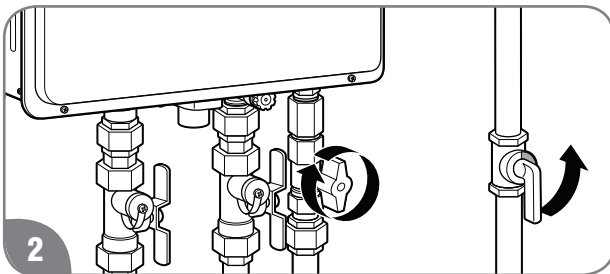

2 Close the gas shut-off valve(s).

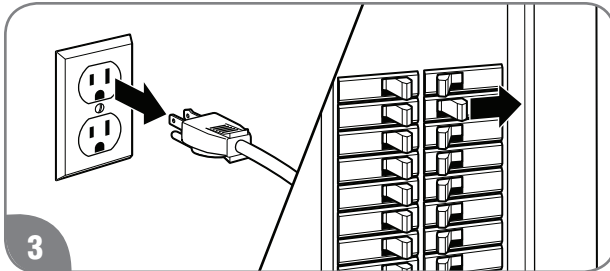

3 At least 10 seconds after Step 1, unplug the water heater or disconnect the power supply at the circuit breaker box.

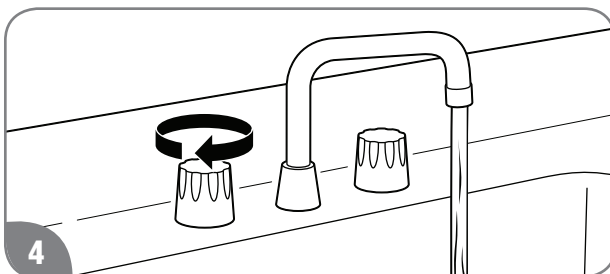

4 Open all hot water faucets. Run the water until it is **COLD**; then shut off the faucet.

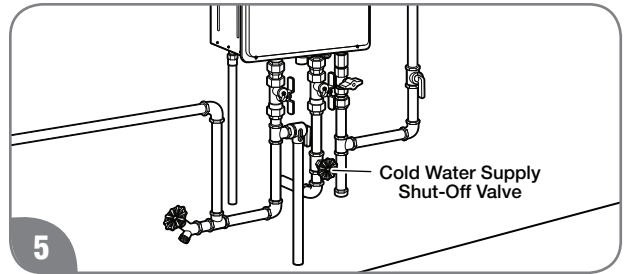

5 Close the water shut-off valve.

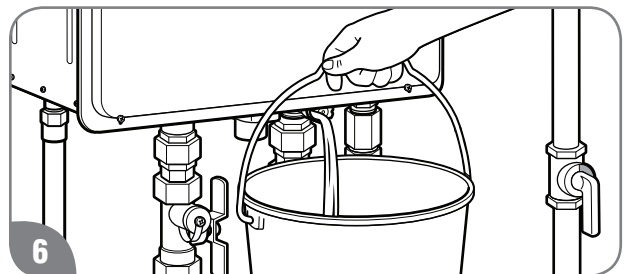

6 Using a suitable container to catch the water, remove the water filter from the base of the cold water inlet line.

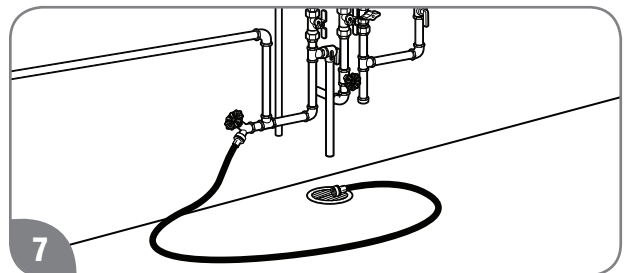

7 Connect a garden hose to the drain valve in the hot water outlet line and place the other end in a suitable drain. Open the drain valve until all the water has drained from the water heater. Leave water heater as is until placed back in service.

CARING FOR YOUR WATER HEATER

⚠ CAUTION: Even when drained properly, a small amount of water will remain in the water heater. In cold weather conditions, this water can freeze. If this happens, allow the defrost protection on the water heater at least 30 minutes to melt the frozen water. The water heater will not work properly until this water is thawed.

To put the water heater back in service:

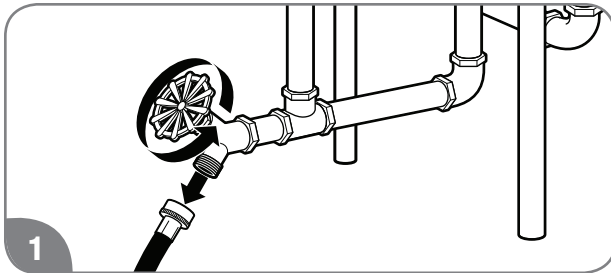

1 Disconnect drain hose. Make sure the drain valve is closed.

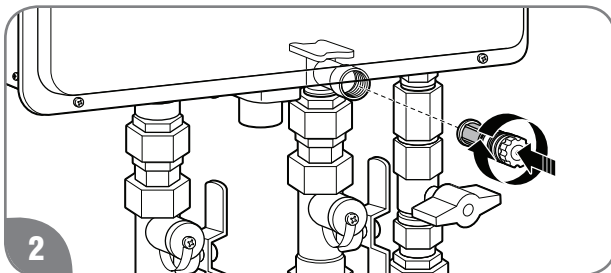

2 Reinstall the water filter in the base of the cold water inlet line.

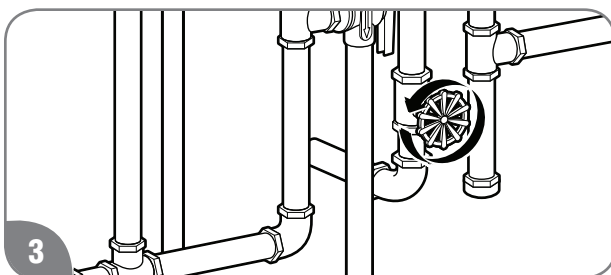

3 Open the water shut-off valve.

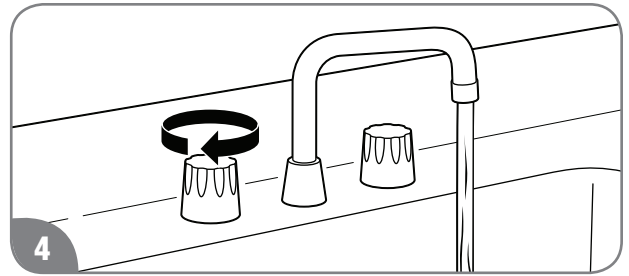

4 Open all hot water faucets and let run until all air has been purged from the lines.

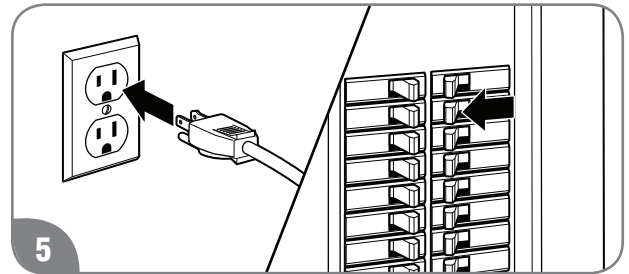

5 Plug in the power cord or reconnect the power supply at the circuit breaker box.

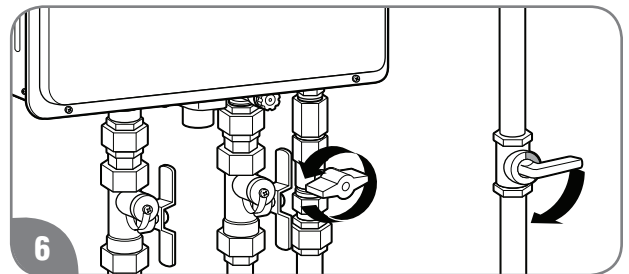

6 Open the gas shut-off valve(s).

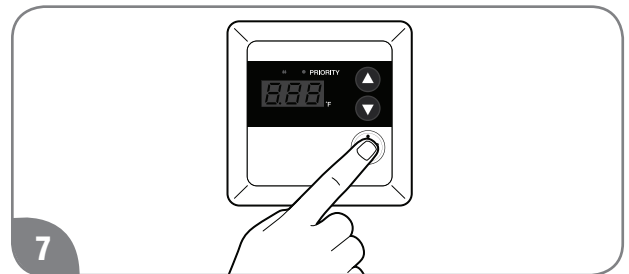

7 Press the POWER ON/OFF button on the control panel to restart the unit.

CARING FOR YOUR WATER HEATER



Draining the Water Heater (cont.)

Standard Drain Method

Service isolator valve kits may be purchased from the manufacturer, distributor, or place of purchase. The kits include two full-port isolation valves to be used in the inlet and outlet water lines. These kits provide a means for full diagnostic testing and ease of system flushing.

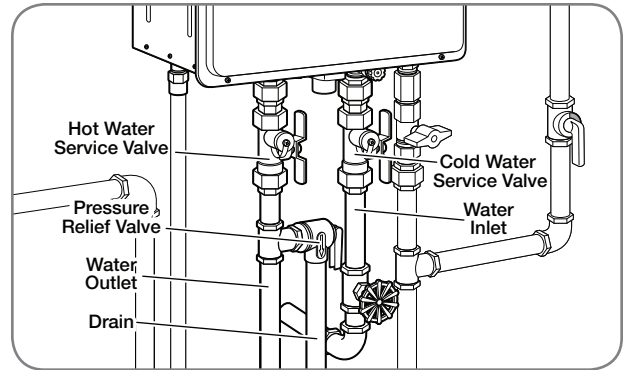

Freeze Protection

⚠️ WARNING: Failure to drain the water heater can cause serious personal injury from scalding and/or product damage.

Whenever the water heater may be exposed to freezing conditions, make sure to completely drain the water from the unit. See page 20.

Freezing conditions come from the ventilation system on direct-vent models and from exposure to cold air on outdoor models.

All of these water heaters are equipped with a freeze protection electric heater. This heater prevents freezing inside the water heater down to an ambient temperature of approximately -30°F (-34°C). These temperatures are all based on temperatures without wind.

The heater only protects the internal components of the water heater.

NOTICE: Unplugging or disconnecting the power supply to the water heater will also disconnect the power to the heater.

External piping and valves require additional freeze protection. One method is to wrap insulation around the piping and valves.

Another method is to turn on a hot water faucet and leave a small amount of water running at a faucet. This will protect the water heater, piping, and valves from freezing.

Running Water Freeze Protection

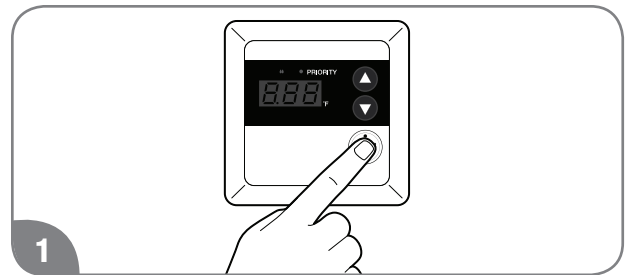

Turn off the water heater by pressing the POWER ON/OFF button on the control panel.

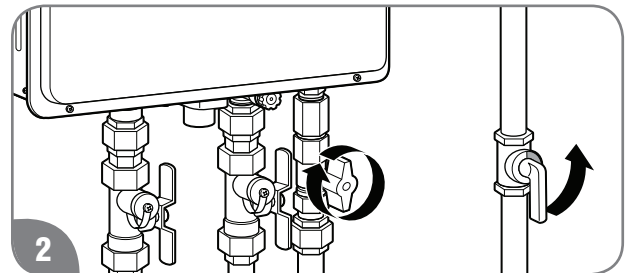

Close the gas shut-off valve(s).

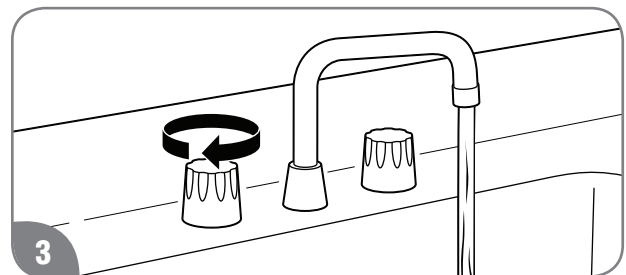

Open a hot water faucet slightly until the water stream is approximately 1/8 in. (0.3 cm). Be sure to check the flow periodically.

CARING FOR YOUR WATER HEATER



Vacation and Extended Shutdown

⚠️ WARNING: Failure to drain the water heater can cause serious personal injury from scalding and/or product damage.

If the water heater is to remain idle for an extended period of time, the power and water to the heater should be turned off.

The water heater and piping should be drained if they might be subjected to freezing temperatures. See “Freeze Protection” section on page 22.

After an extended shutdown, the water heater’s operation and controls should be checked by a qualified service technician.



Troubleshooting Chart

The information in the following troubleshooting chart may help you diagnose and/or fix a problem you may be experiencing. Please review this chart before calling for service assistance.

⚠️ DANGER: Shock Hazard – Make certain power to the water heater is OFF before removing protective cover for any reason. Electric shock will cause death or serious personal injury.

⚠️ WARNING: For Your Safety, DO NOT attempt repair of electrical wiring, gas piping remote control, burners, vent connectors, or other safety devices. Refer repairs to a qualified service technician.

Problem	Possible Cause	Solution
	1. Unit is not ON.	1. Turn on the unit by pressing the POWER ON/OFF button.
	2. Water shut-off valve is not completely opened.	2. Check shut-off valve and open completely.
	3. Hot water faucet is not completely opened.	3. Open hot water faucet completely. (The main burner goes off when incoming water volume is inadequate.)
	4. Water piping is frozen.	4. Allow piping to thaw.
	5. Electrical power is disconnected or water supply is shut off.	5a. Plug in the power cord or reconnect the power supply at the circuit breaker box. 5b. Completely open the water supply valve. (Inadequate water volume will cause the main burner to turn off.)
	6. The temperature may be set too low.	6. Increase the temperature setting.
	7. Mixing valve malfunctions (if applicable).	7. Check and replace the mixing valve.
	8. Error code displayed on the remote control.	8. See “Service Error Code Chart” on page 26. If required, contact a qualified service technician.
	9. Not enough water demand.	9. Increase the hot water flow at the faucet.
	10. Water filter is clogged or dirty.	10. Clean the water filter. (See page 17.)
	11. Fixture aerator is clogged or dirty.	11. Clean the aerator.
	12. Scale buildup in the heat exchanger.	12. Check for error code. If required, contact a qualified service technician.
	13. Hot and cold water lines reversed.	13. Reverse the water lines.

CARING FOR YOUR WATER HEATER

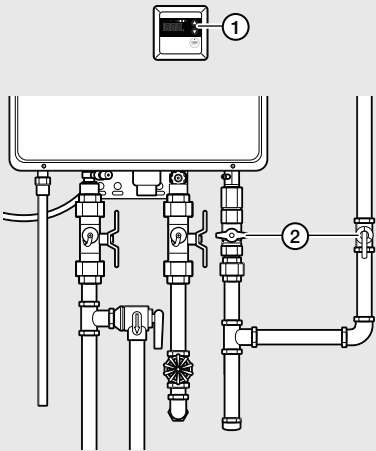
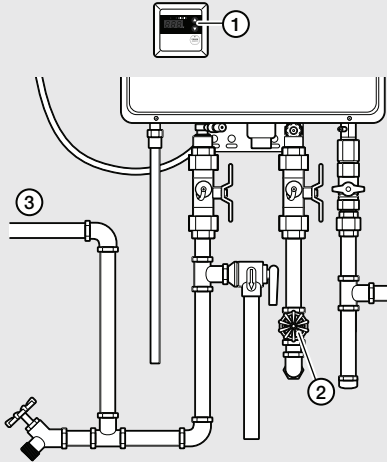

Troubleshooting Chart (cont.)

Problem	Possible Cause	Solution
Water not hot enough. 	1. The temperature may be set too low.	1. Increase the temperature setting at the remote control.
	2. The gas valve is not completely opened.	2. Check and completely open the gas valve.
	3. Gas supply pressure is low.	3. Contact your gas utility company or gas contractor to verify the gas meter and gas piping size.
	4. Bleed-over in one of the hot water fixtures.	4. Contact a dealer or a qualified service technician.
Water too hot. 	1. Temperature is set too high.	1. Decrease the temperature setting at the remote control.
	2. Water shut-off valve is not completely opened.	2. Check and completely open the water shut-off valve.
	3. Small amount of water has been heated.	3. Increase the hot water flow at the faucet to allow more water to flow through the water heater.
Fan continues to rotate after the hot water faucet is closed.	The post-purge cycle clears flue gases.	Normal operation.

CARING FOR YOUR WATER HEATER



Service Error Code Chart

Your water heater has an electronic diagnostic system built into it. When the water heater finds a problem, it displays an error code in the LED display on the remote control. The following chart lists the error codes along with their possible problem and solution. Using this chart may help you diagnose and/or fix a problem you may be experiencing. Please refer to this chart before calling for service assistance.

⚠ DANGER: Shock Hazard – Make certain power to the water heater is OFF before removing protective cover for any reason. Electric shock will cause death or serious personal injury.

⚠ WARNING: For Your Safety, DO NOT attempt repair of electrical wiring, gas piping, remote control, burners, vent connectors, or other safety devices. Refer repairs to a qualified service technician.

When an error code is displayed:

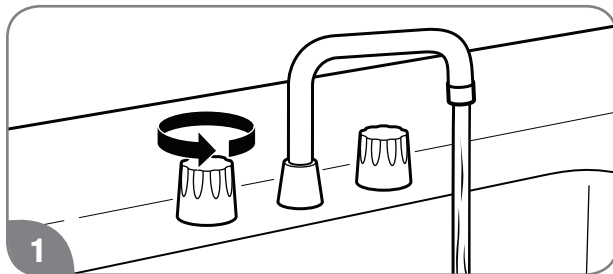

Turn off all the hot water faucets.

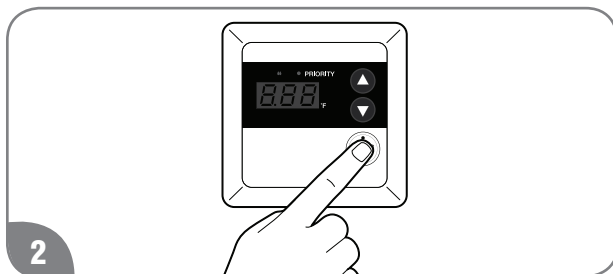

Turn off the water heater by pressing the POWER ON/OFF button on the remote control.

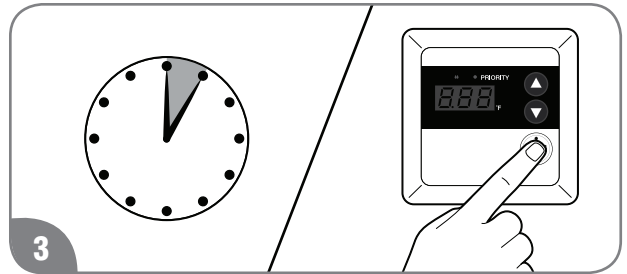

Wait about 5 minutes; then restart the water heater by pressing the POWER ON/OFF button.

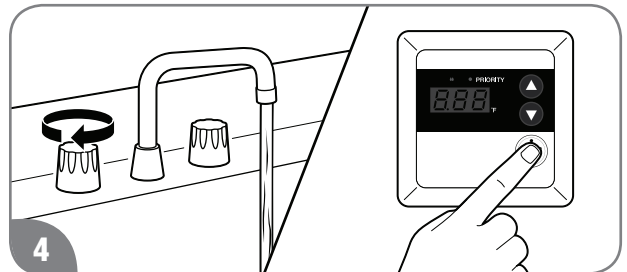

Turn on a hot water faucet and recheck the remote control display.

If the error code remains in the display:

1. Turn off the hot water faucet.
2. Turn off the water heater.
3. Follow the error code chart information.
4. Restart the water heater, turn on a hot water faucet, and recheck the remote control display.

If the error code is still shown:

1. Turn off the hot water faucet.
2. Turn off the water heater.
3. Make note of the displayed error code and call for service assistance. See "Call for Assistance" section on page 26.

NOTICE: If the displayed error code is not listed in the chart, immediately turn off the water heater and call for service assistance.

CARING FOR YOUR WATER HEATER



Service Error Code Chart (cont.)

Error Code	Possible Cause	Solution
1L	Water heater has buildup of lime deposits.	Contact a dealer or qualified service technician.
05	Air intake or vent exhaust opening may be blocked.	Remove any blockage. (Air intake requires 12 in. [30 cm] of clearance.)
	The vent pipes on the vent termination may not be connected properly.	Contact a dealer or qualified service technician.
11	The gas shut-off valve is not fully opened.	Check shut-off valve and open completely.
12	Gas service has been interrupted.	Contact your gas utility company.
	LP gas is running low (LP models only).	Refill or replace your LP gas container.
13	If this code is still displayed after taking the numbered steps above.	Contact a dealer or qualified service technician.
14	Water heater is overheating.	Contact a dealer or qualified service technician.
15	The heat exchanger is too hot.	Check for blockage in the vent. Contact a dealer or qualified service technician.
29	Neutralizer is clogged.	Contact a dealer or qualified service technician.
31	Faulty inlet thermistor.	Contact a dealer or qualified service technician.
33	Faulty outlet thermistor.	Contact a dealer or qualified service technician.
61 or 99	Faulty blower motor.	Contact a dealer or qualified service technician.
65	Faulty water flow solenoid.	Contact a dealer or qualified service technician.
92	The neutralizer needs to be replaced soon.	The unit can be used for a while, but contact a dealer or qualified service technician.
93	The neutralizer must be replaced.	The unit cannot be used until the neutralizer is replaced. Contact a dealer or qualified service technician.
P1	Not enough water flow to operate the unit.	Increase the water flow from the fixtures.

IF YOU NEED SERVICE



Call for Assistance

- All questions, adjustments, repairs, and/or routine maintenance should be directed to your installer, plumbing contractor, or licensed service agent. If your contacts have moved or are not available, please refer to the telephone directory, commercial listings, or local utility company for qualified service assistance.
- If your problem has not been solved to your satisfaction, contact the Manufacturer National Service Department at the following address:
Manufacturer National Service Department
1241 Carwood Court
Montgomery, Alabama 36117
Phone: 1-800-432-8373

When contacting the manufacturer, the following information will be requested:

- Model and serial number. (See page 8 or the ratings plate on the front of the water heater.)
- Address where the water heater is located.
- Name and address of installation contractors (page 8) and all qualified service companies that have worked on the water heater.
- Original installation date. (See page 8.)
- Dates any service or preventive maintenance was performed.
- Details of the persisting problem.
- List of businesses that have tried to fix this problem, along with dates of service.