

Universal Serial Bus Type-C (USB Type-C)

Functional Test Specification

Chapters 4 and 5

Date: March 3, 2024

Revision: 0.91

Copyright © 2016-2024, USB Implementers Forum, Inc.

All rights reserved.

A LICENSE IS HEREBY GRANTED TO REPRODUCE THIS SPECIFICATION FOR INTERNAL USE ONLY. NO OTHER LICENSE, EXPRESS OR IMPLIED, BY ESTOPPEL OR OTHERWISE, IS GRANTED OR INTENDED HEREBY.

USB-IF AND THE AUTHORS OF THIS SPECIFICATION EXPRESSLY DISCLAIM ALL LIABILITY FOR INFRINGEMENT OF INTELLECTUAL PROPERTY RIGHTS, RELATING TO IMPLEMENTATION OF INFORMATION IN THIS SPECIFICATION. USB-IF AND THE AUTHORS OF THIS SPECIFICATION ALSO DO NOT WARRANT OR REPRESENT THAT SUCH IMPLEMENTATION(S) WILL NOT INFRINGE THE INTELLECTUAL PROPERTY RIGHTS OF OTHERS.

THIS SPECIFICATION IS PROVIDED "AS IS" AND WITH NO WARRANTIES, EXPRESS OR IMPLIED, STATUTORY OR OTHERWISE. ALL WARRANTIES ARE EXPRESSLY DISCLAIMED. NO WARRANTY OF MERCHANTABILITY, NO WARRANTY OF NON-INFRINGEMENT, NO WARRANTY OF FITNESS FOR ANY PARTICULAR PURPOSE, AND NO WARRANTY ARISING OUT OF ANY PROPOSAL, SPECIFICATION, OR SAMPLE.

IN NO EVENT WILL USB-IF OR USB-IF MEMBERS BE LIABLE TO ANOTHER FOR THE COST OF PROCURING SUBSTITUTE GOODS OR SERVICES, LOST PROFITS, LOSS OF USE, LOSS OF DATA OR ANY INCIDENTAL, CONSEQUENTIAL, INDIRECT, OR SPECIAL DAMAGES, WHETHER UNDER CONTRACT, TORT, WARRANTY, OR OTHERWISE, ARISING IN ANY WAY OUT OF THE USE OF THIS SPECIFICATION, WHETHER OR NOT SUCH PARTY HAD ADVANCE NOTICE OF THE POSSIBILITY OF SUCH DAMAGES.

Revision History

Revision	Issue Date	Comments
0.5	2/10/15	Initial revision for internal review only.
0.6	2/23/15	First revision for external review
0.6	3/8/15	Updated to reflect USB Type-C Specification Revision 1.1, mostly affecting Connection State Machines. More spec revisions in progress.
0.61	4/10/15	Updated to reflect finalized version of USB Type-C Specification Revision 1.1
0.63	5/13/15	Tests updated to reflect that Vconn can only be checked on PUT_Rs. Test implementation is underway
0.63	5/27/15	CVS block diagram added. Debug Accessory checks added.
0.64	6/17/15	Connection State tests implemented
0.65	7/22/15	Disconnect times are immediate, Vconn is optional
0.66	8/31/15	TDs are headings, TDs are revised per several ECRs
0.67	9/14/15	Update to reflect USB type-C Specification Revision 1.1 changes missed
0.68	10/8/15	Detach timer updates, TD 4.18, 4.31 updates
0.68.1	11/28/15	Requirement update (Product Section), addition to Source-Capable Tests and Sink-Capable Tests sections describing test initialization for PD DRPs with Source/Sink default.
0.7	1/6/16	Update TD Numbering to allow for changes ahead, Try.SNK and Try.SRC connection test placeholders added, various other edits
0.7	1/15/16	Fixed a couple TD Numbering errors
0.71	3/3/16	Updated to tPDDebounce checks out of AttachWait.SNK, tAMETimeout update, various other edits
0.73	6/17/16	Updated test applicability for each TD and included VIF field explanation in testing
0.75	10/18/16	Added Try.SNK and Try.SRC tests (18 new tests) and some updates to DRP tests accordingly
0.76	12/4/16	Misc. timings and inconsistent steps updates
0.77	1/3/18	Vconn 70mW, Attach and Detach timings, Safe state, clarify PD messaging, BC 1.2 current, Audio Accessory checks, Applicability Sections update, attach Ra for applicable tests, DRP attach states
0.78	3/21/18	TD 4.2.1 – Editorial change TD 4.7.3 – Update timers TD 4.8.3 – Updated to include Try.SNK TDs 4.10.1, 4.10.2 – SNK power sub-states update with USB Self and Bus-powered descriptor info VIF field update Type_C_Battery_Powered to Port_Battery_Powered. TD 4.11.2 – Updated to clarify PUT cannot source Rp TD 4.12.2 – Editorial change
0.79	5/28/18	TD 4.2.1, 4.5.1 – Terminations present by 1s TD 4.2.4, 4.6.3 – Update timers TD 4.2.8, 4.11.1 – Applicability updated TD 4.5.4, 4.6.3 – Updated to Attached.SRC Exit ECN TD 4.7.5 – CVS acts as Active Cable 5A capability TD 4.9.4 – Refers to ACCEPT not PS_RDY

		TD 4.10.1, 4.10.2, 4.10.3 – Power check updates TD 4.11.2 – Dead battery clarification
0.81	3/28/2019	TD 4.1.1 – Captive Cable hot plug incorporated TD 4.1.2 – Unpowered CC Voltage test incorporated TD 4.1.1, 4.11.1 –USB 2.0 and USB 3.2 terminations are not present checks TD 4.2.1, 4.5.1, 4.6.5, 4.7.5 – Emulate PD 3.0 and PD 2.0 Active Cable TD 4.2.1, 4.4.8, 4.5.1, 4.6.5, 4.7.5 – Vconn checks and SS terminations timer Various TDs – Timers clarified, current measure timing clarified TD 4.3.4 – Try.SNK tCCTryDebounce TD 4.3.5, 4.10.6 – Alt Mode Exit Mode tested TD 4.4.8 – Unsupported.Accessory user notification check TD 4.5.4, 4.6.3, 4.7.2 – Vbus disconnect check TD 4.9.5 –Alt Mode Controller and no host support check TD 4.10.1 – USB Default Current depends on current data rate clarification TD 4.10.3 – Suspend power clarification TD 4.12.2 – Fix numUFP
0.82	7/8/2019	TD 4.1.2 – Add Port_Battery_Powered is NO to 3 rd applicability item, rework of procedure steps TD 4.2.1, 4.5.1, 4.6.4, 4.7.4 – Add LFPS timing check Source-Capable Tests – add Vconn_Swap for ports that need PR_Swap as part of test setup TD 4.10.1 – Specify enumeration does not configure device TD 4.11.2 – Add prompt for tester to visually check PUT for batteries, update applicability TD 4.3.1, 4.10.6 – Allow device enumeration to wait for PD contract TD 4.10.2 – Add tSinkAdj timing to step 15.j
0.83	10/30/2019	TD 4.1.1 – zSBUTermination tolerance added TD 4.2.1, 4.5.1, 4.6.5, 4.7.5 – Add Host D3 Warm Reset case, zSBUTermination check, terminations timing after Vbus on clarification TD 4.3.1, 4.4.1, 4.5.3, 4.6.1, 4.7.1 – Add zSBUTermination check Various TDs – UFP terminations timing clarified TD 4.10.6 – USB Safe State or USB data update TD 4.12.2 – tAccDetect updated to tCCDebounce, tDetach updated to tCCDebounce, Attached timing added
0.84	4/16/2020	TD 4.12.1 – Prompt updated to include captive plug UFPs TD 4.13.1, 4.13.2, 4.13.3, 4.13.4 – USB4 Enter_USB and Data_Reset tests added
0.85	6/4/2020	Tests section – UFP terminations timing (USB4), CVS terminations TD 4.3.1, 4.4.1 – Vbus regression test TD 4.4.8 – Unsupported.Accessory update TD 4.9.x, 4.10.x – C/P and P/C applicability and steps TD 4.13.1 – Removed old DFP requirement
0.86	7/16/2020	TD 4.13.5 Cable test added Product VIF section field updates and VIF field updates in test applicability and steps Appendix B: XML Results Schema Condition and Verification tags applied to:

		TD 4.1.x TD 4.5.x
0.87	10/7/2020	TD 4.14.x Cable Tests added - includes changes to Intro, Terms, Tests section, TD 4.1.3, TD 4.13.5, TD 4.14.1-5, TD 4.13.1 – Passive Cable TBT compatibility condition fix,
0.88	5/20/2021	PUT Tests – Data verifications clarified, data tags added CPUT Tests – LRD TBT3 Cable specified as Active cable TD 4.1.1 – Removed verification TD.4.1.1.V.1 TD 4.2.1, 4.5.1, 4.6.5, 4.7.5, 4.9.4, 4.10.5, 4.13.1 – USB4 Redriver Cable case added TD 4.11.3 – Added test for captive cable checks TD 4.13.1 – Condition 8 fix, Condition 11 removed TD 4.13.4 – Applicability updated TD 4.13.6 – Cable test for emarker silicon only added Various – tDetach timer updated to tSRCDisconnect
0.89	10/28/2021	Product Test Requirements section added PUT Tests – eSS terms clarification, tester cable emulation details CPUT Tests – Cable Termination field TD 4.2.1, 4.5.1, 4.6.5, 4.7.5 – Captive Cable condition added TD 4.5.4, 4.6.2, 4.7.2 – tDRPHold removed TD 4.11.2 – Source only case fix TD 4.11.3 – Field name, data role correction TD 4.12.2 – Captive Cable support TD 4.13.1 – Conditions table, conditions check fixes TD 4.13.2 – USB4 host updates from base spec TD 4.13.4 – Vconn swap support applicability TD 4.14.4 – Cable latency base spec update
0.9	2/23/2023	Definitions – Vbus ON Product VIF – Editorial field name updates PUT Tests – eSS terms timing updated for tUSB4Timeout Electrical section, TD 4.2.1, 4.3.1, 4.4.1, 4.5.1, 4.5.3, 4.6.1, 4.6.5, 4.7.1, 4.7.5 – zSBUTermination tester example and tolerance removal TD 4.4.4 – Updates based on Accessory supported TD 4.5.4, 4.6.3, 4.7.2 – tOnePortToggleConnect incorporated, regression test editorial update TD 4.5.5 – Verification Steps TD 4.10.1,4.10.2 – VIF field name updates TD 4.10.1 – Conditions introduced TD 4.10.6 – VIF field Hub_Billboard_DSPort_Num incorporated TD 4.13.1 – Conditions and table changes and additions, TBT3 legacy cable updated TD 4.13.2 – Many steps conditional on whether UFP data is supported TD 4.13.3 – tEnterUSB timing, PD contract power TD 4.13.4 – tEnterUSB timing, condition added when Data speed changes after Data Reset
0.91	3/3/2024	Source-Capable and Sink-Capable test sections reference not found fixed. TD 4.9.2 – Reset for PD checks TD 4.9.4 – Vconn_Swap verifications added TD 4.10.6 – Add check for no Alt Modes, editorial step

		change, incorporate VIF fields for Alt Mode entry TD 4.13.3 – Discover ID req fixed TD 4.13.4 – Editorial step verification tag update to reflect correct test
--	--	--

Significant Contributors:

Amanda Hosler	Specwerkz LLC
Abel Astley	Ellisys Corporation
Mario Pasquali	Ellisys Corporation
Balaji Baskaran	Granite River Labs
BalaMurugan Manialagan	Granite River Labs
Pranav Tipnis	Intel Corporation
Tyler Joe	Teledyne LeCroy Corporation
Mike Micheletti	Teledyne LeCroy Corporation

Contents

Introduction.....	8
Terminology.....	8
Assertions.....	9
Test Requirements	44
Hardware.....	44
Electrical	45
Timing.....	45
Product VIF.....	46
Tests.....	51
PUT Tests	51
CPUT Tests.....	54
Connection Tests.....	55
Source Tests	58
Sink Tests.....	63
SNKAS Tests	67
DRP Tests	74
Try.SRC DRP Tests	81
Try.SNK DRP Tests.....	88
All DRPs Tests.....	95
Source-Capable Tests.....	97
Sink-Capable Tests	103
Miscellaneous Tests	113
Hub Ports Tests.....	117
USB4 PD Tests	119
Cable Tests.....	131
Appendix A: TD Number Update.....	138
Appendix B: USB-IF Results Schema.....	139

Introduction

These tests check that USB Type-C cables and connectors are compliant to the USB Type-C Chapters 4, 5, 6 and Appendix E asserts and functional requirements.

There are a variety of different operational approaches for a USB Type-C connector. For example, a basic mouse will never host or source current to another device, so its USB Type-C connector only needs to support a UFP and Sink role. A smartphone may host a mouse or keyboard, and may be a device hosted by a USB Charger. The USB Type-C connector for the phone in this example needs to support both UFP and DFP, and both Source and Sink roles. A glance at the USB Type-C configuration matrix in Spec Table 4-23 gives an idea of the available USB Type-C Product Types covered in this spec.

Due to the variety of connections to be made with USB Type-C connectors, there is a variety of electrical and timing requirements that constrain their interaction and lead to functional connections.

Cables vary in implementation less than ports, and are all subject to the same state machine. USB4 support, Alternate Mode support, USB 3.2 Ustate and Suspend requirements add some variety of implementation and testing requirements.

Port and Cable tests are groups by USB Type-C Connection State implementation, Source/Sink Capability, whether the port belongs to a Hub, whether the Port or Cable supports USB4, and Cable capabilities.

Terminology

The following table describes the terms used in this document.

BC	Background Check – Used in the assertions table to indicate an assertion is implicitly verified as a function of running a Type-C Functional Test.
CabCon	USB Type-C Cable Assembly and Connector Tests – Used in the assertions table to indicate an assertion is verified by the USB Type-C Cable Assembly and Connector Test Suite.
CPUT	Cable Plugs Under Test – The USB Type-C cable plugs associated with a passive or short active cable tested by the tests defined in this document.
CVS	USB Type-C Connection Verification System. Test equipment capable of performing the USB Type-C Functional tests defined in this document
CVSd	The tester responsible for Type-C SNK / Device emulation for CPUT tests
CVSh	The tester responsible for Type-C SRC / USB Host emulation for CPUT tests. This tester also starts as the Vconn Source.
DFP	Downstream Facing Port – a USB Type-C port that supports the USB 3.1 Link State Machine or USB 2.0 data as a downstream facing port.
DRP	Dual Role Port – A USB Type-C port that supports the USB Type-C Connection State Machines as a DRP. This port is capable of acting as a Source and a Sink.
DUT	Device Under Test – the USB-C product which incorporates the PUT referred to in each Test Definition.
IOP	Interoperability – Used in the assertions table to indicate an assertion is verified by the USB 3.1 Interoperability and Backwards Compatibility Test Suite
NT	Not tested – Used in the assertions table to indicate an assertion is not tested
PD	USB Power Delivery Tests – Used in the assertion table to indicate an assertion is verified by the USB Power Delivery Test Suite.
PUT	Port Under Test – The USB Type-C Connector port that is tested by the tests defined in this

	document.
PUT_C	PUT that is bound to a USB Type-C captive cable or direct attach plug
PUT_R	PUT that is bound to a USB Type-C receptacle.
PUT_V	PUT that is required to or capable of sourcing Vconn.
Sink	USB Type-C port that supports the USB Type-C Connection State Machines as a Sink
SNKAS	Sink with Accessory Support – A USB Type-C port that supports the USB Type-C Connection State Machine as a Sink with Accessory Support.
Source	USB Type-C port that supports the USB Type-C Connection State Machines as a Source
Operator	Person operating the test.
UFP	Upstream Facing Port – A USB Type-C port that supports the USB 3.1 Link State Machine or USB 2.0 data as an upstream facing port.
Vbus ON	Voltage on Vbus entered vSafe5V range after power on or reset event
VIF	Vendor Info File – A USB-IF product certification tool that logs info about the PUT for tracking purposes and so a test vendor knows what tests are applicable.

Assertions

Compliance criteria are provided as a list of assertions that describe specific characteristics or behaviors that must be met. Each assertion provides a reference to the USB 3.1 specification or other documents from which the assertion was derived. In addition, each assertion provides a reference to the specific test description(s) where the assertion is tested.

Each test assertion is formatted as follows:

Assertion #	Test #	Assertion Description
-------------	--------	-----------------------

Assertion#: Unique identifier for each spec requirement. The identifier is in the form USB31_SPEC_SECTION_NUMBER#X, where X is a unique integer for a requirement in that section.

Assertion Description: Specific requirement from the specification

Test #: A label for a specific test description in this specification that tests this requirement. Test # can have one of the following values:

NT This item is not explicitly tested in a test description. Items can be labeled NT for several reasons – including items that are not testable, not important to test for interoperability, or are indirectly tested by other operations performed by the compliance test.

X.X This item is covered by the test described in test description X.X in this specification.

IOP This assertion is verified by the USB 3.1 Interoperability and Backwards Compatibility Test Suite.

BC This assertion is applied as a background check in all test descriptions.

PD This assertion is verified by the USB-IF Power Delivery Test Suite.

CabCon This assertion is verified by the USB Type-C Cable Assembly and Connector Test Suite

Test descriptions provide a high level overview of the tests that are performed to check the compliance criteria. The descriptions are provided with enough detail so that a reader can understand what the test does. The descriptions do not describe the actual step-by-step procedure to perform the test.

The following Table presents the USB Type-C Specification Chapter 4 and 5 asserts.

Assertion #	Test Name	Assertion Description
USB Type-C Cable and Connection Specification		
4.3 Side Band Use (SBU)		
4.3#1	4.1	The SBU pins on a port shall either be open circuit or have a weak pull-down to ground no stronger than zSBUTermination.
4.4 Power and Ground		
4.4.1 IR Drop		
4.4.1#1	EPC.2	The maximum allowable cable IR drop for ground shall be 250 mV and for VBUS shall be 500 mV through the cable to the cable's maximum rated VBUS current capacity.
4.4.1#2	EPC.2	When VCONN is being sourced, the IR drop for the ground shall still be met considering any additional VCONN return current.
4.4.2 VBUS		
4.4.2#1	4.2 4.4	The allowable default range for VBUS as measured at the DFP receptacle shall be as defined by the USB 2.0 Specification and USB 3.1 Specification.
4.4.2#2	4.1 4.2 4.4	The Source's USB Type-C receptacle VBUS pin shall remain unpowered and shall limit the capacitance between Vbus and GND as specified in Table 4-2 until a Sink is attached.
4.4.2#3	4.2 4.4	The Source's VBUS pin shall return to the unpowered state when the Sink is detached.
4.4.2#4	4.2	A DRP or DFP or UFP with Accessory Support implementing an Rp pull-up as its method of connection detection shall provide an impedance between VBUS and GND on its receptacle pins as specified in Table 4-2 when not sourcing power on VBUS (i.e., when in states Unattached.SRC or Unattached.Accessory)
4.4.3 VCONN		
4.4.3#1	BC	Initially, VCONN shall be sourced by all USB Type-C receptacles that source Vbus and utilize the SSTX and SSRX pins during specific connection states as described in Section 4.5.2.2.
4.4.3#2	BC	Table 4-5 provides the voltage and power requirements that shall be met for VCONN.
4.4.3#3	BC	Table 4-6 provides the requirements that shall be met for cables that consume VCONN power.

Assertion #	Test Name	Assertion Description
4.4.3#4	CabCon	A cable shall not present more than the equivalent inrush capacitance (10uF) to the VCONN source.
4.4.3#5	Not Testable	The cable shall remove or weaken Ra according to the state diagram behavior in 4.5.2.5.
4.4.3#6	4.14.1	The cable shall reapply Ra according to the state diagram behavior in 4.5.2.5.
4.4.3#7	4.14.1	The cable shall discharge Vconn to below vVconnDischarge on a cable disconnect.
4.4.3#8	4.14.1	The cable shall control Ra at each of its ends independently based on the Vconn on that end.
4.5 Configuration Channel (CC)		
4.5.1 Architectural Overview		
4.5.1.1 USB Data Bus Interface and USB Type-C Plug Flip-ability		
4.5.1.2 Connecting DFPs and UFPs		
4.5.1.2#1	4.1	In the cases where no function results, neither port shall be harmed by this connection.
4.5.1.2#2	4.1	VBUS and VCONN shall not be applied by a Source (host) in a host-host connection.
4.5.1.3.2 UFP Configuration Channel Functional Model		
4.5.1.3.2#1	BC	The Sink shall manage its load to stay within the detected Source current limit.
4.5.2 CC functional and Behavioral Requirements		
4.5.2#1	BC	The plug on a direct connect device or a device with a captive cable shall behave as a plug on a cable that is attached at its other end in normal orientation to a receptacle.
4.5.2#2	BC	Devices with a plug on a direct connection or a captive cable shall apply and sense CC voltage levels on pin A5 only and pin B5 shall have an impedance above zOPEN, unless it is a Powered Accessory, in which case B5 shall have an impedance Ra.
4.5.2.2 Connection State Machine Requirements		
4.5.2.2#1	Not Tested	Entry into any unattached state "when directed from any state" shall not be used to override tDRP toggle.
4.5.2.2.1 Disabled State		
4.5.2.2.1#1	4.1	If the Disabled state is not supported, the port shall be directed to either the Unattached.SNK or Unattached.SRC states after power-on.
4.5.2.2.1.1 Disabled State Requirements		

Assertion #	Test Name	Assertion Description
4.5.2.2.1.1#1	4.1	The port shall not drive VBUS or VCONN, and shall present a high-impedance to ground (above zOPEN) on its CC pins.
4.5.2.2.1.2 Exiting From Disabled State		
4.5.2.2.1.2#1	Not Tested	A Sink shall transition to Unattached.SNK when directed.
4.5.2.2.1.2#2	Not Tested	A Source shall transition to Unattached.SRC when directed.
4.5.2.2.1.2#2	Not Tested	A DRP shall transition to either Unattached.SNK or Unattached.SRC when directed.
4.5.2.2.2 ErrorRecovery State		
4.5.2.2.2#1	Not Tested	If the ErrorRecovery state is not supported, the port shall be directed to the Disabled state if supported. IF the Disabled state is not supported, the port shall be directed to either the Unattached.SNK or Unattached.SRC states.
4.5.2.2.2.1 ErrorRecovery State Requirements		
4.5.2.2.2.1#1	Not Tested	The port shall not drive VBUS or VCONN, and shall present a high-impedance to ground (above zOPEN) on its CC pins.
4.5.2.2.2.2 Exiting from ErrorRecovery State		
4.5.2.2.2.2#1	Not Tested	A Sink shall transition to Unattached.SNK after tErrorRecovery
4.5.2.2.2.2#2	Not Tested	A Source shall transition to Unattached.SRC after tErrorRecovery
4.5.2.2.2.2#2	Not Tested	A DRP shall transition to Unattached.SNK or Unattached.SRC after tErrorRecovery
4.5.2.2.3 Unattached.SNK State		
4.5.2.2.3#1	4.37	A port with a dead battery shall enter this state while unpowered.
4.5.2.2.3.1 Unattached.SNK State Requirements		
4.5.2.2.3.1#1	4.8 4.9	The port shall not drive VBUS or VCONN
4.5.2.2.3.1#2	4.8 4.9	Both CC pins shall be independently terminated to ground through Rd.
4.5.2.2.3.2 Exiting from Unattached.SNK State		
4.5.2.2.3.2#1	4.8 4.9 4.17	If the port supports USB PD or accessories, the port shall transition to AttachWait.SNK when a Source connection is detected, as indicated by the SNK.Rp state on one of its CC pins
4.5.2.2.3.2#2	4.15 4.17	A DRP shall transition to Unattached.SRC within tDRPTransition after the state of both CC pins is SNK.Open for tDRP - dcSRC.DRP * tDRP or if directed.
4.5.2.2.3.2#3	4.12	A Sink with Accessory support shall transition to Unattached.Accessory within tDRPTransition after the state of both

Assertion #	Test Name	Assertion Description
		CC pins is SNK.Open for tDRP - dcSRC.DRP * tDRP or if directed.
4.5.2.2.4 AttachWait.SNK State		
4.5.2.2.4.1 AttachWait.SNK Requirements		
4.5.2.2.4.1#1	4.8 4.9	The port shall not drive VBUS or VCONN
4.5.2.2.4.1#2	4.8 4.9	Both CC pins shall be independently terminated to ground through Rd.
4.5.2.2.4.1#3		It is strongly recommended that a USB 3.1 SuperSpeed device hold off Vbus detection to the device controller until the Attached.SNK state or the DebugAccessory.SNK state is reached, i.e. at least one CC pin is in the SNK.Rp state.
4.5.2.2.4.2 Exiting from AttachWait.SNK State		
4.5.2.2.4.2#1	4.9	A Sink shall transition to Unattached.SNK when the state of both CC pins is SNK.Open for at least tPDDebounce.
4.5.2.2.4.2#2	4.17	A DRP shall transition to Unattached.SRC when the state of both CC pins is SNK.Open for at least tPDDebounce
4.5.2.2.4.2#3	4.8 4.9	The port shall transition to Attached.SNK after the state of only one of the CC1 or CC2 pins is SNK.Rp for at least tCCDebounce and VBUS is detected. Note the Source may initiate USB PD communications which will cause brief periods of the SNK.Open state on both CC pins, but this event will not exceed tPDDebounce.
4.5.2.2.4.2#4		If the port supports Debug Accessory Mode, the port shall transition to DebugAccessory.SNK if the state of both the CC1 and CC2 pins is SNK.Rp for at least tCCDebounce and Vbus is detected.
4.5.2.2.4.2#5		A DRP that strongly prefers the Source role may optionally transition to Try.SRC instead of Attached.SNK when the state of only one CC pin has been SNK.Rp for at least tCCDebounce and Vbus is detected.
4.5.2.2.5 Attached.SNK State		
4.5.2.2.5#1	Not Tested	A port that entered this state directly from Unattached.SNK due to detecting VBUS shall not determine orientation or availability of higher than Default USB Power and shall not use <i>USB PD</i> .
4.5.2.2.5.1 Attached.SNK State Requirements		
4.5.2.2.5.1#1	Untestable	If the port needs to determine the orientation of the connector, is shall do so only upon entry to this state by detecting which CC pin is connected through the cable (i.e., the CC pin that is in the SNK.Rp state).
4.5.2.2.5.1#2	4.8 4.9 4.26	If the port supports signaling on USB SuperSpeed pairs, it shall functionally connect the USB SuperSpeed pairs and maintain the connection during and after a USB PD PR_Swap.

Assertion #	Test Name	Assertion Description
4.5.2.2.5.1#3	4.8 4.9	If the port has entered the Attached.SNK state from the AttachWait.SNK or TryWait.SNK states, only one CC pin will be in the SNK.Rp state. The port shall continue to terminate this CC pin to ground through Rd.
4.5.2.2.5.1#4	4.34	If the port has entered the Attached.SNK state from the Attached.SRC state following a USB PD PR_Swap, the port shall terminate the connected CC pin to ground through Rd.
4.5.2.2.5.1#5	4.8 4.9	The port shall meet the UFP Power Sub-State requirements specified in Section 4.5.2.3.
4.5.2.2.5.1#6	4.8 4.9	By default, upon entry from AttachWait.SNK or Unattached.SNK, VCONN shall not be supplied in the Attached.SNK state.
4.5.2.2.5.1#7	4.26 4.34	If Attached.SNK is entered from Attached.SRC as a result of a USB PD PR_Swap, it shall maintain VCONN supply state, whether on or off, and its data role and connections.
4.5.2.2.5.1#8	4.35	When the port successfully executes USB PD VCONN_Swap operation and was not sourcing VCONN, it shall start sourcing VCONN within tVCONNON
4.5.2.2.5.1#9	4.35	The port shall execute the VCONN_Swap in a make-before-break sequence in order to keep active USB Type-C to USB Type-C cables powered.
4.5.2.2.5.1#10	4.35	When the port successfully executes USB PD VCONN_Swap and was sourcing VCONN, it shall stop sourcing VCONN within tVCONNOFF.
4.5.2.2.5.2 Exiting from Attached.SNK State		
4.5.2.2.5.2#1	4.8 4.9	A port that is not in the process of a USB PD PR_Swap or a USB PD Hard Reset shall transition to Unattached.SNK when VBUS falls below 3.67 V. Note that if Vbus has been adjusted by USB PD to operate above 5V, then the port shall transition to Unattached.SNK when Vbus falls below 80% of the negotiated value.
4.5.2.2.5.2#2	4.34	A port transitioning to Unattached.SNK, If supplying VCONN, shall cease to supply it within tVCONNOFF of exiting Attached.SNK.
4.5.2.2.5.2#3	4.34	After receiving a USB PD PS_RDY from the original Source during a USB PD PR_Swap the port shall transition directly to the Attached.SRC state (i.e. remove Rd from CC, assert Rp on CC and supply VBUS) but shall maintain its VCONN supply state, whether off or on, and its data role/connections.
4.5.2.2.6 Unattached.SRC State		
4.5.2.2.6.1 Unattached.SRC Requirements		
4.5.2.2.6.1#1	4.2 4.4	The port shall not drive VBUS or VCONN
4.5.2.2.6.1#2	4.2 4.4	The port shall source current on both CC pins independently.

Assertion #	Test Name	Assertion Description
4.5.2.2.6.1#3	4.2 4.4	The port shall provide a separate Rp termination on the CC1 and CC2 pins as specified in Table 4-15
4.5.2.2.6.2 Exiting from Unattached.SRC State		
4.5.2.2.6.2#1	4.2 4.4	The port shall transition to AttachWait.SRC when Vbus is vSafe0V and the SRC.Rd state is detected on at least one CC pin
4.5.2.2.6.2#2	4.19	The port shall transition to AttachWait.SRC when Vbus is vSafe0V and the SRC.Ra state is detected on both CC pins.
4.5.2.2.6.2#3	4.1	When a port detects SRC.Ra on one CC pin and SRC.Open on the other, the port shall not transition to AttachWait.SRC.
4.5.2.2.6.2#4	4.15 4.17	A DRP shall transition to Unattached.SNK within tDRP transition after dcSRC.DRP * tDRP
4.5.2.2.6.2#5	4.15 4.17	A DRP shall transition to Unattached.SNK if directed.
4.5.2.2.7 AttachWait.SRC State		
4.5.2.2.7.1 AttachWait.SRC Requirements		
4.5.2.2.7.1#1	4.2 4.4 4.15	The port shall not drive VBUS or VCONN
4.5.2.2.7.1#2	4.2 4.4 4.15	The port shall source current on both CC pins independently.
4.5.2.2.7.1#3	4.2 4.4 4.15	The port shall provide a separate Rp termination on the CC1 and CC2 pins as specified in Table 4-15
4.5.2.2.7.2 Exiting from AttachWait.SRC State		
4.5.2.2.7.2#1	4.2 4.4 4.15	The port shall transition to Attached.SRC when Vbus is in vSafe0V and the SRC.Rd state is detected on exactly one of the CC pins for at least tCCDebounce.
4.5.2.2.7.2#2	4.5	If the port supports Audio Adapter Accessory Mode, it shall transition to AudioAccessory when the SRC.Ra state is detected on both CC pins for at least tCCDebounce.
4.5.2.2.7.2#3	Not Tested	If the port supports Debug Accessory Mode, it shall transition to UnorientedDebugAccessory.SRC when the SRC.Rd state is detected on both CC pins for at least tCCDebounce
4.5.2.2.7.2#4	4.3	A Source shall transition to Unattached.SRC and a DRP to Unattached.SNK when the SRC.Open state is detected on both CC pins.
4.5.2.2.7.2#5	4.2 4.15	A Source shall transition to Unattached.SRC and a DRP to Unattached.SNK when the SRC.Open state is detected on one CC pin and the SRC.Ra state is detected on the other CC pin.

Assertion #	Test Name	Assertion Description
4.5.2.2.7.2#6		A DRP that strongly prefers the Sink role may optionally transition to Try.SNK instead of Attached.SRC when Vbus is at vSafe0V and the SRC.Rd state is detected on exactly one of the CC1 or CC2 pins for at least tCCDebounce.
4.5.2.2.8 Attached.SRC State		
4.5.2.2.8.1 Attached.SRC Requirements		
4.5.2.2.8.1#1	Untestable	If the port needs to determine the orientation of the connector, it shall do so only upon entry to the Attached.SRC state by detecting which pin is in the SRC.Rd state
4.5.2.2.8.1#2	4.2 4.4 4.15	If the port has entered this state from the AttachWait.SRC state or the Try.SRC state, the SRC.Rd state will be on only one CC pin. The port shall source current on this CC pin and monitor its state.
4.5.2.2.8.1#3	4.34	If the port has entered this state from the Attached.SNK state as the result of a USB PD PR_Swap, the port shall source current on the connected CC pin and monitor its state.
4.5.2.2.8.1#4	4.2 4.4 4.15	The port shall provide an Rp as specified in Table 4-15.
4.5.2.2.8.1#5	4.2 4.4 4.15	The port shall supply Vbus current at the level it advertises on Rp.
4.5.2.2.8.1#6	4.2 4.4 4.15	The port shall supply Vbus within tVbusON of entering this state, and for as long as it is operating as a power source.
4.5.2.2.8.1#7	4.2 4.15 4.18	The port shall not initiate any USB_PD communications until Vbus reaches vSafe5V.
4.5.2.2.8.1#8	4.2 4.26	If the port supports signaling on USB SS pairs, it shall functionally connect the USB SS pairs
4.5.2.2.8.1#9	4.2	If the port supports signaling on USB SS pairs, is shall either apply Vconn unconditionally to the CC pin not in the SRC.Rd state, or apply Vconn to the CC pin in the SRC.Ra state.
4.5.2.2.8.1#10	4.2	If the port supplies Vconn, it shall do so within tVconnON
4.5.2.2.8.1#11	4.34	The port shall not supply Vconn if it has entered this state as a result of a USB PD PR_Swap and was not previously supplying Vconn.
4.5.2.2.8.1#12	4.27	When the port successfully executes USB PD Vconn_Swap operation and was sourcing Vconn, it shall stop sourcing Vconn within tVconnOFF.
4.5.2.2.8.1#13	4.27	The port shall execute the Vconn_Swap in a make-before-break sequence in order to keep active USB Type-C to USB Type-C cables powered.

Assertion #	Test Name	Assertion Description
4.5.2.2.8.1#14	4.27	When the port successfully executes USB PD Vconn_Swap operation and was not sourcing Vconn, it shall start sourcing Vconn within tVconnON.
4.5.2.2.8.2 Exiting from Attached.SRC State		
4.5.2.2.8.2#1	4.2	A Source shall transition to Unattached.SRC when the SRC.Open state is detected on the monitored CC pin.
4.5.2.2.8.2#2	4.15	When the SRC.Open state is detected on the monitored CC pin, a DRP shall transition to Unattached.SNK unless it strongly prefers the Source role.
4.5.2.2.8.2#3	4.15	When the SRC.Open state is detected on the monitored CC pin and a DRP strongly prefers the Source state, it shall transition TryWait.SNK.
4.5.2.2.8.2#4	4.15	A DRP that would enter Try.SRC from AttachWait.SNK shall enter TryWait.SNK for a Sink detach from Attached.SRC.
4.5.2.2.8.2#5	4.2 4.15	A port shall cease to supply VBUS within tVBUSOFF of exiting Attached.SRC
4.5.2.2.8.2#6	4.2 4.7 4.35	A port that is supplying VCONN shall cease to supply it within tVCONNOFF of exiting Attached.SRC, unless it is exiting as a result of a USB PD PR_Swap.
4.5.2.2.8.2#7	4.26	After a USB PD PR_Swap is accepted (Accept message is received or acknowledged), a DRP shall transition directly to the Attached.SNK state (remove Rp from CC, assert Rd on CC and stop supplying VBUS)
4.5.2.2.8.2#8	4.26	After a USB PD PR_Swap is accepted (Accept message is received or acknowledged), a DRP shall maintain its current data role, connection and VCONN supply state.
4.5.2.2.9 Try.SRC State		
4.5.2.2.9#1		Note: If both Try.SRC and Try.SNK mechanisms are implemented, only one shall be enabled by the port at a given time.
4.5.2.2.9.1 Try.SRC Requirements		
4.5.2.2.9.1#1	4.17 4.18	The port shall not drive VBUS or VCONN.
4.5.2.2.9.1#2	4.17 4.18	The port shall source current on both CC pins independently.
4.5.2.2.9.1#3	4.17 4.18	The port shall provide an Rp as specified in Table 4-15
4.5.2.2.9.2 Exiting from Try.SRC State		
4.5.2.2.9.2#1	4.18	The port shall transition to Attached.SRC when the SRC.Rd state is detected on exactly one of the CC pins for at least tPDDebounce.
4.5.2.2.9.2#2	4.17	The port shall transition to TryWait.SNK after tDRPTry and the

Assertion #	Test Name	Assertion Description
		SRC.Rd state has not been detected.
4.5.2.2.10 TryWait.SNK State		
4.5.2.2.10.1 TryWait.SNK Requirements		
4.5.2.2.10.1#1	4.17	The port shall not drive VBUS or VCONN.
4.5.2.2.10.1#2	4.17	Both CC pins shall be independently terminated to ground through Rd.
4.5.2.2.10.2 Exiting from TryWait.SNK State		
4.5.2.2.10.2#1	4.17	The port shall transition to Attached.SNK after tCCDebounce if or when VBUS is detected.
4.5.2.2.10.2#2	4.17	The port shall transition to Unattached.SNK when the state of both CC pins is SNK.Open for at least tPDDebounce
4.5.2.2.11 Try.SNK State		
4.5.2.2.11#1	BC	Note: If both Try.SRC and Try.SNK mechanisms are implemented, only one shall be enabled by the port at a given time.
4.5.2.2.11.1 Try.SNK Requirements		
4.5.2.2.11.1#1	4.7.2,4,5	The port shall not drive Vbus or Vconn
4.5.2.2.11.1#2	4.7.x	Both the CC1 and CC2 pins shall be independently terminated to ground through Rd.
4.5.2.2.11.2 Exiting from Try.SNK State		
4.5.2.2.11.2#1	4.7.4,5	The port shall wait for tDRPTry and only then begin monitoring the CC1 and CC2 pins for the SNK.Rp state.
4.5.2.2.11.2#2	4.7.5	The port shall transition to Attached.SNK when the SNK.Rp state is detected on exactly one of the CC1 or CC2 pins for at least tPDDebounce and Vbus is detected.
4.5.2.2.11.2#3	4.7.4	The port shall transition to TryWait.SRC if SNK.Rp state is not detected for tPDDebounce.
4.5.2.2.11.2#4		A Sink with Accessory Support shall transition to Unsupported.Accessory if SNK.Rp state is not detected for tDRPTryWait.
4.5.2.2.12 TryWait.SRC State		
4.5.2.2.12.1 TryWait.SRC Requirements		
4.5.2.2.12.1#1	4.7.4	The port shall not drive Vbus or Vconn
4.5.2.2.12.1#2	4.7.4	The port shall source current on both CC pins.
4.5.2.2.12.1#3		The port shall provide a separate Rp termination on the CC1 and CC2 pins as specified in Table 4-15.

Assertion #	Test Name	Assertion Description
4.5.2.2.12.2 Exiting from TryWait.SRC State		
4.5.2.2.12.2#1		The port shall transition to Attached.SRC when Vbus is at vSafe0V and the SRC.Rd state is detected on exactly one of the CC pins for at least tCCDebounce.
4.5.2.2.12.2#2		The port shall transition to Unattached.SNK after tDRPtry if neither of the CC1 or CC2 pins are in the SRC.Rd state.
4.5.2.2.13 Unattached.Accessory State		
4.5.2.2.13.1 Unattached.Accessory Requirements		
4.5.2.2.13.1#1	4.1 4.12 4.14	The port shall not drive VBUS or VCONN.
4.5.2.2.13.1#2	4.12 4.14	The port shall source current on both CC pins independently.
4.5.2.2.13.1#3	4.12 4.14	The port shall provide an Rp as specified in Table 4-15.
4.5.2.2.13.2 Exiting from Unattached.Accessory State		
4.5.2.2.13.2#1	4.12	The port shall transition to AttachWait.Accessory when the state of both pins is SRC.Ra or SRC.Rd
4.5.2.2.13.2#2	4.14	A port that supports Vconn-Powered accessories also shall transition to AttachWait.Accessory when the state of one CC pin is SRC.Ra and the other is SRC.Rd
4.5.2.2.13.2#3	4.11	If at least one CC is in SRC.Open, or if SRC.Ra is on one CC pin and SRC.Rd is on the other and the port does not support Vconn-powered accessories, then the port shall transition to Unattached.SNK within tDRPTransition after dcSRC.DRP * tDRP, or if directed.
4.5.2.2.14 AttachWait.Accessory State		
4.5.2.2.14.1 AttachWait.Accessory Requirements		
4.5.2.2.14.1#1	4.12 4.14 4.19	The port shall not drive VBUS or VCONN.
4.5.2.2.14.1#2	4.12 4.14 4.19	The port shall source current on both CC pins independently.
4.5.2.2.14.1#3	4.12 4.14 4.19	The port shall provide an Rp as specified in Table 4-15.
4.5.2.2.14.2 Exiting from AttachWait.Accessory State		
4.5.2.2.14.2#1	4.12	If the port supports Audio Adapter Accessory Mode, it shall

Assertion #	Test Name	Assertion Description
	4.19	transition to AudioAccessory when the state of both CC pins is SRC.Ra for at least tCCDebounce
4.5.2.2.14.2#2	Not Teseted	If the port supports Debug Accessory Mode, it shall transition to DebugAccessory when the state of both CC pins is SRC.Rd for at least tCCDebounce.
4.5.2.2.14.2#3	4.14	The port shall transition to Unattached.SNK when the state of either CC pin is SRC.Open for at least tCCDebounce
4.5.2.2.14.2#4	4.14	If the port supports VCONN-powered accessories, it shall transition to PoweredAccessory state if the state of one to its CC pins is SRC.Rd and the state of the other CC pin is SRC.Ra concurrently for at least tCCDebounce
4.5.2.2.15 AudioAccessory State		
4.5.2.2.15.1 AudioAccessory Requirements		
4.5.2.2.15.1#1	4.5 4.12 4.19	The port shall reconfigure its pins as detailed in Appendix A.
4.5.2.2.15.1#2	4.5 4.12 4.19	The port shall not drive VBUS or VCONN.
4.5.2.2.15.1#3	4.12 4.19	A port that sinks current from the audio accessory over VBUS shall not draw more than 500 mA.
4.5.2.2.15.1#4	4.5 4.12 4.19	The port shall provide an Rp as specified in Table 4-15.
4.5.2.2.15.1#5	4.5 4.19	The port shall source current on at least one of the CC pins and monitor to detect when the CC pin state is no longer SRC.Ra.
4.5.2.2.15.1#6		If the port sources and monitors only one CC pin, then it shall ensure that the termination on the unmonitored CC pin does not affect the monitored signal when the port is connected to an Audio Accessory that may short both CC pins together.
4.5.2.2.15.2 Exiting from AudioAccessory State		
4.5.2.2.15.2#1	4.12 4.19	If the port is a Sink, the port shall transition to Unattached.SNK when the state of the monitored CC pin is SRC.Open for at least tCCDebounce.
4.5.2.2.15.2#2	4.5	If the port is a Source or DRP, the port shall transition to Unattached.SRC when the SRC.Open state is detected on the monitored CC pin for at least tCCDebounce.
4.5.2.2.16 DebugAccessory State		
4.5.2.2.16.1 DebugAccessory Requirements		
4.5.2.2.16.1#1	Not Tested	This mode is for debug only and shall not be used for communicating with commercial products.

Assertion #	Test Name	Assertion Description
4.5.2.2.16.1#2	4.6 4.13 4.20	The port shall not drive VBUS or VCONN.
4.5.2.2.16.1#3	Not Tested	The port shall drive Rp as specified in Table 4-13.
4.5.2.2.16.1#4	Not Tested	The port shall source current on at least one of the CC pins and monitor to detect when the CC pin state is no longer SRC.Rd.
4.5.2.2.16.1#5	Not Tested	If the port monitors only one CC pin, it shall source current on the monitored pin and may source current or not on the unmonitored pin.
4.5.2.2.16.3 Exiting from DebugAccessory State		
4.5.2.2.16.2#1	Not Tested	If the port is a Sink or DRP, the port shall transition to Unattached.SNK when the SRC.Open state is detected on the monitored CC pin(s).
4.5.2.2.16.2#2	Not Tested	If the port is a Source, the port shall transition to Unattached.SRC when the SRC.Open state is detected on the monitored CC pin(s).
4.5.2.2.19 Powered.Accessory State		
4.5.2.2.19.1 Powered.Accessory Requirements		
4.5.2.2.19.1#1	Untestable	If the port needs to determine the orientation of the connector, it shall do so only upon entry to the PoweredAccessory state by detecting which CC pin is connected through the cable (in the SRC.Rd state).
4.5.2.2.19.1#2	4.14	The port shall advertise either 1.5 A or 3.0 A (see Table 4-13) on the connected CC pin and monitor its state.
4.5.2.2.19.1#3	4.14	The port shall supply VCONN (2.7 V minimum) on the unused CC pin within tVCONNON-PA of entering the PoweredAccessory state.
4.5.2.2.19.1#4	4.14	The port shall not drive VBUS.
4.5.2.2.19.1#5	4.14	When the port initially enters the PoweredAccessory state it shall operate as a DFP.
4.5.2.2.19.1#6	4.14	The port shall use USB Power Delivery Structured Vendor Defined Messages (Structured VDMs) to identify this accessory and enter an Alternate Mode.
4.5.2.2.19.2 Exiting from PoweredAccessory State		
4.5.2.2.19.2#1	4.14	The port shall transition to Unattached.SNK when the SRC.Open state is detected on the monitored CC pin.
4.5.2.2.19.2#2	4.14	The port shall transition to Unattached.SNK if the attached device is not a VCONN-Powered Accessory.
4.5.2.2.19.2#3	4.14	The port shall transition to Unsupported.Accessory if it does not successfully enter an Alternate Mode within tAMETimeout (see Section 5.1).

Assertion #	Test Name	Assertion Description
4.5.2.2.19.2#4	4.14	The port shall cease to supply VCONN within tVCONNOFF of exiting the PoweredAccessory state.
4.5.2.2.20 Unsupported.Accessory State		
4.5.2.2.20.1 Unsupported.Accessory Requirements		
4.5.2.2.20.1#1	4.14	Only one CC pin shall be in the SRC.Rd state.
4.5.2.2.20.1#2	4.14	The port shall advertise Default USB Power (see Table 4-13) on the connected CC pin and monitor its voltage.
4.5.2.2.20.1#3	4.14	The port shall not drive VBUS or VCONN.
4.5.2.2.20.1#4	4.14	A Sink with Accessory Support shall provide user notification that it does not recognize or support the attached accessory.
4.5.2.2.20.2 Exiting from Unsupported.Accessory		
4.5.2.2.20.2#1	4.14	The port shall transition to Unattached.SNK when the SRC.Open state is detected on the monitored CC pin.
4.5.2.3 UFP Power Sub-State Requirements		
4.5.2.3#1	4.31	When in the Attached.SNK state and the Source is supplying default VBUS, the port shall operate in one of the sub-states shown in Figure 4-17.
4.5.2.3#2	4.31	The port in Attached.SNK shall remain within the Sink Power Sub-States until either VBUS is removed or a USB PD contract is established with the Source.
4.5.2.3.1 PowerDefault.UFP Sub-State		
4.5.2.3.1.1 PowerDefault.UFP Requirements		
4.5.2.3.1.1#1	4.31	The port shall draw no more than the default USB power from VBUS.
4.5.2.3.1.1#2	4.31	If the port wants to consume more than the default USB power, it shall monitor vRd to determine if more current is available from the Source.
4.5.2.3.1.2 Exiting from PowerDefault.UFP		
4.5.2.3.1.2#1	4.31	For any change on CC indicating a change in allowable power, the port shall not transition until the new vRd on CC has been stable for tPDDebounce.
4.5.2.3.1.2#2	4.31	For a vRd in the vRd-1.5 range, the port shall transition to the Power1.5.SNK Sub-State.
4.5.2.3.1.2#3	4.31	For a vRd in the vRd-3.0 range, the port shall transition to the Power3.0.SNK Sub-State.
4.5.2.3.2 Power 1.5.UFP Sub-State		

Assertion #	Test Name	Assertion Description
4.5.2.3.2.1 Power 1.5.UFP Sub-State Requirements		
4.5.2.3.2.1#1	4.31	The port shall draw no more than the 1.5 A from VBUS.
4.5.2.3.2.1#2	4.31	The port shall monitor vRd while it is in this sub-state.
4.5.2.3.2.2 Exiting from Power 1.5.UFP Sub-State		
4.5.2.3.2.2#1	4.31	For any change on CC indicating a change in allowable power, the port shall not transition until the new vRd on CC has been stable for tPDDebounce.
4.5.2.3.2.2#2	4.31	For a vRd in the vRd-USB range, the port shall transition to the PowerDefault.SNK Sub-State and reduce its power consumption to the new range within tSinkAdj.
4.5.2.3.2.2#3	4.31	For a vRd in the vRd-3.0 range, the port shall transition to the Power3.0.SNK Sub-State.
4.5.2.3.3 Power3.0.UFP Sub-State		
4.5.2.3.3.1 Power3.0.UFP Requirements		
4.5.2.3.3.1#1	4.31	The port shall draw no more than the 3.0 A from VBUS.
4.5.2.3.3.1#2	4.31	The port shall monitor vRd while it is in this sub-state.
4.5.2.3.3.1 Power3.0.UFP Requirements		
4.5.2.3.3.2#1	4.31	For any change on CC indicating a change in allowable power, the port shall not transition until the new vRd on CC has been stable for tPDDebounce.
4.5.2.3.3.2#2	4.31	For a vRd in the vRd-USB range, the port shall transition to the PowerDefault.SNK Sub-State and reduce its power consumption to the new range within tSinkAdj.
4.5.2.3.3.2#3	4.31	For a vRd in the vRd-1.5 range, the port shall transition to the Power1.5.SNK Sub-State and reduce its power consumption to the new range within tSinkAdj.
4.5.2.4 Cable eMarker State Machine Requirements		
4.5.2.4.1 Cable Power On State		
4.5.2.4.1.1 Cable Power On State Requirements		
4.5.2.4.1.1#1	BC	In the Cable Power On State, each eMarker in the cable shall power on
4.5.2.4.1.1#2	4.1.3	The cable shall not respond to SOP' and SOP" commands in this state.
4.5.2.4.1.2 Exiting from Cable Power On State		
4.5.2.4.1.2#1	4.14.1	Each eMarker in a passive or active cable shall transition to Assign Cable SOP* within tVconnStable.

Assertion #	Test Name	Assertion Description
4.5.2.4.2 Respond to SOP'/' State		
4.5.2.4.2#1	BC	The powered eMarker in a passive cable shall respond to SOP' in this state.
4.5.2.4.2#2	Untestable	Each cable emarker in an active cable shall respond to a pre-set SOP' or SOP".
4.5.2.4.2#3	Untestable	If only one eMarker exists in the cable, it shall only respond to SOP'
4.5.2.4.2#4	PD	Cable designers shall ensure that the eMarker works correctly in the presence of ground and Vconn maximum IR drop.
4.5.2.4.2.1 Respond to SOP'/' State Requirements		
4.5.2.4.2.1#1	BC	Each eMarker in the passive or active cable shall be able to respond to any USB PD communication sent to its pre-set SOP' or SOP"
4.5.2.4.2.1#2	BC	For a passive cable, only one eMarker should be powered at a time and shall respond to SOP' only.
4.5.2.4.2.1#3	Untestable	If two eMarkers exist in a passive or active cable and are powered at the same time, then only one shall respond to a pre-set SOP' and the other to SOP".
4.5.2.4.2.1#4	Untestable	The assignment of SOP' and SOP" is fixed for each eMarker in a cable and shall not be dynamically set when power is applied to Vconn.
4.5.2.4.2.2 Exiting from Respond to SOP'/' State		
4.5.2.4.2.2#1	4.14.1	Each eMarker in the cable shall transition to Cable Power On upon sensing Vconn less than vVconnDisconnect or upon a Power On Reset event.
4.5.2.4.2.2#2	4.14.1	Each eMarker in the cable shall transition to Cable Power On upon sensing a Hard Reset or Cable Reset.
4.5.2.5 Cable Ra Management State Machine Requirements		
4.5.2.5.1 Ra Applied State		
4.5.2.5.1.1 Ra Applied State Requirements		
4.5.2.5.1.1#1	4.14.1	Each eMarker in the cable shall apply Ra to Vconn within tRaReconnect
4.5.2.5.1.2 Exiting from Ra Applied State		
4.5.2.5.1.2#1	Untestable	Each eMarkers in a cable shall transition to the Ra Weakened state when Vconn is greater than vVconnDisconnect for tRaWeaken
4.5.2.5.2 Ra Weakened State		
4.5.2.5.2.1 Ra Weakened State Requirements		
4.5.2.5.2.1#1	Untestable	The eMarker in the cable shall remove or weaken Ra

Assertion #	Test Name	Assertion Description
4.5.2.5.2.1#2	4.1.3 4.14.1	Passive cables shall meet the Power for electronically marked passive cables defined in Table 4-6.
4.5.2.5.2.1#3	4.14.1	Active cables shall meet the Power for Active Cables in Table 4-6.
4.5.2.5.2.2 Exiting from Ra Weakened State		
4.5.2.5.2.2#1	4.14.1	Each eMarker in a cable shall transition to the Ra Applied state when Vconn is below vVconnDisconnect.
4.5.3.2.2 Legacy Host Port to UFP Behavior		
4.5.3.2.2#1	4.29	The value of Rp shall indicate an advertisement of Default USB Power (See Table 4-10), even though the cable itself can carry 3 A.
4.5.3.2.4 Legacy Host Port to DRP Behavior		
4.5.3.2.4#1	4.29	The value of Rp shall indicate an advertisement of Default USB Power (See Table 4-10), even though the cable itself can carry 3 A.
4.6 Power		
4.6#1	4.25 4.31	All USB Type-C-based devices shall support USB Type-C Current and may support other USB-defined methods for power.
4.6#2	4.32	The following order of precedence of power negotiation shall be followed: USB BC 1.2 supersedes the USB 2.0 and USB 3.1 specifications, USB Type-C Current at 1.5 A and 3.0 A supersedes USB BC 1.2, and USB Power Delivery supersedes USB Type-C Current.
4.6#3	4.32	Once the PD mode (e.g. a power contract has been negotiated) has been entered, the device shall abide by that power contract ignoring any other previously made or offered by the USB Type-C Current, USB BC 1.2 or USB 2.0 and USB 3.1 specifications.
4.6#4	4.32	When the PD mode is exited, the device shall fallback in order to the USB Type-C Current, USB BC 1.2 or USB 2.0 and USB 3.1 specification power levels.
4.6#5	4.1	All USB Type-C ports shall tolerate being connected to USB power source supplying default USB power, e.g. a host being connected to a legacy USB charger that always supplies VBUS.
4.6.1 Power Requirements during USB Suspend		
4.6.1.1 VBUS Requirements during USB Suspend		
4.6.1.1#1	4.33	USB suspend power rules shall apply when the USB Type-C Current is at the Default USB Power level or when USB PD is being used and the Suspend bit is set appropriately.
4.6.1.2 VCONN Requirements during USB Suspend		
4.6.1.2#1	4.24	If the DFP supplies VBUS power during USB suspend, it shall also supply at least 70 mW to VCONN.

Assertion #	Test Name	Assertion Description
4.6.1.2#2	4.14.4	Electronically marked cables shall meet the requirements in Table 4-6 during USB suspend.
4.6.2 VBUS Power Provided Over a USB Type-C Cable		
4.6.2#1	CabCon PD	USB Power Delivery is an optional capability that is intended to work over un-modified USB Type-C to USB Type-C cables, therefore any USB Type-C cable assembly that incorporates electronics that gets it power from VBUS shall be tolerant up to 20 V.
4.6.2.1 USB Type-C Current		
4.6.2.1#1	4.31	A UFP that takes advantage of the additional current offered (e.g., 1.5 A or 3.0 A) shall monitor the CC pins and shall adjust its current consumption within tSinkAdj to remain within the value advertised by the DFP.
4.6.2.1#2	4.32	While a USB PD contract is in place, a UFP is not required to monitor USB Type-C Current advertisements and shall not respond to USB Type-C Current advertisements.
4.6.2.1#3	4.2	The DFP shall source VBUS to the UFP within tVBUSON.
4.6.2.1#4	4.25	VBUS shall be in the specified voltage range at the advertised current.
4.6.2.1#5	Not Tested	A port sourcing VBUS shall protect itself from a sink that draws current in excess of the port's USB Type-C Current advertisement.
4.6.2.1#6	4.31	If the UFP wants to consume more than the default USB current, it shall track vRd to determine the maximum current it may draw.
4.6.2.2 USB Battery Charging		
4.6.2.2#1	4.25	USB Type-C-based BC 1.2 chargers that are capable of supplying at least 1.5 A shall advertise USB Type-C Current at the 1.5 A level, otherwise the charger shall advertise USB Type-C Current at the Default USB Power level.
4.6.2.3 Proprietary Power Source		
4.6.2.3#1	4.25	A proprietary power source (i.e., battery charger) with a USB Type-C-captive cable or a USB Type-C receptacle that is capable of supplying at least 1.5 A and less than 3.0 A shall advertise USB Type-C Current at least at the 1.5 A level.
4.6.2.3#2	4.25	A proprietary power source with a USB Type-C-captive cable or a USB Type-C receptacle that is capable of supplying at least 3.0 A shall advertise USB Type-C Current at least at the 3.0 A level.
4.6.2.4 USB Power Delivery		
4.6.2.4#1	4.2	When USB PD is implemented, USB PD Bi-phase Mark Coded (BMC) carried on the CC wire shall be used for USB PD communications between USB Type-C ports.

Assertion #	Test Name	Assertion Description
4.6.2.4#2	4.2	At attach, VBUS shall be operationally stable prior to initiating USB PD communications.
4.6.2.4#3	4.25	While a USB PD contract is in place, the provider shall advertise a USB Type-C Current of either 1.5 A or 3.0 A.
4.6.3 Supporting USB PD BFSK in Addition to USB PD BMC		
4.6.3#1	Not Tested	USB Type-C-based products that support USB PD BFSK and request a voltage greater than 5V shall supply protect the CC inputs from termination voltages higher than 5V as some adapters may present an Rp pulled up to VBUS that may be as high as 20V.
4.6.3#2	Not Tested	USB PD BFSK shall only be used if USB PD BMC fails to establish PD communication, i.e. fails to receive a USB PD GoodCRC message in response to a USB PD Capabilities message following two hard resets.
4.6.3#3	Not Tested	USB Type-C-based UFPs that support USB PD BFSK and want to request more than 1.5 A shall supply VCONN and confirm that the cable is electronically marked and capable of the desired current level (see Section 5.2.2).
4.7 USB Hubs		
4.7#1	4.39	USB hubs implemented with one or more USB Type-C connectors shall comply with the USB 3.1 Specification.
4.7#2	4.40	USB hubs shall have one UFP that may be a Charging UFP (See Section 4.8.3).
4.7#3	IOP	The hub shall clearly identify to the user its UFP.
4.7#4	4.40	USB hub's DFPs shall not have DRP capability.
4.7#5	4.40	CC pins are used for port-to-port connections and shall be supported on all USB Type-C connections on the hub.
4.7#6	4.40	USB hub ports shall not implement or pass-through Alternate or Accessory Modes.
4.7#7	4.40	SBU pins shall not be connected (zSBU Termination) on any USB hub port.
4.7#8	4.25	The USB hub's DFPs shall support power source requirements for a DFP.
4.8 Chargers		
4.8.1 DFP as a Power Source		
4.8.1#1	4.25	When a charger with a USB Type-C receptacle or a USB Type-C captive cable, it shall follow all the applicable requirements.
4.8.1#2	4.25	A DFP shall expose its power capabilities using the USB Type-C Current method and it may additionally support other USB-standard methods (USB BC 1.2 or USB-PD).

Assertion #	Test Name	Assertion Description
4.8.1#3	4.25	A USB Type-C power provider advertising its current capability using USB BC 1.2 shall meet the requirements in Section 4.6.2.2 regarding USB Type-C Current advertisement.
4.8.1#4	4.25	A USB Type-C power provider that has negotiated a USB-PD contract shall meet the requirements in Section 4.6.2.4 regarding USB Type-C Current advertisement.
4.8.1#5	Untestable	If a USB Type-C power provider is capable of supplying a voltage greater than default VBUS, it shall fully conform to the USB-PD specification, and shall negotiate its power contracts using only USB-PD.
4.8.1#6	TD 4.15 TD 4.26 TD 4.34	If a USB Type-C power provider is capable of reversing source and sink power roles, it shall fully conform to the USB-PD specification, and shall negotiate its power contracts using only USB-PD.
4.8.1#7	Not Tested Untestable?	If a USB Type-C power provider is capable of supplying a current greater than 3.0 A, it shall use the USB-PD Discovery Identity to determine the current carrying capacity of the cable.
4.8.1.1 Chargers with USB Type-C Receptacles		
4.8.1.1#2	4.1	A charger with a USB Type-C receptacle (DFP) shall only apply power to VBUS when it detects a UFP is attached and shall remove power from VBUS when it detects the UFP is detached (vOPEN).
4.8.1.1#3	4.25	A charger with a USB Type-C receptacle shall not advertise current exceeding 3.0 A except when it uses the USB-PD Discover Identity mechanism to determine the cable's actual current carrying capability and then it shall limit the advertised current accordingly.
4.8.1.2 Chargers with USB Type-C Captive Cables		
4.8.1.2#1	4.1	A charger with a USB Type-C captive cable that supports USB PD shall only apply power to VBUS when it detects a UFP is attached and shall remove power from VBUS when it detects the UFP is detached (vOPEN).
4.8.1.2#2	PD/CabCon/IOP	A charger with a USB Type-C captive cable shall limit its current advertisement so as not to exceed the current capability of the cable (up to 5 A).
4.8.2 Non-USB Charging Methods		
4.8.2#1	4.25	When implemented, a proprietary charging method shall only be used to establish identify and/or direct a current level at default VBUS voltage in a manner not defined by the USB methods.
4.8.2#2	Untestable	When implemented, a proprietary charging method shall only define the current level and shall not change the voltage delivered on VBUS.
4.8.2#3	Untestable	When implemented, a proprietary charging method shall not alter the DFP's role to source VBUS or the UFP's role to sink VBUS.

Assertion #	Test Name	Assertion Description
4.8.2#4	Untestable	A product with a USB Type-C connector that sinks power may support proprietary charging methods, these products shall not support methods that redefine VBUS voltage beyond what is defined by the USB 2.0 and USB 3.1 specifications.
4.8.3 Sinking UFP		
4.8.3#1	4.15 4.17 4.18	The Sinking DFP shall follow the rules for a DRP (See Section 4.5.1.4 and Figure 4-15).
4.8.3#2	4.15 4.17 4.18	The sinking DFP shall support USB PD and shall support the DR_Swap command.
4.8.4 Charging UFP		
4.8.4#1	4.15 4.17 4.18	The Charging UFP shall follow the rules for a DRP (See Section 4.5.1.4 and Figure 4-15).
4.8.4#2	4.25	The Charging UFP shall also follow the requirements for the DFP as Power Source (See Section 4.8.1).
4.8.4#3	4.22	The Charging UFP shall support USB PD and shall support the DR_Swap command.
4.8.5 Charging a System with a Dead Battery		
4.8.5#1	4.37	A system that supports being charged by USB whose battery is dead shall apply Rd to both CC1 and CC2 and follow all UFP rules.
4.9 Electronically Marked Cables		
4.9#1	BC	All USB Full-Featured Type-C cables shall be electronically marked.
4.9#2	BC	Electronically marked cables shall support USB Power Delivery Structured VDM Discover Identity command directed to SOP'.
4.9#3	PD	After an explicit USB PD contract has been negotiated, only the DFP shall communicate with SOP'.
4.9#4	4.1.3 4.14.1	Passive cables that include an eMarker shall follow the Cable State Machine defined in Section 4.5.2.4 and Figure 4-20
4.9#5		Once Vconn is available, all electronically marked cables shall use it as the only power source.
4.9#6		Within tVconnSwitch, the cable shall switch from Vbus to Vconn
4.9#7	4.14.1 4.14.5	Cables that include an eMarker shall meet the maximum power defined in Table 4-6.
4.9#8	4.1.3	When VCONN is not present, a powered cable shall not interfere with normal CC operation including UFP detection, current advertisement and USB PD operation.

Assertion #	Test Name	Assertion Description
4.9#6	BC	The isolation elements (Iso) shall prevent VCONN from traversing end-to-end through the cable.
4.9.2 Active Cables		
4.9.2#1	BC	Active cables with data bus signal conditioning in both plugs shall implement SOP' and may implement SOP''.
4.9.2#3	4.14.4,5 PD	The eMarker in the active cable shall identify the number of TX/RX lanes supported in the cable.
4.10 VCONN-Powered Accessories		
4.10#1	4.23	When operating in the UFP role and when VBUS is not present, VCONN-powered accessories shall treat the application of VCONN as an attach signal, and shall respond to USB Power Delivery messages.
4.10#2	4.23	When powered by only VCONN, a VCONN-powered accessory shall negotiate an Alternate Mode.
4.10#3	4.23	VCONN-powered accessories shall be able to operate over a range of 2.7 V to 5.5 V on VCONN.
4.10#4	4.23	The removal of VCONN when VBUS is not present shall be treated as a detach event.
4.11 Parameter Values		
4.11.1 Termination Parameters		
4.11.1#1	BC	Table 4-13 provides the values that shall be used for the DFP's Rp or current source.
4.11.1#2	BC	Other pull-up voltages shall be allowed if they remain less than 5.5 V and fall within the correct voltage ranges on the UFP side – see Table 4-21, Table 4-22 and Table 4-23
4.11.1#3	CabCon	For Rp when implemented in the USB Type-C plug on a USB Type-C to USB 3.1 Standard-A Cable Assembly, a USB Type-C to USB 2.0 Standard-A Cable Assembly, a USB Type-C to USB 2.0 Micro-B Receptacle Adapter Assembly or a USB Type-C captive cable connected to a USB host, a value of 56 kOhms +- 5% shall be used, in order to provide tolerance to IR drop on VBUS and GND in the cable assembly.
4.11.1#4	BC	Transitions between Rd implementations that do not exceed tCCDebounce shall not be interpreted as exceeding the wider Rd range.
4.11.1#5	BC	Table 4-14 provides the methods and values that shall be used for the UFP's Rd implementation.
4.11.2 Timing Parameters		
4.11.2#1	BC	Table 4-18 provides the timing values that shall be met for delivering power over VBUS and VCONN.

Assertion #	Test Name	Assertion Description
4.11.2#2	BC	Table 4-19 provides the timing values that shall be met for DRPs.
4.11.2#3	BC	tDRP is the period a DRP shall complete a Source to Sink and back advertisement.
4.11.2#4	BC	dcDFP.DRP is the percent of time that a DRP shall advertise Source during tDRP.
4.11.2#5	BC	tDRRPTransition is the time a DRP shall complete transitions between Source and Sink roles during role resolution.
4.11.2#6	BC	For CC connections, tCCDebounce is the time a port shall wait before it can determine it is attached.
4.11.2#7	BC	For CC connections, tPDDebounce is the time a port shall wait before it can determine it is either detached or there has been a change in the USB Type-C current.
4.11.2#8	BC	For CC connections, tErrorRecovery is the time a self-powered port shall remain in the ErrorRecovery state.
4.11.3 Voltage Parameters		
4.11.3#1	BC	Table 4-21, Table 4-22 and Table 4-23 provide the CC voltage values that a Source shall use to detect what is attached based on the USB Type-C Current advertisement (Default USB, 1.5 A @ 5 V, or 3.0 A @ 5 V) that the Source is offering.
4.11.3#2	BC	Table 4-24 provides the CC voltage values that shall be detected across a Sink's Rd for a Sink that does not support higher than default USB Type-C Current Source advertisements.
4.11.3#3	BC	Table 4-25 provides the CC voltage values that shall be detected across a Sink's Rd for a Sink that implements detection of higher than default USB Type-C Current Source advertisements.
5 USB4 Discovery and Entry		
5.2 USB4 Functional Requirements		
5.2.1#1		USB4 hosts with DRD support shall respond to USB PD Discover ID command with both DFP and UFP VDOs
5.2.2 USB4 Device Functional Requirements		
5.2.2#1		USB4 devices shall respond to USB Discover ID command with UFP VDOs
5.2.2#2	TD 4.13.3	USB4 devices shall provide a USB interface exposing a USB Billboard Device Class when it cannot connect as a USB4 device within tUSB4Timeout
5.2.2#3	TD 4.13.3	If the USB4 device additionally supports Alternate Modes, the device shall complete the USB4 discovery and entry process before falling back to USB 3.2 or USB 2.0 and exposing an appropriate USB Billboard Device Class.

Assertion #	Test Name	Assertion Description
5.2.3 USB4 Alternate Mode Support		
5.2.3.1 USB4 Alternate Mode Support on Hosts		
5.2.3.1#1	IOP	For USB4 hosts that implement DisplayPort Tunneling, DP Alt Mode with multi-functional support as defined by the DisplayPort Alt Mode specification shall be implemented on all of its USB Type-C DFPs.
5.2.3.1#2	IOP	The USB4 host shall support the first connected DisplayPort display on any of its USB Type-C ports.
5.2.3.2 USB4 Alternate Mode Support on Hubs and USB4-based Docks		
5.2.3.2#1	IOP	USB4 hubs and USB4-based docks shall implement DP Alt Mode with Multi-function support as defined by the DisplayPort Alt Mode specification on all of its USB Type-C DFPs.
5.2.3.2#2	IOP	USB4 hubs shall support the first connected DisplayPort display on any of its USB Type-C DFPs.
5.2.3.2#3	IOP	USB4-based docks shall support the first connected display on any of its USB Type-C DFPs or non-USB display connectors.
5.2.3.2#4	IOP	USB4 hubs shall implement TBT3 compatibility support as defined by the USB4 specification on its USB Type-C UFP and USB Type-C DFPs.
5.2.3.2#5	IOP	USB4-based docks shall implement TBT3 compatibility support as defined by the USB4 specification on its USB Type-C UFP and USB Type-C DFPs.
5.2.3.2#6	TD 4.13.1	For USB4 hubs, downstream-facing ports shall not implement Alternate Modes that do not have a USB-IF Standard ID (SID) or Accessory Mode.
5.3 USB4 Power Requirements		
5.3#1	TD 4.10.2	A USB4 port, prior to entering USB4 operation, shall operate as a USB 3.2 port with regard to power.
5.3.1 Source Power Requirements		
5.3.1#1	SPT	USB Type-C ports that support USB4 data operation shall be minimally capable of supplying at least 7.5W on Vbus to bus-powered USB4 devices.
5.3.1#2	SPT	The minimum capability for powering bus powered devices on data-capable ports shall be independently met on each USB Type-C port of a multi-port host or hub.
5.3.2 Sink Power Requirements		
5.3.2#1		USB4 devices that rely on bus power to operate shall draw only up to 250mA on Vbus when the Source advertises Default USB power

Assertion #	Test Name	Assertion Description
		prior to a USB PD power contract being made between the device and its port partner.
5.3.2#2	IOP	USB4 devices that rely on bus power to operate shall be minimally capable of operating with a Source that only delivers up to 7.5W
5.3.2#3	PD/IOP	USB4 devices that rely on bus power to operate shall not enter into USB4 data bus operation until after a USB PD power contract has been established, and while in USB4 operation, the device shall adhere to USB PD power behavioral requirements at all times including appropriately responding to changes in Source capabilities.
5.3.2#4	IOP	In cases where the full functional capabilities or the highest performance of the USB4 device requires more than the power being offered by the host, the device shall be minimally capable of providing the user with basic functionality as expected for the type and listed functions of the device.
5.3.2#5	IOP	In cases where the power offered by the host is enough for only basic functional capabilities, the device shall expose a Billboard that indicates functionality is limited by the available power.
5.3.3 Device Power Management Requirements		
5.3.3#1		When the USB Suspend Supported Flag is set by the Source, the Sink shall meet the Suspend power requirement when the USB4 link is in the CLd state.
5.3.3#2		If the Source clears the USB Suspend Supported Flag, the Sink shall follow Explicit Contract power requirements regardless of the USB4 link state.
5.4 USB4 Discover and Entry Flow Requirements		
5.4#1	BC TD 4.13.1 TD 4.13.2	Prior to entering and during USB4 operation, the functional requirements of Chapter 4 shall be met including all functional interface and configuration channel (CC) requirements.
5.4.1 USB Type-C Initial Connection		
5.4.1#1	BC TD 4.13.1 TD 4.13.2	For a USB4-capable port, prior to initiating USB4 cable and device discovery, a valid Source-to-Sink connection shall exist and the USB Type-C connection state machine of the port shall either be in the Attached.SRC or Attached.SNK state.
5.4.1#2	TD 4.13.1	Once the USB4 DFP completes the training of the links, it shall hold off on enabling the USB 3.2 and USB 2.0 enumeration of the attached UFP to allow for completion of the USB4 discovery and entry process.
5.4.2 USB Power Delivery Contract		
5.4.2#1	TD 4.13.1 TD 4.13.3	Prior to initiating USB4 device discovery, the port partners shall negotiate a USB PD Explicit Contract.

Assertion #	Test Name	Assertion Description
5.4.2#2	TD 4.13.1	Prior to USB4 discovery, the functional data role shall be properly established and the DFP shall be the source of Vconn.
5.4.3 USB4 Discovery and Entry Flow		
5.4.3.1 USB4 Device Discovery (SOP)		
5.4.3.1#1	TD 4.13.1	USB4 device discovery shall occur only after having a negotiated USB PD Explicit Contract
5.4.3.2 USB4 Cable Discover (SOP')		
5.4.3.2#1	TD 4.13.1	The DFP shall determine that the attached cable is USB4-compatible prior to entering into USB4 operation.
5.4.3.2#2	TD 4.13.2	In cases where the USB4 device is directly connected or has a captive cable, the USB4 device shall respond to USB4 cable discovery on SOP' as a captive passive cable and indicating the appropriate USB Signaling support.
5.4.3.2#3	TD 4.13.1	If no response is received when the DFP issues a USB PD Discover ID command to the cable, then the USB4 discovery process shall be exited and the DFP shall proceed to establish a functional connection to its UFP partner following traditional USB 2.0 process.
5.4.3.2.1 Discovering Passive Cables		
5.4.3.2.1#1	TD 4.13.1	If the USB signaling field in the Passive Cable VDO response is 000b, then the USB4 discovery process will be exited and the DFP shall proceed to establish a functional connection to its UFP port partner following traditional USB 2.0 process.
5.4.3.2.1#1	TD 4.13.1	If the USB signaling field in the Passive Cable VDO response is 010b and the DFP is capable of USB4 Gen 3 operation, then the DFP shall use the USB PD Alternate Mode process to determine if the cable also can be identified as a TBT3 Gen3 cable.
5.4.3.3 USB4 Operational Entry		
5.4.3.3#1	TD 4.13.1	USB4 operational entry shall occur only after having established that the attached cable, if present, and the port partner are USB4-capable.
5.4.3.3#2	TD 4.13.1	USB4 DFP shall send Enter_USB Message to SOP' first, SOP" second if present, and SOP third.
5.4.3.3#3	TD 4.13.1	When using the USB PD Enter_USB Message for enabling USB4 operation, the DFP shall indicate 010b in the USB Mode field of the Enter_USB Data Object, and the remaining fields shall be set appropriately based on the capabilities of the DFP and attached cable.
5.4.4 USB4 Post-Entry Operation		
5.4.4.2 Exiting USB4 Operation		

Assertion #	Test Name	Assertion Description
5.4.4.2#1	TD 4.13.3	As part of the Data Reset process, a port shall issue a USB PD Data_Reset command to the SOP port partner to reset the data bus, reset the cable, and exit any Alternate Modes while preserving the power on Vbus.
5.4.4.2#2	TD 4.13.4	The tUSB4Timeout and tAMETimeout timers within the UFP shall be reset upon sending or receiving a USB PD Data_Reset command.
5.4.4.2#3	TD 4.13.3	As part of the Data Reset process, the DFP shall re-enter the USB4 Discovery and Entry process.
5.5 USB4 Hub Connection Requirements		
5.5.2 USB4 Hub UFP and Host Capabilities Discovery		
5.5.2#1	Not Tested	If the USB4 hub's UFP is connected to an upstream USB4 hub, then the capabilities reported in the received USB PD Enter_USB message shall only be considered the host's capabilities if the Host Present bit is set.
5.5.2#2	Not Tested	If the received USB PD Enter_USB message's Host Present bit is reset, then the hub shall wait for a subsequent USB PD Enter_USB message to be received with the Host Present bit set.
5.5.2#3	Not Tested	If the USB4 hub's UFP receives an USB PD Enter_USB message which indicates the USB operation as either USB 3.2 or USB 2.0, the USB4 hub shall not wait for the completion of the tUSBTimeout before proceeding to establish its UFP and DFP connections following USB 3.2 or USB 2.0 hub requirements, respectively.
5.5.3 Hub DFP Connection Requirements		
5.5.3.2 Operational Connections		
5.5.3.2#1	Not Tested	Once the USB4 hub's UFP connection is established and the host capabilities are determined, for each DFP, if the DFP connection properly aligns with the capabilities of the UFP connection, enable the status notifications and data path for that port.
5.5.3.2#2	Not Tested	Once the USB4 hub's UFP connection is established and the host capabilities are determined, for each DFP, if the DFP connection does not properly align with the capabilities of the UFP connection and if the UFP remains in USB4 and the DFP connection is with a USB4 hub, send a revised USB PD Enter_USB message with the Host Present bit set.
5.5.3.2#3	Not Tested	Once the USB4 hub's UFP connection is established and the host capabilities are determined, for each DFP, if the DFP connection does not properly align with the capabilities of the UFP connection and if the UFP changed to USB 3.2 or USB 2.0 and the DFP connection is with a downstream USB4 hub, the DFP shall reset the connection using USB PD Data_Reset followed by sending a revised USB PD Enter_USB message indicating USB 3.2 or USB 2.0 and the Host Present bit set.

Assertion #	Test Name	Assertion Description
5.5.3.2#4	Not Tested	Once the USB4 hub's UFP connection is established and the host capabilities are determined, for each DFP, if the DFP connection does not properly align with the capabilities of the UFP connection and if the UFP does not have a USB4, USB 3.2 or USB 2.0 data connection or the DFP is not connected to a another USB4 hub UFP, the DFP shall enter the ErrorRecovery state to reset the connection and establish a new connection that aligns with the hub's UFP capabilities.
5.5.4 Hub Ports Connection Behavior Flow Model		
5.5.4#1	Not Tested	If the speculatively established connection turns out to be invalid, the DFP connection shall be reset and a connection that aligns with the hub's UFP capabilities shall be established.
5.5.4#2	Not Tested	After the USB 3.2 connection of the hub's UFP is established, the DFP connection to an Alt Mode device is no longer valid with the USB4 hub operating as a traditional USB 3.2 hub, so the hub's DFP shall then reset the port which will lead to a USB 2.0 connection and the exposure of the Billboard device.
5.5.5 Connecting to Downstream USB4 Hubs		
5.5.5#1	Not Tested	When a USB4 hub is attached on its DFP to the UFP of another USB4 hub, the USB4 hub shall use the Host Present bit of the USB PD Enter_USB message to inform the downstream hub if the USB4 capabilities listed in the message reflects the host's capabilities or not.
5.5.5#2	Not Tested	If an initial connection is made with the downstream hub with the Host Present bit reset in the USB PD Enter_USB message, the USB4 hub shall subsequently send a revised USB PD Enter_USB message with the Host Present bit set after its UFP has been fully established.
5.5.6 Fallback Functional Requirements for USB4 Hubs		
5.5.6#1	BC/IOP	When a USB4 hub is attached on its UFP to a non-USB4 DFP, the USB4 hub shall seamlessly fall back to functioning as and meeting the requirements for a USB 3.2 hub.
5.6 USB4 Device Connection Requirements		
5.6.1 Fallback Mapping of USB4 Peripheral Functions to USB Device Class Types		
5.6.1#1	IOP/CV	Each function of a USB4 device shall be mapped to an equivalent USB device class when possible.
5.6.1#2	IOP/CV	USB4 devices that contain mapped USB device class functions shall support operation at USB 3.2 or USB 2.0 when connected to non-USB4 hosts. (See Table 5-2 for required mapping)
5.6.1#3	TD 4.10.6	For all USB4 peripheral functions based on DisplayPort and PCIe protocol tunneling that do not map to USB device class equivalents when operating over USB 3.2 or USB 2.0, an appropriate USB Billboard Device Class shall be exposed to enable user notifications

Assertion #	Test Name	Assertion Description
		by the operating system of the host platform.
6 Active Cables		
6#1	4.14.1	Active cables shall minimally support USB 3.2 Gen 2x1 and may support USB 3.2 Gen 1x2 or Gen 2x2.
6#2	BC	Active cables shall support USB PD eMarkers and may support Alternate Modes and advertise them as defined in Section 6.7.
6#3	4.13.5	All USB4 active cables shall be interoperable with Thunderbolt 3 as defined in the USB4 Specification (Chapter 13) and this specification (Section 6.7 and Appendices E and F)
6#4	BC	Short active cables supporting lengths up to 5 meters shall work in both directions and orientations and should function like passive cables from the user's perspective.
6#7	USB Active Cable Test Matrix	All Active Cables, regardless of length, shall be compliant with this specification, the USB 3.2 including Appendix E, and the USB 3.2 Active Cable CTS.
6.2 USB PD Requirements		
6.2#1	Thermal	Active Cables temperature sensor shall be co-located with the repeater for accurate thermal reporting.
6.2#2	BC	An Active Cable that contains two repeaters shall support both SOP' and SOP"
6.2#3	BC	An Active Cable that only contains one repeater internal to the active cable (not in the cable plugs) shall implement SOP' and is not required to implement SOP"
6.2.1 Active Cable USB PD Requirements		
6.2.1#1	BC	Active cables shall support USB PD revision 3, Version 1.2 or later.
6.2.1#2	BC	Active cables shall support USB PD structured VDMs.
6.2.1.1 SOP' and SOP'' Requirements		
6.2.1.1#1	4.14.1	Active cables shall respond to Discover_Identity and Get_status on SOP'.
6.2.1.1#2	4.14.1	When the SOP" Controller Present bit is set in the Active Cable VDO, an Active Cable shall respond to Get_Status on SOP"
6.2.1.2 Discovering Cable Characteristics		
6.2.1.2#2	PD	All active cables shall respond to the Discover_Identity command with Active Cable VDOs that return information about the cable. Note the active cable shall respond using either USB PD Revision 2 or USB PD Revision 3 following the USB PD Interoperability rules.
6.2.1.3 Cable Status		

Assertion #	Test Name	Assertion Description
6.2.1.3#1	4.14.1	Cable status shall be reported on SOP' and shall also be reported on SOP" when the SOP" Controller Present bit is set in the Active Cable VDO
6.4 Active Cable Power Requirements		
6.4.1 Vbus Requirements		
6.4.1#1	EPC.2	Short active cables shall meet the limits of the IR Drop on Vbus and ground defined in Section 4.4.1.
6.4.1#2	EPC.2	Short active cables shall provide Vbus and support at least 3 A and optionally 5 A current.
6.4.4 Vconn Requirements		
6.4.4#1		Active Cables shall meet the Vconn sink requirement defined in Table 4-6 and Table 6-19 - Inrush Capacitance
6.4.4#3	4.14.4	Active Cables shall meet the Vconn sink requirement defined in Table 4-6 and Table 6-19 - USB 3.2 states power
6.4.4#4	4.14.1	Active Cables shall meet the Vconn sink requirement defined in Table 4-6 and Table 6-19 - tVconnDischarge
6.4.4#5	4.14.1	Active Cables shall meet the Vconn sink requirement defined in Table 4-6 and Table 6-19 - vVconnDischarge
6.4.4#6	4.14.1	Active Cables shall meet the Vconn sink requirement defined in Table 4-6 and Table 6-19 - vRaReconnect
6.4.4#7	Cabcon	Active Cables shall connect Vconn as shown in Figure 2-1 or Figure 2-2
6.4.4#8	BC	Short Active Cables shall be capable of being powered from Vconn from only one port.
6.5 Mechanical		
6.5#1	Cabcon	All Active cables shall meet the mechanical requirements defined in section 3.8
6.5.1 Thermal		
6.5.1.1 Thermal Shutdown		
6.5.1.1#1	Thermal	All active cables shall implement a temperature sensor and place the USB 3.2 signals in the eSS.Disabled state when the plug skin temperature reaches the maximum defined in Table 6-14.
6.5.1.1#2	Thermal	Active cables shall indicate they are in thermal shutdown in queried via the USB PD Get_Status command.
6.5.1.2 Maximum Skin Temperature		
6.5.1.2#1	Thermal	Active cable plug's skin temperature shall not exceed a maximum operating temperature of 30 degree C above the ambient temperature for a plastic/rubber housing and 15 degree C for a

Assertion #	Test Name	Assertion Description
		metal housing in any operating mode.
6.5.1.3 Thermal Reporting		
6.5.1.3#1	Thermal	Active Cables shall implement reporting their maximum internal operating temperature in the USB PD Discover_ID command.
6.5.1.3#2	Thermal	Active Cables shall implement reporting their current internal operating temperature in the USB PD Get_Status command on SOP' and SOP" when supported.
6.5.1.3#3	Thermal	Active Cables shall update their reported Internal Temperature at least every 500 ms.
6.5.1.3#4	Thermal	The plug's Internal Temperature is reporting in Celsius and shall be monotonic.
6.5.1.3#5	Thermal	It is not the plug's skin temperature, but cable manufacturers shall correlate the maximum internal operating temperature with the maximum plug skin temperature to ensure shutdown when the maximum plug skin temperature is reached.
6.6 Electrical Requirements		
6.6.1 Shielding Effectiveness Requirement		
6.6.1#1	Electrical	All active cables shall meet the Low-Speed Signal Requirements in Section 3.7.2.4.
6.6.2 Low Speed Signal Requirement		
6.6.2.2 SBU Requirements		
6.6.2.2.1 Short Active Cables		
6.6.2.2.1#1	EPC.3	Short active cables SBU wires shall meet the requirements defined in Table 6-15 and shall meet the crosstalk requirements both near-end and far-end between the low speed signals as defined in Section 3.7.2.4.
6.6.3 USB 2.0		
6.6.3.1 Short Active Cables		
6.6.3.1#1	Electrical	Short active cables shall meet the USB 2.0 requirements defined in Section 3.7.2.4 and 3.7.2.7
6.6.4 USB 3.2		
6.6.4#1	BC	Active cables shall meet the requirements in this section regardless of length.
6.6.4#2	Electrical	Active cables shall incorporate AC-coupling from the plug to repeater on both the USB 3.2 TX and RX signals.
6.6.4#3	Cabcon	Active cables shall provide a discharge path for discharging the AC-coupling capacitors in the cable on unplug per USB 3.2.

Assertion #	Test Name	Assertion Description
6.6.4.1 USB 3.2 Active Cable Architecture		
6.6.4.1#1	Cabcon	Active cables shall support the features defined in Table 6-2.
6.6.4.2 USB 3.2 Power-on and Rx.Detect		
6.6.4.2#1	4.1.3	Active cables shall present a high impedance to ground of Zrx-high-imp-dc-pos when not powered.
6.6.4.2#2	4.14.1	Active cables shall present a high impedance to ground of Zrd-high-imp-dc-pos at initial power-on.
6.6.4.2#3	4.14.1	The active cable shall perform far-end receiver termination detection on both ends upon receiving Vconn.
6.6.4.2#4	4.14.1	Upon detecting a far-end low-impedance receiver termination (Rrx-dc), the active cable shall enable its low-impedance receiver termination (Rrx-dc) to mirror the presence of the Host/Device.
6.6.4.2#5	4.14.4	The active cable shall perform far-end receiver termination detection for Repeaters per USB 3.2 including in low power states U2/U3.
6.6.4.2#6	4.14.1	An active cable shall complete power-on and far-end receiver termination detection through the cable within tFWD_RX.DETECT.
6.6.4.2#7	4.14.1	Active cables including OIACs shall reflect the receiver terminations across the cable to replicate the behavior of a passive cable.
6.6.4.3 USB 3.2 U0 Delay		
6.6.4.3#1	4.14.1	All active cables shall meet the USB 3.2 delay defined in Table 6-17.
6.6.4.4 USB 3.2 U-State Power Requirements		
6.6.4.4#1	4.14.4	Active cables shall meet the Vconn power requirements in Table 6-19.
6.6.4.5 USB 3.2 U-State Exit Latency		
6.6.4.5#1	4.14.4	Active cables shall meet the U-state exit latency defined in USB 3.2 Appendix E.
6.6.4.6 USB 3.2 Signal Swing		
6.6.4.6.1 TP1 – Active Cable Input Stressed Source		
6.6.4.6.1#2	Electrical	If any discrepancy exists between this specification and the USB 3.2 specification, the USB 3.2 specification shall take precedence.
6.6.4.6.1#3	Electrical	The maximum swing with the maximum de-emphasis and pre-shoot shall be tested with the minimum loss compliance test board.
6.6.4.6.1#4	Electrical	The minimum swing with the minimum de-emphasis and pre-shoot shall be tested with the maximum loss compliance test board.

Assertion #	Test Name	Assertion Description
6.6.4.6.1#5	Electrical	The active cable shall function over the range of parameter in USB 3.2 Table 6-17 and Table 6-20
6.6.4.6.4 TP4 – Active Cable Output		
6.6.4.6.4#4	Electrical	The active cable bit-error-rate shall be tested at TP4 and meet or exceed a BER of 1E-12.
6.6.4.6.4#5	Electrical	The error detector used shall have the ability to remove SKP ordered sets.
6.6.5 USB4		
6.6.5.1 Electrical Requirements That Apply to All Active Cable Types		
6.6.5.1.3 AC Coupling Capacitors		
6.6.5.1.3#1	Electrical	Active cables shall include AC-coupling capacitance between 135 nF and 265 nF inside their plugs placed at the output transmit path and between 300 nF and 363 nF at the input receive path.
6.6.5.1.3#2	Electrical	Discharge resistors between 200 KOhm and 242 KOhm shall be placed at the input receive path.
6.6.5.1.4 Differential Return-Loss Mask (Informative)		
6.6.5.1.4#1	Electrical	Re-timer and re-driver cable input and output return-loss measurements shall be referenced to a differential impedance of 85 Ohms.
6.6.5.2 Re-timer-based Active Cable Electrical Specifications		
6.6.5.2.1 Output Equalization		
6.6.5.2.1#1	Electrical	A USB4 active cable shall implement tunable 3-tap finite-impulse-response (FIR) equalization at its output.
6.6.5.2.4 Cable Error-Burst Testing		
6.6.5.2.4#1	Electrical	In order to facilitate proper FEC operation, an active cable receiver shall take steps to limit the probability that a burst of errors is restarted immediately after receiving one or more correct bits (see USB4 specification).
6.6.5.2.4#2	Electrical	The cable receiver under test shall trigger on bit-errors and shall capture error events that follow.
6.6.5.2.4#5	Electrical	The receiver under test shall trigger on bit-error and shall capture error events as follows.
6.6.5.2.4#6	Electrical	At least 32 consecutive bits shall be examined for errors starting from the initial trigger.
6.6.5.2.4#7	Electrical	The probability for burst renewal shall be 5E-7 or less (i.e. one error burst restart per 2 million error captures).
6.7 Active Cables That Support Alternate Modes		

Assertion #	Test Name	Assertion Description
6.7.1 Discover SVIDs		
6.7.1#1	4.14.3	Active cables that support an Alternate Mode shall report support for SVIDs on SOP' only.
6.7.2 Discover Modes		
6.7.2#1	4.14.3	Active cables that support an Alternate Mode shall report support for Modes on SOP' only.
6.7.3 Enter/Exit Modes		
6.7.3#1	4.14.3	Enter and Exit mode shall be communicated on SOP' and on SOP'' when the SOP'' Controller Present bit is set in the Active Cable.
6.7.4 Power in Alternate Modes		
6.7.4#1	Thermal	The power dissipation in an active cable's Alternate Mode shall maintain the plug's Maximum Skin Temperature below the requirement defined in Table 6-14.
E Alternate Modes		
E#1	4.28 4.36	All hosts and devices (except chargers) using a USB Type-C receptacle shall expose a USB interface.
E#2	4.28 4.36	When a host or device supports Alternate Modes, the host and device shall use USB Power Delivery Structured Vendor Defined Messages (Structured VDMs) to discover, configure and enter/exit modes to enable Alternate Modes
E#3	4.28 4.36	When a host or device supports Alternate Modes, where no equivalent USB functionality is implemented, the device shall provide a USB interface exposing a USB Billboard Device Class used to provide information needed to identify the device
E#4	4.40	As Alternate Modes do not traverse the USB hub topology, they shall only be used between a directly connected host and device.
E.1 Alternate Mode Architecture		
E.1#1	Untestable	Only Structured VDMs shall be used to alter the USB functionality or reconfigure the pins the USB Type-C Connector exposes.
E.2 Alternate Mode Requirements		
E.2#1	4.28 4.36	The host and device shall negotiate a USB PD Explicit Contract before Structured VDMs may be used to discover or enter an Alternate Mode.
E.2#2	4.36	The ACK shall be sent after switching to the Alternate Mode has been completed by the UFP for Enter Mode and Exit Mode requests.
E.2#3	4.36	If a device fails to successfully enter an Alternate Mode within tAMETimeout then the device shall minimally expose a USB 2.0 interface (USB Billboard Device Class) that is powered by VBUS.

Assertion #	Test Name	Assertion Description
E.2#4	4.36	If the device enters the mode after a host sends Enter Mode, it shall respond with an ACK and discontinue exposing the USB Billboard Device Class interface.
E.2#5	PD	The current supplied over VCONN may be redefined by a specific Alternate Mode but the power shall not exceed the current rating of the pin (See Section 3.7.7.4).
E.2.1 Alternate Mode Pin Reassignment		
E.2.1#1	4.28 4.36	Figure 5-1 illustrates the only pins that shall be available for functional reconfiguration in a full-featured cable.
E.2.1#2	4.28 4.36	The pins highlighted in yellow (Fig 5-1) are the only pins that shall be reconfigured.
E.2.1#3	4.28 4.36	Figure 5-2 illustrates the only pins that shall be available for functional reconfiguration in direct connect applications such as a cradle dock, captive cable or a detachable notebook.
E.2.1#4	4.28 4.36	The pins highlighted in yellow (Fig 5-2) are the only pins that shall be reconfigured.
E.2.2 Alternate Mode Electrical Requirements		
E.2.2#1	4.28 4.36	Signaling during the use of Alternate Modes shall comply with all relevant cable assembly, adapter assembly and electrical requirements of Chapter 3.
E.2.2#2	4.28 4.36	When operating in an Alternate Mode and pin pairs A2, A3 (TX1) and B2, B3 (TX2) are used, these shall be AC coupled in or before the plug.
E.2.2#3	4.28 4.36	Alternate Mode signals being received at the USB Type-C receptacle shall not exceed the value specified for VTX-DIFF-PP in Table 6-17 of the USB 3.1 specification.
E.2.2#4	4.28 4.36	When in an Alternate Mode, activity on the SBU lines shall not interfere with USB PD BMC communications or interfere with detach detection.
E.2.2#5	4.28	SBU1/2 and SSTX/SSRX must transition to the USB Safe State before entering to or exiting from an Alternate Mode.
E.2.2#6	4.28	The DFP and UFP shall provide a discharge path to ground in USB Safe State when a connection to the USB Type-C receptacle is present.
E.3 Parameter Values		
E.3#1	4.28 4.36	While operating in an Alternate Mode, the signaling shall not cause noise ingress onto USB signals operating concurrently that exceeds the Vnoise parameters given in Table 5-3.

Test Requirements

Hardware

The USB Type-C Connector Verification System (CVS) is a hardware solution capable of testing the verifications defined by this document. The CVS implements the following block diagram:

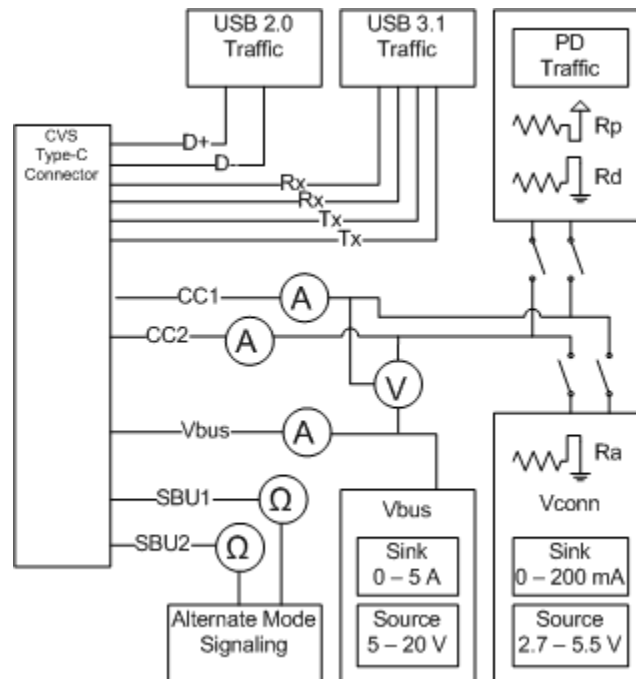

Figure 1: CVS Block Diagram

For a PUT bound to a USB Type-C receptacle, the CVS is required to emulate the USB Type-C Connector State Machines from the perspective of the PUT receptacle. So it must appear as the Source / Sink / SNKAS / DRP AND as the cable (R_a) at the same time. To accomplish this the CVS uses a special cable so that CVS hardware has access to both CC pins on a PUT receptacle. If the PUT is bound to a captive cable, then the test hardware emulates the USB Type-C Connector State Machines from the perspective of the captive cable connector, and does not emulate a cable at the same time.

The CVS must be able to measure voltage, current and resistance values as defined in the Electrical Requirements section.

Most tests require a test setup with one CVS system connected to the DUT. The CVS system must also be connected to a test operator's computer to run its software.

Cable tests require each plug end of the CUT to be plugged into a CVS system. Both CVS systems must be plugged into the test operator's computer to utilize its software. Additional connections may be necessary (for instance, between CVS1 and CVS2), please refer to the CVS documentation for details.

CVS1 – CUT – CVS2

The following tests require this tester setup:

TD 4.1.3

TD 4.13.5

TD 4.14.1-5

Electrical

The CVS determines PUT state by confirming that state's electrical requirements are detected. CC terminations R_p , R_d , and R_a and currents and voltages are defined in USB Type-C Spec Section 4.11.1 Termination Parameters and 4.11.3 Voltage Parameters. V_{BUS} values are defined by the USB Type-C spec as well all the USB 2.0 and USB 3.1 specifications, USB BC 1.2, and USB Power Delivery specification depending on the context. V_{BUS} current is defined by USB Type-C Specification. V_{CONN} is defined by the USB Type-C spec and USB PD specification. The CVS verifications check against these defined values to confirm PUT state.

Measurement implementations are up to the tester HW vendor. The following Figure shows an example of a SBU resistance measurement implementation on a CVS tester.

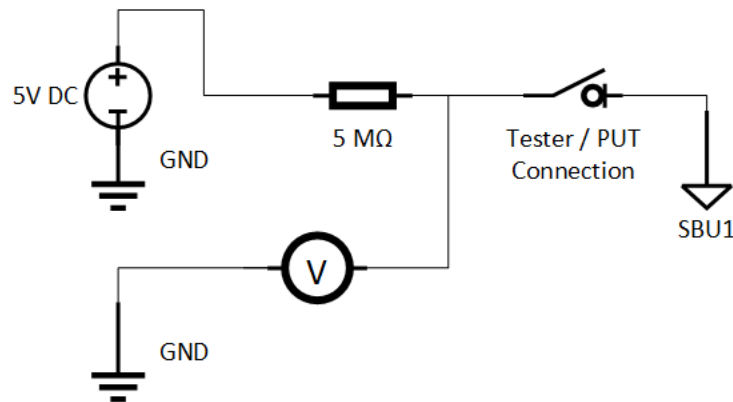

Figure 2: Example SBU Resistance Measurement Methodology

Timing

Transitions between states and other timers are defined in USB Type-C Spec Section 4.11.2 Timing Parameters. The CVS verifications check against these defined values to confirm PUT transitions.

In addition to those parameters defined in the table, there are some clarifying points and additional timers defined below:

1) DRP PUT transition to Attached state

The time from CVS transition to Unattached state to when CVS can verify one of:

- 1) PUT transitions to Attached.SNK
- 2) PUT transitions to Attached.SRC

is:

$$t_{DRP.DRPAttach} = 5 \times t_{DRP}$$

2) PUT transition out of Attached.SRC

The PUT transition from Attached.SRC or PoweredAccessory to Unattached.SNK or Unattached.SRC is immediate as defined in the USB Type-C Specification. But the PUT has $t_{VbusOFF}$ or $t_{VconnOFF}$ to stop sourcing V_{bus} and

Vconn (USB Type-C Spec Section 4.11.2). So for those transitions, the PUT may be sourcing Vbus or Vconn while in the Unattached.SNK or Unattached.SRC state. This is the only scenario where a PUT would be sourcing those voltages while in Unattached.SNK or Unattached.SRC, and the reader may note this is an exception to the spec requirement that those voltages are not sourced while in those states (USB Type-C Spec Sections 4.5.2.2.3.1 Unattached.SNK Requirements & 4.5.2.2.6.1 Unattached.SRC Requirements).

Although the spec defines the transition out of Attached.SRC or PoweredAccessory to be immediate when Rd is no longer detected, due to low clock speed on the CC pins and power saving implementations the PUT may not detect Rd has been removed for more than 2 ms. If USB PD is implemented on the product, it may be retrying a message and postponing far-end detection for more than 12ms.

For the purposes of Compliance testing we have given the PUT a timer of tDetach to make the transition.

tDetach = max tPDDebounce = 20ms

3) PUT transition out of Attached.SNK

When a PUT transitions from Attached.SNK to Unattached.SNK or Unattached.SRC, it must make the transition immediately upon detecting removal of Vbus. This can be immediate and may take up to tVbusOFF.

Product VIF

There are a few testing requirements based on the USB-C Product implementation.

The Vendor Info File (VIF) is used in conjunction with test software to indicate PUT product implementation. This file can be generated by the following tool:

<http://www.usb.org/developers/tools/#PDFfile>

Note: The VIF may be generated by test equipment vendors as well.

This sections lists VIF fields that are used or implicated in the USB Type-C Functional Test descriptions and gives a brief summary of how they are used.

VIF_PRODUCT_TYPE

This field is used as an applicability criteria for every test. If VIF_Product_Type is set to 0, then CVS checks fields related to all port tests. If VIF_Product_Type is set to 1 or 2, then CVS checks fields related to cable tests. When running Type-C Functional testss when VIF_Product_Type is set to 2, many of the test results may rely on or be affected by the product packaging, and using a development board is a considerable variable in meeting the requirements of these tests.

Type_C_State_Machine
Type_C_Implements_Try_SRC
Type_C_Implements_Try_SNK
Type_C_Supports_Audio_Accessory
Type_C_Supports_VCONN_Powered_Accessory
Type_C_Is_Vconn_Powered_Accessory

Type_C_Is_Debug_Target_SNK Type_C_Is_Debug_Target_SRC

These fields' values are used in Connection Tests to determine applicability. Source Connection tests are only applicable when Type_C_State_Machine = 0 (SRC). Type_C_State_Machine is used in several Source-Capable or Sink-Capable Tests to constrain applicability as well.

Type_C_Can_Act_As_Host Type_C_Can_Act_As_Device Host_Speed Device_Speed

These fields' values are used in various tests to determine whether the PUT supports USB 3.1 or USB 2.0 and at what speed. With this information, the CVS will know which data conditions from the test description are applicable for the test run. A test step might refer to a PUT that supports USB 3.1 as a host. This is equivalent to Type_C_Can_Act_As_Host = YES and Host_Speed = 1.

USB_PD_Support

This field is used to ascertain whether the PUT supports PD. When its value is set to YES, USB PD is supported. If USB_PD_Support is set to YES and Type_C_Can_Act_As_Host = YES then the Data_Capable_as_USB_Host_SOP field must also be set to YES in the VIF. Similarly, if Type_C_Can_Act_As_Device = YES then the Data_Capable_As_USB_Device_SOP field must be YES.

PD_Port_Type

PD_Port_Type is used to determine whether Source-Capable or Sink-Capable Tests are applicable. If the value is in the set {0: Consumer Only, 1: Consumer/Provider, 2: Provider/Consumer, 4: DRP}, then the Sink-Capable Tests are required. If the value is set to one of {1: Consumer/Provider, 2: Provider/Consumer, 3: Provider Only, 4: DRP}, then the Source-Capable Tests are required.

For USB-IF Certification, a Provider/Consumer or Consumer/Provider with Type_C_State_Machine set to SRC or SNK are discouraged. These product schemes will limit a product's ability to connect with its link partner and creates a silent failure. The failure scenarios include the connection between a SNK which supports PR_Swap and a dead battery device.

Captive_Cable

The VIF field Captive_Cable set to NO indicates the PUT is a PUT_R, and the value YES indicates PUT is a PUT_C. More information about PUT_R and PUT_C is in the Tests section.

Rp_Value

If the VIF field Type_C_State_Machine is set to 0 (SRC) or 2 (DRP) then the PUT has an Rp pull up resistor on its CC pins. The value of this resistor indicates the Type-C Current level that the PUT can source. The value here indicates the PUT Rp resistor value on Attach.

Port_Battery_Powered

This field is used in TD 4.11.2 Sink Dead Battery Test, checking that a DUT with a Dead Battery implements a USB Type-C Sink State Machine.

If the DUT uses a Battery then it must run the Type-C Functional Tests once with a charged battery and again with a Dead Battery.

Compliance Rev 0.91

Type_C_Port_On_Hub

This field is used in TD Section 4.12 Hub tests.

Type_C_Power_Source

If the DUT is capable of being a UFP-powered device or an Externally-powered device (including charge-through), then the DUT must run Type-C Functional Tests with both connection scenarios. As a UFP-powered device, the DUT must implement a USB Type-C Sink Connection state machine.

Type_C_BC_1_2_Support

This field is used to determine if the PUT supports BC 1.2 and whether it is supported as a Source, as a Sink, or both. If the DUT is capable of sinking via USB BC 1.2 protocol, then its usage will be exercised during TD 4.10.2 Sink Power Precedence Test.

Type_C_Sources_Vconn

This field is used to determine if the PUT is a PUT_V and will be tested again Vconn requirements. Some PUTs are required to source Vconn as described in the PUT_V definition in the Tests section of this document. When a PUT is not required to source Vconn, it still may support doing so and in that case is still held to the Vconn requirements in the spec.

DR_Swap_To_DFP_Supported

DR_Swap_To_UFP_Supported

These fields are used in TD 4.11.1 DR_Swap Test to ascertain which directions to test. Usage described in the test steps.

If the VIF fields indicate either of the following:

- USB_PD_Support is NO and Type_C_State_Machine is DRP
- Type_C_Can_Act_As_Host is YES and Type_C_Can_Act_As_Device is YES

Then at least one of the fields DR_Swap_To_DFP_Supported or DR_Swap_To_UFP_Supported must be YES.

VCONN_Swap_To_On_Supported

VCONN_Swap_To_Off_Supported

These fields are used in TD 4.9.4 Source Vconn_Swap Test and TD 4.10.5 Sink Vconn_Swap Test to ascertain which directions to test. Usage described in the test steps.

Modal_Operation_Supported_SOP

Attempts_Discov_SOP

These fields are used in TD 4.9.5 Source Alternate Modes Test and TD 4.10.6 Sink Alternate Mode Test to ascertain which directions to test. Usage described in the test steps.

Accepts_PR_Swap_As_Src

Accepts_PR_Swap_As_Snk

These fields are used in TD 4.9.3 Source PR_Swap Test and TD 4.10.4 Sink PR_Swap Test to ascertain which directions to test. Usage described in the test steps.

USB4_DFP_Supported
USB4_UFP_Supported
USB4_PCl_e_Tunneling_Supported
US4_DP_Tunneling_Supported
USB4_TBT3_Compatibility_Supported

These fields are used in TD 4.13.1 DFP Enter_USB Test, TD 4.13.2 UFP Enter_USB Test, TD 4.13.3 Data Reset Test and TD 4.13.4 to discover what tests and checks are required. Usage described in the test steps.

USB4_Supported

This field is used in TD 4.13.5 Cable EnterUSB and Data Reset Test to discover whether the test is required.

Cable_USB_Highest_Speed
Cable_Termination_Type
Cable_SOP_PP_Controller
Product_Type
Modal_Operation_Supported
Active_Cable_USB_Lanes

These fields are used in TD 4.1.3, TD 4.13.5, and TDs 4.14.x Cable tests to determine whether the cable is Passive or Active, whether it supports entering/exiting Alternate Modes, whether SOP” messaging is required and what USB speed to emulate during tests.

Product Test Requirements

Different product types are required to run different Type-C Functional tests. This section lists tests required based on overall port / plug type. This section can be used as a guideline and test applicability rules are also determined by other characteristics within product type below. For specific test applicability based on port configuration and implementation options, check each test's applicability section.

Emarker:
TD 4.13.6

Cable:
TD 4.1.3
TD 4.13.5
TD 4.14.x

Port without USB4 Support:
TD 4.1.1-2
TD 4.2.x (SRC)
TD 4.3.x (SNK)
TD 4.4.x (SNKAS)
TD 4.5.x (DRP without Try states)
TD 4.6.x (DRP with Try.SRC)
TD 4.7.x (DRP with Try.SNK)
TD 4.8.x (DRP)
TD 4.9.x (Source capable)
TD 4.10.x (Sink capable)
TD 4.11.x
TD 4.12.x (Hub)

Ports with USB4 Support:
All applicable tests for ports without USB4 Support
TD 4.13.x

Tests

See Appendix B for information about the USB-IF Test Results schema and the Verification [TD4.x.x.V.x] and [DATA.V.x] and Condition [TD.4.x.x.C.x] tags.

PUT Tests

Many test steps require the CVS to emulate states defined in the USB Type-C Connection State machines. In the attached state this includes appropriate responses to capabilities messages and cable discovery as needed. During steps that require messaging, the CVS default behavior is to reject unexpected swap messages.

State emulation is accomplished slightly differently when the CVS is testing a PUT bound to a USB Type-C receptacle (PUT_R) vs. a PUT bound to a USB Type-C captive cable or a direct attach (PUT_C).

For a PUT_R, the CVS will apply the CC values indicated by a Type-C Connection State on only one CC pin. Note: for a test run, the one CC pin stays the same throughout the test. The other pin, unless otherwise indicated, remains in an Open state. The test steps will indicate if the other CC pin will be terminated with Ra. If the other CC pin is terminated with Ra, the CVS will apply the following cable identity. Some fields may be changed from the below outline as indicated in a Test Condition or Step:

Default ID Header Fields:

Modal Operation Supported: 0b

SOP' Product Type: 011b (Passive Cable)

Default Passive Cable VDO Fields:

USB Highest Speed: 011b (USB4 Gen3)

Vbus Current Handling Capability: 10b (5A)

Maximum Vbus Voltage: 11b (50V)

Cable Termination Type: 00b (Vconn not required)

Cable Latency: 0001b (< 10ns)

EPR Mode Capable: 1b

USB Type-C plug to USB Type-C/Captive: 10b (USB Type-C)

If a Test Condition or Step describes applying an Active Cable identity, the CVS will apply the following cable identity. Some fields may be changed from the below outline as indicated in a Test Condition or Step:

Default ID Header Fields:

Modal Operation Supported: 0b

SOP' Product Type: 100b (Active Cable)

Compliance Rev 0.91

Default PD 3.x Active Cable VDO Fields:

USB Highest Speed: 011b (USB4 Gen3)
SOP” Controller Present: 0 (No)
Vbus Through Cable: 1
Vbus Current Handling Capability: 10b (5A)
SBU Type: 1 (SBU is Active)
SBU Supported: 0
Maximum Vbus Voltage: 11b (50V)
Cable Termination Type: 10b (One end Active)
Cable Latency: 0001b (<10ns)
EPR Mode Capable: 1
USB Type-C Plug to USB Type-C/Captive: 10b (USB Type-C)
USB Gen: 1b
Optically Isolated Active Cable: 0b
USB Lanes Supported: 1b
USB 3.2 Supported: 0b
USB 2.0 Supported: 0b
USB 2.0 Hub Hops Consumed: 1
USB4 Supported: 0b
Active Element: 1b
Physical Connection: 0b
U3 to U0 Transition Mode: 0b
U3/CLd Power: 000b
Shutdown Temperature: 80C
Maximum Operating Temperature: 60C

Default PD 2.0 Active Cable VDO Fields:

USB SuperSpeed Signaling Support: 010b (USB 3.1 Gen 2)
SOP” Controller Present: 0 (No)
Vbus Through Cable: 1
Vbus Current Handling Capability: 10b (5A)
SSRX2 Directionality Support: 0
SSRX1 Directionality Support: 0
SSTX2 Directionality Support: 0
SSTX1 Directionality Support: 0
Cable Termination Type: 10b (One end Active)
Cable Latency: 0001b (<10ns)
USB Type-C plug to USB Type-A/B/C/Captive: 10b (USB Type-C)

For a PUT_C, the CVS will apply the CC values indicated by a Type-C Connection State on both CCs and monitors the CCs to ascertain to which CC the PUT is connected.

For instance, when a test step indicates that the CVS transitions to Unattached.SRC:

- For a PUT_R, the CVS will apply Rp on one CC and unless otherwise indicated, the other CC pin will remain in an Open state. The test step will indicate if the other CC pin will be terminated with Ra.
- For a PUT_C, the CVS will apply Rp on both CCs.

When a test step indicates that the CVS apply Rp, unless otherwise indicated, the Rp advertises the USB default current.

For tests that verify load on Vbus, the CVS will give a 5 ms delay starting at Vbus ON (Vbus enters vSafe5V range) for inrush allowance before measuring current.

When a test step indicates it is verifying data communications:

- For USB 3.1 data communications, the tester verifies U0 is reached between CVS and PUT [DATA.V.1]
- For USB 2.0 data communications, the tester verifies packets received from PUT [DATA.V.2]
- If the step is testing a port connected as a UFP and test condition refers to USB 2.0 data:
 - If VIF field USB4_Supported is YES and the tester did not send an Enter_USB message, the tester verifies PUT connects its D+/D- terminations after 1s (tUSB4Timeout) and before 2s from Vbus ON [DATA.V.10]
 - If VIF field USB4_Supported is YES and the tester did send an Enter_USB message, the tester verifies PUT connects its D+/D- terminations within 1s after receiving a GoodCRC in reply to the Enter_USB message. [DATA.V.11]
 - If VIF field USB4_Supported is not YES and VIF field Type_C_Is_Alt_Mode_Adapter is YES, the tester verifies 1.5s from Vbus ON for the PUT to connect its D+/D- terminations [DATA.V.3]
 - If VIF field USB4_Supported is not YES and VIF field Type_C_Is_Alt_Mode_Adapter is NO, the tester verifies 1s from Vbus ON for the PUT to connect its D+/D- terminations [DATA.V.4]
 - The tester verifies that the PUT applies terminations after Vbus on [DATA.V.5]
- If the step is testing a port connected as a UFP and test condition refers to USB 3.x data:
 - If VIF field USB4_Supported is YES and the tester did not send an Enter_USB message, the tester verifies PUT connects its eSS terminations after 1s (tUSB4Timeout) and before 2s from Vbus ON [DATA.V.6]
 - If VIF field USB4_Supported is YES and the tester did send an Enter_USB message, the tester verifies PUT connects its eSS terminations within 1s after receiving a GoodCRC in reply to the Enter_USB message. [DATA.V.7]
 - If VIF field USB4_Supported is not YES and VIF field Type_C_Is_Alt_Mode_Adapter is YES, the tester verifies 1.5s from Vbus ON for the PUT to connect its eSS terminations [DATA.V.8]
 - If VIF field USB4_Supported is not YES and VIF field Type_C_Is_Alt_Mode_Adapter is NO, the tester verifies 1s from Vbus ON for the PUT to connect its eSS terminations [DATA.V.9]
- For tests that include USB 3.x data communications test steps, the tester will present data terminations for the duration of the test. This ensures that timing verifications are tested in a stress situation.

The following paragraphs describe the assumed initial testing state for a PUT_R and PUT_C.

For a PUT_R, every test is initialized with the following assumptions:

1. CVS starts in Disabled
2. PUT and CVS are physically connected through a cable.
3. The cable connecting the CVS and PUT has a through connection on both CC pins so the CVS can emulate a cable. This is so the CVS can generate and monitor VCONN sourcing and sinking

For a PUT_C, every test is initialized with the following assumptions:

1. CVS starts in Disabled
2. PUT and CVS are physically connected through the PUT captive cable.

A PUT will always be either a PUT_R or a PUT_C. In addition to that, the PUT will also be categorized as a PUT_V if it supports sourcing Vconn in the Attached.SRC state. A test step will indicate when a verification is only checked for a PUT_V.

If a PUT is a PUT_R and indicates point 1 and either 2 or 3 below:

1. VIF field Type_C_State_Machine is set to SRC or DRP or PD_Port_Type is Consumer/Provider
2. VIF field Type_C_Host_Speed is USB 3.1 or Type_C_Device_Speed is USB 3.1 indicating PUT supports USB 3.1 signaling on its SS RX and SS TX pairs
3. VIF indicates any Source PDO with Max Current greater than 3A

Then the PUT is required to be capable of sourcing Vconn and shall also be referred to as a PUT_V in this document.

If a PUT has VIF field `Type_C_Port_On_Hub` set to YES and `Type_C_Can_Act_As_Host` set to YES, then CVS prompts the user to verify the UFP of the hub under test is plugged into a host.

CPUT Tests

For testing a CPUT the test setup includes two HW units. The tester HW used to emulate a Host is called the CVSh and the tester HW used to emulate a Device is called the CVSD. The CPUT is connected between them. For other details in test setup refer to the tester vendor's documentation. Normally CVSh and CVSD are both plugged into a test machine running the CVS test software, and CVSh and CVSD are plugged into each other for timestamp sync.

For a CPUT, every test is initialized with the following assumptions:

1. CVSh and CVSD starts in Disabled (i.e. no terminations present)
2. CVSh, CPUT and CVSD are physically connected.

For a CPUT, whenever a test Condition or test steps indicate that data communications will be present for the test, CVSh and CVSD apply data terminations when CVSh and CVSD enter attached states and cease signaling and remove data terminations on a CVS that enters Disabled.

For a CPUT test, when far-end terminations are detected, CVSh enumerates CVSD and the link remains active with emulated bulk data transmission. CVS will use the highest USB speed that the tester supports if it is not as high as `Cable_USB_Highest_Speed`. This communication is triggered and maintained until another test step indicates a state change:

- Behavior triggered at the following steps:
 - CVSh and CVSD transition to Attached states
 - CVSh and CVSD also present data terminations
 - CVSh and CVSD exit a low power state
 - CVSh reset signal completion
- State change indicated at the following steps:
 - CVSh / CVSD transitions to Disabled
 - CVSh / CVSD removes data terminations
 - CVSh transitions to Unattached.SRC
 - CVSh removes data terminations
 - CVSh / CVSD detects far-end terminations removed
 - CVSh / CVSD transitions to Rx.Detect / SE0
 - CVSh and CVSD complete LGO_Ux handshake
 - CVSh and CVSD enter Ux state
 - CVSh transmits reset signal
 - CVSh and CVSD transition to Rx.Detect or SE0

A TBT3 compatible LRD Active Cable uses a workaround for backward compatibility with TBT hosts. It will indicate in a Discover Identity response that it is a Passive Cable (Product Type set to 011b) but it is an Active Cable and is beholden to Active Cable requirements. Whenever a CPUT test applicability section or test step indicates it is applicable for an Active Cable (the step language will use VIF field Product Type set to 100b or Active Cable), the step is also applicable for a cable with the following VIF field values and values as found in its Discover Identity / Discover SVIDs / Discover Modes response:

- Product Type set to 011b (Passive Cable)
- Cable Termination Type set to 01b (Vconn Required)

- Modal Operation set to YES
- TBT3 Alternate Mode SVID present in an SVID<X> field (an SVID<X> value is set to 0x8087)
- SVID<X>_Mode1_Recog_Value B25 is set to 1 (TBT3 Discover Mode response indicating Active Cable)

The applicable verification steps for a TBT3 compatible LRD Active Cable applicable excludes steps referring to VIF fields describing Cable VDO fields that are only present in Active Cable VDO 1 or Active Cable VDO 2, and verification test steps checking the ID Header Product Type field, which will be set to 011b in this case.

Connection Tests

All USB Type-C Connectors participate in the Initial Voltage Test, TD 4.1. The rest of the Connection Tests check the CC initialization sequence between possible USB Type-C implementations. Tests are categorized by the type of Connection State Machine they implement in USB Type-C Spec Section 4.5.2.1 Connection State Diagrams and for the Accessories section, for a lack of Connection State Machine.

TD 4.1.1 Initial Voltage Test

- A. Purpose:
 1. An unconnected PUT that is not a charger with a captive cable does not source voltage/current on its CC pins.
 2. Verify Source – Source connection does no damage
- B. Applicability:
 1. This test applies to all USB Type-C Ports, indicated with VIF field VIF_Product_Type field set to 0 (Port Product).
- C. Asserts:
 1. 4.3#1
 2. 4.4.2#2,4
 3. 4.5.1.2#1,2
 4. 4.5.2.2.1#1
 5. 4.5.2.2.1.1#1

6. 4.5.2.2.6.2#3
7. 4.5.2.2.13.1#1
8. 4.8.1.1#1
9. 4.8.1.2#1
10. 4.6#5

D. Procedure:

1. If the PUT sources Vbus:
 - a. CVS Verifies:
 - i. VIF field USB_PD_Support is set to NO [TD.4.1.1.V.2]
 - ii. VIF field Type_C_State_Machine is set to SRC [TD.4.1.1.V.3]
 - iii. VIF field Captive_Cable is set to YES [TD.4.1.1.V.4]
 - iv. VIF field Type_C_Can_Act_As_Host is set to NO [TD.4.1.1.V.5]
 - v. VIF field Type_C_Can_Act_As_Device is set to NO [TD.4.1.1.V.6]
 - b. If the VIF fields in step 2.a are all verified, the test is over. The only other applicable Type_C_Functional test is TD 4.9.2.
2. CVS verifies that the VBUS pins do not source VBUS (4.5.2.2.1#1) [TD.4.1.1.V.7]
3. For a Source-capable PUT:
 - a. CVS transitions to Unattached.SRC state.
 - b. Wait 750ms.
 - c. CVS verifies PUT does not source VBUS (4.5.1.2#2) [TD.4.1.1.V.8]
 - d. For a PUT_R:
 - i. CVS transitions to Disabled for 750ms.
 - ii. CVS terminates 1 CC pin with Ra.
 - iii. Wait 750ms.
 - iv. CVS verifies PUT does not source VBUS [TD.4.1.1.V.9]
 - v. CVS verifies PUT does not source VCONN (4.5.2.2.6.2#3) [TD.4.1.1.V.10]
 - e. CVS transitions to Disabled for 750ms.
4. For a Sink and SNKAS PUT:
 - a. CVS transitions to Unattached.SNK state for 50ms
 - b. CVS transitions to Unattached.Accessory state for 50ms
 - c. CVS transitions to Unattached.SNK state for 50ms
 - d. CVS transitions to Disabled for 750ms.
5. For a Sink-capable PUT:
 - a. CVS applies USB 3.1/2.0 DFP terminations
 - b. Wait 2s
 - c. CVS verifies PUT did not apply D+ pull-up or SS terminations [TD.4.1.1.V.11]
6. CVS applies 53.2k resistance from Vbus to CC pin.
7. CVS verifies PUT does not source Vbus after tCCDebounce. [TD.4.1.1.V.12]
8. CVS removes 53.2k resistance from Vbus to CC pin.
9. CVS presents VBUS for 1s.
10. This test must be performed before the DUT is tested at the USB-IF Interoperability Test Suites.

TD 4.1.2 Unpowered CC Voltage Test

A. Purpose:

1. Verify that a product which is powered off does not present R_d

B. Applicability:

1. This test applies when VIF field Type_C_State_Machine is SRC

2. This test applies when VIF field Type_C_State_Machine is DRP and Port_Battery_Powered is NO.
 3. This test applies when VIF field Type_C_State_Machine is SNK and Type_C_Power_Source is 0 (“Externally Powered”) and Port_Battery_Powered is NO.
- C. Asserts:
1. TBD
- D. Procedure:
1. If Type_C_State_Machine is DRP, CVS verifies that Type_C_Power_Source is not set to 1 (UFP-Powered) [TD.4.1.2.V.1]
 2. CVS prompts the user to unplug external power to the product so that the PUT is unpowered
 3. CVS applies Rp in the USB Default Current range
 4. If Type_C_State_Machine is DRP and Type_C_Power_Source is 2 (Both), CVS verifies that PUT applies Rd and does not toggle. [TD.4.1.2.V.2]
 5. Else, CVS verifies that CC voltage is in vOPEN range [TD.4.1.2.V.3]
 6. CVS transitions to Disabled for 500ms
 7. CVS applies Rp in the USB Type-C Current 1.5 A range
 8. If Type_C_State_Machine is DRP and Type_C_Power_Source is 2 (Both), CVS verifies that PUT applies Rd and does not toggle. [TD.4.1.2.V.4]
 9. Else, CVS verifies that CC voltage is in vOPEN range [TD.4.1.2.V.5]
 10. CVS transitions to Disabled for 500ms
 11. CVS applies Rp in the USB Type-C Current 3.0 A range
 12. If Type_C_State_Machine is DRP and Type_C_Power_Source is 2 (Both), CVS verifies that PUT applies Rd and does not toggle. [TD.4.1.2.V.6]
 13. Else, CVS verifies that CC voltage is in vOPEN range [TD.4.1.2.V.7]
 14. CVS prompts the test operator to replug external power to the product so that the PUT is powered

TD 4.1.3 Unpowered Cable Test

- A. Purpose:
1. Check CPUT works when it is not powered
- B. Applicability:
1. This test is applicable for all CPUTs
- C. Asserts
1. 4.5.2.4.1.1#2
 2. 4.5.2.4.2.1#6
 3. 4.9#4,8
 4. 6.6.4.2#1
- D. Conditions:
1. CVS1 is CVSh, acts as Type-C SRC / USB 2.0 DFP / no Vconn Source port. CVS2 is CVSD, acts as Type-C SNK / USB 2.0 UFP [TD.4.1.3.C.1]
 2. CVS2 is CVSh, acts as Type-C SRC / USB 2.0 DFP / no Vconn Source port. CVS1 is CVSD, acts as Type-C SNK / USB 2.0 UFP [TD.4.1.3.C.2]
- E. Procedure:
1. CVSh and CVSD transition to Unattached.SRC and Unattached.SNKAttached
 2. CVS verifies:
 - a. vRa is present on first CVSh far-end detect and throughout the test [TD.4.1.3.V.1]

- b. If VIF field Product_Type is 4 (Active Cable), CPUT presents Zrx-high-imp-dc-pos throughout the test [TD.4.1.3.V.2]
 3. CVS transitions to Attached states after tCCDebounce, starts PD messaging and USB data. CVSh sends Discover ID on SOP' and GetStatus on SOP''.
 4. CVS verifies:
 - a. CVSh and CVSD are able to complete a 5V 3 A Fixed PDO contract. [TD.4.1.3.V.4]
 - b. CPUT does not respond on SOP' or SOP'' [TD.4.1.3.V.5]
 - c. CVSh enumerates CVSD at USB 2.0 without issue and maintains bulk traffic transfer for 500ms [TD.4.1.3.V.6]

Source Tests

These tests are for USB Type-C connectors that implement the Source connection state machine in USB Type-C Specification Figure 4-12.

TD 4.2.1 Source Connect Sink Test

- A. Purpose:
 1. Verify a Source transitions to Attached.SRC according to spec
 2. Verify a Source transitions to Unattached.SRC when Sink removed
- B. Applicability:
 1. This test applies when VIF field Type_C_State_Machine is SRC
- C. Asserts:
 1. 4.4.2#1-3
 2. 4.5.2.2.6.1#1-3
 3. 4.5.2.2.6.2#1
 4. 4.5.2.2.7.1#1-3
 5. 4.5.2.2.7.2#1,5
 6. 4.5.2.2.8.1#2,4-10
 7. 4.5.2.2.8.2#1
 8. 4.6.2.1#3
 9. 4.6.2.4#1,2
- D. Conditions:
 1. CVS emulates a SNK receptacle connector [TD.4.2.1.C.4]
 2. CVS emulates USB PD 2.0 5A Active Cable [TD.4.2.1.C.1]
 3. CVS emulates USB PD 3.0 5A Active Cable [TD.4.2.1.C.2]
 4. CVS emulates USB4 re-driver cable (ID Header Product Type = Passive, Cable VDO indicate Vconn required, TBT3 SVID / Mode supported and mode indicates Active Cable) [TD.4.2.1.C.3]
- E. Procedure:
 1. If VIF field Captive_Cable is set to YES, CVS emulates a receptacle as per condition 1 in Section D above, otherwise CVS emulates an Active cable as per condition 2
 2. CVS verifies PUT does not apply Rd for the remainder of the test (Note: This is to check for toggling between Rd/Rp for connect) [TD.4.2.1.V.1]
 3. If VIF field Type_C_Sources_Vconn is NO, CVS verifies PUT does not source Vconn for the remainder of this test. [TD.4.2.1.V.2]
 4. CVS transitions to Unattached.SNK.
 5. For a PUT_R:
 - a. CVS terminates one CC pin with Ra for the duration of the test.
 - b. CVS verifies PUT has transitioned to Unattached.SRC

- i. PUT applies Rp simultaneously on both CC pins [TD.4.2.1.V.3]
 - c. CVS waits 80ms
 - d. CVS transitions to Disabled except for one CC maintaining Ra
 - e. CVS verifies PUT transitions to Unattached.SRC [TD.4.2.1.V.4]
 - f. Wait 750ms.
 - g. CVS transitions to Unattached.SNK
- 6. CVS verifies that:
 - a. CVS detects SNK.Rp on its Rd terminated CC pin [TD.4.2.1.V.5]
 - b. PUT transitions to Attached.SRC by sourcing VBUS after tCCDebounce and before tCCDebounce + tVBUSON expires after CVS detects SNK.Rp [TD.4.2.1.V.6]
- 7. Vconn_tested = false
- 8. If PUT supports USB PD:
 - a. CVS verifies that:
 - i. PUT stabilizes VBUS before initiating USB PD communications [TD.4.2.1.V.7]
 - ii. CVS and PUT negotiate a contract. [TD.4.2.1.V.8]
 - b. If PUT source capabilities include a Max Current > 3 A:
 - i. CVS verifies that for a PUT_R, it supplied Vconn within tVconnON [TD.4.2.1.V.9]
 - ii. Vconn_tested = true
- 9. If PUT supports USB 3.1 DFP:
 - a. CVS verifies that:
 - i. PUT attaches eSS terminations before Vbus on or within 80ms of Vbus on [TD.4.2.1.V.10]
 - ii. For a PUT_R and not Vconn_tested:
 - 01 It supplied VCONN within tVCONN [TD.4.2.1.V.11]
 - 02 Vconn_tested = true
 - iii. PUT transmits LFPS within 121ms of attaching eSS terminations OR transmits Warm Reset within 2s of attaching eSS terminations [TD.4.2.1.V.12]
 - iv. After eSS terminations are applied, and prior to PD Enter Mode negotiation if applicable, the SBU pins on the PUT are within zSBUTermination [TD.4.2.1.V.13]
 - b. CVS loads 1W on Vconn
 - c. Wait 1s
- 10. If the PUT is a PUT_V and not Vconn_tested:
 - a. CVS verifies that for a PUT_R, it supplied Vconn within tVconnON [TD.4.2.1.V.14]
- 11. CVS transitions to Disabled
- 12. CVS verifies that PUT transitions to Unattached.SRC within tSRCDisconnect
 - a. PUT removes Vbus within tVbusOFF [TD.4.2.1.V.15]
 - b. For a PUT that supports USB 3.1 DFP, Vconn was sourced until after step 10 [TD.4.2.1.V.16]
 - c. All signaling has stopped [TD.4.2.1.V.17]
- 13. CVS waits 1 second, checking that PUT does not toggle
- 14. If VIF field Captive_Cable is NO, the CVS continues the test with step 2, using the next Condition from section D above

TD 4.2.2 Source Connect SNKAS Test

A. Purpose:

1. Verify a Source transitions to Attached.SRC according to spec when link partner is Sink with Accessory Support (SNKAS).
- B. Applicability:
 1. This test applies when VIF field Type_C_State_Machine is SRC
- C. Asserts:
 1. See TD 4.2 Asserts.
 2. 4.5.2.2.7.2#4
- D. Procedure:
 1. CVS transitions to Unattached.SNK for 5ms.
 2. CVS transitions to Unattached.Accessory for max dcSRC.DRP x max tDRP.
 3. CVS verifies Source is in Unattached.SRC:
 - a. For a PUT_R, both CCs advertise Rp [TD.4.2.2.V.1]
 - b. For a PUT_C, the CC connected to Rd advertises Rp [TD.4.2.2.V.2]
 4. CVS transitions to Unattached.SNK
 5. CVS verifies that the PUT:
 - a. Advertises VBUS capabilities with Rp throughout the test [TD.4.2.2.V.3]
 - b. Sources VBUS after tCCDebounce deadline and before tCCDebounce + VBUSON expires. [TD.4.2.2.V.4]

TD 4.2.3 Source Connect DRP

- A. Purpose:
 1. Verify a Source transitions to Attached.SRC according to spec
- B. Applicability:
 1. This test applies when VIF field Type_C_State_Machine is SRC
- C. Asserts:
 1. 4.4.2#1-3
 2. 4.5.2.2.6.1#1-3
 3. 4.5.2.2.6.2#1
 4. 4.5.2.2.7.1#1-3
 5. 4.5.2.2.7.2#1
 6. 4.5.2.2.8.1#2,4-6
- D. Procedure:
 1. CVS transitions to Unattached.SNK for 1.5 ms
 2. CVS transitions to Unattached.SRC for max dcSRC.DRP x min tDRP
 3. CVS transitions to Unattached.SNK
 4. CVS verifies the PUT is in Unattached.SRC providing Rp [TD.4.2.3.V.1]
 5. CVS verifies the PUT transitions to Attached.SRC after tCCDebounce expires:
 - a. PUT sources VBUS within tVBUSON [TD.4.2.3.V.2]
 - b. If PUT supports USB PD:
 - i. CVS and PUT negotiate an explicit contract [TD.4.2.3.V.3]

TD 4.2.4 Source Connect Try.SRC DRP

- A. Purpose:
 1. Verify a Source transitions to Attached.SRC according to spec
- B. Applicability:
 1. This test applies when VIF field Type_C_State_Machine is SRC
- C. Asserts:
 1. TBD

- D. Procedure:
1. CVS transitions to Unattached.SNK for 10 ms
 2. CVS transitions to Unattached.SRC for 50 ms
 3. CVS transitions to Unattached.SNK
 4. CVS verifies the PUT is in Unattached.SRC providing Rp [TD.4.2.4.V.1]
 5. CVS transitions to AttachWait.SNK for tCCDebounce max
 6. CVS verifies the PUT transitions to Attached.SRC [TD.4.2.4.V.2]
 7. CVS transitions to Try.SRC
 8. CVS verifies the PUT transitions to Unattached.SRC
 - a. PUT has removed Vbus within tVbusOff [TD.4.2.4.V.3]
 - b. PUT has ceased all clocked signaling [TD.4.2.4.V.4]
 9. If Vbus is not within vSafe0V after max tDRPTry from step 7, wait min tTryTimeout from step 7
 10. CVS transitions to TryWait.SNK
 11. CVS verifies the PUT and CVS transitions to Attached.SRC and Attached.SNK after tCCDebounce expires:
 - a. PUT sources VBUS within tVBUSON [TD.4.2.4.V.5]
 - b. If PUT supports USB PD:
 - i. CVS and PUT negotiate an explicit contract [TD.4.2.4.V.6]
 - c. Note PUT may transition to Attached.SRC and back to Unattached.SRC before time expires

TD 4.2.5 Source Connect Try.SNK DRP

- A. Purpose:
1. Verify a Source transitions to Attached.SRC according to spec
- B. Applicability:
1. This test applies when VIF field Type_C_State_Machine is SRC
- C. Asserts:
1. TBD
- D. Procedure:
1. CVS transitions to Unattached.SNK for 1.5 ms
 2. CVS transitions to Unattached.SRC for min dcSRC.DRP x min tDRP
 3. CVS transitions to Unattached.SNK
 4. CVS verifies the PUT is providing Rp [TD.4.2.5.V.1]
 5. CVS verifies the PUT transitions to Attached.SRC after tCCDebounce expires:
 - a. PUT sources VBUS within tVBUSON [TD.4.2.5.V.2]
 - b. If PUT supports USB PD:
 - i. CVS and PUT negotiate an explicit contract [TD.4.2.5.V.2]

TD 4.2.6 Source Connect Audio Accessory

- A. Purpose:
1. Verify a Source that supports Audio Accessories connects according to spec requirements
- B. Applicability:
1. This test applies for a PUT_R when VIF field Type_C_State_Machine is SRC and Captive_Cable is NO
- C. Asserts:
1. 4.5.2.2.7.2#2
 2. 4.5.2.2.15.1#1,2,4,5
 3. 4.5.2.2.15.2#2
- D. Procedure:
1. CVS presents Audio Accessory CC terminations with Ra

2. CVS verifies PUT provides Rp on both CCs (PUT in Unattached.SRC) [TD.4.2.6.V.1]
3. If VIF field Type_C_Supports_Audio_Accessory is YES:
 - a. CVS verifies PUT transitions to AudioAccessory after tCCDebounce:
 - i. The PUT reconfigures its pins as defined in Appendix A [TD.4.2.6.V.2]
 - ii. The PUT does not drive VBUS or VCONN [TD.4.2.6.V.3]
 - iii. If the PUT sinks current over VBUS, it shall not be more than 500mA [TD.4.2.6.V.4]
 - iv. The PUT applies Rp on at least one CC [TD.4.2.6.V.5]
4. If VIF field Type_C_Supports_Audio_Accessory is NO:
 - a. CVS verifies PUT does not transition to Attached.SRC or supply Vbus [TD.4.2.6.V.6]
5. CVS transitions to Disabled
6. If VIF field Type_C_Supports_Audio_Accessory is YES:
 - a. CVS verifies PUT transitions to Unattached.SRC after tCCDebounce [TD.4.2.6.V.7]

TD 4.2.7 Source Connect Debug Accessory

- A. Purpose:
 1. Verify a Source that supports Debug Accessories does source Vbus
- B. Applicability:
 1. This test applies for a PUT_R when VIF field Type_C_State_Machine is SRC and Captive_Cable is NO
- C. Asserts
 1. 4.5.2.2.16.1#2
- D. Procedure:
 1. CVS presents DTS (Debug and Test System) Sink with Rds on both CCs
 2. CVS verifies PUT provides Rp on both CCs (PUT in Unattached.SRC) [TD.4.2.7.V.1]
 3. If VIF field Type_C_Is_Debug_Target_SRC is YES:
 - a. CVS verifies PUT sources Vbus after tCCDebounce and within tVbusON. [TD.4.2.7.V.2]
 4. Else If VIF field Type_C_Is_Debug_Target_SRC is NO or not defined:
 - a. CVS verifies PUT does not source Vbus after tCCDebounce expires [TD.4.2.7.V.3]

TD 4.2.8 Source Connect VCONN Accessory

- A. Purpose:
 1. Verify the Source connects with an Accessory that uses VCONN.
- B. Applicability:
 1. This test is applicable for a PUT_R with VIF field Type_C_State_Machine set to SRC and Captive_Cable is NO and Type_C_Sources_Vconn is YES
- C. Asserts:
 1. 4.5.2.2.8.1#10
 2. 4.5.2.2.8.2#6
 3. 4.5.2.2.19.1#5
- D. Procedure:
 1. CVS presents a Vconn-powered Accessory by terminating one CC with Rd and one CC with Ra.
 2. CVS verifies that:

- a. PUT transitions to Attached.SRC by sourcing VBUS after tCCDebounce and before tCCDebounce + tVBUSON expires [TD.4.2.8.V.1]
- b. PUT advertises VBUS capability over Rp [TD.4.2.8.V.2]
- c. PUT_V sources VCONN within tVCONNON [TD.4.2.8.V.3]
- d. For a PUT with PD (VIF field USB_PD_Support set to YES):
 - i. PUT initiates a PD Explicit Contract [TD.4.2.8.V.4]
 - ii. For a PUT with VIF field Attempts_Discov_SOP set to YES:
 - 1 PUT initiates Alternate Mode discovery with Structured VDMs [TD.4.2.8.V.5]
3. CVS transitions to Disabled
4. CVS verifies:
 - a. PUT stops sourcing VCONN within tVCONNOFF [TD.4.2.8.V.6]
 - b. PUT stops sourcing VBUS within tVBUSOFF [TD.4.2.8.V.7]

Sink Tests

These tests are for USB Type-C connectors that implement the USB Type-C Sink Connection State Diagram in Figure 4-14.

TD 4.3.1 Sink Connect Source Test

- A. Purpose:
 1. Verify a Sink transitions to Attached.SNK according to spec
 2. Verify that removing VBUS transitions the PUT to Unattached.SNK
- B. Applicability:
 1. This test applies when VIF field Type_C_State_Machine is SNK and Type_C_Supports_Audio_Accessory is NO and Type_C_Supports_VCONN_Accessory is NO.
- C. Asserts:
 1. 4.5.2.2.3.1#1-2
 2. 4.5.2.2.3.2#1
 3. 4.5.2.2.4.1#1-2
 4. 4.5.2.2.4.2#3
 5. 4.5.2.2.5.1#2-3,5-6
 6. 4.5.2.2.5.2#1
- D. Procedure:
 1. CVS verifies the PUT does not apply Rp for the remainder of the test. [TD.4.3.1.V.1]
 2. CVS transitions to Unattached.SRC
 3. For a PUT_R, CVS terminates one CC pin with Ra in any state other than Disabled for the remainder of the test.
 4. CVS verifies PUT presents Rd for tCCDebounce [TD.4.3.1.V.2]
 5. CVS transitions to Attached.SRC
 6. CVS verifies that PUT transitions to Attached.SNK:
 - a. If PUT data connection before PD contract, verify PUT sinks current according to CVS advertisement. [TD.4.3.1.V.3]
 - b. If PUT supports PD:
 - i. PUT and CVS negotiate an explicit contract. [TD.4.3.1.V.4]
 - c. If PUT supports USB 3.1 UFP:
 - i. PUT starts data communications on its SuperSpeed pairs. [TD.4.3.1.V.5]

- ii. After eSS terminations are applied, and prior to PD Enter Mode negotiation if applicable, the SBU pins on the PUT are within zSBUTermination [TD.4.3.1.V.6]
 - d. Else if PUT supports USB 2.0 UFP:
 - i. PUT starts data communications on its D+/D- pair [TD.4.3.1.V.7]
 - e. For a PUT_R, VCONN is not supplied [TD.4.3.1.V.8]
- 7. CVS transmits Discover ID PD messaging for 200ms.
- 8. CVS verifies that PUT:
 - a. If USB_PD_Support is YES:
 - i. Responds with valid GoodCRC messages. [TD.4.3.1.V.9]
 - ii. If Responds_To_Discov_SOP is YES:
 - 01 Transmits valid Responder ACK messages. [TD.4.3.1.V.10]
 - b. Remains in Attached.SNK during and for 500ms after step 6. [TD.4.3.1.V.11]
- 9. CVS programs Vbus source to meet 3.7V at the PUT connector.
- 10. CVS verifies PUT remains in Attached.SNK.
 - a. PUT maintains Rd on its CC [TD.4.3.1.V.12]
 - b. For a PUT that supports USB 3.2 or USB 2.0 signaling, the data signaling is maintained. [TD.4.3.1.V.13]
- 11. CVS removes Rps. CVS USB 2.0 and USB 3.1 signaling behaves as though it is in Attached.SRC as long as PUT is in Attached.SNK.
- 12. CVS decreases Vbus voltage by 0.1V.
 - a. Wait 100ms
 - b. If PUT removes Rd, or a PUT that supports USB 3.2 or USB 2.0 signaling ceases signaling, or Vbus source voltage is below 800mV, continue to step 13
 - c. Continue to step 12
- 13. CVS verifies that all data signaling ceases [TD.4.3.1.V.14]
- 14. CVS applies Rp
- 15. If Vbus is below 800 mV, continue to step 18
- 16. CVS verifies PUT remains in AttachWait.SNK for 500ms [TD.4.3.1.V.15]
- 17. CVS removes Vbus source
- 18. CVS transitions to Disabled
- 19. CVS verifies that PUT transitions to Unattached.SNK before tVBUSOFF expires:
 - a. PUT data communication has ceased. [TD.4.3.1.V.16]
- 20. CVS waits 1 second

TD 4.3.2 Sink Connect DRP Test

- A. Purpose
 - 1. Verify a Sink transitions to Attached.SNK according to spec
- B. Applicability:
 - 1. This test applies when VIF field Type_C_State_Machine is SNK and Type_C_Supports_Audio_Accessory is NO and Type_C_Supports_VCONN_Accessory is NO.
- C. Asserts:
 - 1. 4.5.2.2.3.1#1-2
 - 2. 4.5.2.2.3.2#1
 - 3. 4.5.2.2.4.1#1-2
 - 4. 4.5.2.2.4.2#1,3
 - 5. 4.5.2.2.5.1#2-3,5-6
 - 6. 4.5.2.2.5.2#1
- D. Procedure:
 - 1. CVS transitions to Unattached.SRC for 5ms

2. CVS transitions to Unattached.SNK for 30ms
3. CVS transitions to Unattached.SRC
4. CVS verifies PUT continued to provide Rd on the CC pin for the duration of steps 1-3 and for tCCDebounce after [TD.4.3.2.V.1]
 - a. For a PUT_R, verify this for both CC pins
5. CVS transitions to Attached.SRC
6. CVS verifies that PUT transitions to Attached.SNK:
 - a. PUT sinks current according to CVS advertisement [TD.4.3.2.V.2]
 - b. If PUT supports USB 3.1 UFP:
 - i. PUT starts data communications on its SuperSpeed pairs. [TD.4.3.2.V.3]
 - c. Else if PUT supports USB 2.0 UFP:
 - i. PUT starts data communications on its D+/D- pair [TD.4.3.2.V.4]
 - d. For a PUT_R, VCONN is not applied [TD.4.3.2.V.5]
7. CVS transitions to Disabled
8. CVS verifies that PUT transitions to Unattached.SNK before tVBUSOFF expires
 - a. PUT data communication has ceased [TD.4.3.2.V.6]
 - b. PUT is not sourcing Vbus (Vbus is at vSafe0V) [TD.4.3.2.V.7]
 - c. PUT is not sourcing Vconn [TD.4.3.2.V.8]

TD 4.3.3 Sink Connect Try.SRC DRP Test

- A. Purpose
 1. Verify a Sink transitions to Attached.SNK according to spec
- B. Applicability:
 1. This test applies when VIF field Type_C_State_Machine is SNK and Type_C_Supports_Audio_Accessory is NO and Type_C_Supports_VCONN_Accessory is NO.
- C. Asserts:
 1. TBD
- D. Procedure:
 1. CVS transitions to Unattached.SRC for 5ms
 2. CVS transitions to Unattached.SNK for 30ms
 3. CVS transitions to Unattached.SRC
 4. CVS verifies PUT continued to provide Rd on the CC pin for the duration of steps 1-3 and for tCCDebounce after [TD.4.3.3.V.1]
 - a. For a PUT_R, verify this for both CC pins
 5. CVS transitions to Attached.SRC
 6. CVS verifies that PUT transitions to Attached.SNK:
 - a. PUT sinks current according to CVS advertisement [TD.4.3.3.V.2]
 - b. If PUT supports USB 3.1 UFP:
 - i. PUT starts data communications on its SuperSpeed pairs. [TD.4.3.3.V.2]
 - c. Else if PUT supports USB 2.0 UFP:
 - i. PUT starts data communications on its D+/D- pair [TD.4.3.3.V.3]
 - d. For a PUT_R, VCONN is not applied [TD.4.3.3.V.4]
 7. CVS transitions to Disabled
 8. CVS verifies that PUT transitions to Unattached.SNK before tVBUSOFF expires
 - a. PUT data communication has ceased [TD.4.3.3.V.5]
 - b. PUT is not sourcing Vbus (Vbus is at vSafe0V) [TD.4.3.3.V.6]
 - c. PUT is not sourcing Vconn [TD.4.3.3.V.7]

TD 4.3.4 Sink Connect Try.SNK DRP Test

- A. Purpose
 - 1. Verify a Sink transitions to Attached.SNK according to spec
- B. Applicability:
 - 1. This test applies when VIF field Type_C_State_Machine is SNK and Type_C_Supports_Audio_Accessory is NO and Type_C_Supports_VCONN_Accessory is NO.
- C. Asserts:
 - 1. TBD
- D. Procedure:
 - 1. CVS transitions to Unattached.SRC for 5ms
 - 2. CVS transitions to Unattached.SNK for 30ms
 - 3. CVS transitions to Unattached.SRC
 - 4. CVS verifies PUT continues to provide Rd on the CC pin for the duration of this test [TD.4.3.4.V.1]
 - a. For a PUT_R, verify Rd is provided on both CC pins until Attached, and then on at least one CC for the duration of this test.
 - 5. CVS transitions to AttachWait.SRC for max tCCDebounce
 - 6. CVS transitions to Try.SNK for max tDRPTry + max tCCTryDebounce
 - 7. CVS transitions to TryWait.SRC for max tCCTryDebounce
 - 8. CVS transitions to Attached.SRC
 - 9. CVS verifies that PUT transitions to Attached.SNK:
 - a. PUT sinks current according to CVS advertisement [TD.4.3.4.V.2]
 - b. If PUT supports USB 3.1 UFP:
 - i. PUT starts data communications on its SuperSpeed pairs. [TD.4.3.4.V.3]
 - c. Else if PUT supports USB 2.0 UFP:
 - i. PUT starts data communications on its D+/D- pair [TD.4.3.4.V.3]
 - d. For a PUT_R, VCONN is not applied [TD.4.3.4.V.4]
 - 10. CVS transitions to Disabled
 - 11. CVS verifies that PUT transitions to Unattached.SNK before tVBUSOFF expires
 - a. PUT data communication has ceased [TD.4.3.4.V.5]
 - b. PUT is not sourcing Vbus (Vbus is at vSafe0V) [TD.4.3.4.V.6]
 - c. PUT is not sourcing Vconn [TD.4.3.4.V.7]

TD 4.3.5 Sink Connect SNKAS Test

- A. Purpose:
 - 1. Verify a Sink VCONN Powered Accessory configures an Alternate Mode when VCONN is present
- B. Applicability:
 - 1. This test is required when VIF field Type_C_State_Machine is SNK and Type_C_Is_VCONN_Powered_Accessory is set to YES.
- C. Asserts:
 - 1. 4.10#1-4

D. Procedure:

1. CVS does not present Vbus for the duration of this test.
2. CVS presents VCONN to the PUT CC pin terminated with Ra
3. CVS and PUT negotiate a PD Explicit Contract
4. CVS initiates negotiations for an Alternate Mode (Discover ID, SVIDs and Modes)
5. CVS verifies PUT supports an Alternate Mode [TD.4.3.5.V.1]
6. CVS initiates an Enter Mode command with a PUT supported Mode
7. CVS verifies:
 - a. PUT follows all electrical constraints for SBU and any reconfigured pins (i.e. USB Safe States). [TD.4.3.5.V.2]
 - b. PUT sends ACK for Enter Mode [TD.4.3.5.V.3]
8. CVS initiates an Exit Mode command for the active mode
9. CVS verifies:
 - a. PUT follows all electrical constraints for SBU and any reconfigured pins (i.e. USB Safe States). [TD.4.3.5.V.4]
 - b. PUT sends ACK for Exit Mode after successfully exiting the mode. [TD.4.3.5.V.5]
10. CVS removes VCONN
11. CVS verifies PUT transitions to Unattached.SNK within tVCONNOFF
 - a. All clocked signaling ceases [TD.4.3.5.V.6]

TD 4.3.6 Sink Connect Accessories Test

A. Purpose

1. Verify a Sink PUT does not interact with Accessories.

B. Applicability:

1. This test is required when VIF field Type_C_State_Machine is SNK and Type_C_Supports_Audio_Accessory is NO and Type_C_Supports_VCONN_Accessory is NO

C. Asserts

- 1.

D. Procedure

1. CVS applied Rd to both CCs.
2. CVS verifies no activity on the DUT. [TD.4.3.6.V.1]
3. CVS applied Ra to both CCs.
4. CVS verifies no activity on the DUT. [TD.4.3.6.V.2]
5. CVS applies Rd and Ra on CC1 and CC2.
6. CVS verifies no activity on the DUT. [TD.4.3.6.V.3]

SNKAS Tests

These tests are for USB Type-C Connectors that implement the USB Type-C Sink with Accessory Support (SNKAS) Connection State Diagram in Figure 4-15

TD 4.4.1 SNKAS Connect Source Test

- A. Purpose
 1. Verify a SNKAS PUT transitions to Attached.SNK according to spec
- B. Applicability
 1. This test is required when VIF field Type_C_State_Machine is SNK and Type_C_Supports_Audio_Accessory or Type_C_Supports_VCONN_Powered_Accessory is YES.
- C. Asserts
 1. See TD 4.8
- D. Procedure
 1. CVS transitions to Unattached.SRC.
 2. For a PUT_R, CVS terminates one CC pin with Ra for the duration of the test.
 3. CVS and PUT transition through the Type-C Connection State Machines to Attached.SRC and Attached.SNK
 4. CVS verifies PUT transitions to Attached.SNK after tCCDebounce and before tCCDebounce + (dcSRC.DRP x tDRP) expires.
 - a. PUT sinks current according to CVS advertisement [TD.4.4.1.V.1]
 - b. If PUT supports USB 3.1 UFP:
 - i. PUT starts data communications on its SuperSpeed pairs. [TD.4.4.1.V.2]
 - ii. After eSS terminations are applied, and prior to PD Enter Mode negotiation if applicable, the SBU pins on the PUT are within zSBUTermination [TD.4.4.1.V.3]
 - c. Else if PUT supports USB 2.0 UFP:
 - i. PUT starts data communications on its D+/D- pair [TD.4.4.1.V.4]
 - d. For a PUT_R, VCONN is not applied [TD.4.4.1.V.5]
 5. CVS transmits Discover ID PD messaging for 200ms.
 6. CVS verifies that PUT:
 - a. If USB_PD_Support is YES:
 - i. Responds with valid GoodCRC messages. [TD.4.4.1.V.6]
 - ii. If Responds_To_Discov_SOP is YES:
 - 01 Transmits valid Responder ACK messages. [TD.4.4.1.V.7]
 - b. Remains in Attached.SNK during and for 500ms after step 5.
 7. CVS programs Vbus source to meet 3.7V at the PUT connector.
 8. CVS verifies PUT remains in Attached.SNK.
 - a. PUT maintains Rd on its CC [TD.4.4.1.V.8]
 - b. For a PUT that supports USB 3.2 or USB 2.0 UFP, the data signaling is maintained. [TD.4.4.1.V.9]
 9. CVS removes Rps. CVS USB 2.0 and USB 3.1 signaling behaves as a DFP in Attached.SRC as long as PUT is in Attached.SNK.
 10. CVS decreases Vbus voltage by 0.1V.
 - a. Wait 100ms
 - b. If PUT removes Rd, or a PUT that supports USB 3.2 or USB 2.0 UFP ceases signaling, or Vbus source voltage is below 800mV, continue to step 11
 - c. Continue to step 10
 11. CVS verifies that all data signaling ceases [TD.4.4.1.V.10]
 12. CVS applies Rp
 13. CVS verifies that PUT transitions to AttachWait.SNK within tDRP
 - a. PUT applies Rd on its CC [TD.4.4.1.V.11]
 14. If Vbus is below 800 mV, continue to step 17
 15. CVS verifies PUT remains in AttachWait.SNK for 500ms [TD.4.4.1.V.12]
 16. CVS removes Vbus source

17. CVS transitions to Disabled
18. CVS verifies that PUT transitions to Unattached.SNK before tVBUSOFF expires
 - a. PUT data communication has ceased. [TD.4.4.1.V.13]
 - b. PUT is cycling between Unattached.SNK and Unattached.Accessory. [TD.4.4.1.V.14]

TD 4.4.2 SNKAS Connect DRP Test

- A. Purpose:
 1. Verify a SNKAS PUT transitions to Attached.SNK correctly with DRP
 2. Verify transition to Attached.SNK succeeds given varying measurements of tDRP and dcSRC.DRP
- B. Applicability
 1. This test is required when VIF field Type_C_State_Machine is SNK and Type_C_Supports_Audio_Accessory or Type_C_Supports_VCONN_Powered_Accessory is YES.
- C. Asserts:
 1. See TD 4.9
 2. 4.5.2.2.13.2#3
- D. Conditions on CVS DRP:
 1. tDRP = 50ms, dcSRC.DRP = 30% [TD.4.4.2.C.1]
 2. tDRP = 75ms, dcSRC.DRP = 30% [TD.4.4.2.C.2]
 3. tDRP = 100ms, dcSRP.DRP = 30% [TD.4.4.2.C.3]
 4. tDRP = 50ms, dcSRC.DRP = 50% [TD.4.4.2.C.4]
 5. tDRP = 75ms, dcSRC.DRP = 50% [TD.4.4.2.C.5]
 6. tDRP = 100ms, dcSRC.DRP = 50% [TD.4.4.2.C.6]
 7. tDRP = 50ms, dcSRC.DRP = 70% [TD.4.4.2.C.7]
 8. tDRP = 75ms, dcSRC.DRP = 70% [TD.4.4.2.C.8]
 9. tDRP = 100ms, dcSRC.DRP = 70% [TD.4.4.2.C.9]
- E. Procedure:
 1. CVS uses Condition 1 above for tDRP and dcSRC.DRP
 2. CVS transitions to Unattached.SNK for 5ms
 3. CVS transitions to Unattached.SRC for (dcSRC.DRP x tDRP). If this test step is reached more than once after step 1:
 - a. CVS monitors CCs for Rd and transitions to AttachedWait.SRC when it is detected
 - b. If Rd is present for longer than tCCDebounce, CVS transitions to Attached.SRC. Continue to step 5.
 4. CVS transitions to Unattached.SNK for tDRP – (dcSRC.DRP x tDRP).
 - a. If the PUT has reached step 4 less than 5 times since step 1, transition to step 3.
 - b. Else, the test fails. [TD.4.4.2.V.1]
 5. CVS verifies PUT transitions to Attached.SNK before 5 x tDRP expires.
 - a. PUT sinks no more Vbus current than CVS advertisement [TD.4.4.2.V.2]
 - b. If PUT supports USB 3.1 UFP:
 - i. PUT starts data communications on its SuperSpeed pairs. [TD.4.4.2.V.3]
 - c. Else if PUT supports USB 2.0 UFP:
 - i. PUT starts data communications on its D+/D- pair. [TD.4.4.2.V.4]
 - d. For a PUT_R, VCONN is not applied [TD.4.4.2.V.5]
 6. CVS transitions to Disabled
 7. CVS verifies that PUT transitions to Unattached.SNK before tVBUSOFF expires
 - a. PUT data communication has ceased [TD.4.4.2.V.6]

- b. PUT is cycling between Unattached.SNK and Unattached.Accessory.
[TD.4.4.2.V.7]
8. Continue at Step 1 with the next Condition

TD 4.4.3 SNKAS Connect Try.SRC DRP Test

- A. Purpose:
 1. Verify a SNKAS PUT transitions to Attached.SNK correctly with DRP
 2. Verify transition to Attached.SNK succeeds when its port partner uses Try.SRC
- B. Applicability
 1. This test is required when VIF field Type_C_State_Machine is SNK and Type_C_Supports_Audio_Accessory or Type_C_Supports_VCONN_Powered_Accessory is YES.
- C. Asserts:
 1. See TD 4.9
 2. 4.5.2.2.13.2#3
- D. Procedure:
 1. CVS attaches Ra on one of its CCs for the duration of the test
 2. CVS transitions to Unattached.SRC for 5ms
 3. CVS transitions to Unattached.SNK and starts timer max dcSRC.DRP x max tDRP (70ms).
 4. CVS monitors CCs for Rp and verifies that Rp is connected before the timer expires.
[TD.4.4.3.V.1]
 5. CVS transitions to AttachWait.SNK for max tCCDebounce.
 6. CVS verifies that Vbus is not detected after tCCDebounce. [TD.4.4.3.V.2]
 7. CVS remains in AttachWait.SNK and starts tAMETimeout
 8. CVS verifies that PUT attaches Rds (transitions to Try.SNK) before tAMETimeout expires [TD.4.4.3.V.3]
 9. CVS transitions through Unattached.SRC to AttachWait.SRC after min tPDDebounce.
 10. CVS transitions to Attached.SRC after max tCCDebounce
 11. CVS verifies that PUT transitions to Attached.SNK:
 - a. If PUT supports USB PD:
 - i. PUT and CVS establish an explicit contract [TD.4.4.3.V.4]
 - b. If PUT supports USB data:
 - i. PUT starts USB communication on its SS or D+/D- pairs.
[TD.4.4.3.V.5]

TD 4.4.4 SNKAS Connect Try.SNK DRP Test

- A. Purpose:
 1. Verify a SNKAS PUT transitions to Attached.SNK correctly with DRP
 2. Verify transition to Attached.SNK succeeds when its port partner uses Try.SNK
- B. Applicability
 1. This test is required when VIF field Type_C_State_Machine is SNK and Type_C_Supports_Audio_Accessory or Type_C_Supports_VCONN_Powered_Accessory is YES.
- C. Asserts:
 1. See TD 4.9

2. 4.5.2.2.13.2#3
- D. Procedure:
1. CVS applies Ra to one CC for the duration of the test
 2. CVS transitions to Unattached.SNK for 5ms
 3. CVS transitions to Unattached.SRC and starts timer max dcSRC.DRP x max tDRP (70ms).
 4. CVS monitors CCs for Rd and verifies that Rd is connected before the timer expires.
 5. CVS transitions to AttachWait.SRC for tCCDebounce.
 6. CVS transitions to Try.SNK and starts tDRPTry
 7. CVS verifies that PUT transitions to attaching Rp (Unattached.Accessory) after min (tPDDebounce + dcSRC.DRP x tDRP) and before max (tPDDebounce + dcSRC.DRP x tDRP). [TD.4.4.4.V.1]
 8. If PUT attaches Rp before tDRPTry + tPDDebounce expires:
 - a. CVS remains in Try.SNK
 - b. CVS verifies:
 - i. If VIF field Type_C_Supports_VCONN_Powered_Accessory is YES, PUT attaches Rd (transitions to Unattached.SNK) after min tCCDebounce and before max tCCDebounce + tAMETimeout. [TD.4.4.4.V.2]
 - ii. Else (in this case only VIF field Type_C_Supports_Audio_Accessory is YES), PUT attaches Rd (transitions to Unattached.SNK) after min dcSRC.DRP x tDRP and before max dcSRC.DRP x tDRP [TD.4.4.4.V.6]
 - c. When PUT attaches Rd, CVS transitions to TryWait.SRC after tPDDebounce.
 - d. Skip to step 10.
 9. CVS transitions to TryWait.SRC after max tDRPTry + max tPDDebounce expires.
 10. CVS verifies PUT transitions to Unattached.SNK after tPDDebounce [TD.4.4.4.V.3]
 11. CVS transitions to Attached.SRC after max tCCDebounce.
 12. CVS verifies that PUT transitions to Attached.SNK:
 - a. If PUT supports USB PD:
 - i. PUT and CVS establish an explicit contract [TD.4.4.4.V.4]
 - b. If PUT supports USB data:
 - i. PUT starts USB communication on its SS or D+/D- pairs. [TD.4.4.4.V.5]

TD 4.4.5 SNKAS Connect SNKAS Test

- A. Purpose:
1. Verify a SNKAS PUT interacts correctly with SNKAS
- B. Applicability
1. This test is required when VIF field Type_C_State_Machine is SNK and Type_C_Supports_Audio_Accessory or Type_C_Supports_VCONN_Powered_Accessory is YES.
- C. Asserts:
1. See TD 4.9
 2. 4.5.2.2.13.2#3
- D. Procedure:
1. CVS toggles between Unattached.SNK (and AttachWait.SNK) and Unattached.Accessory while performing steps 2 and 3.
 2. CVS waits 500ms.

3. CVS verifies that PUT also toggles between Unattached.SNK (and AttachWait.SNK) and Unattached.Accessory. [TD.4.4.5.V.1]
4. If PUT is not a PUT_R, the test is over.
5. CVS applies Ra on one CC for the remainder of the test.
6. If Type_C_Supports_Vconn_Powered_Accessory is NO:
 - a. CVS verifies that PUT continues to toggle between Unattached.SNK (and AttachWait.SNK) and Unattached.Accessory. [TD.4.4.5.V.2]
 - b. The test is over.
7. CVS transitions to Unattached.Accessory and starts timer max dcSRC.DRP x max tDRP (70ms).
8. CVS monitors CCs for Rd and verifies that Rd is connected before the timer expires.
9. CVS transitions to AttachWait.Accessory for tCCDebounce.
10. CVS transitions to PoweredAccessory and sources Vconn
11. If PUT VIF field Type_C_Is_Vconn_Powered_Accessory is YES
 - a. CVS verifies that PD signaling has commenced [TD.4.4.5.V.3]
 - b. The test is over.
12. CVS transitions to Try.SNK.
13. CVS verifies that:
 - a. PUT transitions to attaching Rp (Unattached.Accessory) after min (tPDDebounce + dcSRC.DRP x tDRP) and before max (tPDDebounce + dcSRC.DRP x tDRP). [TD.4.4.5.V.4]
 - b. PUT attaches Rd (transitions to Try.SNK) after min tCCDebounce and before max tCCDebounce + tAMETimeout. [TD.4.4.5.V.5]
14. When PUT attaches Rd, CVS waits tDRPTryWait min and then transitions to Unsupported.Accessory.
15. CVS verifies that CVS and PUT remain in Unsupported.Accessory and Try.SNK for tAMETimeout * 2. [TD.4.4.5.V.6]

TD 4.4.6 SNKAS Connect Audio Accessory

- A. Purpose:
 1. Verify a SNKAS PUT transitions to AudioAccessory Mode correctly with Audio Accessory
- B. Applicability
 1. This test is required when VIF field Type_C_State_Machine is SNK and Type_C_Supports_Audio_Accessory or Type_C_Supports_VCONN_Powered_Accessory is YES.
- C. Asserts
 1. 4.5.2.2.3.2#3
 2. 4.5.2.2.13.1#1-3
 3. 4.5.2.2.13.2#1
 4. 4.5.2.2.14.1#1-3
 5. 4.5.2.2.14.2#1
 6. 4.5.2.2.15.1#1-4
 7. 4.5.2.2.15.2#1
- D. Procedure:
 1. CVS presents an Audio Accessory (Both CC pins terminated with Ra).
 2. CVS verifies PUT transitions to Unattached.Accessory within dcSRC.DRP x tDRP [TD.4.4.6.V.1]
 3. If the VIF field Type_C_Supports_Audio_Accessory is YES:
 - a. CVS verifies PUT transition to AudioAccessory after tCCDebounce

- i. The PUT shall reconfigure its pins as defined in Appendix A [TD.4.4.6.V.2]
 - ii. The PUT does not drive VBUS or VCONN [TD.4.4.6.V.3]
 - iii. If the PUT sinks current over VBUS, it shall not be more than 500mA [TD.4.4.6.V.4]
 - iv. The PUT applies Rp on at least one CC [TD.4.4.6.V.5]
- 4. If the VIF field Type_C_Supports_Audio_Accessory is NO:
 - a. Wait tAMETimeout.
 - b. CVS verifies no Attached state is reached. [TD.4.4.6.V.6]
- 5. CVS transitions to Disabled
- 6. CVS verifies PUT transitions to Unattached.SNK within tCCDebounce.
 - a. The PUT terminates its CC(s) with Rd [TD.4.4.6.V.7]

TD 4.4.7 SNKAS Connect Debug Accessory

- A. Purpose:
 - 1. Verify a SNKAS PUT transitions to DebugAccessory Mode and does not source Vbus
- B. Applicability
 - 1. This test is required when VIF field Type_C_State_Machine is SNK and Type_C_Supports_Audio_Accessory or Type_C_Supports_VCONN_Powered_Accessory is YES.
- C. Asserts
 - 1. 4.5.2.2.14.1#2
- D. Procedure:
 - 1. CVS present a DTS (Debug and Test System) SNK by terminating CC pins with Rd
 - 2. CVS verifies PUT transitions to Unattached.Accessory within dcSRC.DRP x tDRP [TD.4.4.7.V.1]
 - 3. CVS verifies PUT does not source Vbus after tCCDebounce. [TD.4.4.7.V.2]

TD 4.4.8 SNKAS Connect PoweredAccessory

- A. Purpose:
 - 1. Verify a SNKAS PUT transitions to PoweredAccessory Mode correctly with a VCONN powered Accessory
- B. Applicability
 - 1. This test is required when VIF field Type_C_State_Machine is SNK and Type_C_Supports_VCONN_Powered_Accessory is YES.
- C. Asserts
 - 1. 4.5.2.2.13.1#1-3
 - 2. 4.5.2.2.13.2#2
 - 3. 4.5.2.2.14.1#1-3
 - 4. 4.5.2.2.14.2#3-4
 - 5. 4.5.2.2.19.1#2-6
 - 6. 4.5.2.2.19.2#1-4
 - 7. 4.5.2.2.20.1#1-3
 - 8. 4.5.2.2.20.2#1
- D. Procedure:
 - 1. CVS presents a VCONN powered Accessory (one CC pin terminated with Ra and one with Rd, D+/D- and SS terminations present)

2. CVS verifies the PUT transitions to Unattached.Accessory within dcSRC.DRP x tDRP [TD.4.4.8.V.1]
3. Wait 10ms.
4. CVS removes the Rd termination.
5. CVS verifies the PUT transitions to Unattached.SNK within tCCDebounce.
 - a. PUT has not sourced Vconn since start of test [TD.4.4.8.V.2]
 - b. PUT presents Rd terminations [TD.4.4.8.V.3]
6. CVS presents 1 CC pin in the vRa range and one in Rd like a VCONN powered Accessory.
7. CVS verifies the PUT transitions to Unattached.Accessory within dcSRC.DRP x tDRP [TD.4.4.8.V.4]
8. CVS verifies the PUT transitions to PoweredAccessory after tCCDebounce
 - a. PUT provides VCONN within tVCONNON-PA [TD.4.4.8.V.5]
 - b. PUT advertises vRd-1.5 or vRd-3.0 on Rp [TD.4.4.8.V.6]
 - c. PUT does not drive VBUS [TD.4.4.8.V.7]
 - d. PUT does not drive USB Host 3.1 or 2.0 traffic. [TD.4.4.8.V.8]
9. CVS verifies PUT transitions to Unsupported.Accessory within tAMETimeout + tDRPTryWait
 - a. PUT ceases to supply Vconn within tVconnOFF [TD.4.4.8.V.9]
 - b. PUT presents Rp terminations advertising Default USB current [TD.4.4.8.V.10]
10. CVS prompts the test operator whether a user notification has been provided by the product.
11. CVS verifies the test operator responded YES to the prompt. [TD.4.4.8.V.11]
12. CVS transitions to Disabled.
13. CVS verifies the PUT transitions to Unattached.SNK within tSRCDisconnect
 - a. PUT ceases to source Vconn within tVconnOFF [TD.4.4.8.V.12]
 - b. PUT presents Rd on its CCs [TD.4.4.8.V.13]
14. CVS presents a Vconn powered Accessory.
15. CVS verifies the PUT transitions to PoweredAccessory after tCCDebounce and within tCCDebounce + dcSRC.DRP x tDRP:
 - a. PUT provides Vconn within tVconnON-PA [TD.4.4.8.V.14]
 - b. PUT initiates a PD Explicit Contract [TD.4.4.8.V.15]
 - c. PUT initiates Alternate Mode discovery with Structured VDMs [TD.4.4.8.V.16]
16. CVS loads 1W on Vconn
17. CVS responds to Discover SVIDs with 1 bogus SVID
18. CVS waits max tAMETimeout (1.5s).
19. CVS verifies the PUT transitions to Unsupported.Accessory.
 - a. The PUT ceases to supply Vconn within tVconnOFF [TD.4.4.8.V.17]
 - b. The PUT does not drive VBUS [TD.4.4.8.V.18]
 - c. The PUT applies Rp on one CC pin, advertising default USB current [TD.4.4.8.V.19]
20. CVS prompts the test operator whether a user notification has been provided by the product.
21. CVS verifies the test operator responded YES to the prompt. [TD.4.4.8.V.20]
22. CVS transitions to Disabled.
23. CVS verifies the PUT transitions to Unattached.SNK within tSRCDisconnect. [TD.4.4.8.V.21]

These tests are for USB Type-C Connectors that implement the USB Type-C DRP Connection State Diagram in Figure 4-16. These tests are not applicable to DRPs that implement a Try.SNK State.

TD 4.5.1 DRP Connect Sink Test

- A. Purpose:
 1. Verify a DRP transitions through Unattached states to Attached.SRC
 2. Verify a DRP transitions to Unattached.SNK when the link partner is removed
- B. Applicability:
 1. This test is applicable when Type_C_State_Machine is DRP and Type_C_Implements_Try_SNK is NO and Type_C_Implements_Try_SRC is NO
- C. Asserts:
 1. 4.5.2.2.3.2#2
 2. 4.5.2.2.6.2#4
 3. 4.5.2.2.7.1#1-3
 4. 4.5.2.2.7.2#1,5
 5. 4.5.2.2.8.1#2,3-7
 6. 4.5.2.2.8.2#2-5
 7. 4.5.2.2.10.2#2
 8. 4.8.3#1
 9. 4.8.4#1
- D. Conditions:
 1. CVS emulates a SNK receptacle connector [TD.4.5.1.C.4]
 2. CVS emulates USB PD 2.0 5A Active Cable [TD.4.5.1.C.1]
 3. CVS emulates USB PD 3.0 5A Active Cable [TD.4.5.1.C.2]
 4. CVS emulates USB4 re-driver cable (ID Header Product Type = Passive, Cable VDO indicate Vconn required, TBT3 SVID / Mode supported and mode indicates Active Cable) [TD.4.5.1.C.3]
- E. Procedure:
 1. If VIF field Captive_Cable is set to YES, CVS emulates a receptacle as per condition 1 in Section D above, otherwise CVS emulates an Active cable as per condition 2
 2. If VIF field Type_C_Sources_Vconn is NO, CVS verifies that the PUT does not source Vconn for the remainder of the test. [TD.4.5.1.V.1]
 3. CVS transitions to Unattached.SNK
 4. CVS waits 5ms
 5. For a PUT_R:
 - a. CVS terminates one CC pin with Ra for the duration of the test.
 - b. CVS verifies PUT has transitioned to Unattached.SRC
 - i. PUT applies Rp simultaneously on both CC pins [TD.4.5.1.V.2]
 - c. CVS waits 80ms
 - d. CVS verifies PUT has applied Rp since step 2.b [TD.4.5.1.V.3]
 - e. CVS transitions to Disabled except for one CC maintaining Ra
 - f. CVS verifies PUT transitions to Unattached.SNK [TD.4.5.1.V.4]
 - g. Wait 750ms.
 - h. CVS transitions to Unattached.SNK
 6. CVS verifies:
 - a. PUT attaches Rp within max dcSRC.DRP x max tDRP [TD.4.5.1.V.5]
 - b. After tCCDebounce, PUT supplies VBUS within tVBUSON [TD.4.5.1.V.6]
 - c. PUT sources current at the level it advertises with Type-C Current [TD.4.5.1.V.7]
 7. Vconn_tested = false
 8. If PUT supports USB PD:
 - a. CVS verifies that:

- i. PUT stabilizes VBUS before initiating USB PD communications [TD.4.5.1.V.8]
 - ii. CVS and PUT negotiate a contract. [TD.4.5.1.V.9]
 - b. If PUT source capabilities include a Max Current > 3 A:
 - i. CVS verifies that for a PUT_R, it supplies Vconn within tVconnON [TD.4.5.1.V.10]
 - ii. Vconn_tested = true
- 9. If PUT supports USB 3.1 DFP:
 - a. CVS verifies that:
 - i. PUT attaches eSS terminations before Vbus on or within 80ms of Vbus on [TD.4.5.1.V.11]
 - ii. For a PUT_R and not Vconn_tested:
 - 01 It supplies VCONN within tVCONN [TD.4.5.1.V.12]
 - 02 Vconn_tested = true
 - iii. PUT transmits LFPS within 121ms of attaching eSS terminations OR transmits Warm Reset within 2s of attaching eSS terminations [TD.4.5.1.V.13]
 - iv. After eSS terminations are applied, and prior to PD Enter Mode negotiation if applicable, the SBU pins on the PUT are within zSBUTermination [TD.4.5.1.V.14]
 - b. CVS load 1W on Vconn
 - c. CVS waits 1s
- 10. If the PUT is a PUT_V and not Vconn_tested:
 - a. CVS verifies that for a PUT_R, it supplies Vconn within tVconnON [TD.4.5.1.V.19]
- 11. CVS transitions to Disabled
- 12. CVS verifies that PUT transitions to Unattached.SNK within tSRCDisconnect.
 - a. If PUT supports USB 3.1 DFP, Vconn remained on until after step 10 [TD.4.5.1.V.15]
 - b. PUT_V removes Vconn within tVconnOFF. [TD.4.5.1.V.16]
 - c. PUT removes VBUS within tVBUSOFF [TD.4.5.1.V.17]
 - d. PUT presents Rd terminations on its through CC pin [TD.4.5.1.V.18]
 - i. For a PUT_R, verify both CC pins terminated to Rd
- 13. If VIF field Captive_Cable is NO, the CVS continues the test with step 2, using the next Condition from section D above

TD 4.5.2 DRP Connect SNKAS Test

- A. Purpose:
 - 1. Verify a DRP transitions to Attached.SRC when connected to a SNKAS
- B. Applicability:
 - 1. This test is required for VIF field Type_C_State_Machine set to DRP and Type_C_Implements_Try_SNK is NO and Type_C_Implements_Try_SRC is NO.
- C. Asserts
 - 1. See TD 4.14
- D. Procedure:
 - 1. CVS transitions to Unattached.Accessory
 - 2. CVS waits 5ms
 - 3. CVS verifies that PUT attaches Rd within max dcSRC.DRP x max tDRP [TD.4.5.2.V.1]
 - 4. If PUT is a PUT_C and Ra is attached to its Vconn pin:
 - a. Complete steps 13 – 16.

- b. Skip to step 7
5. CVS transitions to Unattached.SNK after min dcSRC.DRP x min tDRP.
6. CVS verifies that PUT attaches Rp within max dcSRC.DRP x max tDRP [TD.4.5.2.V.2]
7. CVS verifies that PUT transitions to Attached.SRC after tCCDebounce:
 - a. PUT supplies VBUS within tVBUSON [TD.4.5.2.V.3]
 - b. If PUT supports USB PD:
 - i. VBUS reaches vSafe5V before initiating USB PD communications [TD.4.5.2.V.4]
8. CVS transitions to Disabled
9. CVS verifies that PUT transitions to Unattached.SNK within tSRCDisconnect.
 - a. PUT removes VBUS within tVBUSOFF [TD.4.5.2.V.5]
 - b. PUT presents Rd terminations on its through CC pin [TD.4.5.2.V.6]
 - i. For a PUT_R, verify both CC pins terminated to Rd
10. For a PUT_C the test is over.
11. CVS terminates one CC pin with Ra to look like an Emarked cable for the duration of the test.
12. Repeat steps 1 –3.
13. CVS transitions to PoweredAccessory after max tCCDebounce
14. If PUT has VIF field Type_C_Is_Vconn_Powered_Accessory set to YES then the test is over.
15. CVS transitions to Try.SNK and starts tDRPtry
16. CVS verifies PUT attaches Rp within tPDDebounce min and tPDDebounce max + tDRPTransition [TD.4.5.2.V.7]
17. Repeat steps 7-9.

TD 4.5.3 DRP Connect Source Test

- A. Purpose:
 1. Verify a DRP transitions through Unattached states to Attached.SNK
- B. Applicability
 1. This test is required when VIF field Type_C_State_Machine is DRP and and Type_C_Implements_Try_SRC is NO and Type_C_Implements_Try_SNK is NO.
- C. Asserts:
 1. 4.5.2.2.3.2#1-2
 2. 4.5.2.2.4.2#2
 3. 4.5.2.2.6.2#4
 4. 4.5.2.2.9.1#1-3
 5. 4.5.2.2.9.2#1-2
 6. 4.5.2.2.10.1#1-2
 7. 4.5.2.2.10.2#2
 8. 4.8.3#1
 9. 4.8.4#1
- D. Procedure:
 1. CVS transitions to Unattached.SRC
 2. CVS waits 5ms
 3. For a PUT_R, CVS terminates one CC pin with Ra for the duration of the test, except when CVS is in Disabled.
 4. CVS verifies:
 - a. PUT attaches Rd within max dcSRC.DRP x max tDRP [TD.4.5.3.V.1]
 - i. For a PUT_R, both CCs are terminated with Rd.
 5. CVS waits max tDRP
 6. CVS verifies PUT has applied Rd continuously since step 4 [TD.4.5.3.V.2]

7. CVS transitions to Disabled for 100ms
8. CVS verifies PUT transitioned to Unattached.SRC within step 7 [TD.4.5.3.V.3]
9. Wait 750ms.
10. CVS transitions to Unattached.SRC
11. Wait 5ms
12. CVS verifies:
 - a. PUT attaches Rd within max dcSRC.DRP x max tDRP [TD.4.5.3.V.4]
 - i. For a PUT_R, both CCs are terminated with Rd.
13. CVS transitions to Attached.SRC after max tCCDebounce.
14. CVS verifies PUT transitions to Attached.SNK:
 - a. PUT sinks current according to CVS advertisement [TD.4.5.3.V.5]
 - b. If PUT supports USB 3.1 UFP:
 - i. PUT starts data communications on its SuperSpeed pairs. [TD.4.5.3.V.6]
 - ii. After eSS terminations are applied, and prior to PD Enter Mode negotiation if applicable, the SBU pins on the PUT are within zSBUTermination [TD.4.5.3.V.7]
 - c. Else if PUT supports USB 2.0 UFP:
 - i. PUT starts data communications on its D+/D- pair [TD.4.5.3.V.8]
 - d. For a PUT_R, VCONN is not supplied [TD.4.5.3.V.9]
15. CVS transitions to Disabled
16. CVS verifies that PUT transitions to Unattached.SNK before tVBUSOFF expires
 - a. PUT ceases data communication [TD.4.5.3.V.10]
 - b. PUT stops sinking current over Vbus [TD.4.5.3.V.11]

TD 4.5.4 **DRP Connect DRP Test**

- A. Purpose:
 1. Verify a DRP transitions to an attached state
 2. Verify a DRP can support varying times of tDRP and dcSRC.DRP
- B. Applicability
 1. This test is required when VIF field Type_C_State_Machine is DRP and Type_C_Implements_Try_SRC is NO and Type_C_Implements_Try_SNK is NO.
- C. Asserts
 1. 4.5.2.2.7.2#1
 2. 4.5.2.2.8.1#7
 3. 4.5.2.2.9.1#1-3
 4. 4.5.2.2.9.2#2
 5. 4.5.2.2.10.1#1-2
 6. 4.5.2.2.10.2#1
 7. 4.8.3#1
- D. Timing Conditions:
 1. tDRP = 50ms, dcSRC.DRP = 30% [TD.4.5.4.C.1]
 2. tDRP = 75ms, dcSRC.DRP = 30% [TD.4.5.4.C.2]
 3. tDRP = 100ms, dcSRP.DRP = 30% [TD.4.5.4.C.3]
 4. tDRP = 50ms, dcSRC.DRP = 50% [TD.4.5.4.C.4]
 5. tDRP = 75ms, dcSRC.DRP = 50% [TD.4.5.4.C.5]
 6. tDRP = 100ms, dcSRC.DRP = 50% [TD.4.5.4.C.6]
 7. tDRP = 50ms, dcSRC.DRP = 70% [TD.4.5.4.C.7]
 8. tDRP = 75ms, dcSRC.DRP = 70% [TD.4.5.4.C.8]
 9. tDRP = 100ms, dcSRC.DRP = 70% [TD.4.5.4.C.9]
- E. Procedure:
 1. CVS uses Condition 1 above for tDRP and dcSRC.DRP

2. CVS transitions to Unattached.SRC for (dcSRC.DRP x tDRP).
 - a. CVS monitors CCs for Rd and transitions to AttachedWait.SRC if it is detected
 - b. If Rd is present for tCCDebounce:
 - i. CVS transitions to Attached.SRC.
 - ii. Skip to step 9.
3. CVS transitions to Unattached.SNK for tDRP – (dcSRC.DRP x tDRP).
 - a. CVS monitors CCs for Rp and transitions to AttachedWait.SNK if it is detected.
 - b. If Rp is present for tCCDebounce continue to step 4.
 - c. If the PUT has reached this step less than 5 times since step 1, transition to step 2.
4. CVS verifies PUT transitions to Attached.SRC:
 - a. PUT advertises VBUS capability over Rp [TD.4.5.4.V.1]
 - b. PUT sources VBUS within tCCDebounce + tVBUSOn [TD.4.5.4.V.2]
 - c. If PUT supports USB PD:
 - i. PUT stabilizes VBUS before initiating USB PD communications [TD.4.5.4.V.3]
5. CVS transitions to Disabled
6. CVS verifies that PUT transitions to Unattached.SNK within tSRCDDisconnect.
 - a. Vbus reaches vSave0V before tVBUSOFF expires [TD.4.5.4.V.5]
 - b. PUT ceases PD communications [TD.4.5.4.V.6]
 - c. PUT terminates CC with Rd [TD.4.5.4.V.7]
 - i. If PUT is a PUT_R, it terminates both CCs with Rd
7. CVS transitions to Unattached.SRC
 - a. For a PUT_R, one CC is terminated with Ra
8. CVS transitions to Attached.SRC
9. CVS verifies PUT transitions to Attached.SNK:
 - a. PUT sinks current according to CVS advertisement [TD.4.5.4.V.8]
 - b. If PUT supports PD, CVS and PUT establish a PD contract. [TD.4.5.4.V.9]
 - c. If PUT supports USB 3.1 UFP:
 - i. PUT starts data communications on its SuperSpeed pairs. [TD.4.5.4.V.10]
 - d. Else if PUT supports USB 2.0 UFP:
 - i. PUT starts data communications on its D+/D- pair. [TD.4.5.4.V.11]
 - e. For a PUT_R, VCONN is not supplied [TD.4.5.4.V.12]
10. CVS transmits Discover ID PD messaging for 200ms
11. CVS verifies PUT:
 - a. If USB_PD_Support is YES:
 - i. Responds with valid GoodCRC messages. [TD.4.5.4.V.13]
 - ii. If Responds_To_Discov_SOP is YES:
 - 01 Transmits valid Responder ACK messages. [TD.4.5.4.V.14]
12. CVS programs Vbus source to meet 3.7V at the PUT connector.
13. CVS verifies PUT remains in Attached.SNK.
 - a. PUT maintains Rd on its CC [TD.4.5.4.V.15]
 - b. For a PUT that supports USB 3.2 or USB 2.0 UFP, the data signaling is maintained. [TD.4.5.4.V.16]
14. CVS removes Rps. CVS USB 2.0 and USB 3.1 signaling behaves as a DFP in Attached.SRC as long as PUT is in Attached.SNK.
15. CVS decreases Vbus voltage by 0.1V.
 - a. Wait 100ms
 - b. If PUT removes Rd or Vbus source voltage is below 800mV, continue to step 16
 - c. CVS verifies PUT maintained Attached.SNK
 - i. PUT maintains Rd on its CC [TD.4.5.4.V.17]

- ii. For a PUT that supports USB 3.2 or USB 2.0 UFP, the data signaling is maintained [TD.4.5.4.V.18]
 - iii. PUT does not source Vbus [TD.4.5.4.V.19]
 - d. Continue to step 15
 - 16. CVS applies Rd
 - 17. CVS verifies PUT transitions to AttachWait.SRC within tOnePortToggleConnect:
 - a. PUT applies and maintains Rp on its CC [TD.4.5.4.V.20]
 - i. For a PUT_R, Rp is applied on both CCs
 - b. PUT does not source Vbus [TD.4.5.4.V.21]
 - c. All data signaling ceases [TD.4.5.4.V.22]
 - 18. If Vbus is at or below 800 mV, continue to step 20
 - 19. CVS verifies PUT remains in AttachWait.SRC for 500ms [TD.4.5.4.V.23]
 - 20. CVS removes Vbus source
 - 21. CVS verifies that PUT sources Vbus after Vbus is in vSafe0V, and before tVbusON expires. [TD.4.5.4.V.24]
 - 22. CVS transitions to Disabled
 - 23. CVS continues to Step 1 with the next Condition listed above.

TD 4.5.5 DRP Connect Try.SRC DRP Test

- A. Purpose:
 - 1. Verify a DRP transitions to Attached.SNK according to spec
- B. Applicability:
 - 1. This test applies when VIF field Type_C_State_Machine is DRP and Type_C_Implements_Try_SRC is NO and Type_C_Implements_Try_SNK is NO
- C. Asserts:
 - 1. 4.5.2.2.3.2#2
 - 2. 4.5.2.2.5.1#2-3,5
 - 3. 4.5.2.2.5.2#1
 - 4. 4.5.2.2.6.1#1-3
 - 5. 4.5.2.2.6.2#1
 - 6. 4.5.2.2.7.1#1-3
 - 7. 4.5.2.2.7.2#6
 - 8. 4.5.2.2.11.1#1-2
 - 9. 4.5.2.2.11.2#2
- D. Procedure:
 - 1. CVS transitions to Unattached.SNK
 - 2. CVS waits 5ms
 - 3. CVS verifies:
 - a. PUT presents Rp within tDRP – dcSRC.DRP x tDRP [TD.4.5.5.V.1]
 - b. PUT transitions from Rd to Rp within tDRPTransition [TD.4.5.5.V.8]
 - c. PUT transitions to Attached.SRC after tCCDebounce:
 - i. PUT sources Vbus within tVbusON. [TD.4.5.5.V.9]
 - 4. CVS transitions to Try.SRC.
 - 5. CVS verifies that PUT transitions to Unattached.SNK within tSRCDisconnect. [TD.4.5.5.V.2]
 - 6. CVS transitions to Attached.SRC after min tPDDebounce.
 - 7. CVS verifies that PUT transitions to Attached.SNK:
 - a. PUT sinks current according to CVS advertisement. [TD.4.5.5.V.3]
 - b. If PUT supports PD:
 - i. PUT and CVS negotiate an explicit contract. [TD.4.5.5.V.4]
 - c. If VIF field PUT supports USB 3.1 UFP:

- i. PUT starts data communications on its SuperSpeed pairs. [TD.4.5.5.V.5]
 - d. Else if PUT supports USB 2.0 UFP:
 - i. PUT starts data communications on its D+/D- pair. [TD.4.5.5.V.6]
- 8. CVS transitions to Disabled
- 9. CVS verifies that PUT transitions to Unattached.SNK before tVBUSOFF expires:
 - a. PUT data communication has ceased. [TD.4.5.5.V.7]

TD 4.5.6 DRP Connect Try.SNK DRP Test

- A. Purpose:
 - 1. Verify a DRP transitions to Attached.SRC according to spec
- B. Applicability:
 - 1. This test applies when VIF field Type_C_State_Machine is DRP and Type_C_Implements_Try_SRC is NO and Type_C_Implements_Try_SNK is NO
- C. Asserts:
 - 1. TBD
- D. Procedure:
 - 1. CVS transitions to Unattached.SRC
 - 2. CVS waits 5ms
 - 3. CVS verifies PUT:
 - a. Presents Rd within max dcSRC.DRP x max tDRP [TD.4.5.6.V.1]
 - b. Transitions from Rp to Rd within tDRPTransition [TD.4.5.6.V.2]
 - c. Applies Rd for tCCDebounce [TD.4.5.6.V.3]
 - 4. CVS transitions to Try.SNK.
 - 5. CVS verifies PUT attaches Rp within tPDDebounce min and tPDDebounce max + tDRPTransition [TD.4.5.6.V.4]
 - 6. CVS verifies that PUT transitions to Attached.SRC after tCCDebounce:
 - a. PUT source Vbus with tVbusON. [TD.4.5.6.V.5]
 - b. If PUT supports PD:
 - i. PUT and CVS negotiate an explicit contract. [TD.4.5.6.V.6]
 - c. If PUT supports USB 3.1 DFP:
 - i. PUT starts data communications on its SuperSpeed pairs. [TD.4.5.6.V.7]
 - d. Else if PUT supports USB 2.0 DFP:
 - i. PUT starts data communications on its D+/D- pair. [TD.4.5.6.V.8]
 - 7. CVS transitions to Disabled
 - 8. CVS verifies that PUT transitions to Unattached.SNK within tSRCDisconnect:
 - a. PUT stops sourcing Vbus within tVbusOFF [TD.4.5.6.V.9]
 - b. PUT data communication has ceased. [TD.4.5.6.V.10]

Try.SRC DRP Tests

TD 4.6.1 Try.SRC DRP Connect Source Test

- A. Purpose:
 - 1. Verify a Try.SNK DRP transitions to Attached.SNK according to spec
 - 2. Verify that removing VBUS transitions the PUT to Unattached.SNK
- B. Applicability:
 - 1. This test applies when VIF field Type_C_State_Machine is DRP and Type_C_Implements_Try_SRC is YES
- C. Asserts:
 - 1. TBD
- D. Procedure:
 - 1. CVS transitions to Unattached.SRC
 - 2. CVS waits 5ms
 - 3. For a PUT_R, CVS terminates one CC pin with Ra in any state other than Disabled for the remainder of the test.
 - 4. CVS verifies PUT presents Rd within max dcSRC.DRP x max tDRP [TD.4.6.1.V.1]
 - 5. CVS transitions to Attached.SRC after tCCDebounce:
 - 6. CVS verifies that PUT transitions to Try.SRC after Vbus is present.
 - a. PUT removes Rd and applies Rp. [TD.4.6.1.V.2]
 - 7. CVS transitions to Unattached.SRC at tSRCDisconnect – 1ms, but Vbus does not reach vSafe0V until the max tVbusOFF
 - 8. CVS verifies that PUT transitions to TryWait.SNK after tTryTimeout.
 - a. PUT removes Rp and applies Rd. [TD.4.6.1.V.3]
 - 9. CVS transitions to Attached.SRC after max tCCDebounce.
 - 10. CVS verifies that PUT transitions to Attached.SNK when Vbus reaches vSafe5V:
 - a. PUT sinks current according to CVS advertisement. [TD.4.6.1.V.4]
 - b. If PUT supports PD:
 - i. PUT and CVS negotiate an explicit contract. [TD.4.6.1.V.5]
 - c. If PUT supports USB 3.1 UFP:
 - i. PUT starts data communications on its SuperSpeed pairs. [TD.4.6.1.V.6]
 - ii. After eSS terminations are applied, and prior to PD Enter Mode negotiation if applicable, the SBU pins on the PUT are within zSBUTermination [TD.4.6.1.V.7]
 - d. Else if PUT supports USB 2.0 UFP:
 - i. PUT starts data communications on its D+/D- pair [TD.4.6.1.V.8]
 - e. For a PUT_R, VCONN is not supplied [TD.4.6.1.V.9]
 - 11. CVS transmits Discover ID PD messaging for 200ms.
 - 12. CVS verifies that PUT:
 - a. If USB_PD_Support is YES:
 - i. Responds with valid GoodCRC messages. [TD.4.6.1.V.10]
 - ii. If Responds_To_Discov_SOP is YES:
 - 01 Transmits valid Responder ACK messages. [TD.4.6.1.V.11]
 - b. Remains in Attached.SNK during and for 500ms after step 6. [TD.4.6.1.V.12]
 - 13. CVS transitions to Disabled
 - 14. CVS verifies that PUT transitions to Unattached.SNK before tVBUSOFF expires:
 - a. PUT data communication has ceased. [TD.4.6.1.V.13]

TD 4.6.2 Try.SRC DRP Connect DRP Test

- A. Purpose:
1. Verify a DRP that transitions to Try.SRC transitions through to an Attached state
 2. Verify a DRP can support varying times of tDRP and dcSRC.DRP
- B. Applicability
1. This test is required when VIF field Type_C_State_Machine is DRP and Type_C_Implements_Try_SRC is YES.
- C. Asserts
1. 4.5.2.2.3.1#1-2
 2. 4.5.2.2.3.2#1
 3. 4.5.2.2.4.1#1-2
 4. 4.5.2.2.4.2#3
 5. 4.5.2.2.5.1#2-3,5-6
 6. 4.5.2.2.5.2#1
 7. 4.5.2.2.6.1#1-3
 8. 4.5.2.2.6.2#1
 9. 4.5.2.2.7.1#1-3
 10. 4.5.2.2.7.2#6
 11. 4.5.2.2.11.1#1-2
 12. 4.5.2.2.11.2#2
 13. TBD
- D. Timing Conditions:
1. tDRP = 50ms, dcSRC.DRP = 30% [TD.4.6.2.C.1]
 2. tDRP = 75ms, dcSRC.DRP = 30% [TD.4.6.2.C.2]
 3. tDRP = 100ms, dcSRP.DRP = 30% [TD.4.6.2.C.3]
 4. tDRP = 50ms, dcSRC.DRP = 50% [TD.4.6.2.C.4]
 5. tDRP = 75ms, dcSRC.DRP = 50% [TD.4.6.2.C.5]
 6. tDRP = 100ms, dcSRC.DRP = 50% [TD.4.6.2.C.6]
 7. tDRP = 50ms, dcSRC.DRP = 70% [TD.4.6.2.C.7]
 8. tDRP = 75ms, dcSRC.DRP = 70% [TD.4.6.2.C.8]
 9. tDRP = 100ms, dcSRC.DRP = 70% [TD.4.6.2.C.9]
- E. Procedure:
1. CVS uses Condition 1 above for tDRP and dcSRC.DRP
 2. For a PUT_R, one CC is terminated with Ra for the test.
 3. CVS transitions to Unattached.SRC for (dcSRC.DRP x tDRP).
 - a. CVS monitors for the presence of Rd and transitions to AttachedWait.SRC if it is detected.
 - b. If Rd is present for min tCCDebounce:
 - i. CVS keeps tCCDebounce timer running
 - ii. CVS transitions to Attached.SRC
 - iii. If vSafe5V is present before tCCDebounce max expires, CVS verifies that PUT attaches Rps within tSRCDisconnect of tCCDebounce expiration. [TD.4.6.2.V.1]
 - iv. Else, CVS verifies PUT attaches Rps within tSRCDisconnect of vSafe5V detection. [TD.4.6.2.V.2]
 - v. CVS transitions through Unattached.SNK to AttachWait.SNK for max tCCDebounce
 - vi. Skip to step 5
 4. CVS transitions to Unattached.SNK for tDRP – (dcSRC.DRP x tDRP).
 - a. CVS monitors for the presence of Rp and transitions to AttachedWait.SNK if it is detected.
 - b. If Rp is present for tCCDebounce:
 - i. CVS transitions to Attached.SNK.
 - ii. Continue to step 5.

- c. If the PUT has reached this step less than 5 times since step 1, transition to step 3.
 5. CVS verifies PUT transitions to Attached.SRC:
 - a. PUT sources Vbus within tVbusON. [TD.4.6.2.V.3]
 - b. If PUT supports USB PD:
 - i. PUT stabilizes VBUS before initiating USB PD communications [TD.4.6.2.V.4]
 - c. If PUT supports USB 3.1 DFP:
 - i. PUT starts data communications on its SuperSpeed pairs. [TD.4.6.2.V.6]
 - d. Else if PUT supports USB 2.0 DFP:
 - i. PUT starts data communications on its D+/D- pair. [TD.4.6.2.V.7]
 - e. For a PUT_V, VCONN is supplied [TD.4.6.2.V.8]
 6. CVS transitions to Disabled
 7. CVS verifies that PUT transitions to TryWait.SNK before tVBUSOFF expires:
 - a. PUT ceases all data communications [TD.4.6.2.V.9]
 8. CVS verifies that PUT transitions to Unattached.SRC after min (tPDDebounce + dcSRC.DRP x tDRP) and before max (tPDDebounce + dcSRC.DRP x tDRP). [TD.4.6.2.V.10]
 9. Wait 750ms.
 10. CVS continues to Step 1 with the next Condition listed above.

TD 4.6.3 Try.SRC DRP Connect Try.SRC DRP Test

- A. Purpose:
 1. Verify a Try.SRC DRP transitions to an Attached state according to spec
 2. Verify that a Try.SRC DRP will connect with another Try.SRC DRP
- B. Applicability:
 1. This test applies when VIF field Type_C_State_Machine is DRP and Type_C_Implements_Try_SRC is YES
- C. Asserts:
 1. TBD
- D. Procedure:
 1. CVS transitions to Unattached.SNK
 2. CVS waits 5ms
 3. CVS verifies:
 - a. PUT presents Rp within max dcSRC.DRP x max tDRP [TD.4.6.3.V.1]
 - b. PUT transitions from Rd to Rp within tDRPTransition [TD.4.6.3.V.2]
 4. CVS transitions to AttachWait.SNK
 5. CVS verifies PUT transitions to Attached.SRC after tCCDebounce:
 - a. PUT sources Vbus within tVbusON [TD.4.6.3.V.3]
 6. CVS transitions to Try.SRC.
 - a. CVS verifies PUT transitions to TryWait.SNK within 50 ms after CVS removes Rd. [TD.4.6.3.V.4]
 7. CVS transitions to Attached.SRC after max tCCTryDebounce.
 8. CVS verifies PUT transition to Attached.SNK:
 - a. If PUT supports PD:
 - i. PUT and CVS negotiate an explicit contract. [TD.4.6.3.V.5]
 - b. If PUT supports USB 3.1 UFP:
 - i. PUT starts data communications on its SuperSpeed pairs. [TD.4.6.3.V.6]
 - c. Else if PUT supports USB 2.0 UFP:

- i. PUT starts data communications on its D+/D- pair. [TD.4.6.3.V.7]
9. CVS programs Vbus source to meet 3.7V at the PUT connector.
10. CVS verifies PUT remains in Attached.SNK.
 - a. PUT maintains Rd on its CC [TD.4.6.3.V.8]
 - b. For a PUT that supports USB 3.2 or USB 2.0 UFP, the data signaling is maintained. [TD.4.6.3.V.9]
11. CVS removes Rps. CVS USB 2.0 and USB 3.1 signaling behaves as a DFP in Attached.SRC as long as PUT is in Attached.SNK.
12. CVS decreases Vbus voltage by 0.1V.
 - a. Wait 100ms
 - b. If PUT removes Rd or Vbus source voltage is below 800mV, continue to step 13
 - c. CVS verifies PUT maintained Attached.SNK
 - i. PUT maintains Rd on its CC [TD.4.6.3.V.10]
 - ii. For a PUT that supports USB 3.2 or USB 2.0 UFP, the data signaling is maintained [TD.4.6.3.V.11]
 - iii. PUT does not source Vbus [TD.4.6.3.V.12]
 - d. Continue to step 12
13. CVS applies Rd
14. CVS verifies PUT transitions to AttachWait.SRC within tOnePortToggleConnect:
 - a. PUT applies and maintains Rp on its CC [TD.4.6.3.V.13]
 - i. For a PUT_R, Rp is applied on both CCs
 - b. PUT does not source Vbus [TD.4.6.3.V.14]
 - c. All data signaling ceases [TD.4.6.3.V.15]
15. If Vbus is at or below 800 mV, continue to step 17
16. CVS verifies PUT stays in AttachWait.SRC for 500ms [TD.4.6.3.V.16]
17. CVS removes Vbus source
18. CVS verifies that PUT sources Vbus after Vbus is in vSafe0V, and before tVbusON expires. [TD.4.6.3.V.17]
19. CVS transitions to Disabled

TD 4.6.4 Try.SRC DRP Connect Try.SNK DRP Test

- A. Purpose:
 1. Verify a Try.SRC DRP transitions to Attached.SRC according to spec
- B. Applicability:
 1. This test applies when VIF field Type_C_State_Machine is DRP and Type_C_Implements_Try_SRC is YES
- C. Asserts:
 1. TBD
- D. Procedure:
 1. CVS transitions to Unattached.SRC
 2. CVS waits 5ms
 3. CVS verifies PUT:
 - a. Presents Rd within max dcSRC.DRP x max tDRP [TD.4.6.4.V.1]
 - b. Transitions from Rp to Rd within tDRPTransition [TD.4.6.4.V.2]
 4. CVS transitions to AttachWait.SRC
 5. CVS verifies PUT keeps Rd attached since step 3 for tCCDebounce [TD.4.6.4.V.3]
 6. CVS transitions to Try.SNK
 7. CVS verifies PUT attaches Rp after tPDDebounce [TD.4.6.4.V.4]
 8. CVS waits max tDRPTry.
 9. CVS verifies that PUT and CVS attach with PUT in Attached.SRC:

- a. PUT source Vbus with tVbusON. [TD.4.6.4.V.5]
- b. If PUT supports PD:
 - i. PUT and CVS negotiate an explicit contract. [TD.4.6.4.V.6]
- c. If PUT supports USB 3.1 DFP:
 - i. PUT starts data communications on its SuperSpeed pairs. [TD.4.6.4.V.7]
- d. Else if PUT supports USB 2.0 DFP:
 - i. PUT starts data communications on its D+/D- pair. [TD.4.6.4.V.8]
- 10. CVS transitions to Disabled
- 11. CVS verifies that PUT transitions to Unattached.SNK within tSRCDisconnect:
 - a. PUT stops sourcing Vbus within tVbusOFF [TD.4.6.4.V.9]
 - b. PUT data communication has ceased. [TD.4.6.4.V.10]

TD 4.6.5 Try.SRC DRP Connect Sink Test

- A. Purpose:
 - 1. Verify a Try.SRC DRP transitions to Attached.SRC according to spec
 - 2. Verify a PUT transitions to Unattached.SNK when Sink removed
- B. Applicability:
 - 1. This test applies when VIF field Type_C_State_Machine is DRP and Type_C_Implements_Try_SRC is YES
- C. Asserts:
 - 1. 4.4.2#1-3
 - 2. 4.5.2.2.6.1#1-3
 - 3. 4.5.2.2.6.2#1
 - 4. 4.5.2.2.7.1#1-3
 - 5. 4.5.2.2.7.2#1,5
 - 6. 4.5.2.2.8.1#2,4-10
 - 7. 4.5.2.2.8.2#1
 - 8. 4.6.2.1#3
 - 9. 4.6.2.4#1,2
- D. Conditions:
 - 1. CVS emulates a SNK receptacle connector [TD.4.6.5.C.4]
 - 2. CVS emulates USB PD 2.0 5A Active Cable [TD.4.6.5.C.1]
 - 3. CVS emulates USB PD 3.0 5A Active Cable [TD.4.6.5.C.2]
 - 4. CVS emulates USB4 re-driver cable (ID Header Product Type = Passive, Cable VDO indicate Vconn required, TBT3 SVID / Mode supported and mode indicates Active Cable) [TD.4.6.5.C.3]
- E. Procedure:
 - 1. If VIF field Captive_Cable is set to YES, CVS emulates a receptacle as per condition 1 in Section D above, otherwise CVS emulates an Active cable as per condition 2
 - 2. If VIF field Type_C_Sources_Vconn is NO, CVS verifies the PUT does not source Vconn for the remainder of the test [TD.4.6.5.V.1]
 - 3. CVS transitions to Unattached.SNK.
 - 4. CVS waits 5ms
 - 5. For a PUT_R:
 - a. CVS terminates one CC pin with Ra for the duration of the test.
 - b. CVS verifies PUT transitions to Unattached.SRC within tDRP
 - i. PUT applies Rp simultaneously on both CC pins [TD.4.6.5.V.2]
 - c. CVS waits 80ms
 - d. CVS transitions to Disabled except for one CC maintaining Ra
 - e. CVS verifies PUT transitions to Unattached.SNK [TD.4.6.5.V.3]

- f. Wait 750ms.
- g. CVS transitions to Unattached.SNK
- h. Wait 5ms
- 6. CVS verifies that:
 - a. CVS detects SNK.Rp on its Rd terminated CC pin within tDRP [TD.4.6.5.V.4]
 - b. PUT transitions to Attached.SRC by sourcing VBUS after tCCDebounce and before tCCDebounce + tVBUSON expires after CVS detects SNK.Rp [TD.4.6.5.V.5]
 - c. PUT sources current at the level advertised with Type-C Current. [TD.4.6.5.V.6]
- 7. Vconn_tested = false
- 8. If PUT supports USB PD:
 - a. CVS verifies that:
 - i. PUT stabilizes VBUS before initiating USB PD communications [TD.4.6.5.V.7]
 - ii. CVS and PUT negotiate a contract. [TD.4.6.5.V.8]
 - b. If PUT source capabilities include a Max Current > 3 A:
 - i. CVS verifies that for a PUT_R, it supplies Vconn within tVconnON [TD.4.6.5.V.9]
 - ii. Vconn_tested = true
- 9. If PUT supports USB 3.1 DFP:
 - a. CVS verifies that:
 - i. PUT attaches eSS terminations before Vbus on or within 80ms of Vbus on [TD.4.6.5.V.10]
 - ii. For a PUT_R and not Vconn_tested:
 - 01 It supplies VCONN within tVCONN [TD.4.6.5.V.11]
 - 02 Vconn_tested = true
 - iii. PUT transmits LFPS within 121ms of attaching eSS terminations OR transmits Warm Reset within 2s of attaching eSS terminations [TD.4.6.5.V.12]
 - iv. After eSS terminations are applied, and prior to PD Enter Mode negotiation if applicable, the SBU pins on the PUT are within zSBUTermination [TD.4.6.5.V.13]
 - b. CVS load 1W on Vconn
 - c. CVS waits 1s
- 10. If the PUT is a PUT_V and not Vconn_tested:
 - a. CVS verifies that for a PUT_R, it supplies Vconn within tVconnON [TD.4.6.5.V.14]
- 11. CVS transitions to Disabled
- 12. CVS verifies that PUT transitions to TryWait.SNK within tSRCDisconnect:
 - a. PUT removes Vbus within tVbusOFF [TD.4.6.5.V.15]
 - b. If PUT supports USB 3.1 DFP, it keeps sourcing Vconn until after step 10 [TD.4.6.5.V.16]
 - c. All clocked signaling has stopped [TD.4.6.5.V.17]
 - d. PUT attaches Rd on its CC [TD.4.6.5.V.18]
 - i. For a PUT_R, it attaches Rd on both CCs
- 13. If VIF field Captive_Cable is NO, the CVS continues the test with step 2, using the next Condition from section D above

TD 4.6.6 Try.SRC DRP Connect SNKAS Test

- A. Purpose:
 - 1. Verify a Try.SNK PUT transitions to Attached.SRC correctly with SNKAS
- B. Applicability
 - 1. This test is required when VIF field Type_C_State_Machine is DRP and Type_C_Implements_Try_SRC is YES
- C. Asserts:
 - 1. TBD
- D. Procedure:
 - 1. CVS transitions to Unattached.Accessory
 - 2. CVS Wait 5ms
 - 3. CVS monitors CCs for Rd and verifies that Rd is connected within max dcSRC.DRP x max tDRP. [TD.4.6.6.V.1]
 - 4. If PUT is a PUT_C with an Ra on its plug's Vconn pin:
 - a. Complete steps 14 – 16.
 - b. Skip to step 7.
 - 5. CVS transitions to Unattached.SNK after max dcSRC.DRP x max tDRP
 - 6. CVS verifies PUT applies Rp after tPDDebounce. [TD.4.6.6.V.2]
 - 7. CVS verifies PUT and CVS transition to Attached.SRC and Attached.SNK after tCCDebounce
 - a. PUT sources Vbus within tVbusOn [TD.4.6.6.V.3]
 - b. If PUT supports PD messaging:
 - i. PUT and CVS negotiate an explicit contract [TD.4.6.6.V.4]
 - c. If PUT supports USB 3.1 DFP
 - i. PUT starts USB communications on its SS pairs [TD.4.6.6.V.5]
 - d. If PUT supports USB 2.0 DFP
 - i. PUT starts USB communications on its D+/D- pair [TD.4.6.6.V.6]
 - 8. CVS transitions to Disabled for 750ms
 - 9. CVS verifies PUT transitions to TryWait.SNK before tVBUSOFF expires:
 - a. PUT data communication has ceased [TD.4.6.6.V.7]
 - 10. If the PUT is not a PUT_R the test is over.
 - 11. CVS waits min tPDDebounce
 - 12. CVS attaches Ra to one CC to appear as an Emarked Cabled for the remainder of the test
 - 13. Repeat steps 1-3.
 - 14. CVS transitions to PoweredAccessory after max tCCDebounce
 - 15. If PUT has VIF field Type_C_Is_Vconn_Powered_Accessory set to YES:
 - a. CVS verifies PUT responds with PD signaling. [TD.4.6.6.V.8]
 - b. CVS transitions to Disabled for 750ms.
 - c. CVS transitions to Unattached.SNK
 - 16. Else Type_C_Is_Vconn_Powered_Accessory is NO:
 - a. CVS transitions to Try.SNK after 1 second and starts tDRPtry
 - b. CVS verifies PUT transitions to Unattached.SRC after tPDDebounce [TD.4.6.6.V.9]
 - 17. Repeat steps 7-9.

Try.SNK DRP Tests

TD 4.7.1 Try.SNK DRP Connect Source Test

- A. Purpose:

1. Verify a Try.SNK DRP transitions to Attached.SNK according to spec
 2. Verify that removing VBUS transitions the PUT to Unattached.SRC
- B. Applicability:
1. This test applies when VIF field Type_C_State_Machine is DRP and Type_C_Implements_Try_SNK is YES
- C. Asserts:
1. 4.5.2.2.3.2#1
 2. 4.5.2.2.4.1#1-2
 3. 4.5.2.2.4.2#3
 4. 4.5.2.2.5.1#2-3,5-6
 5. 4.5.2.2.5.2#1
 6. 4.5.2.2.6.2#4
- D. Procedure:
1. CVS transitions to Unattached.SRC
 2. CVS waits 5ms
 3. For a PUT_R, CVS terminates one CC pin with Ra in any state other than Disabled for the remainder of the test.
 4. CVS verifies:
 - a. PUT presents Rd within max dcSRC.DRP x max tDRP [TD.4.7.1.V.1]
 - b. PUT transitions from Rp to Rd within tDRPTransition [TD.4.7.1.V.2]
 - c. PUT applies Rd for tCCDebounce [TD.4.7.1.V.3]
 5. CVS transitions to Attached.SRC
 6. CVS verifies that PUT transitions to Attached.SNK:
 - a. PUT sinks current according to CVS advertisement. [TD.4.7.1.V.4]
 - b. If PUT supports PD:
 - i. PUT and CVS negotiate an explicit contract. [TD.4.7.1.V.5]
 - c. If PUT supports USB 3.1:
 - i. PUT starts data communications on its SuperSpeed pairs. [TD.4.7.1.V.6]
 - ii. After eSS terminations are applied, and prior to PD Enter Mode negotiation if applicable, the SBU pins on the PUT are within zSBUTermination [TD.4.7.1.V.7]
 - d. Else if PUT supports USB 2.0:
 - i. PUT starts data communications on its D+/D- pair [TD.4.7.1.V.8]
 - e. For a PUT_R, VCONN is not supplied [TD.4.7.1.V.9]
 7. CVS transmits Discover ID PD messaging for 200ms.
 8. CVS verifies that PUT:
 - a. If USB_PD_Support is YES:
 - i. Responds with valid GoodCRC messages. [TD.4.7.1.V.10]
 - ii. If Responds_To_Discov_SOP is YES:
 - 01 Transmits valid Responder ACK messages. [TD.4.7.1.V.11]
 - b. Remains in Attached.SNK during and for 500ms after step 6. [TD.4.7.1.V.12]
 9. CVS transitions to Disabled
 10. CVS verifies that PUT transitions to Unattached.SNK before tVBUSOFF expires:
 - a. PUT data communication has ceased. [TD.4.7.1.V.13]

TD 4.7.2 Try. SNK DRP Connect DRP Test

- A. Purpose:
1. Verify a DRP that transitions to Try.SNK transitions through to an Attached state

2. Verify a DRP can support varying times of tDRP and dcSRC.DRP
- B. Applicability
1. This test is required when VIF field Type_C_State_Machine is DRP and Type_C_Implements_Try_SNK is YES.
- C. Asserts
1. 4.5.2.2.3.1#1-2
 2. 4.5.2.2.3.2#1
 3. 4.5.2.2.4.1#1-2
 4. 4.5.2.2.4.2#3
 5. 4.5.2.2.5.1#2-3,5-6
 6. 4.5.2.2.5.2#1
 7. 4.5.2.2.6.1#1-3
 8. 4.5.2.2.6.2#1
 9. 4.5.2.2.7.1#1-3
 10. 4.5.2.2.7.2#6
 11. 4.5.2.2.11.1#1-2
 12. 4.5.2.2.11.2#2
- D. Timing Conditions:
1. tDRP = 50ms, dcSRC.DRP = 30% [TD.4.7.2.C.1]
 2. tDRP = 75ms, dcSRC.DRP = 30% [TD.4.7.2.C.2]
 3. tDRP = 100ms, dcSRP.DRP = 30% [TD.4.7.2.C.3]
 4. tDRP = 50ms, dcSRC.DRP = 50% [TD.4.7.2.C.4]
 5. tDRP = 75ms, dcSRC.DRP = 50% [TD.4.7.2.C.5]
 6. tDRP = 100ms, dcSRC.DRP = 50% [TD.4.7.2.C.6]
 7. tDRP = 50ms, dcSRC.DRP = 70% [TD.4.7.2.C.7]
 8. tDRP = 75ms, dcSRC.DRP = 70% [TD.4.7.2.C.8]
 9. tDRP = 100ms, dcSRC.DRP = 70% [TD.4.7.2.C.9]
- E. Procedure:
1. CVS uses Condition 1 above for tDRP and dcSRC.DRP
 2. For a PUT_R, one CC is terminated with Ra for the test.
 3. CVS transitions to Unattached.SNK for tDRP – (dcSRC.DRP x tDRP).
 - a. CVS monitors CCs for Rp and transitions to AttachedWait.SNK if it is detected
 - b. If Rp is present for tDRP:
 - i. CVS verifies that PUT attaches Rds after tCCDebounce. [TD.4.7.2.V.1]
 - ii. CVS transitions through Unattached.SRC and AttachWait.SRC to Attached.SRC
 - iii. Skip to step 5
 4. CVS transitions to Unattached.SRC for (dcSRC.DRP x tDRP).
 - a. CVS monitors CCs for Rd and transitions to AttachedWait.SRC if it is detected.
 - b. If Rd is present for longer than tCCDebounce, CVS transitions to Attached.SRC. Continue to step 5.
 - c. If the PUT has reached this step less than 5 times since step 1, transition to step 3.
 5. CVS verifies PUT transitions to Attached.SNK:
 - a. If PUT supports USB PD:
 - i. PUT stabilizes VBUS before initiating USB PD communications [TD.4.7.2.V.2]
 - b. PUT sinks current according to CVS advertisement [TD.4.7.2.V.4]
 - c. If PUT supports USB 3.1:
 - i. PUT starts data communications on its SuperSpeed pairs. [TD.4.7.2.V.5]
 - d. Else if PUT supports USB 2.0:
 - i. PUT starts data communications on its D+/D- pair. [TD.4.7.2.V.6]

- e. For a PUT_R, VCONN is not supplied [TD.4.7.2.V.7]
6. CVS transmits Discover ID PD messaging for 200ms
7. CVS verifies PUT:
 - a. If USB_PD_Support is YES:
 - i. Responds with valid GoodCRC messages. [TD.4.7.2.V.8]
 - ii. If Responds_To_Discov_SOP is YES:
 - 01 Transmits valid Responder ACK messages. [TD.4.7.2.V.9]
 - b. Remains in Attached.SNK during and for 500ms after step 6. [TD.4.7.2.V.10]
8. CVS programs Vbus source to meet 3.7V at the PUT connector.
9. CVS verifies PUT remains in Attached.SNK.
 - a. PUT maintains Rd on its CC [TD.4.7.2.V.11]
 - b. For a PUT that supports USB 3.2 or USB 2.0 signaling, the data signaling is maintained. [TD.4.7.2.V.12]
10. CVS removes Rps. CVS USB 2.0 and USB 3.1 signaling behaves as though it is in Attached.SRC as long as PUT is in Attached.SNK.
11. CVS decreases Vbus voltage by 0.1V.
 - a. Wait 100ms
 - b. If PUT removes Rd or Vbus source voltage is below 800mV, continue to step 12
 - c. CVS verifies PUT maintained Attached.SNK
 - i. PUT maintains Rd on its CC [TD.4.7.2.V.13]
 - ii. For a PUT that supports USB 3.2 or USB 2.0 signaling, the data signaling is maintained [TD.4.7.2.V.14]
 - iii. PUT does not source Vbus [TD.4.7.2.V.15]
 - d. Continue to step 11
12. CVS applies Rd
13. CVS verifies PUT transitions to AttachWait.SRC within tOnePortToggleConnect:
 - a. PUT applies and maintains Rp on its CC [TD.4.7.2.V.16]
 - i. For a PUT_R, Rp is applied on both CCs
 - b. PUT does not source Vbus [TD.4.7.2.V.17]
 - c. All data signaling ceases [TD.4.7.2.V.18]
14. If Vbus is at or below 800 mV, continue to step 16
15. CVS verifies PUT remains in AttachWait.SRC for 500ms [TD.4.7.2.V.19]
16. CVS removes Vbus source
17. CVS verifies that PUT transitions to Try.SNK:
 - a. PUT applies Rd [TD.4.7.2.V.20]
18. CVS transitions to Disabled
19. CVS continues to Step 1 with the next Condition listed above.

TD 4.7.3 Try. SNK DRP Connect Try.SRC DRP Test

- E. Purpose:
 1. Verify a Try.SNK DRP transitions to Attached.SNK according to spec
- F. Applicability:
 1. This test applies when VIF field Type_C_State_Machine is DRP and Type_C_Implements_Try_SNK is YES
- G. Asserts:
 1. 4.5.2.2.3.2#2
 2. 4.5.2.2.5.1#2-3,5
 3. 4.5.2.2.5.2#1
 4. 4.5.2.2.6.1#1-3

5. 4.5.2.2.6.2#1
6. 4.5.2.2.7.1#1-3
7. 4.5.2.2.7.2#6
8. 4.5.2.2.11.1#1-2
9. 4.5.2.2.11.2#2

H. Procedure:

1. CVS transitions to Unattached.SNK
2. CVS waits 5ms
3. CVS verifies:
 - a. PUT presents Rp within tDRP – dcSRC.DRP x tDRP [TD.4.7.3.V.1]
 - b. PUT transitions from Rd to Rp within tDRPTransition [TD.4.7.3.V.2]
4. CVS transitions to AttachWait.SNK
5. CVS verifies PUT keeps Rp attached since step 3 for tCCDebounce [TD.4.7.3.V.3]
6. CVS verifies PUT transitions to Try.SNK within tCCDebounce max + tDRPTransition since step 2:
 - a. PUT presents Rd [TD.4.7.3.V.4]
7. CVS transitions to Unattached.SRC after tPDDebounce, and on to AttachWait.SRC for tCCDebounce
8. CVS transitions to Attached.SRC:
9. CVS verifies that PUT transitions to Attached.SNK:
 - a. PUT sinks current according to CVS advertisement. [TD.4.7.3.V.5]
 - b. If PUT supports PD:
 - i. PUT and CVS negotiate an explicit contract. [TD.4.7.3.V.6]
 - c. If VIF field PUT supports USB 3.1:
 - i. PUT starts data communications on its SuperSpeed pairs. [TD.4.7.3.V.7]
 - d. Else if PUT supports USB 2.0:
 - i. PUT starts data communications on its D+/D- pair. [TD.4.7.3.V.8]
10. CVS transitions to Disabled
11. CVS verifies that PUT transitions to Unattached.SNK before tVBUSOFF expires:
 - a. PUT data communication has ceased. [TD.4.7.3.V.9]

TD 4.7.4 Try.SNK DRP Connect Try.SNK DRP Test

A. Purpose:

1. Verify a Try.SNK DRP transitions to an Attached state according to spec
2. Verify that a Try.SNK DRP will connect with another Try.SNK DRP

B. Applicability:

1. This test applies when VIF field Type_C_State_Machine is DRP and Type_C_Implements_Try_SNK is YES

C. Asserts:

1. TBD

D. Procedure:

1. CVS transitions to Unattached.SNK
2. CVS waits 5ms
3. CVS verifies PUT presents Rp within max dcSRC.DRP x maxtDRP [TD.4.7.4.V.1]
4. CVS transitions to AttachWait.SNK
5. CVS verifies:
 - a. PUT keeps Rp attached since step 3 for tCCDebounce [TD.4.7.4.V.2]
 - b. PUT removes Rp and presents Rd [TD.4.7.4.V.3]

6. CVS transitions to Unattached.SRC after min tPDDebounce, and on to AttachWait.SRC for max tCCDebounce
7. CVS transitions to Try.SNK for tDRPTry
8. CVS verifies PUT presents Rp after tPDDebounce [TD.4.7.4.V.4]
9. CVS verifies PUT and CVS transition to Attached.SRC and Attached.SNK:
 - a. PUT sources Vbus within tVbusON [TD.4.7.4.V.5]
 - b. If PUT supports PD:
 - i. PUT and CVS negotiate an explicit contract. [TD.4.7.4.V.6]
 - c. If PUT supports USB 3.1:
 - i. PUT starts data communications on its SuperSpeed pairs. [TD.4.7.4.V.7]
 - d. Else if PUT supports USB 2.0:
 - i. PUT starts data communications on its D+/D- pair. [TD.4.7.4.V.8]
10. CVS transitions to Disabled
11. CVS verifies that PUT transitions to Unattached.SNK within tSRCDisconnect:
 - a. PUT stops sourcing Vbus within tVbusOFF [TD.4.7.4.V.10]
 - b. PUT data communication has ceased. [TD.4.7.4.V.9]

TD 4.7.5 Try. SNK DRP Connect Sink Test

- A. Purpose:
 1. Verify a Try.SNK DRP transitions to Attached.SRC state with SNK
- B. Applicability:
 1. This test applies when VIF field Type_C_State_Machine is DRP and Type_C_Implements_Try_SNK is YES
- C. Asserts:
 1. TBD
- D. Conditions:
 1. CVS emulates a SNK receptacle connector [TD.4.7.5.C.4]
 2. CVS emulates USB PD 2.0 5A Active Cable [TD.4.7.5.C.1]
 3. CVS emulates USB PD 3.0 5A Active Cable [TD.4.7.5.C.2]
 4. CVS emulates USB4 re-driver cable (ID Header Product Type = Passive, Cable VDO indicate Vconn required, TBT3 SVID / Mode supported and mode indicates Active Cable) [TD.4.7.5.C.3]
- E. Procedure:
 1. If VIF field Captive_Cable is set to YES, CVS emulates a receptacle as per condition 1 in Section D above, otherwise CVS emulates an Active cable as per condition 2
 2. If VIF field Type_C_Vconn_Source is NO, CVS verifies the PUT does not source Vconn for the remainder of the test. [TD.4.7.5.V.1]
 3. CVS transitions to Unattached.SNK
 - a. For a PUT_R, CVS also applies Ra on one CC
 4. CVS waits 5ms
 5. CVS verifies PUT presents Rp within max dcSRC.DRP x maxtDRP [TD.4.7.5.V.2]
 6. CVS transitions to AttachWait.SNK
 7. CVS verifies:
 - a. PUT keeps Rp attached since step 5 for tCCDebounce [TD.4.7.5.V.3]
 - b. PUT removes Rp and presents Rd for tDRPTry + tPDDebounce [TD.4.7.5.V.4]
 - c. PUT removes Rd and presents Rp for tPDDebounce [TD.4.7.5.V.5]
 8. CVS verifies PUT and CVS transition to Attached.SRC and Attached.SNK:
 - a. PUT sources Vbus within tVbusON [TD.4.7.5.V.6]

- b. PUT sources current at the level it advertises with Type-C Current. [TD.4.7.5.V.7]
 - c. Vconn_tested = false
 - d. If PUT supports USB PD:
 - i. CVS verifies that:
 - 01 PUT stabilizes VBUS before initiating USB PD communications [TD.4.7.5.V.8]
 - 02 CVS and PUT negotiate a contract. [TD.4.7.5.V.9]
 - ii. If PUT source capabilities include a Max Current > 3 A:
 - 01 CVS verifies that for a PUT_R, it supplies Vconn within tVconnON [TD.4.7.5.V.10]
 - 02 Vconn_tested = true
 - e. If PUT supports USB 3.1 DFP:
 - i. CVS verifies that:
 - 01 PUT attaches eSS terminations before Vbus on or within 80ms of Vbus on [TD.4.7.5.V.11]
 - 02 For a PUT_R and not Vconn_tested:
 - 1. It supplies VCONN within tVCONN [TD.4.7.5.V.12]
 - 2. Vconn_tested = true
 - 03 PUT transmits LFPS within 121ms of attaching eSS terminations OR transmits Warm Reset within 2s of attaching eSS terminations [TD.4.7.5.V.13]
 - 04 After eSS terminations are applied, and prior to PD Enter Mode negotiation if applicable, the SBU pins on the PUT are within zSBUTermination [TD.4.7.5.V.14]
 - ii. CVS loads 1W on Vconn
 - iii. CVS waits 1s
 - f. Else if PUT supports USB 2.0:
 - i. PUT starts data communications on its D+/D- pair. [TD.4.7.5.V.15]
 - g. If the PUT is a PUT_V and not Vconn_tested:
 - i. CVS verifies that for a PUT_R, it supplies Vconn within tVconnON [TD.4.7.5.V.16]
9. CVS transitions to Disabled
10. CVS verifies that PUT transitions to Unattached.SNK within tSRCDisconnect:
 - a. PUT stops sourcing Vbus within tVbusOFF [TD.4.7.5.V.20]
 - b. If PUT supports USB 3.1 DFP, it sourced Vconn up until after step 9 [TD.4.7.5.V.17]
 - c. PUT data communication has ceased. [TD.4.7.5.V.18]
 - d. PUT attaches Rd on its CC pins. [TD.4.7.5.V.19]
11. If VIF field Captive_Cable is NO, the CVS continues the test with step 2, using the next Condition from section D above

TD 4.7.6 Try.SNK DRP Connect SNKAS Test

- A. Purpose:
 - 1. Verify a Try.SNK PUT transitions to Attached.SRC correctly with SNKAS
- B. Applicability
 - 1. This test is required when VIF field Type_C_State_Machine is DRP and Type_C_Implements_Try_SNK is YES
- C. Asserts:

1. TBD
- D. Procedure:
 1. CVS transitions to Unattached.SNK
 2. CVS waits 5ms
 3. CVS monitors CCs for Rp and verifies that Rp is connected within max dcSRC.DRP x max tDRP. [TD.4.7.6.V.1]
 4. CVS transitions to AttachWait.SNK
 5. CVS verifies that PUT removes Rp and attaches Rd after tCCDebounce (transitions to Try.SNK) [TD.4.7.5.V.2]
 6. CVS transitions to Unattached.SNK after max tPDDebounce, then Unattached.Accessory after min tDRP x min dcSRC.DRP
 7. If PUT is a PUT_C with Ra on its plug's Vconn pin:
 - a. Complete steps 16 – 18.
 - b. Skip to step 10.
 8. CVS toggles between Unattached.SNK and Unattached.Accessory for tDRPTry
 9. CVS verifies PUT attaches Rp after CVS transitions to Unattached.SNK for tPDDebounce [TD.4.7.5.V.3]
 10. CVS verifies PUT and CVS transition to Attached.SRC and Attached.SNK after tPDDebounce:
 - a. PUT sources Vbus within tVbusOn [TD.4.7.5.V.4]
 - b. If PUT supports PD messaging:
 - i. PUT and CVS negotiate an explicit contract [TD.4.7.5.V.5]
 - c. If PUT supports USB 3.1
 - i. PUT starts USB communications on its SS pairs [TD.4.7.5.V.6]
 - d. If PUT supports USB 2.0
 - i. PUT starts USB communications on its D+/D- pair [TD.4.7.5.V.7]
 11. CVS transitions to Disabled for 750ms
 12. CVS verifies PUT transitions to Unattached.SNK before tVBUSOFF expires:
 - a. PUT data communication has ceased [TD.4.7.5.V.8]
 13. If the PUT is not a PUT_R the test is over.
 14. CVS attaches Ra to one CC to appear as an Emarked Cabled for the remainder of the test
 15. Repeat steps 1-6.
 16. CVS transitions to PoweredAccessory after max tCCDebounce
 17. If PUT has VIF field Type_C_Is_Vconn_Powered_Accessory set to YES:
 - a. CVS verifies that PUT responds to PD signaling [TD.4.7.5.V.9]
 - b. CVS transitions to Disabled for 750ms
 - c. CVS transitions to Unattached.SNK
 18. Else Type_C_Is_Vconn_Powered_Accessory set to NO:
 - a. CVS transitions to Try.SNK and starts tDRPTry
 - b. CVS verifies PUT transitions to TryWait.SRC after tPDDebounce [TD.4.7.5.V.10]
 19. Repeat steps 10-12.

All DRPs Tests

These tests are for USB Type-C Connectors that implement the USB Type-C DRP Connection State Diagram in Figure 4-16 and variations shown in Figure 4-17. USB Type-C Chargers and DFPs that Sink are required to pass these tests.

TD 4.8.1 DRP Connect Audio Accessory Test

- A. Purpose:
 - 1. This test verifies that a DRP can connect with an Audio Accessory according to the USB Type-C spec requirements.
- B. Applicability:
 - 1. This test is required for a PUT_R with VIF field Type_C_State_Machine is DRP and Captive_Cable is NO
- C. Asserts
 - 1. 4.5.2.2.6.2#2
 - 2. 4.5.2.2.14.1#1-3
 - 3. 4.5.2.2.14.2#1
 - 4. 4.5.2.2.15.1#1-5
 - 5. 4.5.2.2.15.2#1
- D. Procedure:
 - 1. CVS present an Audio Accessory by terminating CC pins with Ra
 - 2. CVS verifies PUT transitions to Unattached.SRC within tDRP – (dcSRC.DRP x tDRP) [TD.4.8.1.V.1]
 - 3. If VIF field Type_C_Supports_Audio_Accessory is YES:
 - a. CVS verifies PUT transition to AudioAccessory within tCCDebounce
 - i. The PUT reconfigures its pins as defined in Appendix A [TD.4.8.1.V.2]
 - ii. The PUT does not drive VBUS or VCONN [TD.4.8.1.V.2]
 - iii. If the PUT sinks current over VBUS, it shall not be more than 500mA [TD.4.8.1.V.3]
 - iv. The PUT applies Rp on at least one CC [TD.4.8.1.V.4]
 - 4. If VIF field Type_C_Supports_Audio_Accessory is NO:
 - a. Wait tAMETimeout
 - b. CVS verifies that no Attached state is reached. [TD.4.8.1.V.5]
 - 5. CVS transitions to Disabled
 - 6. If VIF field Type_C_Supports_Audio_Accessory is YES:
 - a. CVS verifies PUT transitions to Unattached.SRC or Disabled within tCCDebounce.
 - i. PUT CCs are terminated with Rp or not terminated [TD.4.8.1.V.6]

TD 4.8.2 DRP Connect Debug Accessory Test

- A. Purpose:
 - 1. This test verifies that a DRP can connect to a Debug Accessory as appropriate.
- B. Applicability:
 - 1. This test is applicable when VIF field Type_C_State_Machine set to DRP and Captive_Cable is NO
- C. Asserts
 - 1. 4.5.2.2.16.1#1-3
 - 2. 4.5.3.3.16.2#2
 - 3. 4.5.2.2.19.1#2
- D. Procedure:
 - 1. CVS present a DTS (Debug and Test Accessory) Sink by terminating CC pins with Rd
 - 2. CVS verifies PUT transitions to Unattached.SRC within tDRP – (dcSRC.DRP x tDRP) [TD.4.8.2.V.1]
 - 3. If VIF field Type_C_Is_Debug_Target_SRC is YES:
 - a. CVS verifies PUT sources Vbus after tCCDebounce and within tVbusON. [TD.4.8.2.V.2]
 - 4. Else if VIF field Type_C_Is_Debug_Target_SRC is NO or not defined:

- a. CVS verifies PUT does not source Vbus after tCCDebounce expires. [TD.4.8.2.V.3]

TD 4.8.3 DRP Connect Vconn Accessory Test

- A. Purpose:
 - 1. Verify DRP that supports Alternate Modes attaches to a VCONN powered Accessory as described in the spec
- B. Applicability:
 - 1. This test is applicable when VIF field Type_C_State_Machine set to DRP and Captive_Cable is NO
- C. Asserts
 - 1. See TD 4.4.8
- D. Procedure:
 - 1. CVS presents 1 CC pin in the vRa range and one in rRd like a VCONN powered Accessory.
 - 2. CVS verifies the PUT transitions to Unattached.SRC within tDRP – (dcSRC.DRP x tDRP). [TD.4.8.3.V.1]
 - 3. If VIF field Type_C_Implements_Try_SNK is YES:
 - a. CVS verifies:
 - i. PUT transitions to Try.SNK within tCCDebounce [TD.4.8.3.V.2]
 - ii. PUT transitions to TryWait.SRC within tTryCCDebounce + tDRPTry after entering Try.SNK [TD.4.8.3.V.3]
 - 4. CVS verifies that PUT transitions to Attached.SRC:
 - a. If VIF field Type_C_Implements_Try_SNK is YES:
 - i. PUT sources Vbus after tTryCCDebounce and before tTryCCDebounce + tVbusON expires [TD.4.8.3.V.4]
 - b. If VIF field Type_C_Implements_Try_SNK is NO:
 - i. PUT sources VBUS after tCCDebounce and before tCCDebounce + tVBUSON expires [TD.4.8.3.V.5]
 - c. PUT advertises VBUS capability over Rp [TD.4.8.3.V.6]
 - d. If the PUT supports PD:
 - i. PUT and CVS negotiate an explicit contract [TD.4.8.3.V.7]
 - e. If the PUT is a PUT_V:
 - i. PUT sources Vconn within tVconnON [TD.4.8.3.V.8]
 - ii. If PUT has VIF field Attempts_Discov_SOP set to YES:
 - 01 PUT initiates Alternate Mode discovery with Structured VDMs [TD.4.8.3.V.9]
 - 5. CVS transitions to Disabled
 - 6. CVS verifies the PUT transitions to Unattached.SNK within tSRCDisconnect.
 - a. PUT stops sourcing VCONN within tVCONNOFF [TD.4.8.3.V.10]
 - b. PUT stops sourcing Vbus within tVbusOFF [TD.4.8.3.V.11]
 - c. PUT attaches Rd on its CCs [TD.4.8.3.V.12]

Source-Capable Tests

These tests are for any USB Type-C connector that is capable of operating as a Source. Some tests are for connectors that support specific uses like USB PD or legacy connections. Read each test purpose and applicability carefully to determine if the test applies.

If the DUT VIF field `Type_C_State_Machine` is `SNK` and either `PD_Port_Type` is 1 (Consumer/Provider) or `Accepts_PR_Swap_As_Src` is `YES` or `Accept_PR_Swap_As_Snk` is `YES`, the following Source-Capable Tests are potentially applicable (also review individual test applicability rules):

- TD 4.9.1 Source Suspend Test
- TD 4.9.3 Source PR_Swap Test
- TD 4.9.4 Source Vconn_Swap Test
- TD 4.9.5 Source Alternate Modes Test

The CVS and PUT swap initial roles in each test to connect up to `Attached.SRC` and `Attached.SNK`. Then the CVS initiates `PR_Swap` and to transition the PUT into `Attached.SRC`. For `PUT_V`, the CVS will perform a PD `Vconn_Swap` request so that PUT is sourcing `Vconn`. For a PUT with VIF field `Type_C_Can_Act_as_Host` set to `YES`, the CVS will perform a `DR_Swap` so that the PUT is in `DFP` state. The CVS verifies that all swaps initiated at the beginning of the test are accepted within 10s. The CVS follows the test steps in each test from the point that the PUT enters `Attached.SRC`. Note that this type of product scheme is discouraged since it will defy user-expectation that the product will charge a dead battery.

TD 4.9.1 Source Suspend Test

- A. Purpose:
 - 1. Verify a Source that continues sourcing `VBUS` during suspend also continues sourcing `VCONN`.
- B. Applicability:
 - 1. This test is applicable when VIF field `Type_C_Can_Act_as_Host` is `YES` and `Host_Suspend_Supported` = `YES` and the PUT is a `PUT_V`
- C. Asserts:
 - 1. 4.6.1.2#1
- D. Procedure:
 - 1. CVS transitions to `Unattached.SNK`
 - 2. CVS presents `Ra` on one CC for the duration of the test and simulates an Emarked Active Cable connected on the CC.
 - 3. CVS and PUT transition through Type-C Connection States to `Attached.SNK` and `Attached.SRC`
 - 4. CVS verifies that the PUT sources `Vconn` within `tVconnON` [TD.4.9.1.V.1]
 - 5. CVS sinks 100 mW over `VCONN`
 - 6. If PUT is USB 3.1 capable:
 - a. CVS and PUT link to `U0`.
 - b. The Operator suspends the link using whatever method is available. If the PUT is attached to a PC, the Operator clicks a `USB3CV` prompt
 - c. CVS verifies that:
 - i. The CVS and PUT entered `SUSPEND` [TD.4.9.1.V.2]
 - ii. If the PUT still provides `VBUS`, it must also continue to source `VCONN` [TD.4.9.1.V.3]
 - d. The Operator resumes the link using whatever method is available.
 - 7. If PUT is USB 2.0 capable:
 - a. CVS and PUT enter `HS/FS/LS` Default state.
 - b. The Operator suspends the link using whatever method is available. If the PUT is attached to a PC, the Operator clicks a `USB31CV` prompt

- c. CVS verifies that:
 - i. The CVS and PUT entered SUSPEND [TD.4.9.1.V.4]
 - ii. If the PUT still provides VBUS, it must also continue to source VCONN [TD.4.9.1.V.5]
- d. The Operator resumes the link using whatever method is available.

TD 4.9.2 USB Type-C Current Advertisement Test

- A. Purpose:
 - 1. Verify a USB Type-C PUT advertises an Rp value in the legal range
 - 2. Verify a USB Type-C and PD PUT advertises an Rp of at least 1.5 A while a contract exists.
- B. Applicability:
 - 1. This test is applicable when VIF field Type_C_State_Machine is DRP or SRC
- C. Assert:
 - 1. 4.6#1
 - 2. 4.6.2.1#4
 - 3. 4.6.2.2#1
 - 4. 4.6.2.3#1,2
 - 5. 4.6.2.4#3
 - 6. 4.7#8
 - 7. 4.8.1#1-4
 - 8. 4.8.1.1#2
 - 9. 4.8.2#1
 - 10. 4.8.4#2
- D. Procedure:
 - 1. CVS transitions to Unattached.SNK
 - 2. CVS verifies that PUT applies Rp at a voltage range within vRd-USB or vRd-1.5 or vRd-3.0 range. [TD.4.9.2.V.1]
 - 3. CVS and PUT transition into Attached.SNK and Attached.SRC
 - 4. Wait tVbusON
 - 5. If VIF field BC_1_2_Support is 1 (“Charging Port”) or 3 (“Both”):
 - a. If the BC 1.2 PUT is capable of providing 1.5 A, CVS verifies Rp is in the vRd-1.5 or vRd-3.0 range. [TD.4.9.2.V.2]
 - 6. If the PUT supports USB PD:
 - a. CVS transitions to Disabled for 500ms.
 - b. CVS disables any USB PD transmission.
 - c. CVS transitions to Unattached.SNK with one CC terminating Ra
 - d. CVS and PUT transition into Attached.SNK and Attached.SRC
 - e. CVS reads PUT Source Capabilities.
 - i. For a PUT_R:
 - 01 CVS verifies no Source PDOs advertise more than 3 A current. [TD.4.9.2.V.3]
 - ii. If the PUT 5V PDO reports a max current of 3 A or higher:
 - 01 CVS checks Rp is in the vRd-3.0 range [TD.4.9.2.V.4]
 - iii. ELSE If the PUT 5V PDO reports a max current of 1.5 A or higher:
 - 01 CVS checks Rp is in the vRd-1.5 range [TD.4.9.2.V.5]
 - iv. ELSE If the PUT 5V PDO reports a max current of default or higher:
 - 01 CVS checks Rp is in the vRd-USB range. [TD.4.9.2.V.6]

- f. CVS transitions to Disabled
- g. Wait 750ms.
- h. CVS transitions to Unattached.SNK and applies Ra on one CC.
- i. CVS and PUT transition to Attached.SNK and Attached.SRC.
- j. CVS enables USB PD SOP and SOP' transmission.
- k. For a PUT_R:
 - i. CVS responds to PUT Discover Identity as a cable with a max current of 3 A.
 - ii. CVS verifies that PUT advertises Source Capabilities with a max current of 3 A or less. [TD.4.9.2.V.7]
- l. CVS verifies:
 - i. CVS and PUT successfully negotiate an Explicit Contract (5V at max current advertised). [TD.4.9.2.V.8]
 - ii. PUT advertises Rp in the 1.5 A or 3.0 A range. [TD.4.9.2.V.9]

TD 4.9.3 Source PR_Swap Test

- A. Purpose:
 - 1. Verify a PUT with PD PR_Swap support follows specification requirements
- B. Applicability:
 - 1. This test is applicable if VIF field Accepts_PR_Swap_As_Src is set to YES
- C. Asserts:
 - 1. 4.5.2.2.5.1#2,4,7
 - 2. 4.5.2.2.8.2#7,8
- D. Data Conditions:
 - 1. PUT supports USB 3.2 as DFP [TD.4.9.3.C.1]
 - 2. PUT supports USB 2.0 as DFP [TD.4.9.3.C.2]
- E. Procedure:
 - 1. CVS transitions to Unattached.SNK
 - 2. For a PUT_R, CVS terminates one CC pin with Ra for the duration of the test. CVS emulates an Emarker Active Cable on the CC terminated with Ra.
 - 3. CVS verifies PUT transitions to Attached.SRC [TD.4.9.3.V.1]
 - 4. CVS transitions to Attached.SNK.
 - 5. CVS and PUT initiate the next PUT supported Data Condition above if applicable.
Note: Once the CVS and PUT have established USB Data communications, the Operator maintains packet traffic between CVS and PUT via GetDescriptor() every 50ms through USB3CV.
 - 6. CVS verifies GetDescriptors are completed throughout the test [TD.4.9.3.V.2]
 - 7. CVS initiates and together with PUT completes PD PR_Swap request
 - 8. CVS verifies:
 - a. PUT terminates the CC to ground through Rd [TD.4.9.3.V.3]
 - b. PUT maintains data role [TD.4.9.3.V.4]
 - c. PUT stops supplying VBUS [TD.4.9.3.V.5]
 - d. PUT_V maintains VCONN supply [TD.4.9.3.V.6]
 - 9. CVS transitions to Disabled
 - 10. CVS verifies PUT transitions to Unattached before tVBUSOFF
 - a. If Type_C_State_Machine is SRC, CVS verifies PUT applies Rp [TD.4.9.3.V.7]
 - b. If Type_C_State_Machine is DRP or SNK, CVS verifies PUT applied Rd [TD.4.9.3.V.8]
 - 11. CVS continues to Step 1 until all PUT supported Data Conditions are exhausted

TD 4.9.4 Source VCONN Swap Test

- A. Purpose:
 - 1. Verifies a PUT that supports PD implements a VCONN swap according to requirements
- B. Applicability:
 - 1. This test is applicable to a PUT_V when VIF field VCONN_Swap_To_Off_Supported is YES
- C. Asserts:
 - 1. 4.5.2.2.8.1#12
 - 2. 4.5.2.2.8.1#13
 - 3. 4.5.2.2.8.1#14
- D. Conditions:
 - 1. CVS emulates USB PD Passive Cable [TD.4.9.4.C.1]
 - 1. CVS emulates USB PD Active Cable [TD.4.9.4.C.2]
 - 2. CVS emulates USB4 re-driver cable (ID Header Product Type = Passive, Cable VDO indicate Vconn required, TBT3 SVID / Mode supported and mode indicates Active Cable) [TD.4.9.4.C.3]
- E. Procedure:
 - 1. CVS transitions to Unattached.SNK
 - 2. For a PUT_R, CVS terminates one CC pin with Ra for the duration of the test.
 - 3. CVS verifies:
 - a. PUT transitions to Attached.SRC [TD.4.9.4.V.1]
 - b. PUT sources Vconn within tVconnON [TD.4.9.4.V.2]
 - 4. CVS transitions to Attached.SNK
 - 5. CVS and PUT complete the PD VCONN_Swap request
 - 6. CVS verifies that PUT responds to Vconn_Swap with accept within 10s of CVS first attempting a Vconn_Swap. [TD.4.9.4.V.7]
 - 7. If Condition 2 or 3 and the port supports USB 3.2 data, CVS verifies the PUT sources Vconn until after the CVS transmits PS_RDY [TD.4.9.4.V.5]
 - 8. If the PUT was sourcing VCONN when CVS initiated the swap request, CVS verifies the PUT stops sourcing VCONN within tVCONNOff after the CVS transmits PS_RDY [TD.4.9.4.V.3]
 - 9. If VIF field VCONN_Swap_To_On_Supported is YES:
 - a. CVS and PUT complete the PD VCONN_Swap request
 - b. CVS verifies the PUT responds to Vconn_Swap with accept within 10s of CVS first attempting a Vconn_Swap [TD.4.9.4.V.8]
 - c. CVS verifies the PUT starts sourcing VCONN before sending PS_RDY [TD.4.9.4.V.4]
 - d. If Condition 2 or 3 and the port supports USB 3.2:
 - i. CVS waits 1s
 - ii. CVS transitions to Disabled
 - iii. CVS verifies the PUT sourced Vconn until after step 8.c.ii [TD.4.9.4.V.6]

TD 4.9.5 Source Alternate Modes Test

- B. Purpose:
 - 1. Verifies a Source supports Alternate Modes according to requirements
- C. Applicability:

1. Test only applies to PUTs that support PD and Alternate Modes as indicated by VIF fields Type_C_Is_Alt_Mode_Controller set to YES
- D. Asserts:
1. E.1#1-3
 2. E.2#1
 3. E.2.1#1-4
 4. E.2.2#1-4,6
 5. E.2.2#5
 6. E.3#1
- E. CVS Supported Alternate Modes:
1. DisplayPort
 - a. Port Capability: 11b
 - b. Receptacle Indication: 1
 - c. USB 2.0 Signaling Not Used: 0
 - d. DP Sink Device Pin Assignments Supported: 00011100b
 - e. DP Source Device Pin Assignments Supported: 00011100b
- F. Data Conditions:
1. PUT supports USB 3.2 as DFP [TD.4.9.5.C.1]
 2. PUT supports USB 2.0 as DFP [TD.4.9.5.C.2]
 3. PUT does not support USB data as host [TD.4.9.5.C.3]
- G. Procedure:
1. CVS verifies VIF field Type_C_Can_Act_As_Host is YES [TD.4.9.5.V.1] (NOTE: Data Condition 3 is required so that products who set this field incorrectly will run the test and fail this step)
 2. CVS transitions to Unattached.SNK
 3. CVS attaches Ra to one CC for the duration of the test
 4. CVS verifies:
 - a. PUT transitions to AttachWait.SRC for tCCDebounce [TD.4.9.5.V.2]
 - b. PUT transitions to Attached.SRC [TD.4.9.5.V.3]
 5. CVS transitions to Attached.SNK
 6. CVS exposes a USB data interface using the next relevant Data Condition from above.
 7. Note: Once the CVS and PUT have established USB Data communications, the Operator maintains packet traffic between CVS and PUT via GetDescriptor() every 50ms through USB3CV. CVS verifies GetDescriptors are completed throughout the test, unless in USB 3.1 data condition and PUT has sent Enter Mode for a mode which uses all RX/TX pins [TD.4.9.5.V.4]
 8. CVS and PUT complete PD Explicit Power Contract.
 9. CVS verifies PUT does not send any Structured VDMs used for Alternate Modes discovery during PD Explicit Power Contract negotiation. [TD.4.9.5.V.5]
 10. CVS responds to all standard VDM requests with CVS Supported Alternate Mode 1 info
 11. If PUT sends Enter Mode:
 - a. CVS transitions to Alternate Mode 1 and ACKs the host.
 - b. CVS verifies:
 - i. PUT follows all electrical constraints for SBU and any reconfigured pins (i.e. USB Safe States). [TD.4.9.5.V.6]
 - ii. For a PUT_R, it follows all electrical constraints for VCONN [TD.4.9.5.V.7]
 - c. CVS transitions to Disabled.
 - d. CVS verifies PUT transition to Unattached within tSRCDisconnect:
 - i. If Type_C_State_Machine is DRP, CVS verifies PUT applies Rd [TD.4.9.5.V.8]
 - ii. If Type_C_State_Machine is SRC, CVS verifies PUT applies Rp [TD.4.9.5.V.9]
 - iii. PUT stops sourcing VBUS within tVBUSOFF [TD.4.9.5.V.10]

- iv. For a PUT_R, it stops sourcing VCONN within tVCONNOFF [TD.4.9.5.V.11]
- 12. Continue to step 1 with next CVS Supported Alternate Mode.
- 13. Continue to step 1 with next Data Condition.

Sink-Capable Tests

These tests are for a USB Type-C connector that is capable of operating as a Sink. Some tests are for connectors that support specific uses like USB PD, Alternate Modes, legacy connections or that use batteries. Read each test purpose carefully to determine if the test applies.

If the DUT VIF field Type_C_State_Machine is SRC and either PD_Port_Type is 2 (Provider/Consumer) or Accepts_PR_Swap_As_Src is YES or Accepts_PR_Swap_As_Snk is YES, the following Sink-Capable Tests are potentially applicable (also review individual test applicability rules):

- TD 4.10.3 Sink Suspend Test
- TD 4.10.4 Sink PR_Swap Test
- TD 4.10.5 Sink Vconn_Swap Test
- TD 4.10.6 Sink Alternate Mode Test

The CVS and PUT swap roles in each test to connect up to Attached.SNK and Attached.SRC. Then the CVS initiates PR_Swap to transition the PUT into Attached.SNK. For PUT_V, the CVS will perform a PD Vconn_Swap request so that CVS is not sourcing Vconn. For a PUT with VIF field Type_C_Can_Act_as_Device set to YES, the CVS will perform a DR_Swap to enter the UFP state. The CVS verifies that all swaps initiated at the beginning of the test are accepted within 10s. The CVS follows the test steps in each test from the point that the PUT enters Attached.SNK. For TD 4.10.3 Sink Suspend Test, the CVS follows the test steps starting at step C.14. For TD 4.10.6 Sink Alternate Mode Test, the CVS follows this startup method in the initial test steps and then again after step E.7. At step E.11 CVS also adds eSS or USB 2.0 terms to indicate that it is a data host.

TD 4.10.1 Sink Power Sub-States Test

- A. Purpose:
 - 1. Verify a Sink uses USB Type-C Current for initial power handshake
- B. Applicability:
 - 1. Test is applicable when VIF field Type_C_State_Machine is DRP or SNK
- C. Asserts:
 - 1. 4.5.2.3#1,2
 - 2. 4.5.2.3.1.1#1,2
 - 3. 4.5.2.3.1.2#1-3
 - 4. 4.5.2.3.2.1#1,2
 - 5. 4.5.2.3.2.2#1-3
 - 6. 4.5.2.3.3.1#1,2
 - 7. 4.5.2.3.3.2#1-3
 - 8. 4.6#1
 - 9. 4.6.2.1#1,6
- D. Data Conditions:
 - 1. PUT supports USB 3.1 as UFP [TD.4.10.1.C.1]
 - 2. PUT supports USB 2.0 as UFP [TD.4.10.1.C.2]
 - 3. PUT does not support USB as device [TD.4.10.1.C.3]
- E. Procedure:

1. CVS presents SS terminations and D+/D-
2. CVS transitions to Unattached.SRC state with vRd in vRd-USB range.
3. The CVS and PUT link to Attached.SRC and Attached.SNK. NOTE: CVS waits sufficiently after Attached.SNK detected to assure a Try.SRC PUT is securely in Attached.SNK.
4. If Type_C_Power_Source = 1 (UFP-powered) or 2 (Both), CVS saves default USB power according to PUT type:
 - a. If Type_C_Can_Act_As_Device is YES and Device_Speed is HS, default USB power is 100 mA.
 - b. If Type_C_Can_Act_As_Device is YES and Device_Speed is SS or above, default USB power is 150 mA
 - c. If Type_C_Can_Act_As_Device is NO, default USB power is 500 mA
5. If Type_C_Power_Source = 0 (Externally-powered), CVS verifies PUT draws < 1 mA for the duration of the test. [TD.4.10.1.V.1]
6. CVS verifies the PUT draws no more than default USB power since step 3. [TD.4.10.1.V.2]
7. CVS transitions vRd to vRd-1.5 range
8. CVS verifies:
 - a. The PUT draws no more than default USB power before min tPDDebounce. [TD.4.10.1.V.3]
 - b. The PUT draws no more than 1.5 amps after max tPDDebounce. [TD.4.10.1.V.4]
9. CVS transitions vRd to vRd-USB range
10. CVS verifies:
 - a. The PUT draws no more than default USB power after max tSinkAdj. [TD.4.10.1.V.5]
11. CVS transitions vRd to vRd-3.0 range
12. CVS verifies:
 - a. The PUT draws no more than default USB power before min tPDDebounce. [TD.4.10.1.V.6]
 - b. The PUT draws no more than 3.0 amps after max tPDDebounce. [TD.4.10.1.V.7]
13. CVS transitions vRd to vRd-1.5 range
14. CVS verifies:
 - a. The PUT draws no more than 1.5 amps after max tSinkAdj. [TD.4.10.1.V.8]
15. CVS transitions vRd to vRd-3.0 range
16. CVS verifies:
 - a. The PUT draws no more than 1.5 amps before min tPDDebounce [TD.4.10.1.V.9]
 - b. The PUT draws no more than 3.0 amps after max tPDDebounce [TD.4.10.1.V.10]
17. CVS transitions vRd to vRd-USB range
18. CVS verifies:
 - a. The PUT draws no more than default USB power after max tSinkAdj. [TD.4.10.1.V.11]
19. CVS transitions to Disabled for 200ms.
20. CVS presents SS terminations and D+/D-
21. CVS transitions to Unattached.SRC with vRd in the vRd-1.5 range.
22. The CVS and PUT link to Attached.SRC and Attached.SNK. NOTE: CVS waits sufficiently after Attached.SNK detected to assure a Try.SRC PUT is securely in Attached.SNK.
23. CVS verifies:
 - a. The PUT does not draw more than default USB power for min tPDDebounce. [TD.4.10.1.V.12]

- b. The PUT draws no more than 1.5 amps after max tPDDebounce. [TD.4.10.1.V.13]
- 24. If Condition 1:
 - a. CVS enumerates the PUT device at USB 3.1 Gen 1 speed stopping short of setting a configuration
 - b. For each configuration discovered during enumeration, if the configuration bMaxPower field is greater than 0, CVS verifies that the PUT draws no more than 150 mA. [TD.4.10.1.V.14]
 - c. CVS removes SS terminations.
- 25. If Condition 2:
 - a. CVS enumerates the PUT device at USB 2.0 stopping short of setting a configuration
 - b. For each configuration discovered during enumeration, if the configuration bMaxPower field is greater than 0, CVS verifies that the PUT draws no more than 100 mA. [TD.4.10.1.V.15]
- 26. CVS transitions to Disabled for 200ms.
- 27. CVS presents SS terminations and D+/D-
- 28. CVS transitions to Unattached.SRC with vRd in the vRd-3.0 range
- 29. CVS and PUT link to Attached.SRC and Attached.SNK
- 30. CVS verifies:
 - a. The PUT draws no more than default USB power before min tPDDebounce. [TD.4.10.1.V.16]
 - b. The PUT draws no more than 3.0 amps after max tPDDebounce. [TD.4.10.1.V.17]
- 31. If Condition 1:
 - a. CVS enumerates the PUT device at USB 3.1 Gen 1 speed stopping short of setting a configuration
 - b. For each configuration discovered during enumeration, if the configuration bMaxPower field is greater than 0, CVS verifies that the PUT draws no more than 150 mA. [TD.4.10.1.V.18]
 - c. CVS removes SS terminations.
- 32. If Condition 2:
 - a. CVS enumerates the PUT device at USB 2.0 stopping short of setting a configuration
 - b. For each configuration discovered during enumeration, if the configuration bMaxPower field is greater than 0, CVS verifies that the PUT draws no more than 100 mA. [TD.4.10.1.V.19]

TD 4.10.2 Sink Power Precedence Test

- A. Purpose:
 - 1. Verify a port receiving power negotiations from multiple avenues uses the correct precedence requirements
- B. Applicability:
 - 1. This test is applicable when VIF field Type_C_State_Machine is DRP or SNK
- C. Asserts
 - 1. 4.6#2-4
 - 2. 4.6.2.1#2
- D. Procedure:
 - 1. CVS transitions to Unattached.SRC advertising USB Default Current with Rp.
 - 2. CVS and PUT transition to Attached.SRC and Attached.SNK
 - 3. For a PUT_R, CVS emulates an Emarker cable capable of supporting 5A.
 - 4. If the PUT Supports USB 2.0 as a device:

- a. CVS enumerates the PUT device at HS
- b. For the first configuration discovered during enumeration, CVS sends SetConfiguration(iConfiguration)
- c. If Type_C_Power_Source = 0 (Externally-powered), CVS verifies:
 - i. The PUT draws < 1 mA over Vbus [TD.4.10.2.V.1]
 - ii. USB configuration bmAttributes bit D6 is set to 1 [TD.4.10.2.V.2]
 - iii. USB configuration field bMaxPower is set to 0 [TD.4.10.2.V.3]
- d. If Type_C_Power_Source = 1 (UFP-powered), CVS Verifies:
 - i. The PUT draws no more than the maximum power consumption indicated in the bMaxPower field. [TD.4.10.2.V.4]
 - ii. USB configuration bmAttributes bit D6 is set to 0 [TD.4.10.2.V.5]
 - iii. USB configuration field bMaxPower is greater than 0 [TD.4.10.2.V.6]
- e. If Type_C_Power_Source = 2 (Both), CVS verifies:
 - i. If USB configuration field bMaxPower is set to 0, the PUT draws < 1 mA over Vbus. [TD.4.10.2.V.7]
 - ii. If USB configuration field bMaxPower is set greater than 0, the PUT draws no more than the maximum power consumption indicated in the bMaxPowerField. [TD.4.10.2.V.8]
- f. Continue to step 4.b and use the next configuration. After the last configuration, continue to the next step.
5. If VIF field BC_1_2_Supports is 1 (“Portable Device”) or 3 (“Both”):
 - a. CVS verifies it detects VDP_SRC on D+ within 1s [TD.4.10.2.V.9]
 - b. CVS provides VDM_SRC on D- while VDP_SRC is present
 - c. CVS verifies Sink draws current within BC 1.2 power requirements. [TD.4.10.2.V.10]
6. CVS advertises vRd-3.0 on its Rp.
7. CVS verifies the Sink draws up to 3 A [TD.4.10.2.V.11]
8. CVS transitions to Disabled for 200ms.
9. CVS transitions to Unattached.SRC with Rp in the vRd-USB range
10. CVS and PUT transition to Attached.SRC and Attached.SNK
11. If the PUT supports USB 3.1 as a device:
 - a. CVS enumerates the PUT device at USB 3.1 Gen 1 speed.
 - b. For the first configuration discovered during enumeration, CVS sends SetConfiguration(iConfiguration)
 - c. If Type_C_Power_Source = 0 (Externally-powered), CVS verifies:
 - i. The PUT draws < 1 mA over Vbus [TD.4.10.2.V.12]
 - ii. USB configuration bmAttributes bit D6 is set to 1 [TD.4.10.2.V.13]
 - iii. USB configuration field bMaxPower is set to 0 [TD.4.10.2.V.14]
 - d. If Type_C_Power_Source = 1 (UFP-powered), CVS Verifies:
 - i. The PUT draws no more than the maximum power consumption indicated in the bMaxPower field. [TD.4.10.2.V.15]
 - ii. USB configuration bmAttributes bit D6 is set to 0 [TD.4.10.2.V.16]
 - iii. USB configuration field bMaxPower is greater than 0 [TD.4.10.2.V.17]
 - e. If Type_C_Power_Source = 2 (Both), CVS verifies:
 - i. If USB configuration field bMaxPower is set to 0, the PUT draws < 1 mA over Vbus. [TD.4.10.2.V.18]
 - ii. If USB configuration field bMaxPower is set greater than 0, the PUT draws no more than the maximum power consumption indicated in the bMaxPowerField. [TD.4.10.2.V.19]
 - f. Continue to step 4.b and use the next configuration. After the last configuration, continue to the next step.
12. If the PUT supports BC 1.2:

- a. CVS verifies it detects VDP_SRC on D+ within 1s [TD.4.10.2.V.20]
 - b. CVS provides VDM_SRC on D- while VDP_SRC is present
 - c. CVS verifies Sink draws current within BC 1.2 power requirements. [TD.4.10.2.V.21]
13. CVS advertises vRd-3.0 on its Rp.
14. CVS verifies the Sink draws up to 3 A [TD.4.10.2.V.22]
15. If the PUT supports USB PD:
- a. CVS advertises vRd-1.5 on its Rp and a Source Capabilities PDO with 5V 1.5A
 - b. CVS verifies:
 - i. PUT and CVS establish a contract [TD.4.10.2.V.23]
 - ii. After tSinkAdj expires the PUT draws no more than 1.5A [TD.4.10.2.V.24]
 - c. If PUT supports USB 3.1 as a device:
 - i. CVS sends Warm Reset and enumerates the PUT device
 - ii. For each configuration discovered during enumeration, CVS verifies:
 - 01 The configuration bmAttributes bit D6 is set to 1 [TD.4.10.2.V.25]
 - 02 The configuration bMaxPower field is set to 0 [TD.4.10.2.V.26]
 - iii. CVS removes SS terminations.
 - d. If PUT supports USB 2.0 as a device:
 - i. CVS resets and enumerates the PUT device at USB 2.0.
 - ii. For each configuration discovered during enumeration, CVS verifies:
 - 01 The configuration bmAttributes bit D6 is set to 1 [TD.4.10.2.V.27]
 - 02 The configuration bMaxpower field is set to 0 [TD.4.10.2.V.28]
 - e. CVS advertises vRd-3.0 on its Rp
 - f. CVS verifies the Sink does not draw more than 1.5A current after tSinkAdj + 500ms expires. [TD.4.10.2.V.29]
 - g. CVS transmits a PD Hard Reset.
 - h. CVS advertises vRd-USB on its Rp
 - i. CVS does not communicate via PD messaging after Hard Reset and D+/D- terminations are present.
 - j. CVS verifies:
 - i. If Type_C_Can_Act_As_Device is YES and Device_Speed is HS, CVS verifies that PUT sinks no more than 100 mA after tSinkAdj. [TD.4.10.2.V.30]
 - ii. If Type_C_Can_Act_As_Device is YES and Device_Speed is SS or above, CVS verifies that PUT sinks no more than 150 mA after tSinkAdj. [TD.4.10.2.V.31]
 - iii. If Type_C_Can_Act_As_Device is NO, CVS verifies that PUT sinks no more than 500 mA after tSinkAdj. [TD.4.10.2.V.32]

TD 4.10.3 Sink Suspend Test

- A. Purpose:
 - 1. Verify a PUT correctly draws power during suspend state
- B. Applicability:
 - 1. This test is applicable when both of the following are true:
 - a. VIF field Type_C_State_Machine is DRP or SNK, or PD_Port_Type is 2 (Provider/Consumer).

- b. VIF field Type_C_Can_Act_As_Device is YES
- C. Asserts:
 - 1. 4.6.1.1#1
- D. Procedure:
 - 1. CVS transitions to Unattached.SRC
 - 2. CVS and PUT transition to Attached.SRC and Attached.SNK
 - 3. If the PUT is USB 3.1 Capable:
 - a. CVS presents ssrc, sstx terminations
 - b. CVS brings PUT through the Link-Up Initialization Sequence (LIS) as defined in the USB 3.1 Link Test Specification to U0.
 - c. CVS suspends the PUT to U3 with SetPortFeature(PLS=U3)
 - d. CVS verifies the PUT is in suspend until step 3.h [TD.4.10.3.V.1]
 - e. Wait 1 second
 - f. If the PUT implements BC 1.2 as a sink, CVS verifies the PUT draws suspend current up to 100mA. [TD.4.10.3.V.2]
 - g. Else, CVS verifies the PUT draws suspend current as defined in the USB 3.1 and 2.0 specs. [TD.4.10.3.V.3]
 - h. CVS removes ssrc, sstx.
 - 4. If the PUT is USB 2.0 Capable:
 - a. CVS brings PUT to the HS/FS/LS Default state.
 - b. CVS suspends PUT.
 - c. CVS verifies the PUT is in suspend until step 5. [TD.4.10.3.V.4]
 - d. Wait 1 second.
 - e. If the PUT implements BC 1.2 as a sink, CVS verifies the PUT draws suspend current up to 100mA. [TD.4.10.3.V.5]
 - f. Else, CVS verifies the PUT draws suspend current as defined in the USB 2.0 Spec. [TD.4.10.3.V.6]
 - 5. CVS transitions to Disabled
 - 6. CVS transitions to Unattached.SRC advertising vRd-1.5 with Rp
 - 7. If the PUT is USB 3.1 Capable:
 - a. CVS presents ssrc, sstx terminations and brings a 3.1 PUT through the LIS to U0.
 - b. CVS suspends the PUT to U3 with SetPortFeature(PLS=U3)
 - c. CVS verifies the PUT is in suspend until step 7.f [TD.4.10.3.V.7]
 - d. Wait 1 second
 - e. CVS verifies the PUT draws suspend current up to 1.5 amps. [TD.4.10.3.V.8]
 - f. CVS removes ssrc, sstx terminations.
 - 8. If the PUT is USB 2.0 Capable:
 - a. CVS brings PUT to the HS/FS/LS Default state.
 - b. CVS suspends PUT.
 - c. CVS verifies the PUT is in suspend until step 9 [TD.4.10.3.V.9]
 - d. Wait 1 second
 - e. CVS verifies the PUT draws suspend current up to 1.5 amps. [TD.4.10.3.V.10]
 - 9. CVS transitions to Disabled
 - 10. CVS transitions to Unattached.SRC advertising vRd-3.0 with Rp
 - 11. If the PUT is USB 3.1 Capable:
 - a. CVS present ssrc, sstx terminations and brings a 3.1 PUT through the LIS to U0.
 - b. CVS suspends the PUT to U3 with SetPortFeature(PLS=U3)
 - c. CVS verifies the PUT is in suspend until step 11.f [TD.4.10.3.V.11]
 - d. Wait 1 second
 - e. CVS verifies the PUT draws suspend current up to 3 amps. [TD.4.10.3.V.12]
 - f. CVS removes ssrc, sstx terminations
 - 12. If the PUT is USB 2.0 Capable:
 - a. CVS brings PUT to the HS/FS/LS Default state.
 - b. CVS transitions PUT to SUSPEND.

- c. CVS verifies PUT is in suspend until step 13 [TD.4.10.3.V.13]
- d. Wait 1 second
- e. CVS verifies the PUT draws suspend current up to 3 amps. [TD.4.10.3.V.14]
- 13. CVS transitions to Disabled
- 14. If the PUT is PD Capable:
 - a. If VIF field Type_C_Port_On_Hub is YES, CVS prompts the test operator to enter the number of DFP ports on the hub, and CVS notes the number as nHubDFP. CVS then saves $pSuspend = 25 + (25 * \min(4, nHubDFP))$ mW.
 - b. Else CVS saves $pSuspend = 25$ mW.
 - c. CVS transitions to Unattached.SRC advertising vRd-3.0 with Rp
 - d. CVS negotiates largest current draw contract available from Sink PUT with PD. CVS indicates in its Source Capabilities that it supports USB Suspend.
Note: If the PUT is USB 3.1 capable, run step 14.b concurrently to 14.c.i, or the PUT may drop to eSS.Disabled since it does not see a link partner.
 - e. If the PUT is USB 3.1 capable:
 - i. CVS presents ss terminations and brings a 3.1 PUT through the LIS to U0.
 - ii. CVS suspends PUT to U3 with SetPortFeature(PLS=U3)
 - iii. CVS verifies the PUT is in suspend until the end of test [TD.4.10.3.V.15]
 - iv. CVS verifies PUT draws power $\leq pSuspend$ [TD.4.10.3.V.16]
 - f. If the PUT is USB 2.0 capable:
 - i. CVS brings PUT to the HS/FS/LS Default state.
 - ii. CVS transitions PUT to SUSPEND
 - iii. CVS verifies PUT is in suspend until the end of test [TD.4.10.3.V.17]
 - iv. Wait 1 second
 - v. CVS verifies PUT draws power $\leq pSuspend$ [TD.4.10.3.V.18]

TD 4.10.4 Sink PR_Swap Test

- A. Purpose:
 - 1. Verify that a Sink and Source Capable PUT transitions between Sink and Source correctly according to USB Type-C Connection State Machine
- B. Applicability:
 - 1. This test is applicable when VIF field Accepts_PR_Swap_As_Snk is YES
- C. Asserts:
 - 1. 4.5.2.2.5.1#4,7
 - 2. 4.5.2.2.5.2#2-3
 - 3. 4.5.2.2.8.1#3,11
- D. Data Conditions:
 - 1. PUT supports USB 3.1 as UFP [TD.4.10.4.C.1]
 - 2. PUT supports USB 2.0 as UFP [TD.4.10.4.C.2]
- E. Procedure:
 - 1. CVS transitions to Unattached.SRC
 - 2. For a PUT_R, CVS terminates one CC pin with Ra for the duration of the test.
 - 3. CVS verifies PUT transitions to Unattached.SNK for tCCDebounce [TD.4.10.4.V.1]
 - 4. CVS transitions to Attached.SRC
 - 5. CVS verifies PUT transitions to Attached.SNK. [TD.4.10.4.V.2]
 - 6. CVS and PUT initiate the next PUT supported Data Condition above if applicable. Note: CVS maintains traffic with PUT by sending GetDescriptor() every 50ms
 - 7. CVS verifies that GetDescriptors() are completed until step 11 [TD.4.10.4.V.3]

8. CVS initiates and together with PUT completes PD PR_Swap. Note: Please retry if PUT responds with Wait message for up to 10 seconds
9. CVS verifies:
 - a. PUT sources current and asserts Rp on the CC pin connected to the cable [TD.4.10.4.V.4]
 - b. For a PUT_R it does not source VCONN. [TD.4.10.4.V.5]
 - c. PUT maintains its data role [TD.4.10.4.V.6]
10. CVS waits 500ms
11. CVS transitions to Disabled
12. CVS verifies PUT transitions to Unattached within tDetach.
 - a. If Type_C_State_Machine is SRC, CVS verifies that Rp is applied [TD.4.10.4.V.7]
 - b. If Type_C_State_Machine is DRP or SNK, CVS verifies that Rd is applied [TD.4.10.4.V.8]
 - c. PUT stops sourcing VBUS within tVBUSOFF (Vbus reaches vSafe0V) [TD.4.10.4.V.9]
13. Continue to step one until all supported Data Conditions are exhausted.

TD 4.10.5 Sink VCONN_Swap Test

- A. Purpose:
 1. Verify a port sourcing VCONN removes it according to spec requirements.
- B. Applicability:
 1. This test is applicable when VIF field VCONN_Swap_To_On_Supported is YES
- C. Assert:
 1. 4.5.2.2.5.1#8
 2. 4.5.2.2.5.1#9
 3. 4.5.2.2.5.1#10
- D. Conditions
 1. CVS emulates USB PD Passive Cable [TD.4.10.5.C.1]
 2. CVS emulates USB PD Active Cable [TD.4.10.5.C.2]
 3. CVS emulates USB4 re-driver cable (ID Header Product Type = Passive, Cable VDO indicate Vconn required, TBT3 SVID / Mode supported and mode indicates Active Cable) [TD.4.10.5.C.3]
- E. Procedure:
 1. CVS transitions to Unattached.SRC
 2. CVS terminates one CC pin with Ra for the duration of the test.
 3. CVS verifies PUT transitions to Unattached.SNK for tCCDebounce [TD.4.10.5.V.1]
 4. CVS transitions to Attached.SRC
 - a. If the PUT supports USB 3.2 data, CVS starts USB 3.2 communication
 5. CVS verifies PUT transitions to Attached.SNK [TD.4.10.5.V.2]
 6. CVS initiates and together with PUT advances through a PD VCONN_Swap transaction
 7. CVS verifies PUT sources VCONN before it sends a PS_RDY to the CVS as the final message in the VCONN_Swap transaction. [TD.4.10.5.V.3]
 8. If Condition 2 or 3 and PUT supports USB 3.2 data:
 - a. CVS waits 2s
 9. If VIF field VCONN_Swap_To_Off_Supported is YES:
 - a. CVS initiates and together with PUT completes a PD VCONN_Swap transaction. [TD.4.10.5.V.4]
 - b. CVS verifies the PUT stops sourcing VCONN within tVCONNOff after the CVS sends the PS_RDY to the CVS as the final message in the VCONN_Swap transaction. [TD.4.10.5.V.5]

- c. If Condition 2 or 3 and PUT supports USB 3.2 data, CVS verifies the PUT sources Vconn until after CVS sends the PS_RDY [TD.4.10.5.V.6]
10. If VIF field VCONN_Swap_To_Off_Supported is NO and (Condition 2 or 3) and PUT supports USB 3.2 data:
 - a. CVS transitions to Disabled
 - b. CVS verifies the PUT stops sourcing VCONN within tVCONNOFF [TD.4.10.5.V.7]
 - c. If Condition 2 or 3 and PUT supports USB 3.2 data, CVS verifies the PUT sources Vconn until after CVS transitioned to Disabled [TD.4.10.5.V.8]

TD 4.10.6 Sink Alternate Mode Test

- A. Purpose:
 1. Verify a PUT that supports Alternate Mode follows spec requirements
- B. Applicability:
 1. This test is applicable when VIF field USB_PD_Support is set to YES and Type_C_State Machine is not set to SRC
 2. This test is applicable when VIF field USB_PD_Support set to YES and Type_C_State_Machine is set to SRC and DR_Swap_To_UFP_Supported is set to YES
- C. Asserts:
 1. E.1#1-3
 2. E.2#1-4
 3. E.2.1#1-4
 4. E.2.2#1-4,6
 5. E.2.2#5
 6. E.3#1
- D. Data Conditions:
 1. PUT supports USB 3.1 as a UFP and Type_C_Port_On_Hub is NO [TD.4.10.6.C.1]
 2. PUT supports USB 2.0 as a UFP [TD.4.10.6.C.2]
 3. PUT has Type_C_Can_Act_As_Device set to NO. [TD.4.10.6.C.3]
- E. Procedure:
 1. CVS transitions to unattached SRC.
 - a. CVS applies Ra on one CC if VIF field Captive_Cable is set to NO.
 2. CVS and PUT transition to Attached states and negotiate a PD power contract.
 3. CVS sends the Discover Identity message.
 4. If PUT responds to the message with an ACK and with the “Modal Operation Supported field set to YES, CVS verifies:
 - a. That VIF field Type_C_Is_Alt_Mode_Adapter is YES [TD.4.10.6.V.1]
 - b. That VIF field Modal_Operation_Supported_SOP is set to YES [TD.4.10.6.V.14]
 5. CVS sends the Discover SVIDs message.
 6. CVS verifies:
 - a. That if the Modal Operation Supported field is set to YES, then the PUT responds with one or more SVIDs [TD.4.10.6.V.15]
 - b. That if the Modal Operation Supported field is set to NO or the Discover Identity message is not ACK’ed, no SVIDs are returned. [TD.4.10.6.V.16]
 7. CVS transitions to Disabled for 500ms.
 8. If the Modal Operation Supported Field in the Discover Identity ACK is set to NO or the Discover Identity message is not ACK’ed, and no SVIDs are returned, the test is over.
 9. CVS transitions to Unattached.SRC
 10. CVS verifies PUT transitions to Unattached.SNK for tCCDebounce [TD.4.10.6.V.2]

11. CVS presents D+/D- and SS terminations as applicable to next relevant Data Condition from above
12. CVS transitions to Attached.SRC
13. CVS verifies PUT transitions to Attached.SNK. [TD.4.10.6.V.3]
14. CVS starts tAMETimeout timer.
15. CVS initiates and together with PUT completes PD Explicit Power Contract.
16. If the PUT field Type_C_Port_On_Hub is YES, CVS verifies that PUT starts USB communications within 1 second of CVS presenting terminations. [TD.4.10.6.V.4] Note that this state may be entered before or after the PD contract. If PUT goes to SS.Disabled or Compliance mode, CVS will issue Warm Reset to recover device.
17. CVS maintains packet traffic with PUT via GetDescriptor() every 50ms.
18. CVS verifies PUT exposes USB Billboard Device Class Interface in Descriptor after tAMETimeout and before tAMETimout + 500ms. [TD.4.10.6.V.5] Note: If VIF field Type_C_Port_On_Hub is YES, CVS looks for the exposed USB Billboard Device Class Interface in the descriptors of a downstream port on the hub product with a relative address from the hub UFP as defined in the VIF field Hub_Billboard_DSPort_Num. In this case, CVS verifies the first status change indicator for the Billboard Device is received after tAMETimeout and before tAMETimeout + 500ms.
19. If the PUT field Type_C_Port_on_Hub is NO, CVS verifies that the host is notified about the updated descriptors through PUT terminations. [TD.4.10.6.V.13] Note: Non-hub UFPs may hold off the enumeration process until tAMETimeout expires or enumerate before and then reset after tAMETimeout. UFPs may not respond to GetDescriptors continuously and update descriptors along the way – they must provoke a new GetDescriptor from a host using device terminations.
20. CVS sends Discover ID, SVID, and Modes to get the Alternate Modes that PUT supports.
21. CVS sends Enter Mode for a PUT supported Alternate Mode. If VIF field SVID<X>_Mode<Y>_Require_VDO = YES, CVS adds VIF field SVID<X>_Mode<Y>_Enter_VDO to the VDM.
22. CVS verifies:
 - a. The PUT successfully enters the Alternate Mode with PD messaging before ACKing [TD.4.10.6.V.6]
 - b. PUT follows all electrical constraints for SBU and any reconfigured pins (i.e. USB Safe State or USB data after receiving Enter Mode. ACK sent after pins reconfigured for Alt Mode). [TD.4.10.6.V.7]
 - c. For a PUT_R, it follows all electrical constraints for VCONN [TD.4.10.6.V.8]
23. CVS waits 1s
24. CVS sends Exit Mode for the Alternate Mode
25. CVS verifies:
 - a. The PUT successfully exits the Alternate Mode before sending the PD messaging response [TD.4.10.6.V.9]
 - b. PUT follows all electrical constraints for SBU and any reconfigured pins (i.e. USB Safe States or USB data before ACK sent). [TD.4.10.6.V.10]
26. CVS transitions to Disabled.
27. CVS verifies PUT transition to Unattached within tVBUSOFF
 - a. If Type_C_State_Machine is DRP or SRC, CVS verifies PUT applies Rp [TD.4.10.6.V.11]
 - b. If Type_C_State_Machine is SNK, CVS verifies PUT applies Rd [TD.4.10.6.V.12]
28. Continue to step 9 with next Data Condition above until supported Data Conditions are exhausted

Miscellaneous Tests

These tests don't belong in the other categories. The DR_Swap test is required for DRPs and DRDs. The Dead Battery Test is required for all battery-powered products.

TD 4.11.1 DR_Swap Test

Test is required for DRDs that do not implement Type-C DRPs and Type-C DRPs that implement USB communications as a Host or Device. Steps 1-9 are applicable for a Type-C Source as defined in Figure 4-12. Steps 10-15 are applicable for a Type-C Sink as defined in Figure 4-13. All steps are applicable to any port that supports both DR_Swaps as indicated in its VIF.

- A. Purpose:
 1. Verify a DRP supports DR_Swap
 2. Verify a Sinking DFP and Charging UFP support DR_Swap
 3. Verify a DRD supports DR_Swap
- B. Applicability:
 1. When VIF field Type_C_State_Machine is SNK or DRP and DR_Swap_To_DFP_Supported is YES, then test steps 1-10 are required.
 2. When VIF field field Type_C_State_Machine is SRC or DRP and DR_Swap_To_UFP_Supported is YES, then test steps 1, 11-17 are required.
 3. When VIF field Type_C_Can_Act_As_Host is YES and Type_C_Can_Act_As_Device is YES then:
 - a. When VIF field Type_C_State_Machine is SRC then test steps 1, 11-17 are required.
 - b. When VIF field Type_C_State_Machine is SNK then test steps 1-10 are required.
 4. When VIF field Type_C_State_Machine is DRP then:
 - a. When VIF field Type_C_Can_Act_As_Host is YES and Type_C_Can_Act_As_Device is NO then steps 1-10 are required.
 - b. When VIF field Type_C_Can_Act_As_Host is NO and Type_C_Can_Act_As_Device is YES then steps 1, 11-17 are required.
- C. Asserts:
 1. 4.8.3#2
 2. 4.8.4#3
- D. Procedure:

Swap to Host:

1. CVS monitors for D+/D- and SS terminations throughout the test
 - a. If VIF field Type_C_Can_Act_As_Host is YES and Type_C_Can_Act_As_Device is YES:
 - i. CVS verifies D+/D- pull-ups (device terminations) are present only when Vbus is present and DUT is in a UFP role [TD.4.11.1.V.1]
 - ii. CVS issues a Warning if SS terminations are present before Vbus is present [TD.4.11.1.V.2]
 - b. If VIF field Type_C_Can_Act_As_Host is YES and Type_C_Can_Act_As_Device is NO:
 - i. CVS verifies that D+/D- pull-ups (device terminations) are not present for the duration of the test. [TD.4.11.1.V.3]

- ii. CVS issues a Warning if SS terminations are present before Vbus is present [TD.4.11.1.V.4]
 - iii. CVS issues a Warning if SS terminations are present when DUT is in a UFP role [TD.4.11.1.V.5]
 - c. If VIF field Type_C_Can_Act_As_Host is NO and Type_C_Can_Act_As_Device is YES, CVS verifies D+/D- pull-ups (device terminations) and SS terminations are present only when Vbus is present and DUT is in a UFP role [TD.4.11.1.V.6]
 - d. If VIF field Type_C_Can_Act_As_Host is NO and Type_C_Can_Act_As_Device is NO, CVS verifies D+/D- pull-ups (device terminations) and SS terminations are not present for the duration of the test. [TD.4.11.1.V.7]
- 2. CVS transitions to Unattached.SRC
- 3. For a PUT_R, CVS terminates one CC pin with Ra for the duration of the test. CVS emulates an Emarker Active Cable on the pin.
- 4. CVS verifies PUT transitions to Unattached.SNK for at least tCCDebounce [TD.4.11.1.V.8]
- 5. CVS transitions to Attached.SRC
- 6. CVS verifies that PUT transitions to Attached.SNK by tDRPtry + tCCDebounce [TD.4.11.1.V.9]
- 7. CVS initiates and together with PUT completes a PD DR_Swap. Note: Please retry if PUT responds with Wait for up to 10 seconds.
- 8. CVS verifies that:
 - a. The PUT does not source VBUS [TD.4.11.1.V.10]
 - b. For a PUT_R, it does not source VCONN [TD.4.11.1.V.11]
 - c. The PUT maintains its CC termination [TD.4.11.1.V.12]
 - d. If VIF field Type_C_Can_Act_As_Host is YES:
 - i. The PUT USB 3.1 or 2.0 link starts Host communication [TD.4.11.1.V.13]
 - e. ELSE
 - i. The PUT USB 3.1 or 2.0 link has ceased signaling [TD.4.11.1.V.14]
- 9. If VIF field DR_Swap_To_UFP_Supported is YES:
 - a. CVS verifies that Type_C_Port_On_Hub is NO [TD.4.11.1.V.15]
 - b. CVS initiates and together with PUT completes a PD DR_Swap. Note: Please retry if PUT responds with Wait for up to 10 seconds.
 - c. CVS verifies that:
 - i. The PUT maintains its CC termination state [TD.4.11.1.V.16]
 - ii. If VIF field Type_C_Can_Act_As_Device is YES:
 - 01 The PUT USB 3.1 or 2.0 link starts Device communication [TD.4.11.1.V.17]
 - iii. ELSE
 - 01 The PUT USB 3.1 or 2.0 link has ceased signaling [TD.4.11.1.V.18]
- 10. CVS transitions to Disabled for 200ms

Swap to Device:

- 11. CVS transitions to Unattached.SNK
- 12. For a PUT_R, CVS terminates one CC pin with Ra for the duration of the test. CVS emulates an Emarker Active Cable on the pin.
- 13. CVS verifies that PUT transitions to Attach.SRC within tDRP.DRPAttach [TD.4.11.1.V.19]
- 14. CVS transitions to Attached.SNK
- 15. CVS initiates and together with PUT completes PD DR_Swap

16. CVS verifies that:
 - a. The PUT continues to source VBUS [TD.4.11.1.V.20]
 - b. For a PUT_V that was sourcing Vconn, it continues to source VCONN [TD.4.11.1.V.21]
 - c. The PUT maintains its CC termination [TD.4.11.1.V.22]
 - d. If VIF field Type_C_Can_Act_As_Device is YES:
 - i. The PUT USB 3.1 or 2.0 link starts Device communication [TD.4.11.1.V.23]
 - e. ELSE
 - i. The PUT USB 3.1 or 2.0 link has ceased signaling [TD.4.11.1.V.24]
17. If VIF field DR_Swap_To_DFP_supported is YES:
 - a. CVS verifies that Type_C_Port_On_Hub is NO [TD.4.11.1.V.25]
 - b. CVS initiates and together with PUT completes PD DR_Swap
 - c. CVS verifies that:
 - i. The PUT maintains its CC termination [TD.4.11.1.V.26]
 - ii. If VIF field Type_C_Can_Act_As_Host is YES:
 - 01 The PUT USB 3.1 or 2.0 link starts Host communication [TD.4.11.1.V.27]
 - iii. ELSE
 - 01 The PUT USB 3.1 or 2.0 link has ceased signaling [TD.4.11.1.V.28]

TD 4.11.2 Sink Dead Battery Test

- A. Purpose:
 1. Verify a PUT with a dead battery enters Unattached.SNK
- B. Applicability:
 1. This test is applicable to every USB Type-C Port (VIF field VIF_Product_Type is set to 0 (Port Product))
- C. Asserts:
 1. 4.5.2.2.3#1
 2. 4.8.5#1
- D. Procedure:
 1. CVS prompts the test operator to visually identify whether a battery is connected to the PUT
 - a. If operator answers YES, CVS verifies that VIF field Port_Battery_Powered is set to YES [TD.4.11.2.V.1]
 - b. If operator answers NO, CVS verifies that VIF field Port_Battery_Powered is set to NO. The test is over. [TD.4.11.2.V.2]
 2. CVS prompts the test operator to verify a dead battery is connected to the PUT. Note: For most cases (i.e. laptop, phone, flashlight, power bank) when the battery is “dead” it is not able to power the product’s function and needs to be recharged.
 3. CVS verifies that Rp is never applied on the PUT for the duration of the test [TD.4.11.2.V.3]
 4. If VIF field Type_C_State_Machine is SRC, CVS verifies that Rd is never applied on the PUT for the duration of the test [TD.4.11.2.V.6]
 5. CVS transitions to the Unattached.SRC state with Rp in vRd-USB.
 6. Wait for max tDRP timeout
 7. If VIF field Type_C_State_Machine is not SRC, CVS verifies that the PUT presents Rd termination on through CC pin. [TD.4.11.2.V.4]
 - a. For a PUT_R, check both CC pins for Rd

8. CVS presents VBUS
9. CVS waits 1 seconds
10. CVS verifies that the PUT current draw has not exceeded 500mA. [TD.4.11.2.V.5]
11. CVS transitions to Disabled.
12. CVS prompts the test operator to disconnect the dead battery and connect a charged battery if they wish to continue testing.

TD 4.11.3 Captive Cable Power Test

- A. Purpose:
 1. Verify a PUT_C draws the correct amount of Vconn power
- B. Applicability:
 1. This test is applicable to every USB Type-C Port (VIF field VIF_Product_Type is set to 0 (Port Product)) when Captive_Cable is set to YES and Captive_Cable_Is_Emarked is set to YES.
 - a. If the VIF field Type_C_State_Machine is set to SRC or DRP and VCONN_Swap_To_Off_Supported, then steps 1-3, 13-19 apply
 - b. If the VIF field Type_C_State_Machine is set to SNK or DRP, then steps 1-12 apply
- C. Asserts:
 1. TBD
- D. Conditions:
 1. CVS Vconn Source 3V [TD.4.11.3.C.1]
 2. CVS Vconn Source 5.5V [TD.4.11.3.C.2]
- E. Procedure:
 1. If VIF field Product_Type is set to Active Cable and VIF field Active_Cable_USB_Lanes is set to 1 (Two lanes), CVS verifies the PUT_C draws no more than 1.5W over Vconn for the duration of the test. [TD.4.11.3.V.1]
 2. If VIF field Product_Type is set to Active Cable and VIF field Active Cable USB Lanes is set to 0 (One lane), CVS verifies the PUT_C draws no more than 1W over Vconn for the duration of the test [TD.4.11.3.V.2]
 3. If VIF field Product_Type is set to Passive Cable, CVS verifies the PUT_C draws no more than 100mW over Vconn for the duration of the test. [TD.4.11.3.V.3]
 4. CVS attaches Rp on its CCs.
 5. CVS applies Vbus and Vconn Source when it enters Attached.SRC
 6. CVS sends Discover ID SOP'
 7. CVS verifies that it receives Discover ID SOP' Response. [TD.4.11.3.V.4]
 8. CVS negotiates a contract with the PUT_C and continues negotiations, accepting PR_Swaps and making best effort to provide the max power contract that the PUT_C offers / requests.
 9. If the PUT_C supports USB 3.2 data as a device, CVS enumerates the PUT_C with USB 3.2 messaging
 10. Else if the PUT_C supports USB 2.0 data as a device, CVS enumerates the PUT_C with USB 2.0 messaging
 11. CVS waits 10s
 12. CVS transitions to Disabled.
 13. CVS attaches Rd on its CCs.
 14. CVS and PUT enter attached states.
 - a. CVS negotiates a contract with the PUT_C and continues negotiations, accepting PR_Swaps and making best effort to provide the max power contract that the PUT_C offers / requests.

- b. If the PUT_C supports USB 3.2 data as a host, CVS enumerates on the PUT_C with USB 3.2 messaging
- c. If the PUT_C supports USB 2.0 data as a host, CVS enumerates on the PUT_C with USB 2.0 messaging
- 15. CVS sends a Vconn_Swap message and the CVS and PUT_C complete a Vconn_Swap.
- 16. CVS sends Discover ID SOP'
- 17. CVS verifies that it receives Discover ID SOP' Response [TD.4.11.3.V.5]
- 18. CVS waits 10s
- 19. CVS transitions to Disabled

Hub Ports Tests

TD 4.12.1 Hub Port 3.1 Test

This test has been removed.

TD 4.12.2 Hub Port Types Test

- A. Purpose:
 - 1. Verify a hub has only one UFP connector
- B. Applicability:
 - 1. This test is applicable for a PUT that is part of a hub, as indicated with VIF field Type_C_Port_On_Hub set to YES.
 - 2. For this test, the test operator cycles through each exposed USB Type-C port on the hub under test
 - 3. This test is only required to be run once per hub or compound device.
- C. Asserts
 - 1. 4.7#2,4-7
 - 2. 5.1#4
- D. Procedure:
 - 1. Unplug all hub ports
 - 2. Set numUFPs = 0
 - 3. For each Hub port in succession:
 - a. Set bUFP = false
 - b. Plug in the port.
 - c. If PUT transitions to Unattached.SRC:
 - i. CVS transitions to presenting both CC pins in vRa range
 - ii. Wait longer than max tCCDebounce
 - iii. CVS verifies:
 - 01 If VIF field Captive_Cable is set to NO or Type_C_State_Machine is SRC, PUT pin states remain unchanged. [TD.4.12.2.V.1]
 - 02 If VIF field Captive_Cable is set to YES and Type_C_State_Machine is DRP, PUT pin states remain toggling. [TD.4.12.2.V.10]
 - iv. CVS transitions to presenting both CC pins in vRd range

- v. If VIF field Captive_Cable is set to YES, continue to step 3.c.ix
- vi. Wait longer than max tCCDebounce
- vii. Verify PUT pin states remain unchanged. [TD.4.12.2.V.2]
- viii. CVS transitions to presenting one CC pin in vRa range and one CC pin in vRd range
- ix. Verify PUT transitions to Attached.SRC within tCCDebounce max + tVbusON (475ms) [TD.4.12.2.V.3]
- x. If PUT supports USB PD:
 - 01 CVS and PUT negotiate Explicit Power contract.
 - 02 Wait 3 * tAMETimeout
 - 03 CVS verifies PUT does not initiate Discover SVIDs, Discover Modes or Enter Mode requests. [TD.4.12.2.V.4]
 - 04 If PUT requests DR_Swap then numUFPs++ and bUFP = true
- d. CVS transitions to Disabled for 200ms.
- e. CVS transitions to Unattached.SRC
- f. If PUT transitions to Unattached.SNK:
 - i. Wait tDRP
 - ii. Verify PUT did not transition to Unattached.Accessory [TD.4.12.2.V.5]
 - iii. Verify PUT did not transition to Unattached.SRC [TD.4.12.2.V.6]
 - iv. CVS transitions to Attached.SRC
 - v. Verify PUT presents zSBUTermination on SBU pins (open) [TD.4.12.2.V.7]
 - vi. If PUT does not support USB PD and bUFP = false, then numUFPs++
 - vii. If PUT supports USB PD:
 - 01 CVS and PUT negotiate an Explicit Power contract
 - 02 Wait 3 * tAMETimeout
 - 03 If PUT does not request DR_Swap and bUFP = false, then numUFPs++
 - 04 Else if PUT does request DR_Swap:
 - 1. CVS completes DR_Swap with PUT.
 - 2. Wait 3 * tAMETimeout
 - 3. CVS verifies PUT does not initiate Discover SVIDs, Discover Modes or Enter Mode requests. [TD.4.12.2.V.8]
- g. Unplug Port
- h. Skip to step 1 next port until all ports are exhausted
- 4. If numUFPs == 1
 - a. CVS prompts the test operator to verify there are no USB Type-B or Micro-B ports on the product. [TD.4.12.2.V.9]
- 5. Else If numUFPs == 0:
 - a. CVS prompts the test operator to verify that either the hub is embedded or there is exactly 1 of: USB Type-B receptacle, USB Micro-B receptacle, or USB Type-A plug on the product. [TD.4.12.2.V.10]
- 6. Else if numUFP > 1, the test fails.

USB4 PD Tests

TD 4.13.1 DFP Enter_USB Test

- A. Purpose:
1. Verify a USB4 DFP completes Enter_USB flow correctly between USB Type-C, USB PD, USB4, USB 3.2, and USB 2.0 requirements
- B. Applicability:
1. This test is applicable for a PUT that is has VIF field USB4_DFP_Supported set to YES
- C. Asserts
1. 5.4.1#1-2
 2. 5.4.2#1-2
 3. 5.4.3.2#1,3
 4. 5.4.3.2.1#1-2
 5. 5.4.3.3#1-3
 6. USB PD 6.4.8#1
 7. USB PD 6.4.8#3
 8. USB PD 6.4.8#8-10
 9. USB PD 6.4.8.2#1-2
 10. USB PD 6.4.8.4#1
 11. USB PD 6.4.8.5#1
 12. USB PD 6.4.8.6#1
 13. USB PD 6.4.8.10#1
 14. USB PD 6.6.20#1
- D. Conditions
1. CVS emulates cable with no E-Marker [\[TD.4.13.1.C.1\]](#)
 2. CVS emulates passive cable with Cable VDO USB Highest Speed set to 000b [\[TD.4.13.1.C.2\]](#)
 3. CVS emulates passive cable with Cable VDO USB Highest Speed set to 001b, TBT3 Discover Mode VDO TBT_Rounded_Support set to 00b, Cable Speed set to 001b [\[TD.4.13.1.C.3\]](#)
 4. This test condition has been removed.
 5. CVS emulates passive cable with Cable VDO USB Highest Speed set to 010b, TBT3 Discover Mode VDO Active_Passive set to 1b, TBT_Rounded_Support set to 01b, Cable Speed set to 011b [\[TD.4.13.1.C.5\]](#)
 6. CVS emulates passive cable with Cable VDO USB Highest Speed set to 011b [\[TD.4.13.1.C.6\]](#)
 7. CVS emulates active cable with Cable VDO USB Highest Speed set to 000b [\[TD.4.13.1.C.7\]](#)
 8. CVS emulates active cable with Cable VDO USB Highest Speed set to 010b, Active Cable VDO2 USB4 Supported bit set to NO, TBT3 Discover Mode VDO TBT_Rounded_Support set to 00b, Cable Speed set to 011b [\[TD.4.13.1.C.8\]](#)
 9. This test condition has been removed.
 10. CVS emulates active cable with Cable VDO USB Highest Speed set to 011b [\[TD.4.13.1.C.10\]](#)
 11. This test condition has been removed.
 12. CVS emulates active cable with Cable VDO USB Highest Speed set to 011b, SOP'' Controller Present set to 1 [\[TD.4.13.1.C.12\]](#)
 13. CVS emulates a passive cable with Cable VDO USB Highest Speed set to 001b, no TBT3 Alt Mode support [\[TD.4.13.1.C.13\]](#)
 14. CVS emulates a Passive cable with Cable VDO USB Highest Speed set to 010b, TBT3 Discover Mode VDO Active_Passive set to 0b, TBT_Rounded_Support set to 00b, Cable Speed set to 011b. [\[TD.4.13.1.C.14\]](#)

15. CVS emulates a Passive cable with Cable VDO USB Highest Speed set to 010b, TBT3 Discover Mode VDO Active_Passive set to 0b, TBT_Rounded_Support set to 00b, Cable Speed set to 010b [TD.4.13.1.C.15]
16. CVS emulates an active cable with active cable VDO version = 1.2, USB Highest Speed set to 010b, TBT3 Discover Mode VDO TBT_Rounded_Support set to 01b, Cable Speed set to 011b [TD.4.13.1.C.16]
17. CVS emulates an active cable with active cable VDO version = 1.2, USB Highest Speed set to 010b, TBT3 Discover Mode VDO TBT_Rounded_Support set to 00b, Cable Speed set to 011b [TD.4.13.1.C.17]

Cable Highest Speed	Product Type	Active Cable VDO2 USB4 Supported	Cable Support TBT3 / SOP' Modal Operation	Cable TBT3 Passive /Active	Cable Support TBT3 Rounded	Cable Speed	SOP'' Controller	Test Condition #
no emarker	n/a	n/a	n/a	n/a	n/a	n/a	0	C.1
000b	passive	n/a	0	n/a	n/a	n/a	0	C.2
000b	active	No	0	n/a	n/a	n/a	0	C.7
001b	passive	n/a	0	n/a	n/a	n/a	0	C.13
001b	passive	n/a	1	passive	0	001b	0	C.3
010b	passive	n/a	1	passive	0	011b	0	C.14
010b	passive	n/a	1	passive	0	010b	0	C.15
010b	passive	n/a	1	active redriver	1	011b	0	C.5
010b	active	No	1	active retimer	0	011b	0	C.8
010b	active	n/a (VDO version 1.2)	1	active retimer	1	011b	0	C.16
010b	active	n/a (VDO version 1.2)	1	active retimer	0	011b	0	C.17
011b	passive	n/a	0	n/a	n/a	n/a	0	C.6
011b	active	Yes	0	n/a	n/a	n/a	0	C.10
011b	active	Yes	0	n/a	n/a	n/a	1	C.12

Table representation for CVS cable emulation values from Section D Conditions

E. Procedure:

1. CVS emulates a cable per Condition 1 above for the rest of the test. Unless the Condition describes otherwise, CVS responds to SOP' with Cable VDO SOP'' Controller Present set to 0.
2. CVS emulates a USB4 device for the rest of the test with Discover ID UFP VDO USB Highest Speed set to 011b (USB4 Gen3)
3. CVS transitions to Unattached.SNK
4. CVS and PUT transition through the USB Type-C State Machine to Attached.SNK and Attached.SRC.
5. CVS verifies that:

- a. If not Condition 1, the PUT transmits Discover ID to SOP'. [TD.4.13.1.V.1]
- b. If Condition 5:
 - i. The PUT transmits Discover SVIDs to SOP' [TD.4.13.1.V.30]
 - ii. CVS responds with the TBT3 SVID
 - iii. The PUT transmits Discover Modes for the TBT3 SVID to SOP' [TD.4.13.1.V.31]
 - iv. CVS responds with the TBT3 Mode defined in the Conditions table and Tests section
- c. The PUT advertises at least 7.5W in its Source Capabilities message [TD.4.13.1.V.2]
- d. If PUT transmits Discover ID to SOP, it occurs after PUT and CVS establish an Explicit Contract. [TD.4.13.1.V.3]
- e. If Condition 3, 5, 6, 10, 12, 13, 14, 15, or 16, PUT transmits Discover ID to SOP. [TD.4.13.1.V.4]
6. If Condition 1, 2, or 7, CVS verifies:
 - a. PUT either does not transmit Enter_USB or transmits Enter_USB to SOP with USB Mode set to 000b [TD.4.13.1.V.6]
 - b. PUT enumerates at USB 3.2 or USB 2.0 speed [TD.4.13.1.V.7]
7. If Condition 8 or 17, CVS verifies:
 - a. PUT either does not transmit Enter_USB or transmits Enter_USB to SOP with USB Mode set to 001b [TD.4.13.1.V.8]
 - b. PUT enumerates at USB 3.2 speeds (i.e. Gen 1 or Gen 2) [TD.4.13.1.V.9]
8. If Condition 16, CVS verifies:
 - a. PUT either does not transmit Enter_USB or transmits Enter_USB to SOP with USB Mode set to 001b or 010b [TD.4.13.1.V.32]
 - b. If the PUT did not transmit Enter_USB or transmitted Enter_USB to SOP with USB Mode set to 001, PUT enumerates at USB 3.2 Gen 2 speed or VIF field Host_Speed, whichever is lowest [TD.4.13.1.V.33]
9. If Condition 3, 5, 6, 10, 12, 13, 14, or 15:
 - a. If Condition 10 or 12:
 - i. CVS verifies PUT transmits Enter_USB to SOP' with USB Mode set to 010b [TD.4.13.1.V.10]
 - ii. CVS responds to SOP' with Accept message
 - b. If Condition 12:
 - i. CVS verifies PUT transmits Enter_USB to SOP'' with USB Mode set to 010b [TD.4.13.1.V.12]
 - ii. CVS responds to SOP'' with Accept message
 - c. CVS verifies PUT transmits Enter_USB to SOP with USB Mode set to 010b [TD.4.13.1.V.14]
 - d. CVS responds with Accept message
 - e. CVS verifies:
 - i. SBUs enter 3V USB4 signaling range [TD.4.13.1.V.15]
 - ii. PUT did not transmit DR_Swap after starting Discovery process [TD.4.13.1.V.16]
 - iii. PUT did not transmit Vconn_Swap after starting Discovery process [TD.4.13.1.V.17]
 - iv. PUT transmitted Enter_USB to SOP' first if present, then SOP'' if present, then SOP [TD.4.13.1.V.18]
10. If PUT transmitted the Enter_USB message:
 - a. CVS verifies:
 - i. The message was transmitted within tEnterUSB from the first GoodCRC response to the Source Capabilities message [TD.4.13.1.V.19]
 - ii. Bits B31, B27, B24, B12..0 are set to 0 [TD.4.13.1.V.20]

- iii. If Condition 2, 3, 6, 7, 8, 10, 12, 13, 15, or 17, the Cable Speed is set to CVS Cable VDO response or VIF field USB4_Max_Speed, whichever is lower, and Cable Type and Cable Current fields are set in accordance with the CVS Cable VDO response. [TD.4.13.1.V.21]
 - iv. If Condition 5, Cable Speed is set to 011b or VIF field USB4_Max_Speed value (whichever is lower), Cable Type is set to 10b, Cable Current set as in CVS Cable VDO [TD.4.13.1.V.28]
 - v. If Condition 14, Cable Speed is set to 011b or VIF field USB4_Max_Speed value (whichever is lower), Cable Type and Cable Current are set as in the CVS Cable VDO. [TD.4.13.1.V.29]
 - vi. If Condition 16, Cable Speed is set to 010b or 011b, Cable Type and Cable Current are set as in the CVS Cable VDO. [TD.4.13.1.V.34]
 - vii. If Condition 16 and USB Mode is set to 010b, Cable Speed is set to 011b [TD.4.13.1.V.35]
 - viii. If Condition 16 and USB Mode is set to 001b, Cable Speed is set to 010b [TD.4.13.1.V.36]
 - ix. The Host Present field is set to 1 [TD.4.13.1.V.22]
 - b. If the PUT has VIF field USB4_UFP_Supported set to YES, CVS verifies the Enter_USB message USB4 DRD field is set to 1 [TD.4.13.1.V.23]
 - c. If the VIF field Type_C_Can_Act_As_Device is set to YES and Device_Speed is USB 3.2 Gen 1x1 or above, the CVS verifies the Enter_USB USB3 DRD field is set to 1 [TD.4.13.1.V.24]
 - d. If the PUT has VIF field USB4_PCIE_Tunneling_Supported set to YES, CVS verifies the Enter_USB PCIe Support field is set to 1 [TD.4.13.1.V.25]
 - e. If the PUT has VIF field USB4_DP_Tunneling_Supported set to YES, CVS verifies the Enter_USB DP Support field is set to 1 [TD.4.13.1.V.26]
 - f. If the PUT has VIF field USB4_TBT3_Compatibility_Supported set to YES, CVS verifies the Enter_USB TBT Support field is set to 1 [TD.4.13.1.V.27]
11. CVS transitions to Disabled
 12. Wait 500ms
 13. CVS continues to step 1 using the next Condition in section D.

TD 4.13.2 UFP Enter_USB Test

- A. Purpose:
 1. Verify a UFP responds to Enter_USB flow correctly
- B. Applicability:
 1. This test is applicable for a PUT that has VIF field USB4_UFP_Supported set to YES
 2. This test is applicable for a PUT that has VIF field USB4_DFP_Supported set to YES and Type_C_Port_On_Hub set to NO
- C. Asserts
 1. 5.2.1#1
 2. 5.2.2#1-3
 3. 5.4.2#2
 4. 5.4.3.2#2
 5. USB PD 6.4.8#2
- D. Conditions
 1. CVS emulates USB4 Host connected to USB4 Gen3 capable cable [TD.4.13.2.C.1]
 2. CVS emulates USB4 Host connected to USB4 Gen2 capable cable [TD.4.13.2.C.2]
 3. CVS emulates USB4 Host connected to USB 3.2 Gen2 capable Active cable with Active Cable VDO2 field USB4 Capable set to 1b (Not Supported) [TD.4.13.2.C.3]

4. CVS emulates USB4 Host connected to USB 2.0 capable cable [TD.4.13.2.C.4]
 5. CVS emulates USB4 Host [TD.4.13.2.C.5]
 6. CVS emulates USB 3.2 Host [TD.4.13.2.C.6]
 7. CVS emulates USB 2.0 Host [TD.4.13.2.C.7]
- E. Procedure:
1. CVS emulates Host and Cable per Condition 1 for the rest of the test.
 2. If Condition 1-4 and VIF field Captive_Cable is YES, skip to step 1 with next Condition from section D
 3. If Condition 5-7 and VIF field Captive_Cable is NO, CVS also emulates a USB4 Gen3 capable cable for the rest of the test.
 4. CVS transitions to Unattached.SRC
 5. CVS and PUT transition through state machine to Attached.SRC and Attached.SNK
 6. If Condition 5 or 6 and VIF field Captive_Cable is YES:
 - a. CVS transmits Discover ID on SOP'
 - b. CVS verifies:
 - i. PUT responds on SOP' with Discover ID Response [TD.4.13.2.V.1]
 - ii. If PUT has VIF field USB4_Max_Speed set to 0, Cable VDO USB Highest Speed is set to 010b [TD.4.13.2.V.2]
 - iii. If PUT has VIF field USB4_Max_Speed set to 1, Cable VDO USB Highest Speed is set to 011b [TD.4.13.2.V.3]
 - c. CVS and PUT complete discovery process on SOP' with Discover SVIDs and Discover Modes messages
 - i. If VIF field USB4_DP_Tunneling_Supported is YES, CVS verifies that PUT response contains DP SVID, 0xFF01 [TD.4.13.2.V.4]
 - ii. If VIF field USB4_TBT3_Compatibility_Supported is YES, CVS verifies PUT response contains TBT3 SVID, 0x8087 [TD.4.13.2.V.5]
 7. CVS advertises 7.5W in its Source Capabilities
 8. CVS and PUT establish an Explicit Contract
 9. If Condition 1-6:
 - a. CVS transmits Discover ID on SOP
 - b. If PUT has VIF field Type_C_Can_Act_As_Device set to YES or Modal_Operation_Supported_SOP set to YES, CVS verifies:
 - i. PUT responds on SOP with Discover ID Response with UFP VDO [TD.4.13.2.V.6]
 - ii. If PUT has VIF field USB4_DFP_Supported set to YES, its Discover ID Response also includes DFP VDO [TD.4.13.2.V.7]
 - iii. If PUT has VIF field USB4_Max_Speed set to 0, UFP VDO USB Highest Speed is set to 010b [TD.4.13.2.V.8]
 - iv. If PUT has VIF field USB4_Max_Speed set to 1, UFP VDO USB Highest Speed is set to 011b [TD.4.13.2.V.9]
 - v. UFP VDO Device Capability Bit 0 or 1 must be set to 1 [TD.4.13.2.V.10]
 - c. If PUT has VIF field USB4_UFP_Supported set to YES, UFP VDO Device Capability Bit 3 must be set to 1 [TD.4.13.2.V.11]
 - d. If PUT has VIF field Type_C_Can_Act_As_Device set to NO and Modal_Operation_Supported_SOP set to NO, CVS verifies:
 - i. PUT responds on SOP with Discover ID Response with DFP VDO and not UFP VDO [TD.4.13.2.V.16]
 - ii. DFP VDO field Host Capability bit 2 is set to 1 [TD.4.13.2.V.17]
 - e. If Condition 1:
 - i. If PUT has VIF field USB4_Max_Speed set to 1, CVS transmits Enter_USB on SOP with USB Mode set to 010b and Cable Speed set to 011b

- ii. If PUT has VIF field USB4_Max_Speed set to 0, CVS transmits Enter_USB on SOP with USB Mode set to 010b and Cable Speed set to 010b
 - f. If Condition 2, CVS transmits Enter_USB on SOP with USB Mode set to 010b and Cable Speed set to 010b
 - g. If Condition 3 and VIF field Type_C_Can_Act_As_Device is YES, CVS transmits Enter_USB on SOP with USB Mode set to 001b and Cable Speed set to 001b
 - h. If Condition 4 and VIF field Type_C_Can_Act_As_Device is YES, CVS transmits Enter_USB on SOP with USB Mode set to 000b and Cable Speed set to 000b
 - i. If Condition 5, CVS transmits Enter_USB on SOP with USB Mode set to 010b and Cable Speed set according to response in Cable VDO
 - j. If Condition 1, 2 or 5, or (Condition 3 or 4 and VIF field Type_C_Can_Act_As_Device is YES), CVS verifies that PUT responds with Accept message [TD.4.13.2.V.12]
 - k. If Condition 3 and VIF field Type_C_Can_Act_As_Device is YES, CVS verifies that PUT applies eSS terms within 1s after receiving the Enter_USB message [TD.4.13.2.V.18]
 - l. If Condition 4 and VIF field Type_C_Can_Act_As_Device is YES, CVS verifies that PUT applies D+/D- terms within 1s after receiving the Enter_USB message [TD.4.13.2.V.19]
- 10. If Condition 6:
 - a. CVS applies DFP eSS terminations after tEnterUSB (500ms) from the first GoodCRC response to a Source Capabilities message received from the PUT
 - b. CVS transmits Warm Reset LFPS
 - c. If PUT has VIF field Device_Speed set greater than 0:
 - i. CVS verifies that UFP applies eSS terminations after 1s and before 2s from Vbus ON [TD.4.13.2.V.13]
 - ii. CVS begins device enumeration process
 - iii. If PUT has VIF field Type_C_Port_On_Hub set to NO, CVS verifies Billboard interface is exposed [TD.4.13.2.V.14]
- 11. If Condition 7 and VIF field Type_C_Can_Act_As_Device is YES:
 - a. CVS begins USB 2.0 enumeration after tUSB4Timeout
 - b. CVS verifies:
 - i. The UFP applies D+/D- terms after 1s and before 2s from Vbus ON [TD.4.13.2.V.20]
 - ii. Billboard interface is exposed [TD.4.13.2.V.15] (Note: On a hub the Billboard device is located on a non-removable downstream port)
- 12. CVS transitions to Disabled
- 13. CVS waits 500ms
- 14. CVS continues to step 2 with CVS emulating the next Conditions from Section D

TD 4.13.3 DFP Data_Reset Test

- A. Purpose:
 - 1. Verify a DFP port responds to the Data_Reset command as expected
- B. Applicability:
 - 1. This test is applicable for a PUT that has USB4_DFP_Supported set to YES
- C. Asserts
 - 1. 5.4.4.2#1,3

2. USB PD 6.3.14#1-10
3. USB PD 6.3.14#15-18
4. USB PD 6.3.15.1#1
5. USB PD 6.4.8#3
6. USB PD 6.6.10.1#1
7. USB PD 6.6.10.2#2
8. USB PD 6.6.10.3#1,2
9. USB PD 6.6.20#1
10. USB PD 7.1.15.1#3,4
11. USB PD 7.1.15.2#2-4

D. Conditions

1. CVS emulates USB4 Active Cable and USB4 device [TD.4.13.3.C.1]
2. CVS emulates USB4 Active Cable and USB 3.2 device [TD.4.13.3.C.2]
3. CVS emulates USB4 Active Cable and USB 2.0 device [TD.4.13.3.C.3]
4. CVS emulates USB4 Passive Cable and USB4 device [TD.4.13.3.C.4]
5. CVS emulates USB4 Passive Cable and USB 3.2 device [TD.4.13.3.C.5]
6. CVS emulates USB4 Passive Cable and USB 2.0 device [TD.4.13.3.C.6]

E. Procedure:

1. CVS emulates a USB Device and Cable as described in Condition 1
2. CVS transitions to Unattached.SNK
3. Unless specified in a test step, CVS does not initiate Vconn_Swap message, and Rejects any Vconn_Swap messages it receives
4. CVS and PUT complete USB4 Discovery process
5. If Condition 1 CVS verifies that PUT sends Enter_USB to SOP' with USB Mode field set to 010b [TD.4.13.3.V.1]
6. If Condition 1 or 4:
 - a. CVS verifies that PUT sends Enter_USB to SOP with USB Mode field set to 010b [TD.4.13.3.V.2]
 - b. CVS verifies PUT starts signaling on SBUs (SBTX) [TD.4.13.3.V.3]
7. If Condition 2 or 5:
 - a. If PUT sends Enter_USB to SOP' and or SOP, CVS verifies USB Mode field is set to 001b [TD.4.13.3.V.4]
 - b. CVS applies eSS terminations and starts USB 3.2 signaling
8. If Condition 3 or 6:
 - a. If PUT sends Enter_USB to SOP' and or SOP, CVS verifies USB Mode field is set to 000b [TD.4.13.3.V.5]
 - b. CVS applies D+ terminations and starts USB 2.0 signaling
9. CVS waits 50ms
10. CVS transmits Data_Reset message
11. CVS verifies:
 - a. The PUT responds with Accept message [TD.4.13.3.V.6]
 - b. If Condition 1 or 4, PUT drives SBTX low after receiving GoodCRC [TD.4.13.3.V.7]
 - c. If Condition 1, 2, 4, or 5, PUT drives RX terminations low after receiving GoodCRC [TD.4.13.3.V.8]
 - d. If Condition 3 or 6, PUT disconnects the port's D+/D- signals after receiving the GoodCRC [TD.4.13.3.V.9]
 - e. Vconn voltage is below vRaReconnect within tVconnZero after receiving GoodCRC [TD.4.13.3.V.10]
 - f. Vconn voltage remains below vRaReconnect for tVconnReapplied [TD.4.13.3.V.11]
 - g. Vconn is within vVconnValid within tVconnValid [TD.4.13.3.V.12]
 - h. Vconn is within vVconnValid within tDataReset after receiving GoodCRC [TD.4.13.3.V.13]

- i. If Condition 1, 2, 4, or 5, PUT applies RX terminations after tDataReset [TD.4.13.3.V.14]
 - j. If Condition 3 or 6, PUT applies D+/D- after tDataReset [TD.4.13.3.V.15]
 - k. The PUT sends Data_Reset_Complete Message [TD.4.13.3.V.16]
 - l. The PUT did not send Vconn_Swap after it responded with Accept message [TD.4.13.3.V.17]
 - m. The PUT enters USB4 Discovery flow (by sending Discover ID to SOP' and then to SOP). [TD.4.13.3.V.18]
 - n. The PUT maintained Vbus according to negotiated Power Contract after it responded with Accept message [TD.4.13.3.V.36]
12. CVS and PUT complete USB4 Discovery process
 13. If Condition 1 CVS verifies that PUT sends Enter_USB to SOP' with USB Mode field set to 010b [TD.4.13.3.V.19]
 14. If Condition 1 or 4:
 - a. CVS verifies that PUT sends Enter_USB to SOP with USB Mode field set to 010b [TD.4.13.3.V.20]
 - b. CVS verifies PUT starts signaling on SBUs (SBTX) [TD.4.13.3.V.21]
 15. If Condition 2 or 5:
 - a. If PUT sends Enter_USB to SOP' and or SOP, CVS verifies USB Mode field is set to 001b [TD.4.13.3.V.22]
 - b. CVS applies eSS terminations and starts USB 3.2 signaling
 16. If Condition 3 or 6:
 - a. If PUT sends Enter_USB to SOP' and or SOP, CVS verifies USB Mode field is set to 000b [TD.4.13.3.V.23]
 - b. CVS applies D+ terminations and starts USB 2.0 signaling
 17. If PUT sends Enter_USB to SOP, CVS verifies it is sent within tEnterUSB after the GoodCRC was received in responds to the Data_Reset_Complete message [TD.4.13.3.V.37]
 18. CVS and PUT perform Vconn_Swap (CVS will accept or initiate for 5 attempts)
 19. If PUT does not initiate Vconn_Swap and responds to CVS with Reject, CVS continues to step 1 with next Condition in Section D
 20. Wait 50ms
 21. CVS transmits Data_Reset message
 22. CVS verifies:
 - a. The PUT responds with Accept message [TD.4.13.3.V.24]
 - b. If Condition 1 or 4, PUT drives SBTX low after receiving GoodCRC [TD.4.13.3.V.25]
 - c. If Condition 1, 2, 4, or 5, PUT drives RX terminations low after receiving GoodCRC [TD.4.13.3.V.26]
 - d. If Condition 3 or 6, PUT disconnects the port's D+/D- signals after receiving the GoodCRC [TD.4.13.3.V.27]
 23. If Condition 1:
 - a. CVS waits tVconnZero
 - b. CVS does not transmit PS_RDY
 - c. CVS verifies that after DataResetFailTimer expires, PUT enters ErrorRecovery [TD.4.13.3.V.35]
 - d. CVS continues to step 1 with next Condition in Section D
 24. CVS transmits PS_RDY
 25. CVS verifies:
 - a. Vconn voltage remains below vRaReconnect for tVconnReapplied [TD.4.13.3.V.28]
 - b. Vconn is within vVconnValid within tVconnValid [TD.4.13.3.V.29]
 - c. Vconn is within vVconnValid within tDataReset after receiving GoodCRC [TD.4.13.3.V.30]

- d. If Condition 1, 2, 4, or 5, PUT applies RX terminations after tDataReset [TD.4.13.3.V.31]
 - e. If Condition 3 or 6, PUT applies D+/D- after tDataReset [TD.4.13.3.V.32]
 - f. The PUT sends Data_Reset_Complete Message [TD.4.13.3.V.33]
 - g. The PUT enters USB4 Discovery flow:
 - i. The PUT sends Discover ID to SOP. [TD.4.13.3.V.34]
 - ii. If condition 1, the PUT sends Discover ID to SOP'. [TD.4.13.3.V.38]
26. CVS and PUT complete USB4 Discovery process
27. CVS continues to step 1 with next Condition in Section D

TD 4.13.4 UFP Data_Reset Test

- A. Purpose:
 - 1. Verify a UFP port responds to the Data_Reset command as expected
- B. Applicability:
 - 1. This test is applicable for a PUT that has VIF field USB4_UFP_Supported set to YES
 - 2. This test is applicable for a PUT that has VIF field USB4_DFP_Supported set to YES and Type_C_Port_On_Hub set to NO
- C. Asserts
 - 1. 5.4.4.2#1,2
 - 2. USB PD 6.3.14#1-6,11-12
 - 3. USB PD 7.1.15.1#1,2
- D. Conditions
 - 1. CVS emulates USB4 Host connected to USB4 Active cable [TD.4.13.4.C.1]
 - 2. CVS emulates USB4 Host connected to USB4 Passive cable [TD.4.13.4.C.2]
 - 3. CVS emulates USB 3.2 Host connected to USB4 Active cable [TD.4.13.4.C.3]
 - 4. CVS emulates USB 2.0 Host connected to USB4 Active cable [TD.4.13.4.C.4]
 - 5. CVS emulates USB4 Host connected to USB4 Passive cable before the Data_Reset, and a USB 2.0 Host connected to USB4 Passive cable after the Data_Reset [TD.4.13.4.C.5]
- E. Procedure:
 - 1. CVS emulates a USB Host and Cable as described in Condition 1
 - 2. CVS transitions to Unattached.SRC
 - 3. Unless specified in a test step, CVS does not initiate Vconn_Swap message, and Rejects any Vconn_Swap messages it receives
 - 4. CVS and PUT complete USB4 Discovery process
 - 5. CVS starts USB signaling as negotiated on D+/D-, eSS, and SBTX
 - 6. CVS enumerates the PUT
 - 7. CVS waits 50ms
 - 8. CVS transmits Data_Reset message
 - 9. CVS verifies PUT sends Accept message [TD.4.13.4.V.1]
 - 10. CVS disconnects D+/D- terminations
 - 11. CVS removes RX terminations if they were attached for USB 3.2 or USB4 signaling
 - 12. CVS drives SBTX to logic low if they were in use for USB4 signaling
 - 13. CVS waits tDataReset
 - 14. CVS reapplies D+/D- and RX terminations if they were removed before tDataReset
 - 15. CVS transmits Data_Reset_Complete message
 - 16. CVS verifies PUT did not send Vconn_Swap message since it sent Accept message [TD.4.13.4.V.2]
 - 17. If Condition 1-4, CVS and PUT complete USB4 Discovery process
 - 18. If Condition 5, CVS does not initiate the USB4 Discovery process or send Enter_USB message.
 - 19. If (Condition 3 and VIF field Type_C_Port_On_Hub is NO) or Condition 4 or 5:

- a. CVS sends GetDescriptors to the PUT every 50ms starting immediately after the last test step.
 - b. If (Condition 3 and VIF field Type_C_Port_On_Hub is NO) or Condition 4:
 - i. CVS verifies PUT exposes USB Billboard Device Class Interface in Descriptor within 1s of CVS transmitting the Enter_USB message. [TD.4.13.4.V.8] Note: If VIF field Type_C_Port_On_Hub is YES, CVS looks for the exposed USB Billboard Device Class Interface in the descriptors of a downstream port on the hub product with a relative address from the hub UFP as defined in the VIF field Hub_Billboard_DSPort_Num. In this case, CVS verifies the first status change indicator for the Billboard Device is received within 1s of CVS transmitting the Enter_USB message.
 - ii. If the PUT field Type_C_Port_on_Hub is NO, CVS verifies that the host is notified about the updated descriptors through PUT terminations. [TD.4.13.4.V.9] Note: Non-hub UFPs may hold off the enumeration process until the Billboard is present or reset to indicate an update has occurred. UFPs may not respond to GetDescriptors continuously and update descriptors along the way – they must provoke a new GetDescriptor from a host using device terminations.
 - c. If Condition 5:
 - i. CVS verifies PUT exposes USB Billboard Device Class Interface in Descriptor after tUSB4Timeout and before tUSB4Timeout + 500ms. [TD.4.13.4.V.10] Note: If VIF field Type_C_Port_On_Hub is YES, CVS looks for the exposed USB Billboard Device Class Interface in the descriptors of a downstream port on the hub product with a relative address from the hub UFP as defined in the VIF field Hub_Billboard_DSPort_Num. In this case, CVS verifies the first status change indicator for the Billboard Device is received after tUSB4Timeout and before tUSB4Timeout + 500ms.
 - ii. If the PUT field Type_C_Port_on_Hub is NO, CVS verifies that the host is notified about the updated descriptors through PUT terminations. [TD.4.13.4.V.11] Note: Non-hub UFPs may hold off the enumeration process until tUSB4Timeout expires or enumerate before and then reset after tUSB4Timeout. UFPs may not respond to GetDescriptors continuously and update descriptors along the way – they must provoke a new GetDescriptor from a host using device terminations.
20. If VIF field VCONN_Swap_To_On_Supported is NO, continue to step 34.
 21. CVS starts USB signaling as negotiated on D+/D-, eSS, and SBTX
 22. CVS and PUT complete Vconn_Swap (CVS will accept or initiate for 5 attempts)
 23. Wait 50ms
 24. CVS transmits Data_Reset message
 25. CVS verifies PUT sends Accept message [TD.4.13.4.V.3]
 26. CVS disconnects D+/D- terminations
 27. CVS removes RX terminations if they were attached for USB 3.2 or USB4 signaling
 28. CVS drives SBTX to logic low if they were in use for USB4 signaling
 29. CVS verifies:
 - a. Vconn drops to vRaReconnect within tVconnZero of CVS transmitting GoodCRC [TD.4.13.4.V.4]
 - b. PUT sends PS_RDY before tVconnSourceDischarge min timeout of transmitting GoodCRC [TD.4.13.4.V.5]
 30. CVS waits tVconnReapplied + tVconnValid max
 31. CVS reapplies D+/D- and RX terminations if they were removed before tDataReset
 32. CVS transmits Data_Reset_Complete message
 33. CVS verifies:

- a. PUT did not send Vconn_Swap message since it sent Accept message [TD.4.13.4.V.6]
 - b. PUT did not source Vconn since Vconn dropped to vRaReconnect (verification step V.4) [TD.4.13.4.V.7]
34. CVS and PUT complete USB4 Discovery process
35. If the next Condition from Section D is Condition 3:
 - a. If the VIF field Type_C_Can_Act_As_Device is set to NO, the test ends.
 - b. If the VIF field Device_Speed is not set to USB 3.2 Gen 1x1 or higher, continue to step 2 with CVS emulating a USB Host and Cable according to Condition 4
36. CVS continues to step 2 with CVS emulating a USB Host and Cable according to the next Condition from Section D

TD 4.13.5 Cable EnterUSB and Data Reset Test

- A. Purpose:
 1. Verify a cable plug responds to PD Discover Identity message and EnterUSB message as expected
 2. Verify a cable reapplies Ra within PD Data Reset message timing constraints
- B. Applicability:
 1. This test is applicable for a PUT that has VIF field VIF_Product_Type set to 1 (Cable) and USB4_Supported set to YES
 2. This test is applicable only if the PUT VIF indicates an End Product
- C. Asserts
 1. 5.4.4.2#1,2
 2. USB PD 6.3.14#1-6,11-12
 3. USB PD 7.1.15.1#1,2
- D. Conditions
 1. CVS1 is referred to as CVS, CVS2 remains in Disabled [TD.4.13.5.C.1]
 2. CVS2 is referred to as CVS, CVS1 remains in Disabled [TD.4.13.5.C.2]
- E. Procedure:
 1. CVS verifies CPUT Vconn pin is terminated with Ra [TD.4.13.5.V.1]
 2. CVS presents Rp and Rd present on CC
 3. After tCCDebounce max CVS applies Vbus and Vconn
 4. CVS transmits Discover ID to SOP'
 5. CVS verifies CPUT responds with:
 - a. Cable VDO "USB Highest Speed" field set to 10b (USB4 20gbps) or 11b (USB4 40gbps) [TD.4.13.5.V.2]
 - b. Cable VDO "Connector Type" field set to 10b [TD.4.13.5.V.3]
 - c. For a CPUT with VIF field Product_Type set to Passive cable:
 - i. ID Header VDO Product Type field is set to 11b [TD.4.13.5.V.4]
 - ii. Cable VDO Cable Termination Type field is set to 00b or 01b [TD.4.13.5.V.5]
 - d. For a CPUT with VIF field Product_Type set to Active cable:
 - i. ID Header VDO Product Type field is set to 100b [TD.4.13.5.V.6]
 - ii. Cable VDO Cable Termination Type field is set to 10b or 11b [TD.4.13.5.V.7]
 6. CVS transmits EnterUSB on SOP'
 - a. USB Mode set to 010b
 - b. USB4 DRD set to 1
 - c. USB3 DRD set to 1
 - d. Cable Speed set to match CPUT Cable VDO USB Highest Speed
 - e. Cable Type set to match CPUT ID Header VDO Product Type

- f. Cable Current set to match CPUT Cable VDO Vbus Current Handling Capability
7. If VIF field Product_Type is set to 4 (Active Cable), then CVS verifies CPUT responds with Accept message [TD.4.13.5.V.8]
8. Repeat step 6 and 7 for SOP” if present
9. CVS waits 150ms
10. CVS:
 - a. Removes Vconn and discharges to vRaReconnect in less than 5ms
Note: faster Vconn discharge utilizes min range for tVconnZero and produces min tVconnReapplied
 - b. Starts tDataReset timer
11. CVS verifies CPUT applies Ra before tVconnReapplied min [TD.4.13.5.V.9]
12. CVS applies Vconn at tVconnReapplied max
13. CVS waits for tDataReset to elapse.
14. CVS completes steps 5-10.
15. CVS transitions to disabled
16. Continue to step 1 following the next Condition in section D

TD 4.13.6 Emarker Silicon EnterUSB and Data Reset Test

Note: This test, performed on a USB4 capable silicon Emarker only, employs a test setup with just one CVS emulating source and sink. This is an exception to the usual CPUT tests that are setup with a CVS tester connected at either side of the cable.

- A. Purpose:
 1. Verify a silicon emarker responds to PD Discover Identity message and EnterUSB message as expected
 2. Verify the USB Type-C plug reapplies Ra within PD Data Reset message timing constraints
- B. Applicability:
 1. This test is applicable for a PUT that has VIF field VIF_Product_Type set to 1 (Cable) and USB4_Supported set to YES
 2. This test is applicable only if the PUT VIF indicates the product cert is PD Silicon
- C. Asserts
 1. 5.4.4.2#1,2
 2. USB PD 6.3.14#1-6,11-12
 3. USB PD 7.1.15.1#1,2
- D. Procedure:
 1. CVS verifies CPUT Vconn pin is terminated with Ra [TD.4.13.6.V.1]
 2. CVS presents Rp and Rd present on CC
 3. After tCCDebounce max CVS applies Vbus and Vconn
 4. CVS transmits Discover ID to SOP’
 5. CVS verifies CPUT responds with:
 - a. Cable VDO “USB Highest Speed” field set to 10b (USB4 20gbps) or 11b (USB4 40gbps) [TD.4.13.6.V.2]
 - b. Cable VDO “Connector Type” field set to 10b [TD.4.13.6.V.3]
 - c. For a CPUT with VIF field Product_Type set to Passive cable:
 - i. ID Header VDO Product Type field is set to 11b [TD.4.13.6.V.4]
 - ii. Cable VDO Cable Termination Type field is set to 00b or 01b [TD.4.13.6.V.5]
 - d. For a CPUT with VIF field Product_Type set to Active cable:
 - i. ID Header VDO Product Type field is set to 100b [TD.4.13.6.V.6]

- ii. Cable VDO Cable Termination Type field is set to 10b or 11b [TD.4.13.6.V.7]
- 6. CVS transmits EnterUSB on SOP'
 - a. USB Mode set to 010b
 - b. USB4 DRD set to 1
 - c. USB3 DRD set to 1
 - d. Cable Speed set to match CPUT Cable VDO USB Highest Speed
 - e. Cable Type set to match CPUT ID Header VDO Product Type
 - f. Cable Current set to match CPUT Cable VDO Vbus Current Handling Capability
- 7. If VIF field Product_Type is set to 4 (Active Cable), then CVS verifies CPUT responds with Accept message [TD.4.13.6.V.8]
- 8. Repeat step 6 and 7 for SOP" if present
- 9. CVS waits 150ms
- 10. CVS:
 - a. Removes Vconn and discharges to vRaReconnect in less than 5ms
Note: faster Vconn discharge utilizes min range for tVconnZero and produces min tVconnReapplied
 - b. Starts tDataReset timer
- 11. CVS verifies CPUT applies Ra before tVconnReapplied min [TD.4.13.6.V.9]
- 12. CVS applies Vconn at tVconnReapplied max
- 13. CVS waits for tDataReset to elapse.
- 14. CVS completes steps 5-10.
- 15. CVS transitions to disabled

Cable Tests

See the CPUT Tests section to read about CVS test setup, expectations and procedures during CPUT tests.

TD 4.14.1 Cable Vconn Swap Test

- A. Purpose:
 - 1. Check CPUT applies Ra, discharges Vconn, and is capable of communicating at its highest USB speed
- B. Applicability:
 - 1. This test is applicable for all CPUTs
- C. Asserts
 - 1. 4.4.3#6-8
 - 2. 4.5.2.4.1.1#1
 - 3. 4.5.2.4.1.2#1
 - 4. 4.5.2.4.2#1
 - 5. 4.5.2.4.2.1#2
 - 6. 4.5.2.4.2.2#1
 - 7. 4.5.2.5.1.1#1
 - 8. 4.5.2.5.2.1#2,3
 - 9. 4.5.2.5.2.2#1
 - 10. 4.9#4,7
 - 11. 4.9.2#1
 - 12. 6#1,2,4
 - 13. 6.2#2,3
 - 14. 6.2.1#1,2
 - 15. 6.2.1.1#1,2

16. 6.2.1.3#1
17. 6.4.4#4-6,8
18. 6.6.4#1
19. 6.6.4.2#2-4,6,7
20. 6.6.4.3#1

D. Conditions:

1. CVS1 is CVSh / Vconn Source 3V, CVS2 is CVSD / Vconn Source 3V
[TD.4.14.1.C.1]
2. CVS2 is CVSh / Vconn Source 3V, CVS1 is CVSD / Vconn Source 5.5V
[TD.4.14.1.C.2]
3. CVS1 is CVSh / Vconn Source 5.5V, CVS2 is CVSD / Vconn Source 3V
[TD.4.14.1.C.3]
4. CVS2 is CVSh / Vconn Source 5.5V, CVS1 is CVSD / Vconn Source 5.5V
[TD.4.14.1.C.4]

E. Procedure:

1. CVSh and CVSD transition to Unattached.SRC and Unattached.SNK
2. CVS starts 1s timer
3. CVS verifies:
 - a. vRa is present on first CVSh far-end detect [TD.4.14.1.V.1]
 - b. If VIF field Product_Type is 4 (Active Cable), CPUT presents Zrx-high-imp-dc-pos [TD.4.14.1.V.2]
4. After 1s timer finishes, CVS transitions to Attached states, intending to start PD messaging and USB data signaling at the highest available speed. Note: This step is used in other TD 4.14.x tests. In those cases test conditions and steps explicitly stating data speed takes precedence over “highest data speed”.
5. CVS verifies:
 - a. CPUT responds to Discover ID on SOP’ within tVconnStable [TD.4.14.1.V.4]
 - b. CVSh and CVSD are communicating at the highest USB speed that the cable supports as indicated in VIF field Cable_USB_Highest_Speed throughout the test until CVSD is removed. [TD.4.14.1.V.5]
 - c. If VIF field Product_Type is 4 (Active Cable), CPUT responds to Get_Status on SOP’ [TD.4.14.1.V.6]
6. If VIF field Cable_SOP_PP_Controller is YES or Cable_Termination_Type is set to 3, CVS verifies CVSh sends and CPUT responds to a Get_Status message over SOP’ within tVconnStable [TD.4.14.1.V.7]
7. If VIF field Product_Type is 3 (Passive Cable), CVS verifies the CPUT draws no more than 20mW. Note: For the first 500ms after Vconn valid, CPUT is allowed to draw up to 75mW [TD.4.14.1.V.8]
8. If VIF field Product_Type is 4 (Active Cable), CVS verifies:
 - a. If the current test condition includes USB 3.2 data signaling, CPUT forwards far-end low-impedance receiver terminations through the cable within tFWD_RX.DETECT [TD.4.14.1.V.9]
 - b. For the duration of the test, USB RX/TX delay meets 300ns, and CVS produces a warning to indicate when delay > 125ns when signaling in USB 3.2 Gen 1 and when delay > 305ns when in USB 3.2 Gen 2. [TD.4.14.1.V.10]
 - c. During Polling.LFPS, Training states, U0, and Recovery States, CPUT draws no more than 1W in single lane mode, 1.5W in dual-lane mode [TD.4.14.1.V.11]
 - d. VIF field Cable_USB_Highest_Speed is set to 2 (USB 3.2 / USB4 Gen 2) or higher [TD.4.14.1.V.12]
9. CVSh and CVSD complete a Vconn_Swap
10. CVS verifies:
 - a. Vconn is discharged to vVconnDischarge within tVconnDischarge [TD.4.14.1.V.13]

- b. CVSh detects vRa within tRaReconnect after vVconnDisconnect min [TD.4.14.1.V.14]
 - c. USB data signaling is continuous throughout the Vconn swap [TD.4.14.1.V.15]
11. CVSD sends Soft_Reset on SOP' and SOP''
12. CVS verifies CVSh sends and CPUT responds to a Discover ID message over SOP' within tVconnStable [TD.4.14.1.V.16]
13. If VIF field Cable_SOP_PP_Controller is YES or Cable_Termination_Type is set to 3, CVS verifies that CVSh sends and CPUT responds to a Get_Status message over SOP'' within tVconnStable [TD.4.14.1.V.17]
14. CVSD transitions to Disabled, CVSh transitions to Unattached.SRC
15. The CVS that was sourcing Vconn verifies:
 - a. Vconn is discharged to vVconnDischarge within tVconnDischarge [TD.4.14.1.V.18]
 - b. CVS detects vRa within tRaReconnect after vVconnDisconnect min [TD.4.14.1.V.19]
 - c. USB data signaling states and transitions were as expected for the duration of the test until CVSD transitioned to Disabled [TD.4.14.1.V.20]
16. CVS continues to step 1 using the next Condition in section D.

TD 4.14.2 Cable Reset Test

- A. Purpose:
 1. Check CPUT implements the Type-C cable state machine
- B. Applicability:
 1. This test is applicable for all CPUTs
- C. Asserts
 1. 4.5.2.4.2.2#2
- D. Power State:
 1. CVS1 is CVSh, CVS2 is CVSD, Vconn Source 3V
 2. CVS2 is CVSh, CVS1 is CVSD, Vconn Source 3V
 3. CVS1 is CVSh, CVS2 is CVSD, Vconn Source 5.5V
 4. CVS2 is CVSh, CVS1 is CVSD, Vconn Source 5.5V
- E. Speed State:
 1. CVSh and CVSD communicate using USB 2.0
 2. CVSh and CVSD communicate using USB 3.2 Gen 1x1
 3. CVSh and CVSD communicate using USB 3.2 Gen 2x1
 4. CVSh and CVSD communicate using USB4 Gen 3
- F. Conditions:
 1. Power State 1, Speed State 1 [TD.4.14.2.C.1]
 2. Power State 2, Speed State 1 [TD.4.14.2.C.2]
 3. Power State 3, Speed State 1 [TD.4.14.2.C.3]
 4. Power State 4, Speed State 1 [TD.4.14.2.C.4]
 5. Power State 1, Speed State 2 [TD.4.14.2.C.5]
 6. Power State 2, Speed State 2 [TD.4.14.2.C.6]
 7. Power State 3, Speed State 2 [TD.4.14.2.C.7]
 8. Power State 4, Speed State 2 [TD.4.14.2.C.8]
 9. Power State 1, Speed State 3 [TD.4.14.2.C.9]
 10. Power State 2, Speed State 3 [TD.4.14.2.C.10]
 11. Power State 3, Speed State 3 [TD.4.14.2.C.11]
 12. Power State 4, Speed State 3 [TD.4.14.2.C.12]

13. Power State 1, Speed State 4 [TD.4.14.2.C.13]
14. Power State 2, Speed State 4 [TD.4.14.2.C.14]
15. Power State 3, Speed State 4 [TD.4.14.2.C.15]
16. Power State 4, Speed State 4 [TD.4.14.2.C.16]

G. Procedure:

1. Test sets CVSh and CVSd according to Section F Condition 1 above.
2. CVS completes TD 4.14.1 steps 1-8
3. CVSh sends PD Hard Reset
4. CVS verifies:
 - a. If VIF field Product Type is 4 (Active Cable), CVSh and CVSd detect Zrx-high-imp-dc-pos on far-end terminations [TD.4.14.2.V.1]
 - b. CPUT responds to Discover ID over SOP' within tVconnStable [TD.4.14.2.V.2]
 - c. If VIF field Cable_SOP_PP_Controller is YES or Cable_Termination_Type is 3, CPUT responds to Get Status over SOP'' within tVconnStable [TD.4.14.2.V.3]
5. CVS completes TD 4.14.1 steps 14-15
6. CVS completes TD 4.14.1 steps 1-8
7. CVS sends PD Cable Reset
8. CVS verifies:
 - a. If VIF field Product Type is 4 (Active Cable), CVSh and CVSd detect Zrx-high-imp-dc-pos on far-end terminations [TD.4.14.2.V.4]
 - b. CPUT responds to Discover ID over SOP' within tVconnStable [TD.4.14.2.V.5]
 - c. If VIF field Cable_SOP_PP_Controller is YES or Cable_Termination_Type is 3, CPUT responds to Get State over SOP'' within tVconnStable [TD.4.14.2.V.6]
9. CVS completes TD 4.14.1 steps 14-15
10. If VIF field Cable_USB_Highest_Speed and Active_Cable_USB_Lanes indicate support for the Speed State in the next Section F Condition above, CVS continues to step 2 using the next Condition in section F.

TD 4.14.3 Cable Alternate Mode Test

A. Purpose:

1. Check CPUT implements the Type-C cable state machine

B. Applicability:

1. This test is applicable for CPUTs where VIF field Modal_Operation_Supported is YES

C. Asserts

1. 6.7.1#1
2. 6.7.2#1
3. 6.7.3#1

D. Conditions:

1. CVS1 is CVSh, CVS2 is CVSd, Vconn Source 3V [TD.4.14.3.C.1]
2. CVS2 is CVSh, CVS1 is CVSd, Vconn Source 3V [TD.4.14.3.C.2]
3. CVS1 is CVSh, CVS2 is CVSd, Vconn Source 5.5V [TD.4.14.3.C.3]
4. CVS2 is CVSh, CVS1 is CVSd, Vconn Source 5.5V [TD.4.14.3.C.4]

E. Procedure:

1. Test sets CVSh and CVSd according to Section D Condition 1 above.
2. CVS uses the first SVID/Mode combination supported as indicated in the VIF
3. CVS completes TD 4.14.1 steps 1-8
4. CVSh sends Discover ID over SOP''

5. CVS verifies CPUT does not respond [TD.4.14.3.V.1]
6. CVSh sends Enter_Mode on SOP'
7. CVS verifies CPUT responds with ACK [TD.4.14.3.V.2]
8. If VIF field Cable_SOP_PP_Controller is YES:
 - a. CVSh sends Enter_Mode on SOP''
 - b. CVS verifies CPUT responds with ACK [TD.4.14.3.V.3]
9. CVSh sends Exit_Mode on SOP'
10. CVS verifies CPUT responds with ACK [TD.4.14.3.V.4]
11. If VIF field Cable_SOP_PP_Controller is YES:
 - a. CVSh sends Exit_Mode on SOP''
 - b. CVS verifies CPUT responds with ACK [TD.4.14.3.V.5]
12. CVS completes TD 4.14.1 steps 14-15
13. CVS continues to step 3 using the next SVID/Mode combination supported as indicated in the VIF. When all SVID/Mode combinations are exhausted, continue to step 13
14. CVS continues to step 2 using the next Condition in section D.

TD 4.14.4 Cable USB 3.2 Test

- A. Purpose:
 1. Check CPUT implements the Type-C cable state machine
- B. Applicability:
 1. This test is applicable for CPUTs where VIF field Product_Type is 4 (Active Cable)
- C. Asserts
 1. 4.6.1.2#2
 2. 6.4.4#3
 3. 6.6.4.2#5
 4. 6.6.4.4#1
 5. 6.6.4.5#1
- D. Power State:
 1. CVS1 is CVSh, CVS2 is CVSd, Vconn Source 3V
 2. CVS2 is CVSh, CVS1 is CVSd, Vconn Source 3V
 3. CVS1 is CVSh, CVS2 is CVSd, Vconn Source 5.5V
 4. CVS2 is CVSh, CVS1 is CVSd, Vconn Source 5.5V
- E. Speed State:
 1. CVSh and CVSd communicate using USB 3.2 Gen 1x1
 2. CVSh and CVSd communicate using USB 3.2 Gen 2x1
 3. CVSh and CVSd communicate using USB 3.2 Gen 1x2
 4. CVSh and CVSd communicate using USB 3.2 Gen 2x2
- F. Conditions:
 1. Power State 1, Speed State 1 [TD.4.14.4.C.1]
 2. Power State 2, Speed State 1 [TD.4.14.4.C.2]
 3. Power State 3, Speed State 1 [TD.4.14.4.C.3]
 4. Power State 4, Speed State 1 [TD.4.14.4.C.4]
 5. Power State 1, Speed State 2 [TD.4.14.4.C.5]
 6. Power State 2, Speed State 2 [TD.4.14.4.C.6]
 7. Power State 3, Speed State 2 [TD.4.14.4.C.7]
 8. Power State 4, Speed State 2 [TD.4.14.4.C.8]
 9. Power State 1, Speed State 3 [TD.4.14.4.C.9]

10. Power State 2, Speed State 3 [TD.4.14.4.C.10]
11. Power State 3, Speed State 3 [TD.4.14.4.C.11]
12. Power State 4, Speed State 3 [TD.4.14.4.C.12]
13. Power State 1, Speed State 4 [TD.4.14.4.C.13]
14. Power State 2, Speed State 4 [TD.4.14.4.C.14]
15. Power State 3, Speed State 4 [TD.4.14.4.C.15]
16. Power State 4, Speed State 4 [TD.4.14.4.C.16]

G. Procedure:

1. Test sets CVSh and CVSd according to Section F Condition 1 above.
2. CVS completes TD 4.14.1 steps 1-8
3. CVSh and CVSd complete an LGO_U1 transaction to enter U1.
4. CVSd transmits Ping.LFPS with min tBurst (40ns) every min tRepeat (160ms) in U1.
This step continues for 550ms
5. CVS verifies:
 - a. CPUT draws power \leq its U0 power consumption while in U1 [TD.4.14.4.V.1]
 - b. CPUT forwards the Ping.LFPSs across the cable [TD.4.14.4.V.2]
6. CVSd initiates a U1 Exit LFPS.
7. CVS verifies it is forwarded across the cable within 500 ns [TD.4.14.4.V.3]
8. CVSh and CVSd complete a U1 exit to U0 and waits 50ms
9. CVSh and CVSd complete an LGO_U1 transaction to enter U1.
10. CVSd transmits Ping.LFPS with max tBurst (200ns SS, 160ns SSP) every max tRepeat (240ms) in U1. This step continues for 550ms
11. CVS verifies:
 - a. CPUT draws power \leq its U0 power consumption while in U1 [TD.4.14.4.V.4]
 - b. CPUT forwards the Ping.LFPSs across the cable [TD.4.14.4.V.5]
12. CVSd initiates a U1 Exit LFPS.
13. CVS verifies it is forwarded across the cable within 500 ns [TD.4.14.4.V.6]
14. CVSh and CVSd complete a U1 exit to U0 and waits 50ms
15. CVSh and CVSd complete an LGO_U1 transaction to enter U1.
16. CVSd transmits U1 exit LFPS 3us after transmitting the last bit of the LAU.
17. CVS verifies CPUT forwards the U1 Exit LFPS across the cable within 500 ns [TD.4.14.4.V.7]
18. CVSh and CVSd complete a U1 exit to U0 and waits 50ms
19. CVSh and CVSd complete and LGO_U2 transaction to enter U2.
20. CVS waits 550ms
21. CVS verifies CPUT draws power \leq its U1 power consumption while in U2 [TD.4.14.4.V.8]
22. CVSd initiates a U2 Exit LFPS
23. CVS verifies it is forwarded across the cable within 2ms [TD.4.14.4.V.10]
24. CVSh and CVSd complete a U2 exit to U0 and waits 50ms
25. CVSh and CVSd complete an LGO_U3 transaction to enter U3
26. CVS verifies CPUT draws power \leq 20mW while in U3. [TD.4.14.4.V.11]
27. CVSd initiates a U3 Exit LFPS
28. CVS verifies it is forwarded across the cable within 100us [TD.4.14.4.V.12]
29. CVS verifies it is forwarded back from CVSh across the cable within 1us [TD.4.14.4.V.13]
30. CVSh and CVSd complete a U3 exit to U0 and waits 50ms
31. CVS completes TD 4.14.1 steps 14-15
32. If VIF field Cable_USB_Highest_Speed and Active_Cable_USB_Lanes indicate support for the Speed State in the next Section F Condition above, CVS continues to step 2 using the next Condition in section F.

TD 4.14.5 Cable USB4 Test

- A. Purpose:
 - 1. Check CPUT implements the Type-C cable state machine
- B. Applicability:
 - 1. This test is applicable for CPUTs where VIF field Product_Type is 4 (Active Cable)
- C. Asserts
 - 1. TBD - ECR
- D. Power State:
 - 1. CVS1 is CVSh, CVS2 is CVSD, Vconn Source 3V
 - 2. CVS2 is CVSh, CVS1 is CVSD, Vconn Source 3V
 - 3. CVS1 is CVSh, CVS2 is CVSD, Vconn Source 5.5V
 - 4. CVS2 is CVSh, CVS1 is CVSD, Vconn Source 5.5V
- E. Speed State:
 - 1. CVSh and CVSD communicate using USB4 Gen 2x1
 - 2. CVSh and CVSD communicate using USB4 Gen 2x2
 - 3. CVSh and CVSD communicate using USB4 Gen 3x2
- F. Conditions:
 - 1. Power State 1, Speed State 1 [TD.4.14.5.C.1]
 - 2. Power State 2, Speed State 1 [TD.4.14.5.C.2]
 - 3. Power State 3, Speed State 1 [TD.4.14.5.C.3]
 - 4. Power State 4, Speed State 1 [TD.4.14.5.C.4]
 - 5. Power State 1, Speed State 2 [TD.4.14.5.C.5]
 - 6. Power State 2, Speed State 2 [TD.4.14.5.C.6]
 - 7. Power State 3, Speed State 2 [TD.4.14.5.C.7]
 - 8. Power State 4, Speed State 2 [TD.4.14.5.C.8]
 - 9. Power State 1, Speed State 3 [TD.4.14.5.C.9]
 - 10. Power State 2, Speed State 3 [TD.4.14.5.C.10]
 - 11. Power State 3, Speed State 3 [TD.4.14.5.C.11]
 - 12. Power State 4, Speed State 3 [TD.4.14.5.C.12]
- G. Procedure:
 - 1. Test sets CVSh and CVSD according to Section F Condition 1 above.
 - 2. CVS completes TD 4.14.1 steps 1-8
 - 3. CVSh and CVSD complete a CL1_REQ transaction to enter CL1.
 - 4. CVSh transmits Ping.LFPS with max tBurst (200ns SS, 160ns SSP) every max tRepeat (240ms) in U1. This step continues for 550ms
 - 5. CVS verifies CPUT draws power \leq its CL0 power consumption while in CL1
 - 6. CVSD initiates the CL1 Exit LFPSs.
 - 7. CVS verifies it is forwarded across the cable within TODO
 - 8. CVSh and CVSD reach CL0 and waits 50ms
 - 9. CVSh and CVSD complete a CL2_REQ transaction to enter CL2. CVSh transmits Ping.LFPS every 250ms in U2. CVS waits 550ms
 - 10. CVS verifies CPUT draws power \leq its CL1 power consumption while in CL2
 - 11. CVSD initiates the CL2 Exit LFPSs
 - 12. CVS verifies it is forwarded across the cable within TODO
 - 13. CVSh and CVSD reaches CL0 and waits 50ms
 - 14. CVSh and CVSD set the Enter Sleep bit to 1b to enter CLd
 - 15. CVSh removes Vconn source.
 - 16. CVS verifies CPUT draws power \leq 20mW while in CLd.
 - 17. CVSD pulls SBTX to logical low for tWake to initiate retraining the link to CL0, reapplies Vconn source
 - 18. CVSh and CVSD train and reach CL0 and wait 50ms
 - 19. CVS completes TD 4.14.1 steps 14-15

20. If VIF field Cable_USB_Highest_Speed and Active_Cable_USB_Lanes indicate support for the Speed State in the next Section F Condition above, CVS continues to step 2 using the next Condition in section F.

Appendix A: TD Number Update

The Test Specification has been revised to include more connection tests as defined in the USB Type-C Spec 1.2. Effort has been made to maintain a test category taxonomy that is ontologically sound. As a result the Test Definitions have changed number indicator. The table below lists the previous tests and maps them to the current test numbers.

Test Name	Old TD Number	New TD Number
Initial Voltage Test	4.1	4.1.1
Source Connect Sink Test	4.2	4.2.1
Source Connect SNKAS Test	4.3	4.2.2
Source Connect DRP	4.4	4.2.3
Source Connect Audio Acc.	4.5	4.2.6
Source Connect Debug Acc.	4.6	4.2.7
Source Connect Vconn Acc.	4.7	4.2.8
Sink Connect Source Test	4.8	4.3.1
Sink Connect DRP Test	4.9	4.3.2
SNKAS Connect Source Test	4.10	4.4.1
SNKAS Connect DRP Test	4.11	4.4.2
SNKAS Connect Audio Acc.	4.12	4.4.6
SNKAS Connect Debug Acc.	4.13	4.4.7
SNKAS Connect PoweredAcc.	4.14	4.4.8
DRP Connect Sink Test	4.15	4.5.1
DRP Connect SNKAS Test	4.16	4.5.2
DRP Connect Source Test	4.17	4.5.3
DRP Connect DRP Test	4.18	4.5.4
DRP Connect Audio Acc. Test	4.19	4.8.1
DRP Connect Debug Acc. Test	4.20	4.8.2
DRP Connect Alternate Mode	4.21	4.8.3
DR_Swap Test	4.22	4.11.1
Vconn Powered Acc. Test	4.23	4.3.5 (Sink Connect SNKAS Test)

Source Suspend Test	4.24	4.9.1
USB Type-C Current Adv. Test	4.25	4.9.2
Source PR_Swap Test	4.26	4.9.3
Source Vconn_Swap Test	4.27	4.9.4
Source Alternate Mode Test	4.28	4.9.5
Legacy Host Adapter Test	4.29	Moved to EPC Test Spec
PD BFSK Capable Test	4.30	Removed
Sink Power Sub-States Test	4.31	4.10.1
Sink Power Precedence Test	4.32	4.10.2
Sink Suspend Test	4.33	4.10.3
Sink PR_Swap Test	4.34	4.10.4
Sink Vconn_Swap Test	4.35	4.10.5
Sink Alternate Mode Test	4.36	4.10.6
PD BFSK Capable Test	4.37	Removed
Sink Dead Battery Test	4.38	4.11.2
Hub Port 3.1 Test	4.39	4.12.1
Hub Port Types Test	4.40	4.12.2

Appendix B: USB-IF Results Schema

The Compliance Test results Shall be output in XML format, compliant with the official USB-IF schema.:

<https://compliance.usb.org/xsd/USB/DataCollection.xsd>

A component element Shall be created to reflect the VIF component tested

Under the testRun node:

- The following values Shall be set within the spec element:
 - title: “USB Type-C Functional Test Specification”
 - version: Text shall match the document revision # found at the top of the page or title page of this document (e.g. “0.86”)
- A test element Shall be created for each Test
 - The tcID attribute Shall match the test number (e.g. “TD.4.2.1”)
- A condition element Shall be created for every condition for each test.
 - Throughout the test definitions, conditions are identified with [TD.4.x.x.C.x].
 - If no conditions are listed in the test definition, a single element is used with its identification set to [TD.4.x.x.C.0].
 - The condition title element shall match its identification (e.g. “TD.4.x.x.C.x”)
- A step element Shall be created for every verification step of each condition element.
 - Throughout the test definitions, verification steps are identified with [TD.4.x.x.V.x]
 - The step title element shall match its identification (e.g. “TD.4.x.x.V.x”)
 - If the verification step fails, the score element Shall be set to Fail.

- A comment element Shall be used to provide detail on the nature of each failure. The format in which this is done may be determined by the test vendor.