

USB 80G PHY Layer Analysis

USB-IF Electrical Workgroup

Agenda

- Requirements
- Deriving FEC Characteristics
- Deriving Uncoded BER Specifications
- PHY Modulation Analysis

Requirements

Goal: double USB4 link speed with the existing ecosystem constraints

- **Data Rate:** 80G gross rate with traffic available bandwidth $\geq 76\text{Gb/s}$
- **Data Integrity:** BER $< 1\text{E-}19$
- **Latency:** FEC latency $< 150\text{ns}$
- **USB-C Compatibility:** Same cables, connectors, and PCB as in USB 40G

USB-C Channels

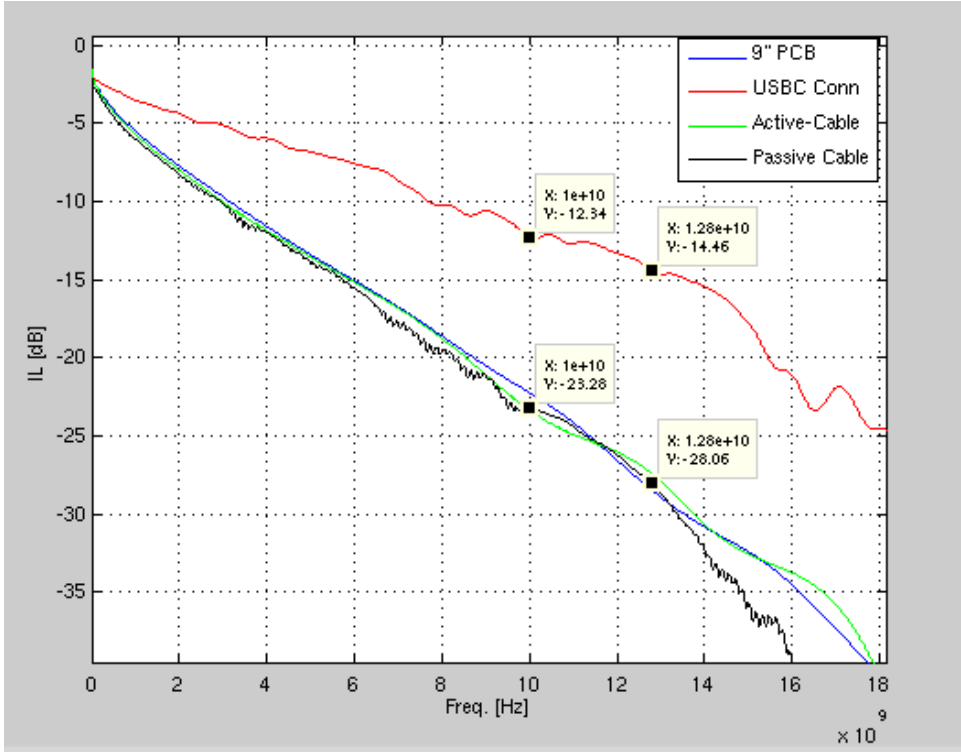
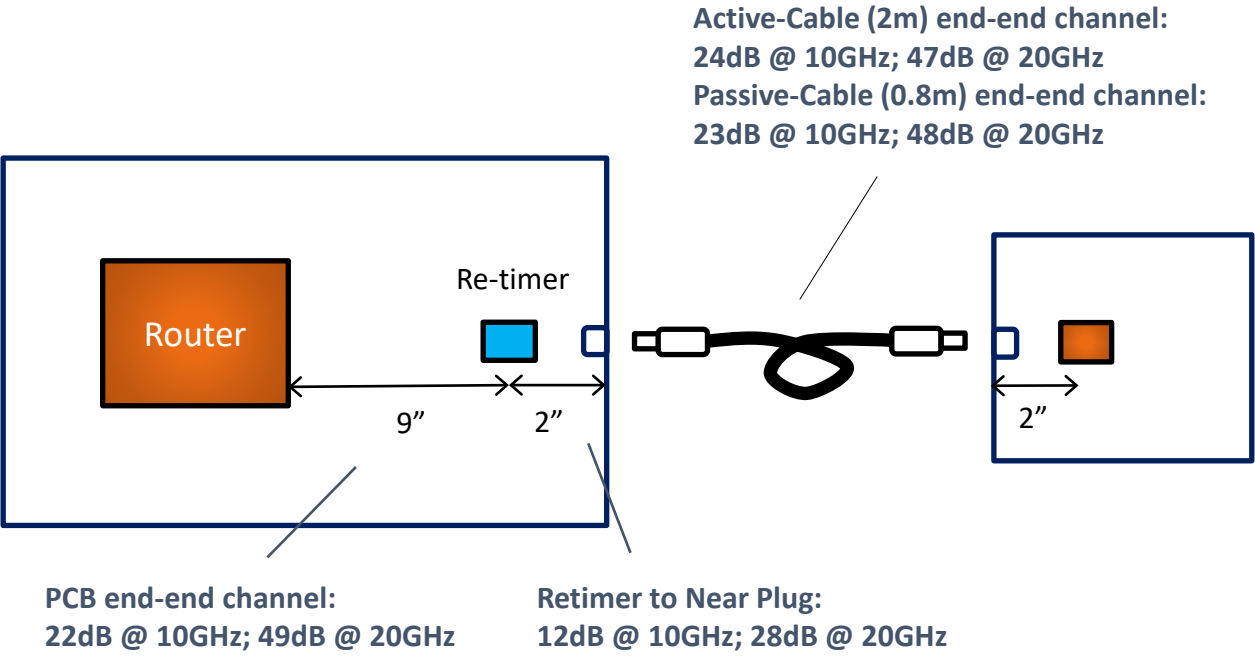

- Worst-Case reference model:

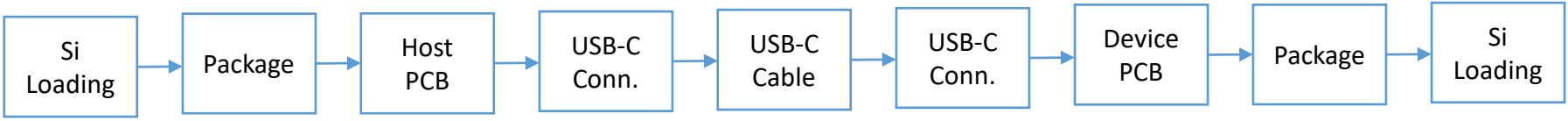

RS-FEC Specifications

- RS-FEC requirements for meeting BW efficiency and latency specs:

(*) **Latency** $\leq 150\text{ns}$ $\rightarrow N_{\text{BLK}} * 10 * 12.5\text{ps} + N_{\text{EC}} * 6\text{ns} \leq 150\text{ns}$

(**) **Efficiency** $\geq 95\%$ $\rightarrow 2 * N_{\text{EC}} / N_{\text{BLK}} \leq 0.05$

// N_{BLK} is the block size, N_{EC} is the number of error-corrections per block

// Assumptions: 10 bits per symbols; 6ns per error correction

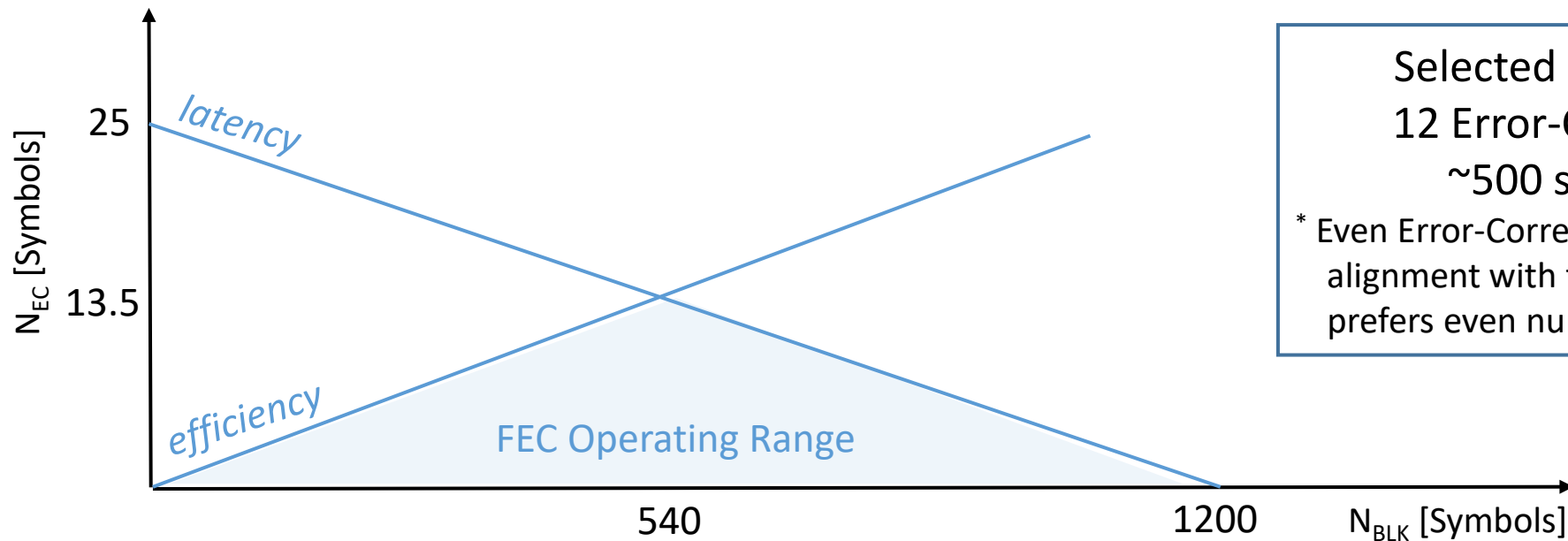

Deriving the Uncoded BER Specifications (1)

- Analysis performed for deriving the relation between the uncoded BER and the FEC error corrections, given coded BER of $1E-19$
- The calculation includes the following parameters:
 - Number of Error corrections
 - Uncoded BER (uncorrelated errors)
 - Block Size
 - RS symbol size
 - Pre-coding (“integrative” pre-coder addressing DFE error bursts)
 - Number of Re-timers
 - DFE error propagation probability
 - Burst restart probability (probability that a burst which ended will restart)

Deriving the Uncoded BER Specifications (2)

- The analysis defines the required number of error corrections per different input BER levels such that: $10^{-19} > \frac{1}{N_{BLK}} \cdot \sum_i \{FEC\ failure\ event_i\}$
- “Safe zone” between the FEC input BER and the PHY uncoded BER added for budgeting correlated error effects that cannot be modeled and obtaining margin in the system level
 - Experience from the Networking segment indicates that most of the Ethernet vendors require 2.4 orders of magnitude as “safe zone” margin
 - In this work, 2 orders of magnitude are assumed (although USB segment has more interop challenges due to its huge volumes and large variety of multi-vendor links)

Deriving the Uncoded BER Specifications (3)

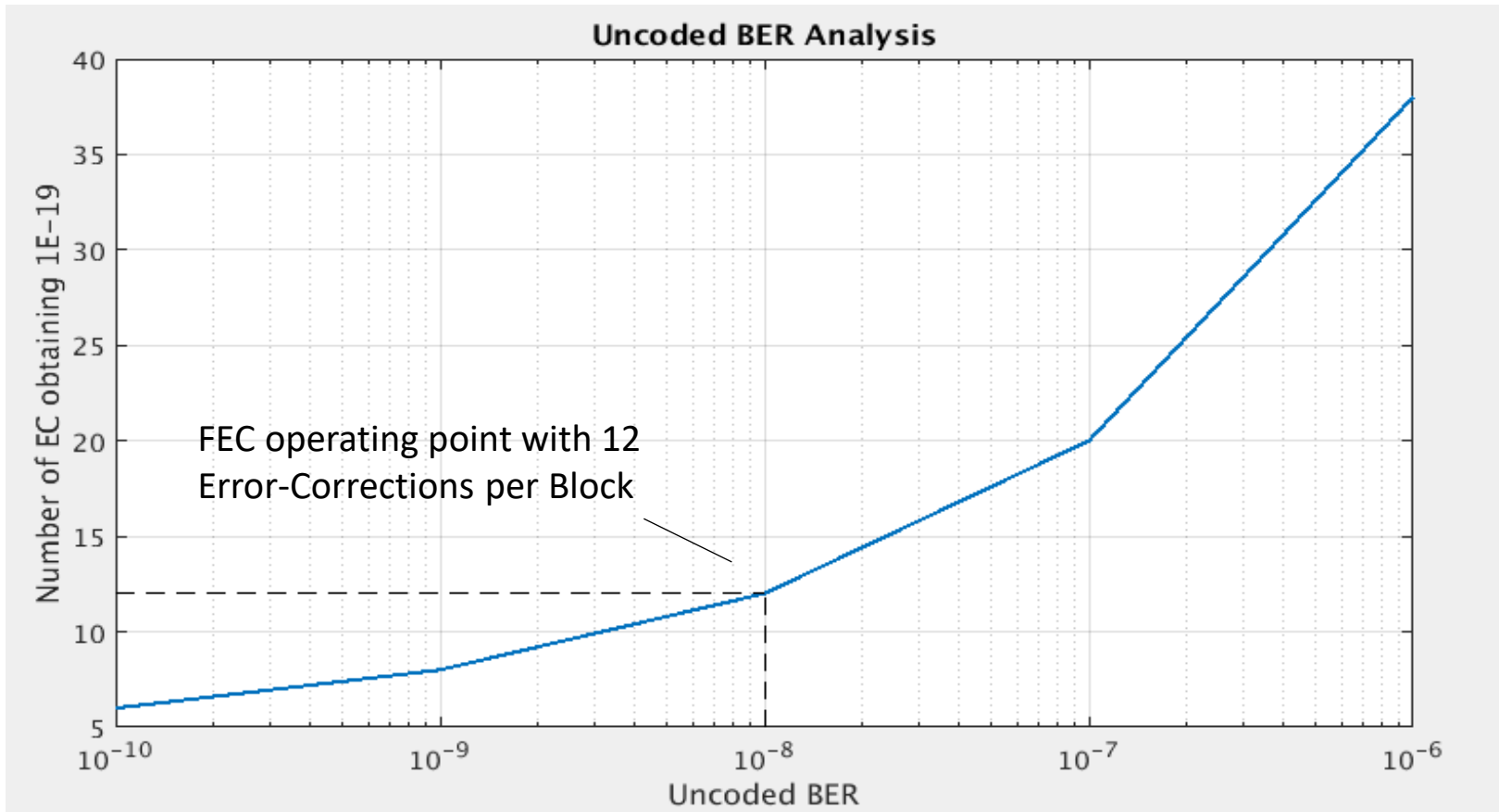

Uncoded BER=1E-8 shall be targeted for enabling FEC with 12 Error-Corrections

PHY Modulation Analysis

- PAM-3 and PAM-4 modulations were examined using USB-C channel models
 - PAM-2 is not applicable as the frequency is too high; non-differential methods also examined but not applicable due to the mode conversion of the connector

Modulation	Baud Rate [GB]	Levels Separation	Comments
PAM-3	25.6	0.5	Each symbol carries 1.57 bits ⁽¹⁾
PAM-4	20.0	0.33	Each symbol carries 2 bits

⁽¹⁾ Realized by a simple 11bits-to-7trits mapping obtaining >99% efficiency of the theoretical $\log_2(3)=1.58$ bits/symbol limit

PAM-2
1bit/Symbol
Rate: 40GB
Margin: 1

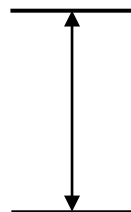

PAM-3
1.57bits/Symbol
Rate: 25.6GB
Margin: 0.5

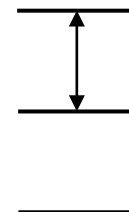

PAM-4
2bits/Symbol
Rate: 20GB
Margin: 0.33

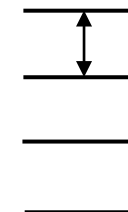

USB Reference Channels: Background

- Each end-to-end channel model consists of five models corresponding to sections of USB end-to-end channel, as shown below:

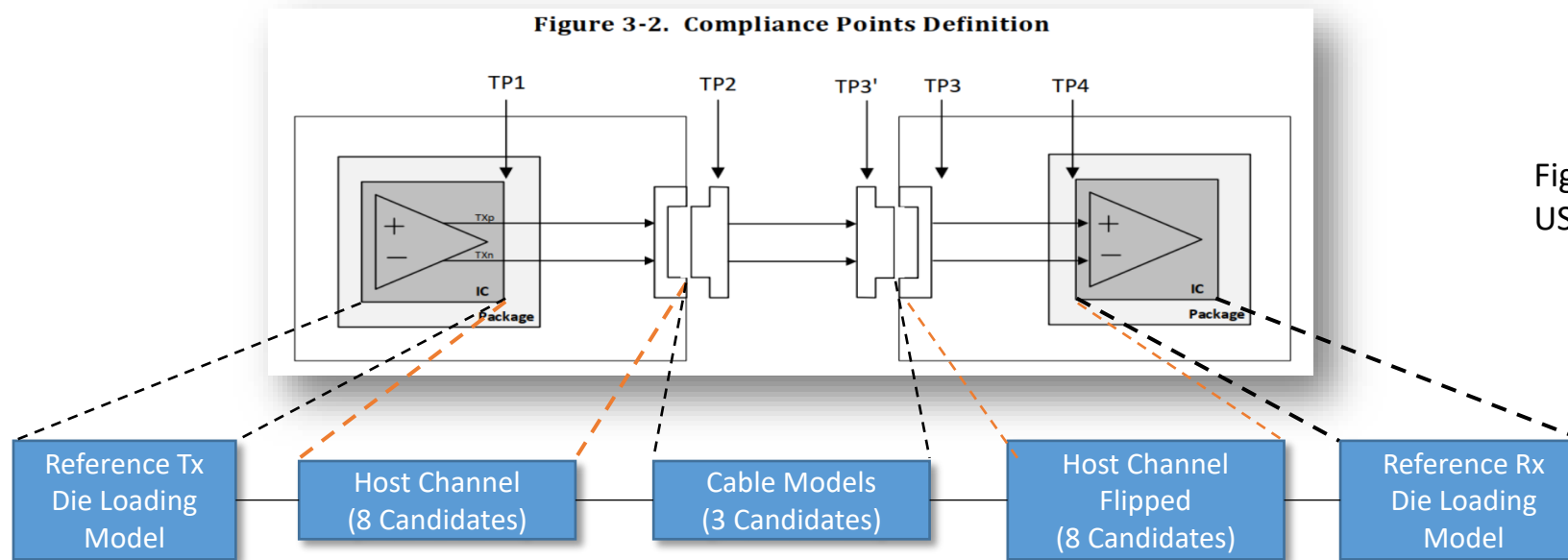
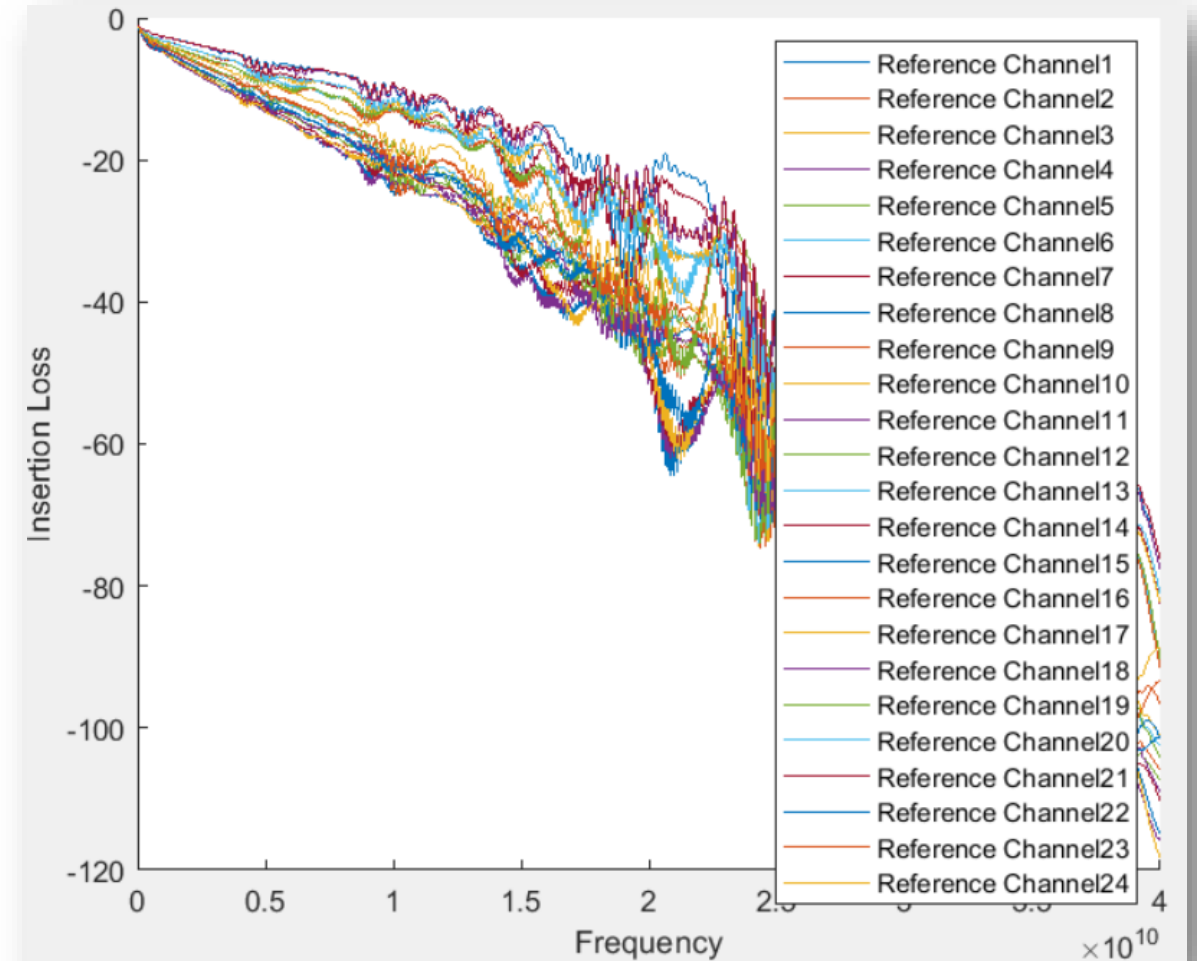

Figure 3-2
USB4™ Spec

End-to-End Channel Characteristics: IL

End-to-end Channel	IL Fit @ 12.8GHz [dB]	IL Fit @ 10.0GHz [dB]	End-to-end Channel	IL Fit @ 12.8GHz [dB]	IL Fit @ 10.0GHz [dB]
1	-29.40	-23.55	13	-18.55	-13.09
2	-27.67	-22.14	14	-16.78	-11.09
3	-25.61	-20.14	15	-14.45	-14.93
4	-29.27	-23.53	16	-18.71	-13.38
5	-27.54	-22	17	-16.94	-11.38
6	-25.53	-20.13	18	-14.61	-14.63
7	-27.66	-22.44	19	-18.27	-13.08
8	-25.93	-20.92	20	-16.5	-11.08
9	-24.01	-19.06	21	-14.17	-20.74
10	-27.66	-22.55	22	-25.98	-19.32
11	-25.94	-21.03	23	-24.50	-17.32
12	-23.99	-19.03	24	-22.18	-13.09



End-to-End Channel Characteristics: XTALK

Far-End Cross Talk

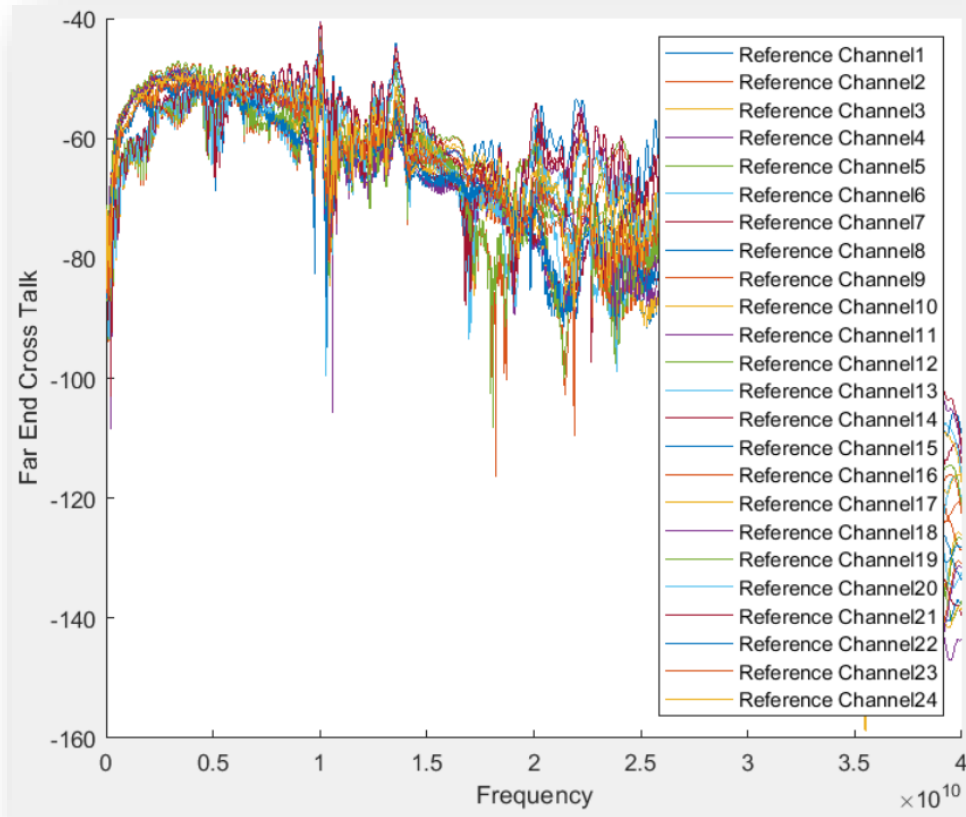

Near-End Cross Talk

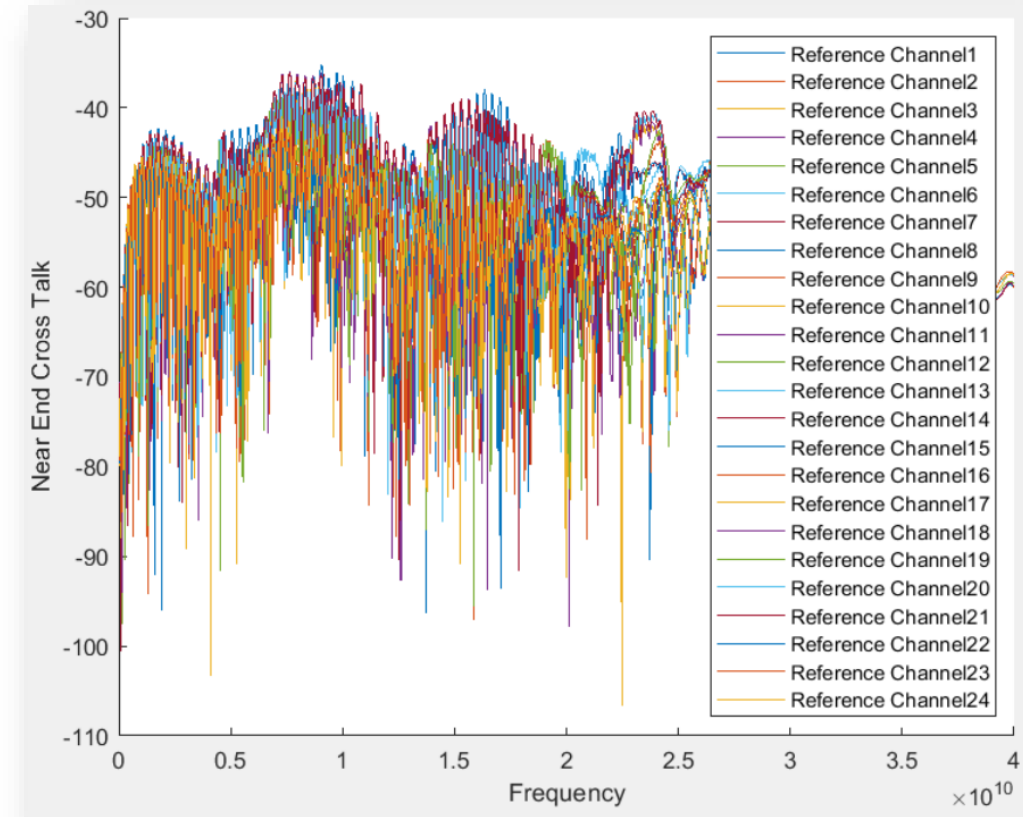

Simulations Results: Summary

- Simulations were performed using eCOM analysis tool (details below)
- PAM-3 modulation was identified as the only direction that enables supporting un-coded BER of $1E-8$

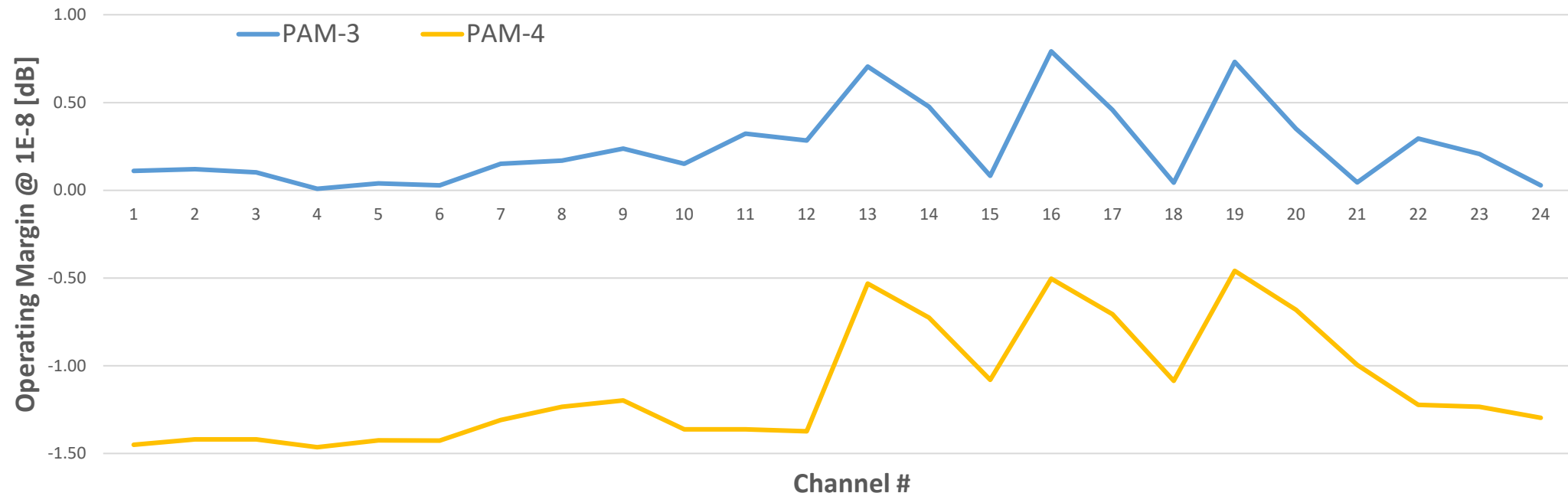

Simulations Results: Details

- Simulations results over 24 reference USB Type-C channels:

PAM3

	Host	1			2			3			4			5			6			7			8		
	Cable	1	4	7	1	4	7	1	4	7	1	4	7	1	4	7	1	4	7	1	4	7	1	4	7
Operating Margin [dB]	1.0E-08	0.11	0.12	0.10	0.01	0.04	0.03	0.15	0.17	0.24	0.15	0.32	0.28	0.71	0.48	0.08	0.79	0.46	0.04	0.73	0.35	0.04	0.30	0.21	0.03
	1.0E-07	0.67	0.68	0.66	0.57	0.60	0.59	0.70	0.73	0.79	0.70	0.87	0.83	1.23	1.01	0.62	1.32	0.98	0.58	1.25	0.86	0.58	0.85	0.77	0.58
	1.0E-06	1.32	1.35	1.33	1.22	1.26	1.24	1.34	1.37	1.45	1.33	1.50	1.47	1.87	1.64	1.25	1.94	1.61	1.20	1.86	1.48	1.21	1.50	1.42	1.24

PAM4

	Host	1			2			3			4			5			6			7			8		
	Cable	1	4	7	1	4	7	1	4	7	1	4	7	1	4	7	1	4	7	1	4	7	1	4	7
Operating Margin [dB]	1.0E-08	-1.45	-1.42	-1.42	-1.47	-1.43	-1.43	-1.31	-1.23	-1.20	-1.36	-1.36	-1.37	-0.53	-0.73	-1.08	-0.50	-0.71	-1.09	-0.46	-0.68	-1.00	-1.22	-1.23	-1.30
	1.0E-07	-0.87	-0.85	-0.84	-0.88	-0.85	-0.85	-0.73	-0.67	-0.62	-0.79	-0.79	-0.80	0.03	-0.17	-0.52	0.07	-0.14	-0.52	0.11	-0.12	-0.44	-0.65	-0.66	-0.72
	1.0E-06	-0.18	-0.17	-0.16	-0.19	-0.17	-0.17	-0.04	0.00	0.05	-0.12	-0.12	-0.13	0.68	0.47	0.13	0.73	0.51	0.13	0.76	0.54	0.22	0.03	0.02	-0.05

Summary

- Different modulation technologies were examined for meeting the goal of doubling USB link speed with the existing ecosystem constraints
- The analysis indicates that PAM-3 is the only modulation technology that supports un-coded $BER < 1E-8$, which meets USB 80G goals
 - Meaningfully better performance than all other options over USB channels
 - PHY architecture/design is similar between PAM-3/PAM-4 (PAM-3 slightly simpler)
 - PAM-3 is a novel direction, yet test equipment already available

Performance Analysis Details

Analysis Method: eCOM Tool Background

$$eCOM = 20 * \log_{10}\left(\frac{A_s}{A_s - eh}\right)$$

- eCOM, or enhanced COM is developed based on the COM industry tool, which is widely used in the Ethernet segment.
- eCOM adds all Rx impairments such that the pass/fail criterion is eCOM = 0 dB
 - COM includes mostly Tx impairments.
- eCOM handles jitter more rigorously
 - COM uses the pulse response slope to approximate jitter impact, which may cause significant error when jitter is not small.
- eCOM has been correlated with TD simulations and with other statistical analysis tools.

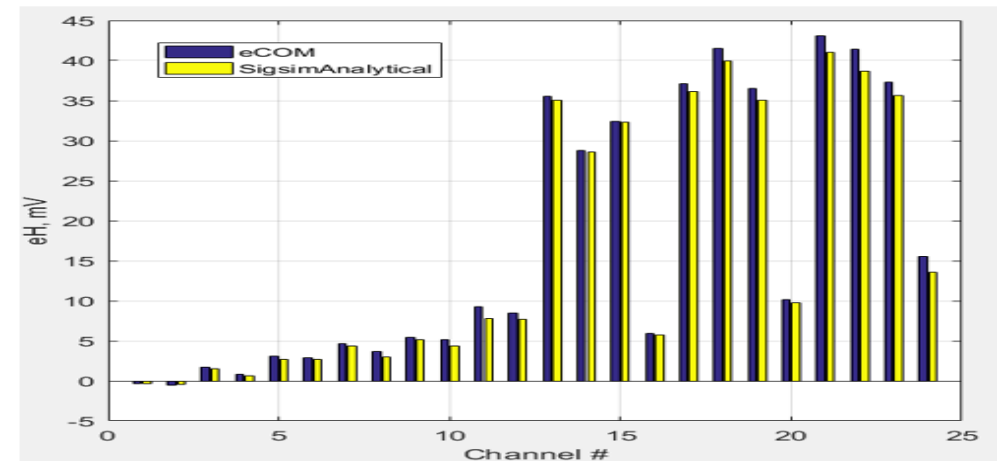
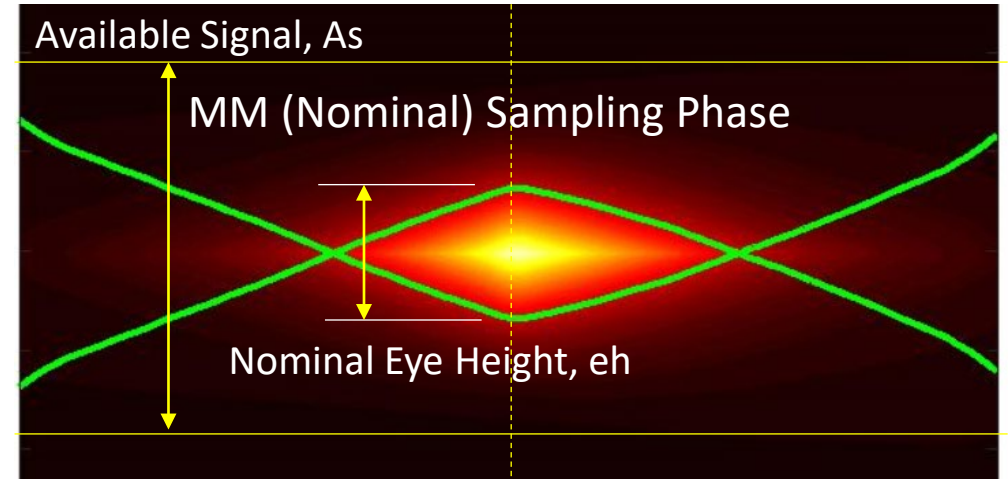

eCOM Reference Model

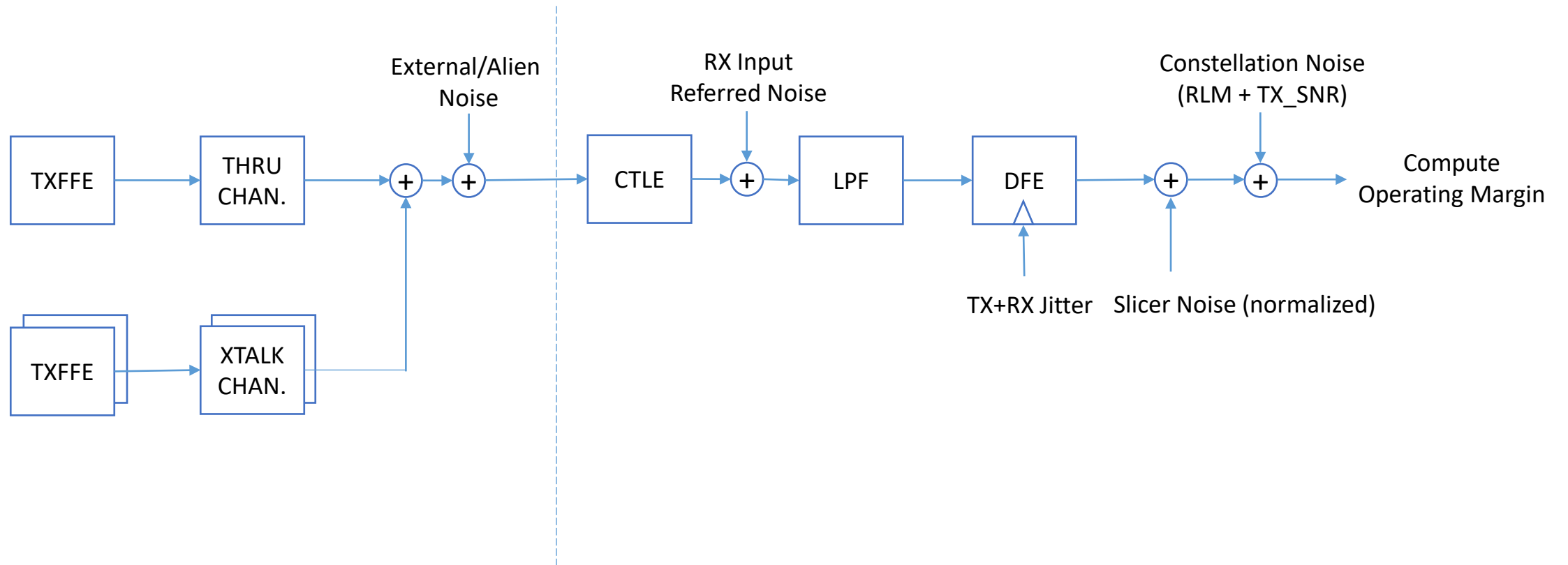

Simulation Setup (1)

Parameter	PAM-3	PAM-4
Baud Rate	25.6GB	20.0GB
Channel	THRU, FEXT, 2 x NEXT	THRU, FEXT, 2 x NEXT
TX Voltage Swing	0.8V pk-pk	0.8V pk-pk
FEXT Voltage Swing	0.8V pk-pk	0.8V pk-pk
NEXT Voltage Swing	1V pk-pk	1V pk-pk
Rise Time	8ps	8ps
TXFFE Configuration	LSB: $C_{-2}=0.025$ $C_{-1}/C_1=0.05$	LSB: $C_{-2}=0.025$ $C_{-1}/C_1=0.05$
TX Uncorrelated DJ	0.08UI pk-pk	0.0625UI pk-pk
TX RJ	0.0075UI rms	0.0075UI rms
TX Levels Mismatch	0.975	0.95
TX SNDR	32.5dB	32.5dB
Alien Noise (AWGN)	$1.64E-8$ V ² /GHz	$1.64E-8$ V ² /GHz

Simulation Setup (2)

Parameter	PAM-3	PAM-4
CTLE Stage1 pole	Fbaud/2.5	Fbaud/2.5
CTLE Stage1 boost	-12:1:0 dB	-12:1:0 dB
CTLE Stage2 pole	Fbaud/80	Fbaud/80
CTLE Stage2 boost	-6:1:0 dB	-6:1:0 dB
RX BW	0.75*Fbaud	0.75*Fbaud
DFE taps	12	12
RX DJ (open loop)	0.032UI pk-pk	0.025UI pk-pk
RX RJ (open loop)	0.0075UI rms	0.0075UI rms
RX CDR tracking jitter	0.01UI rms	0.01UI rms
RX Amp. Input Referred Noise	1.3E-8 V ² /GHz	1.3E-8 V ² /GHz
Random Noise at RX Slicer	2.23mV rms	2.23mV rms
Deterministic Noise at RX slicer	10.3mV pk	8.5mV pk

Channel Models

- Thru differential channel
- 1 FEXT differential channel
- 2 NEXT differential channels

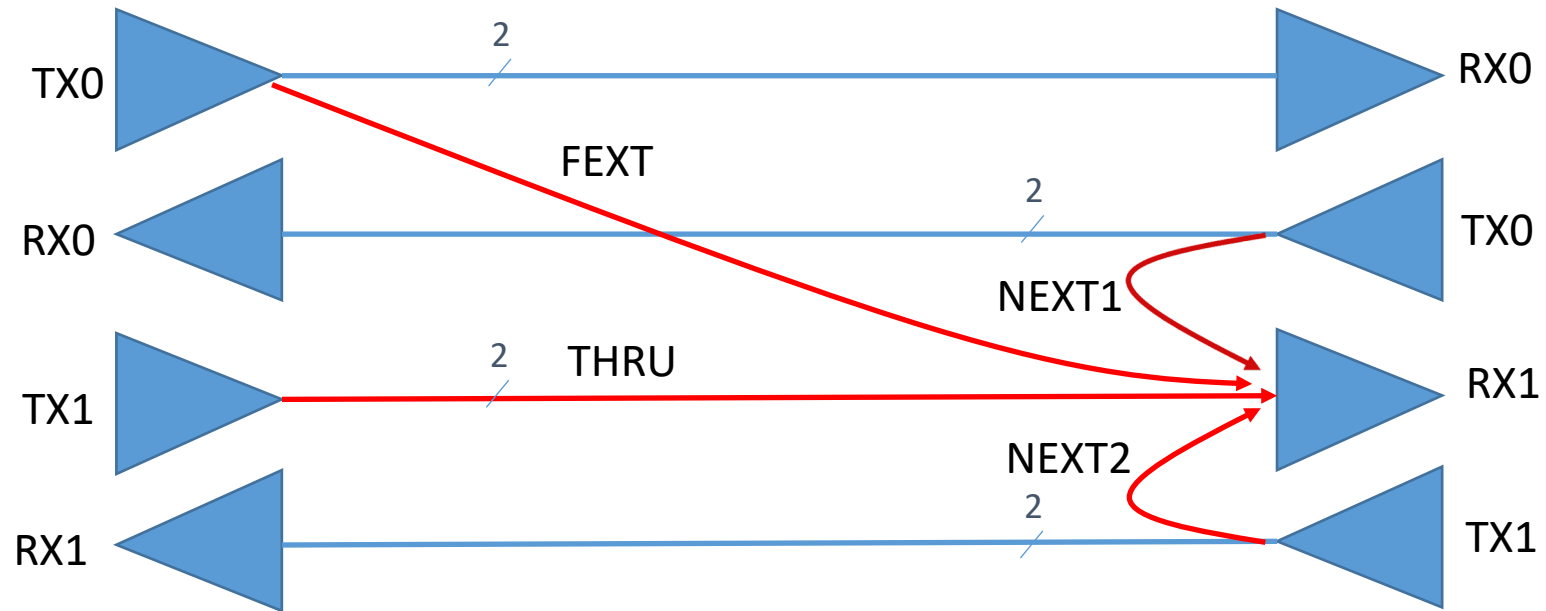

Transmitter Reference Model: Baseline

- Baud Rate: 20.0GB (PAM-4), 25.6GB (PAM-3)

- PAM-3: 1.57 bits/symbol, PAM-4: 2 bits/symbol

- TX Voltage Swing:

- THRU: 0.8V pk-pk
- FEXT: 0.8V pk-pk
- NEXT: 1V pk-pk

Far-side with minimum transmitter swing (THRU+FEXT)
Near side with maximum transmitter swing (NEXT)

- TX FFE:

- 4 FIR taps (2 pre-cursor and 1 post-cursor taps)
- 0.05 LSB step for taps $C[-1]$, $C[1]$; 0.025 LSB step for tap $C[-2]$; $\sum |C[i]| = 1$

- Same as IEEE Ethernet standards

Transmitter Reference Model: Jitter

- Deterministic Jitter: 3.125ps pk-pk (2.3ps UDJ, 0.8ps TX DCD)
 - 0.08UI pk-pk (PAM-3), 0.0625UI pk-pk (PAM-4)

- TX+PLL circuitry: 1.9ps pk-pk
- Residual SSC: 0.4ps pk-pk
- Re-timer's PLL noisy refclk: 0.2ps pk-pk
- Low frequency jitter forwarding: $2 \times 0.3\text{ps} = 0.6\text{ps}$ pk-pk

- Random Jitter: 0.0075UI RMS

- The phase noise scales with the rate (constant in radians)

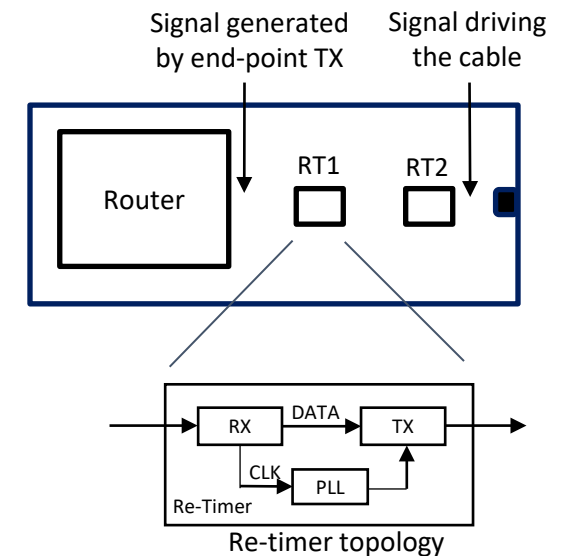

Transmitter Reference Model: Voltage Noise

- Levels Mismatch (R_{LM}): 0.975 (PAM-3), 0.95 (PAM-4)

- PAM-4 R_{LM} is the same as IEEE Ethernet standards, PAM-3 R_{LM} assumes the same level mismatch error as PAM-4 plus some additional benefit of its symmetrical structure:
 - The R_{LM} error ($=1-R_{LM}$) is the ratio between the levels differential mismatch and the ideal levels difference. Since in PAM-3 the ideal levels difference is 1.5x larger than in PAM-4, same amount of mismatch will translate into 1.5x smaller R_{LM} error
 - PAM-3 has symmetrical structure which decreases the levels differential mismatch compared to PAM-4 (PAM-3 inner level is generated by applying the same voltage on TXp and TXn providing better impedance matching than PAM-4 where TXp \neq TXn)

- Dynamic Non-Linearity (TX_{SNDR}): 32.5dB

- Same as IEEE Ethernet standards
- It shall be noted that the USB setup is more challenging due to the tighter power and noise levels constraints

RX Reference Model: Jitter

- RX DJ (open loop): 1.25ps pk-pk
 - 0.032UI pk-pk (PAM-3), 0.025UI pk-pk (PAM-4)
 - Not including the CDR tracking jitter
- RX RJ: 0.0125UI RMS
 - CDR loop tracking jitter modeled with 0.01UI RMS Gaussian PDF (scales with the rate)
 - Phase noise: 0.0075UI RMS (scales with the rate)

RX Reference Model: Equalization

- CTLE:

$$H(s) = \frac{(s + 2\pi f_{LP} \cdot A_{DC_LP})}{(s + 2\pi f_{LP})} \cdot \frac{f_{p1} \cdot (s + 2\pi f_{z1} \cdot A_{DC_1})}{f_{z1} \cdot (s + 2\pi f_{p1})} \cdot \frac{2\pi f_{p2}}{(s + 2\pi f_{p2})}$$

Nominal setting: $f_{LP} = F_{baud}/80$

Nominal setting: $f_{p1} = f_{z1} = F_{baud}/2.5$

Nominal setting: $f_{p2} = F_{baud}$

- Receiver bandwidth limitation: 4 poles at $0.75 * F_{baud}$
- DFE: 12 taps
 - Taps Range (normalized to the cursor): tap1: 0 – 0.75, tap2-12: -0.2 – 0.2
 - The DFE quantization error is represented by Gaussian noise with $\sigma=1\text{mV}$ at the slicer input (and normalized back to the CTLE output by eCOM)
 - Assuming 1mV DFE tap resolution, the quantization error is uniformly distributed between [-0.5mV, 0.5mV]. Therefore, the RMS error per tap is of $1/\sqrt{12}$ mV, and the total RMS error for 12 independent taps is of $1/\sqrt{12} \times \sqrt{12} = 1\text{mV}$ (PDF is close to be Gaussian)

RX Reference Model: Additive Noise

- External/Alien noise (spectral density): $1.64\text{E-}8 \text{ V}^2/\text{GHz}$

- Same as IEEE Ethernet Standards

- RX internal noise (spectral density): $1.3\text{E-}8 \text{ V}^2/\text{GHz}$

- Modeling the added thermal noise of the receiver gain stages
- The input referred noise associated with the receiver gain stages is almost independent of the specific receiver design as it is mostly dominated by the noise of the first stage only

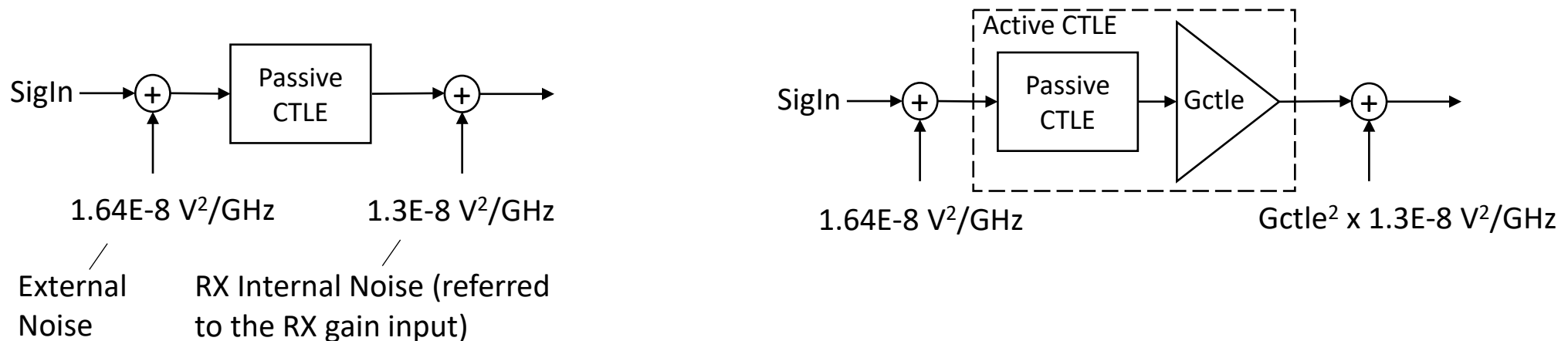

RX Reference Model: Slicer Noise

- Slicer Sensitivity: 5mV peak (PAM-3), 4mV peak (PAM-4)

- Assumed to be slightly lower for PAM-4 due to the larger decision time
- Eye width (integration window) is higher in PAM-3

- Slicer Offset: 3mV peak

- Accounted for slicer calibration inaccuracies and temperature related offsets

- Slicer AWGN: 2.2mV RMS

- Latch noise: 2mV RMS
- DFE finite tap resolution: 1mV RMS

RX Reference Model: Non-Linearity

- Non-Linearity Effects: 2.3mV peak (PAM-3), 1.5mV peak (PAM-4)

- Values are based on simulation data
- PAM-4 is more sensitive to non-linearity effects as its constellation being impacted by both the DFE taps and the AGC gain distortion while PAM-3 constellation is impacted only by the DFE taps error
- On the other hand, the DFE dynamic range tends to be smaller in PAM-4 compared to PAM-3 as the Nyquist insertion-loss is smaller

eCOM Simulation Setup: PAM3

System Level Settings			
Parameter	Setting	Units	Information
IO_interface	CIO80		Interface tag
f_b	25.6	GBd	Baud Rate
L	3		Number of constallation levels
DER_0	1.00E-08		Target uncoded symbol error rate
COM Pass threshold	0	dB	0 dB for CIO80. 3 dB for IEEE standards
TX EQ Settings			
ffe_preset	0.025 -0.2 -0.1;0.025 -0.2 -		TXFFE preset configurations
RX EQ Settings			
g_DC	[-12:1:0]	dB	CTLE stage1 (high pole) DC attenuation
g_DC_HP	[-6:1:0]		CTLE stage2 (low pole) DC attenuation
f_HP_PZ	0.32	GHz	CTLE stage2 pole location
f_z	10.24	GHz	CTLE stage1 zero location
f_p1	10.24	GHz	CTLE stage1 first pole location
f_p2	25.6	GHz	CTLE stage1 second pole location
N_b	12	UI	Number of DFE taps
b_max(1)	0.75		Dynamic range limitation for the DFE first tap (referenced to the main cursor)
b_max(2..N_b)	0.2		Dynamic range limitation for the DFE taps 2 and above (referenced to the main cursor)
TX and RX Jitter			
A_DDtx	0.0128	UI	Transmitter bimodal jitter
sigma_RJtx	0.0075	UI	Transmitter RJ RMS
SJtx	0.0272	UI	Transmitter sinusoidal jitter
A_DDrx	0.016	UI	Receiver bi-modal jitter
sigma_RJrx	0.0125	UI	Receiver RJ RMS
TX and RX Noise			
SNR_TX	32.5	dB	Transmitter dynamic non-linearity: same as IEEE 802.3cd (latest Ethernet spec)
eta_0	1.64E-08	V ² /GHz	External/Alien noises: same as IEEE 802.3cd (latest Ethernet spec)
eta_rx	1.30E-08	V ² /GHz	AFE input referred AWGN (post CTLE)
slc_awgn	1.86E-02		Rx Gaussian noise ratio (to Vref). Actual noise = X * Cursor.
slc_det_noise	0.085833333		Receiver deterministic noise ratio (to Vref): 5mV slicer sensitivity plus 3mV slicer offset plus 2.3mV non-linearity (referenced to +/-120mV slicer dynamic range). =0.0858333 for
Swing and R_LM			
A_v	0.4	V	THRU transmitter peak voltage swing
A_fe	0.4	V	FEXT aggressor peak voltage swing
A_ne	0.5	V	NEXT aggressor peak voltage swing
R_LM	0.975		Transmitter static non-linearity: based on IEEE 802.3cd (latest Ethernet spec)
TX and RX Filter			
T_r	8.00E-03	ns	Rise time, used to apply a Tx filter
f_r	0.75	*fb	Receiver bandwidth
INCLUDE_TX_RX_FILTER	1	logical	

eCOM Simulation Setup: PAM4

System Level Settings			
Parameter	Setting	Units	Information
IO_interface	CIO80		Interface tag
f_b	20	GBd	Baud Rate
L	4		Number of constellation levels
DER_0	1.00E-08		Target uncoded symbol error rate
COM Pass threshold	0	dB	0 dB for CIO80. 3 dB for IEEE standards
TX EQ Settings			
ffe_preset	0.025 -0.2 -0.1;0.025 -0.2 -		TXFFE preset configurations
RX EQ Settings			
g_DC	[-12:1:0]	dB	CTLE stage1 (high pole) DC attenuation
g_DC_HP	[-6:1:0]		CTLE stage2 (low pole) DC attenuation
f_HP_PZ	0.25	GHz	CTLE stage2 pole location
f_z	8	GHz	CTLE stage1 zero location
f_p1	8	GHz	CTLE stage1 first pole location
f_p2	20	GHz	CTLE stage1 second pole location
N_b	12	UI	Number of DFE taps
b_max(1)	0.75		Dynamic range limitation for the DFE first tap (referenced to the main cursor)
b_max(2..N_b)	0.2		Dynamic range limitation for the DFE taps 2 and above (referenced to the main cursor)
TX and RX Jitter			
A_DDtx	0.01	UI	Transmitter bimodal jitter
sigma_RJtx	0.0075	UI	Transmitter RJ RMS
SJtx	0.02125	UI	Transmitter sinusoidal jitter
A_DDrx	0.0125	UI	Receiver bi-modal jitter
sigma_RJrx	0.0125	UI	Receiver RJ RMS
TX and RX Noise			
SNR_TX	32.5	dB	Transmitter dynamic non-linearity: same as IEEE 802.3cd (latest Ethernet spec)
eta_0	1.64E-08	V ² /GHz	External/Alien noises: same as IEEE 802.3cd (latest Ethernet spec)
eta_rx	1.30E-08	V ² /GHz	AFE input referred AWGN (post CTLE)
slc_awgn	1.86E-02		Rx Gaussian noise ratio (to Vref). Actual noise = X * Cursor.
slc_det_noise	0.070833333		Receiver deterministic noise ratio (to Vref): 5mV slicer sensitivity plus 3mV slicer offset plus 2.3mV non-linearity (referenced to +/-120mV slicer dynamic range).
Swing and R_LM			
A_v	0.4	V	THRU transmitter peak voltage swing
A_fe	0.4	V	FEXT aggressor peak voltage swing
A_ne	0.5	V	NEXT aggressor peak voltage swing
R_LM	0.95		Transmitter static non-linearity:same as IEEE 802.3cd (latest Ethernet spec)
TX and RX Filter			
T_r	8.00E-03	ns	Rise time, used to apply a Tx filter
f_r	0.75	*fb	Receiver bandwidth
INCLUDE_TX_RX_FILTER	1	logical	

Backup

Pre-Coding (PAM-N)

- Functionality:

- Encoding: $y[n] = \text{MOD}(-y[n-1] + x[n], N) = -y[n-1] + x[n] + a*N \ // \ x, y \in \{0, 1, \dots, N-1\}; a \in \mathbb{Z}$
- Decoding: $\text{MOD}(y[n] + y[n-1], N) = \text{MOD}(-y[n-1] + x[n] + a*N + y[n-1], N) = x[n]$

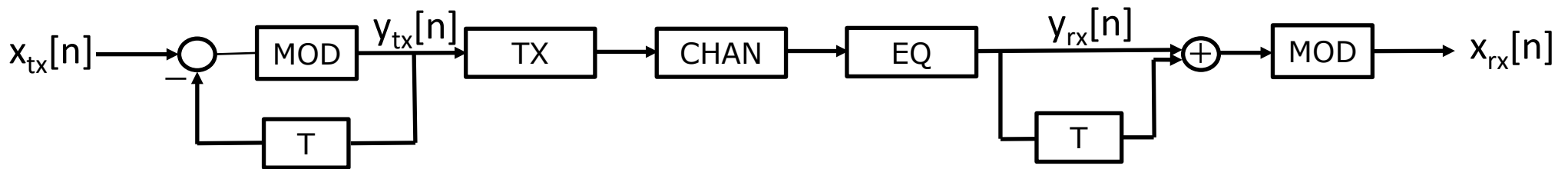

- Provides mitigation for DFE error propagation effects:

- if $y_{rx}[n-1] = y_{tx}[n-1] \pm 1$ then the DFE correction for the next symbol will create error at the opposite direction such that $y_{rx}[n] = y_{tx}[n] \mp 1$ (assuming DFE tap1 > 0).

Therefore: $\text{MOD}(y[n] \pm 1 + y[n-1] \mp 1, N) = \text{MOD}(y[n] + y[n-1], N) = x[n]$

Pre-Coding (PAM-N) (cont'd)

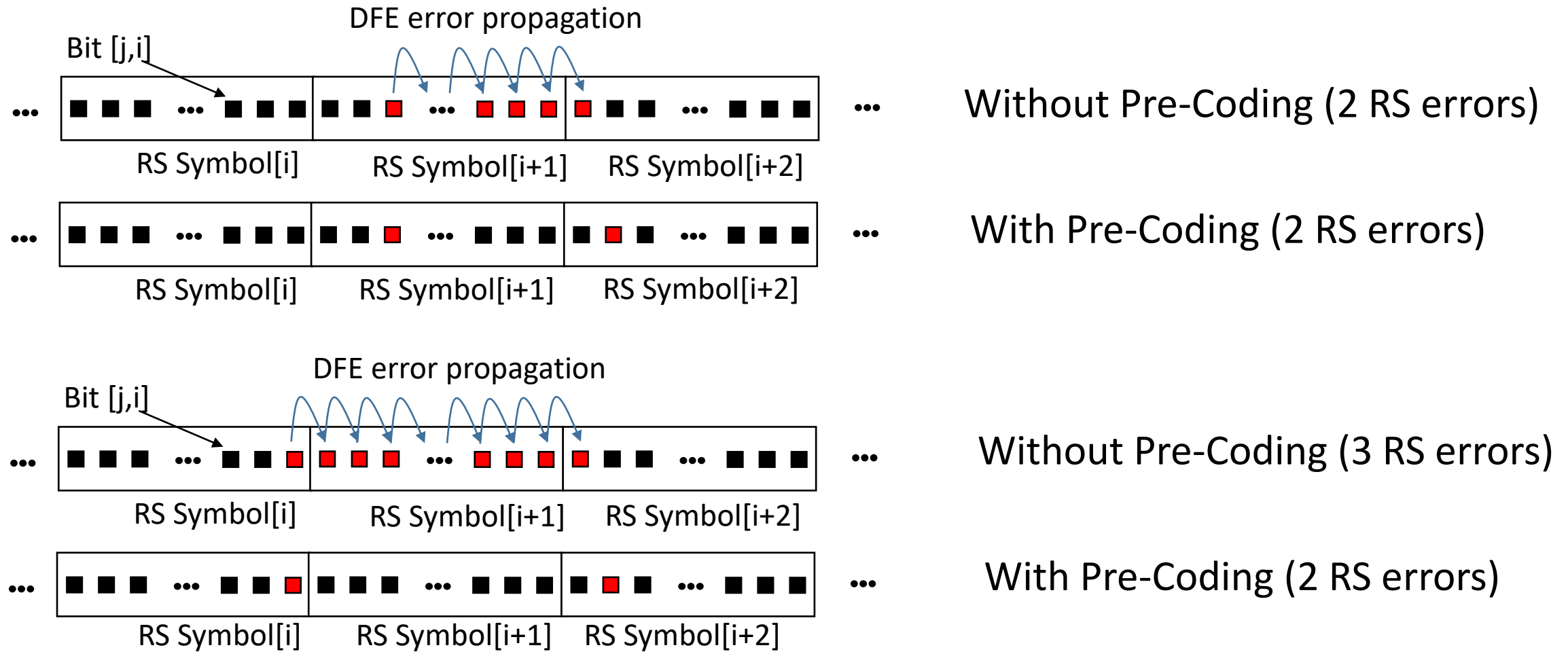

PAM-M Simulation Results: Analysis

- The signal headroom is defined by the distance between the constellation levels (proportional to $1/(L-1)$, where L is the number of levels)
- Empirical results indicate that the noise is approx. scaled according to the baud rate (which is proportional to $1/\log_2(L)$)
- As a result, the operating margin is proportional to the ratio between the levels distance and the rate ($\log_2(L)/(L-1)$)
- Therefore, PAM-3 gains SNR Margin of 1.4dB over PAM-4:
 - $(0.5/25.6G)/(0.33/20G)=1.4\text{dB}$
 - Signal scaling: $0.5/0.33=1.5x$
 - Noise scaling: $25.6G/20G=1.28x$

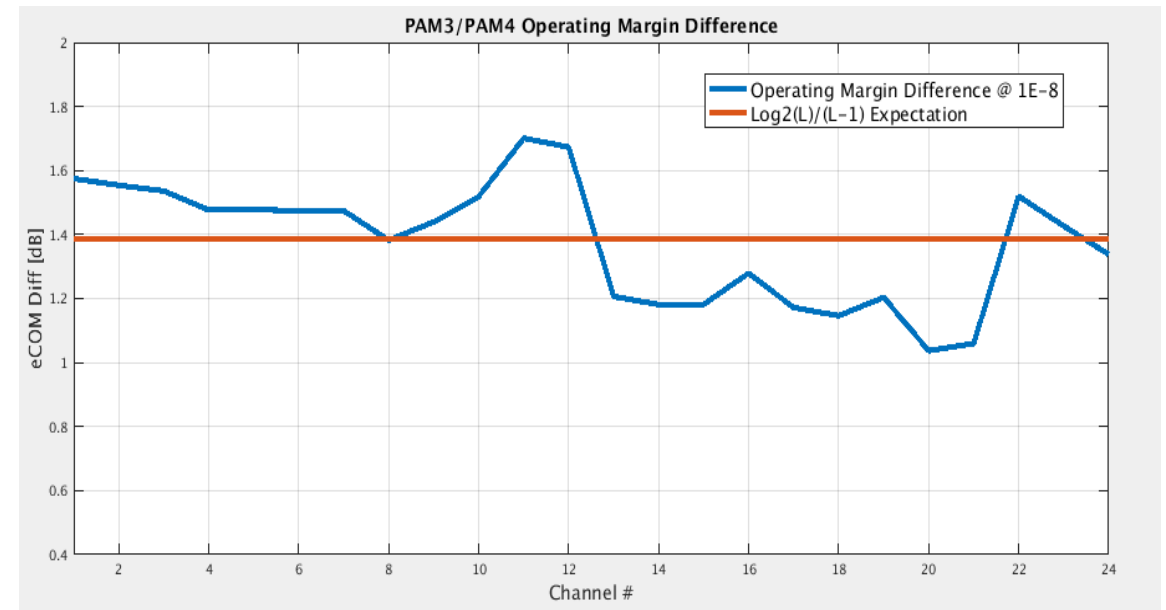

TX Circuit UDJ Background

- IEEE 50G Ethernet standard (802.3cd) reference:

- $J_{rms}=0.023UI$ (STD of the jitter PDF)
- $J_{3u}=0.115UI$ (Pk-Pk jitter including all but 1E-3 tail of the jitter PDF)

- Deriving the corresponding UDJ assuming SJ dominated model:

$$J_{rms}^2=(A_{pj}/\sqrt{2})^2+RJ^2$$

$$J_{3u}=2*A_{pj}+2*Q3*RJ \quad //Q=3.29 (Q(Q3)=0.5*1E-3)$$

$$\rightarrow A_{pj}=0.03UI \text{ peak}$$

- Deriving the corresponding UDJ assuming Dual-Dirac dominated model:

$$J_{rms}^2=A_{DD}^2+RJ^2$$

$$J_{3u}=2*A_{DD}+2*Q3*RJ \quad //Q=3.29 (Q(Q3)=0.5*1E-3)$$

$$\rightarrow A_{DD}=0.02UI \text{ peak}$$

- IEEE reference TX UDJ is at 0.02-0.03UI peak range (depends on the UDJ exact components), and therefore 0.025UI peak (0.05UI pk-pk) is assumed

SSC Residual Jitter Background

- Triangular SSC modulation test-case:

$$SSC_{Jitter_{pkpk}} = \frac{1}{T} \cdot \frac{\left(16[us] \cdot \frac{T \cdot SSC_{pkpk}}{2}\right)}{2} = \frac{16[us] \cdot SSC_{pkpk}[ppm] \cdot 10^{-6}}{4} = 12ns \quad (SSC_{pkpk} = 3000ppm)$$

- Sinusoidal SSC modulation test-case:

$$SSC_{Jitter_{pkpk}} = \frac{1}{T} \cdot 2 \cdot \frac{T \cdot SSC_{pkpk}[ppm] \cdot 10^{-6}}{2} \cdot \frac{1}{2 \cdot \pi \cdot 32e3[Hz]} = \frac{SSC_{pkpk}[ppm] \cdot 10^{-6}}{2 \cdot \pi \cdot 32e3[Hz]} = 15ns \quad (SSC_{pkpk} = 3000ppm)$$

Residual jitter assuming CDR jitter rejection of 91dB @ 32KHz ($\zeta=0.71$, $\omega_n=3.8E7$ r/s):

Triangle SSC profile: 12ns – 91dB = 0.34ps

Sinusoidal SSC profile: 15ns – 91dB = 0.42ps

→ 0.4ps pk-pk (0.01UI) is assumed

Correlated Errors: Networking Reference

- Correlated errors are observed in PAM4 optical links (based on field measurements)
- Correlated errors exist regardless of the DFE error propagation effects
- IEEE spec is defined as following:

For the 50GBASE-KR and 100GBASE-KR2 PHYs, in order to support the required frame loss ratio (see 1.4.275) of less than 6.2×10^{-10} for 64-octet frames with minimum interpacket gap, the PMD and the adjacent PMA are expected to detect bits from a compliant input signal at a BER lower than 2.4×10^{-4} assuming errors are sufficiently uncorrelated. This BER allocation enables a frame loss ratio lower than 10^{-10} after processing by the RS-FEC (Clause 134 or Clause 91) and the PCS (Clause 133 or Clause 82) if there are negligible errors due to other electrical interfaces (50GAUI-n or 100GAUI-n). If the PMD and PMA create errors that are not sufficiently uncorrelated, the BER is required to be lower as appropriate to maintain a frame loss ratio lower than 10^{-10} .

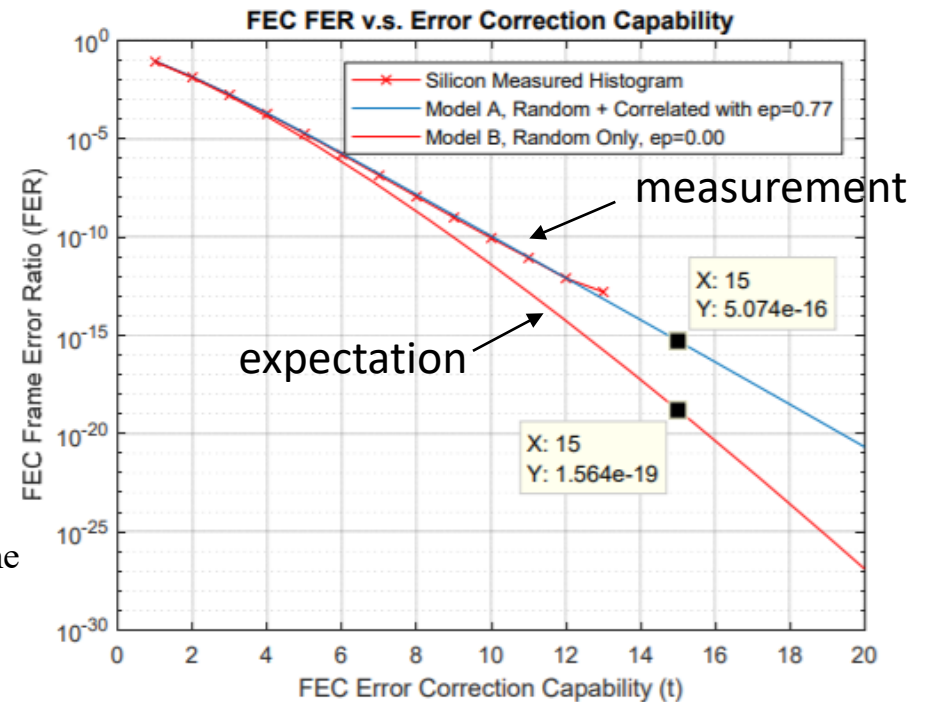

Source: IEEE 802.3ck/cd material