

Electrical Compliance Test Specification Linear Re-Driver Active Cable (LRD)

Date: November 10, 2022

Revision: 1.0

Copyright © 2023, USB Implementers Forum, Inc.

All rights reserved

THIS SPECIFICATION IS PROVIDED TO YOU "AS IS" WITH NO WARRANTIES WHATSOEVER, INCLUDING ANY WARRANTY OF MERCHANTABILITY, NON-INFRINGEMENT, OR FITNESS FOR ANY PARTICULAR PURPOSE. THE AUTHORS OF THIS SPECIFICATION DISCLAIM ALL LIABILITY, INCLUDING LIABILITY FOR INFRINGEMENT OF ANY PROPRIETARY RIGHTS, RELATING TO USE OR IMPLEMENTATION OF INFORMATION IN THIS SPECIFICATION. THE PROVISION OF THIS SPECIFICATION TO YOU DOES NOT PROVIDE YOU WITH ANY LICENSE, EXPRESS OR IMPLIED, BY ESTOPPEL OR OTHERWISE, TO ANY INTELLECTUAL PROPERTY RIGHTS.

USB Type-C®, USB-C® and USB4® are trademarks of the Universal Serial Bus Implementers Forum (USB-IF). Thunderbolt™ is a trademark of Intel Corporation. All product names are trademarks, registered trademarks, or service marks of their respective owners.

CONTENTS

1	INTRODUCTION	5
2	FREQUENCY DOMAIN TEST	6
3	TIME DOMAIN CABLE STAND – ALONE TEST	8
4	TIME DOMAIN CABLE OUTPUT EYE TEST	11
5	APPENDIX A – SCOPE CONFIGURATIONS	17
5.1	Scope BW Limit.....	17
6	APPENDIX B USB4 RECEIVER CALIBRATION	18
6.1	Receiver Test Setup.....	20
6.2	Receiver Stressed Eye Calibration	20
6.2.1	Stressed Electrical Signal for TP3' (Case 1):	21
6.2.2	Stressed Electrical Signal for TP3 (Case 2):	27
7	APPENDIX C – USB4 EQUALIZATION CALIBRATION	30
7.1	Gen 2 Configuration.....	30
7.2	Gen 3 Configuration.....	31
8	APPENDIX D – USB4 RX TP3 TRACE CALIBRATION	33
8.1	Gen2 Configuration.....	33
8.2	Gen3 Configuration.....	33
9	APPENDIX E – APPLYING DFE USB4 METHOD	34
10	APPENDIX F USB3.2 RECEIVER CALIBRATION	35
11	APPENDIX G – USB3.2 GEN2 REFERENCE EQUALIZATION FUNCTION	37
12	APPENDIX H – APPLYING DFE USB3.2 GEN2 METHOD	38
13	APPENDIX I – SWING CALIBRATION FOR TIME DOMAIN STAND - ALONE TEST	39
14	APPENDIX J –USB4/USB3.2 TEST EQUIPMENT	40
14.1	Overview	40
14.2	Test Equipment Requirements.....	40
14.2.1	Test Point Access Boards.....	40
14.2.2	Real Time Scopes.....	40
14.2.3	Pattern Generator	40
14.2.4	Network Analyzer.....	41
14.2.5	Signal Generator.....	41
14.2.6	Accessories	41
	USB3.2 Special requirements (in addition to listed above):	42
14.2.7	BERT (Bit Error Tester)	42
14.2.8	Real Time Scopes.....	42
15	APPENDIX K – LRD FUNCTIONAL SETUP	43
16	APPENDIX L – PRE-CERTIFICATION PHASE	44

Acronyms

Acronym	Definition
BER	Bit Error Rate
BW	Band Width
CDR	Clock Data Recovery
DUT	Device Under Testing
NVM	Non Volatile Memory
PJ	Periodic Jitter
SSC	Spread Spectrum Clock
TJ	Total Jitter
UI	Unit Interval
UJ	Uncorrelated Jitter
UDJ	Uncorrelated Deterministic Jitter
RJ	Random Jitter
ISI	Inter Symbol Interference
DDJ	Data dependent Jitter
PPM	Parts Per Million
PRBS	Pseudo Random Bit Sequence
IL	Insertion Loss

1 Introduction

This document contains the specification of procedures, tools and criteria for testing electrical compliance of Linear Re-Driver Active Cable according to the LRD Specification Version 0.89 (ECR in the Type-C base specification), USB3.2 Specification Version 1.0, USB4 Router Assembly Specification Version 1.0.

The following sections provide detailed information on the setup and testing of the LRD cable parameters. In the event of a discrepancy, the USB3.2, USB4, LRD Active Cable specifications prevail.

The compliance testing of a cable will be done based on the measurements from both time and frequency domains.

For all time domain spec items, the measured LRD based cable parameters will be compared to the worst-case passive cable supported in each technology (with nominal cable length of 1m for USB3.2, 2m for USB4-Gen2 and 0.8m for USB4-Gen3) measured in the exact same setup to reduce testing complexity.

General Note

A tested cable shall be measured for all pairs and in both directions (4 pairs, 2 directions → 8 combinations total).

All the details in this document are provided for one measurement which shall be repeated for all 8 combinations.

Measurement of each pair shall be provided in one folder.

folder name: < cable name >_< pair1/2/3/4 >_< direction1/2 >

(for instance: Intel_2m_cable_id003_pair2_direction1).

The files names inside this folder shall follow the naming convention defined in the different setups chapters.

Since the LRD based cable needs power, all setups shall also provide power to the cable Vconn pin.

2 Frequency domain test

Reference

Cable – LRD Specification 6.6.5.4.2

Requirement

LRD based active cable should be measured using VNA/ENA to extract S parameters.

Note:

All requirements shall be provided and defined as PASS/FAIL by Get_iPar Tool used for passive cable certification. See detailed user manual in the tool itself. The tool will be available in the USB-IF. The minimum version for the tool is Get_iPar_v0p91a.

The S parameters will be used to run COM and to calculate IMR and IRL.

Operating margin Receiver margin evaluation - LRD Specification 6.6.5.4.10

Channel Operating Margin (COM) $\geq 3dB$

Channel Operating Margin (COM) shall be calculated for cables supporting USB4 Gen3, for evaluating a reference receiver margin based on the cable measured S parameters.

IRL Integrated Return Loss - LRD Specification 6.6.5.4.8

The IRL limits for LRD cable are given by the functions in this table:

mode	IRL limit
USB3 – Gen2:	$IRL \leq 0.046 \cdot ILfitatNq^2 + 1.812 \cdot ILfitatNq - 8.784$
USB4 – Gen2:	$IRL \leq 0.046 \cdot ILfitatNq^2 + 1.812 \cdot ILfitatNq - 8.784$
USB4 – Gen3:	$if(-4dB \leq ILfit@Nq): IRL \leq -13dB$ $if(ILfit@Nq < -4dB): IRL \leq ILfit@Nq - 9$

IMR Integrated multi-reflection (integration of ILD -Insertion loss deviation) - LRD Specification 6.6.5.4.9

The IMR limits for LRD cable are given by the functions in this table:

mode	IMR limit
USB3 – Gen2:	$IMR \leq 0.126 \cdot ILfitatNq^2 + 3.024 \cdot ILfitatNq - 20.392$
USB4 – Gen2:	$IMR \leq 0.126 \cdot ILfitatNq^2 + 3.024 \cdot ILfitatNq - 20.392$
USB4 – Gen3:	$if(-4dB \leq ILfit@Nq): IMR \leq -29dB$ $if(ILfit@Nq < -4dB): IMR \leq 1.741 \cdot ILfit@Nq - 22.143$

Test Setup

Note: Before beginning any test or data acquisition, the Network Analyzer must be warmed, and calibrated.

See appendix J for test equipment requirements.

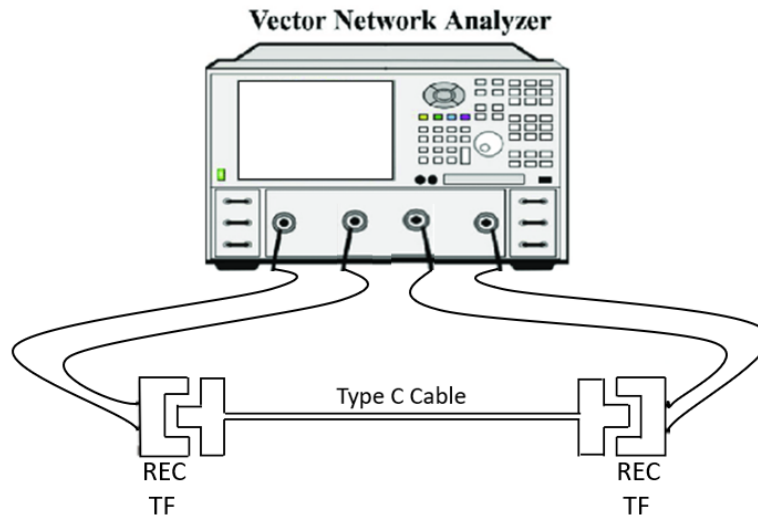

Figure 1. Frequency domain test setup

Test Method

1. Setup the Network Analyzer according to the following definitions:

- Frequency range of 10MHz to 20GHz (max frequency of 20GHz is the minimum required; 40GHz shall be used if VNA allows).
- Frequency step of 10MHz
- IF BW of 1KHz
- Power of 4dBm for LRD only (For passive cable the Power of 0dBm shall be used)
- Impedance 85ohm differential (42.5ohm single-ended)
- The measurements may be done with 16-, 12-, 8- or 4-port VNA.
8 or more VNA ports are recommended to minimize the manual work.

Note:

The setup should be de-embedded from the measurements to provide cable-only S parameters.

2. Calibrate the network analyzer using an auto calibration kit (ECAL).
3. Connect the setup according to the Figure 1.
4. Choose an appropriated passive cable (using USB Type-C 0.8m USB4 Gen3 supported, 2m USB4 Gen2 supported, 1m USB3.2 supported passive cables) to start with.
5. Save S4P file per pair.
Name: fd_4dbm<_optional name>.s4p
6. Repeat steps [5-6] with LRD DUT using the setup described in Appendix K.

Note:

The LRD DUT S-Parameters shall be used in the Get_iPar Tool.

The passive cable S-Parameters shall be used as reference for Time Domain cable stand - alone test, see section 3.

3 Time Domain cable stand – alone test

Reference

Cable – LRD Specification 6.6.5.4.2

Requirements

Note:

All requirements shall be provided and defined as PASS/FAIL by SW Tool. See detailed user manual in the Tool itself. The tool will be available in the USB-IF.

ILfit LRD Specification 6.6.5.4.4

Defining the ILfit mask for the cable response, the main intention is to keep the cable with LPF characteristic similar to the passive cable.

$$\begin{aligned} ILfitatNq[dB] + 1.5dB &< ILfitatDC[dB] < 0 \\ ILfitatNq[dB] &< ILfitatf1[dB] < ILfitatDC[dB] \\ USB\ 3.2: -6dB &< ILfitatNq[dB] < ILfitatDC[dB] - 1.5dB \\ USB4\ Gen2: -12dB &< ILfitatNq[dB] < ILfitatDC[dB] - 1.5dB \\ USB4\ Gen2: -7.5dB &< ILfitatNq[dB] < ILfitatDC[dB] - 1.5dB \\ ILfitatNq[dB] - 3dB &< ILfitatf2[dB] < ILfitatNq[dB] \\ ILfitatf2[dB] - 4dB &< ILfitatf3[dB] < ILfitatf2[dB] \end{aligned}$$

Max gain of the cable in the range of DC to fN

$$ILfitatfWB[dB] < 0$$

Output Noise Sigma_N LRD Specification 6.6.5.4.5 and 6.6.5.4.6

Standard deviation of the cable output noise. Combination of all noises beside the nonlinearity noise.

The limit of OUTPUT_NOISE is defined as function of the IL at Nyquist frequency. This allow a degree of freedom to the cable developer to trade between the cable's gain and noise.

The limit is defined as:

$$\sigma_{cable} [mV] \leq \sqrt{\frac{\sigma_1^2}{10^{\frac{H(fN)PC-H(fN)RC}{10}}} - \sigma_1^2} \cdot \frac{1}{a}$$

Sigma_E LRD Specification 6.6.5.4.7

Standard deviation of the Non-linearity noise measured in the cable output

$$\sigma_{Sigma_E} < 15\ mV$$

CM_NOISE LRD Specification 6.6.5.4.13

CM_NOISE is defined as the maximum peak value of the signal captured in the cable output with common setting to the scope $(p + n)/2$ and prbs15 data pattern.

$$CM_{NOISE} < 100\ mV_{pp}$$

Test Setup

The following figure shows the connection between BERT and Scope via Type C cable used for time domain cable stand-alone testing.

LRD based active cable should be measure in this setup to extract the additive noise in the cable output and the cable pulse response.

Note: Before beginning any test or data acquisition, the Oscilloscope must be warmed, and calibrated. For all tests the signal must be vertical tuned to be opened.

See appendix J for test equipment requirements.

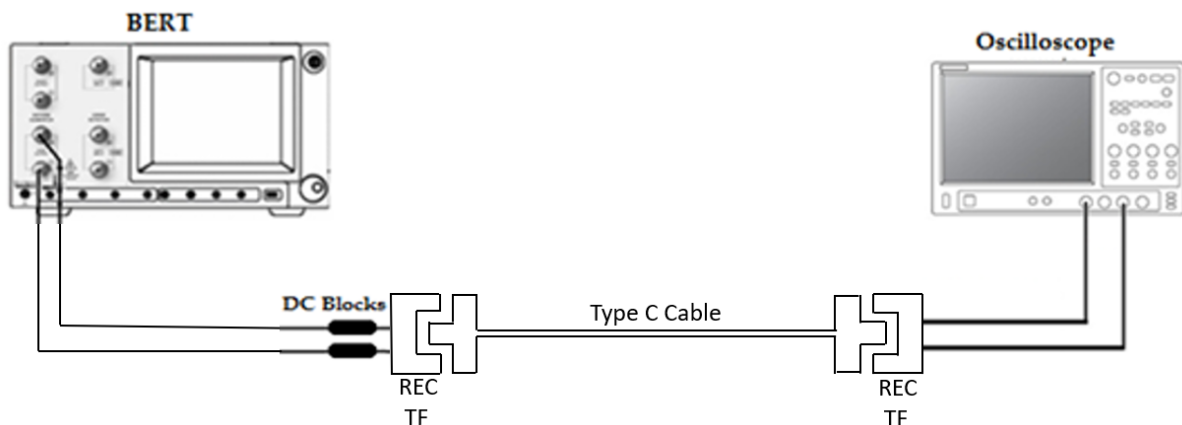

Figure 2. Time domain cable stand – alone test setup

Test Method

Note:

All measurements in this setup shall be done using following configurations:

- No TxFFE applied
- SSC turned OFF
- All jitter components turned OFF
- ACCM Common mode noise turned OFF

The scope configurations shall be as following:

- Sampling Rate $\geq 80\text{GSa/s}$
- The evaluated record length shall be not less than $20\mu\text{s}$ per channel.
- No CDR, no average and no interpolation to be used.
- Adjust vertical scale to fit signal into scope screen.
- Scope BW shall be as specified in Appendix A.

1. Connect the setup according to the Figure 2 - Time domain cable stand – alone test setup.
2. Choose supported USB4 / USB3.2 speed with an appropriated passive cable (using USB Type-C 0.8m USB4 Gen3 supported, 2m USB4 Gen2 supported, 1m USB3.2 supported passive cables).
3. Cable Gain, Non- Linearity Noise tests.
Configure the Generator as following:
 - PRBS15 pattern.
 - Swing 800mVp-p**Note:**
The swing shall be calibrated according to the Appendix I.
Capture the waveform on the scope and save as following:
 - a) Signal type: The differential signal (p - n)
Name: prbs15_min_swing<optional name>.bin
 - b) Signal type: The common signal (p + n)/2
Name: prbs15_cmn<optional name>.bin
4. Non- Linearity Noise test.
Configure the Generator as following:
 - PRBS15 pattern.
 - Swing - USB4: 1300mVp-p, USB3.2: 1200mVp-p**Note:**
The swing shall be calibrated according to the Appendix I.
Capture the waveform on the scope and save as following:
 - a) Signal type: The differential signal (p - n)
Name: prbs15_max_swing<optional name>.bin
5. Output Noise test.
Configure the Generator as following:
 - SQ512 pattern (256 `1's followed by 256 `0')
 - Swing 300mVp-p**Note:**
The swing shall be calibrated according to the Appendix I.

Capture the waveform on the scope and save as following:
 - a) Signal type: The differential signal (p - n)
Name: sq512<optional name>.bin
6. Repeat the measurements above [1-5] for all supported USB4 Gen2 and Gen3 / USB3.2 speeds.
7. Repeat steps [2-6] with LRD DUT using the setup described in Appendix K.

Note

The reference passive cable folder only shall include also the S-Parameters. See section 2 for details.

4 Time domain cable output eye test

Reference

Cable output eye mask – LRD Specification 6.6.5.4.11

Requirement

The optimal LRD cable eye shall meet these criteria - LRD Specification 6.6.5.4.11

$LRD\ cable\ eye\ area \geq Passive\ cable\ eye\ area$

AND

$LRD\ cable\ eye\ width > 0.9 * Passive\ cable\ eye\ width$

Note:

The maximum eye height is constraint by the spec item ILfitatWB that prevent active amplification over the entire frequency range.

Test Setup

The test setup shall be identical to the USB3.2 and USB4 calibrated receiver test which includes the worst-case passive cable and used to measure the eye at the cable output.

Note:

1. Before beginning any test or data acquisition, the Oscilloscope must be warmed, and calibrated. The cables used for measurement shall be de-embedded (4 port). For all tests the signal must be vertical tuned to be opened.
2. The postprocessing for USB4 Time domain cable output eye test setup will be done using USB4 SigTest instead of Oscilloscope starting from next LRD CTS revision.

See appendix J for test equipment requirements.

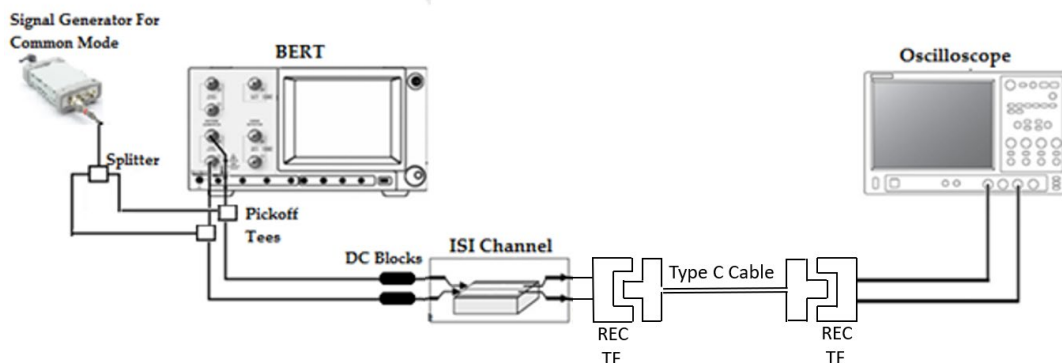

Figure 3. USB4 Time domain cable output eye test setup

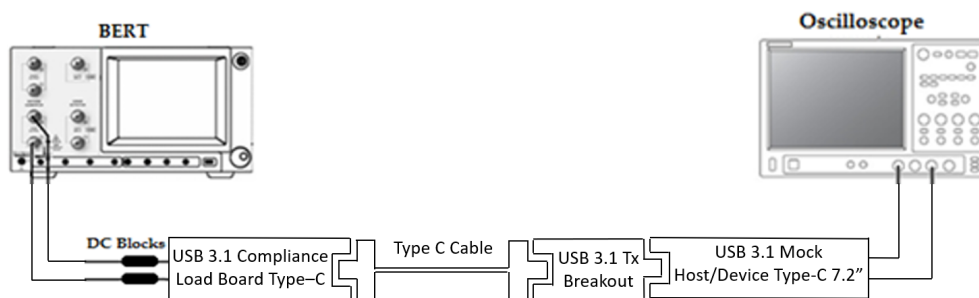

Figure 4. USB3.2 Time domain cable output eye test setup

Test Method

During the test, a reference CTLE, DFE and TXFFE settings shall be tuned according to the USB3.2 /USB4 spec for obtaining the optimal eye.

USB4 test method

1. Perform the receiver calibration according to the Appendix B (using USB Type-C 0.8m Gen3 supported and 2m Gen2 supported passive cables).
2. Connect the setup according to the Figure 3 - USB4 Time domain cable output eye test setup (using USB Type-C 0.8m Gen3 supported and 2m Gen2 supported passive cables).
3. Choose a supported USB4 speed to start with.
4. Recall Test Case 2 calibrated setup for PJ 100MHz that was saved in calibration section Appendix B.
5. Configure the Generator to preset 0
6. Measurement shall be done with a calibrated reference equalizer (CTLE and DFE) as described in Appendix C.
7. Measurement shall be done with a reference CDR modeled by a 2nd order PLL response which drives High-Pass-Filter (HPF) rejection mask with 3dB bandwidth at 5MHz and damping factor of 0.94; interpolation shall be applied for obtaining effective sample rate of 1280GSa/s (e.g. X16 interpolation for 80GSa/s hardware sampling rate). Scope BW shall be as specified in Appendix A.
8. Capture the waveform and process it with the oscilloscope:
 - Sampling Rate \geq 80GSa/s
 - Adjust vertical and horizontal scale to fit signal into scope screen.
 - Measured 1E6 UI
9. Capture Eye height and Eye width:
 - a. Eye height shall be at the "0" of the real time eye horizontal position. A Histogram shall be applied to the lower and upper section of the eye, with +/- 1% deviation in time axis in order to calculate the eye height. Use min value from upper histogram result and max value from lower histogram results. Eye height is the delta between them. See Figure 9 and Figure 10. If scope Eye Height measurement calculate with the same window, you can skip the above and use Eye Height scope measurement.
 - b. Capture 5 times (each time over new 1MUI record length) min value of both eye height (EH) and eye width (EW). Calculate Area by $EH * EW$.
 - c. Record EH and EW for each trial.
 - d. Average the 5 Area values.
10. Repeat the steps above [5-9] for all TXFFE presets in USB4 Spec Table 3-5.

11. Repeat the measurements above [2-10] for all supported USB4 Gen2 and Gen3 speeds.
12. Repeat steps [2-11] with LRD DUT.
13. The results shall be captured in the following form (for USB4 Gen2 and Gen3 speeds):

TXFFE Presets	Speed	Average passive cable optimal EH	Average passive cable optimal EW	Average passive cable optimal EA (Eye Area)	Average LRD DUT cable optimal EH	Average LRD DUT cable optimal EW	Average LRD DUT cable optimal EA (Eye Area)
0	Gen2						
...	Gen2						
15	Gen2						
				Max_Passive_Reference_Area=			Max_LRD_DUT_Reference_Area=
				Passive_Reference_Preset_with_max_Area=			LRD_DUT_Reference_Preset_with_max_Area=

Table 1. USB4 Time domain cable output eye test results template

14. **Pass Criteria:**

```
define EW_MARGIN_CONST 0.9
```

```
If Max_Passive_Reference_Area > Max_LRD_DUT_Reference_Area then Fail
```

```
Elseif
```

```
Average_passive_cable_optimal_EW(Passive_Reference_Preset_with_max_area)*EW_MARGIN_CONST > Average_LRD_DUT_cable_optimal_EW(LRD_DUT_Preset_with_max_area) then Fail
```

```
Else → Pass.
```

USB3.2 test method

Note:

All postprocessed measurements (Jitters, Eye parameters) shall be done using SigTest on the waveform saved by scope.

Capture the waveform and post process it with an appropriate software:

- Sampling Rate \geq 80GSa/s
- The evaluated record length shall be 200us per channel.
- Scope BW shall be as specified in Appendix A.

1. Perform the receiver calibration according to the Appendix F (using USB Type-C 1m Gen2 supported passive cable).
2. Connect the setup according to the Figure 4 – USB3.2 Time domain cable output eye test setup (using USB Type-C 1m Gen2 supported passive cable).
3. Configure the Generator to transmit USB3.2 Gen2 speed to start with.
4. Recall the calibrated setup for PJ 100MHz that was saved in calibration section Appendix F.
5. Use the fixed TxFFE calibrated preset according to the Appendix F.
6. Prepare the SigTest templates for 7 CTLEs using the Template "USB_3_10Gb_CP9_Rx_CAL_CTLE_N5dB.dat which was used for Rx calibration in the step#1 according to the following configurations:
 - a. Open the Template "USB_3_10Gb_CP9_Rx_CAL_CTLE_N5dB.dat and change the selected area according to the Table 2.

```
1 [common]
2
3 ; Enable the new SigTest Order of Operations flow
4 ; DFEOrderOfOperation = 0 Original SigTest DFE flow
5 ; DFEOrderOfOperation = 1 New SigTest DFE flow (NO CDR)
6 ; DFEOrderOfOperation = 2 New SigTest DFE flow (CDR w/ Peak Phase Detector)
7 ; DFEOrderOfOperation = 3 New SigTest DFE flow (CDR w/ ZFF)
8 DFEOrderOfOperation = 2
9
10 PhaseDetectorPrecisionBits = 8
11 PhaseDetectorProportionalBits = 1
12 PhaseDetectorIntegralBits = 4
13 DFEPrecisionBits = 10
14 DFEProportionalBits = 5
15 VrefPrecisionBits = 9
16 VrefProportionalBits = 5
17
18 ApplyMinMaxDFE = 1
19
20 ; Run CDR for full waveform and create variable UI recovered clock
21 SSCMode = 1
22
23 ; Number of iterations in the CDR/DFE loop
24 CDRIterations = 3000
25
26 ; Percentage of final iterations to use for averaging DFE & sample location
27 CDRFinalPercentNitters = 10
28
29 ; Apply all seven CTLE filters to
30 ; input waveform, keep the best one
31 DoCTLEFilter = 1
32 CTLEFilterCount = 1
33
34 ; set the number of UI to check in waveform
35 CTLEUICount = 100000
36
37 ; Set start and stop points of sample window
38 CTLESampleWindowStart = 0.4
39 CTLESampleWindowStop = 0.6
40
41 ; Optimisation criterion:
42 ; OPT_EYE_WIDTH = 0
43 ; OPT_EYE_HEIGHT = 1
44 ; OPT_EYE_AREA = 2
45 CTLEFilterOpt = 2
46
47 ; -5dB
48 CTLEFilterlAdc = 0.56234133
49 CTLEFilterlFs = 5.97160756e08
50 CTLEFilterlFp1 = 1.50e9
51 CTLEFilterlFp2 = 5.00e9
52
```

; -6dB CTLEFilter1Adc = 5.0118723e-01 CTLEFilter1Fz = 5.32220084e8 CTLEFilter1Fp1 = 1.50e9 CTLEFilter1Fp2 = 5.00e9	; -5dB CTLEFilter1Adc = 0.56234133 CTLEFilter1Fz = 5.97160756e08 CTLEFilter1Fp1 = 1.50e9 CTLEFilter1Fp2 = 5.00e9
--	--

; -4dB CTLEFilter1Adc = 0.63095734 CTLEFilter1Fz = 6.70025388e08 CTLEFilter1Fp1 = 1.50e9 CTLEFilter1Fp2 = 5.00e9	; -3dB CTLEFilter1Adc = 0.70794578 CTLEFilter1Fz = 7.51780850e08 CTLEFilter1Fp1 = 1.50e9 CTLEFilter1Fp2 = 5.00e9
--	--

; -2dB CTLEFilter1Adc = 0.79432823 CTLEFilter1Fz = 8.43511988e08 CTLEFilter1Fp1 = 1.50e9 CTLEFilter1Fp2 = 5.00e9	; -1dB CTLEFilter1Adc = 0.89125094 CTLEFilter1Fz = 9.46436017e08 CTLEFilter1Fp1 = 1.50e9 CTLEFilter1Fp2 = 5.00e9
--	--

; 0dB CTLEFilter1Adc = 1.00000000 CTLEFilter1Fz = 1.06191868e09 CTLEFilter1Fp1 = 1.50e9 CTLEFilter1Fp2 = 5.00e9

Table 2. USB3.2 CTLE configurations

b. Save the templates from the step #6a using the names according to the Table 3.

CTLE	SigTest Template Name
-6dB	USB_3_10Gb_CP9_Rx_CAL_CTLE_N6dB.dat
-5dB	USB_3_10Gb_CP9_Rx_CAL_CTLE_N5dB.dat
-4dB	USB_3_10Gb_CP9_Rx_CAL_CTLE_N4dB.dat
-3dB	USB_3_10Gb_CP9_Rx_CAL_CTLE_N3dB.dat
-2dB	USB_3_10Gb_CP9_Rx_CAL_CTLE_N2dB.dat
-1dB	USB_3_10Gb_CP9_Rx_CAL_CTLE_N1dB.dat
0dB	USB_3_10Gb_CP9_Rx_CAL_CTLE_N0dB.dat

Table 3. SigTest Template names

Note: SigTest will apply the automatic DFE (limited to max value 50mV).

7. Capture 5 waveforms on the scope for each one of the Templates prepared in the step #6 and process using SigTest.
 - a. Record the values of both eye height (EH) and eye width (EW) for each one of 5 trials.
 - b. Calculate Area by $EH * EW$ for each one of 5 trials.
 - c. Average the 5 Area values.
8. Repeat steps [2-7] with LRD DUT using the setup described in Appendix K.
9. The results shall be captured in the following form:

CTLE	Average passive cable optimal EH	Average passive cable optimal EW	Average passive cable optimal EA (Eye Area)	Average LRD DUT cable optimal EH	Average LRD DUT cable optimal EW	Average LRD DUT cable optimal EA (Eye Area)
0						
...						
6						
			Max_Passive_Reference_Area=			Max_LRD_DUT_Reference_Area=
			Passive_Reference_CTLE_with_max_Area=			LRD_DUT_Reference_CTLE_with_max_Area=

Table 4. USB3.2 Time domain cable output eye test results template

10. Pass Criteria:

```
define EW_MARGIN_CONST 0.9
```

```
If Max_Passive_Reference_Area > Max_LRD_DUT_Reference_Area then Fail
```

```
Elseif
```

```
Average_passive_cable_optimal_EW(Passive_Reference_CTLE_with_max_area)*
```

```
EW_MARGIN_CONST > Average_LRD_DUT_cable_optimal_EW(LRD_DUT_CTLE_with_max_area) then Fail
```

```
Else → Pass.
```

5 Appendix A – Scope Configurations

5.1 Scope BW Limit

- Gen 2 Configuration: Scope BW shall be 16 GHz.
- Gen 3 Configuration: Scope BW shall be 21 GHz.

6 Appendix B USB4 Receiver Calibration

Test Points definition

- Router Assembly receiver compliance testing is defined at the output of a “golden” plug fixture at the TP3’ reference point and at the output of a “golden” receptacle fixture at the TP3 reference point.
- TP3’- Reference measurement point located at the plug side of the Router Assembly RX input.
- TP3- Reference measurement point located at USB Type-C receptacle output on the far-end side of passive cable. Used as a reference point for passive installations. All the measurements at this point shall be done while applying reference equalization.
- All measurements shall be referenced to the TP3’/TP3 compliance point.
- Calibration shall be applied in cases where direct measurement is not feasible.
- All jitter measurements is done on the average frequency.

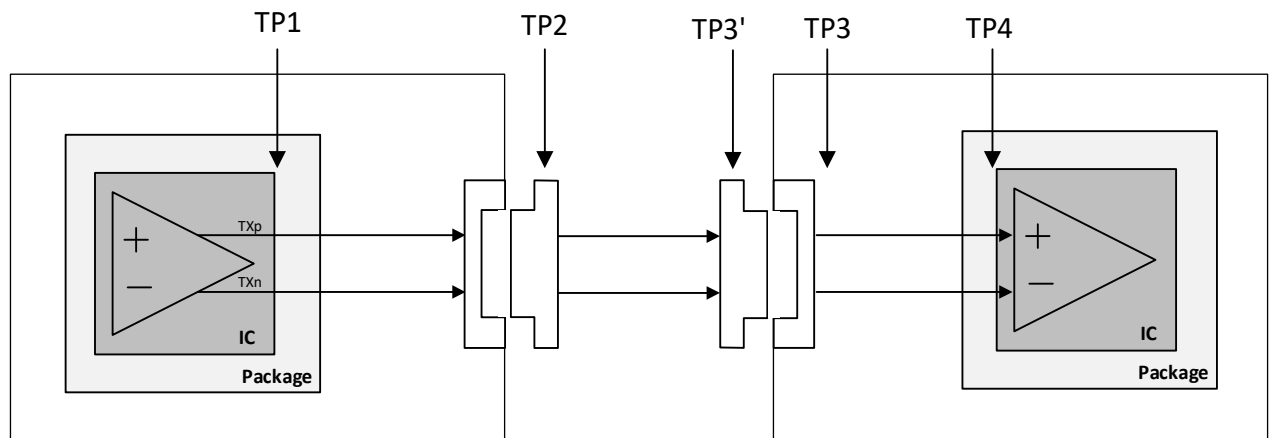
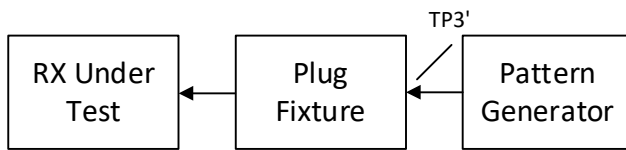

Figure 5. USB4 RX Compliance Points Definition

"Case1", which addresses installations with low Insertion-Loss
"Case2", which addresses installations with maximum Insertion-Loss

Case 1:



Case 2:

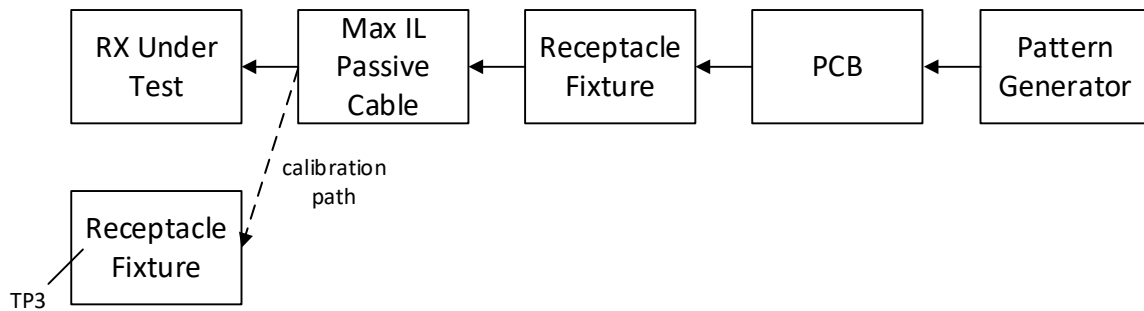

Figure 6. USB4 RX Tolerance Test Topologies

6.1 Receiver Test Setup

There are two physical setups required for Receiver testing, the Calibration Setup and the Test Setup.

Note: Before beginning any test or data acquisition, the Generator and Scope must be warmed, calibrated, and cables de-skewed.

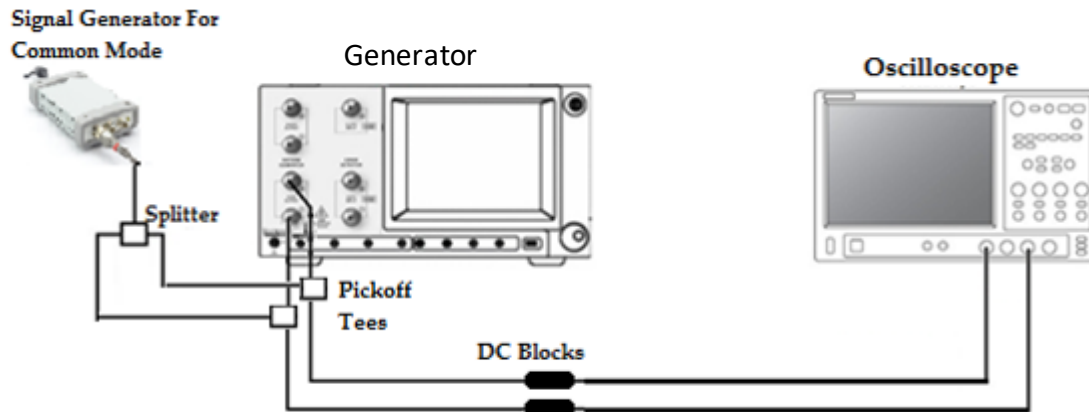

Figure 7. Receiver Calibration Setup – TP3'

6.2 Receiver Stressed Eye Calibration

The USB4 Specification outlines a minimum Receiver Eye Diagram which is measured at the USB Type-C connector at the plug side.

The following procedure describes how to calibrate the USB4 minimum Receiver Eye Diagram.

Connect the test setup to the Scope as in Figure 7 above.

1. Connect the DATA+/DATA- Output of the Generator to Pickoff Tee.
2. Use splitter at the output of the signal generator and connect the splitter output to the Pickoff Tee. The pickoff Tee shall be connected directly to the Generator, without any RF cable.
3. Use phase matched cables to connect the Pickoff Tee sum out to DC blocks. Add the DC block over the Pickoff Tee out pin directly.
4. Connect pair of phase matched cables from the DC blocks to the oscilloscope (maximum 1m length).

6.2.1 Stressed Electrical Signal for TP3' (Case 1):

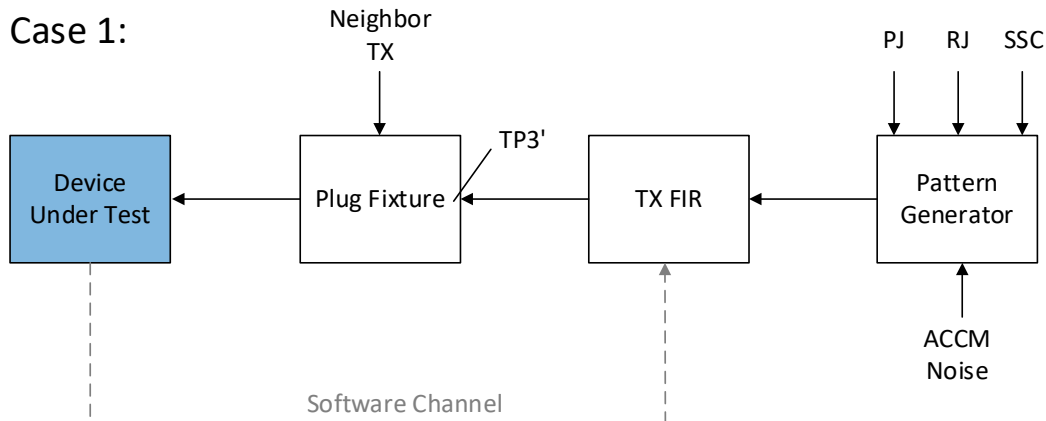

Set the SSC on the pattern generator to be:

- SSC with modulation wave shape triangle
- Modulation frequency for both Gen2 and Gen3 is 32KHz:
- Spread deviation from +300ppm up to -5300ppm

6.2.1.1 Data Dependent Jitter

6.2.1.1.1 Reference

USB4 Specification Table 3-5

6.2.1.1.2 Requirement

Data Dependent Jitter – Minimum possible DDJ

6.2.1.1.3 Test Method

1. Choose a supported USB4 speed to start with in the Generator.
2. Configure Generator transmit PRBS15 with SSC turned on and all jitter components turned off.
3. Configure Generator amplitude to fit into the Receiver Eye Mask.
4. Measurement shall be done with a reference CDR modeled by a 2nd order PLL response which drives High-Pass-Filter (HPF) rejection mask with 3dB bandwidth at 5MHz and damping factor of 0.94; no average and no interpolation to be used. Scope BW shall be as specified in Appendix A.
5. Capture the waveform and process it with the oscilloscope:
 - Sampling Rate $\geq 80\text{GSa/s}$
 - Evaluate 40Mpts per channel when using 80GSa/s. For higher sample rate use memory depth in the same ratio to 40Mpts. The evaluated record length shall be 500us per channel.
 - Pattern length -> Periodic
 - Jitter separation method shall be spectral.
 - Adjust vertical scale to fit signal into scope screen.
6. Configure the Generator to preset 0

7. Measure DDJ and Register it.
8. Repeat the measurement for all 16 presets, except preset 15 that are in Table 3-5.
9. Configure the Generator to the preset that provides the lowest DDJ.

6.2.1.2 AC Common Mode Measurements

6.2.1.2.1 Reference

AC_CM - USB4 Specification section 3.5.2

6.2.1.2.2 Requirement

AC common mode voltage - 100mVp-p

6.2.1.2.3 Test Method

1. Configure Generator transmit PRBS31 with SSC turned on and all jitter components turned off.
2. Configure Signal generator frequency to 400MHz, turn sinusoidal output on.
3. Capture the waveform and process it with the oscilloscope:
 - Sampling Rate $\geq 80\text{GSa/s}$
 - Evaluate 27Mpts per channel when using 80GSa/s. For higher sample rate use memory depth in the same ratio to 27Mpts. The evaluated record length shall be 337.5us per channel.
 - Adjust vertical scale to fit signal into scope screen.
 - No CDR, no average and no interpolation to be used.
 - Scope BW shall be as specified in Appendix A.
4. $V_{AC-CM} = (V_{TX-P} + V_{TX-N}) / 2$
5. Configure Signal generator amplitude to get V_{AC-CM} of 100mVp-p
6. Turn off the ACCM noise before calibrating the RJ.

6.2.1.3 Random Jitter

6.2.1.3.1 Reference

RJ - USB4 Specification Tables 3-11, 3-12

6.2.1.3.2 Requirement

Random Jitter - 0.14UIp-p Referenced to 1E-12 statistics.

6.2.1.3.3 Test Method

1. Turn Generator RJ generator on (PRBS15) with SSC on.
2. Measurement shall be done with a reference CDR modeled by a 2nd order PLL response which drives High-Pass-Filter (HPF) rejection mask with 3dB bandwidth at 5MHz and damping factor of 0.94; no average and no interpolation to be used. Scope BW shall be as specified in Appendix A.

3. Capture the waveform and process it with the oscilloscope:
 - Sampling Rate $\geq 80\text{GSa/s}$
 - Evaluate 40Mpts per channel when using 80GSa/s. For higher sample rate use memory depth in the same ratio to 40Mpts. The evaluated record length shall be 500us per channel.
 - Pattern length -> Periodic
 - Jitter separation method shall be spectral.
 - Adjust vertical scale to fit signal into scope screen.
 - Removing intrinsic scope noise and jitter is recommended.
 - Note, $RJp-p = RJrms * 14$
4. Tune RJ in the Generator to reach 0.14UIp-p over the oscilloscope
5. Turn off the RJ noise before calibrating the PJ

6.2.1.4 Periodic Jitter

6.2.1.4.1 Reference

PJ - USB4 Specification Tables 3-11, 3-12

6.2.1.4.2 Requirement

Periodic Jitter - 0.17UIp-p.

6.2.1.4.3 Test Method

1. Turn Generator sinusoidal jitter (PJ) frequency to 100MHz generator on (PRBS15) with SSC on.
2. Measurement shall be done with a reference CDR modeled by a 2nd order PLL response which drives High-Pass-Filter (HPF) rejection mask with 3dB bandwidth at 5MHz and damping factor of 0.94; no average and no interpolation to be used. Scope BW shall be as specified in Appendix A.
3. Capture the waveform and process it with the oscilloscope:
 - Sampling Rate $\geq 80\text{GSa/s}$
 - Evaluate 40Mpts per channel when using 80GSa/s. For higher sample rate use memory depth in the same ratio to 40Mpts. The evaluated record length shall be 500us per channel.
 - Pattern length -> Periodic
 - Jitter separation method shall be spectral.
 - Adjust vertical scale to fit signal into scope screen.
 - Removing intrinsic scope noise and jitter is recommended.
4. Tune PJ in the Generator to reach 0.17UIp-p over the oscilloscope (PJp-p).

6.2.1.5 Total Jitter

6.2.1.5.1 Reference

TJ - USB4 Specification Tables 3-11, 3-12

6.2.1.5.2 Requirement

Total Jitter - $0.35UI_{p-p}$ for Gen2, $0.38UI_{p-p}$ for Gen3, Referenced to BER = $1E-12$ statistics.

6.2.1.5.3 Test Method

1. Configure Generator transmit PRBS15 with SSC turned on and all jitter components turned on including the ACCM noise.
2. Measurement shall be done with a reference CDR modeled by a 2nd order PLL response which drives High-Pass-Filter (HPF) rejection mask with 3dB bandwidth at 5MHz and damping factor of 0.94; no average and no interpolation to be used. Scope BW shall be as specified in Appendix A.
3. Capture the waveform and process it with the oscilloscope:
 - Sampling Rate $\geq 80GSa/s$
 - Evaluate 40Mpts per channel when using 80GSa/s. For higher sample rate use memory depth in the same ratio to 40Mpts. The evaluated record length shall be 500us per channel.
 - Pattern length -> Periodic
 - Jitter separation method shall be spectral.
 - Adjust vertical scale to fit signal into scope screen.
 - Referenced to $1E-12$ statistics.
 - Removing intrinsic scope noise and jitter is recommended.
4. Verify TJ of $0.35 \pm 0.0125UI_{p-p}$ for Gen2 or $0.38 \pm 0.025UI_{p-p}$ for Gen3, if not, tune the total jitter by adjusting the PJ component for frequency of 100MHz.

6.2.1.6 Input Eye Diagram

6.2.1.6.1 Reference

USB4 Specification Tables 3-11, 3-12

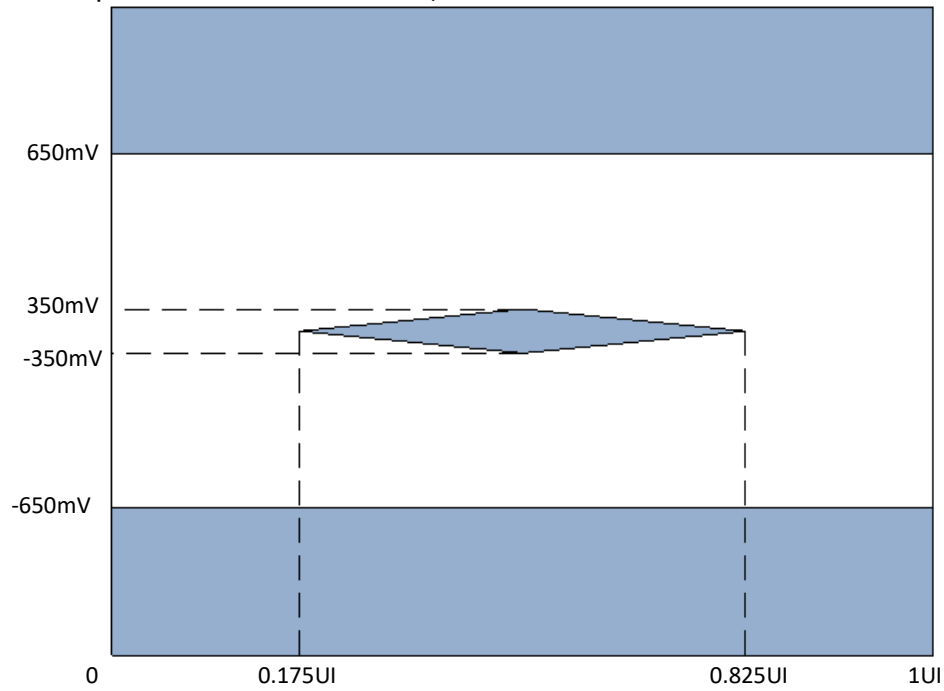

Router Assembly Gen2 Input Eye Notation

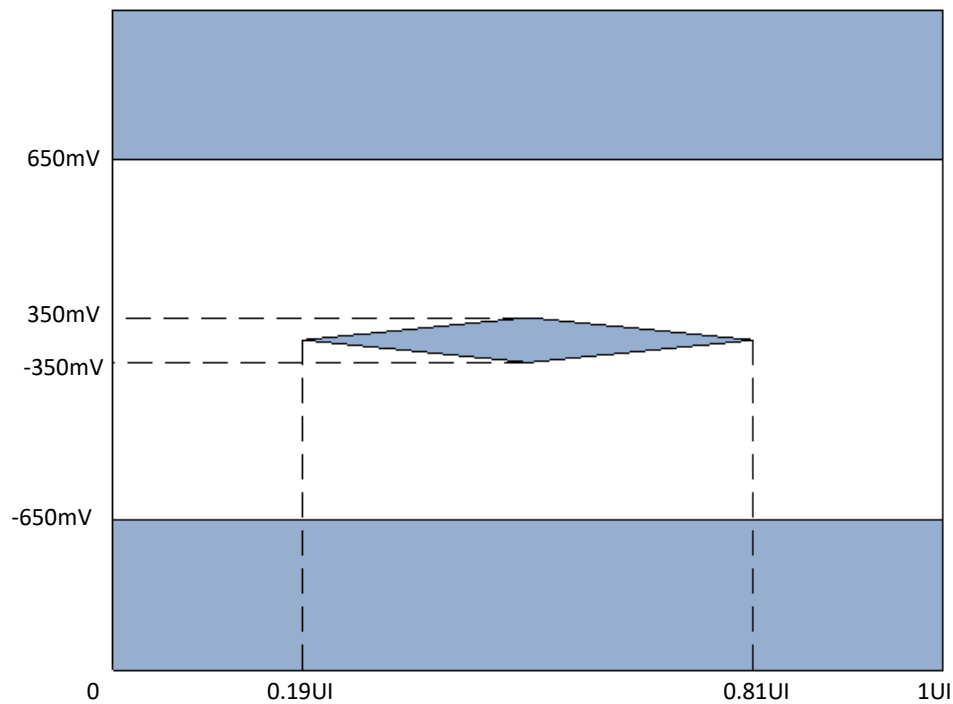

Router Assembly Gen3 Input Eye Notation

6.2.1.6.2 Requirement

Inner Eye height of 700mVp-p

6.2.1.6.3 Test Method

1. Configure Generator transmit PRBS31 with SSC turned on and all jitter components turned on including the ACCM noise.
2. Measurement shall be done with a reference CDR modeled by a 2nd order PLL response which drives High-Pass-Filter (HPF) rejection mask with 3dB bandwidth at 5MHz and damping factor of 0.94; interpolation shall be applied for obtaining effective sample rate of 1280GSa/s (e.g. X16 interpolation for 80GSa/s hardware sampling rate). Scope BW shall be as specified in Appendix A.
3. Capture the waveform and process it with the oscilloscope:
 - Sampling Rate \geq 80GSa/s
 - Adjust vertical and horizontal scale to fit signal into scope screen.
 - Measured 1E6 UI
4. Compare the data eye to the TP3' eye diagram mask:
 - If any part of the waveform hits the mask or if the eye is not minimal, Tune the Generator amplitude.
5. If Amplitude tune was needed, check all jitter and noise components again.
6. Save setup for the chosen speed TP3', min eye as **Test Case 1**.
7. Repeat the calibration sections 6.2.1.1 to 6.2.1.6 above for all supported USB4 Gen2 and Gen3 speeds.

6.2.2 Stressed Electrical Signal for TP3 (Case 2):

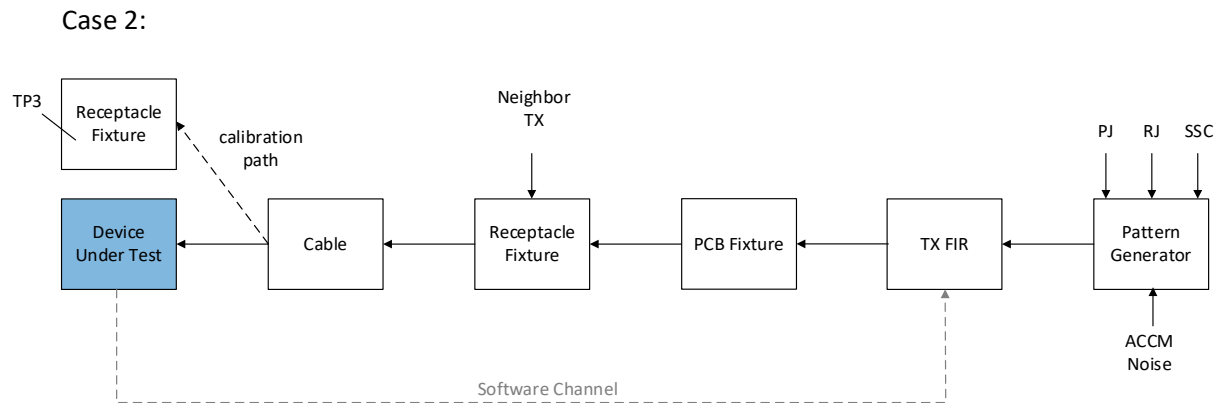

- The trace added shall be calibrated according to Appendix C.
- Cables connecting from the last receptacle to the scope shall be de-embedded. The length of the cable shall be maximum 1m.
- TP3 Calibration start point is TP3' test setup that was calibrated for **Test Case 1**.

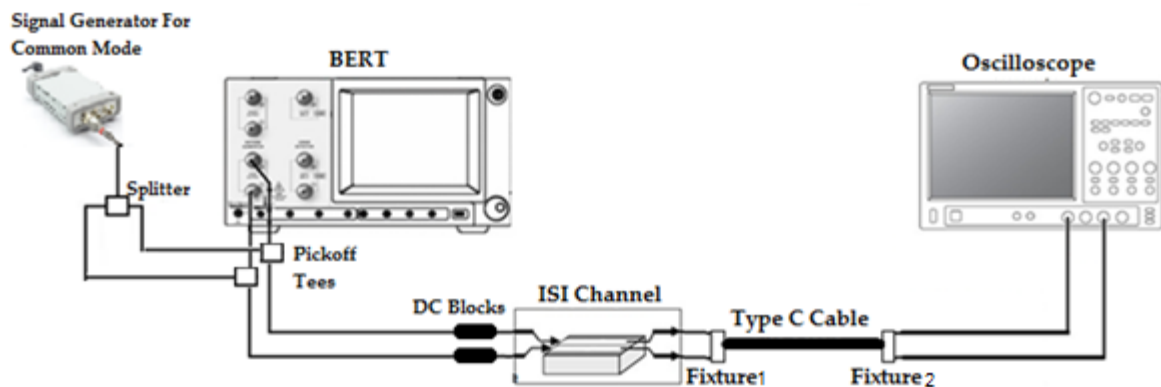

Figure 8. Receiver Calibration Setup – TP3

Note:

8. The Pickoff Tee shall be connected directly to the Generator out. The DC block shall be connected to the Pickoff Tee directly.
9. As there is no reliable solution for Total Jitter measurements at TP3 in the market, calibration is done referring to Eye measurements only.

6.2.2.1 Input Eye Diagram

6.2.2.1.1 Reference

USB4 Specification Tables 3-11, 3-12

6.2.2.1.2 Requirement

As there is no reliable solution for Total Jitter measurements at TP3 in the market, calibration is done referring to Eye measurements only:

Inner eye height within $120 \pm 10\text{mV}$ diff p-p for Gen2, $98 \pm 10\text{mV}$ diff p-p for Gen3

Eye width within $0.58 \pm 0.025\text{UI}$ p-p for Gen2, $0.54 \pm 0.05\text{UI}$ p-p for Gen3

6.2.2.1.3 Test Method

10. Choose a supported USB4 speed to start with.
11. Recall Test Case 1 calibrated setup that was saved in section [6.2.1.6.3](#) for PJ 100MHz.
12. Configure Generator transmit PRBS31 with SSC turned on and all jitter components turned on including the ACCM noise (as tuned for TP3').
13. Configure the Generator to preset 0
14. Measurement shall be done with a calibrated reference equalizer (CTLE and DFE) as described in Appendix B.
15. Measurement shall be done with a reference CDR modeled by a 2nd order PLL response which drives High-Pass-Filter (HPF) rejection mask with 3dB bandwidth at 5MHz and damping factor of 0.94; interpolation shall be applied for obtaining effective sample rate of 1280GSa/s (e.g. X16 interpolation for 80GSa/s hardware sampling rate). Scope BW shall be as specified in Appendix A.
16. Capture the waveform and process it with the oscilloscope:
 - Sampling Rate $\geq 80\text{GSa/s}$
 - Adjust vertical and horizontal scale to fit signal into scope screen.
 - Measured $1\text{E}6\text{ UI}$
17. Capture Eye height and Eye width:
 - e. Eye height shall be at the "0" of the real time eye horizontal position. A Histogram shall be applied to the lower and upper section of the eye, with +/- 1% deviation in time axis in order to calculate the eye height. Use min value from upper histogram result and max value from lower histogram results. Eye height is the delta between them. See Figure 9 and Figure 10. If scope Eye Height measurement calculate with the same window, you can skip the above and use Eye Height scope measurement.
 - f. Eye Height and Eye Width measurements shall be executed 5 times and the median measurement shall be used.

- If needed, tune the Eye height to be $120 \pm 10\text{mV}$ diff p-p for Gen2 and $98 \pm 10\text{mV}$ diff p-p for Gen3 by adjusting the Generator amplitude
- If needed, tune the Eye width to $0.58 \pm 0.025\text{UIp-p}$ for Gen2, $0.54 \pm 0.05\text{UIp-p}$ for Gen3 by adjusting the PJ component for frequency of 100MHz

18. Save **Test Case 2**

19. Repeat the calibration above for all supported USB4 Gen2 and Gen3 speeds.

7 Appendix C – USB4 Equalization Calibration

When testing at TP3, a reference equalization must be applied on the Oscilloscope. The reference receiver equalization function is comprised of parametric Continuous-Time-Linear-Equalizer (CTLE) and Decision-Feedback-Equalizer (DFE), as described in USB4 Specification section 3.3.4.1 and Section 3.3.4.2 respectively. A measurement that is referenced to TP3 shall use the best equalization parameters so that the calculated eye-diagram is optimized.

7.1 Gen 2 Configuration

The following equation describes the frequency response for USB4 reference CTLE that shall be used with the following parameters:

$$H(s) = 1.41 \cdot \omega_{p2} \cdot \frac{s + \frac{A_{DC}}{1.41} \cdot \omega_{p1}}{(s + \omega_{p1}) \cdot (s + \omega_{p2})}$$

- *AC Gain* = 1.41
 - $Wp1 = 2 * \pi * 1.5G \frac{rad}{sec}$ $Wp2 = 2 * \pi * 5G \frac{rad}{sec}$
 - ADC is the DC gain, Ten different CTLE configurations shall be applied such that ADC is one of $\{10^{\frac{-x}{20}} : x = 0 \div 9[dB]\}$ and shall be calibrated as follows:
 1. Configure DUT transmitter to output PRBS31 on all lanes with SSC turned on.
 2. Chose ADC for x=0
 3. Apply automatic DFE with max of 50mV. Gain shall be 1 at all time. Apply automatic DFE delay.
 4. Measurement shall be done with a reference CDR modeled by a 2nd order PLL response which drives High-Pass-Filter (HPF) rejection mask with 3dB bandwidth at 5MHz and damping factor of 0.94; interpolation shall be applied for obtaining effective sample rate of 1280GSa/s (e.g. X16 interpolation for 80GSa/s hardware sampling rate). Scope BW shall be as specified in Appendix A.
 - 5. Capture the waveform and process it with the oscilloscope:
 - a. Sampling Rate $\geq 80GSa/s$
 - b. Adjust vertical and horizontal scale to fit signal into scope screen.
 - c. Measured 1E6 UI
 - 6. Eye height shall be at the "0" of the real time eye horizontal position. A Histogram shall be applied to the lower and upper section of the eye, with +/- 1% deviation in time axis in order to calculate the eye height. Use min value from upper histogram result and max value from lower histogram results. Eye height is the delta between them. See Figure 9 and Figure 10.
 - 7. Capture 5 times (each time over new 1MUI record length) min value of both eye height (EH) and eye width (EW). Calculate Area by EH * EW.
 - 8. Average the 5 Area values.
 - 9. Start over from step #2 with x=x+1 and till x=9.
- The chosen ADC value including DFE tap value shall be the one that gives the maximal Area.
 - If there are two ADC values including DFE tap with the same area, choose the one with the greater eye height.

7.2 Gen 3 Configuration

The following equation describes the frequency response for USB4 reference CTLE that shall be used with the following parameters:

$$H(s) = 1.41 \cdot \omega_{p2} \cdot \frac{s + \frac{A_{DC}}{1.41} \cdot \omega_{p1}}{(s + \omega_{p1}) \cdot (s + \omega_{p2})}$$

- AC Gain: 1.41
- $\omega_{p1} = 2 * \pi * 5G \frac{rad}{sec}$ $\omega_{p2} = 2 * \pi * 10G \frac{rad}{sec}$
- ADC is the DC gain, Ten different CTLE configurations shall be applied such that ADC is one of $\{10^{\frac{-x}{20}} : x = 0 \div 9[dB]\}$ and shall be calibrated as follows:
 1. Configure DUT transmitter to output PRBS31 on all lanes with SSC turned on.
 2. Chose ADC for x=0
 3. Apply automatic DFE with max of 50mV. Gain shall be 1 at all time. Apply automatic DFE delay.
 4. Measurement shall be done with a reference CDR modeled by a 2nd order PLL response which drives High-Pass-Filter (HPF) rejection mask with 3dB bandwidth at 5MHz and damping factor of 0.94; interpolation shall be applied for obtaining effective sample rate of 1280GSa/s (e.g. X16 interpolation for 80GSa/s hardware sampling rate). Scope BW shall be as specified in Appendix A.
 5. Capture the waveform and process it with the oscilloscope:
 - a. Sampling Rate $\geq 80GSa/s$
 - b. Adjust vertical and horizontal scale to fit signal into scope screen.
 - c. Measured 1E6 UI
 6. Eye height shall be at the "0" of the real time eye horizontal position. A Histogram shall be applied to the lower and upper section of the eye, with +/- 1% deviation in time axis in order to calculate the eye height. Use min value from upper histogram result and max value from lower histogram results. Eye height is the delta between them. See Figure 9 and Figure 10.
 7. Capture 5 times (each time over new 1MUI record length) min value of both eye height (EH) and eye width (EW). Calculate Area by EH * EW.
 8. Average the 5 Area values.
 9. Start over from step #2 with x=x+1 and till x=9.
- The chosen ADC value including DFE tap value shall be the one that gives the maximal Area.
- If there are two ADC values including DFE tap with the same area, choose the one with the greater eye height.

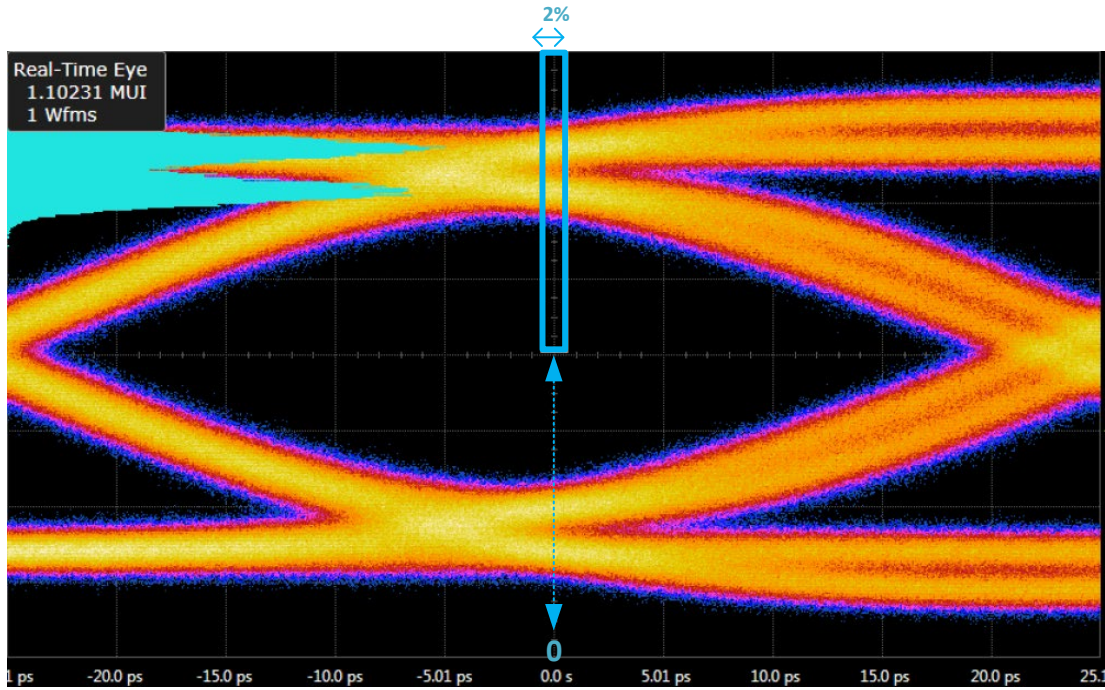

Figure 9. USB4 RX TP3 Eye Height upper location measurement

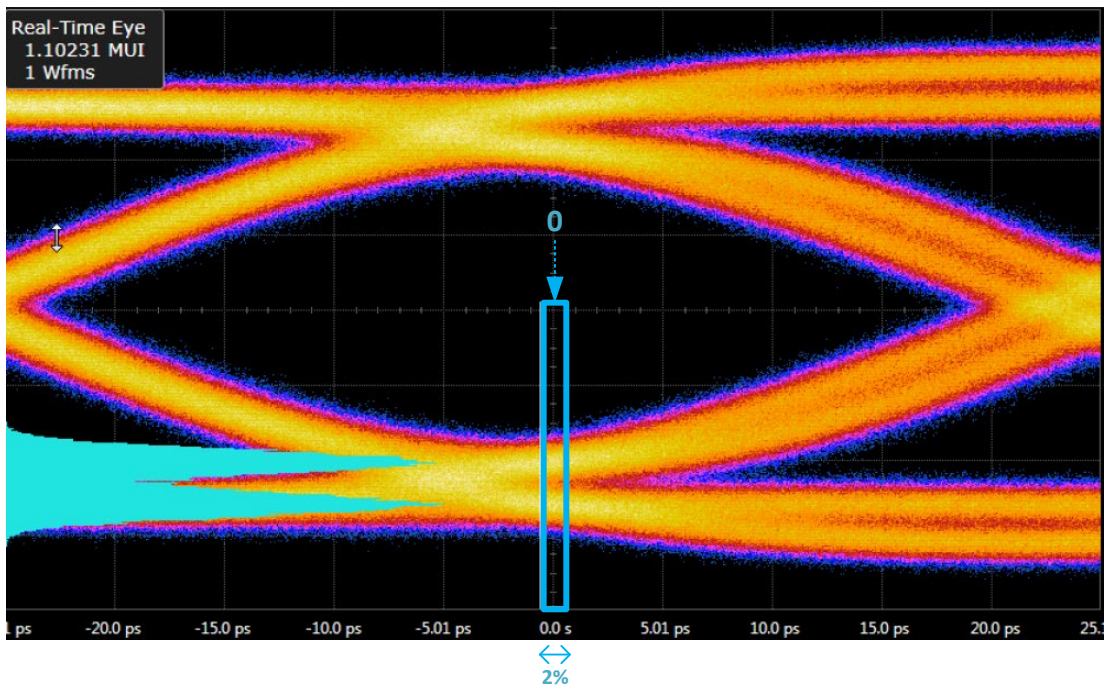

Figure 10. USB4 RX TP3 Eye Height lower location measurement

8 Appendix D – USB4 RX TP3 Trace Calibration

8.1 Gen2 Configuration

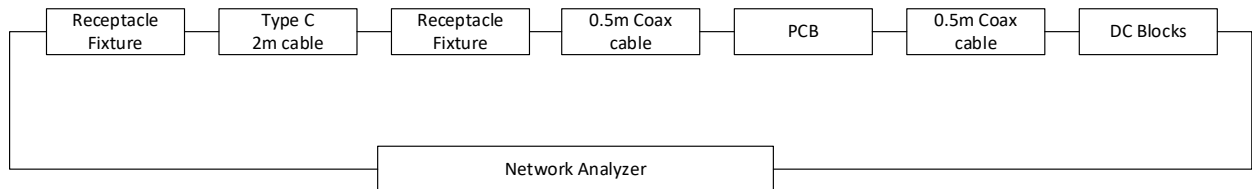

Figure 11. USB4 RX TP3 Trace Calibration Setup for Gen2

- The trace added shall be combined from a DDJ (PCB) and a USB Type-C 2m cable.
- The USB Type-C 2m cable insertion loss with the fixtures shall be $13 \pm 0.5\text{dB}$ at 5GHz and the total channel insertion loss shall be 18 to 19 dB at 5GHz for the entire channel (after the pickoff tees till the fixture, with the DC blocks).
- IL shall be dominated by the PCB and the 2m passive cable, the length of the RF cable shall be short as possible and, in any case, no more than 1m.
- All 2 lanes shall meet the above requirement.
- The chosen lane used for RX calibration shall be the lane with minimum IL (minimum of IL absolute value).

8.2 Gen3 Configuration

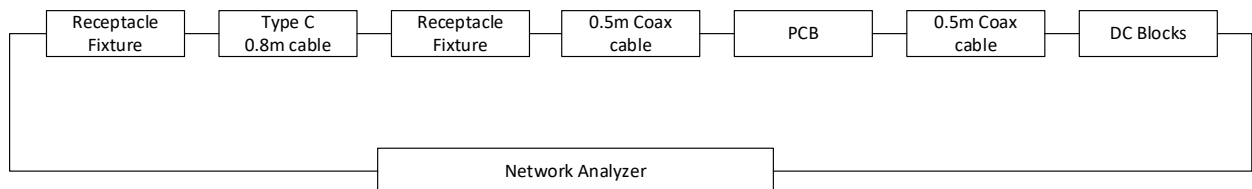
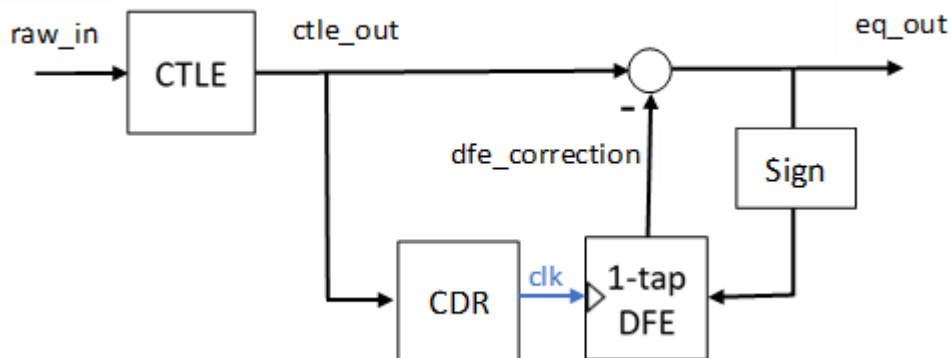

Figure 12. USB4 RX TP3 Trace Calibration Setup for Gen3

- The trace added shall be combined from a DDJ (PCB) and a USB Type-C 0.8m cable.
- The USB Type-C 0.8m cable insertion loss with the fixtures shall be $10.5 \pm 0.5\text{dB}$ at 10GHz and the total channel insertion loss shall be 16 to 17 dB at 10GHz for the entire channel (after the pickoff tees till the fixture, with the DC blocks).
- IL shall be dominated by the PCB and the 0.8m passive cable, the length of the RF cable shall be short as possible and, in any case, no more than 1m.
- All 2 lanes shall meet the above requirement.
- The chosen lane used for RX calibration shall be the lane with minimum IL (minimum of IL absolute value).

9 Appendix E – Applying DFE USB4 method

USB4 eye measurements at TP3 shall be performed using reference RX equalization function comprised of CTLE and DFE, as described in figure below. The eye shall be characterized after convolving the raw input signal with the CTLE function and subtracting the DFE correction implemented as constant voltage timed by the CDR clock aligned to the CTLE output. The DFE correction extends as a constant voltage from the mid-point between the UI clock and the previous clock to the mid-point between the UI clock and the next clock. In this way, the DFE correction is applied half a UI before the data sampling and changes again half a UI after the data sampling.



Waveforms example:

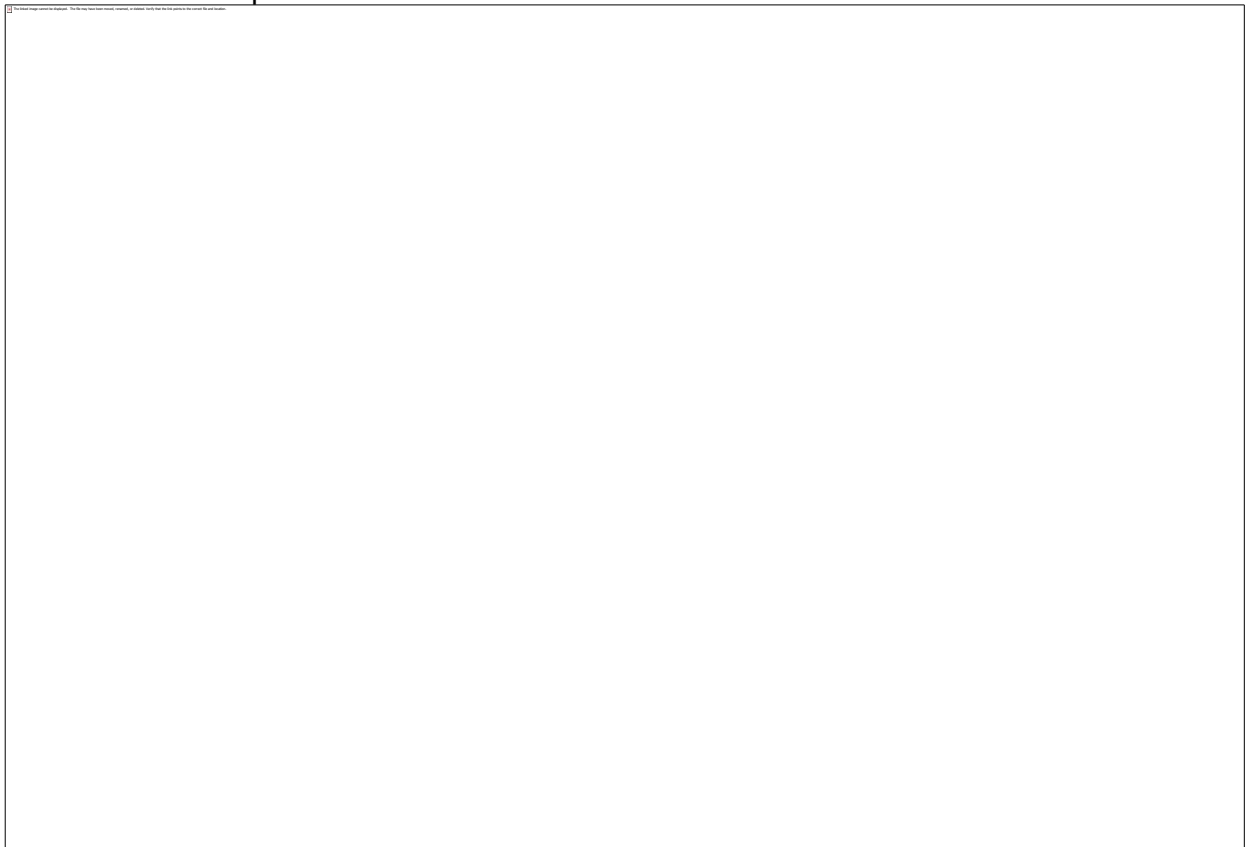

10 Appendix F USB3.2 Receiver Calibration

Note:

All postprocessed measurements (Jitters, Eye parameters) shall be done using SigTest on the waveform saved by scope.

Capture the waveform and post process it with an appropriate software:

- Sampling Rate $\geq 80\text{GSa/s}$
- The evaluated record length shall be 200us per channel.
- Scope BW shall be as specified in Appendix A.

1. The test runs in the Polling Loopback substate and performs the following steps.
 - a) Calibrate swing and de-emphasis without the test channel. Connect the end of the SMA cables that will connect to the SMAs on the test fixture (as directly as possible) to a real time oscilloscope and the other end to the test equipment generator.
 - b) Have the test equipment transmit a pattern with 64 ones followed by 64 zeros followed by 128 bits of a 1010 clock pattern at 10 GT/s.
 - c) Measure the transmitted signal on the oscilloscope and adjust the post cursor de-emphasis and swing of the generator until the low frequency and high frequency portions of the signal have an equal differential amplitude of 800 mV peak to peak.
 - d) Calibrate the measured TX EQ to 2.2 +/- .1 dB fixed preshoot
 - e) Calibrate the TX EQ de-emphasis settings for -1.0 +/- .1 dB, -3.1 +/- 1 dB, and -5.0 +/- .1 dB

Note: The signal source must support full bit de-emphasis.

2. Calibrate Rj (1.0 +0/- .1 ps RMS) with clock pattern (CP10). Calibrate after applying the JTF. The reference equalizer is not used for this Rj calibration. SSC is off and all other jitter sources are on but set to zero.
3. Calibrate Sj (17.0 ps +0/-10% at 100 MHz) with CP9. Calibrate without reference receiver equalization. SSC is off and all other jitter sources are on but set to zero. Calibration is done by testing measured maximum peak to peak jitter without extrapolation (measured TJ) without Sj and then adding Sj until measured maximum peak to peak jitter without extrapolation (measured Tj) increased by 17 ps. A 75 KHz critically damped high pass filter with 40 dB/decade roll-off is used during Sj calibration instead of the standard JTF.
4. Connect the calibration channel to the signal source using the shortest compliance load board (5.6").
5. Measure eye height with CP9 at a BER E-6 using the calibrated Sj and Rj values with SSC enabled. The eye height is measured after applying the JTF, the reference CTLE curve fixed to a DC gain of -5 dB, and DFE.

6. Change the compliance load board to the mid-length (7.1") and repeat the eye height measurement.
7. Change the compliance load board to the longest (8.1") and repeat the eye height measurement.
8. Select the compliance load board that yields the eye height measurement closest to 70 mV and use this compliance load board for the remaining calibration and testing.
 - a) In case the eye height measurement is higher than 75mV then replace the Mock Host/Device fixture to the 8.7" and repeat steps [4-8].
 - b) In case the eye height measurement is higher than 75mV then replace the Mock Host/Device fixture to the 9.7" and repeat steps [4-8].

Note: In case the eye height measurement is higher than 75mV then check the amplitude calibration and the physical setup.

9. Adjust the de-emphasis from 1 dB to 5 dB to adjust the eye width with a target of $48 +2/-0$ ps. The width is measured after applying JTF, the reference equalizer CTLE curve fixed to a DC gain of -5 dB, and DFE. SSC is still enabled for this step.
10. If the width target was not met in step 10 then:
 - a) If the width is too big then add a second S_j tone at 87 MHz and adjust until the width target is met.
 - b) If the width is too small, then reduce the 100 MHz S_j tone until the width target is met.

Note: If the adjustment in step 10a or 10b is bigger than 5 ps then there is likely a problem with the fixtures or set-up.

11. Adjust the signal source amplitude to provide 70 mV $+5/-0$ mV of eye height with calibration channel.

Note: Amplitude should be calibrated to be as close to the minimum value as possible without going under the minimum.

12. Save the calibrated Generator setup for SJ 100MHz.

11 Appendix G – USB3.2 Gen2 Reference Equalization Function

Equation (11.1) describes the frequency response for the Gen 2 reference continuous time linear equalizer (CTLE) that is used for compliance testing.

$$(11.1)H(s) = A_{AC}\omega_{p2} \cdot \frac{s + \frac{A_{DC}}{A_{AC}} \cdot \omega_{p1}}{(s + \omega_{p1}) \cdot (s + \omega_{p2})}$$

Where A_{AC} is the high frequency peak gain

A_{DC} is the DC gain

$\omega_{p1} = 2\pi f_{p1}$ is the first pole frequency

$\omega_{p2} = 2\pi f_{p2}$ is the second pole frequency

Figure 13 is a plot of the Compliance EQ transfer functions with the values for each of the input parameters.

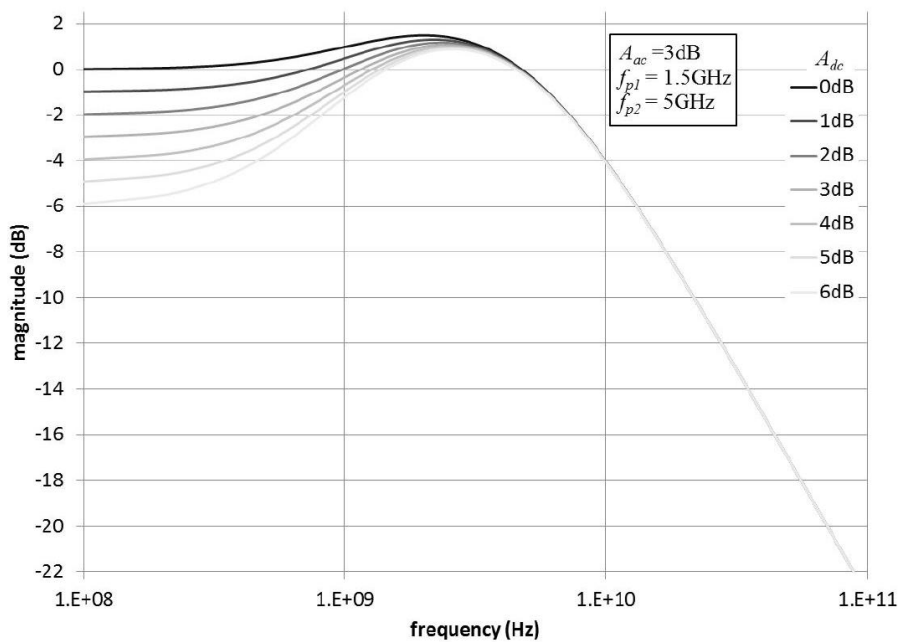

Figure 13. USB3.2 Gen2 Compliance Rx EQ Transfer Function

12 Appendix H – Applying DFE USB3.2 Gen2

Method

In addition to the 1st order CTLE, a one-tap reference DFE is used. The DFE behaviour is described by equation (12.1) and Figure 14. The limits on d_1 are 0 to 50mV.

$$(12.1) y_k = x_k - d_1 \text{sgn}(y_{k-1})$$

where y_k is the DFE differential output voltage
 y_k^* is the decision function output voltage, $|y_k^*| = 1$
 x_k is the DFE differential input voltage
 d_1 is the DFE feedback coefficient
 k is the sample index in UI

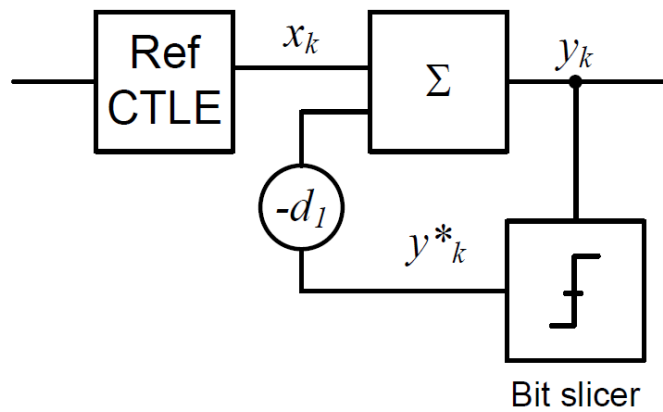

Figure 14. USB3.2 Gen2 reference DFE Function

13 Appendix I – Swing calibration for Time Domain stand - alone test.

Requirement

The differential swing shall be equal to the required in the LRD spec Table 1-2.

Test Method

1. Connect the Calibration Path setup according to the Figure 15.
2. Connect the calibration point to the scope.

Note:

- The path, including the coax cable and the connectors, to the Calibration Point shall be the same as for the test.
 - The calibration point shall be directly connected to the scope.
3. Choose a supported USB4 / USB3.2 speed to start with.
 4. Configure Generator transmit SQ512 (256 '1's followed by 256 '0') with SSC and all jitter including ACCM turned OFF.
 5. No TxFFE applied.
 6. Measure the differential swing using the scope configurations as following:
 - Sampling Rate $\geq 80\text{GSa/s}$
 - The evaluated record length shall be not less than 20us per channel.
 - No CDR, no average and no interpolation to be used.
 - Adjust vertical scale to fit signal into scope screen.
 - Scope BW shall be as specified in Appendix A.
 - Measure differential amplitude voltage of bits 248-253:
Mean value over bits 248-253 of the 256 '1's – Mean value over bits 248-253 of the 256 '0', for a waveform averaged over at least 20 repeats of the 512-bit pattern.

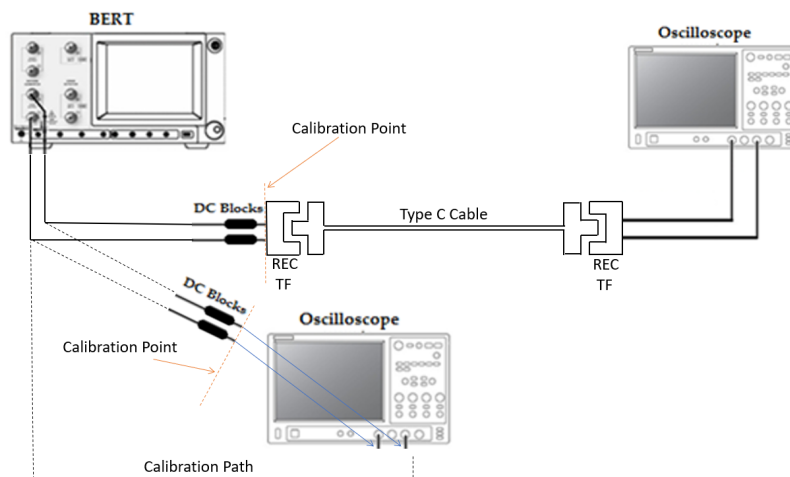

Figure 15. Swing calibration for Time Domain stand - alone test

14 Appendix J –USB4/USB3.2 Test Equipment

14.1 Overview

All equipment used for testing shall comply with the requirement lists specified below.

This includes the primary equipment that is used in the USB4/USB3.2 authorized test centers and may also be used by the end user for self-testing.

Other configurations and equipment may be used for self-testing as long as that equipment and the processes meet all of the stated and implied requirements and permit an equivalent level of testing.

14.2 Test Equipment Requirements

USB4/USB3.2 requirements

All test equipment requires calibration to ensure accurate and repeatable results. Equipment shall be calibrated prior to, and if necessary, during the test procedure.

14.2.1 Test Point Access Boards

To gain access to the required signals, a variety of test point access boards are required. Test Point Access boards provide test points for the pins on the USB4 USB Type-C connector and an easy way to control the DUT.

Recommended Test Equipment:

Wilder USB4 Plug and receptacle Test fixtures.

14.2.2 Real Time Scopes

Required Test Equipment Capabilities:

- DC to 21GHz, -3db bandwidth or greater
- 80G sample/sec Sampling rate or greater, sampling 2 channels simultaneously
- Sample memory: 50M samples per channel or greater
- 1st and 2nd order CDR capability
- Equalization of CTLE and DFE
- Jitter measurement
- Embedding/de-embedding capability

14.2.3 Pattern Generator

Generate USB4 signal with a variety of patterns, jitter injection capability.

Required Test Equipment Capabilities:

- Data rates \geq 20Gbps
- Data patterns: PRBS15, PRBS31, Square wave
- Differential swing range: 0 – 1.5Vp-p in 10mV steps

- Rise Time ≥ 10 ps (20%-80%)
- Intrinsic jitter ≤ 400 fS RMS
- Random Jitter profile no smaller than 500MHz
- Equalization
- SSC spread deviation from 0.03% down to -0.53%. Note – for Interoperability with Thunderbolt™ 3 (TBT3) Systems the SSC spread deviation shall be from 0.04% down to -0.54%.
- Injection of 1 SJ sources

14.2.4 Network Analyzer

Required Test Equipment Capabilities:

- Number of ports: minimum required is 4 ports
- Frequency: minimum required is 20GHz
- Dynamic range > 50db
- Time domain option

14.2.5 Signal Generator

Required Test Equipment Capabilities:

- Frequency range of at least 10- 400MHz
- Output power of ± 15 dBm

14.2.6 Accessories

14.2.6.1 Low Insertion Loss Phase Matched Cable:

Required Test Equipment Capabilities for 1m RF cable:

- Phase matched max of $\pm 5^\circ$ @ 40 GHz
 - Max IL in 10GHz < 1.5dB
- Note – any length of cable is permitted up to 1m.

14.2.6.2 ISI Channel

Required Test Equipment Capabilities:

Varied insertion loss of 2-10dB @5GHz and @10GHz

14.2.6.3 Pickoff Tee

Required Test Equipment Capabilities:

Pickoff tees with bandwidth of at least 40GHz

14.2.6.4 Splitter

Required Test Equipment Capabilities:

Splitter with bandwidth of at least 1GHz

14.2.6.5 DC Block

Required Test Equipment Capabilities:

- DC Blocks with bandwidth of at least 33GHz
- 1 dB Insertion Loss to 40 GHz
- Capacitance of 135nF-265nF (220nF is recommended)

14.2.6.6 USB4 Passive and Active cables

- USB Type-C 0.8m (Gen3 supported) and 2m (Gen2 supported) passive cables as described in the USB4 Specification. the cables should be e-marked.
- USB4 Active cable. The Active cable should be e-marked.

14.2.6.7 Termination

Required Test Equipment Capabilities:

- Impedance 50 ohm
- Frequency DC to 20 GHz

USB3.2 Special requirements (in addition to listed above):

14.2.7 BERT (Bit Error Tester)

Generate USB3.2 signal with a variety of patterns, jitter injection capability and Analyze Looped back data.

Minimum Required Test Equipment Capabilities:

- Data rates \geq 10Gbps
- Data patterns: All USB3.2 Specification defined pattern types, full complete link training and management capability, PRBS15, PRBS31, Square wave
- Injection of Rj and SJ (single/dual tone) sources
- Identify single Bit Error in looped back data pattern

Recommended Test equipment Capabilities

- Independent Dual Channel Generator and Error detector control including full dual lane link training capability
- Channel to channel flow control
- Arbitrary SSC profile

14.2.8 Real Time Scopes

Optional Test Equipment Capabilities for debug only, as SigTest is used:

- 1st and 2nd order CDR capability
- Equalization of CTLE and DFE
- Jitter measurement

15 Appendix K – LRD Functional setup

Figure 16 shows the LRD functional setup which shall be used as a part of the entire setup in the frequency and the time domains described in the sections 2, 3, 4. The software tool controlled by PC is able to enter the LRD cable to the desired speed. The tool will be available in the USB-IF.

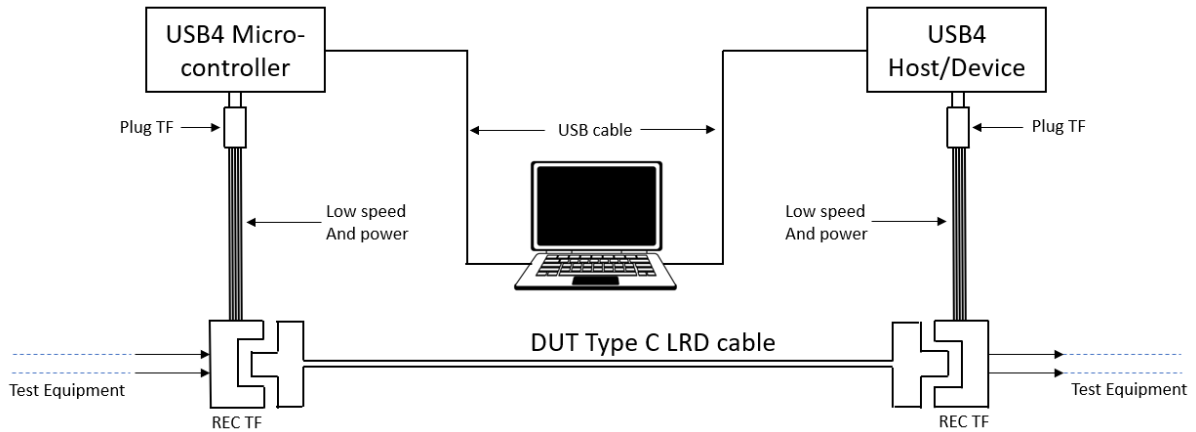

Figure 16. LRD Functional setup

Note: The LRD Functional setup will be an optional for current LRD CTS revision.

16 Appendix L – Pre-Certification phase

This appendix details the process that LRD based active cable vendor shall perform before submitting cables for certification.

The goal of this phase is to ensure that the cable will meet the spec also when considering the LRD IC and cable assembly variants (which expected to be significant in long cables with active components).

Cable vendor shall randomly select 100 cables, and test each lane with rough performance evaluator (see details below).

Once all cables are sorted by performance level, the vendor shall submit 6 cables for full certification:

- 1) 2 cables with the best performance
- 2) 2 cable with the worst performance
- 3) 2 random cables

The above 6 cables will go through the entire certification testing as described in this document.

The performance evaluator shall meet these requirements:

- 1) Allow similar performance metric for all cables
- 2) Evaluate at least one of the following:
 - a. Time-Domain eye height (for instance: using USB3/4 device with capability to report EH)
 - b. Time-Domain eye width (for instance: using USB3/4 device with capability to report EW)
 - c. Frequency-Domain IL_{atNq} (insertion loss at Nyquist frequency) (for instance: using VNA to measure single frequency point)
- 3) The evaluation shall be done only for the highest supported rate

All the evaluation data for the entire 100 cables shall be provided along with the 6 cables submitted for certification in a spreadsheet with the following format:

Cable unique ID	Lane	Evaluator type	Performance

Table 5. Pre-Certification data

Cable vendor shall mark the 6 cables submitted for certification with their unique ID.