

Wii™

# SONIC™ COLORS



SEGA®

INSTRUCTION BOOKLET

**PLEASE CAREFULLY READ THE Wii™ OPERATIONS MANUAL COMPLETELY BEFORE USING YOUR Wii HARDWARE SYSTEM, GAME DISC OR ACCESSORY. THIS MANUAL CONTAINS IMPORTANT HEALTH AND SAFETY INFORMATION.**

**IMPORTANT SAFETY INFORMATION: READ THE FOLLOWING WARNINGS BEFORE YOU OR YOUR CHILD PLAY VIDEO GAMES.**

### **⚠ WARNING - Seizures**

- Some people (about 1 in 4000) may have seizures or blackouts triggered by light flashes or patterns, and this may occur while they are watching TV or playing video games, even if they have never had a seizure before.
- Anyone who has had a seizure, loss of awareness, or other symptom linked to an epileptic condition should consult a doctor before playing a video game.
- Parents should watch their children play video games. Stop playing and consult a doctor if you or your child has any of the following symptoms:

Convulsions	Eye or muscle twitching	Altered vision
Loss of awareness	Involuntary movements	Disorientation

- To reduce the likelihood of a seizure when playing video games:
  1. Sit or stand as far from the screen as possible.
  2. Play video games on the smallest available television screen.
  3. Do not play if you are tired or need sleep.
  4. Play in a well-lit room.
  5. Take a 10 to 15 minute break every hour.

### **⚠ WARNING - Repetitive Motion Injuries and Eyestrain**

Playing video games can make your muscles, joints, skin or eyes hurt. Follow these instructions to avoid problems such as tendinitis, carpal tunnel syndrome, skin irritation or eyestrain:

- Avoid excessive play. Parents should monitor their children for appropriate play.
- Take a 10 to 15 minute break every hour, even if you don't think you need it.
- If your hands, wrists, arms or eyes become tired or sore while playing, or if you feel symptoms such as tingling, numbness, burning or stiffness, stop and rest for several hours before playing again.
- If you continue to have any of the above symptoms or other discomfort during or after play, stop playing and see a doctor.

### **⚠ CAUTION - Motion Sickness**

Playing video games can cause motion sickness in some players. If you or your child feel dizzy or nauseous when playing video games, stop playing and rest. Do not drive or engage in other demanding activity until you feel better.

### **IMPORTANT LEGAL INFORMATION**

This Nintendo game is not designed for use with any unauthorized device. Use of any such device will invalidate your Nintendo product warranty. Copying of any Nintendo game is illegal and is strictly prohibited by domestic and international intellectual property laws. "Back-up" or "archival" copies are not authorized and are not necessary to protect your software. Violators will be prosecuted.





*The Official Seal is your assurance that this product is licensed or manufactured by Nintendo. Always look for this seal when buying video game systems, accessories, games and related products.*



Trademarks are property of their respective owners. Wii is a trademark of Nintendo. © 2006 Nintendo.

Licensed by Nintendo



This software uses fonts produced by FONTWORKS Inc. FONTWORKS, and font names are trademarks or registered trademarks of FONTWORKS Inc.



Copyright 2009 NVIDIA Corporation. NVIDIA and PhysX, both stylized and non-stylized, are trademarks or registered trademarks of NVIDIA Corporation.

Copyright © 1994-2008 Lua.org, PUC-Rio.

Permission is hereby granted, free of charge, to any person obtaining a copy of this software and associated documentation files (the "Software"), to deal in the Software without restriction, including without limitation the rights to use, copy, modify, merge, publish, distribute, sublicense, and/or sell copies of the Software, and to permit persons to whom the Software is furnished to do so, subject to the following conditions:

The above copyright notice and this permission notice shall be included in all copies or substantial portions of the Software.

THE SOFTWARE IS PROVIDED "AS IS", WITHOUT WARRANTY OF ANY KIND, EXPRESS OR IMPLIED, INCLUDING BUT NOT LIMITED TO THE WARRANTIES OF MERCHANTABILITY, FITNESS FOR A PARTICULAR PURPOSE AND NONINFRINGEMENT. IN NO EVENT SHALL THE AUTHORS OR COPYRIGHT HOLDERS BE LIABLE FOR ANY CLAIM, DAMAGES OR OTHER LIABILITY, WHETHER IN AN ACTION OF CONTRACT, TORT OR OTHERWISE, ARISING FROM, OUT OF OR IN CONNECTION WITH THE SOFTWARE OR THE USE OR OTHER DEALINGS IN THE SOFTWARE.

### SYSTEM MENU UPDATE

Please note that when first loading the Game Disc into the Wii console, the Wii will check if you have the latest system menu, and if necessary a Wii system update screen will appear. Press OK to proceed.

When the system menu is updated, unauthorized hardware and/or software modifications may be detected and unauthorized content may be removed causing the immediate or delayed inoperability of your console. Failure to accept the update may render this game, and future games, unplayable. Please note that Nintendo cannot guarantee that unauthorized software or accessories will continue to function with the Wii console after this or future updates of the Wii system menu.

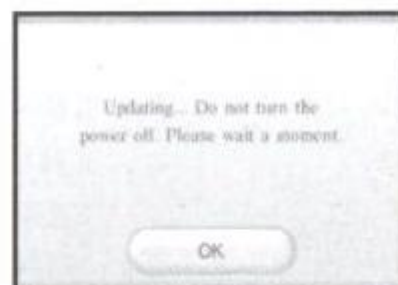

### ▲ CAUTION: WRIST STRAP USE

Please use the wrist strap to help prevent injury to other people or damage to surrounding objects or the Wii Remote in case you accidentally let go of the Wii Remote during game play.

Also remember the following:

- Make sure all players put on the wrist strap properly when it is their turn.
- Do not let go of the Wii Remote during game play.
- Dry your hands if they become moist.
- Allow adequate room around you during game play and make sure that all areas you might move into are clear of other people and objects.
- Stay at least three feet from the television.
- Use the Wii Remote Jacket.

Thank you for purchasing *Sonic Colors*<sup>TM</sup>. Please note that this game is designed only for use with the Wii<sup>TM</sup>. Be sure to read this instruction booklet thoroughly before you start playing.

# SONIC<sup>TM</sup> COLORS

## CONTENTS

STORY .....	3
CHARACTERS .....	4
CONTROLLERS .....	6
STARTING UP .....	7
HOW TO PLAY .....	8
EGGMAN'S SONIC SIMULATOR .....	18
OPTIONS .....	20



## »»»STORY

After years in the making, Eggman's Incredible Interstellar Amusement Park is finally finished! The genius scientist claims he created this gigantic playland to make up for all the trouble he had caused over the years, but Sonic is suspicious.

"You can fool others, but you can't fool me!" says the world's fastest hedgehog.

Before opening day, Sonic and his best buddy, Tails, race to the park to see what Eggman is really up to.



# »»» CHARACTERS

## **Sonic the Hedgehog**

Sonic is a hedgehog who loves freedom and the truth. He can't leave anyone in need of help and he's spent years rescuing victims from Dr. Eggman's conniving schemes. He knows better than to believe the rotund scientist, especially when Dr. Eggman claims he's doing something nice.

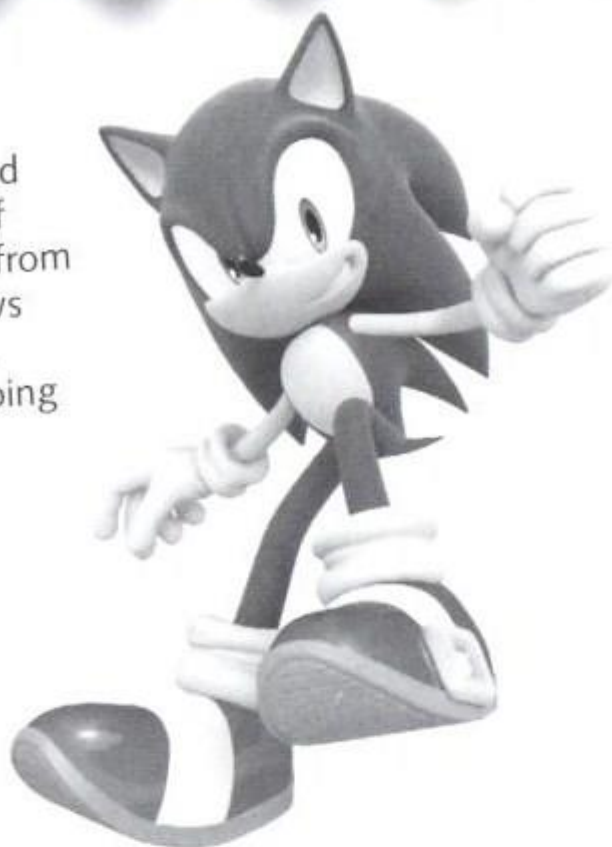

## **Miles "Tails" Prower**

Tails is a flying, two-tailed fox who helps Sonic out on his many adventures. Tails' mechanical genius often gets them out of trouble and helps them stay just ahead of Dr. Eggman's henchmen. In *Sonic Colors*, Tails builds a translator that lets them communicate with the Wisps who are being captured by Dr. Eggman.

## **Yacker**

Yacker is a curly haired White Wisp who barely escaped from Dr. Eggman's evil robots. He asks Sonic and Tails to help him save the Wisps who are being held captive and the three of them set out on their journey.



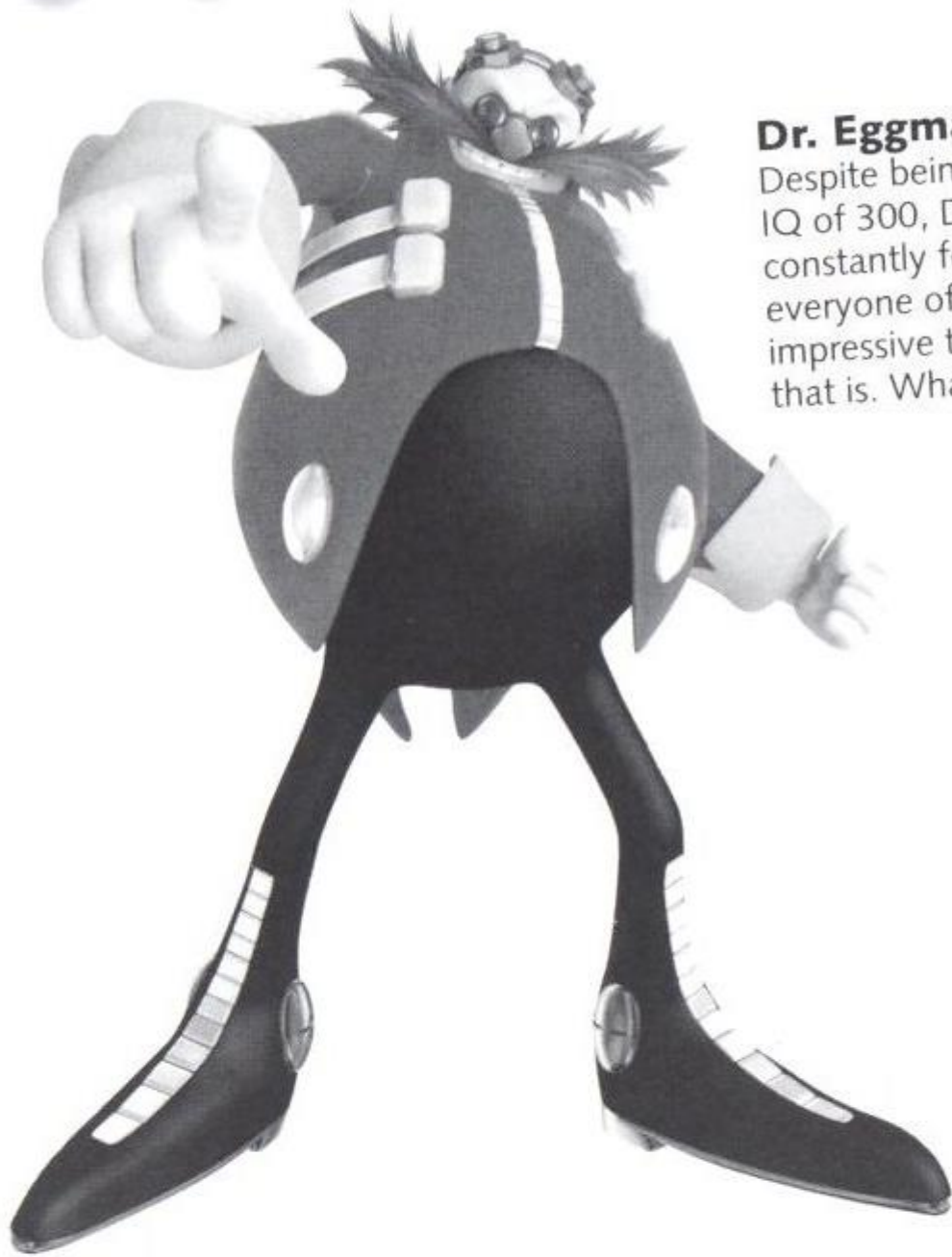

### **Dr. Eggman**

Despite being a scientific genius with an IQ of 300, Dr. Eggman's evil plans are constantly foiled by Sonic. He's convinced everyone of his generosity with his impressive theme park – everyone but Sonic that is. What is he really after...?

### **Orbot**

Orbot was built by Dr. Eggman to wait on him hand and foot. Though Orbot obeys Dr. Eggman faithfully, he really doesn't like him very much.



### **Cubot**

Cubot is another one of Dr. Eggman's creations, paired with Orbot to perform various duties. He likes Dr. Eggman, but he is lazy and tries to get out of doing any work.



# CONTROLLERS

This game can be controlled in various ways, depending on the controllers available. The game will automatically detect what you have.

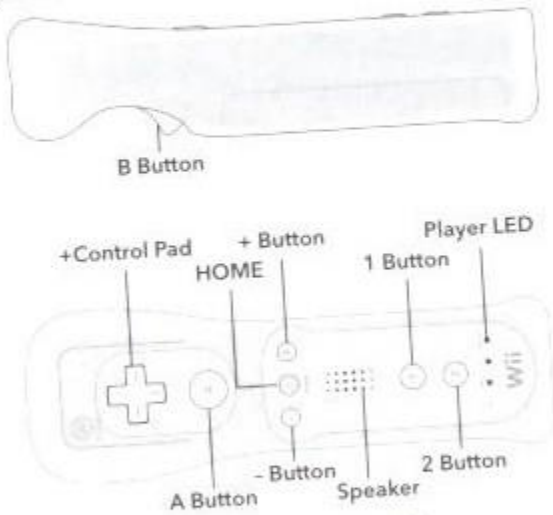

**Wii Remote™**

Hold the **Wii Remote** sideways to play.

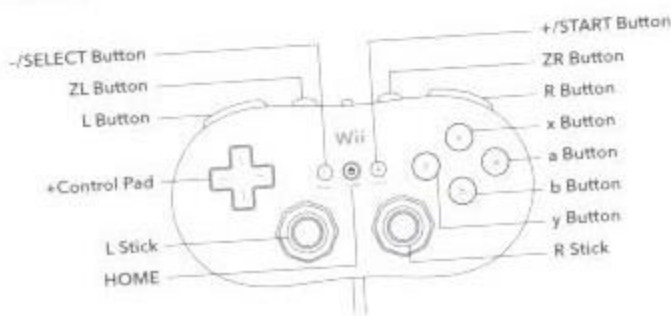

**Classic Controller™**

Connect to **Wii Remote** to play in **Classic Style**. The controls on the **Wii Remote** will be disabled. The game is also compatible with the **Classic Controller Pro™**.

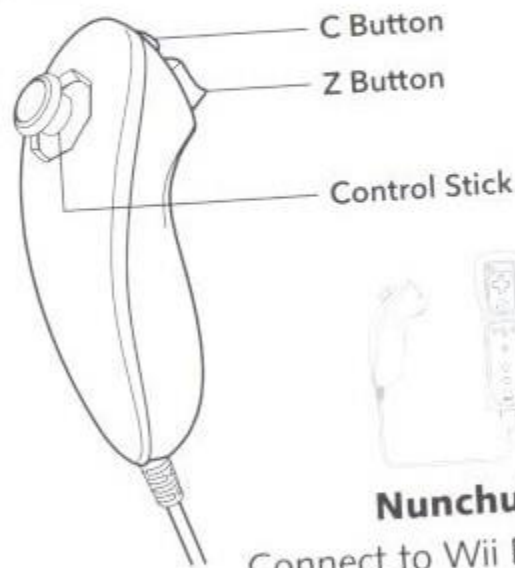

**Nunchuk™**

Connect to **Wii Remote** to play in **Nunchuk Style**.

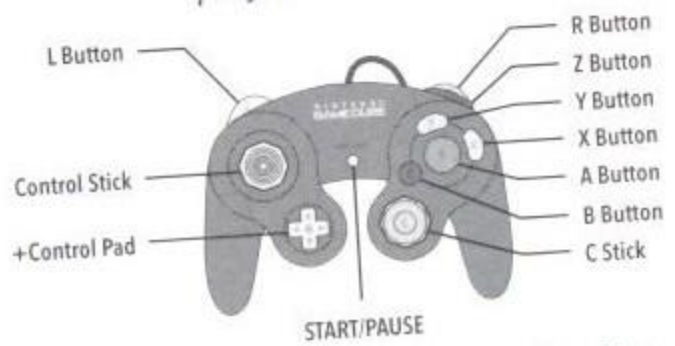



**Nintendo GameCube™ Controller**

Connect the **GameCube Controller** to the **Nintendo GameCube Controller Socket 1** (**Controller Socket 2** for player 2's in **Eggman's Sonic Simulator**, p.18).

## Menu Controls

	<b>Nunchuk Style</b>	<b>Wii Remote Sideways</b>	<b>Classic Style</b>	<b>GameCube Controller</b>
Select/ Move Cursor	Control Stick	+Control Pad	L Stick	Control Stick
Confirm/ Choose	A Button	2 Button	a Button	A Button
Back/Cancel	B Button	1 Button	b Button	B Button

If you see a flashing  / , use the Control Stick (+Control Pad in **Wii Remote Sideways**, L Stick in **Classic Style**) to switch between the lists. Henceforth all controls will be described in **Nunchuk Style**, with the buttons used in **italicized bold face**. Refer to the chart following the control description for the button to be used in your controller combination. Also, the button functions during the non-playing screens will be displayed at the bottom of the screen.



# STARTING UP

At the Title Screen, press the **+ Button** to select from the following:



<b>Wii Remote Sideways</b> + Button	<b>Classic Style</b> +/START Button	<b>GameCube Controller</b> START/PAUSE
--	--	---

## New Game

The first time you play *Sonic Colors*, you will be asked whether you wish to play with the Navigator **ON** or **OFF**.

For Navigator information, see p.16 for details.

After you play the first two Acts of the game, you will be asked to select a slot to store your savedata. There are six slots available. Select an empty slot marked **No Data** to save your data.

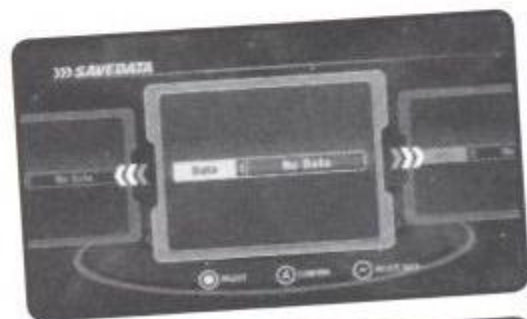

Use the on-screen keyboard to enter your name. When you've finished, select **OK** to continue.



Finally, select a Mii or Icon for your save data.



## Continue

Select a slot for the savedata you wish to use when you resume your game. You can also delete the save data by pressing the **- Button**.



<b>Wii Remote Sideways</b> - Button	<b>Classic Style</b> -/SELECT Button	<b>GameCube Controller</b> Z Button
--	---	--



# »»»HOW TO PLAY

## Game Controls

### Move / Quick Step / Grind Step

Sonic will move in the direction you press the **Control Stick**. Press a little to walk, and all the way to run. Press the **Control Stick** in the opposite direction to brake. There are also places where Sonic dives slowly to the ground. Use the **Control Stick** to guide the direction of his descent.



In some parts of the game a special icon (shown here) will appear. Here Sonic can run quickly toward an enemy or away from danger. Press the **Control Stick** left/right to Quick Step. Sonic can also get close to the enemy to attack using Quick Step.



While on a grind rail, press the **Control Stick** left/right to hop onto another parallel grind rail. This maneuver is possible only during the 3D sections of the Act.



Wii Remote Sideways	Classic Style	GameCube Controller
+Control Pad	L Stick	Control Stick

### Jump / Spin Attack / Double Jump

Tap the **A Button** to Hop, or press down firmly to perform a Spin Attack. Sonic can attack the enemy with the Spin Attack. During the Jump/Spin Attack, press the **A Button** again to perform a Double Jump.

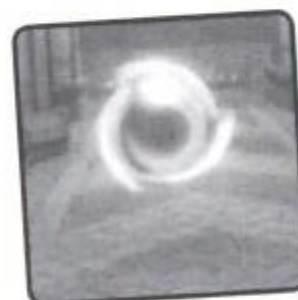

Wii Remote Sideways	Classic Style	GameCube Controller
2 Button	a Button	A Button

### Wall Jump

Jump towards a wall and hold the Control Stick towards the wall to "land" or grab onto it; then jump again by pressing the **A Button**. This maneuver can only be performed in 2D side-scrolling sections of the Act, not in 3D sections.



Wii Remote Sideways	Classic Style	GameCube Controller
+Control Pad ↘ 2 Button	L Stick ↘ a Button	Control Stick ↘ A Button



## Homing Attack

While airborne, lock-onto an enemy using the marker and press the **A Button** to perform a Homing Attack.



Wii Remote Sideways	Classic Style	GameCube Controller
2 Button	a Button	A Button

## Crouch / Slide

While standing still, press the **Z Button** to Crouch. You can also press the **Z Button** while running to Slide. These moves are useful in areas with very low ceilings.



Wii Remote Sideways	Classic Style	GameCube Controller
B Button	x Button	X Button

## Stomp

While airborne you will encounter objects that Sonic can stomp on to gain access. For example, Stomping on a fragile floor will allow Sonic to break through it. Press the **Z Button** once to stomp an object, and press the **Z Button** again to quickly land on the ground.



Wii Remote Sideways	Classic Style	GameCube Controller
B Button	x Button	X Button

## Drift

Hold the **B Button** while making a turn and press the **Control Stick** in the direction of the turn (left/right) to allow Sonic to make tight turns without slowing down. This maneuver is only possible in parts when the Drift icon (as shown here) is displayed.



Wii Remote Sideways	Classic Style	GameCube Controller
1 Button + +Control Pad	b Button + L Stick	B Button + Control Stick



## Boost / Air Boost / Jump Dash

Press the **B Button** to Boost Sonic's speed. You can hold the button to Boost continuously. Use it carefully as the Boost maneuver drains the Boost Gauge. You cannot Boost if the gauge is empty.

While Boosting, Sonic can tackle enemies that are in the way and grab nearby Rings.

You can also Boost while airborne, but once you release the button, you cannot Boost again until you land on the ground. If the Boost Gauge is empty, you will only dash forward for a short distance.

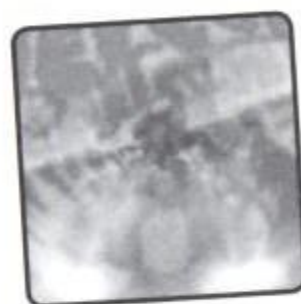

Wii Remote Sideways	Classic Style	GameCube Controller
1 Button	b Button	B Button

## Unleash Color Power

With the exception of the White Wisps, when you have a Wisp in your grasp, **shake the Wii Remote** to unleash its power. The Color Power uses the Boost Gauge, and the effect will end when the gauge is depleted completely. While the Color Power is in effect, collect a Wisp Capsule of the same kind of Wisp you are holding to replenish the Boost Gauge and extend the duration of the effect. Please also refer to the Wisp section (p.11) for the controls to use when the Color Power is in effect.



Wii Remote Sideways	Classic Style	GameCube Controller
Shake Wii Remote	R Button	Z Button

## Pause Menu

Press the **+ Button** to pause the game. You have the following options:

**CONTINUE**

Resume the game. Pressing the **+ Button** again has the same effect.

**RESTART**

Restart from the beginning of the Act.

**EXIT**

Quit and return to the Area Map.



Wii Remote Sideways	Classic Style	GameCube Controller
+ Button	+ / START Button	START / PAUSE



# Wisps

Wisps are alien life forms that live on Planet Wisp. There are different kinds of Wisps, and each type possesses a distinct Color Power which Dr. Eggman is after. Find and collect Wisp Capsules to recharge the Wisps (or in the case of the White Wisps, charge a given amount on your Boost Gauge).

## White Wisps

The most common type of Wisp, the White Wisps are very friendly and love to talk. They do not have the power to transform, but they can give Sonic a Boost.



## Cyan Wisps

Cyan Wisps are a special breed. They are very fast, never seem to stop moving and as a result they can seem a little scatterbrained. Their powers allow Sonic to transform into the Cyan Laser.



### Cyan Laser

When Sonic transforms into the Cyan Laser, be sure to look for prisms (left) and optical cables (right). Shoot at them and see what happens!

	Wii Remote Sideways	Classic Style	GameCube Controller
Aim	+Control Pad	L Stick	Control Stick



When Sonic is transforms into the Cyan Laser, be sure to look for prisms (left) and optical cables (right). Shoot at them and see what happens!

## Yellow Wisps

Yellow Wisps are very fond of earth and water. Their powers allow Sonic to transform into the Yellow Drill to reach underground and underwater spots quickly.

### Yellow Drill

Position Sonic where you want him to drill. Press the B Button if you want to drill quickly. Once Sonic is underground or underwater he can move about quickly as the Yellow Drill, but keep your eye on the Boost Gauge. If the gauge runs out while you're still underground, you will lose a try. Sonic reverts to his normal self when he resurfaces.

The Yellow Drill can only be activated in the 2D side-scrolling sections of the Acts.



	Wii Remote Sideways	Classic Style	GameCube Controller
Move	+Control Pad	L Stick	Control Stick
Speed Up	1 Button	b Button	B Button



## Blue Wisps

Blue Wisps have sharp minds and make excellent leaders. Whenever they decide to do something big, the Blue Wisps are almost always successful. Their powers allow Sonic to become indestructible as the Blue Cube for a short while.

### Blue Cube

After activation, all Blue Blocks turn into Blue Rings, and vice versa. When the Boost Gauge runs out, the Blue Blocks and Blue Rings revert to their original shape. Note that Blue Rings can be collected, while Blue Blocks are indestructible and cannot be collected.



Blue Block



Blue Ring

## Orange Wisps

Orange Wisps are very sensitive, emotional Wisps. They are easily elated when praised, but they can also get depressed if they've made a mistake. Be careful not to upset them, they can get angry very easily. Luckily, Sonic reaps the benefits of their powerful emotions when they transform him into an Orange Rocket.



### Orange Rocket

As the Orange Rocket, he shoots straight up in the air. He will return to the ground slowly after he hits a ceiling or the Boost Gauge runs out.

The Orange Rocket can only be activated in the 2D side-scrolling sections of the Acts.

## Green Wisps

Green Wisps are subtle, yet pretty goofy. You never know when you might come across one, but keep an eye out for them when you're flying. They give Sonic the power to hover.

### Green Hover

Once Sonic transforms into the Green Hover, use the **Control Stick** to move him horizontally. Press and hold the **A Button** to hover and release to descend. Press the **B Button** near a series of Rings to perform a Ring Dash. Sonic will revert to his normal form when the Boost Gauge runs out.



	Wii Remote Sideways	Classic Style	GameCube Controller
Move	+Control Pad	L Stick	Control Stick
Hover	2 Button	a Button	A Button
Ring Dash	1 Button	b Button	B Button



## Pink Wisps

Pink Wisps can be somewhat harsh, but they are in fact very kind by nature. You'll often find them near walls. Utilize the powers of the Pink Wisps to transform Sonic into the Pink Spikes so he can move around easily in all directions when on a wall.

### Pink Spikes

Once Sonic has been transformed into the Pink Spikes, point Sonic at a wall and press the **A Button** to Jump to the wall and grab it. Press the **Control Stick** in any direction you choose to move Sonic along the wall – he can even hang upside down! You can accelerate with the **B Button**.

Sonic can only transform into the Pink Spikes in the 2D side-scrolling sections of the Acts.



	Wii Remote Sideways	Classic Style	GameCube Controller
Move	+Control Pad	L Stick	Control Stick
Jump	2 Button	a Button	A Button
Accelerate	1 Button	b Button	B Button



## Purple Wisps

Once Wisps are captured by Dr. Eggman, they are converted into Nega-Wisps, like the Purple Wisps. These unfortunate Wisps are violent and are forced to carry out Dr. Eggman's evil plans.

### Purple Frenzy

Transform Sonic into the Purple Frenzy and move him around using the **Control Stick**. Press the **A Button** to Jump. The Purple Frenzy can eat up certain obstacles that normally can't be destroyed.

	Wii Remote Sideways	Classic Style	GameCube Controller
Move	+Control Pad	L Stick	Control Stick
Jump	2 Button	a Button	A Button

## Where are the Wisps?

In the early stages of play, you must search for all the different colored Wisps (except the White Wisps) in order to use their powers and collect certain items. You may find empty Wisp Capsules, but just keep searching. Please note that the Wisp you are looking for might be in a different Act and there are some you won't find until later in the game. If you come across a particular item that you cannot retrieve without a certain Wisp, remember where the item is located and return to collect it after you find the Wisp.





## Game Screen

The Acts generally consist of 3D sections and 2D side-scrolling sections. The information displayed on the screen is basically the same in all sections:

- 1 Tries Remaining
- 2 Rings Collected
- 3 Elapsed Time
- 4 Score
- 5 Color Power Obtained
- 6 Boost Gauge
- 7 Star Rings Obtained



3D Section



2D Side-scrolling Section

The 3D sections also have Quick Step parts where you move forward either manually or automatically. In some of these parts, you have limited controls other than Quick Step.



## Clearing the Acts

Your primary objective in each Act is to complete a particular goal. There are two types of Acts, each with different goals.



Act with Prison Capsule



Act with Goal Ring



## Taking Damage

If you are hit by enemies, enemy shots, or harmful objects with no Rings in possession, you will lose a try. If you have even one Ring in possession, it will protect you once, but you will lose all of your Rings.

Some parts of the Acts take place underwater. Sonic cannot stay underwater for too long without air. When the countdown begins, resurface or find an air bubble to breathe before the countdown runs out. If it does, you will lose a try regardless of the Rings you have. There are also places where Sonic could fall into a bottomless abyss. Be careful as you will automatically lose a try if you fall into such a pit.



Whenever you lose a try, if you have any remaining, you will restart from the last Checkpoint gate you passed. If you lose all your tries, the Game Over screen will be displayed. You will restart from the Area Map (p.17) with the default number of tries (five).

**Note:** The number of tries remaining at the end of the Act (including Boss Battle below) will carry over to the next Act you choose to play.

## Boss Battle

In each Area, the passage to the Area Boss will eventually open. Observe their weaknesses to find a way to defeat them.

In a Boss Battle, if you lose a try, you must restart from the beginning of the battle.

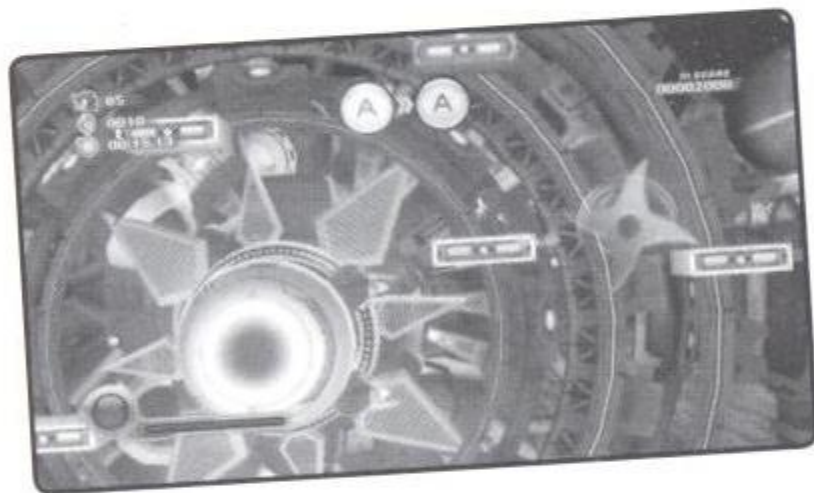

## Results Screen

After the end of the Act (or Boss Battle), your Score and Rank will be given based on the time it took you to finish and the number of Rings in your possession. Press the **- Button** to replay the same Act again, or the **+ Button** to proceed to next Act via the Area Map.



	Wii Remote Sideways	Classic Style	GameCube Controller
Try Again	- Button	-/SELECT Button	Z Button
Next	+ Button	+ /START Button	START/PAUSE



## Items

When you come across various items in the Act, touch them to collect them. Here are the items to look for:



### Ring

Adds one Ring to your collection.



### Special Ring

These Special Rings allow you to unlock Acts you can play in Eggman's Sonic Simulator (p.18).



### Hint Ring

See Navigator below.



### Super Ring

Adds a varying number of Rings to your collection.



### 1UP

Definitely hunt for this item – it gives you one extra try.

## Navigator

Set the Navigator (p.7, p.20) to **ON** to find Hint Rings in various places throughout the Acts. When you approach a Hint Ring, a hint will be given on what to do and how to do it.

**Note:** If you run out of tries twice in a row on the same Act, you will be asked whether you want to turn the Navigator **ON** during the Game Over screen.



## Gimmicks

Here are some of the gimmicks you will find in the game. Note that some gimmicks are also possible targets for the Homing Attack.



### Spring

Bounces Sonic rapidly in a given direction.



### Rainbow Ring

Passing through a Rainbow Ring will launch Sonic into the air.



### Springboard

Run over it to launch Sonic into the air.



### Dash Panel

Sends Sonic running super fast in a set direction.



### Dash Ring

When you pass through a Dash Ring, Sonic will launch into the air.



## Area Map

The Area Map displays the Acts that are currently available to play. Choose either a newly opened Act to advance the story, or a previously played Act to improve your Records.

- 1 Tries Remaining
- 2 Number of S Ranks Earned/Total S Ranks Possible
- 3 Special Rings Obtained/Total Available in the Area
- 4 Selected Act
- 5 Wisp(s) Appearing in the Act
- 6 Control Guide



When you clear an Act, a passage to the next Act will open. The green spots indicate the normal Acts that are cleared, and the red spot indicates an Act which has not been cleared yet. Above each green spot, you will find your best Rating and the number of Special Rings collected for that Act.



Press the **- Button** to view the Records of the Area.



<b>Wii Remote Sideways</b>	<b>Classic Style</b>	<b>GameCube Controller</b>
- Button	-/SELECT Button	Z Button

## World Map

The World Map displays Areas that are currently available to play. The lock icon indicates that the selected Area is still locked and inaccessible until a condition is met.

- 1 Tries Remaining
- 2 Number of S Ranks Earned/Total S Ranks Possible
- 3 Game Land — access Eggman's Sonic Simulator (p. 18)
- 4 Game Land — access Eggman's Sonic Simulator (p.18)
- 5 Secret — unlock to find out!
- 6 Options Screen (p.20)
- 7 Control Guide

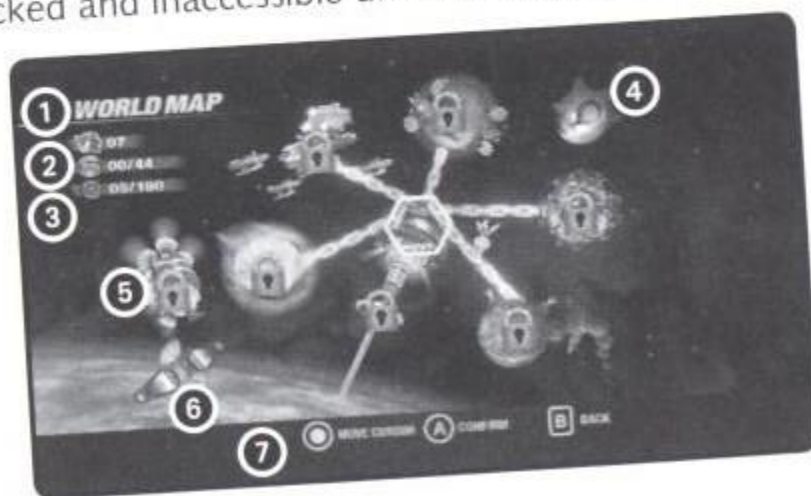



# »» EGGMAN'S SONIC SIMULATOR

At Game Land, you will play Eggman's Sonic Simulator, where two players cooperate to control the Virtual Hedgehog to reach the goal of the selected Act. The rule for each mode is different.

## How to Start

At the Eggman's Sonic Simulator's main menu, select the mode to play and the character to use (you will be able to select a Mii as the main game progresses). Then, select SPEED (Sonic's top running speed: 100% with five stars), and LIMITER (when set to **ON**, the top speed of the player running ahead decreases).



Next, select the Act to play. The Act you can play depends on the Special Rings earned in the main game. You can also view a quick chart of the Records of the Acts by pressing the **- Button**.



<b>Wii Remote Sideways</b> - Button	<b>Classic Style</b> -/SELECT Button	<b>GameCube Controller</b> Z Button
--	---	--

## 1 PLAYER

Play two characters by yourself. You will control one character, while the other character follows in an orb of light.

### Switch Characters

This control is available for 1 PLAYER only. Press the **2 Button** to switch between the two characters. This is especially useful when you wish to stock up Wisps for each character. Note that when the Color Power is unleashed, you cannot switch until the effect ends.



<b>Wii Remote Sideways</b> A Button	<b>Classic Style</b> y Button	<b>GameCube Controller</b> Y Button
--	----------------------------------	--

## 1.5 PLAYER

In this mode, Player 1 plays normally, while Player 2 supports Player 1. If there is no input on Player 2's Controller, the second character will appear in an orb of light and follow Player 1 until the **A** or **B Button** is pressed.

There is one score, one Boost Gauge and only one place to collect Wisps for both players in this mode. Player 1 must work not to lose tries while Player 2 will not be affected if they lose.



<b>Wii Remote Sideways</b> 2 or A Button	<b>Classic Style</b> a or y Button	<b>GameCube Controller</b> A or Y Button
---	---------------------------------------	---



## 2 PLAYER

In this mode, two players cooperate with one another to reach the goal.

Whenever one player loses their try, they will re-enter as an orb of light with no control. Press the **A Button** to rejoin the game.



Wii Remote Sideways	Classic Style	GameCube Controller
2 Button	a Button	A Button

### Assist

Press the 2 Button to turn into an orb. In this state, you will not have control, but you will also be invulnerable. Press the **2 Button** again (or the **A Button**) to revert into Virtual Hedgehog. Note that only one player can turn into the orb at a time.

	Wii Remote Sideways	Classic Style	GameCube Controller
Assist	A Button	y Button	Y Button
Revert	A or 2 Button	y or a Button	Y or A Button

### Pulling Back Front-Running Player

When the front-running player gets too far ahead of the other player, the trailing player will be dragged forward until they are stopped by a wall. When the arrow appears over the character at the wall, press the **Control Stick** in the indicated direction. This will pull the front-running player back to the wall. If the trailing player does not press the Control Stick, that player will lose his/her try.



Wii Remote Sideways	Classic Style	GameCube Controller
+Control Pad	L Stick	Control Stick

### Combined Form

This feature is only available in 2 PLAYER mode. If both players unleash their Color Power and are within a certain distance from one another, depending on the Wisps used, the two will combine to form one completely different color power (or two, depending on the combinations). Try and find out which pairs of Wisps can combine and how they work.



## Items & Gimmicks

These are some of the items and gimmicks that will appear in the Eggman's Sonic Simulator:



#### Egg Medal

There is one Egg Medal in each Act – be sure to hunt it down!



#### Punching Ball

When both players punch it from both sides, they'll get a lot of Rings.



#### Wisp Capsule

Each Wisp Capsule contains a different kind of Wisp and you often won't know what you're getting until you open it. Some capsules are empty until you have initial contact with that type of Wisp.



#### Spiral Door

When you see the Spiral Door, Boost into it to open it.



#### Slot Machine

Hit the arm to start. When you see three of the same item, it's yours!



# »»» OPTIONS

## Settings

Change settings for the game:

**NAVIGATOR**

Turn the Navigator **ON/OFF**.

**SOUND**

Choose the language of voices.

**TEXT**

Choose the language of text.

**Nintendo GameCube Controller Rumble Settings**

Turn the rumble feature of

Nintendo GameCube Controllers **ON/OFF** separately for Players 1 and 2.

(Lock Icon)

What could be unlocked if the condition is met? Find out!



## Theater

Select and view the movie scenes you have already watched in the game.

## Mii

Change Mii Characters or Change the Name of your savedata.

Note: To exit without changes, select **CANCEL**, then select **YES** to confirm your action.

## Leaderboards

If you had a particularly impressive score in an Area/Act, view your Record and register it to the Leaderboards.



## Combined Form

This feature is only available in 2 PLAYER mode. If both players unleash their Color Power and are within a certain distance from one another, depending on the Wisps used, the two will combine to form one completely different color power (or two, depending on the combinations). Try and find out which pairs of Wisps can be combined and how they work.

## Registering your Records

First select the Area/Act to register. Then, select the list of Records between **Local/TOP20/Friends**. Press the **- Button** to register your Record (or update the list). The list will be saved in your savedata until the next time you update the list.



	Wii Remote Sideways	Classic Style	GameCube Controller
Update	- Button	-/SELECT Button	Z Button

## Registering your Friends

At Wi-Fi top screen, press the **+ Button** to display a list of Friends that are registered. Select **Register a Friend** to register a friend. Select **OK** to register. By registering, you can view a list of your friend's Records. You can also delete a friend from the list if need be.

Note: You must have connected to the Nintendo Wi-Fi Connection at least once by registering (updating) your Records in order to obtain your Friend Code.



	Wii Remote Sideways	Classic Style	GameCube Controller
Register Friend	+ Button	+/START Button	START/PAUSE



## LIMITED WARRANTY:

SEGA of America, Inc. warrants to the original consumer purchaser that the game disc or cartridge shall be free from defects in material and workmanship for a period of 90-days from the original date of purchase. If a defect covered by this limited warranty occurs during this 90-day warranty period, the defective game disc or cartridge will be replaced free of charge. This limited warranty does not apply if the defects have been caused by negligence, accident, unreasonable use, modification, tampering, or any other causes not related to defective materials or manufacturing workmanship. This limited warranty does not apply to used software or to software acquired through private transactions between individuals or purchased from online auction sites. Please retain the original, or a photocopy, of your dated sales receipt to establish the date of purchase for in-warranty replacement. For replacement return the product, with its original packaging and receipt, to the retailer from which the software was originally purchased. In the event that you cannot obtain a replacement from the retailer, please contact SEGA to obtain support.

### Obtaining technical support/service

To receive additional support, including troubleshooting assistance, please contact SEGA at:

- Online: [help.sega.com](http://help.sega.com)
- Telephone: 1-800-USA-SEGA

## LIMITATIONS ON WARRANTY

ANY APPLICABLE IMPLIED WARRANTIES, INCLUDING WARRANTIES OF MERCHANTABILITY AND FITNESS FOR A PARTICULAR PURPOSE, ARE HEREBY LIMITED TO 90 DAYS FROM THE DATE OF PURCHASE AND ARE SUBJECT TO THE CONDITIONS SET FORTH HEREIN. IN NO EVENT SHALL SEGA OF AMERICA, INC. BE LIABLE FOR CONSEQUENTIAL OR INCIDENTAL DAMAGES RESULTING FROM THE BREACH OF ANY EXPRESS OR IMPLIED WARRANTIES. THE PROVISIONS OF THIS LIMITED WARRANTY ARE VALID IN THE UNITED STATES AND CANADA ONLY. SOME STATES DO NOT ALLOW LIMITATIONS ON HOW LONG AN IMPLIED WARRANTY LASTS, OR EXCLUSION OF CONSEQUENTIAL OR INCIDENTAL DAMAGES, SO THE ABOVE LIMITATION OR EXCLUSION MAY NOT APPLY TO YOU. THIS WARRANTY PROVIDES YOU WITH SPECIFIC LEGAL RIGHTS. YOU MAY HAVE OTHER RIGHTS THAT VARY FROM STATE TO STATE.

**To register this product, please go to [www.sega.com](http://www.sega.com)**

SEGA of America, Inc.  
350 Rhode Island Street, Suite 400, San Francisco, CA 94103

SEGA is registered in the U.S. Patent and Trademark Office. SEGA, the SEGA logo and Sonic Colors are either registered trademarks or trademarks of SEGA Corporation. © SEGA. All rights reserved.



# SONIC THE HEDGEHOG 4

EPISODE I



**AVAILABLE NOW!**

[www.sonicthehedgehog4.com](http://www.sonicthehedgehog4.com)

**SEGA**<sup>®</sup>

**WiiWare**<sup>™</sup>

**SONIC TEAM**



SEGA of America, Inc. 350 Rhode Island Street, Suite 400, San Francisco, CA 94103  
SEGA is registered in the U.S. Patent and Trademark Office. SEGA, the SEGA logo, the SONIC TEAM logo, and SONIC THE HEDGEHOG are either registered trademarks or trademarks of SEGA Corporation. © SEGA. All rights reserved. Wii and the Wii logo are trademarks of Nintendo. © 2006 Nintendo. WiiWare is available only through the Wii console. Part # MNL65042

PRINTED IN THE U.S.A.