

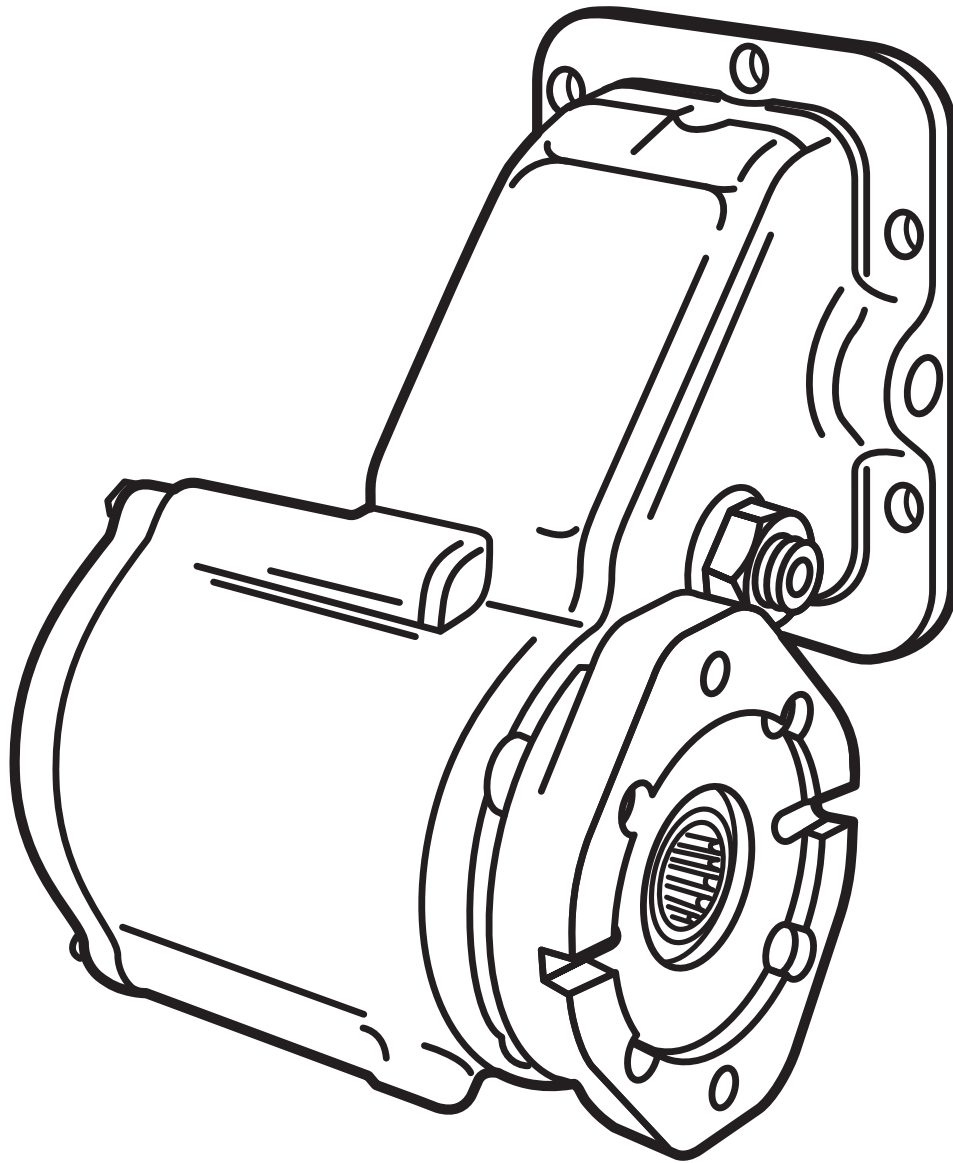

FA SERIES
FORD AUTOMATIC PTO
PARTS LIST AND SERVICE MANUAL



PARTS LIST AND DESCRIPTION

ITEM	QTY	PART NO.	DESCRIPTION
1	1	03T36247	Input Gear
2	2	10T36244	Input Bearing
3*	1	18T36282	Input Bearing Spacer (.110/.106")(Blue)
	1	18T36281	Input Bearing Spacer (.116/.112")(Beige)
	1	18T36257	Input Bearing Spacer (.122/.118")(Red)
	1	18T36256	Input Bearing Spacer (.128/.124")(Alum.)
	1	18T36255	Input Bearing Spacer (.134/.130")(White)
4	2	12T37037	O-ring
5	1	07T36243	Input Idler Shaft
6	1	19T36249	Set Screw
7	1	08T37194	Idler Shaft
8*	2	10T40073	Tapered Roller Bearing
9*	1	18T37245	Idler Bearing Spacer (.2526/.2496")(White)
	1	18T37246	Idler Bearing Spacer (.2476/.2446")(Yellow)
	1	18T37247	Idler Bearing Spacer (.2426/.2396")(Pink)
	1	18T37248	Idler Bearing Spacer (.2376/.2346")(Orange)
	1	18T37249	Idler Bearing Spacer (.2326/.2296")(Green)
	1	18T37250	Idler Bearing Spacer (.2276/.2246")(Brown)
	1	18T37251	Idler Bearing Spacer (.2226/.2196")(Red)
	1	18T37252	Idler Bearing Spacer (.2176/.2146")(Blue)
	1	18T37253	Idler Bearing Spacer (.2126/.2096")(Black)
10*	1	04T37190	Reverse Idler Gear
11	1	12T37701	O-ring
12	1	12T37203	O-ring
13	1	22T37322	Flange Nut
14	1	15T36568	Cover (FA62 Only)
	1	15T37289	Cover (FA64 Only)
15	1	12T36280	O-ring
16	1	12T36279	Cover O-ring (FA62 Only)
	1	12T37278	Cover O-ring (FA64 Only)
17	2	10T21017	Bearing (FA62 Only)
	1	10T37320	Bearing (FA64 Only)
18	1	01T37306	Housing (FA62 Only)
	1	01T37238	Housing (FA64 Only)
19	1	24T23937	Snap Ring (FA62 Only)
		24T37625	Snap Ring (FA64 Only)
21	2	12T36877	O-ring (FA62 Only)
	2	12T37321	O-ring (FA64 Only)

ITEM	QTY	PART NO.	DESCRIPTION
22	1	49T36288	Piston Cup (FA62 Only)
	1	49T37342	Piston Cup (FA64 Only)
23	1	12T36863	Piston O-ring (FA62 Only)
	1	12T36540	Piston O-ring (FA64 Only)
24	1	49T36287	Piston (FA62 Only)
	1	49T37341	Piston (FA64 Only)
25	7	49T36259	Friction Disc
26	8	27T36286	Wave Spring
27	6	49T36258	Spacer Disc
28	1	21T37085	Thrust Washer
29	1	02T36254	Output Bell Gear
30	1	10T37008	Bearing
31	2	21T29017	Thrust Washer
32	1	10T37009	Thrust Bearing
33	1	24T35480	Snap Ring
34	1	06T36295	Output Shaft "B" (FA62 Only)
	1	06T36253	Output Shaft "T" (FA62 Only)
	1	06T38823	Output Shaft "Q" (FA62 Only)
	1	06T39154	Output Shaft "R" (FA64 Only)
	1	06T37325	Output Shaft "T" (FA64 Only)
35	1	26T01627	Woodruff Key "B" (FA62 Only)
	1	25T37387	Cap Plug "T" (Both)
		25T35724	Cap Plug "Q" (FA62 Only)
		25T35520	Cap Plug "R" (FA64 Only)
36	1	10T21017	Bearing (FA62 Only)
	1	10T37229	Sealed Bearing (FA64 Only)
37	1	12T36751	Cover O-ring (FA62 Only)
38	1	See Table A	Flange/Seal Kit
39	4	19T39257	Capscrew
40	3	19T32740	Capscrew
41	1	25T21684	Pipe Plug
42	1	25T37702	Cap Plug
43	2	25T34029	Cap Plug
44	1	13T37386	Ford Transmission Gasket
45	1	19T37726	Storage Capscrew (FA64 Only)
N.S.	1	43TK3890	Lube Kit
N.S.	1	20TK4070	Stud Kit (FA62 Only)
	1	20TK4071	Stud Kit (FA64 Only)
N.S.	1	52TK3963	Instruction Packet
N.S.	1	13T37626	H.E.G.O. Sensor Gasket (FA64 Gas Engine Only)
N.S.	1	49TK4557	Pump Seal Kit (FA64 Only)

* Reverse Idler Gear, Idler Bearing, and Shim are sold as an assembly only. The Shim color code listed is a paint mark which is found on the edge of the Spacer.

TABLE A - Flange/Seal Kit (Item 38)

14TA5160	"B" Flange/Seal Kit (Includes 15T34576 Bearing Cap & 11T37790 Oil Seal)
14TA3997	"Q", "R", & "T" Flange/Seal Kit (Includes 14T39141 Hydraulic Flange & 11T37790 Oil Seal)
14T37781	"W" Hydraulic Flange (Requires 11T37790 Oil Seal)

FA62 SERIES DIMENSIONS IN INCHES (MM)

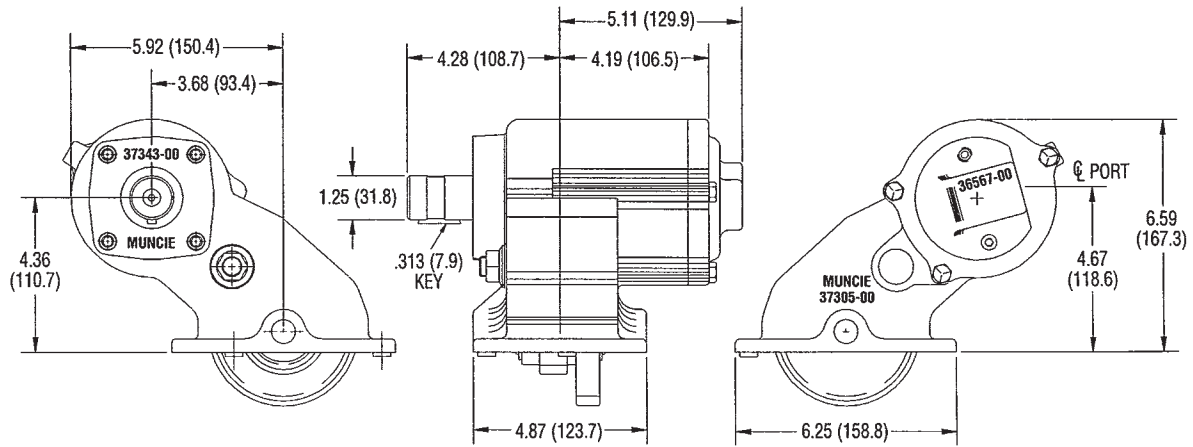

"B" OUTPUT SHAFT • 1-1/4 RD SHAFT, 5/16 KW • 4x2 APPLICATION

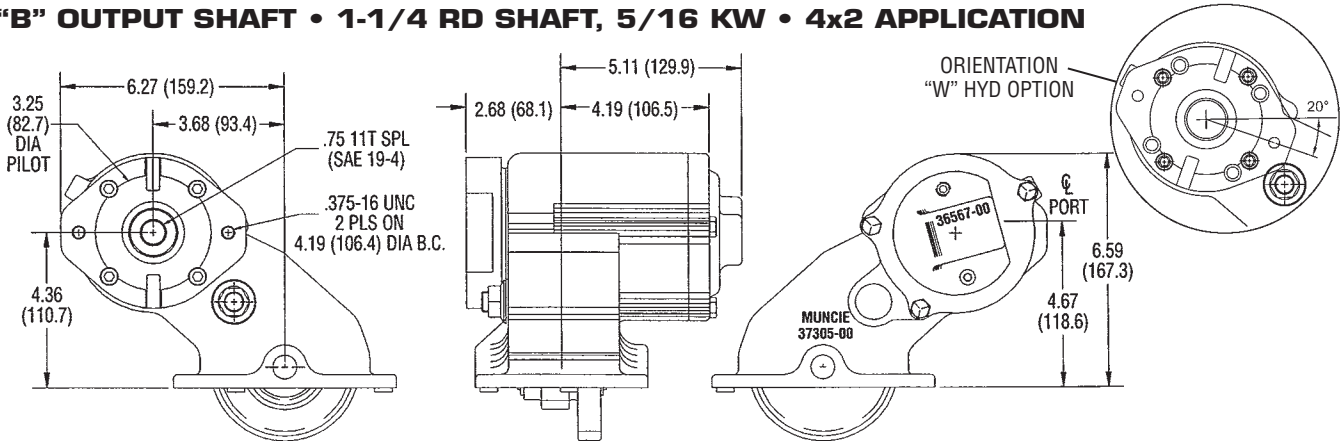

"T" or "W" HYDRAULIC MOUNT • SAE "A" PILOT, 3/4" 11T SPLINE SHAFT • 4x2 APPLICATION

FA64 SERIES DIMENSIONS IN INCHES (MM)

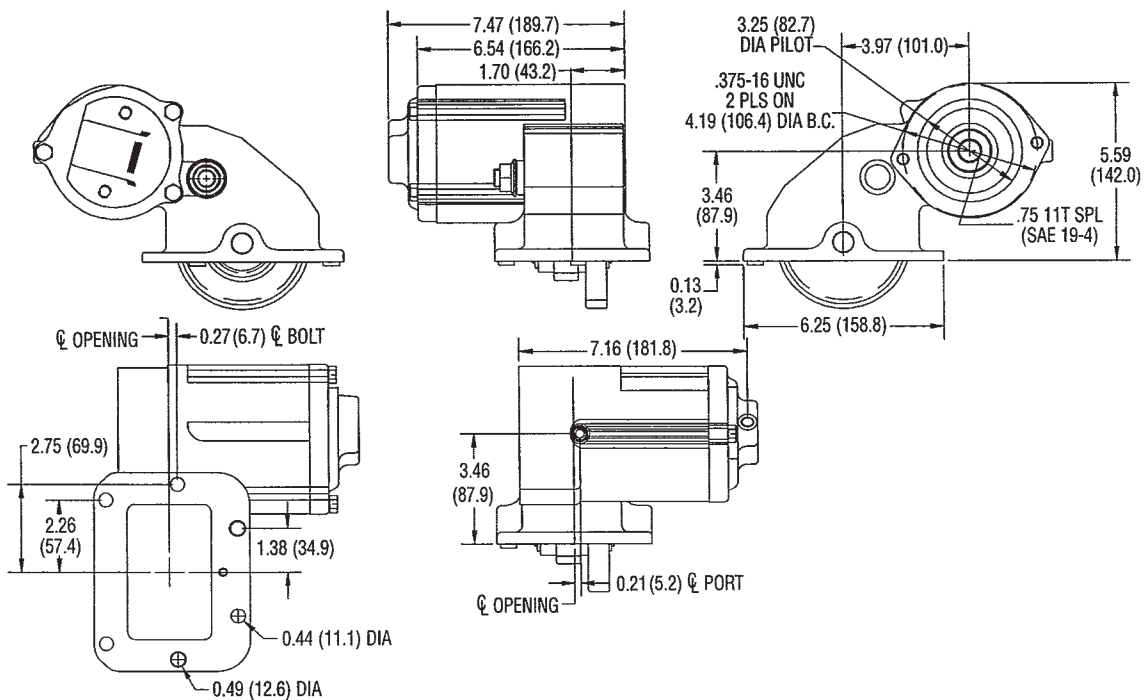

"T" HYDRAULIC MOUNT • SAE "A" PILOT, 3/4" 11T SPLINE SHAFT • 4x4 APPLICATION

TWO POSITION ONLY ROCKER SWITCH INSTALLATION (SHIFT CODE OPTION "Z")

1. The 2 position switch option does not change the way the harness or the rocker switch are installed. Refer to Steps 27 thru 41 of the FA Series PTO Owner's Manual (IN97-05) for the basic instructions. In this "Z" option the relay (PN 37T37621) is not used, and the socket remains on the harness unused.
2. When installing "Z" option the rocker switch note that the wire harness connector has a green wire, which should be positioned at the top; this will line up with the green light on the rocker switch (PN 30T37752).
3. Installation does not require any modification to the existing wiring harness.

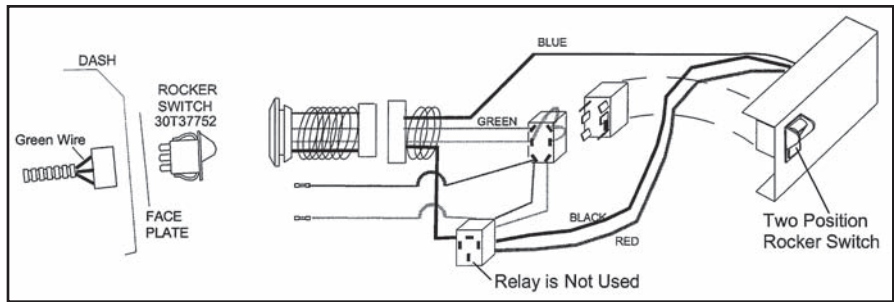

PTO INSTALLATION WITH FORD SUPPLIED APCM (DEALER OPTION ONLY)

1. Muncie harness PN 34T38267.
2. Connect the new harness as shown in the figure.
3. The standard rocker switch is not used, install a PTO indicator light in clear view of operator while seated in driver's seat. Order 36MK1210-A separately.

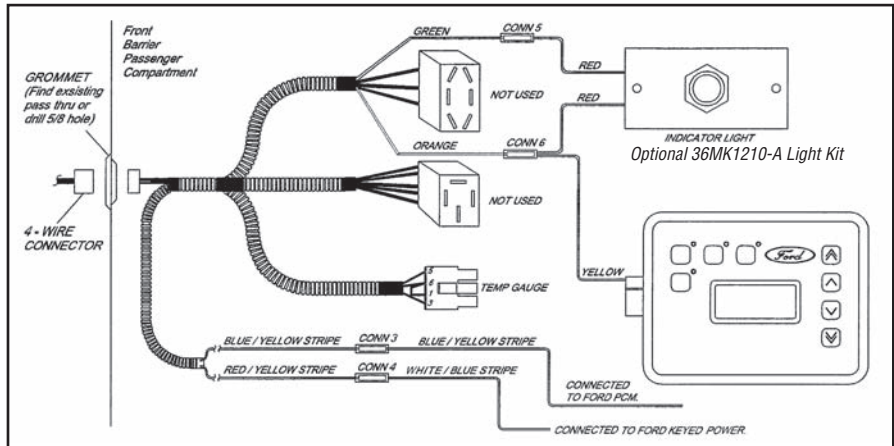

PTO INSTALLATION WITH SPD-1001A SPEED SWITCH

1. Make the PTO installation as described in Steps 1-41 of the FA Series PTO Owner's Manual (IN97-05).
2. Find the 4-wire connector on the Muncie PTO Harness and plug in the wire harness adapter 34T37753. The adapter is designed to assemble only in one direction.
3. Find the Red wire on this adapter harness which goes to the 4-wire connector and connect this wire to the SPD harness Red wire as shown in Diagram "A".
4. Connect the SPD Blue wire to the Green wire on the adapter harness as shown in Diagram "A".
5. The Ford supplied alternator should have a three wire connector plugged into it with a Light Green w/Red, an Orange w/Light Blue, and a White w/Black Stripe. The White w/Black is the wire to splice into for the Orange SPD wire. For 2002 model year, there is a clean tachometer output circuit located with body builder pass-through wires at left of steering column. Circuit #76, Light Green w/White trace, connect this to the Orange SPD wire.
6. Connect the Black SPD wire to a good ground at the fuse panel or battery (not to the cab).
7. Connect the White wire to the Overspeed light provided. Ground the other terminal of the Light.
8. Mount the SPD after making the calibration setting as described in the SPD installation manual (IN07-04).

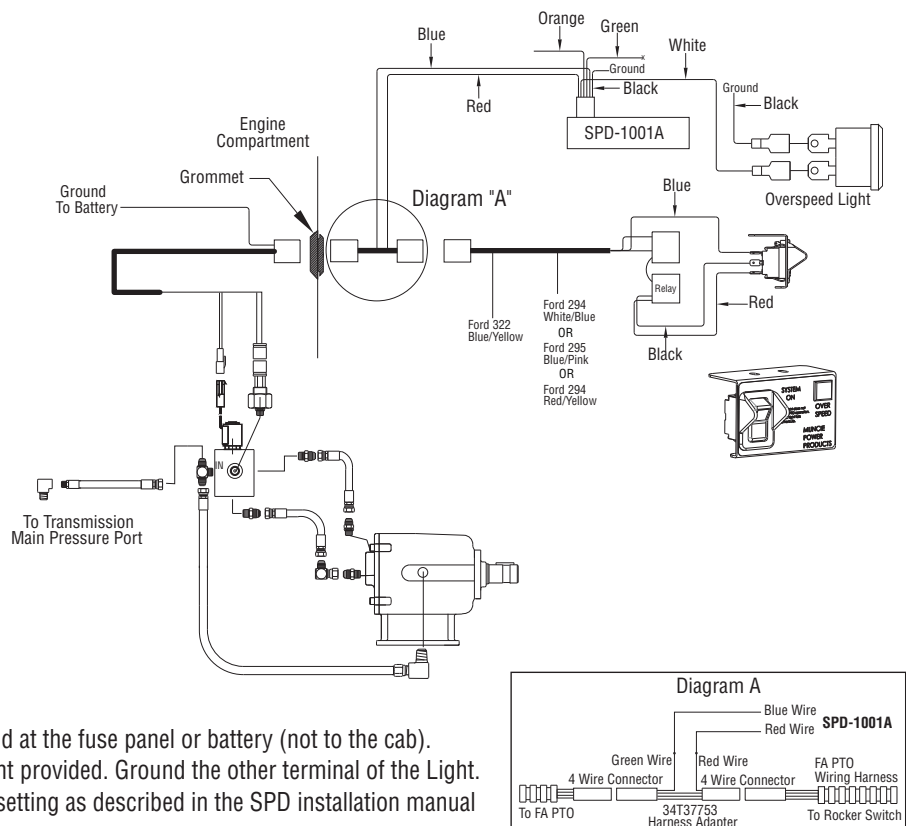

FA SERIES DISASSEMBLY AND REASSEMBLY (REFERENCE EXPLODED VIEW & PARTS LIST ON PAGES 2 & 3)

DISASSEMBLY PROCEDURE

INPUT GEAR

1. Remove set screw #6.
2. Drive idler shaft #5 from PTO.
3. Remove input gear #1 and bearings #2 and shim #3.

INTERMEDIATE GEAR

1. Remove the Input gear set first.
2. Remove hex nut #13 from idler shaft #7. Note position of slot on shaft.
3. Using brass hammer or soft drift drive the idler shaft #7 from the housing #18. Be careful not to damage shaft end.
4. Remove the idler gear #10 and bearings #8 from unit.

OUTPUT GEAR

1. On the FA62 remove the output bearing cover #39.
2. Remove the 3 cap screws #41 from closed bearing cover #14.
3. Using brass hammer or soft drift drive output shaft #34 from housing #18 in the direction of clutch pack. Closed bearing cover #14 will go with the shaft.
4. Remove the output bearing #36 if it stays in the housing #18 when you drive the shaft #34 out.
5. Remove the pipe plug #43 from the end cover #14. Remove plastic plug #45 or any fittings in cover.
6. Using a punch with a small enough end to fit through the holes in flat of bearing cover #14. Drive the bearing #17 from the cover.
7. Using a bearing puller remove the bearings #17 & #36 (if Req.) from both ends of the output shaft #34.
8. Remove snap ring #19 from piston end #22 & #24 of shaft by pushing in on piston cup #22 and using a snap ring tool to remove ring #19.
9. Slide piston #24 and piston cup #22 from the end of shaft #34.
10. Remove the fiction disks #25, spacer disks #27 and wave springs #26 from the shaft #34.
11. Remove snap ring #33 from gear side of bell gear #29 and remove gear #29, roller bearing #30, thrust washers #31 and thrust bearing #32.
12. Remove O-rings #4, #11, #12, & #15 from within housing #18.
13. Remove the O-rings #21 from the output shaft #34.

REASSEMBLY PROCEDURE

Lubricate O-rings prior to installation

1. Place the bell gear #29 thrust washer #28 on to output shaft #34.
2. Place bell gear roller bearing #30 on to shaft #34.
3. Place bell gear #29 over the roller bearing #30 and slide against the thrust washer #28.
4. Place thrust washer #31 on to shaft and against bell gear #29.
5. Place thrust bearing #32 against thrust washer #31.
6. Place 2nd thrust washer #31 against thrust bearing #32.
7. Install snap ring #33 on output shaft #34 to hold thrust bearing #32 and bell gear #29 in place.
8. Install clutch plates into bell gear #29 by placing wave spring #26 on first, then a friction disk #25, then a spacer plate #27 and continuing until you have placed eight wave springs, seven friction disks, and six spacer disks in bell gear. Finish with a wave spring.
9. Install O-rings #21 on to the output shaft #34.
10. Install piston O-ring #23 onto piston #24 and push piston #24 all the way into piston cup #22. Piston #24 has a hub on it and it should be facing out as piston is installed into piston cup #22.
11. Push the piston/piston cup assembly onto the output shaft #34.
12. Push down on piston cup assembly while installing #19 snap ring.
13. Install O-ring #15 and #16 into bearing cover #14.
14. Install Ball bearing #17 into rear cover #14.

15. Install output shaft assembly into bearing cover #14 by taping bearing onto shaft evenly.
16. Install output shaft assembly into housing #18. Install output bearing #36 (FA64 must use sealed bearing) into housing and onto output shaft #34.
17. Install the 3 bearing cover cap screws #41.
18. Install output bearing cover #39 on FA62 series w/4 cap screws #40.
19. Install pipe plug #43 into bearing cover. It doesn't matter which pipe port.

INSTALLING INTERMEDIATE SHAFT

Lubricate O-rings prior to installation.

Idler Gear is sold as an assembly only, and includes shim and bearings with pre-load established from the factory.

1. Proper shimming of the tapered roller bearings are critical. Be sure to purchase gear and bearing as an assembly from factory.
2. Place tapered roller bearings #8 into intermediate gear #10 with spacer #9 and place this setup into housing #18.
3. Place O-rings #11 & #12 into intermediate gear location of housing and grease.
4. When installing idler shaft #7 make sure the groove for clearance to input gear is positioned towards aperture opening. Draw a line perpendicular to middle of slot. This line should point to center of input idler shaft.
5. Insert intermediate idler shaft #7 through the large hole in side of housing into gear and bearing set and press into place. Do not use nut to pull idler shaft into place.
6. Using lock nut #13, tighten on idler shaft #7 and torque to 18-25 Ft.Lb.

INPUT GEAR ASS'Y

Lubricate O-rings prior to installation

1. Install input shaft ass'y O-rings #4. Place input bearings #2 into input gear #1.
2. Place input gear #1 into housing #18 so that gear clears internal interference on idler shaft #7 as described earlier in step 6 above.
3. Note location of set screw hole in housing and align hole in idler shaft as shaft is installed. Press idler shaft #5 from set screw side of housing #18 and install shaft #5 through the two input bearings #2. Then drive shaft in the opposite direction approximately 1" until shaft #5 is just below #2 bearing surface. Using one of the shims #3 find largest shim that will push in between bearing and housing without having to hit it into place. This should give a clearance between shim #3 and housing #18 of .002" to .006" loose.
4. When proper pre-load is established, continue installing idler shaft #5 until set screw #6 hole lines up.
5. Install set screw #6.

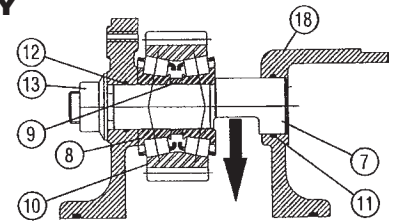

POINT SLOT TOWARDS IDLER SHAFT
ALIGN MIDDLE OF
SLOT WITH ϕ OF
INPUT IDLER SHAFT

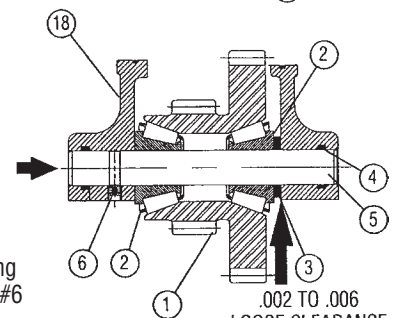
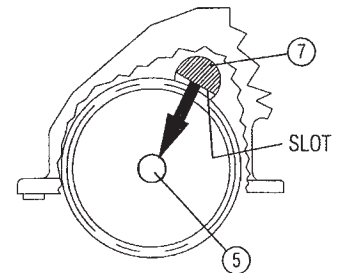

.002 TO .006
LOOSE CLEARANCE
LOCATE SHIM ON
THIS SIDE OF GEAR

FA SERIES STUD KITS

FA62 Series STUD KIT 20TK4070

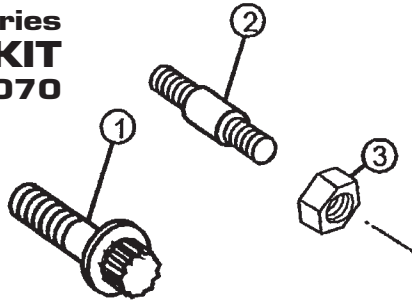

ITEM	QTY	PART NO.	DESCRIPTION
1	4	19T37727	12 pt. Metric Capscrew 25mm
2	2	20T37914	Alignment Stud
3	2	22T39282	Hex Nut

FA64 Series STUD KIT 20TK4071

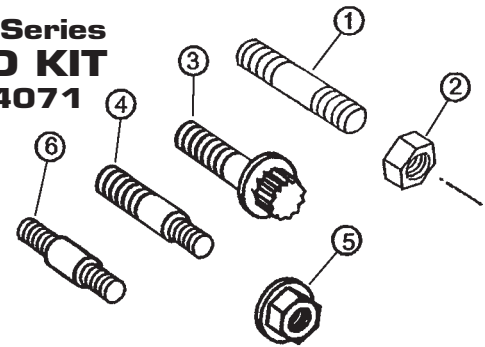

ITEM	QTY	PART NO.	DESCRIPTION
1	1	20M39045	10mm Stud
2	3	22T39282	Hex Nut
3	2	19T37727	12 pt. Metric Capscrew 30mm
4	1	20T37224	Step Stud
5	1	22T37605	Lock Nut
6	2	20T37914	Alignment Stud
N.S.	1	13T37626	Hego (O ₂) Sensor Gasket

FA SERIES SOLENOID VALVE

FA Series PTO Solenoid requires diode protection by vehicle manufacturer.

Included in this kit is a Jumper Connector which contains a diode. Install this into the Wire Connector prior to connecting to the PTO Activation Wiring Harness.

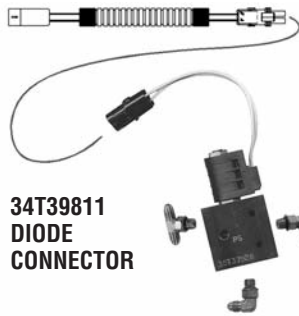

**34T39811
DIODE
CONNECTOR**

FA64 PUMP SEAL KIT - 49TA4557

FA64 SERIES PTO PUMP MODIFICATION INSTRUCTIONS

This kit is used to convert the FA64 series PTO coupled to a Muncie PF2 Series pump to a "Wet Spline" configuration.

The enclosed parts include an o-ring that goes on the pump pilot, and a brass ball that is to be driven into the weep hole of the pump flange. Perform this modification with the pump removed from the PTO:

1. Check the pump weep hole for a brass ball already inserted into hole (photo 2). If it is there, then discard ball provided.
2. The brass ball is slightly larger than the hole and will deform during the installation, effectively sealing the hole. Install this ball into the hole as shown (photos 1 and 2). A small hammer is required.
3. Place the o-ring around the pump pilot as shown in photo 3.



photo 1



photo 2



photo 3

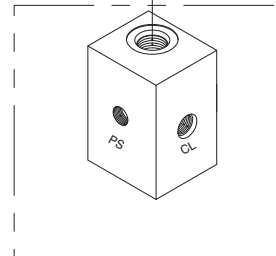
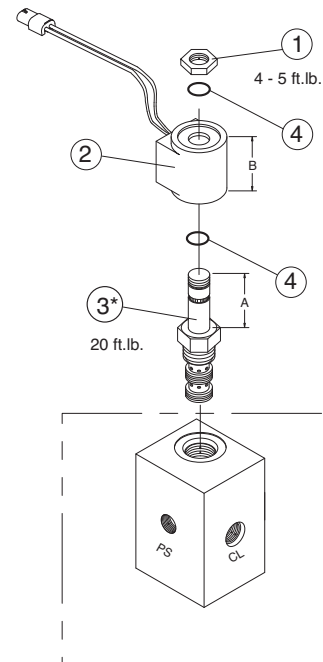

VALVE ASSEMBLY FOR ALL FA SERIES

ITEM	QTY	PART NO.	DESCRIPTION
1	1	35T37928	Valve Assembly, Manifold
2	1	35T36092	Valve Cartridge Assembly (Inc. Item 3, 4, 5 & Seals)
3	1	22T36498	Retaining Nut
4	1	37T36496	12V Coil
5	1	35T37997	Valve Stem
N.S.	1	12TK3902	Seal Kit



SP97-03 (Rev. 4-10) Printed in the U.S.A.
© Muncie Power Products, Inc. 2010

Muncie Power Products, Inc. Member of the Interpump Hydraulics Group
General Offices and Distribution Center • P.O. Box 548 • Muncie, IN 47308-0548
(765) 284-7721 • FAX (765) 284-6991 • E-mail info@munciepower.com
Web site <http://www.munciepower.com>

Drive Products, Exclusive Agents for Canada, ISO Certified by an Accredited Registrar

