

R.C.A. Victor Co., Inc.

Model: 66X2

Chassis:

Year: Pre 1948

Power:

Circuit:

IF:

Tubes:

Bands:

Resources

Riders Volume 18 - CHANGES 18-10

Riders Volume 15 - RCA 15-89

Riders Volume 15 - RCA 15-90

Riders Volume 15 - RCA 15-91

RCA 66X1, 66X2, RC-1038, 66X3, 66X4, 66X7, 66X8, 66X9, Chassis RC-1038A

These models are similar to Model 66X1, Chassis RC-1038, appearing on pages 15-39 through 15-91 of *Rider's Volume XV*. The following additions have been made to the parts list.

Stock No.	Description
72753	Plate—dial back plate complete with four (4) pulleys less dial for models 66X3, 66X4, 66X7, 66X8, 66X9
6134	Resistor—1200 ohms, 1 watt, (R11)
72514	Back—cabinet back for 66X7 and 66X9
72721	Back—cabinet back for 66X8
X1627	Baffle—baffle board and grill cloth for 66X7, 66X8, 66X9
Y1423	Cabinet—catalin (black) cabinet for 66X7
Y1408	Cabinet—catalin (red) cabinet for 66X8
Y1393	Cabinet—catalin (black and white) cabinet for 66X9
72822	Dial—glass dial scale for 66X3, 66X7, 66X8, 66X9
72678	Knob—control knob (black) for 66X7 and 66X9
71821	Knob—control knob (maroon) for 66X8
72295	Socket—phono

RCA 66X11, 66X12, 66X13, Chassis RC-1046C, RC-1046D, RC-1046E

These models are the same as Model 66X11, chassis RC-1046A, on pages 17-29 and 17-30 of *Rider's Volume XVII*, except for the following change. The capacitor C10 (tone-control circuit) which was connected

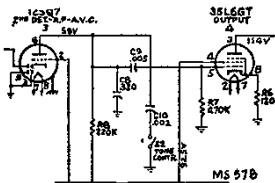

Capacitor C10 is here connected to the plate of the 12SQ7 a-f amplifier tube.

to the grid of the 35L6GT output tube, is now connected to the plate of the 12SQ7 a-f amplifier tube, as shown.

RCA 66X11, 66X12, 66X13, Chassis RC-1046C, RC-1046D, RC-1046E.

Second Production

These models are similar to Model 66X11, chassis RC-1046A, on pages 17-29 and 17-30 of *Rider's Volume XVII*. They incorporate the changes listed in the June 1948 issue of *SUCCESSFUL SERVICING*, in addition to the following changes. The parts list should be amended as follows:

CHASSIS ASSEMBLIES

- Change: 72896 Plate—to read 72896 Plate—dial back plate complete with drive cord pulleys for Model 66X11.
- Add: 72601 Plate—dial back plate complete with drive cord pulleys for Model 66X12.

MISCELLANEOUS

- Change: 73169 Back—to read 73169 Back—cabinet back for Model 66X13—walnut
- Add: 73278 Back—cabinet back for Model 66X13 mahogany
- 71893 Decal—trade mark decal

The stock number of the dial cord should be 72953 instead of 72913. This cord is supplied in 250 foot reels. Approximately 56 inches are required for the first

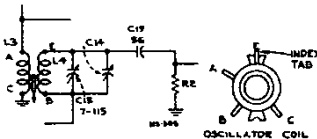

Oscillator Circuit RC-1046C, RC-1046E

Schematic otherwise identical to RC-1046. A-B except ant. tuning cond. C12 is 10-398 mmfd., only one dial lamp used on RC-1046E.

production and approximately 49 inches for the second production.

The differences between these various chassis are as follows. Chassis RC-1046C uses oscillator coil without capacity winding. L5. Capacitor C19 is used and a tuning capacitor without C16 is used. Two dial lamps type number 1490 are used. Chassis RC-1046E is the same as RC-1046C, except that only one dial lamp, Type 47, is used. For oscillator circuit see accompanying diagram.

- 73172 Capacitor—ceramic, 56µf (C19)
- 73163 Coil—Oscillator coil complete with adjustable core and stud (L3, L4)
- 73164 Capacitor—Variable tuning capacitor (C12, C13, C14, C15)

RCA 612V1, 612V3, AND 612V4

These models appear on pages 17-31 to 17-43 of *Rider's Volume XVII*. The alignment tabulation should be corrected to read as follows.

- Step No. 12—Repeat steps 10 and 11 for exact calibration.
- Step No. 18—Repeat steps 16 and 17 for maximum output.

On chassis RS-123, the electrolytic capacitor C1B has been changed from 15µf to 50µf.

RCA 612V1, 612V3, 612V4, Chassis RE-121

These models, appearing on pages 17-31 to 17-43 of *Rider's Volume XVII*, have been changed as follows. R36 is no longer connected to the junction of R35-R40-R22-R25. It is now connected to R37 and terminal #11 of S5. This change removes the plate voltage from V5 (6AU6) when the range switch is in the "Phono" position, and is illustrated here.

If the shielded lead of the power cable touches the speaker frame, noise will be caused. The power cable should be clamped in such a position to prevent contact with the speaker frame.

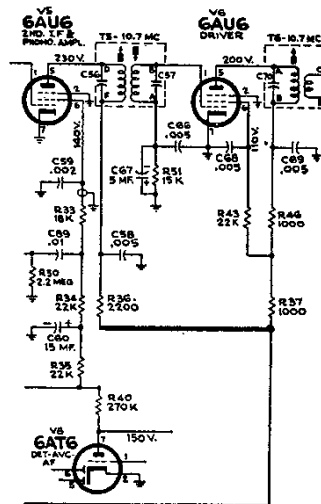

This new connection for R36 removes the plate voltage from V5 when the range switch is in the "Phono" position.

RCA Record Changer Model 960015

This model is shown on *RCD.CH. Page 15-11 of Rider's Volume XV*. If binding or freezing of turntable bearing occurs, the turntable shaft should be removed and polished with very fine emery cloth or crocus cloth. Clean off any bearing metal or foreign particles from the shaft, including the set-screw burr. Next, bevel the top edge of the top bearing slightly, with a knife or scraper. Clean the shaft and the bearing with carbon tetrachloride, removing oil and grease and being certain to clean out any chips which may have dropped into the bottom bearing. Lubricate all moving surfaces with a light coating of a very light-bodied grease.

If records do not separate properly and it is found necessary to adjust record slide actuating lever, proceed as follows:

1. Rotate separator shelf to 10" position.
2. Remove 10" landing adjustment bolt.
3. Press down on reject button and rotate turntable by hand in the normal direction until a "click" is heard (reject actuating slide latching).
4. Loosen set screws "C" and set record actuating lever 3/8 inch from bracket as indicated in Fig. 2 of service data.
5. Tighten set screws "G" and replace landing adjustment bolt.
6. Make necessary landing adjustment as described in service data.

NOTE: This method just described makes the set screw "G" more accessible and is therefore found more convenient. This method can be substituted for step No. 9 under Preliminary Adjustments.

RCA MFG. CO.

MODEL 3 66X1, 66X2, 66X3, 66X4,
66X9, Chassis RC-1038

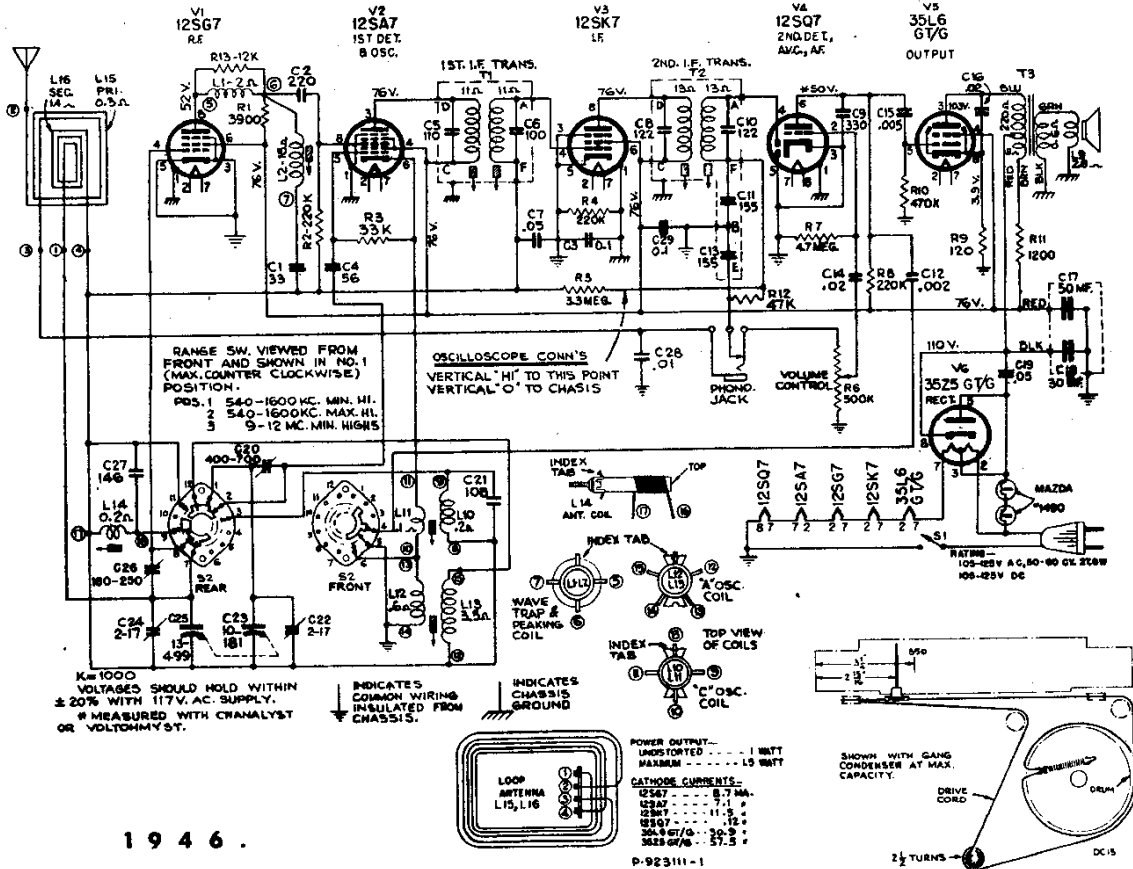

1946.

STOCK No.	DESCRIPTION	STOCK No.	DESCRIPTION
	CHASSIS ASSEMBLIES RC 1038		
30616	Capacitor—Mica, 33 mmf. (C1)	30931	Resistor—4.7 megohms, 1/4 watt (R7)
30622	Capacitor—Mica, 56 mmf. (C4)	*70467	Shaft—Tuning knob shaft
*71156	Capacitor—Ceramic, 108 mmf. (C21)	*71118	Shell—Protecting shell for loop spacing spring (2 required)
*71157	Capacitor—Ceramic, 146 mmf. (C27)	*71115	Socket—Lamp socket
*71121	Capacitor—Mica trimmer, 180-250 mmf. (C26)	37605	Socket—Tube socket
30636	Capacitor—Mica, 220 mmf. (C2)	*71120	Spacer—Tubular spacer to mount antenna loop (2 required)
30640	Capacitor—Mica, 330 mmf. (C9)	70390	Spring—Drive cord spring
*71113	Capacitor—Mica trimmer, 400-700 mmf. (C20)	*71119	Spring—Loop assembly spacing spring (2 required)
70601	Capacitor—Tubular, .002 mfd., 400 volts (C12)	*71112	Switch—Range and tone switch (S2)
70606	Capacitor—Tubular, .005 mfd., 400 volts (C15)	*71111	Transformer—Output transformer (L7, L8)
70610	Capacitor—Tubular, .01 mfd., 400 volts (C28)	71558	Transformer—First I.F. transformer (L3, L4, C5, C6)
70611	Capacitor—Tubular, .02 mfd., 400 volts (C14, C16)	70387	Transformer—Second I.F. transformer (L5, L6, C8, C10, C11, C13)
70615	Capacitor—Tubular, .05 mfd., 400 volts (C7, C19)	33726	Washer—"C" washer for tuning knob shaft
70617	Capacitor—Tubular, 0.1 mfd., 400 volts (C3, C29)		SPEAKER ASSEMBLY 922258-2
70408	Capacitor—Electrolytic, comprising 1 section of 50 mfd., 150 volts and 1 section of 30 mfd., 150 volts (C17, C18)	71058	Speaker—4" x 6" elliptical P.M. speaker complete with cone and voice coil
*71405	Coil—Antenna coil (L14)		NOTE: If stamping on speaker in instrument does not agree with above speaker number, order replacement parts by referring to model number of instrument, number stamped on speaker and full description of part required.
*71406	Coil—Oscillator coil—"A" band (L12, L13)		MISCELLANEOUS
*71408	Coil—Oscillator coil—"C" band (L10, L11)	*71835	Back—Cabinet back for Model 66X3
*71407	Coil—Wave trap (L1, L2)	*71122	Baffle—Speaker baffle assembly for 66X1 and 66X2
*71110	Condenser—Variable tuning condenser (C22, C23, C24, C25).	*71124	Clamp—Dial clamp for 66X1 and 66X2 (2 required)
38410	Control—Volume control and power switch (R6, S1)	*71131	Clamp—Dial clamp for 66X3 and 66X4
34662	Cord—Drive cord (approx. 51" overall length)	*71132	Dial—Glass dial scale
70384	Drum—Drive drum	*71127	Foot—Cabinet foot—walnut—for 66X1 (4 required)
70391	Insulator—Insulator for phono jack	*71128	Foot—Cabinet foot—ivory—for 66X2 (4 required)
*71114	Indicator—Station selector indicator	70473	Knob—Control knob (mottled walnut) for 66X1, 66X3, 66X4
*71116	Lamp—Dial lamp—Mazda 1490	70474	Knob—Control knob (ivory) for 66X2
*71117	Loop—Antenna loop (L15, L16)	*71126	Nut—Speed nut to fasten screen (4 required)
*71108	Plate—Dial back plate complete with four (4) pulleys less dial	*71125	Screen—Protective screen for hand grip for 66X1 and 66X2
36230	Pulley—Drive cord pulley	30900	Spring—Retaining spring for control knobs
30189	Resistor—120 ohms, 1/2 watt (R9)	*71130	Spring—Retaining spring for front strip for 66X1 and 66X2
30731	Resistor—1200 ohms, 1/2 watt (R11)	*71129	Strip—Finished strip for cabinet front for 66X1 and 66X2
30694	Resistor—3900 ohms, 1/2 watt (R1)		
30436	Resistor—12,000 ohms, 1/2 watt (R13)		
30685	Resistor—33,000 ohms, 1/2 watt (R3)		
30787	Resistor—47,000 ohms, 1/2 watt (R12)		
14583	Resistor—220,000 ohms, 1/2 watt (R2, R4, R8)		
30648	Resistor—470,000 ohms, 1/2 watt (R10)		
31417	Resistor—3.3 megohms, 1/2 watt (R5)		

*This is the first time this stock No. has appeared in service data.

"clarified schematics"

PAGE 15-90 RCA

MODELS 66X1, 66X2, 66X3, 66X4,
66X9, Chassis RC-1038

RCA MFG. CO.

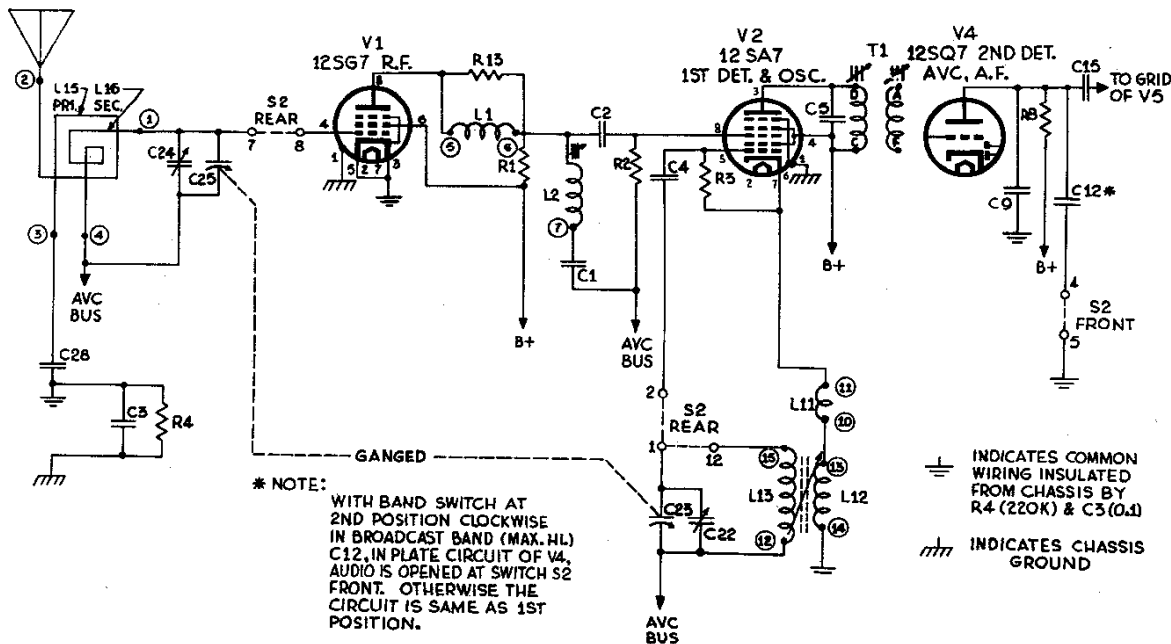

BAND-SWITCH SHOWN
AT 1ST POSITION.
BROADCAST BAND (MIN. HL.)
540 - 1600 KC.

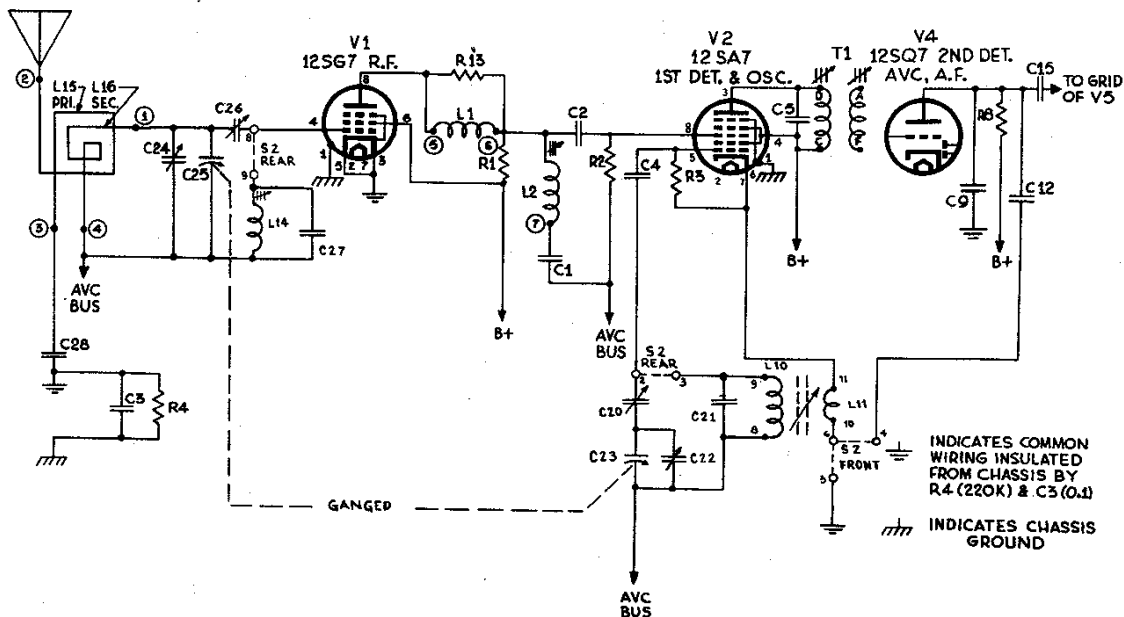

BAND-SWITCH SHOWN
AT 3RD POSITION CLOCKWISE
SHORT WAVE BAND (MIN. HL.)
9 - 12 MC.

RCA MFG. CO.

MODELS 66X1, 66X2, 66X3, 66X4,
66X9, Chassis RC-1038



66X9—(Plastic)

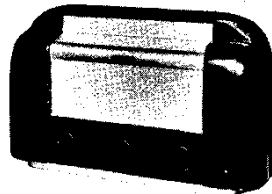

66X1—(Brown Plastic)

66X2—(Ivory Plastic)

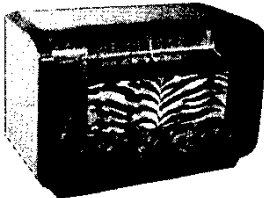

66X3—(Wood)

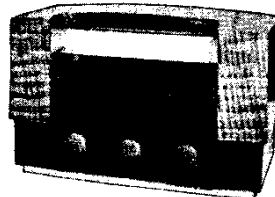

66X4—(Wood)

Specifications

Frequency Range	
Broadcast.....	540-1600 kc
Short Wave.....	9-12 mc
Intermediate Frequency.....	455 kc
Tube Complement	
(1) RCA-12SG7.....	R-F Amplifier
(2) RCA-12SA7.....	1st Det.—Osc.
(3) RCA-12SK7.....	I-F Amplifier
(4) RCA-12SQ7.....	2nd Det., A.V.C., and A-F Amplifier
(5) RCA-35L6-GT/G.....	Power Output
(6) RCA-35Z5-GT/G.....	Rectifier
Pilot Lamps.....	Mazda No. 1490, 3.2 volts
Power Output	
Undistorted.....	1.0 watts
Maximum.....	1.5 watts
Loudspeaker (922258-2)	
Size.....	4 x 6" elliptical P.M.
V.C. Impedance.....	3.4 ohms at 400 cycles
Power Supply Rating	
105-125 volts, AC, 50 or 60 cycles, or DC.....	27.6 watts

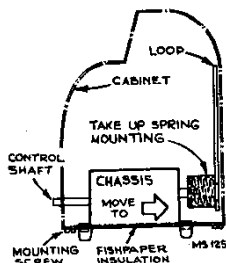

The construction of the cabinets for Models 66X1 and 2 makes it necessary to remove the chassis for replacing tubes. To do this, proceed as follows:

1. Remove the power plug from the service receptacle.
2. Remove control knobs.
3. Remove the six slotted screws around the edge of the metal base plate. (Do not remove the four feet from the base plate as this will separate the base plate from the chassis.)
4. Tilt the cabinet forward so that the bottom rear edge of the cabinet raises above base plate.
5. Hold the chassis with one hand while pushing the cabinet forward and upward to clear the control shafts.

Lead Dress

1. Dress all filament and power leads down to chassis and as far as possible from all audio grid and plate wiring.
2. Dress power cord back and away from C-14 (1st audio coupling condenser).
3. Dress C-14 toward 12SQ7 socket and away from the switch.
4. Dress C-16 (output by-pass condenser) down to chassis.
5. Dress blue lead from phono jack to volume control in air and away from output transformer.
6. Dress all leads and parts away from oscillator coils.
7. Dress C-2 (R.F. coupling condenser) back to chassis.
8. Avoid excessive lead lengths in C-27 (short wave fixed antenna coil) and short wave antenna coil.
9. Dress pilot light leads (above chassis) toward dial support and away from the 35Z5 tube.

Alignment Procedure

Test Oscillator.—Connect high side of test oscillator as shown in chart. Connect low side through a 0.1 mf. capacitor to common "B." Keep the output signal as low as possible to avoid A.V.C. action.

Output Meter.—Connect meter across speaker voice coil. Turn volume control to maximum clockwise position, station selector switch to broadcast maximum high position (pos. 2), for broadcast alignment and to position 3 for high frequency band.

Dial Pointer Adjustment.—Rotate tuning condenser fully counter-clockwise (plates fully meshed). Adjust indicator to 2 3/4 in. from end of backplate as indicated in drawing.

On models 66X1 and 2 the dial indicator is accessible for adjustment by removing the metal strip below the dial glass. (Lift and swing the top forward).

Calibration Scale.—The glass tuning dial may be easily removed from the cabinet and temporarily attached to the dial back plate.

Power Supply Polarity.—For operation on d-c, the power plug must be inserted in the outlet for correct polarity. If the set does not function, reverse the plug. On a-c, reversal of the plug may reduce hum.

Steps	Connect high side of the test oscillator to—	Tune test osc. to—	Turn radio dial to—	Adjust the following for maximum peak output		
1	Pin #4 (signal grid) 12SK7 IF tube in series with 0.1 mfd.	455 kc	Quiet point at 1600 kc end of the dial	T2† 2nd I-F trans.		
2	Pin #8 (signal grid) 12SA7 1st det. in series with 0.1 mfd.			T1 1st I-F trans.		
3	Antenna in series with 200 mmf.	1300 kc	1300 kc	L2 for minimum output (Wave trap)		
4				600 kc	600 kc	C22 (osc.) C24 (ant.)
5				600 kc	600 kc	L13 While rocking gang
6	Repeat steps 4 and 5.					
7	Antenna in series with 50 mmf.	9.5 mc.	9.5 mc.	C20 (Osc.)*		
8				11.8 mc.	11.8 mc.	C26 Ant. while rocking gang
9						L10 (Osc.)**
10				L14 while rocking gang		
11	Repeat steps 9 and 10.					

*If two peaks are obtained use minimum cap peak.

**If two peaks are obtained use minimum inductance peak.

†Do not repeat step No. 1.

