

Lustre^{*} Software Release 2.x

Operations Manual

Lustre^{*} Software Release 2.x: Operations Manual

Copyright © 2010, 2011 Oracle and/or its affiliates. (The original version of this Operations Manual without the Intel modifications.)

Copyright © 2011, 2017 Intel Corporation. (Intel modifications to the original version of this Operations Manual.)

Notwithstanding Intel's ownership of the copyright in the modifications to the original version of this Operations Manual, as between Intel and Oracle, Oracle and/or its affiliates retain sole ownership of the copyright in the unmodified portions of this Operations Manual.

Important Notice from Intel

INFORMATION IN THIS DOCUMENT IS PROVIDED IN CONNECTION WITH INTEL PRODUCTS. NO LICENSE, EXPRESS OR IMPLIED, BY ESTOPPEL OR OTHERWISE, TO ANY INTELLECTUAL PROPERTY RIGHTS IS GRANTED BY THIS DOCUMENT. EXCEPT AS PROVIDED IN INTEL'S TERMS AND CONDITIONS OF SALE FOR SUCH PRODUCTS, INTEL ASSUMES NO LIABILITY WHATSOEVER AND INTEL DISCLAIMS ANY EXPRESS OR IMPLIED WARRANTY, RELATING TO SALE AND/OR USE OF INTEL PRODUCTS INCLUDING LIABILITY OR WARRANTIES RELATING TO FITNESS FOR A PARTICULAR PURPOSE, MERCHANTABILITY, OR INFRINGEMENT OF ANY PATENT, COPYRIGHT OR OTHER INTELLECTUAL PROPERTY RIGHT.

A "Mission Critical Application" is any application in which failure of the Intel Product could result, directly or indirectly, in personal injury or death. SHOULD YOU PURCHASE OR USE INTEL'S PRODUCTS FOR ANY SUCH MISSION CRITICAL APPLICATION, YOU SHALL INDEMNIFY AND HOLD INTEL AND ITS SUBSIDIARIES, SUBCONTRACTORS AND AFFILIATES, AND THE DIRECTORS, OFFICERS, AND EMPLOYEES OF EACH, HARMLESS AGAINST ALL CLAIMS COSTS, DAMAGES, AND EXPENSES AND REASONABLE ATTORNEYS' FEES ARISING OUT OF, DIRECTLY OR INDIRECTLY, ANY CLAIM OF PRODUCT LIABILITY, PERSONAL INJURY, OR DEATH ARISING IN ANY WAY OUT OF SUCH MISSION CRITICAL APPLICATION, WHETHER OR NOT INTEL OR ITS SUBCONTRACTOR WAS NEGLIGENT IN THE DESIGN, MANUFACTURE, OR WARNING OF THE INTEL PRODUCT OR ANY OF ITS PARTS.

Intel may make changes to specifications and product descriptions at any time, without notice. Designers must not rely on the absence or characteristics of any features or instructions marked "reserved" or "undefined". Intel reserves these for future definition and shall have no responsibility whatsoever for conflicts or incompatibilities arising from future changes to them. The information here is subject to change without notice. Do not finalize a design with this information.

The products described in this document may contain design defects or errors known as errata which may cause the product to deviate from published specifications. Current characterized errata are available on request.

Contact your local Intel sales office or your distributor to obtain the latest specifications and before placing your product order.

Copies of documents which have an order number and are referenced in this document, or other Intel literature, may be obtained by calling 1-800-548-4725, or go to: <https://www.intel.com/content/www/us/en/design/resource-design-center.html>

Intel and the Intel logo are trademarks of Intel Corporation in the U.S. and/or other countries. Lustre is a registered trademark of Oracle Corporation.

*Other names and brands may be claimed as the property of others.

THE ORIGINAL LUSTRE 2.x FILESYSTEM: OPERATIONS MANUAL HAS BEEN MODIFIED: THIS OPERATIONS MANUAL IS A MODIFIED VERSION OF, AND IS DERIVED FROM, THE LUSTRE 2.0 FILESYSTEM: OPERATIONS MANUAL PUBLISHED BY ORACLE AND AVAILABLE AT [<http://www.lustre.org/>]. MODIFICATIONS (collectively, the "Modifications") HAVE BEEN MADE BY INTEL CORPORATION ("Intel"). ORACLE AND ITS AFFILIATES HAVE NOT REVIEWED, APPROVED, SPONSORED, OR ENDORSED THIS MODIFIED OPERATIONS MANUAL, OR ENDORSED INTEL, AND ORACLE AND ITS AFFILIATES ARE NOT RESPONSIBLE OR LIABLE FOR ANY MODIFICATIONS THAT INTEL HAS MADE TO THE ORIGINAL OPERATIONS MANUAL.

NOTHING IN THIS MODIFIED OPERATIONS MANUAL IS INTENDED TO AFFECT THE NOTICE PROVIDED BY ORACLE BELOW IN RESPECT OF THE ORIGINAL OPERATIONS MANUAL AND SUCH ORACLE NOTICE CONTINUES TO APPLY TO THIS MODIFIED OPERATIONS MANUAL EXCEPT FOR THE MODIFICATIONS; THIS INTEL NOTICE SHALL APPLY ONLY TO MODIFICATIONS MADE BY INTEL. AS BETWEEN YOU AND ORACLE: (I) NOTHING IN THIS INTEL NOTICE IS INTENDED TO AFFECT THE TERMS OF THE ORACLE NOTICE BELOW; AND (II) IN THE EVENT OF ANY CONFLICT BETWEEN THE TERMS OF THIS INTEL NOTICE AND THE TERMS OF THE ORACLE NOTICE, THE ORACLE NOTICE SHALL PREVAIL.

Your use of any Intel software shall be governed by separate license terms containing restrictions on use and disclosure and are protected by intellectual property laws.

The information contained herein is subject to change without notice and is not warranted to be error-free. If you find any errors, please report them to us in writing.

This work is licensed under a Creative Commons Attribution-Share Alike 3.0 United States License. To view a copy of this license and obtain more information about Creative Commons licensing, visit Creative Commons Attribution-Share Alike 3.0 United States [<http://creativecommons.org/licenses/by-sa/3.0/us/>] or send a letter to Creative Commons, 171 2nd Street, Suite 300, San Francisco, California 94105, USA.

Important Notice from Oracle

This software and related documentation are provided under a license agreement containing restrictions on use and disclosure and are protected by intellectual property laws. Except as expressly permitted in your license agreement or allowed by law, you may not use, copy, reproduce, translate, broadcast, modify, license, transmit, distribute, exhibit, perform, publish, or display any part, in any form, or by any means. Reverse engineering, disassembly, or decompilation of this software, unless required by law for interoperability, is prohibited.

The information contained herein is subject to change without notice and is not warranted to be error-free. If you find any errors, please report them to us in writing.

If this is software or related software documentation that is delivered to the U.S. Government or anyone licensing it on behalf of the U.S. Government, the following notice is applicable:

U.S. GOVERNMENT RIGHTS. Programs, software, databases, and related documentation and technical data delivered to U.S. Government customers are "commercial computer software" or "commercial technical data" pursuant to the applicable Federal Acquisition Regulation and agency-specific supplemental regulations. As such, the use, duplication, disclosure, modification, and adaptation shall be subject to the restrictions and license terms set forth in the applicable Government contract, and, to the extent applicable by the terms of the Government contract, the additional rights set forth in FAR 52.227-19, Commercial Computer Software License (December 2007). Oracle America, Inc., 500 Oracle Parkway, Redwood City, CA 94065.

This software or hardware is developed for general use in a variety of information management applications. It is not developed or intended for use in any inherently dangerous applications, including applications which may create a risk of personal injury. If you use this software or hardware in dangerous applications, then you shall be responsible to take all appropriate fail-safe, backup, redundancy, and other measures to ensure its safe use. Oracle Corporation and its affiliates disclaim any liability for any damages caused by use of this software or hardware in dangerous applications.

Oracle and Java are registered trademarks of Oracle and/or its affiliates. Other names may be trademarks of their respective owners.

AMD, Opteron, the AMD logo, and the AMD Opteron logo are trademarks or registered trademarks of Advanced Micro Devices. Intel and Intel Xeon are trademarks or registered trademarks of Intel Corporation. All SPARC trademarks are used under license and are trademarks or registered trademarks of SPARC International, Inc. UNIX is a registered trademark licensed through X/Open Company, Ltd.

This software or hardware and documentation may provide access to or information on content, products, and services from third parties. Oracle Corporation and its affiliates are not responsible for and expressly disclaim all warranties of any kind with respect to third-party content, products, and services. Oracle Corporation and its affiliates will not be responsible for any loss, costs, or damages incurred due to your access to or use of third-party content, products, or services.

Copyright © 2011, Oracle et/ou ses affiliés. Tous droits réservés.

Ce logiciel et la documentation qui l'accompagne sont protégés par les lois sur la propriété intellectuelle. Ils sont concédés sous licence et soumis à des restrictions d'utilisation et de divulgation. Sauf disposition de votre contrat de licence ou de la loi, vous ne pouvez pas copier, reproduire, traduire, diffuser, modifier, breveter, transmettre, distribuer, exposer, exécuter, publier ou afficher le logiciel, même partiellement, sous quelque forme et par quelque procédé que ce soit. Par ailleurs, il est interdit de procéder à toute ingénierie inverse du logiciel, de le désassembler ou de le décompiler, excepté à des fins d'interopérabilité avec des logiciels tiers ou tel que prescrit par la loi.

Les informations fournies dans ce document sont susceptibles de modification sans préavis. Par ailleurs, Oracle Corporation ne garantit pas qu'elles soient exemptes d'erreurs et vous invite, le cas échéant, à lui en faire part par écrit.

Si ce logiciel, ou la documentation qui l'accompagne, est concédé sous licence au Gouvernement des Etats-Unis, ou à toute entité qui délivre la licence de ce logiciel ou l'utilise pour le compte du Gouvernement des Etats-Unis, la notice suivante s'applique :

U.S. GOVERNMENT RIGHTS. Programs, software, databases, and related documentation and technical data delivered to U.S. Government customers are "commercial computer software" or "commercial technical data" pursuant to the applicable Federal Acquisition Regulation and agency-specific supplemental regulations. As such, the use, duplication, disclosure, modification, and adaptation shall be subject to the restrictions and license terms set forth in the applicable Government contract, and, to the extent applicable by the terms of the Government contract, the additional rights set forth in FAR 52.227-19, Commercial Computer Software License (December 2007). Oracle America, Inc., 500 Oracle Parkway, Redwood City, CA 94065.

Ce logiciel ou matériel a été développé pour un usage général dans le cadre d'applications de gestion des informations. Ce logiciel ou matériel n'est pas conçu ni n'est destiné à être utilisé dans des applications à risque, notamment dans des applications pouvant causer des dommages corporels. Si vous utilisez ce logiciel ou matériel dans le cadre d'applications dangereuses, il est de votre responsabilité de prendre toutes les mesures de secours, de sauvegarde, de redondance et autres mesures nécessaires à son utilisation dans des conditions optimales de sécurité. Oracle Corporation et ses affiliés déclinent toute responsabilité quant aux dommages causés par l'utilisation de ce logiciel ou matériel pour ce type d'applications.

Oracle et Java sont des marques déposées d'Oracle Corporation et/ou de ses affiliés. Tout autre nom mentionné peut correspondre à des marques appartenant à d'autres propriétaires qu'Oracle.

AMD, Opteron, le logo AMD et le logo AMD Opteron sont des marques ou des marques déposées d'Advanced Micro Devices. Intel et Intel Xeon sont des marques ou des marques déposées d'Intel Corporation. Toutes les marques SPARC sont utilisées sous licence et sont des marques ou des marques déposées de SPARC International, Inc. UNIX est une marque déposée concédée sous licence par X/Open Company, Ltd.

Ce logiciel ou matériel et la documentation qui l'accompagne peuvent fournir des informations ou des liens donnant accès à des contenus, des produits et des services émanant de tiers. Oracle Corporation et ses affiliés déclinent toute responsabilité ou garantie expresse quant aux contenus, produits ou services émanant de tiers. En aucun cas, Oracle Corporation et ses affiliés ne sauraient être tenus pour responsables des pertes subies, des coûts occasionnés ou des dommages causés par l'accès à des contenus, produits ou services tiers, ou à leur utilisation.

This work is licensed under a Creative Commons Attribution-Share Alike 3.0 United States License. To view a copy of this license and obtain more information about Creative Commons licensing, visit Creative Commons Attribution-Share Alike 3.0 United States [<http://creativecommons.org/licenses/by-sa/3.0/us>] or send a letter to Creative Commons, 171 2nd Street, Suite 300, San Francisco, California 94105, USA.

Table of Contents

Preface	xxiii
1. About this Document	xxiii
1.1. UNIX* Commands	xxiii
1.2. Shell Prompts	xxiii
1.3. Related Documentation	xxiv
1.4. Documentation and Support	xxiv
2. Revisions	xxiv
I. Introducing the Lustre* File System	1
1. Understanding Lustre Architecture	3
1.1. What a Lustre File System Is (and What It Isn't)	3
1.1.1. Lustre Features	3
1.2. Lustre Components	6
1.2.1. Management Server (MGS)	7
1.2.2. Lustre File System Components	7
1.2.3. Lustre Networking (LNet)	8
1.2.4. Lustre Cluster	8
1.3. Lustre File System Storage and I/O	9
1.3.1. Lustre File System and Striping	11
2. Understanding Lustre Networking (LNet)	14
2.1. Introducing LNet	14
2.2. Key Features of LNet	14
2.3. Lustre Networks	14
2.4. Supported Network Types	15
3. Understanding Failover in a Lustre File System	16
3.1. What is Failover?	16
3.1.1. Failover Capabilities	16
3.1.2. Types of Failover Configurations	17
3.2. Failover Functionality in a Lustre File System	17
3.2.1. MDT Failover Configuration (Active/Passive)	18
3.2.2. MDT Failover Configuration (Active/Active)	18
3.2.3. OST Failover Configuration (Active/Active)	19
II. Installing and Configuring Lustre	21
4. Installation Overview	24
4.1. Steps to Installing the Lustre Software	24
5. Determining Hardware Configuration Requirements and Formatting Options	25
5.1. Hardware Considerations	25
5.1.1. MGT and MDT Storage Hardware Considerations	26
5.1.2. OST Storage Hardware Considerations	27
5.2. Determining Space Requirements	27
5.2.1. Determining MGT Space Requirements	28
5.2.2. Determining MDT Space Requirements	28
5.2.3. Determining OST Space Requirements	29
5.3. Setting ldiskfs File System Formatting Options	29
5.3.1. Setting Formatting Options for an ldiskfs MDT	30
5.3.2. Setting Formatting Options for an ldiskfs OST	31
5.4. File and File System Limits	31
5.5. Determining Memory Requirements	35
5.5.1. Client Memory Requirements	35
5.5.2. MDS Memory Requirements	35
5.5.3. OSS Memory Requirements	36
5.6. Implementing Networks To Be Used by the Lustre File System	37

6. Configuring Storage on a Lustre File System	39
6.1. Selecting Storage for the MDT and OSTs	39
6.1.1. Metadata Target (MDT)	39
6.1.2. Object Storage Server (OST)	39
6.2. Reliability Best Practices	40
6.3. Performance Tradeoffs	40
6.4. Formatting Options for Ldiskfs RAID Devices	40
6.4.1. Computing file system parameters for mkfs	41
6.4.2. Choosing Parameters for an External Journal	41
6.5. Connecting a SAN to a Lustre File System	42
7. Setting Up Network Interface Bonding	43
7.1. Network Interface Bonding Overview	43
7.2. Requirements	43
7.3. Bonding Module Parameters	44
7.4. Setting Up Bonding	45
7.4.1. Examples	47
7.5. Configuring a Lustre File System with Bonding	48
7.6. Bonding References	48
8. Installing the Lustre Software	50
8.1. Preparing to Install the Lustre Software	50
8.1.1. Software Requirements	50
8.1.2. Environmental Requirements	52
8.2. Lustre Software Installation Procedure	52
9. Configuring Lustre Networking (LNet)	55
9.1. Configuring LNet via <code>lnetctl</code>	L 2.7 55
9.1.1. Configuring LNet	56
9.1.2. Displaying Global Settings	56
9.1.3. Adding, Deleting and Showing Networks	56
9.1.4. Manual Adding, Deleting and Showing Peers	L 2.10 58
9.1.5. Dynamic Peer Discovery	L 2.11 60
9.1.6. Adding, Deleting and Showing routes	61
9.1.7. Enabling and Disabling Routing	62
9.1.8. Showing routing information	62
9.1.9. Configuring Routing Buffers	62
9.1.10. Asymmetrical Routes	L 2.13 63
9.1.11. Importing YAML Configuration File	64
9.1.12. Exporting Configuration in YAML format	64
9.1.13. Showing LNet Traffic Statistics	64
9.1.14. YAML Syntax	64
9.2. Overview of LNet Module Parameters	66
9.2.1. Using a Lustre Network Identifier (NID) to Identify a Node	66
9.3. Setting the LNet Module networks Parameter	67
9.3.1. Multihome Server Example	68
9.4. Setting the LNet Module ip2nets Parameter	68
9.5. Setting the LNet Module routes Parameter	70
9.5.1. Routing Example	70
9.6. Testing the LNet Configuration	70
9.7. Configuring the Router Checker	71
9.8. Best Practices for LNet Options	72
9.8.1. Escaping commas with quotes	72
9.8.2. Including comments	72
10. Configuring a Lustre File System	73
10.1. Configuring a Simple Lustre File System	73
10.1.1. Simple Lustre Configuration Example	76

10.2. Additional Configuration Options	81
10.2.1. Scaling the Lustre File System	81
10.2.2. Changing Striping Defaults	81
10.2.3. Using the Lustre Configuration Utilities	82
11. Configuring Failover in a Lustre File System	83
11.1. Setting Up a Failover Environment	83
11.1.1. Selecting Power Equipment	83
11.1.2. Selecting Power Management Software	83
11.1.3. Selecting High-Availability (HA) Software	84
11.2. Preparing a Lustre File System for Failover	84
11.3. Administering Failover in a Lustre File System	85
III. Administering Lustre	86
12. Monitoring a Lustre File System	94
12.1. Lustre Changelogs	94
12.1.1. Working with Changelogs	95
12.1.2. Changelog Examples	96
12.1.3. Audit with Changelogs	L 2.11 98
12.2. Lustre Jobstats	100
12.2.1. How Jobstats Works	101
12.2.2. Enable/Disable Jobstats	102
12.2.3. Check Job Stats	103
12.2.4. Clear Job Stats	104
12.2.5. Configure Auto-cleanup Interval	104
12.2.6. Identifying Top Jobs	L 2.14 105
12.3. Lustre Monitoring Tool (LMT)	105
12.4. CollectL	105
12.5. Other Monitoring Options	105
13. Lustre Operations	107
13.1. Mounting by Label	107
13.2. Starting Lustre	107
13.3. Mounting a Server	108
13.4. Stopping the Filesystem	108
13.5. Unmounting a Specific Target on a Server	110
13.6. Specifying Failout/Failover Mode for OSTs	110
13.7. Handling Degraded OST RAID Arrays	111
13.8. Running Multiple Lustre File Systems	111
13.9. Creating a sub-directory on a specific MDT	113
13.10. Creating a directory striped across multiple MDTs	L 2.8 114
13.10.1. Directory creation by space/inode usage	L 2.13 114
13.10.2. Filesystem-wide default directory striping	L 2.14 115
13.11. Default Dir Stripe Policy	116
13.12. Setting and Retrieving Lustre Parameters	116
13.12.1. Setting Tunable Parameters with <code>mkfs.lustre</code>	117
13.12.2. Setting Parameters with <code>tunefs.lustre</code>	117
13.12.3. Setting Parameters with <code>lctl</code>	117
13.13. Specifying NIDs and Failover	120
13.14. Erasing a File System	121
13.15. Reclaiming Reserved Disk Space	122
13.16. Replacing an Existing OST or MDT	122
13.17. Identifying To Which Lustre File an OST Object Belongs	122
14. Lustre Maintenance	124
14.1. Working with Inactive OSTs	124
14.2. Finding Nodes in the Lustre File System	125
14.3. Mounting a Server Without Lustre Service	125

14.4. Regenerating Lustre Configuration Logs	126
14.5. Changing a Server NID	127
14.6. Clearing configuration	L 2.11 128
14.7. Adding a New MDT to a Lustre File System	129
14.8. Adding a New OST to a Lustre File System	129
14.9. Removing and Restoring MDTs and OSTs	130
14.9.1. Removing an MDT from the File System	131
14.9.2. Working with Inactive MDTs	131
14.9.3. Removing an OST from the File System	131
14.9.4. Backing Up OST Configuration Files	133
14.9.5. Restoring OST Configuration Files	134
14.9.6. Returning a Deactivated OST to Service	135
14.10. Aborting Recovery	135
14.11. Determining Which Machine is Serving an OST	135
14.12. Changing the Address of a Failover Node	136
14.13. Separate a combined MGS/MDT	136
14.14. Set an MDT to read-only	L 2.13 137
14.15. Tune Fallocate for ldiskfs	L 2.14 137
15. Managing Lustre Networking (LNet)	139
15.1. Updating the Health Status of a Peer or Router	139
15.2. Starting and Stopping LNet	139
15.2.1. Starting LNet	139
15.2.2. Stopping LNet	140
15.3. Hardware Based Multi-Rail Configurations with LNet	141
15.4. Load Balancing with an InfiniBand* Network	141
15.4.1. Setting Up lustre.conf for Load Balancing	141
15.5. Dynamically Configuring LNet Routes	143
15.5.1. lustre_routes_config	143
15.5.2. lustre_routes_conversion	144
15.5.3. Route Configuration Examples	144
16. LNet Software Multi-Rail	L 2.10 145
16.1. Multi-Rail Overview	145
16.2. Configuring Multi-Rail	145
16.2.1. Configure Multiple Interfaces on the Local Node	145
16.2.2. Deleting Network Interfaces	147
16.2.3. Adding Remote Peers that are Multi-Rail Capable	147
16.2.4. Deleting Remote Peers	148
16.3. Notes on routing with Multi-Rail	149
16.3.1. Multi-Rail Cluster Example	149
16.3.2. Utilizing Router Resiliency	151
16.3.3. Mixed Multi-Rail/Non-Multi-Rail Cluster	151
16.4. Multi-Rail Routing with LNet Health	L 2.13 152
16.4.1. Configuration	152
16.4.2. Router Health	153
16.4.3. Discovery	153
16.4.4. Route Aliveness Criteria	153
16.5. LNet Health	L 2.12 154
16.5.1. Health Value	154
16.5.2. Failure Types and Behavior	154
16.5.3. User Interface	155
16.5.4. Displaying Information	157
16.5.5. Initial Settings Recommendations	159
17. Upgrading a Lustre File System	161
17.1. Release Interoperability and Upgrade Requirements	161

17.2. Upgrading to Lustre Software Release 2.x (Major Release)	161
17.3. Upgrading to Lustre Software Release 2.x.y (Minor Release)	165
18. Backing Up and Restoring a File System	167
18.1. Backing up a File System	167
18.1.1. Lustre_rsync	168
18.2. Backing Up and Restoring an MDT or OST (ldiskfs Device Level)	170
18.3. Backing Up an OST or MDT (Backend File System Level)	171
18.3.1. Backing Up an OST or MDT (Backend File System Level)	L 2.11 171
18.3.2. Backing Up an OST or MDT	172
18.4. Restoring a File-Level Backup	174
18.5. Using LVM Snapshots with the Lustre File System	176
18.5.1. Creating an LVM-based Backup File System	176
18.5.2. Backing up New/Changed Files to the Backup File System	178
18.5.3. Creating Snapshot Volumes	178
18.5.4. Restoring the File System From a Snapshot	178
18.5.5. Deleting Old Snapshots	180
18.5.6. Changing Snapshot Volume Size	180
18.6. Migration Between ZFS and ldiskfs Target Filesystems	L 2.11 180
18.6.1. Migrate from a ZFS to an ldiskfs based filesystem	180
18.6.2. Migrate from an ldiskfs to a ZFS based filesystem	180
19. Managing File Layout (Striping) and Free Space	182
19.1. How Lustre File System Striping Works	182
19.2. Lustre File Layout (Striping) Considerations	182
19.2.1. Choosing a Stripe Size	183
19.3. Setting the File Layout/Striping Configuration (<code>lfs setstripe</code>)	184
19.3.1. Specifying a File Layout (Striping Pattern) for a Single File	185
19.3.2. Setting the Striping Layout for a Directory	186
19.3.3. Setting the Striping Layout for a File System	186
19.3.4. Per File System Stripe Count Limit	186
19.3.5. Creating a File on a Specific OST	187
19.4. Retrieving File Layout/Striping Information (<code>getstripe</code>)	187
19.4.1. Displaying the Current Stripe Size	187
19.4.2. Inspecting the File Tree	188
19.4.3. Locating the MDT for a remote directory	188
19.5. Progressive File Layout(PFL)	L 2.10 188
19.5.1. <code>lfs setstripe</code>	190
19.5.2. <code>lfs migrate</code>	197
19.5.3. <code>lfs getstripe</code>	201
19.5.4. <code>lfs find</code>	205
19.6. Self-Extending Layout (SEL)	L 2.13 206
19.6.1. <code>lfs setstripe</code>	207
19.6.2. <code>lfs getstripe</code>	209
19.6.3. <code>lfs find</code>	216
19.7. Foreign Layout	L 2.13 217
19.7.1. <code>lfs set[dir]stripe</code>	217
19.7.2. <code>lfs get[dir]stripe</code>	218
19.7.3. <code>lfs find</code>	218
19.8. Managing Free Space	219
19.8.1. Checking File System Free Space	219
19.8.2. Stripe Allocation Methods	221
19.8.3. Adjusting the Weighting Between Free Space and Location	222
19.9. Lustre Striping Internals	222
20. Data on MDT (DoM)	L 2.11 224
20.1. Introduction to Data on MDT (DoM)	224

20.2. User Commands	224
20.2.1. lfs setstripe for DoM files	224
20.2.2. Setting a default DoM layout to an existing directory	226
20.2.3. DoM Stripe Size Restrictions	228
20.2.4. lfs getstripe for DoM files	228
20.2.5. lfs find for DoM files	229
20.2.6. The dom_stripesize parameter	230
20.2.7. Disable DoM	231
21. Lazy Size on MDT (LSoM)	L 2.12 232
21.1. Introduction to Lazy Size on MDT (LSoM)	232
21.2. Enable LSoM	232
21.3. User Commands	233
21.3.1. lfs getsom for LSoM data	233
21.3.2. Syncing LSoM data	233
22. File Level Redundancy (FLR)	L 2.11 235
22.1. Introduction	235
22.2. Operations	235
22.2.1. Creating a Mirrored File or Directory	235
22.2.2. Extending a Mirrored File	240
22.2.3. Splitting a Mirrored File	244
22.2.4. Resynchronizing out-of-sync Mirrored File(s)	249
22.2.5. Verifying Mirrored File(s)	253
22.2.6. Finding Mirrored File(s)	255
22.3. Interoperability	256
23. Managing the File System and I/O	258
23.1. Handling Full OSTs	258
23.1.1. Checking OST Space Usage	258
23.1.2. Disabling creates on a Full OST	259
23.1.3. Migrating Data within a File System	259
23.1.4. Returning an Inactive OST Back Online	259
23.1.5. Migrating Metadata within a Filesystem	259
23.2. Creating and Managing OST Pools	261
23.2.1. Working with OST Pools	262
23.2.2. Tips for Using OST Pools	264
23.3. Adding an OST to a Lustre File System	264
23.4. Performing Direct I/O	265
23.4.1. Making File System Objects Immutable	265
23.5. Other I/O Options	265
23.5.1. Lustre Checksums	265
23.5.2. PtlRPC Client Thread Pool	266
24. Lustre File System Failover and Multiple-Mount Protection	268
24.1. Overview of Multiple-Mount Protection	268
24.2. Working with Multiple-Mount Protection	268
25. Configuring and Managing Quotas	270
25.1. Working with Quotas	270
25.2. Enabling Disk Quotas	270
25.2.1. Quota Verification	272
25.3. Quota Administration	273
25.4. Default Quota	L 2.12 275
25.4.1. Usage	275
25.5. Quota Allocation	277
25.6. Quotas and Version Interoperability	278
25.7. Granted Cache and Quota Limits	278
25.8. Lustre Quota Statistics	279

25.8.1. Interpreting Quota Statistics	280
25.9. Pool Quotas	L 2.14 280
25.9.1. DOM and MDT pools	281
25.9.2. Lfs quota/setquota options to setup quota pools	281
25.9.3. Quota pools interoperability	281
25.9.4. Pool Quotas Hard Limit setup example	281
25.9.5. Pool Quotas Soft Limit setup example	282
26. Hierarchical Storage Management (HSM)	L 2.5 283
26.1. Introduction	283
26.2. Setup	283
26.2.1. Requirements	283
26.2.2. Coordinator	284
26.2.3. Agents	284
26.3. Agents and copytool	284
26.3.1. Archive ID, multiple backends	284
26.3.2. Registered agents	285
26.3.3. Timeout	285
26.4. Requests	285
26.4.1. Commands	286
26.4.2. Automatic restore	286
26.4.3. Request monitoring	286
26.5. File states	286
26.6. Tuning	287
26.6.1. hsm_controlpolicy	287
26.6.2. max_requests	287
26.6.3. policy	287
26.6.4. grace_delay	288
26.7. change logs	288
26.8. Policy engine	288
26.8.1. Robinhood	289
27. Persistent Client Cache (PCC)	L 2.13 290
27.1. Introduction	290
27.2. Design	290
27.2.1. Lustre Read-Write PCC Caching	290
27.2.2. Rule-based Persistent Client Cache	291
27.3. PCC Command Line Tools	291
27.3.1. Add a PCC backend on a client	291
27.3.2. Delete a PCC backend from a client	293
27.3.3. Remove all PCC backends on a client	293
27.3.4. List all PCC backends on a client	293
27.3.5. Attach given files into PCC	294
27.3.6. Attach given files into PCC by FID(s)	294
27.3.7. Detach given files from PCC	294
27.3.8. Detach given files from PCC by FID(s)	295
27.3.9. Display the PCC state for given files	295
27.4. PCC Configuration Example	296
28. Mapping UIDs and GIDs with Nodemap	L 2.9 297
28.1. Setting a Mapping	297
28.1.1. Defining Terms	297
28.1.2. Deciding on NID Ranges	297
28.1.3. Defining a Servers Specific Group	298
28.1.4. Describing and Deploying a Sample Mapping	298
28.1.5. Mapping Project IDs	L 2.15 300
28.2. Removing Nodemaps	300

28.3. Altering Properties	300
28.3.1. Managing the Properties	301
28.3.2. Mixing Properties	302
28.4. Enabling the Feature	303
28.5. default Nodemap	303
28.6. Verifying Settings	304
28.7. Ensuring Consistency	304
29. Configuring Shared-Secret Key (SSK) Security	L 2.9 306
29.1. SSK Security Overview	306
29.1.1. Key features	306
29.2. SSK Security Flavors	306
29.2.1. Secure RPC Rules	307
29.3. SSK Key Files	309
29.3.1. Key File Management	310
29.4. Lustre GSS Keyring	313
29.4.1. Setup	313
29.4.2. Server Setup	313
29.4.3. Debugging GSS Keyring	315
29.4.4. Revoking Keys	316
29.5. Role of Nodemap in SSK	316
29.6. SSK Examples	317
29.6.1. Securing Client to Server Communications	317
29.6.2. Securing MGS Communications	318
29.6.3. Securing Server to Server Communications	319
29.7. Viewing Secure PtlRPC Contexts	320
30. Managing Security in a Lustre File System	321
30.1. Using ACLs	321
30.1.1. How ACLs Work	321
30.1.2. Using ACLs with the Lustre Software	321
30.1.3. Examples	322
30.2. Using Root Squash	322
30.3. Isolating Clients to a Sub-directory Tree	323
30.3.1. Identifying Clients	323
30.3.2. Configuring Isolation	323
30.3.3. Making Isolation Permanent	324
30.4. Checking SELinux Policy Enforced by Lustre Clients	L 2.13 324
30.4.1. Determining SELinux Policy Info	324
30.4.2. Enforcing SELinux Policy Check	325
30.4.3. Making SELinux Policy Check Permanent	325
30.4.4. Sending SELinux Status Info from Clients	325
30.5. Encrypting files and directories	L 2.14 326
30.5.1. Client-side encryption access semantics	326
30.5.2. Client-side encryption key hierarchy	328
30.5.3. Client-side encryption modes and usage	328
30.5.4. Client-side encryption threat model	329
30.5.5. Manage encryption on directories	330
30.6. Configuring Kerberos (KRB) Security	332
30.6.1. What Is Kerberos?	333
30.6.2. Security Flavor	333
30.6.3. Kerberos Setup	334
30.6.4. Networking	335
30.6.5. Required packages	336
30.6.6. Build Lustre	336
30.6.7. Running	336

30.6.8. Secure MGS connection	338
31. Lustre ZFS Snapshots	L 2.10 339
31.1. Introduction	339
31.1.1. Requirements	339
31.2. Configuration	339
31.3. Snapshot Operations	341
31.3.1. Creating a Snapshot	341
31.3.2. Delete a Snapshot	341
31.3.3. Mounting a Snapshot	341
31.3.4. Unmounting a Snapshot	342
31.3.5. List Snapshots	343
31.3.6. Modify Snapshot Attributes	343
31.4. Global Write Barriers	343
31.4.1. Impose Barrier	344
31.4.2. Remove Barrier	344
31.4.3. Query Barrier	344
31.4.4. Rescan Barrier	345
31.5. Snapshot Logs	345
31.6. Lustre Configuration Logs	346
IV. Tuning a Lustre File System for Performance	347
32. Testing Lustre Network Performance (LNet Self-Test)	350
32.1. LNet Self-Test Overview	350
32.1.1. Prerequisites	351
32.2. Using LNet Self-Test	351
32.2.1. Creating a Session	351
32.2.2. Setting Up Groups	352
32.2.3. Defining and Running the Tests	352
32.2.4. Sample Script	353
32.3. LNet Self-Test Command Reference	354
32.3.1. Session Commands	354
32.3.2. Group Commands	355
32.3.3. Batch and Test Commands	357
32.3.4. Other Commands	360
33. Benchmarking Lustre File System Performance (Lustre I/O Kit)	363
33.1. Using Lustre I/O Kit Tools	363
33.1.1. Contents of the Lustre I/O Kit	363
33.1.2. Preparing to Use the Lustre I/O Kit	363
33.2. Testing I/O Performance of Raw Hardware (sgpdd-survey)	364
33.2.1. Tuning Linux Storage Devices	365
33.2.2. Running sgpdd-survey	365
33.3. Testing OST Performance (obdfilter-survey)	366
33.3.1. Testing Local Disk Performance	367
33.3.2. Testing Network Performance	369
33.3.3. Testing Remote Disk Performance	370
33.3.4. Output Files	371
33.4. Testing OST I/O Performance (ost-survey)	372
33.5. Testing MDS Performance (mds-survey)	373
33.5.1. Output Files	374
33.5.2. Script Output	374
33.6. Collecting Application Profiling Information (stats-collect)	375
33.6.1. Using stats-collect	375
34. Tuning a Lustre File System	377
34.1. Optimizing the Number of Service Threads	377
34.1.1. Specifying the OSS Service Thread Count	378

34.1.2. Specifying the MDS Service Thread Count	378
34.2. Binding MDS Service Thread to CPU Partitions	379
34.3. Tuning LNet Parameters	379
34.3.1. Transmit and Receive Buffer Size	379
34.3.2. Hardware Interrupts (<code>enable_irq_affinity</code>)	379
34.3.3. Binding Network Interface Against CPU Partitions	380
34.3.4. Network Interface Credits	380
34.3.5. Router Buffers	380
34.3.6. Portal Round-Robin	381
34.3.7. LNet Peer Health	382
34.4. libcfs Tuning	384
34.4.1. CPU Partition String Patterns	384
34.5. LND Tuning	385
34.5.1. ko2iblnd Tuning	385
34.6. Network Request Scheduler (NRS) Tuning	387
34.6.1. First In, First Out (FIFO) policy	390
34.6.2. Client Round-Robin over NIDs (CRR-N) policy	390
34.6.3. Object-based Round-Robin (ORR) policy	391
34.6.4. Target-based Round-Robin (TRR) policy	394
34.6.5. Token Bucket Filter (TBF) policy	L 2.6 394
34.6.6. Delay policy	L 2.10 401
34.7. Lockless I/O Tunables	403
34.8. Server-Side Advice and Hinting	L 2.9 404
34.8.1. Overview	404
34.8.2. Examples	405
34.9. Large Bulk IO (16MB RPC)	L 2.9 406
34.9.1. Overview	406
34.9.2. Usage	406
34.10. Improving Lustre I/O Performance for Small Files	407
34.11. Understanding Why Write Performance is Better Than Read Performance	407
V. Troubleshooting a Lustre File System	408
35. Lustre File System Troubleshooting	410
35.1. Lustre Error Messages	410
35.1.1. Error Numbers	410
35.1.2. Viewing Error Messages	411
35.2. Reporting a Lustre File System Bug	411
35.2.1. Searching Jira* for Duplicate Tickets	412
35.3. Common Lustre File System Problems	412
35.3.1. OST Object is Missing or Damaged	413
35.3.2. OSTs Become Read-Only	413
35.3.3. Identifying a Missing OST	414
35.3.4. Fixing a Bad LAST_ID on an OST	415
35.3.5. Handling/Debugging "Bind: Address already in use" Error ...	415
35.3.6. Handling/Debugging Error "- 28"	416
35.3.7. Triggering Watchdog for PID NNN	418
35.3.8. Handling Timeouts on Initial Lustre File System Setup	418
35.3.9. Handling/Debugging "LustreError: xxx went back in time"	419
35.3.10. Lustre Error: "Slow Start_Page_Write"	419
35.3.11. Drawbacks in Doing Multi-client O_APPEND Writes	419
35.3.12. Slowdown Occurs During Lustre File System Startup	420
35.3.13. Log Message 'Out of Memory' on OST	420
35.3.14. Setting SCSI I/O Sizes	420
36. Troubleshooting Recovery	421
36.1. Recovering from Errors or Corruption on a Backing Idiskfs File System	421

36.2. Recovering from Corruption in the Lustre File System	422
36.2.1. Working with Orphaned Objects	422
36.3. Recovering from an Unavailable OST	422
36.4. Checking the file system with LFSCK	423
36.4.1. LFSCK switch interface	424
36.4.2. Check the LFSCK global status	L 2.9 426
36.4.3. LFSCK status interface	427
36.4.4. LFSCK adjustment interface	433
37. Debugging a Lustre File System	435
37.1. Diagnostic and Debugging Tools	435
37.1.1. Lustre Debugging Tools	435
37.1.2. External Debugging Tools	436
37.2. Lustre Debugging Procedures	437
37.2.1. Understanding the Lustre Debug Messaging Format	437
37.2.2. Using the lctl Tool to View Debug Messages	439
37.2.3. Dumping the Buffer to a File (debug_daemon)	440
37.2.4. Controlling Information Written to the Kernel Debug Log	441
37.2.5. Troubleshooting with strace	442
37.2.6. Looking at Disk Content	442
37.2.7. Finding the Lustre UUID of an OST	443
37.2.8. Printing Debug Messages to the Console	444
37.2.9. Tracing Lock Traffic	444
37.2.10. Controlling Console Message Rate Limiting	444
37.3. Lustre Debugging for Developers	444
37.3.1. Adding Debugging to the Lustre Source Code	444
37.3.2. Accessing the pctlrpc Request History	447
37.3.3. Finding Memory Leaks Using leak_finder.pl	448
VI. Reference	449
38. Lustre File System Recovery	455
38.1. Recovery Overview	455
38.1.1. Client Failure	455
38.1.2. Client Eviction	456
38.1.3. MDS Failure (Failover)	456
38.1.4. OST Failure (Failover)	457
38.1.5. Network Partition	457
38.1.6. Failed Recovery	458
38.2. Metadata Replay	458
38.2.1. XID Numbers	458
38.2.2. Transaction Numbers	458
38.2.3. Replay and Resend	459
38.2.4. Client Replay List	459
38.2.5. Server Recovery	459
38.2.6. Request Replay	460
38.2.7. Gaps in the Replay Sequence	460
38.2.8. Lock Recovery	460
38.2.9. Request Resend	461
38.3. Reply Reconstruction	461
38.3.1. Required State	461
38.3.2. Reconstruction of Open Replies	461
38.3.3. Multiple Reply Data per Client	L 2.8 462
38.4. Version-based Recovery	462
38.4.1. VBR Messages	463
38.4.2. Tips for Using VBR	463
38.5. Commit on Share	463

38.5.1. Working with Commit on Share	463
38.5.2. Tuning Commit On Share	464
38.6. Imperative Recovery	464
38.6.1. MGS role	464
38.6.2. Tuning Imperative Recovery	465
38.6.3. Configuration Suggestions for Imperative Recovery	467
38.7. Suppressing Pings	468
38.7.1. "suppress_pings" Kernel Module Parameter	468
38.7.2. Client Death Notification	468
39. Lustre Parameters	469
39.1. Introduction to Lustre Parameters	469
39.1.1. Identifying Lustre File Systems and Servers	470
39.2. Tuning Multi-Block Allocation (mballoc)	472
39.3. Monitoring Lustre File System I/O	473
39.3.1. Monitoring the Client RPC Stream	474
39.3.2. Monitoring Client Activity	475
39.3.3. Monitoring Client Read-Write Offset Statistics	477
39.3.4. Monitoring Client Read-Write Extent Statistics	478
39.3.5. Monitoring the OST Block I/O Stream	480
39.4. Tuning Lustre File System I/O	482
39.4.1. Tuning the Client I/O RPC Stream	482
39.4.2. Tuning File Readahead and Directory Statahead	484
39.4.3. Tuning Server Read Cache	485
39.4.4. Enabling OSS Asynchronous Journal Commit	488
39.4.5. Tuning the Client Metadata RPC Stream	L 2.8 489
39.5. Configuring Timeouts in a Lustre File System	490
39.5.1. Configuring Adaptive Timeouts	491
39.5.2. Setting Static Timeouts	493
39.6. Monitoring LNet	495
39.7. Allocating Free Space on OSTs	496
39.8. Configuring Locking	497
39.9. Setting MDS and OSS Thread Counts	498
39.10. Enabling and Interpreting Debugging Logs	499
39.10.1. Interpreting OST Statistics	501
39.10.2. Interpreting MDT Statistics	503
40. User Utilities	504
40.1. <code>lfs</code>	504
40.1.1. Synopsis	504
40.1.2. Description	505
40.1.3. Options	505
40.1.4. Examples	510
40.1.5. See Also	512
40.2. <code>lfs_migrate</code>	512
40.2.1. Synopsis	512
40.2.2. Description	512
40.2.3. Options	513
40.2.4. Examples	514
40.2.5. See Also	514
40.3. <code>filefrag</code>	514
40.3.1. Synopsis	514
40.3.2. Description	514
40.3.3. Options	515
40.3.4. Examples	515
40.4. <code>mount</code>	516

40.5. Handling Timeouts	516
41. Programming Interfaces	518
41.1. User/Group Upcall	518
41.1.1. Synopsis	518
41.1.2. Description	518
41.1.3. Data Structures	519
42. Setting Lustre Properties in a C Program (llapi)	520
42.1. llapi_file_create	520
42.1.1. Synopsis	520
42.1.2. Description	520
42.1.3. Examples	521
42.2. llapi_file_get_stripe	521
42.2.1. Synopsis	521
42.2.2. Description	522
42.2.3. Return Values	523
42.2.4. Errors	523
42.2.5. Examples	523
42.3. llapi_file_open	524
42.3.1. Synopsis	524
42.3.2. Description	524
42.3.3. Return Values	525
42.3.4. Errors	525
42.3.5. Example	525
42.4. llapi_quotactl	526
42.4.1. Synopsis	526
42.4.2. Description	526
42.4.3. Return Values	527
42.4.4. Errors	527
42.5. llapi_path2fid	528
42.5.1. Synopsis	528
42.5.2. Description	528
42.5.3. Return Values	528
42.6. llapi_ladvise	L 2.9 528
42.6.1. Synopsis	528
42.6.2. Description	529
42.6.3. Return Values	530
42.6.4. Errors	530
42.7. Example Using the llapi Library	530
42.7.1. See Also	534
43. Configuration Files and Module Parameters	535
43.1. Introduction	535
43.2. Module Options	535
43.2.1. LNet Options	536
43.2.2. SOCKLND Kernel TCP/IP LND	539
44. System Configuration Utilities	542
44.1. l_getidentity	542
44.1.1. Synopsis	542
44.1.2. Description	542
44.1.3. Options	543
44.1.4. Files	543
44.2. lctl	543
44.2.1. Synopsis	543
44.2.2. Description	543
44.2.3. Setting Parameters with lctl	543

44.2.4. Options	548
44.2.5. Examples	548
44.2.6. See Also	548
44.3. ll_decode_filter_fid	548
44.3.1. Synopsis	548
44.3.2. Description	548
44.3.3. Examples	549
44.4. llobdstat	549
44.4.1. Synopsis	549
44.4.2. Description	549
44.4.3. Example	549
44.4.4. Files	550
44.5. llog_reader	550
44.5.1. Synopsis	550
44.5.2. Description	550
44.5.3. See Also	550
44.6. llstat	550
44.6.1. Synopsis	550
44.6.2. Description	550
44.6.3. Options	551
44.6.4. Example	551
44.6.5. Files	551
44.7. llverdev	551
44.7.1. Synopsis	551
44.7.2. Description	551
44.7.3. Options	552
44.7.4. Examples	552
44.8. lshowmount	553
44.8.1. Synopsis	553
44.8.2. Description	553
44.8.3. Options	553
44.8.4. Files	553
44.9. lst	553
44.9.1. Synopsis	553
44.9.2. Description	554
44.9.3. Modules	554
44.9.4. Utilities	554
44.9.5. Example Script	554
44.10. lustre_rmmod.sh	555
44.11. lustre_rsync	555
44.11.1. Synopsis	555
44.11.2. Description	555
44.11.3. Options	556
44.11.4. Examples	557
44.11.5. See Also	557
44.12. mkfs.lustre	558
44.12.1. Synopsis	558
44.12.2. Description	558
44.12.3. Examples	560
44.12.4. See Also	560
44.13. mount.lustre	560
44.13.1. Synopsis	560
44.13.2. Description	560
44.13.3. Options	561

44.13.4. Examples	564
44.13.5. See Also	565
44.14. routerstat	565
44.14.1. Synopsis	565
44.14.2. Description	565
44.14.3. Output	565
44.14.4. Example	566
44.14.5. Files	566
44.15. tunefs.lustre	566
44.15.1. Synopsis	566
44.15.2. Description	566
44.15.3. Options	567
44.15.4. Examples	569
44.15.5. See Also	569
44.16. Additional System Configuration Utilities	569
44.16.1. More Statistics for Application Profiling	569
44.16.2. Testing / Debugging Utilities	569
44.16.3. Fileset Feature	L 2.9 570
45. LNet Configuration C-API	573
45.1. General API Information	573
45.1.1. API Return Code	573
45.1.2. API Common Input Parameters	573
45.1.3. API Common Output Parameters	573
45.2. The LNet Configuration C-API	575
45.2.1. Configuring LNet	575
45.2.2. Enabling and Disabling Routing	575
45.2.3. Adding Routes	576
45.2.4. Deleting Routes	577
45.2.5. Showing Routes	577
45.2.6. Adding a Network Interface	578
45.2.7. Deleting a Network Interface	579
45.2.8. Showing Network Interfaces	580
45.2.9. Adjusting Router Buffer Pools	581
45.2.10. Showing Routing information	582
45.2.11. Showing LNet Traffic Statistics	583
45.2.12. Adding/Deleting/Showing Parameters through a YAML Block	584
45.2.13. Adding a route code example	585
Glossary	588
Index	595

List of Figures

1.1. Lustre file system components in a basic cluster	6
1.2. Lustre cluster at scale	9
1.3. Layout EA on MDT pointing to file data on OSTs	10
1.4. Lustre client requesting file data	10
1.5. File striping on a Lustre file system	12
3.1. Lustre failover configuration for a active/passive MDT	18
3.2. Lustre failover configuration for a active/active MDTs	19
3.3. Lustre failover configuration for an OSTs	19
16.1. Routing Configuration with Multi-Rail	150
19.1. PFL object mapping diagram	189
19.2. Example: create a composite file	190
19.3. Example: add a component to an existing composite file	193
19.4. Example: delete a component from an existing file	195
19.5. Example: migrate normal to composite	198
19.6. Example: migrate composite to composite	199
19.7. Example: migrate composite to normal	201
19.8. Example: create a SEL file	207
19.9. Example: an extension of a SEL file	210
19.10. Example: a spillover in a SEL file	212
19.11. Example: repeat a SEL component	213
19.12. Example: forced extension in a SEL file	214
19.13. LOV/LMV foreign format	217
19.14. Example: create a foreign file	218
20.1. Resulting file layout	225
22.1. FLR Delayed Write	235
26.1. Overview of the Lustre file system HSM	283
27.1. Overview of PCC-RW Architecture	290
34.1. One of Two Connections to o2ib0 Down	383
34.2. Both Connections to o2ib0 Down	383
34.3. Connection to o2ib1 Down	383
34.4. Connection to o2ib1 Never Came Up	383
34.5. The internal structure of TBF policy	394
44.1. Lustre filesset	571

List of Tables

1.1. Lustre File System Scalability and Performance	4
1.2. Storage and hardware requirements for Lustre file system components	8
5.1. Default Inode Ratios Used for Newly Formatted OSTs	31
5.2. File and file system limits	32
8.1. Packages Installed on Lustre Servers	50
8.2. Packages Installed on Lustre Clients	51
8.3. Network Types Supported by Lustre LNDs	51
10.1. Default stripe pattern	81
16.1. Configuring Module Parameters	152
29.1. SSK Security Flavor Protections	307
29.2. lgss_sk Parameters	310
29.3. lsvcgssd Parameters	313
29.4. Key Descriptions	314
31.1. Write Barrier Status	345

List of Examples

34.1. lustre.conf	379
-------------------------	-----

Preface

The *Lustre^{*} Software Release 2.x Operations Manual* provides detailed information and procedures to install, configure and tune a Lustre file system. The manual covers topics such as failover, quotas, striping, and bonding. This manual also contains troubleshooting information and tips to improve the operation and performance of a Lustre file system.

1. About this Document

This document is maintained by Whamcloud in Docbook format. The canonical version is available at <https://wiki.whamcloud.com/display/PUB/Documentation> [<https://wiki.whamcloud.com/display/PUB/Documentation>].

1.1. UNIX^{*} Commands

This document does not contain information about basic UNIX^{*} operating system commands and procedures such as shutting down the system, booting the system, and configuring devices. Refer to the following for this information:

- Software documentation that you received with your system
- Red Hat^{*} Enterprise Linux^{*} documentation, which is at: <https://docs.redhat.com/docs/en-US/index.html> [<https://docs.redhat.com/docs/en-US/index.html>]

Note

The Lustre client module is available for many different Linux^{*} versions and distributions. The Red Hat Enterprise Linux distribution is the best supported and tested platform for Lustre servers.

1.2. Shell Prompts

The shell prompt used in the example text indicates whether a command can or should be executed by a regular user, or whether it requires superuser permission to run. Also, the machine type is often included in the prompt to indicate whether the command should be run on a client node, on an MDS node, an OSS node, or the MGS node.

Some examples are listed below, but other prompt combinations are also used as needed for the example.

Shell	Prompt
Regular user	machine\$
Superuser (root)	machine#
Regular user on the client	client\$
Superuser on the MDS	mgs#
Superuser on the OSS	oss#
Superuser on the MGS	mgs#

1.3. Related Documentation

Application	Title	Format	Location
Latest information	<i>Lustre Software Release 2.x Change Logs</i>	Wiki page	Online at https://wiki.whamcloud.com/display/PUB/Documentation
Service	<i>Lustre Software Release 2.x Operations Manual</i>	PDF HTML	Online at https://wiki.whamcloud.com/display/PUB/Documentation

1.4. Documentation and Support

These web sites provide additional resources:

- Documentation <https://wiki.whamcloud.com/display/PUB/Documentation> [<https://wiki.whamcloud.com/display/PUB/Documentation>] <https://www.lustre.org>
- Support <https://jira.whamcloud.com/>

2. Revisions

The Lustre* File System Release 2.x Operations Manual is a community maintained work. Versions of the manual are continually built as suggestions for changes and improvements arrive. Suggestions for improvements can be submitted through the ticketing system maintained at <https://jira.whamcloud.com/browse/LUDOC> [<https://jira.whamcloud.com/browse/LUDOC>]. Instructions for providing a patch to the existing manual are available at: http://wiki.lustre.org/Lustre_Manual_Changes [http://wiki.lustre.org/Lustre_Manual_Changes].

Introduced in Lustre 2.5

This manual covers a range of Lustre 2.x software releases, currently starting with the 2.5 release. Features specific to individual releases are identified within the table of contents using a shorthand notation (e.g. this paragraph is tagged as a Lustre 2.5 specific feature so that it will be updated when the 2.5-specific tagging is removed), and within the text using a distinct box.

Which version am I running?

The current version of Lustre that is in use on the node can be found using the command `lctl get_param version` on any Lustre client or server, for example:

```
$ lctl get_param version
version=2.10.5
```

Only the latest revision of this document is made readily available because changes are continually arriving. The current and latest revision of this manual is available from links maintained at: <http://lustre.opensfs.org/documentation/> [<http://lustre.opensfs.org/documentation/>].

Revision History

Revision 0

Built on 20 August 2024 01:58:00Z Intel Corporation

Continuous build of Manual.

Part I. Introducing the Lustre^{*} File System

Part I provides background information to help you understand the Lustre file system architecture and how the major components fit together. You will find information in this section about:

- Understanding Lustre Architecture
- Understanding Lustre Networking (LNet)
- Understanding Failover in a Lustre File System

Table of Contents

1. Understanding Lustre Architecture	3
1.1. What a Lustre File System Is (and What It Isn't)	3
1.1.1. Lustre Features	3
1.2. Lustre Components	6
1.2.1. Management Server (MGS)	7
1.2.2. Lustre File System Components	7
1.2.3. Lustre Networking (LNet)	8
1.2.4. Lustre Cluster	8
1.3. Lustre File System Storage and I/O	9
1.3.1. Lustre File System and Striping	11
2. Understanding Lustre Networking (LNet)	14
2.1. Introducing LNet	14
2.2. Key Features of LNet	14
2.3. Lustre Networks	14
2.4. Supported Network Types	15
3. Understanding Failover in a Lustre File System	16
3.1. What is Failover?	16
3.1.1. Failover Capabilities	16
3.1.2. Types of Failover Configurations	17
3.2. Failover Functionality in a Lustre File System	17
3.2.1. MDT Failover Configuration (Active/Passive)	18
3.2.2. MDT Failover Configuration (Active/Active)	18
3.2.3. OST Failover Configuration (Active/Active)	19

Chapter 1. Understanding Lustre Architecture

This chapter describes the Lustre architecture and features of the Lustre file system. It includes the following sections:

- Section 1.1, “What a Lustre File System Is (and What It Isn't)”
- Section 1.2, “Lustre Components”
- Section 1.3, “Lustre File System Storage and I/O”

1.1. What a Lustre File System Is (and What It Isn't)

The Lustre architecture is a storage architecture for clusters. The central component of the Lustre architecture is the Lustre file system, which is supported on the Linux operating system and provides a POSIX^{*} standard-compliant UNIX file system interface.

The Lustre storage architecture is used for many different kinds of clusters. It is best known for powering many of the largest high-performance computing (HPC) clusters worldwide, with tens of thousands of client systems, petabytes (PiB) of storage and hundreds of gigabytes per second (GB/sec) of I/O throughput. Many HPC sites use a Lustre file system as a site-wide global file system, serving dozens of clusters.

The ability of a Lustre file system to scale capacity and performance for any need reduces the need to deploy many separate file systems, such as one for each compute cluster. Storage management is simplified by avoiding the need to copy data between compute clusters. In addition to aggregating storage capacity of many servers, the I/O throughput is also aggregated and scales with additional servers. Moreover, throughput and/or capacity can be easily increased by adding servers dynamically.

While a Lustre file system can function in many work environments, it is not necessarily the best choice for all applications. It is best suited for uses that exceed the capacity that a single server can provide, though in some use cases, a Lustre file system can perform better with a single server than other file systems due to its strong locking and data coherency.

A Lustre file system is currently not particularly well suited for "peer-to-peer" usage models where clients and servers are running on the same node, each sharing a small amount of storage, due to the lack of data replication at the Lustre software level. In such uses, if one client/server fails, then the data stored on that node will not be accessible until the node is restarted.

1.1.1. Lustre Features

Lustre file systems run on a variety of vendor's kernels. For more details, see the Lustre Test Matrix Section 8.1, “Preparing to Install the Lustre Software”.

A Lustre installation can be scaled up or down with respect to the number of client nodes, disk storage and bandwidth. Scalability and performance are dependent on available disk and network bandwidth and the processing power of the servers in the system. A Lustre file system can be deployed in a wide variety of configurations that can be scaled well beyond the size and performance observed in production systems to date.

Table 1.1, “Lustre File System Scalability and Performance” shows some of the scalability and performance characteristics of a Lustre file system. For a full list of Lustre file and filesystem limits see Table 5.2, “File and file system limits”.

Table 1.1. Lustre File System Scalability and Performance

Feature	Current Practical Range	Known Production Usage
Client Scalability	100-100000	50000+ clients, many in the 10000 to 20000 range
Client Performance	<i>Single client:</i> I/O 90% of network bandwidth <i>Aggregate:</i> 50 TB/sec I/O, 50M IOPS	<i>Single client:</i> 15 GB/sec I/O (HDR IB), 50000 IOPS <i>Aggregate:</i> 10 TB/sec I/O, 10M IOPS
OSS Scalability	<i>Single OSS:</i> 1-32 OSTs per OSS <i>Single OST:</i> 500M objects, 1024TiB per OST <i>OSS count:</i> 1000 OSSs, 4000 OSTs	<i>Single OSS:</i> 4 OSTs per OSS <i>Single OST:</i> 1024TiB OSTs <i>OSS count:</i> 450 OSSs with 900 750TiB HDD OSTs + 450 25TiB NVMe OSTs 1024 OSSs with 1024 72TiB OSTs
OSS Performance	<i>Single OSS:</i> 15 GB/sec, 1.5M IOPS <i>Aggregate:</i> 50 TB/sec, 50M IOPS	<i>Single OSS:</i> 10 GB/sec, 1.5M IOPS <i>Aggregate:</i> 20 TB/sec, 20M IOPS
MDS Scalability	<i>Single MDS:</i> 1-4 MDTs per MDS <i>Single MDT:</i> 4 billion files, 16TiB per MDT (ldiskfs) 64 billion files, 64TiB per MDT (ZFS) <i>MDS count:</i> 256 MDSs, up to 256 MDTs	<i>Single MDS:</i> 4 billion files <i>MDS count:</i> 40 MDS with 40 4TiB MDTs in production 256 MDS with 256 64GiB MDTs in testing
MDS Performance	1M/s create operations 2M/s stat operations	100k/s create operations, 200k/s metadata stat operations

Feature	Current Practical Range	Known Production Usage
File system Scalability	<i>Single File:</i> 32 PiB max file size (ldiskfs) 2 ⁶³ bytes (ZFS) <i>Aggregate:</i> 512 PiB space, 1 trillion files	<i>Single File:</i> multi-TiB max file size <i>Aggregate:</i> 700 PiB space, 25 billion files

Other Lustre software features are:

- **Performance-enhanced ext4 file system:**The Lustre file system uses an improved version of the ext4 journaling file system to store data and metadata. This version, called *ldiskfs*, has been enhanced to improve performance and provide additional functionality needed by the Lustre file system.
- It is also possible to use ZFS as the backing filesystem for Lustre for the MDT, OST, and MGS storage. This allows Lustre to leverage the scalability and data integrity features of ZFS for individual storage targets.
- **POSIX standard compliance:**The full POSIX test suite passes in an identical manner to a local ext4 file system, with limited exceptions on Lustre clients. In a cluster, most operations are atomic so that clients never see stale data or metadata. The Lustre software supports mmap() file I/O.
- **High-performance heterogeneous networking:**The Lustre software supports a variety of high performance, low latency networks and permits Remote Direct Memory Access (RDMA) for InfiniBand* (utilizing OpenFabrics Enterprise Distribution (OFED*), Intel OmniPath®, and other advanced networks for fast and efficient network transport. Multiple RDMA networks can be bridged using Lustre routing for maximum performance. The Lustre software also includes integrated network diagnostics.
- **High-availability:**The Lustre file system supports active/active failover using shared storage partitions for OSS targets (OSTs), and for MDS targets (MDTs). The Lustre file system can work with a variety of high availability (HA) managers to allow automated failover and has no single point of failure (NSPF). This allows application transparent recovery. Multiple mount protection (MMP) provides integrated protection from errors in highly-available systems that would otherwise cause file system corruption.
- **Security:**By default TCP connections are only allowed from privileged ports. UNIX group membership is verified on the MDS.
- **Access control list (ACL), extended attributes:**the Lustre security model follows that of a UNIX file system, enhanced with POSIX ACLs. Noteworthy additional features include root squash.
- **Interoperability:**The Lustre file system runs on a variety of CPU architectures and mixed-endian clusters and is interoperable between successive major Lustre software releases.
- **Object-based architecture:**Clients are isolated from the on-disk file structure enabling upgrading of the storage architecture without affecting the client.
- **Byte-granular file and fine-grained metadata locking:**Many clients can read and modify the same file or directory concurrently. The Lustre distributed lock manager (LDLM) ensures that files are coherent between all clients and servers in the file system. The MDT LDLM manages locks on inode permissions and pathnames. Each OST has its own LDLM for locks on file stripes stored thereon, which scales the locking performance as the file system grows.
- **Quotas:**User and group quotas are available for a Lustre file system.

- **Capacity growth:**The size of a Lustre file system and aggregate cluster bandwidth can be increased without interruption by adding new OSTs and MDTs to the cluster.
- **Controlled file layout:**The layout of files across OSTs can be configured on a per file, per directory, or per file system basis. This allows file I/O to be tuned to specific application requirements within a single file system. The Lustre file system uses RAID-0 striping and balances space usage across OSTs.
- **Network data integrity protection:**A checksum of all data sent from the client to the OSS protects against corruption during data transfer.
- **MPI I/O:**The Lustre architecture has a dedicated MPI ADIO layer that optimizes parallel I/O to match the underlying file system architecture.
- **NFS and CIFS export:**Lustre files can be re-exported using NFS (via Linux knfsd or Ganesha) or CIFS (via Samba), enabling them to be shared with non-Linux clients such as Microsoft *Windows*, *Apple *Mac OS X*, and others.
- **Disaster recovery tool:**The Lustre file system provides an online distributed file system check (LFSCK) that can restore consistency between storage components in case of a major file system error. A Lustre file system can operate even in the presence of file system inconsistencies, and LFSCK can run while the filesystem is in use, so LFSCK is not required to complete before returning the file system to production.
- **Performance monitoring:**The Lustre file system offers a variety of mechanisms to examine performance and tuning.
- **Open source:**The Lustre software is licensed under the GPL 2.0 license for use with the Linux operating system.

1.2. Lustre Components

An installation of the Lustre software includes a management server (MGS) and one or more Lustre file systems interconnected with Lustre networking (LNet).

A basic configuration of Lustre file system components is shown in Figure 1.1, “Lustre file system components in a basic cluster”.

Figure 1.1. Lustre file system components in a basic cluster

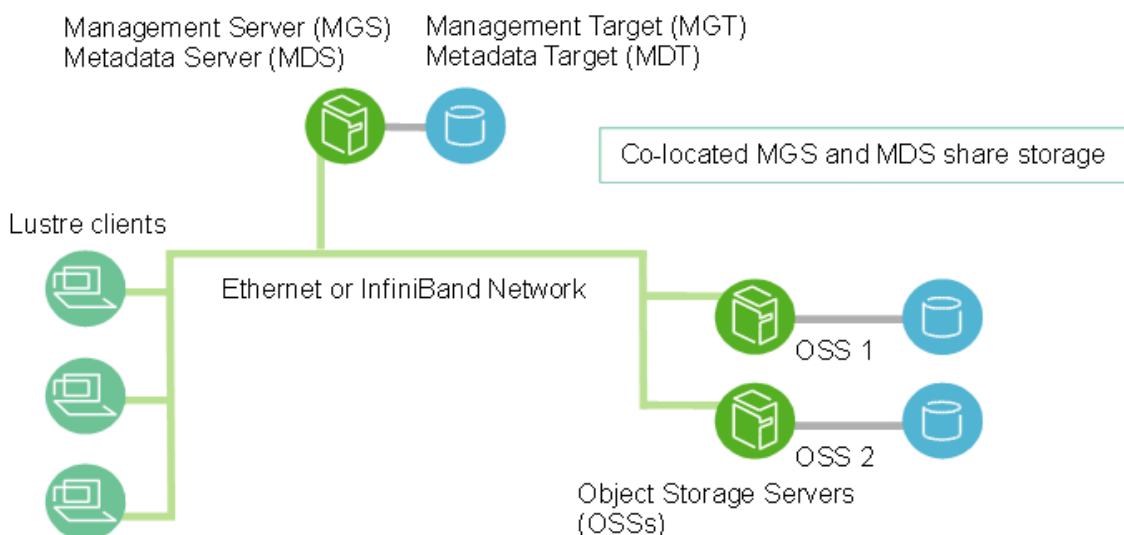

1.2.1. Management Server (MGS)

The MGS stores configuration information for all the Lustre file systems in a cluster and provides this information to other Lustre components. Each Lustre target contacts the MGS to provide information, and Lustre clients contact the MGS to retrieve information.

It is preferable that the MGS have its own storage space so that it can be managed independently. However, the MGS can be co-located and share storage space with an MDS as shown in Figure 1.1, “Lustre file system components in a basic cluster”.

1.2.2. Lustre File System Components

Each Lustre file system consists of the following components:

- **Metadata Servers (MDS)**- The MDS makes metadata stored in one or more MDTs available to Lustre clients. Each MDS manages the names and directories in the Lustre file system(s) and provides network request handling for one or more local MDTs.
- **Metadata Targets (MDT)** - Each filesystem has at least one MDT, which holds the root directory. The MDT stores metadata (such as filenames, directories, permissions and file layout) on storage attached to an MDS. Each file system has one MDT. An MDT on a shared storage target can be available to multiple MDSs, although only one can access it at a time. If an active MDS fails, a second MDS node can serve the MDT and make it available to clients. This is referred to as MDS failover.

Multiple MDTs are supported with the Distributed Namespace Environment (Distributed Namespace Environment (DNE)). In addition to the primary MDT that holds the filesystem root, it is possible to add additional MDS nodes, each with their own MDTs, to hold sub-directory trees of the filesystem.

Introduced in Lustre 2.8

Since Lustre software release 2.8, DNE also allows the filesystem to distribute files of a single directory over multiple MDT nodes. A directory which is distributed across multiple MDTs is known as a *Striped Directory*.

- **Object Storage Servers (OSS)**: The OSS provides file I/O service and network request handling for one or more local OSTs. Typically, an OSS serves between two and eight OSTs, up to 16 TiB each. A typical configuration is an MDT on a dedicated node, two or more OSTs on each OSS node, and a client on each of a large number of compute nodes.
- **Object Storage Target (OST)**: User file data is stored in one or more objects, each object on a separate OST in a Lustre file system. The number of objects per file is configurable by the user and can be tuned to optimize performance for a given workload.
- **Lustre clients**: Lustre clients are computational, visualization or desktop nodes that are running Lustre client software, allowing them to mount the Lustre file system.

The Lustre client software provides an interface between the Linux virtual file system and the Lustre servers. The client software includes a management client (MGC), a metadata client (MDC), and multiple object storage clients (OSCs), one corresponding to each OST in the file system.

A logical object volume (LOV) aggregates the OSCs to provide transparent access across all the OSTs. Thus, a client with the Lustre file system mounted sees a single, coherent, synchronized namespace. Several clients can write to different parts of the same file simultaneously, while, at the same time, other clients can read from the file.

A logical metadata volume (LMV) aggregates the MDCs to provide transparent access across all the MDTs in a similar manner as the LOV does for file access. This allows the client to see the directory tree on multiple MDTs as a single coherent namespace, and striped directories are merged on the clients to form a single visible directory to users and applications.

Table 1.2, “ Storage and hardware requirements for Lustre file system components”provides the requirements for attached storage for each Lustre file system component and describes desirable characteristics of the hardware used.

Table 1.2. Storage and hardware requirements for Lustre file system components

	Required attached storage	Desirable hardware characteristics
MDSs	1-2% of file system capacity	Adequate CPU power, plenty of memory, fast disk storage.
OSSs	1-128 TiB per OST, 1-8 OSTs per OSS	Good bus bandwidth. Recommended that storage be balanced evenly across OSSs and matched to network bandwidth.
Clients	No local storage needed	Low latency, high bandwidth network.

For additional hardware requirements and considerations, see Chapter 5, *Determining Hardware Configuration Requirements and Formatting Options*.

1.2.3. Lustre Networking (LNet)

Lustre Networking (LNet) is a custom networking API that provides the communication infrastructure that handles metadata and file I/O data for the Lustre file system servers and clients. For more information about LNet, see Chapter 2, *Understanding Lustre Networking (LNet)*.

1.2.4. Lustre Cluster

At scale, a Lustre file system cluster can include hundreds of OSSs and thousands of clients (see Figure 1.2, “ Lustre cluster at scale”). More than one type of network can be used in a Lustre cluster. Shared storage between OSSs enables failover capability. For more details about OSS failover, see Chapter 3, *Understanding Failover in a Lustre File System*.

Figure 1.2. Lustre cluster at scale

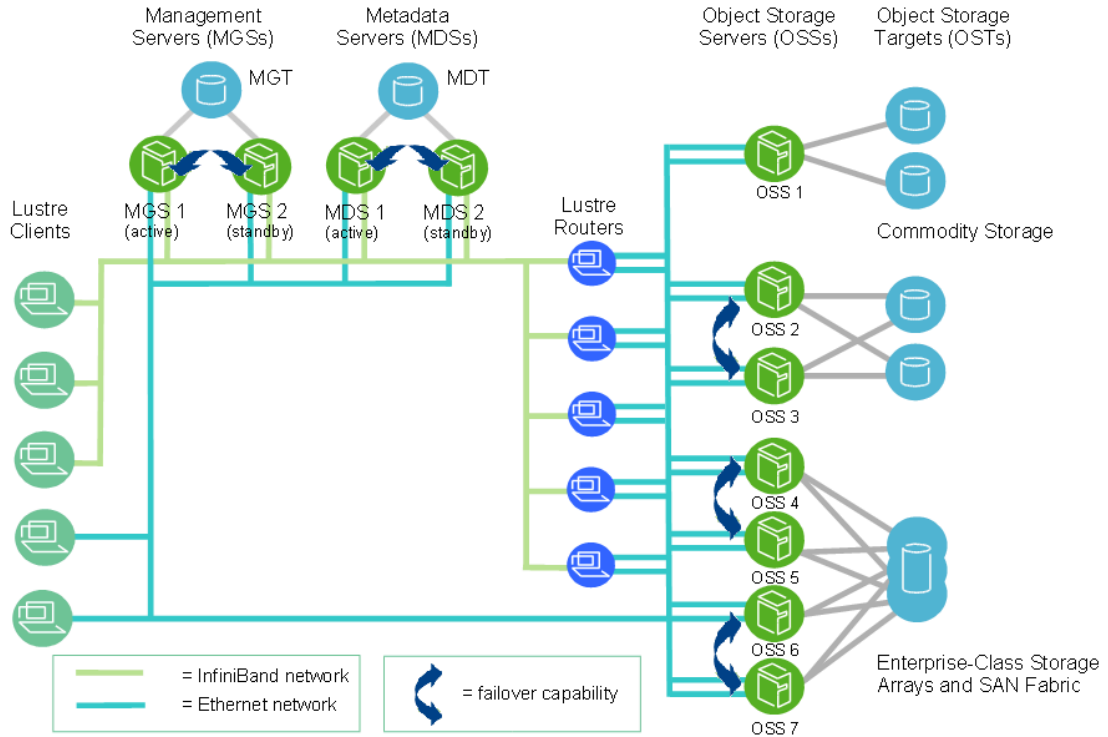

1.3. Lustre File System Storage and I/O

Lustre File Identifiers (FIDs) are used internally for identifying files or objects, similar to inode numbers in local filesystems. A FID is a 128-bit identifier, which contains a unique 64-bit sequence number (SEQ), a 32-bit object ID (OID), and a 32-bit version number. The sequence number is unique across all Lustre targets in a file system (OSTs and MDTs). This allows multiple MDTs and OSTs to uniquely identify objects without depending on identifiers in the underlying filesystem (e.g. inode numbers) that are likely to be duplicated between targets. The FID SEQ number also allows mapping a FID to a particular MDT or OST.

The LFSCCK file system consistency checking tool provides functionality that enables FID-in-dirent for existing files. It includes the following functionality:

- Verifies the FID stored with each directory entry and regenerates it from the inode if it is invalid or missing.
- Verifies the linkEA entry for each inode and regenerates it if invalid or missing. The *linkEA* stores the file name and parent FID. It is stored as an extended attribute in each inode. Thus, the *linkEA* can be used to reconstruct the full path name of a file from only the FID.

Information about where file data is located on the OST(s) is stored as an extended attribute called layout EA in an MDT object identified by the FID for the file (see Figure 1.3, “Layout EA on MDT pointing to file data on OSTs”). If the file is a regular file (not a directory or symbol link), the MDT object points to 1-to-N OST object(s) on the OST(s) that contain the file data. If the MDT file points to one object, all the file data is stored in that object. If the MDT file points to more than one object, the file data is *striped* across the objects using RAID 0, and each object is stored on a different OST. (For more information about how striping is implemented in a Lustre file system, see Section 1.3.1, “Lustre File System and Striping”).

Figure 1.3. Layout EA on MDT pointing to file data on OSTs

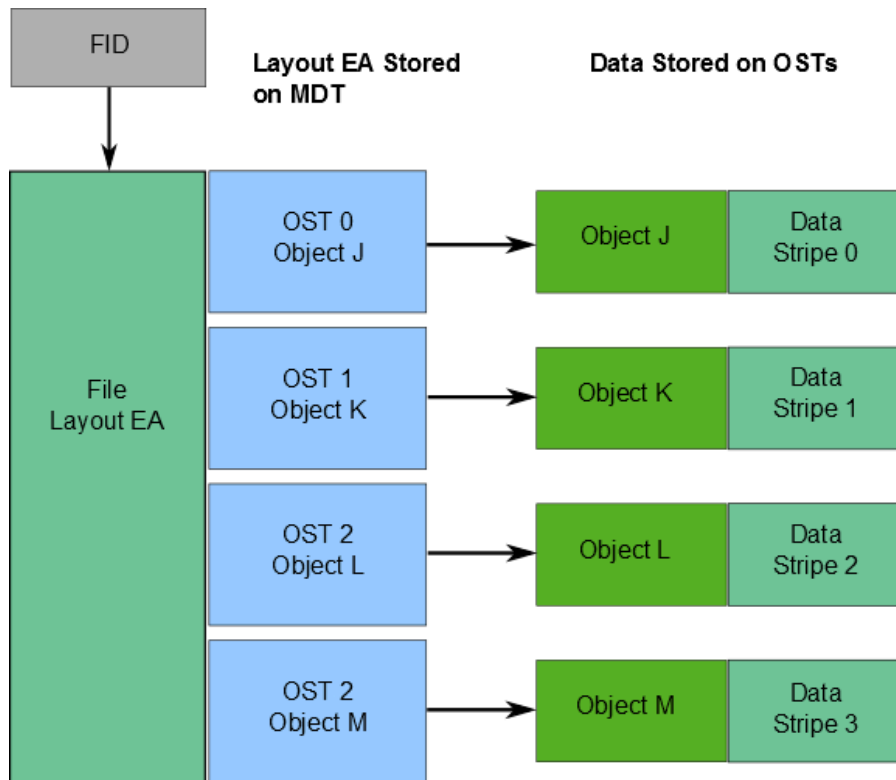

When a client wants to read from or write to a file, it first fetches the layout EA from the MDT object for the file. The client then uses this information to perform I/O on the file, directly interacting with the OSS nodes where the objects are stored. This process is illustrated in Figure 1.4, “Lustre client requesting file data” .

Figure 1.4. Lustre client requesting file data

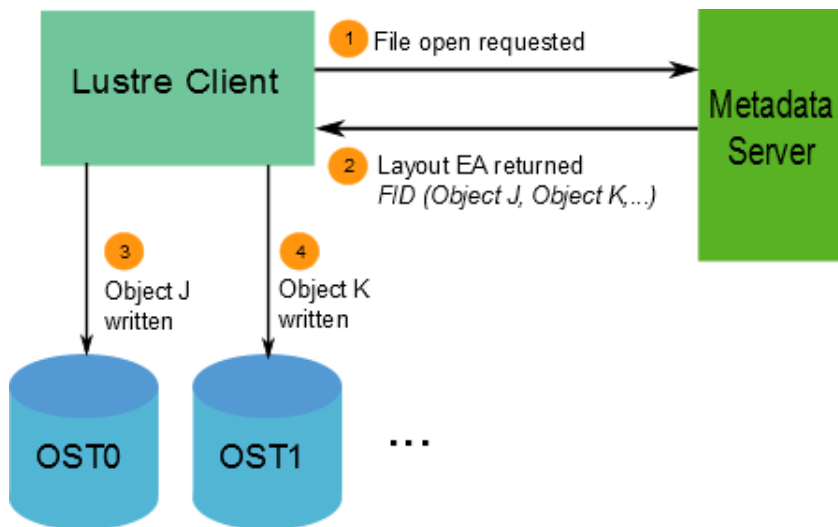

The available bandwidth of a Lustre file system is determined as follows:

- The *network bandwidth* equals the aggregated bandwidth of the OSSs to the targets.

- The *disk bandwidth* equals the sum of the disk bandwidths of the storage targets (OSTs) up to the limit of the network bandwidth.
- The *aggregate bandwidth* equals the minimum of the disk bandwidth and the network bandwidth.
- The *available file system space* equals the sum of the available space of all the OSTs.

1.3.1. Lustre File System and Striping

One of the main factors leading to the high performance of Lustre file systems is the ability to stripe data across multiple OSTs in a round-robin fashion. Users can optionally configure for each file the number of stripes, stripe size, and OSTs that are used.

Striping can be used to improve performance when the aggregate bandwidth to a single file exceeds the bandwidth of a single OST. The ability to stripe is also useful when a single OST does not have enough free space to hold an entire file. For more information about benefits and drawbacks of file striping, see Section 19.2, “Lustre File Layout (Striping) Considerations”.

Striping allows segments or 'chunks' of data in a file to be stored on different OSTs, as shown in Figure 1.5, “File striping on a Lustre file system”. In the Lustre file system, a RAID 0 pattern is used in which data is "striped" across a certain number of objects. The number of objects in a single file is called the `stripe_count`.

Each object contains a chunk of data from the file. When the chunk of data being written to a particular object exceeds the `stripe_size`, the next chunk of data in the file is stored on the next object.

Default values for `stripe_count` and `stripe_size` are set for the file system. The default value for `stripe_count` is 1 stripe for file and the default value for `stripe_size` is 1MB. The user may change these values on a per directory or per file basis. For more details, see Section 19.3, “Setting the File Layout/Striping Configuration (`lfs setstripe`)”.

Figure 1.5, “File striping on a Lustre file system”, the `stripe_size` for File C is larger than the `stripe_size` for File A, allowing more data to be stored in a single stripe for File C. The `stripe_count` for File A is 3, resulting in data striped across three objects, while the `stripe_count` for File B and File C is 1.

No space is reserved on the OST for unwritten data. File A in Figure 1.5, “File striping on a Lustre file system”.

Figure 1.5. File striping on a Lustre file system

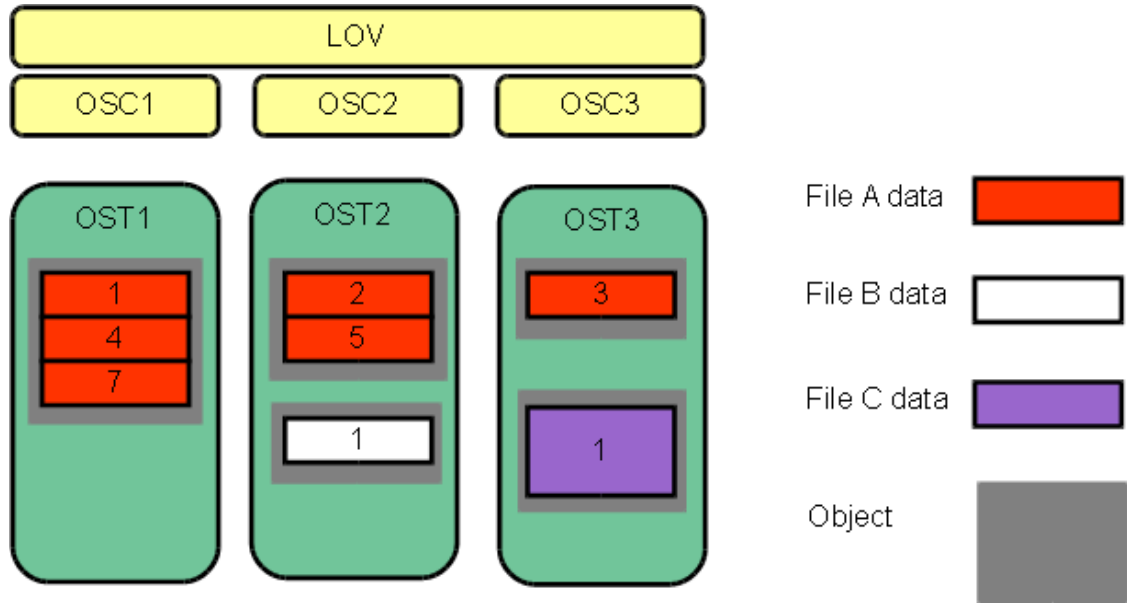

The maximum file size is not limited by the size of a single target. In a Lustre file system, files can be striped across multiple objects (up to 2000), and each object can be up to 16 TiB in size with `ldiskfs`, or up to 256PiB with ZFS. This leads to a maximum file size of 31.25 PiB for `ldiskfs` or 8EiB with ZFS. Note that a Lustre file system can support files up to 2^{63} bytes (8EiB), limited only by the space available on the OSTs.

Note

`ldiskfs` filesystems without the `ea_inode` feature limit the maximum stripe count for a single file to 160 OSTs.

Although a single file can only be striped over 2000 objects, Lustre file systems can have thousands of OSTs. The I/O bandwidth to access a single file is the aggregated I/O bandwidth to the objects in a file, which can be as much as a bandwidth of up to 2000 servers. On systems with more than 2000 OSTs, clients can do I/O using multiple files to utilize the full file system bandwidth.

For more information about striping, see Chapter 19, *Managing File Layout (Striping) and Free Space*.

Extended Attributes(xattrs)

Lustre uses `lov_user_md_v1/lov_user_md_v3` data-structures to maintain its file striping information under `xattrs`. Extended attributes are created when files and directory are created. Lustre uses `trusted` extended attributes to store its parameters which are root-only accessible. The parameters are:

- **trusted.lov:** Holds layout for a regular file, or default file layout stored on a directory (also accessible as `lustre.lov` for non-root users).
- **trusted.lma:** Holds FID and extra state flags for current file
- **trusted.lmv:** Holds layout for a striped directory (DNE 2), not present otherwise
- **trusted.link:** Holds parent directory FID + filename for each link to a file (for `lfs fid2path`)

`xattr` which are stored and present in the file could be verify using:

```
# getfattr -d -m - /mnt/testfs/file>
```

Chapter 2. Understanding Lustre Networking (LNet)

This chapter introduces Lustre networking (LNet). It includes the following sections:

- Section 2.1, “Introducing LNet”
- Section 2.2, “Key Features of LNet”
- Section 2.3, “Lustre Networks”
- Section 2.4, “Supported Network Types”

2.1. Introducing LNet

In a cluster using one or more Lustre file systems, the network communication infrastructure required by the Lustre file system is implemented using the Lustre networking (LNet) feature.

LNet supports many commonly-used network types, such as InfiniBand and IP networks, and allows simultaneous availability across multiple network types with routing between them. Remote direct memory access (RDMA) is permitted when supported by underlying networks using the appropriate Lustre network driver (LND). High availability and recovery features enable transparent recovery in conjunction with failover servers.

An LND is a pluggable driver that provides support for a particular network type, for example `ksocklnd` is the driver which implements the TCP Socket LND that supports TCP networks. LNDs are loaded into the driver stack, with one LND for each network type in use.

For information about configuring LNet, see Chapter 9, *Configuring Lustre Networking (LNet)*.

For information about administering LNet, see Part III, “Administering Lustre”.

2.2. Key Features of LNet

Key features of LNet include:

- RDMA, when supported by underlying networks
- Support for many commonly-used network types
- High availability and recovery
- Support of multiple network types simultaneously
- Routing among disparate networks

LNet permits end-to-end read/write throughput at or near peak bandwidth rates on a variety of network interconnects.

2.3. Lustre Networks

A Lustre network is comprised of clients and servers running the Lustre software. It need not be confined to one LNet subnet but can span several networks provided routing is possible between the networks. In a similar manner, a single network can have multiple LNet subnets.

The Lustre networking stack is comprised of two layers, the LNet code module and the LND. The LNet layer operates above the LND layer in a manner similar to the way the network layer operates above the data link layer. LNet layer is connectionless, asynchronous and does not verify that data has been transmitted while the LND layer is connection oriented and typically does verify data transmission.

LNets are uniquely identified by a label comprised of a string corresponding to an LND and a number, such as tcp0, o2ib0, or o2ib1, that uniquely identifies each LNet. Each node on an LNet has at least one network identifier (NID). A NID is a combination of the address of the network interface and the LNet label in the form:*address@LNet_label*.

Examples:

```
192.168.1.2@tcp0  
10.13.24.90@o2ib1
```

In certain circumstances it might be desirable for Lustre file system traffic to pass between multiple LNets. This is possible using LNet routing. It is important to realize that LNet routing is not the same as network routing. For more details about LNet routing, see Chapter 9, *Configuring Lustre Networking (LNet)*

2.4. Supported Network Types

The LNet code module includes LNDs to support many network types including:

- InfiniBand: OpenFabrics OFED (o2ib)
- TCP (any network carrying TCP traffic, including GigE, 10GigE, and IPoIB)
- RapidArray: ra
- Quadrics: Elan

Chapter 3. Understanding Failover in a Lustre File System

This chapter describes failover in a Lustre file system. It includes:

- Section 3.1, “What is Failover?”
- Section 3.2, “Failover Functionality in a Lustre File System”

3.1. What is Failover?

In a high-availability (HA) system, unscheduled downtime is minimized by using redundant hardware and software components and software components that automate recovery when a failure occurs. If a failure condition occurs, such as the loss of a server or storage device or a network or software fault, the system's services continue with minimal interruption. Generally, availability is specified as the percentage of time the system is required to be available.

Availability is accomplished by replicating hardware and/or software so that when a primary server fails or is unavailable, a standby server can be switched into its place to run applications and associated resources. This process, called *failover*, is automatic in an HA system and, in most cases, completely application-transparent.

A failover hardware setup requires a pair of servers with a shared resource (typically a physical storage device, which may be based on SAN, NAS, hardware RAID, SCSI or Fibre Channel (FC) technology). The method of sharing storage should be essentially transparent at the device level; the same physical logical unit number (LUN) should be visible from both servers. To ensure high availability at the physical storage level, we encourage the use of RAID arrays to protect against drive-level failures.

Note

The Lustre software does not provide redundancy for data; it depends exclusively on redundancy of backing storage devices. The backing OST storage should be RAID 5 or, preferably, RAID 6 storage. MDT storage should be RAID 1 or RAID 10.

3.1.1. Failover Capabilities

To establish a highly-available Lustre file system, power management software or hardware and high availability (HA) software are used to provide the following failover capabilities:

- **Resource fencing**- Protects physical storage from simultaneous access by two nodes.
- **Resource management**- Starts and stops the Lustre resources as a part of failover, maintains the cluster state, and carries out other resource management tasks.
- **Health monitoring**- Verifies the availability of hardware and network resources and responds to health indications provided by the Lustre software.

These capabilities can be provided by a variety of software and/or hardware solutions. For more information about using power management software or hardware and high availability (HA) software with a Lustre file system, see Chapter 11, *Configuring Failover in a Lustre File System*.

HA software is responsible for detecting failure of the primary Lustre server node and controlling the failover. The Lustre software works with any HA software that includes resource (I/O) fencing. For proper resource fencing, the HA software must be able to completely power off the failed server or disconnect it from the shared storage device. If two active nodes have access to the same storage device, data may be severely corrupted.

3.1.2. Types of Failover Configurations

Nodes in a cluster can be configured for failover in several ways. They are often configured in pairs (for example, two OSTs attached to a shared storage device), but other failover configurations are also possible. Failover configurations include:

- **Active/passive pair** - In this configuration, the active node provides resources and serves data, while the passive node is usually standing by idle. If the active node fails, the passive node takes over and becomes active.
- **Active/active pair** - In this configuration, both nodes are active, each providing a subset of resources. In case of a failure, the second node takes over resources from the failed node.

If there is a single MDT in a filesystem, two MDSes can be configured as an active/passive pair, while pairs of OSSes can be deployed in an active/active configuration that improves OST availability without extra overhead. Often the standby MDS is the active MDS for another Lustre file system or the MGS, so no nodes are idle in the cluster. If there are multiple MDTs in a filesystem, active-active failover configurations are available for MDSs that serve MDTs on shared storage.

3.2. Failover Functionality in a Lustre File System

The failover functionality provided by the Lustre software can be used for the following failover scenario. When a client attempts to do I/O to a failed Lustre target, it continues to try until it receives an answer from any of the configured failover nodes for the Lustre target. A user-space application does not detect anything unusual, except that the I/O may take longer to complete.

Failover in a Lustre file system requires that two nodes be configured as a failover pair, which must share one or more storage devices. A Lustre file system can be configured to provide MDT or OST failover.

- For MDT failover, two MDSs can be configured to serve the same MDT. Only one MDS node can serve any MDT at one time. By placing two or more MDT devices on storage shared by two MDSs, one MDS can fail and the remaining MDS can begin serving the unserved MDT. This is described as an active/active failover pair.
- For OST failover, multiple OSS nodes can be configured to be able to serve the same OST. However, only one OSS node can serve the OST at a time. An OST can be moved between OSS nodes that have access to the same storage device using `umount / mount` commands.

The `--servicenode` option is used to set up nodes in a Lustre file system for failover at creation time (using `mkfs.lustre`) or later when the Lustre file system is active (using `tunefs.lustre`). For explanations of these utilities, see Section 44.12, “`mkfs.lustre`” and Section 44.15, “`tunefs.lustre`”.

Failover capability in a Lustre file system can be used to upgrade the Lustre software between successive minor versions without cluster downtime. For more information, see Chapter 17, *Upgrading a Lustre File System*.

For information about configuring failover, see Chapter 11, *Configuring Failover in a Lustre File System*.

Note

The Lustre software provides failover functionality only at the file system level. In a complete failover solution, failover functionality for system-level components, such as node failure detection or power control, must be provided by a third-party tool.

Caution

OST failover functionality does not protect against corruption caused by a disk failure. If the storage media (i.e., physical disk) used for an OST fails, it cannot be recovered by functionality provided in the Lustre software. We strongly recommend that some form of RAID be used for OSTs. Lustre functionality assumes that the storage is reliable, so it adds no extra reliability features.

3.2.1. MDT Failover Configuration (Active/Passive)

Two MDSs are typically configured as an active/passive failover pair as shown in Figure 3.1, “Lustre failover configuration for a active/passive MDT”. Note that both nodes must have access to shared storage for the MDT(s) and the MGS. The primary (active) MDS manages the Lustre system metadata resources. If the primary MDS fails, the secondary (passive) MDS takes over these resources and serves the MDTs and the MGS.

Note

In an environment with multiple file systems, the MDSs can be configured in a quasi active/active configuration, with each MDS managing metadata for a subset of the Lustre file system.

Figure 3.1. Lustre failover configuration for a active/passive MDT

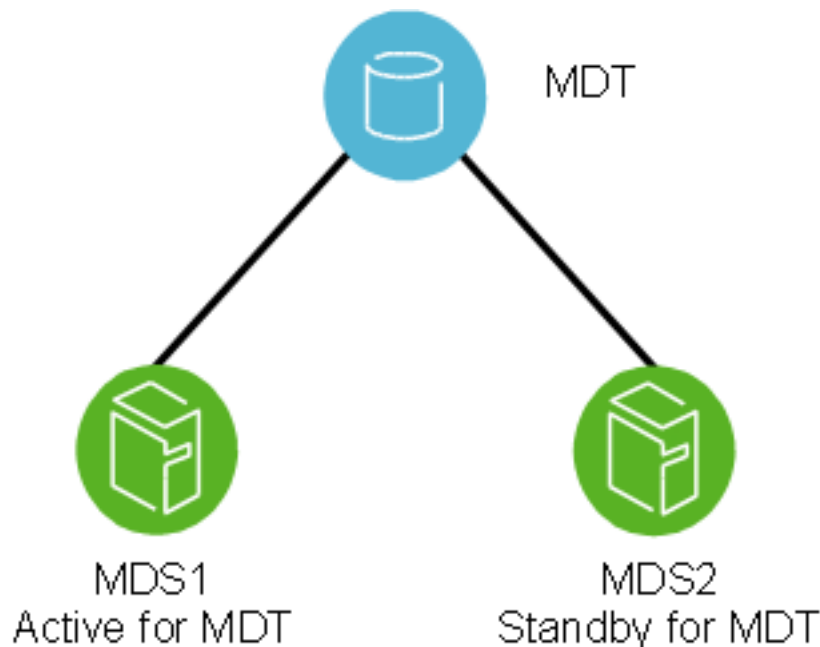

3.2.2. MDT Failover Configuration (Active/Active)

MDTs can be configured as an active/active failover configuration. A failover cluster is built from two MDSs as shown in Figure 3.2, “Lustre failover configuration for a active/active MDTs”.

Figure 3.2. Lustre failover configuration for a active/active MDTs

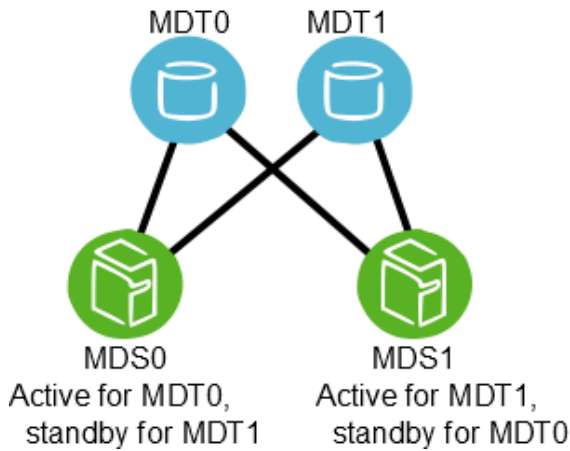

3.2.3. OST Failover Configuration (Active/Active)

OSTs are usually configured in a load-balanced, active/active failover configuration. A failover cluster is built from two OSSs as shown in Figure 3.3, “Lustre failover configuration for an OSTs”.

Note

OSSs configured as a failover pair must have shared disks/RAID.

Figure 3.3. Lustre failover configuration for an OSTs

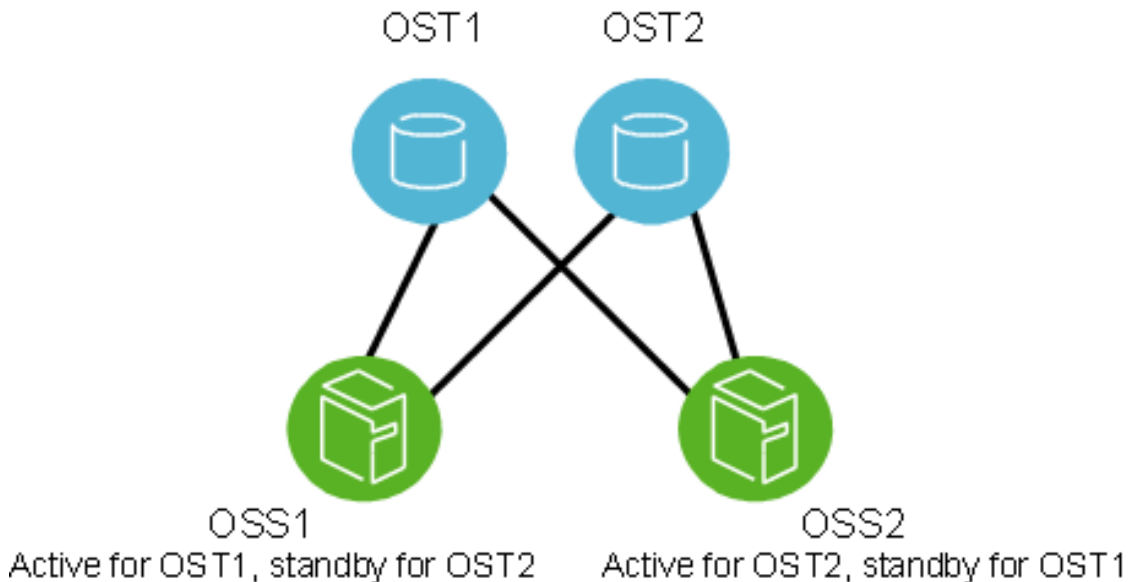

In an active configuration, 50% of the available OSTs are assigned to one OSS and the remaining OSTs are assigned to the other OSS. Each OSS serves as the primary node for half the OSTs and as a failover node for the remaining OSTs.

In this mode, if one OSS fails, the other OSS takes over all of the failed OSTs. The clients attempt to connect to each OSS serving the OST, until one of them responds. Data on the OST is written synchronously, and the clients replay transactions that were in progress and uncommitted to disk before the OST failure.

For more information about configuring failover, see Chapter 11, *Configuring Failover in a Lustre File System*.

Part II. Installing and Configuring Lustre

Part II describes how to install and configure a Lustre file system. You will find information in this section about:

- Installation Overview
 - Determining Hardware Configuration Requirements and Formatting Options
 - Configuring Storage on a Lustre File System
 - Setting Up Network Interface Bonding
 - Installing the Lustre Software
 - Configuring Lustre Networking (LNet)
 - Configuring a Lustre File System
 - Configuring Failover in a Lustre File System
-

Table of Contents

4. Installation Overview	24
4.1. Steps to Installing the Lustre Software	24
5. Determining Hardware Configuration Requirements and Formatting Options	25
5.1. Hardware Considerations	25
5.1.1. MGT and MDT Storage Hardware Considerations	26
5.1.2. OST Storage Hardware Considerations	27
5.2. Determining Space Requirements	27
5.2.1. Determining MGT Space Requirements	28
5.2.2. Determining MDT Space Requirements	28
5.2.3. Determining OST Space Requirements	29
5.3. Setting ldiskfs File System Formatting Options	29
5.3.1. Setting Formatting Options for an ldiskfs MDT	30
5.3.2. Setting Formatting Options for an ldiskfs OST	31
5.4. File and File System Limits	31
5.5. Determining Memory Requirements	35
5.5.1. Client Memory Requirements	35
5.5.2. MDS Memory Requirements	35
5.5.3. OSS Memory Requirements	36
5.6. Implementing Networks To Be Used by the Lustre File System	37
6. Configuring Storage on a Lustre File System	39
6.1. Selecting Storage for the MDT and OSTs	39
6.1.1. Metadata Target (MDT)	39
6.1.2. Object Storage Server (OST)	39
6.2. Reliability Best Practices	40
6.3. Performance Tradeoffs	40
6.4. Formatting Options for ldiskfs RAID Devices	40
6.4.1. Computing file system parameters for mkfs	41
6.4.2. Choosing Parameters for an External Journal	41
6.5. Connecting a SAN to a Lustre File System	42
7. Setting Up Network Interface Bonding	43
7.1. Network Interface Bonding Overview	43
7.2. Requirements	43
7.3. Bonding Module Parameters	44
7.4. Setting Up Bonding	45
7.4.1. Examples	47
7.5. Configuring a Lustre File System with Bonding	48
7.6. Bonding References	48
8. Installing the Lustre Software	50
8.1. Preparing to Install the Lustre Software	50
8.1.1. Software Requirements	50
8.1.2. Environmental Requirements	52
8.2. Lustre Software Installation Procedure	52
9. Configuring Lustre Networking (LNet)	55
9.1. Configuring LNet via <code>lnetctl</code>	L 2.7 55
9.1.1. Configuring LNet	56
9.1.2. Displaying Global Settings	56
9.1.3. Adding, Deleting and Showing Networks	56
9.1.4. Manual Adding, Deleting and Showing Peers	L 2.10 58
9.1.5. Dynamic Peer Discovery	L 2.11 60
9.1.6. Adding, Deleting and Showing routes	61
9.1.7. Enabling and Disabling Routing	62

9.1.8. Showing routing information	62
9.1.9. Configuring Routing Buffers	62
9.1.10. Asymmetrical Routes	L 2.13 63
9.1.11. Importing YAML Configuration File	64
9.1.12. Exporting Configuration in YAML format	64
9.1.13. Showing LNet Traffic Statistics	64
9.1.14. YAML Syntax	64
9.2. Overview of LNet Module Parameters	66
9.2.1. Using a Lustre Network Identifier (NID) to Identify a Node	66
9.3. Setting the LNet Module networks Parameter	67
9.3.1. Multihome Server Example	68
9.4. Setting the LNet Module ip2nets Parameter	68
9.5. Setting the LNet Module routes Parameter	70
9.5.1. Routing Example	70
9.6. Testing the LNet Configuration	70
9.7. Configuring the Router Checker	71
9.8. Best Practices for LNet Options	72
9.8.1. Escaping commas with quotes	72
9.8.2. Including comments	72
10. Configuring a Lustre File System	73
10.1. Configuring a Simple Lustre File System	73
10.1.1. Simple Lustre Configuration Example	76
10.2. Additional Configuration Options	81
10.2.1. Scaling the Lustre File System	81
10.2.2. Changing Striping Defaults	81
10.2.3. Using the Lustre Configuration Utilities	82
11. Configuring Failover in a Lustre File System	83
11.1. Setting Up a Failover Environment	83
11.1.1. Selecting Power Equipment	83
11.1.2. Selecting Power Management Software	83
11.1.3. Selecting High-Availability (HA) Software	84
11.2. Preparing a Lustre File System for Failover	84
11.3. Administering Failover in a Lustre File System	85

Chapter 4. Installation Overview

This chapter provides an overview of the procedures required to set up, install and configure a Lustre file system.

Note

If the Lustre file system is new to you, you may find it helpful to refer to Part I, “Introducing the Lustre* File System” for a description of the Lustre architecture, file system components and terminology before proceeding with the installation procedure.

4.1. Steps to Installing the Lustre Software

To set up Lustre file system hardware and install and configure the Lustre software, refer to the chapters below in the order listed:

1. *(Required)* **Set up your Lustre file system hardware.**

See Chapter 5, *Determining Hardware Configuration Requirements and Formatting Options* - Provides guidelines for configuring hardware for a Lustre file system including storage, memory, and networking requirements.

2. *(Optional - Highly Recommended)* **Configure storage on Lustre storage devices.**

See Chapter 6, *Configuring Storage on a Lustre File System* - Provides instructions for setting up hardware RAID on Lustre storage devices.

3. *(Optional)* **Set up network interface bonding.**

See Chapter 7, *Setting Up Network Interface Bonding* - Describes setting up network interface bonding to allow multiple network interfaces to be used in parallel to increase bandwidth or redundancy.

4. *(Required)* **Install Lustre software.**

See Chapter 8, *Installing the Lustre Software* - Describes preparation steps and a procedure for installing the Lustre software.

5. *(Optional)* **Configure Lustre Networking (LNet).**

See Chapter 9, *Configuring Lustre Networking (LNet)* - Describes how to configure LNet if the default configuration is not sufficient. By default, LNet will use the first TCP/IP interface it discovers on a system. LNet configuration is required if you are using InfiniBand or multiple Ethernet interfaces.

6. *(Required)* **Configure the Lustre file system.**

See Chapter 10, *Configuring a Lustre File System* - Provides an example of a simple Lustre configuration procedure and points to tools for completing more complex configurations.

7. *(Optional)* **Configure Lustre failover.**

See Chapter 11, *Configuring Failover in a Lustre File System* - Describes how to configure Lustre failover.

Chapter 5. Determining Hardware Configuration Requirements and Formatting Options

This chapter describes hardware configuration requirements for a Lustre file system including:

- Section 5.1, “Hardware Considerations”
- Section 5.2, “Determining Space Requirements”
- Section 5.3, “Setting ldiskfs File System Formatting Options”
- Section 5.5, “Determining Memory Requirements”
- Section 5.6, “Implementing Networks To Be Used by the Lustre File System”

5.1. Hardware Considerations

A Lustre file system can utilize any kind of block storage device such as single disks, software RAID, hardware RAID, or a logical volume manager. In contrast to some networked file systems, the block devices are only attached to the MDS and OSS nodes in a Lustre file system and are not accessed by the clients directly.

Since the block devices are accessed by only one or two server nodes, a storage area network (SAN) that is accessible from all the servers is not required. Expensive switches are not needed because point-to-point connections between the servers and the storage arrays normally provide the simplest and best attachments. (If failover capability is desired, the storage must be attached to multiple servers.)

For a production environment, it is preferable that the MGS have separate storage to allow future expansion to multiple file systems. However, it is possible to run the MDS and MGS on the same machine and have them share the same storage device.

For best performance in a production environment, dedicated clients are required. For a non-production Lustre environment or for testing, a Lustre client and server can run on the same machine. However, dedicated clients are the only supported configuration.

Warning

Performance and recovery issues can occur if you put a client on an MDS or OSS:

- Running the OSS and a client on the same machine can cause issues with low memory and memory pressure. If the client consumes all the memory and then tries to write data to the file system, the OSS will need to allocate pages to receive data from the client but will not be able to perform this operation due to low memory. This can cause the client to hang.
- Running the MDS and a client on the same machine can cause recovery and deadlock issues and impact the performance of other Lustre clients.

Only servers running on 64-bit CPUs are tested and supported. 64-bit CPU clients are typically used for testing to match expected customer usage and avoid limitations due to the 4 GB limit for RAM size, 1 GB low-memory limitation, and 16 TB file size limit of 32-bit CPUs. Also, due to kernel API limitations,

performing backups of Lustre filesystems on 32-bit clients may cause backup tools to confuse files that report the same 32-bit inode number, if the backup tools depend on the inode number for correct operation.

The storage attached to the servers typically uses RAID to provide fault tolerance and can optionally be organized with logical volume management (LVM), which is then formatted as a Lustre file system. Lustre OSS and MDS servers read, write and modify data in the format imposed by the file system.

The Lustre file system uses journaling file system technology on both the MDTs and OSTs. For a MDT, as much as a 20 percent performance gain can be obtained by placing the journal on a separate device.

The MDS can effectively utilize a lot of CPU cycles. A minimum of four processor cores are recommended. More are advisable for files systems with many clients.

Note

Lustre clients running on different CPU architectures is supported. One limitation is that the `PAGE_SIZE` kernel macro on the client must be as large as the `PAGE_SIZE` of the server. In particular, ARM or PPC clients with large pages (up to 64kB pages) can run with x86 servers (4kB pages).

5.1.1. MGT and MDT Storage Hardware Considerations

MGT storage requirements are small (less than 100 MB even in the largest Lustre file systems), and the data on an MGT is only accessed on a server/client mount, so disk performance is not a consideration. However, this data is vital for file system access, so the MGT should be reliable storage, preferably mirrored RAID1.

MDS storage is accessed in a database-like access pattern with many seeks and read-and-writes of small amounts of data. Storage types that provide much lower seek times, such as SSD or NVMe is strongly preferred for the MDT, and high-RPM SAS is acceptable.

For maximum performance, the MDT should be configured as RAID1 with an internal journal and two disks from different controllers.

If you need a larger MDT, create multiple RAID1 devices from pairs of disks, and then make a RAID0 array of the RAID1 devices. For ZFS, use `mirror VDEVs` for the MDT. This ensures maximum reliability because multiple disk failures only have a small chance of hitting both disks in the same RAID1 device.

Doing the opposite (RAID1 of a pair of RAID0 devices) has a 50% chance that even two disk failures can cause the loss of the whole MDT device. The first failure disables an entire half of the mirror and the second failure has a 50% chance of disabling the remaining mirror.

If multiple MDTs are going to be present in the system, each MDT should be specified for the anticipated usage and load. For details on how to add additional MDTs to the filesystem, see Section 14.7, “Adding a New MDT to a Lustre File System”.

Warning

MDT0000 contains the root of the Lustre file system. If MDT0000 is unavailable for any reason, the file system cannot be used.

Note

Using the DNE feature it is possible to dedicate additional MDTs to sub-directories off the file system root directory stored on MDT0000, or arbitrarily for lower-level subdirectories, using the `lfs mkdir -i mdt_index` command. If an MDT serving a subdirectory becomes

unavailable, any subdirectories on that MDT and all directories beneath it will also become inaccessible. This is typically useful for top-level directories to assign different users or projects to separate MDTs, or to distribute other large working sets of files to multiple MDTs.

Introduced in Lustre 2.8

Note

Starting in the 2.8 release it is possible to spread a single large directory across multiple MDTs using the DNE striped directory feature by specifying multiple stripes (or shards) at creation time using the `lfs mkdir -c stripe_count` command, where *stripe_count* is often the number of MDTs in the filesystem. Striped directories *should not be used for all directories in the filesystem*, since this incurs extra overhead compared to unstriped directories. This is intended for specific applications where many output files are being created in one large directory (over 50k entries).

5.1.2. OST Storage Hardware Considerations

The data access pattern for the OSS storage is a streaming I/O pattern that is dependent on the access patterns of applications being used. Each OSS can manage multiple object storage targets (OSTs), one for each volume with I/O traffic load-balanced between servers and targets. An OSS should be configured to have a balance between the network bandwidth and the attached storage bandwidth to prevent bottlenecks in the I/O path. Depending on the server hardware, an OSS typically serves between 2 and 8 targets, with each target between 24-48TB, but may be up to 256 terabytes (TBs) in size.

Lustre file system capacity is the sum of the capacities provided by the targets. For example, 64 OSSs, each with two 8 TB OSTs, provide a file system with a capacity of nearly 1 PB. If each OST uses ten 1 TB SATA disks (8 data disks plus 2 parity disks in a RAID-6 configuration), it may be possible to get 50 MB/sec from each drive, providing up to 400 MB/sec of disk bandwidth per OST. If this system is used as storage backend with a system network, such as the InfiniBand network, that provides a similar bandwidth, then each OSS could provide 800 MB/sec of end-to-end I/O throughput. (Although the architectural constraints described here are simple, in practice it takes careful hardware selection, benchmarking and integration to obtain such results.)

5.2. Determining Space Requirements

The desired performance characteristics of the backing file systems on the MDT and OSTs are independent of one another. The size of the MDT backing file system depends on the number of inodes needed in the total Lustre file system, while the aggregate OST space depends on the total amount of data stored on the file system. If MGS data is to be stored on the MDT device (co-located MGT and MDT), add 100 MB to the required size estimate for the MDT.

Each time a file is created on a Lustre file system, it consumes one inode on the MDT and one OST object over which the file is striped. Normally, each file's stripe count is based on the system-wide default stripe count. However, this can be changed for individual files using the `lfs setstripe` option. For more details, see Chapter 19, *Managing File Layout (Striping) and Free Space*.

In a Lustre `ldiskfs` file system, all the MDT inodes and OST objects are allocated when the file system is first formatted. When the file system is in use and a file is created, metadata associated with that file is stored in one of the pre-allocated inodes and does not consume any of the free space used to store file data. The total number of inodes on a formatted `ldiskfs` MDT or OST cannot be easily changed. Thus, the number of inodes created at format time should be generous enough to anticipate near term expected usage, with some room for growth without the effort of additional storage.

By default, the `ldiskfs` file system used by Lustre servers to store user-data objects and system data reserves 5% of space that cannot be used by the Lustre file system. Additionally, an `ldiskfs` Lustre file system reserves up to 400 MB on each OST, and up to 4GB on each MDT for journal use and a small amount of space outside the journal to store accounting data. This reserved space is unusable for general storage. Thus, at least this much space will be used per OST before any file object data is saved.

With a ZFS backing filesystem for the MDT or OST, the space allocation for inodes and file data is dynamic, and inodes are allocated as needed. A minimum of 4kB of usable space (before mirroring) is needed for each inode, exclusive of other overhead such as directories, internal log files, extended attributes, ACLs, etc. ZFS also reserves approximately 3% of the total storage space for internal and redundant metadata, which is not usable by Lustre. Since the size of extended attributes and ACLs is highly dependent on kernel versions and site-specific policies, it is best to over-estimate the amount of space needed for the desired number of inodes, and any excess space will be utilized to store more inodes.

5.2.1. Determining MGT Space Requirements

Less than 100 MB of space is typically required for the MGT. The size is determined by the total number of servers in the Lustre file system cluster(s) that are managed by the MGS.

5.2.2. Determining MDT Space Requirements

When calculating the MDT size, the important factor to consider is the number of files to be stored in the file system, which depends on at least 2 KiB per inode of usable space on the MDT. Since MDTs typically use RAID-1+0 mirroring, the total storage needed will be double this.

Please note that the actual used space per MDT depends on the number of files per directory, the number of stripes per file, whether files have ACLs or user xattrs, and the number of hard links per file. The storage required for Lustre file system metadata is typically 1-2 percent of the total file system capacity depending upon file size. If the Chapter 20, *Data on MDT (DoM)* feature is in use for Lustre 2.11 or later, MDT space should typically be 5 percent or more of the total space, depending on the distribution of small files within the filesystem and the `lod.*.dom_stripesize` limit on the MDT and file layout used.

For ZFS-based MDT filesystems, the number of inodes created on the MDT and OST is dynamic, so there is less need to determine the number of inodes in advance, though there still needs to be some thought given to the total MDT space compared to the total filesystem size.

For example, if the average file size is 5 MiB and you have 100 TiB of usable OST space, then you can calculate the *minimum* total number of inodes for MDTs and OSTs as follows:

$(500 \text{ TB} * 1000000 \text{ MB/TB}) / 5 \text{ MB/inode} = 100\text{M inodes}$

It is recommended that the MDT(s) have at least twice the minimum number of inodes to allow for future expansion and allow for an average file size smaller than expected. Thus, the minimum space for `ldiskfs` MDT(s) should be approximately:

$2 \text{ KiB/inode} * 100 \text{ million inodes} * 2 = 400 \text{ GiB ldiskfs MDT}$

For details about formatting options for `ldiskfs` MDT and OST file systems, see Section 5.3.1, “Setting Formatting Options for an `ldiskfs` MDT”.

Note

If the median file size is very small, 4 KB for example, the MDT would use as much space for each file as the space used on the OST, so the use of Data-on-MDT is strongly recommended

in that case. The MDT space per inode should be increased correspondingly to account for the extra data space usage for each inode:

6 KiB/inode x 100 million inodes x 2 = 1200 GiB ldiskfs MDT

Note

If the MDT has too few inodes, this can cause the space on the OSTs to be inaccessible since no new files can be created. In this case, the `lfs df -i` and `df -i` commands will limit the number of available inodes reported for the filesystem to match the total number of available objects on the OSTs. Be sure to determine the appropriate MDT size needed to support the filesystem before formatting. It is possible to increase the number of inodes after the file system is formatted, depending on the storage. For ldiskfs MDT filesystems the `resize2fs` tool can be used if the underlying block device is on a LVM logical volume and the underlying logical volume size can be increased. For ZFS new (mirrored) VDEVs can be added to the MDT pool to increase the total space available for inode storage. Inodes will be added approximately in proportion to space added.

Note

Note that the number of total and free inodes reported by `lfs df -i` for ZFS MDTs and OSTs is estimated based on the current average space used per inode. When a ZFS filesystem is first formatted, this free inode estimate will be very conservative (low) due to the high ratio of directories to regular files created for internal Lustre metadata storage, but this estimate will improve as more files are created by regular users and the average file size will better reflect actual site usage.

Note

Using the DNE remote directory feature it is possible to increase the total number of inodes of a Lustre filesystem, as well as increasing the aggregate metadata performance, by configuring additional MDTs into the filesystem, see Section 14.7, “Adding a New MDT to a Lustre File System” for details.

5.2.3. Determining OST Space Requirements

For the OST, the amount of space taken by each object depends on the usage pattern of the users/applications running on the system. The Lustre software defaults to a conservative estimate for the average object size (between 64 KiB per object for 10 GiB OSTs, and 1 MiB per object for 16 TiB and larger OSTs). If you are confident that the average file size for your applications will be different than this, you can specify a different average file size (number of total inodes for a given OST size) to reduce file system overhead and minimize file system check time. See Section 5.3.2, “Setting Formatting Options for an ldiskfs OST” for more details.

5.3. Setting ldiskfs File System Formatting Options

By default, the `mkfs.lustre` utility applies these options to the Lustre backing file system used to store data and metadata in order to enhance Lustre file system performance and scalability. These options include:

- `flex_bg` - When the flag is set to enable this flexible-block-groups feature, block and inode bitmaps for multiple groups are aggregated to minimize seeking when bitmaps are read or written and to reduce read/modify/write operations on typical RAID storage (with 1 MiB RAID stripe widths). This flag is enabled on both OST and MDT file systems. On MDT file systems the `flex_bg` factor is left at the default value of 16. On OSTs, the `flex_bg` factor is set to 256 to allow all of the block or inode bitmaps in a single `flex_bg` to be read or written in a single 1MiB I/O typical for RAID storage.
- `huge_file` - Setting this flag allows files on OSTs to be larger than 2 TiB in size.
- `lazy_journal_init` - This extended option is enabled to prevent a full overwrite to zero out the large journal that is allocated by default in a Lustre file system (up to 400 MiB for OSTs, up to 4GiB for MDTs), to reduce the formatting time.

To override the default formatting options, use arguments to `mkfs.lustre` to pass formatting options to the backing file system:

```
--mkfsoptions='backing fs options'
```

For other `mkfs.lustre` options, see the Linux man page for `mke2fs(8)`.

5.3.1. Setting Formatting Options for an `ldiskfs` MDT

The number of inodes on the MDT is determined at format time based on the total size of the file system to be created. The default *bytes-per-inode* ratio ("inode ratio") for an `ldiskfs` MDT is optimized at one inode for every 2560 bytes of file system space.

This setting takes into account the space needed for additional `ldiskfs` filesystem-wide metadata, such as the journal (up to 4 GB), bitmaps, and directories, as well as files that Lustre uses internally to maintain cluster consistency. There is additional per-file metadata such as file layout for files with a large number of stripes, Access Control Lists (ACLs), and user extended attributes.

Introduced in Lustre 2.11

Starting in Lustre 2.11, the Chapter 20, *Data on MDT (DoM)* (DoM) feature allows storing small files on the MDT to take advantage of high-performance flash storage, as well as reduce space and network overhead. If you are planning to use the DoM feature with an `ldiskfs` MDT, it is recommended to *increase* the bytes-per-inode ratio to have enough space on the MDT for small files, as described below.

It is possible to change the recommended default of 2560 bytes per inode for an `ldiskfs` MDT when it is first formatted by adding the `--mkfsoptions="-i bytes-per-inode"` option to `mkfs.lustre`. Decreasing the inode ratio tunable `bytes-per-inode` will create more inodes for a given MDT size, but will leave less space for extra per-file metadata and is not recommended. The inode ratio must always be strictly larger than the MDT inode size, which is 1024 bytes by default. It is recommended to use an inode ratio at least 1536 bytes larger than the inode size to ensure the MDT does not run out of space. Increasing the inode ratio with enough space for the most commonly file size (e.g. 5632 or 66560 bytes if 4KB or 64KB files are widely used) is recommended for DoM.

The size of the inode may be changed at format time by adding the `--stripe-count-hint=N` to have `mkfs.lustre` automatically calculate a reasonable inode size based on the default stripe count that will be used by the filesystem, or directly by specifying the `--mkfsoptions="-I inode-size"` option. Increasing the inode size will provide more space in the inode for a larger Lustre file layout, ACLs, user and system extended attributes, SELinux and other security labels, and other internal metadata and DoM data. However, if these features or other in-inode xattrs are not needed, a larger inode size may hurt metadata performance as 2x, 4x, or 8x as much data would be read or written for each MDT inode access.

5.3.2. Setting Formatting Options for an Ldiskfs OST

When formatting an OST file system, it can be beneficial to take local file system usage into account, for example by running `df` and `df -i` on a current filesystem to get the used bytes and used inodes respectively, then computing the average bytes-per-inode value. When deciding on the ratio for a new filesystem, try to avoid having too many inodes on each OST, while keeping enough margin to allow for future usage of smaller files. This helps reduce the format and `e2fsck` time and makes more space available for data.

The table below shows the default *bytes-per-inode* ratio ("inode ratio") used for OSTs of various sizes when they are formatted.

Table 5.1. Default Inode Ratios Used for Newly Formatted OSTs

LUN/OST size	Default Inode ratio	Total inodes
under 10GiB	1 inode/16KiB	640 - 655k
10GiB - 1TiB	1 inode/68KiB	153k - 15.7M
1TiB - 8TiB	1 inode/256KiB	4.2M - 33.6M
over 8TiB	1 inode/1MiB	8.4M - 268M

In environments with few small files, the default inode ratio may result in far too many inodes for the average file size. In this case, performance can be improved by increasing the number of *bytes-per-inode*. To set the inode ratio, use the `--mkfsoptions="-i bytes-per-inode"` argument to `mkfs.lustre` to specify the expected average (mean) size of OST objects. For example, to create an OST with an expected average object size of 8 MiB run:

```
[oss#] mkfs.lustre --ost --mkfsoptions="-i $((8192 * 1024))" ...
```

Note

OSTs formatted with `ldiskfs` should preferably have fewer than 320 million objects per MDT, and up to a maximum of 4 billion inodes. Specifying a very small bytes-per-inode ratio for a large OST that exceeds this limit can cause either premature out-of-space errors and prevent the full OST space from being used, or will waste space and slow down `e2fsck` more than necessary. The default inode ratios are chosen to ensure the total number of inodes remain below this limit.

Note

File system check time on OSTs is affected by a number of variables in addition to the number of inodes, including the size of the file system, the number of allocated blocks, the distribution of allocated blocks on the disk, disk speed, CPU speed, and the amount of RAM on the server. Reasonable file system check times for valid filesystems are 5-30 minutes per TiB, but may increase significantly if substantial errors are detected and need to be repaired.

For further details about optimizing MDT and OST file systems, see Section 6.4, “Formatting Options for Ldiskfs RAID Devices”.

5.4. File and File System Limits

Table 5.2, “File and file system limits” describes current known limits of Lustre. These limits may be imposed by either the Lustre architecture or the Linux virtual file system (VFS) and virtual memory

subsystems. In a few cases, a limit is defined within the code Lustre based on tested values and could be changed by editing and re-compiling the Lustre software. In these cases, the indicated limit was used for testing of the Lustre software.

Table 5.2. File and file system limits

Limit	Value	Description
Maximum number of MDTs	256	A single MDS can host one or more MDTs, either for separate filesystems, or aggregated into a single namespace. Each filesystem requires a separate MDT for the filesystem root directory. Up to 255 more MDTs can be added to the filesystem and are attached into the filesystem namespace with creation of DNE remote or striped directories.
Maximum number of OSTs	8150	The maximum number of OSTs is a constant that can be changed at compile time. Lustre file systems with up to 4000 OSTs have been configured in the past. Multiple OST targets can be configured on a single OSS node.
Maximum OST size	1024TiB (ldiskfs), 1024TiB (ZFS)	This is not a <i>hard</i> limit. Larger OSTs are possible, but most production systems do not typically go beyond the stated limit per OST because Lustre can add capacity and performance with additional OSTs, and having more OSTs improves aggregate I/O performance, minimizes contention, and allows parallel recovery (e2fsck for ldiskfs OSTs, scrub for ZFS OSTs). With 32-bit kernels, due to page cache limits, 16TB is the maximum block device size, which in turn applies to the size of OST. It is <i>strongly</i> recommended to run Lustre clients and servers with 64-bit kernels.
Maximum number of clients	131072	The maximum number of clients is a constant that can be changed at compile time. Up to 30000 clients have been used in production accessing a single filesystem.
Maximum size of a single file system	2EiB or larger	Each OST can have a file system up to the "Maximum OST size" limit, and the Maximum number of OSTs can be combined into a single filesystem.
Maximum stripe count	2000	This limit is imposed by the size of the layout that needs to be stored on disk and sent in RPC requests, but is not a hard limit of the protocol. The number of OSTs in the filesystem can exceed the stripe count, but this is the maximum number of OSTs on which a <i>single file</i> can be striped.

Introduced in Lustre 2.13

Determining Hardware Configuration
Requirements and Formatting Options

Limit	Value	Description
		<p>Note</p> <p>Before 2.13, the default for <code>ldiskfs</code> MDTs the maximum stripe count for a <i>single file</i> is limited to 160 OSTs. In order to increase the maximum file stripe count, use <code>--mkfsoptions="-O ea_inode"</code> when formatting the MDT, or use <code>tune2fs -O ea_inode</code> to enable it after the MDT has been formatted.</p>
Maximum stripe size	< 4 GiB	The amount of data written to each object before moving on to next object.
Minimum stripe size	64 KiB	Due to the use of 64 KiB <code>PAGE_SIZE</code> on some CPU architectures such as ARM and POWER, the minimum stripe size is 64 KiB so that a single page is not split over multiple servers. This is also the minimum Data-on-MDT component size that can be specified.
Maximum single object size	16TiB (ldiskfs), 256TiB (ZFS)	The amount of data that can be stored in a single object. An object corresponds to a stripe. The <code>ldiskfs</code> limit of 16 TB for a single object applies. For ZFS the limit is the size of the underlying OST. Files can consist of up to 2000 stripes, each stripe can be up to the maximum object size.
Maximum file size	16 TiB on 32-bit systems 31.25 PiB on 64-bit <code>ldiskfs</code> systems, 8EiB on 64-bit ZFS systems	<p>Individual files have a hard limit of nearly 16 TiB on 32-bit systems imposed by the kernel memory subsystem. On 64-bit systems this limit does not exist. Hence, files can be 2^{63} bits (8EiB) in size if the backing filesystem can support large enough objects and/or the files are sparse.</p> <p>A single file can have a maximum of 2000 stripes, which gives an upper single file data capacity of 31.25 PiB for 64-bit <code>ldiskfs</code> systems. The actual amount of data that can be stored in a file depends upon the amount of free space in each OST on which the file is striped.</p>
Maximum number of files or subdirectories in a single directory	600M-3.8B files (ldiskfs), 16T (ZFS)	The Lustre software uses the <code>ldiskfs</code> hashed directory code, which has a limit of at least 600 million files, depending on the length of the file name. The limit on subdirectories is the same as the limit on regular files.

Introduced in Lustre 2.8

Limit	Value	Description
		<p>Note</p> <p>Starting in the 2.8 release it is possible to exceed this limit by striping a single directory over multiple MDTs with the <code>lfs mkdir -c</code> command, which increases the single directory limit by a factor of the number of directory stripes used.</p> <p>Introduced in Lustre 2.12</p> <p>Note</p> <p>In the 2.12 release, the <code>large_dir</code> feature of <code>ldiskfs</code> was added to allow the use of directories over 10M entries, but not enabled by default.</p> <p>Introduced in Lustre 2.14</p> <p>Note</p> <p>Starting in the 2.14 release, the <code>large_dir</code> feature is enabled by default.</p>
Maximum number of files in the file system	4 billion (ldiskfs), 256 trillion (ZFS) <i>per MDT</i>	<p>The <code>ldiskfs</code> filesystem imposes an upper limit of 4 billion inodes per filesystem. By default, the MDT filesystem is formatted with one inode per 2KB of space, meaning 512 million inodes per TiB of MDT space. This can be increased initially at the time of MDT filesystem creation. For more information, see Chapter 5, <i>Determining Hardware Configuration Requirements and Formatting Options</i>.</p> <p>The ZFS filesystem dynamically allocates inodes and does not have a fixed ratio of inodes per unit of MDT space, but consumes approximately 4KiB of mirrored space per inode, depending on the configuration.</p> <p>Each additional MDT can hold up to the above maximum number of additional files, depending on available space and the distribution directories and files in the filesystem.</p>

Limit	Value	Description
Maximum length of a filename	255 bytes (filename)	This limit is 255 bytes for a single filename, the same as the limit in the underlying filesystems.
Maximum length of a pathname	4096 bytes (pathname)	The Linux VFS imposes a full pathname length of 4096 bytes.
Maximum number of open files for a Lustre file system	No limit	The Lustre software does not impose a maximum for the number of open files, but the practical limit depends on the amount of RAM on the MDS. No "tables" for open files exist on the MDS, as they are only linked in a list to a given client's export. Each client process has a limit of several thousands of open files which depends on its ulimit.

5.5. Determining Memory Requirements

This section describes the memory requirements for each Lustre file system component.

5.5.1. Client Memory Requirements

A minimum of 2 GB RAM is recommended for clients.

5.5.2. MDS Memory Requirements

MDS memory requirements are determined by the following factors:

- Number of clients
- Size of the directories
- Load placed on server

The amount of memory used by the MDS is a function of how many clients are on the system, and how many files they are using in their working set. This is driven, primarily, by the number of locks a client can hold at one time. The number of locks held by clients varies by load and memory availability on the server. Interactive clients can hold in excess of 10,000 locks at times. On the MDS, memory usage is approximately 2 KB per file, including the Lustre distributed lock manager (LDLM) lock and kernel data structures for the files currently in use. Having file data in cache can improve metadata performance by a factor of 10x or more compared to reading it from storage.

MDS memory requirements include:

- **File system metadata:** A reasonable amount of RAM needs to be available for file system metadata. While no hard limit can be placed on the amount of file system metadata, if more RAM is available, then the disk I/O is needed less often to retrieve the metadata.
- **Network transport:** If you are using TCP or other network transport that uses system memory for send/receive buffers, this memory requirement must also be taken into consideration.

- **Journal size:** By default, the journal size is 4096 MB for each MDT `ldiskfs` file system. This can pin up to an equal amount of RAM on the MDS node per file system.
- **Failover configuration:** If the MDS node will be used for failover from another node, then the RAM for each journal should be doubled, so the backup server can handle the additional load if the primary server fails.

5.5.2.1. Calculating MDS Memory Requirements

By default, 4096 MB are used for the `ldiskfs` filesystem journal. Additional RAM is used for caching file data for the larger working set, which is not actively in use by clients but should be kept "hot" for improved access times. Approximately 1.5 KB per file is needed to keep a file in cache without a lock.

For example, for a single MDT on an MDS with 1,024 compute nodes, 12 interactive login nodes, and a 20 million file working set (of which 9 million files are cached on the clients at one time):

Operating system overhead = 4096 MB (RHEL8)

File system journal = 4096 MB

$1024 * 32\text{-core clients} * 256 \text{ files/core} * 2\text{KB} = 16384 \text{ MB}$

$12 \text{ interactive clients} * 100,000 \text{ files} * 2\text{KB} = 2400 \text{ MB}$

$20 \text{ million file working set} * 1.5\text{KB/file} = 30720 \text{ MB}$

Thus, a reasonable MDS configuration for this workload is at least 60 GB of RAM. For active-active DNE MDT failover pairs, each MDS should have at least 96 GB of RAM. The additional memory can be used during normal operation to allow more metadata and locks to be cached and improve performance, depending on the workload.

For directories containing 1 million or more files, more memory can provide a significant benefit. For example, in an environment where clients randomly a single directory with 10 million files can consume as much as 35GB of RAM on the MDS.

5.5.3. OSS Memory Requirements

When planning the hardware for an OSS node, consider the memory usage of several components in the Lustre file system (i.e., journal, service threads, file system metadata, etc.). Also, consider the effect of the OSS read cache feature, which consumes memory as it caches data on the OSS node.

In addition to the MDS memory requirements mentioned above, the OSS requirements also include:

- **Service threads:** The service threads on the OSS node pre-allocate an RPC-sized MB I/O buffer for each `ost_io` service thread, so these large buffers do not need to be allocated and freed for each I/O request.
- **OSS read cache:** OSS read cache provides read-only caching of data on an HDD-based OSS, using the regular Linux page cache to store the data. Just like caching from a regular file system in the Linux operating system, OSS read cache uses as much physical memory as is available.

The same calculation applies to files accessed from the OSS as for the MDS, but the load is typically distributed over more OSS nodes, so the amount of memory required for locks, inode cache, etc. listed for the MDS is spread out over the OSS nodes.

Because of these memory requirements, the following calculations should be taken as determining the minimum RAM required in an OSS node.

5.5.3.1. Calculating OSS Memory Requirements

The minimum recommended RAM size for an OSS with eight OSTs, handling objects for 1/4 of the active files for the MDS:

Linux kernel and userspace daemon memory = 4096 MB

Network send/receive buffers (16 MB * 512 threads) = 8192 MB

1024 MB ldiskfs journal size * 8 OST devices = 8192 MB

16 MB read/write buffer per OST IO thread * 512 threads = 8192 MB

2048 MB file system read cache * 8 OSTs = 16384 MB

1024 * 32-core clients * 64 objects/core * 2KB/object = 4096 MB

12 interactive clients * 25,000 objects * 2KB/object = 600 MB

5 million object working set * 1.5KB/object = 7500 MB

For a non-failover configuration, the minimum RAM would be about 60 GB for an OSS node with eight OSTs. Additional memory on the OSS will improve the performance of reading smaller, frequently-accessed files.

For a failover configuration, the minimum RAM would be about 90 GB, as some of the memory is per-node. When the OSS is not handling any failed-over OSTs the extra RAM will be used as a read cache.

As a reasonable rule of thumb, about 24 GB of base memory plus 4 GB per OST can be used. In failover configurations, about 8 GB per primary OST is needed.

5.6. Implementing Networks To Be Used by the Lustre File System

As a high performance file system, the Lustre file system places heavy loads on networks. Thus, a network interface in each Lustre server and client is commonly dedicated to Lustre file system traffic. This is often a dedicated TCP/IP subnet, although other network hardware can also be used.

A typical Lustre file system implementation may include the following:

- A high-performance backend network for the Lustre servers, typically an InfiniBand (IB) network.
- A larger client network.
- Lustre routers to connect the two networks.

Lustre networks and routing are configured and managed by specifying parameters to the Lustre Networking (lnet) module in `/etc/modprobe.d/lustre.conf`.

To prepare to configure Lustre networking, complete the following steps:

1. **Identify all machines that will be running Lustre software and the network interfaces they will use to run Lustre file system traffic. These machines will form the Lustre network .**

A network is a group of nodes that communicate directly with one another. The Lustre software includes Lustre network drivers (LNDs) to support a variety of network types and hardware (see

Chapter 2, *Understanding Lustre Networking (LNet)* for a complete list). The standard rules for specifying networks applies to Lustre networks. For example, two TCP networks on two different subnets (`tcp0` and `tcp1`) are considered to be two different Lustre networks.

2. If routing is needed, identify the nodes to be used to route traffic between networks.

If you are using multiple network types, then you will need a router. Any node with appropriate interfaces can route Lustre networking (LNet) traffic between different network hardware types or topologies --the node may be a server, a client, or a standalone router. LNet can route messages between different network types (such as TCP-to-InfiniBand) or across different topologies (such as bridging two InfiniBand or TCP/IP networks). Routing will be configured in Chapter 9, *Configuring Lustre Networking (LNet)*.

3. Identify the network interfaces to include in or exclude from LNet.

If not explicitly specified, LNet uses either the first available interface or a pre-defined default for a given network type. Interfaces that LNet should not use (such as an administrative network or IP-over-IB), can be excluded.

Network interfaces to be used or excluded will be specified using the `lnet` kernel module parameters `networks` and `ip2nets` as described in Chapter 9, *Configuring Lustre Networking (LNet)*.

4. To ease the setup of networks with complex network configurations, determine a cluster-wide module configuration.

For large clusters, you can configure the networking setup for all nodes by using a single, unified set of parameters in the `lustre.conf` file on each node. Cluster-wide configuration is described in Chapter 9, *Configuring Lustre Networking (LNet)*.

Note

We recommend that you use 'dotted-quad' notation for IP addresses rather than host names to make it easier to read debug logs and debug configurations with multiple interfaces.

Chapter 6. Configuring Storage on a Lustre File System

This chapter describes best practices for storage selection and file system options to optimize performance on RAID, and includes the following sections:

- Section 6.1, “Selecting Storage for the MDT and OSTs”
- Section 6.2, “Reliability Best Practices”
- Section 6.3, “Performance Tradeoffs”
- Section 6.4, “Formatting Options for ldiskfs RAID Devices”
- Section 6.5, “Connecting a SAN to a Lustre File System”

Note

It is strongly recommended that storage used in a Lustre file system be configured with hardware RAID. The Lustre software does not support redundancy at the file system level and RAID is required to protect against disk failure.

6.1. Selecting Storage for the MDT and OSTs

The Lustre architecture allows the use of any kind of block device as backend storage. The characteristics of such devices, particularly in the case of failures, vary significantly and have an impact on configuration choices.

This section describes issues and recommendations regarding backend storage.

6.1.1. Metadata Target (MDT)

I/O on the MDT is typically mostly reads and writes of small amounts of data. For this reason, we recommend that you use RAID 1 for MDT storage. If you require more capacity for an MDT than one disk provides, we recommend RAID 1 + 0 or RAID 10.

6.1.2. Object Storage Server (OST)

A quick calculation makes it clear that without further redundancy, RAID 6 is required for large clusters and RAID 5 is not acceptable:

For a 2 PB file system (2,000 disks of 1 TB capacity) assume the mean time to failure (MTTF) of a disk is about 1,000 days. This means that the expected failure rate is $2000/1000 = 2$ disks per day. Repair time at 10% of disk bandwidth is $1000 \text{ GB} / 10 \text{ MB/sec} = 100,000 \text{ sec}$, or about 1 day.

For a RAID 5 stripe that is 10 disks wide, during 1 day of rebuilding, the chance that a second disk in the same array will fail is about $9/1000$ or about 1% per day. After 50 days, you have a 50% chance of a double failure in a RAID 5 array leading to data loss.

Therefore, RAID 6 or another double parity algorithm is needed to provide sufficient redundancy for OST storage.

For better performance, we recommend that you create RAID sets with 4 or 8 data disks plus one or two parity disks. Using larger RAID sets will negatively impact performance compared to having multiple independent RAID sets.

To maximize performance for small I/O request sizes, storage configured as RAID 1+0 can yield much better results but will increase cost or reduce capacity.

6.2. Reliability Best Practices

RAID monitoring software is recommended to quickly detect faulty disks and allow them to be replaced to avoid double failures and data loss. Hot spare disks are recommended so that rebuilds happen without delays.

Backups of the metadata file systems are recommended. For details, see Chapter 18, *Backing Up and Restoring a File System*.

6.3. Performance Tradeoffs

A writeback cache in a RAID storage controller can dramatically increase write performance on many types of RAID arrays if the writes are not done at full stripe width. Unfortunately, unless the RAID array has battery-backed cache (a feature only found in some higher-priced hardware RAID arrays), interrupting the power to the array may result in out-of-sequence or lost writes, and corruption of RAID parity and/or filesystem metadata, resulting in data loss.

Having a read or writeback cache onboard a PCI adapter card installed in an MDS or OSS is *NOT SAFE* in a high-availability (HA) failover configuration, as this will result in inconsistencies between nodes and immediate or eventual filesystem corruption. Such devices should not be used, or should have the onboard cache disabled.

If writeback cache is enabled, a file system check is required after the array loses power. Data may also be lost because of this.

Therefore, we recommend against the use of writeback cache when data integrity is critical. You should carefully consider whether the benefits of using writeback cache outweigh the risks.

6.4. Formatting Options for Idiskfs RAID Devices

When formatting an idiskfs file system on a RAID device, it can be beneficial to ensure that I/O requests are aligned with the underlying RAID geometry. This ensures that Lustre RPCs do not generate unnecessary disk operations which may reduce performance dramatically. Use the `--mkfsoptions` parameter to specify additional parameters when formatting the OST or MDT.

For RAID 5, RAID 6, or RAID 1+0 storage, specifying the following option to the `--mkfsoptions` parameter option improves the layout of the file system metadata, ensuring that no single disk contains all of the allocation bitmaps:

```
-E stride = chunk_blocks
```

The `chunk_blocks` variable is in units of 4096-byte blocks and represents the amount of contiguous data written to a single disk before moving to the next disk. This is alternately referred to as the RAID stripe size. This is applicable to both MDT and OST file systems.

For more information on how to override the defaults while formatting MDT or OST file systems, see Section 5.3, “Setting ldiskfs File System Formatting Options”.

6.4.1. Computing file system parameters for mkfs

For best results, use RAID 5 with 5 or 9 disks or RAID 6 with 6 or 10 disks, each on a different controller. The stripe width is the optimal minimum I/O size. Ideally, the RAID configuration should allow 1 MB Lustre RPCs to fit evenly on a single RAID stripe without an expensive read-modify-write cycle. Use this formula to determine the *stripe_width*, where *number_of_data_disks* does *not* include the RAID parity disks (1 for RAID 5 and 2 for RAID 6):

$$\text{stripe_width_blocks} = \text{chunk_blocks} * \text{number_of_data_disks} = 1 \text{ MB}$$

If the RAID configuration does not allow *chunk_blocks* to fit evenly into 1 MB, select *stripe_width_blocks*, such that is close to 1 MB, but not larger.

The *stripe_width_blocks* value must equal *chunk_blocks* * *number_of_data_disks*. Specifying the *stripe_width_blocks* parameter is only relevant for RAID 5 or RAID 6, and is not needed for RAID 1 plus 0.

Run `--reformat` on the file system device (`/dev/sdc`), specifying the RAID geometry to the underlying ldiskfs file system, where:

```
--mkfsoptions "other_options -E stride=chunk_blocks, stripe_width=stripe_width_blocks"
```

A RAID 6 configuration with 6 disks has 4 data and 2 parity disks. The *chunk_blocks* \leq 1024KB/4 = 256KB.

Because the number of data disks is equal to the power of 2, the stripe width is equal to 1 MB.

```
--mkfsoptions "other_options -E stride=chunk_blocks, stripe_width=stripe_width_blocks"
```

6.4.2. Choosing Parameters for an External Journal

If you have configured a RAID array and use it directly as an OST, it contains both data and metadata. For better performance, we recommend putting the OST journal on a separate device, by creating a small RAID 1 array and using it as an external journal for the OST.

In a typical Lustre file system, the default OST journal size is up to 1GB, and the default MDT journal size is up to 4GB, in order to handle a high transaction rate without blocking on journal flushes. Additionally, a copy of the journal is kept in RAM. Therefore, make sure you have enough RAM on the servers to hold copies of all journals.

The file system journal options are specified to `mkfs.lustre` using the `--mkfsoptions` parameter. For example:

```
--mkfsoptions "other_options -j -J device=/dev/mdJ"
```

To create an external journal, perform these steps for each OST on the OSS:

1. Create a 400 MB (or larger) journal partition (RAID 1 is recommended).

In this example, `/dev/sdb` is a RAID 1 device.

2. Create a journal device on the partition. Run:

```
oss# mke2fs -b 4096 -O journal_dev /dev/sdb journal_size
```

The value of *journal_size* is specified in units of 4096-byte blocks. For example, 262144 for a 1 GB journal size.

3. Create the OST.

In this example, */dev/sdc* is the RAID 6 device to be used as the OST, run:

```
[oss#] mkfs.lustre --ost ... \  
--mkfsoptions="-J device=/dev/sdb1" /dev/sdc
```

4. Mount the OST as usual.

6.5. Connecting a SAN to a Lustre File System

Depending on your cluster size and workload, you may want to connect a SAN to a Lustre file system. Before making this connection, consider the following:

- In many SAN file systems, clients allocate and lock blocks or inodes individually as they are updated. The design of the Lustre file system avoids the high contention that some of these blocks and inodes may have.
- The Lustre file system is highly scalable and can have a very large number of clients. SAN switches do not scale to a large number of nodes, and the cost per port of a SAN is generally higher than other networking.
- File systems that allow direct-to-SAN access from the clients have a security risk because clients can potentially read any data on the SAN disks, and misbehaving clients can corrupt the file system for many reasons like improper file system, network, or other kernel software, bad cabling, bad memory, and so on. The risk increases with increase in the number of clients directly accessing the storage.

Chapter 7. Setting Up Network Interface Bonding

This chapter describes how to use multiple network interfaces in parallel to increase bandwidth and/or redundancy. Topics include:

- Section 7.1, “Network Interface Bonding Overview”
- Section 7.2, “Requirements”
- Section 7.3, “Bonding Module Parameters”
- Section 7.4, “Setting Up Bonding”
- Section 7.5, “Configuring a Lustre File System with Bonding”
- Section 7.6, “Bonding References”

Note

Using network interface bonding is optional.

7.1. Network Interface Bonding Overview

Bonding, also known as link aggregation, trunking and port trunking, is a method of aggregating multiple physical network links into a single logical link for increased bandwidth.

Several different types of bonding are available in the Linux distribution. All these types are referred to as 'modes', and use the bonding kernel module.

Modes 0 to 3 allow load balancing and fault tolerance by using multiple interfaces. Mode 4 aggregates a group of interfaces into a single virtual interface where all members of the group share the same speed and duplex settings. This mode is described under IEEE spec 802.3ad, and it is referred to as either 'mode 4' or '802.3ad.'

7.2. Requirements

The most basic requirement for successful bonding is that both endpoints of the connection must be capable of bonding. In a normal case, the non-server endpoint is a switch. (Two systems connected via crossover cables can also use bonding.) Any switch used must explicitly handle 802.3ad Dynamic Link Aggregation.

The kernel must also be configured with bonding. All supported Lustre kernels have bonding functionality. The network driver for the interfaces to be bonded must have the ethtool functionality to determine slave speed and duplex settings. All recent network drivers implement it.

To verify that your interface works with ethtool, run:

```
# which ethtool
/sbin/ethtool

# ethtool eth0
```

```
Settings for eth0:
  Supported ports: [ TP MII ]
  Supported link modes:   10baseT/Half 10baseT/Full
                        100baseT/Half 100baseT/Full
  Supports auto-negotiation: Yes
  Advertised link modes:  10baseT/Half 10baseT/Full
                        100baseT/Half 100baseT/Full
  Advertised auto-negotiation: Yes
  Speed: 100Mb/s
  Duplex: Full
  Port: MII
  PHYAD: 1
  Transceiver: internal
  Auto-negotiation: on
  Supports Wake-on: pumbg
  Wake-on: d
  Current message level: 0x00000001 (1)
  Link detected: yes
```

```
# ethtool eth1
```

```
Settings for eth1:
  Supported ports: [ TP MII ]
  Supported link modes:   10baseT/Half 10baseT/Full
                        100baseT/Half 100baseT/Full
  Supports auto-negotiation: Yes
  Advertised link modes:  10baseT/Half 10baseT/Full
                        100baseT/Half 100baseT/Full
  Advertised auto-negotiation: Yes
  Speed: 100Mb/s
  Duplex: Full
  Port: MII
  PHYAD: 32
  Transceiver: internal
  Auto-negotiation: on
  Supports Wake-on: pumbg
  Wake-on: d
  Current message level: 0x00000007 (7)
  Link detected: yes
  To quickly check whether your kernel supports bonding, run:
  # grep ifenslave /sbin/ifup
  # which ifenslave
  /sbin/ifenslave
```

7.3. Bonding Module Parameters

Bonding module parameters control various aspects of bonding.

Outgoing traffic is mapped across the slave interfaces according to the transmit hash policy. We recommend that you set the `xmit_hash_policy` option to the `layer3+4` option for bonding. This policy uses upper layer protocol information if available to generate the hash. This allows traffic to a particular network peer to span multiple slaves, although a single connection does not span multiple slaves.

```
$ xmit_hash_policy=layer3+4
```

The `miimon` option enables users to monitor the link status. (The parameter is a time interval in milliseconds.) It makes an interface failure transparent to avoid serious network degradation during link failures. A reasonable default setting is 100 milliseconds; run:

```
$ miimon=100
```

For a busy network, increase the timeout.

7.4. Setting Up Bonding

To set up bonding:

1. Create a virtual 'bond' interface by creating a configuration file:

```
# vi /etc/sysconfig/network-scripts/ifcfg-bond0
```

2. Append the following lines to the file.

```
DEVICE=bond0
IPADDR=192.168.10.79 # Use the free IP Address of your network
NETWORK=192.168.10.0
NETMASK=255.255.255.0
USERCTL=no
BOOTPROTO=none
ONBOOT=yes
```

3. Attach one or more slave interfaces to the bond interface. Modify the `eth0` and `eth1` configuration files (using a VI text editor).

- a. Use the VI text editor to open the `eth0` configuration file.

```
# vi /etc/sysconfig/network-scripts/ifcfg-eth0
```

- b. Modify/append the `eth0` file as follows:

```
DEVICE=eth0
USERCTL=no
ONBOOT=yes
MASTER=bond0
SLAVE=yes
BOOTPROTO=none
```

- c. Use the VI text editor to open the `eth1` configuration file.

```
# vi /etc/sysconfig/network-scripts/ifcfg-eth1
```

- d. Modify/append the `eth1` file as follows:

```
DEVICE=eth1
USERCTL=no
ONBOOT=yes
MASTER=bond0
SLAVE=yes
BOOTPROTO=none
```

4. Set up the bond interface and its options in `/etc/modprobe.d/bond.conf`. Start the slave interfaces by your normal network method.

```
# vi /etc/modprobe.d/bond.conf
```

- a. Append the following lines to the file.

```
alias bond0 bonding
options bond0 mode=balance-alb miimon=100
```

- b. Load the bonding module.

```
# modprobe bonding
# ifconfig bond0 up
# ifenslave bond0 eth0 eth1
```

5. Start/restart the slave interfaces (using your normal network method).

Note

You must modprobe the bonding module for each bonded interface. If you wish to create bond0 and bond1, two entries in bond.conf file are required.

The examples below are from systems running Red Hat Enterprise Linux. For setup use: /etc/sysconfig/networking-scripts/ifcfg-* The website referenced below includes detailed instructions for other configuration methods, instructions to use DHCP with bonding, and other setup details. We strongly recommend you use this website.

<http://www.linuxfoundation.org/networking/bonding> [<https://wiki.linuxfoundation.org/networking/bonding>]

6. Check /proc/net/bonding to determine status on bonding. There should be a file there for each bond interface.

```
# cat /proc/net/bonding/bond0
Ethernet Channel Bonding Driver: v3.0.3 (March 23, 2006)
```

```
Bonding Mode: load balancing (round-robin)
MII Status: up
MII Polling Interval (ms): 0
Up Delay (ms): 0
Down Delay (ms): 0
```

```
Slave Interface: eth0
MII Status: up
Link Failure Count: 0
Permanent HW addr: 4c:00:10:ac:61:e0
```

```
Slave Interface: eth1
MII Status: up
Link Failure Count: 0
Permanent HW addr: 00:14:2a:7c:40:1d
```

7. Use ethtool or ifconfig to check the interface state. ifconfig lists the first bonded interface as 'bond0.'

```
ifconfig
bond0      Link encap:Ethernet  HWaddr 4C:00:10:AC:61:E0
           inet addr:192.168.10.79  Bcast:192.168.10.255  \      Mask:255.255.255.0
```

```
inet6 addr: fe80::4e00:10ff:feac:61e0/64 Scope:Link
UP BROADCAST RUNNING MASTER MULTICAST MTU:1500 Metric:1
RX packets:3091 errors:0 dropped:0 overruns:0 frame:0
TX packets:880 errors:0 dropped:0 overruns:0 carrier:0
collisions:0 txqueuelen:0
RX bytes:314203 (306.8 KiB) TX bytes:129834 (126.7 KiB)

eth0      Link encap:Ethernet HWaddr 4C:00:10:AC:61:E0
inet6 addr: fe80::4e00:10ff:feac:61e0/64 Scope:Link
UP BROADCAST RUNNING SLAVE MULTICAST MTU:1500 Metric:1
RX packets:1581 errors:0 dropped:0 overruns:0 frame:0
TX packets:448 errors:0 dropped:0 overruns:0 carrier:0
collisions:0 txqueuelen:1000
RX bytes:162084 (158.2 KiB) TX bytes:67245 (65.6 KiB)
Interrupt:193 Base address:0x8c00

eth1      Link encap:Ethernet HWaddr 4C:00:10:AC:61:E0
inet6 addr: fe80::4e00:10ff:feac:61e0/64 Scope:Link
UP BROADCAST RUNNING SLAVE MULTICAST MTU:1500 Metric:1
RX packets:1513 errors:0 dropped:0 overruns:0 frame:0
TX packets:444 errors:0 dropped:0 overruns:0 carrier:0
collisions:0 txqueuelen:1000
RX bytes:152299 (148.7 KiB) TX bytes:64517 (63.0 KiB)
Interrupt:185 Base address:0x6000
```

7.4.1. Examples

This is an example showing `bond.conf` entries for bonding Ethernet interfaces `eth1` and `eth2` to `bond0`:

```
# cat /etc/modprobe.d/bond.conf
alias eth0 8139too
alias eth1 via-rhine
alias bond0 bonding
options bond0 mode=balance-alb miimon=100

# cat /etc/sysconfig/network-scripts/ifcfg-bond0
DEVICE=bond0
BOOTPROTO=none
NETMASK=255.255.255.0
IPADDR=192.168.10.79 # (Assign here the IP of the bonded interface.)
ONBOOT=yes
USERCTL=no

ifcfg-ethx
# cat /etc/sysconfig/network-scripts/ifcfg-eth0
TYPE=Ethernet
DEVICE=eth0
HWADDR=4c:00:10:ac:61:e0
BOOTPROTO=none
ONBOOT=yes
USERCTL=no
IPV6INIT=no
PEERDNS=yes
```

```
MASTER=bond0
SLAVE=yes
```

In the following example, the bond0 interface is the master (MASTER) while eth0 and eth1 are slaves (SLAVE).

Note

All slaves of bond0 have the same MAC address (Hwaddr) - bond0. All modes, except TLB and ALB, have this MAC address. TLB and ALB require a unique MAC address for each slave.

```
$ /sbin/ifconfig
```

```
bond0Link encap:EthernetHwaddr 00:C0:F0:1F:37:B4
inet addr:XXX.XXX.XXX.YYY Bcast:XXX.XXX.XXX.255 Mask:255.255.252.0
UP BROADCAST RUNNING MASTER MULTICAST MTU:1500 Metric:1
RX packets:7224794 errors:0 dropped:0 overruns:0 frame:0
TX packets:3286647 errors:1 dropped:0 overruns:1 carrier:0
collisions:0 txqueuelen:0
```

```
eth0Link encap:EthernetHwaddr 00:C0:F0:1F:37:B4
inet addr:XXX.XXX.XXX.YYY Bcast:XXX.XXX.XXX.255 Mask:255.255.252.0
UP BROADCAST RUNNING SLAVE MULTICAST MTU:1500 Metric:1
RX packets:3573025 errors:0 dropped:0 overruns:0 frame:0
TX packets:1643167 errors:1 dropped:0 overruns:1 carrier:0
collisions:0 txqueuelen:100
Interrupt:10 Base address:0x1080
```

```
eth1Link encap:EthernetHwaddr 00:C0:F0:1F:37:B4
inet addr:XXX.XXX.XXX.YYY Bcast:XXX.XXX.XXX.255 Mask:255.255.252.0
UP BROADCAST RUNNING SLAVE MULTICAST MTU:1500 Metric:1
RX packets:3651769 errors:0 dropped:0 overruns:0 frame:0
TX packets:1643480 errors:0 dropped:0 overruns:0 carrier:0
collisions:0 txqueuelen:100
Interrupt:9 Base address:0x1400
```

7.5. Configuring a Lustre File System with Bonding

The Lustre software uses the IP address of the bonded interfaces and requires no special configuration. The bonded interface is treated as a regular TCP/IP interface. If needed, specify bond0 using the Lustre networks parameter in /etc/modprobe.

```
options lnet networks=tcp(bond0)
```

7.6. Bonding References

We recommend the following bonding references:

- In the Linux kernel source tree, see `documentation/networking/bonding.txt`
- <http://linux-ip.net/html/ether-bonding.html> [<http://linux-ip.net/html/ether-bonding.html>].

- Linux Foundation bonding website: <https://www.linuxfoundation.org/networking/bonding> [<https://www.linuxfoundation.org/networking/bonding>]. This is the most extensive reference and we highly recommend it. This website includes explanations of more complicated setups, including the use of DHCP with bonding.

Chapter 8. Installing the Lustre Software

This chapter describes how to install the Lustre software from RPM packages. It includes:

- Section 8.1, “Preparing to Install the Lustre Software”
- Section 8.2, “Lustre Software Installation Procedure”

For hardware and system requirements and hardware configuration information, see Chapter 5, *Determining Hardware Configuration Requirements and Formatting Options*.

8.1. Preparing to Install the Lustre Software

You can install the Lustre software from downloaded packages (RPMs) or directly from the source code. This chapter describes how to install the Lustre RPM packages. Instructions to install from source code are beyond the scope of this document, and can be found elsewhere online.

The Lustre RPM packages are tested on current versions of Linux enterprise distributions at the time they are created. See the release notes for each version for specific details.

8.1.1. Software Requirements

To install the Lustre software from RPMs, the following are required:

- **Lustre server packages** . The required packages for Lustre 2.9 EL7 servers are listed in the table below, where *ver* refers to the Lustre release and kernel version (e.g., 2.9.0-1.el7) and *arch* refers to the processor architecture (e.g., x86_64). These packages are available in the Lustre Releases [<https://wiki.whamcloud.com/display/PUB/Lustre+Releases>] repository, and may differ depending on your distro and version.

Table 8.1. Packages Installed on Lustre Servers

Package Name	Description
<code>kernel-ver_lustre.arch</code>	Linux kernel with Lustre software patches (often referred to as "patched kernel")
<code>lustre-ver.arch</code>	Lustre software command line tools
<code>kmod-lustre-ver.arch</code>	Lustre-patched kernel modules
<code>kmod-lustre-osd-ldiskfs-ver.arch</code>	Lustre back-end file system tools for ldiskfs-based servers.
<code>lustre-osd-ldiskfs-mount-ver.arch</code>	Helper library for <code>mount.lustre</code> and <code>mkfs.lustre</code> for ldiskfs-based servers.
<code>kmod-lustre-osd-zfs-ver.arch</code>	Lustre back-end file system tools for ZFS. This is an alternative to <code>lustre-osd-ldiskfs</code> (<code>kmod-spl</code> and <code>kmod-zfs</code> available separately).
<code>lustre-osd-zfs-mount-ver.arch</code>	Helper library for <code>mount.lustre</code> and <code>mkfs.lustre</code> for ZFS-based servers (<code>zfs</code> utilities available separately).

Package Name	Description
e2fsprogs	Utilities to maintain Lustre ldiskfs back-end file system(s)
lustre-tests-ver_lustre.arch	Scripts and programs used for running regression tests for Lustre, but likely only of interest to Lustre developers or testers.

- **Lustre client packages** . The required packages for Lustre 2.9 EL7 clients are listed in the table below, where *ver* refers to the Linux distribution (e.g., 3.6.18-348.1.1.el5). These packages are available in the Lustre Releases [<https://wiki.whamcloud.com/display/PUB/Lustre+Releases>] repository.

Table 8.2. Packages Installed on Lustre Clients

Package Name	Description
kmod-lustre-client-ver.arch	Patchless kernel modules for client
lustre-client-ver.arch	Client command line tools
lustre-client-dkms-ver.arch	Alternate client RPM to kmod-lustre-client with Dynamic Kernel Module Support (DKMS) installation. This avoids the need to install a new RPM for each kernel update, but requires a full build environment on the client.

Note

The version of the kernel running on a Lustre client must be the same as the version of the `kmod-lustre-client-ver` package being installed, unless the DKMS package is installed. If the kernel running on the client is not compatible, a kernel that is compatible must be installed on the client before the Lustre file system software is used.

- **Lustre LNet network driver (LND)** . The Lustre LNDs provided with the Lustre software are listed in the table below. For more information about Lustre LNet, see Chapter 2, *Understanding Lustre Networking (LNet)*.

Table 8.3. Network Types Supported by Lustre LNDs

Supported Network Types	Notes
TCP	Any network carrying TCP traffic, including GigE, 10GigE, and IPoIB
InfiniBand network	OpenFabrics OFED (o2ib)
gni	Gemini (Cray)

Note

The InfiniBand and TCP Lustre LNDs are routinely tested during release cycles. The other LNDs are maintained by their respective owners

- **High availability software** . If needed, install third party high-availability software. For more information, see Section 11.2, “Preparing a Lustre File System for Failover”.

- **Optional packages.** Optional packages provided in the Lustre Releases [<https://wiki.whamcloud.com/display/PUB/Lustre+Releases>] repository may include the following (depending on the operating system and platform):
 - `kernel-debuginfo`, `kernel-debuginfo-common`, `lustre-debuginfo`, `lustre-osd-ldiskfs-debuginfo`- Versions of required packages with debugging symbols and other debugging options enabled for use in troubleshooting.
 - `kernel-devel`, - Portions of the kernel tree needed to compile third party modules, such as network drivers.
 - `kernel-firmware`- Standard Red Hat Enterprise Linux distribution that has been recompiled to work with the Lustre kernel.
 - `kernel-headers`- Header files installed under `/usr/include` and used when compiling user-space, kernel-related code.
 - `lustre-source`- Lustre software source code.
 - (*Recommended*) `perf`, `perf-debuginfo`, `python-perf`, `python-perf-debuginfo`- Linux performance analysis tools that have been compiled to match the Lustre kernel version.

8.1.2. Environmental Requirements

Before installing the Lustre software, make sure the following environmental requirements are met.

- (*Required*) **Use the same user IDs (UID) and group IDs (GID) on all clients.** If use of supplemental groups is required, see Section 41.1, “User/Group Upcall” for information about supplementary user and group cache upcall (`identity_upcall`).
- (*Recommended*) **Provide remote shell access to clients.** It is recommended that all cluster nodes have remote shell client access to facilitate the use of Lustre configuration and monitoring scripts. Parallel Distributed SHell (`pdsh`) is preferable, although Secure SHell (SSH) is acceptable.
- (*Recommended*) **Ensure client clocks are synchronized.** The Lustre file system uses client clocks for timestamps. If clocks are out of sync between clients, files will appear with different time stamps when accessed by different clients. Drifting clocks can also cause problems by, for example, making it difficult to debug multi-node issues or correlate logs, which depend on timestamps. We recommend that you use Network Time Protocol (NTP) to keep client and server clocks in sync with each other. For more information about NTP, see: <https://www.ntp.org> [<https://www.ntp.org/>].
- (*Recommended*) **Make sure security extensions** (such as the Novell AppArmor^{*} security system) and **network packet filtering tools** (such as `iptables`) do not interfere with the Lustre software.

8.2. Lustre Software Installation Procedure

Caution

Before installing the Lustre software, back up ALL data. The Lustre software contains kernel modifications that interact with storage devices and may introduce security issues and data loss if not installed, configured, or administered properly.

To install the Lustre software from RPMs, complete the steps below.

1. Verify that all Lustre installation requirements have been met.

- For hardware requirements, see Chapter 5, *Determining Hardware Configuration Requirements and Formatting Options*.
 - For software and environmental requirements, see the section Section 8.1, “Preparing to Install the Lustre Software” above.
2. Download the `e2fsprogs` RPMs for your platform from the Lustre Releases [<https://wiki.whamcloud.com/display/PUB/Lustre+Releases>] repository.
 3. Download the Lustre server RPMs for your platform from the Lustre Releases [<https://wiki.whamcloud.com/display/PUB/Lustre+Releases>] repository. See Table 8.1, “Packages Installed on Lustre Servers” for a list of required packages.
 4. Install the Lustre server and `e2fsprogs` packages on all Lustre servers (MGS, MDSs, and OSSs).
 - a. Log onto a Lustre server as the `root` user
 - b. Use the `yum` command to install the packages:

```
# yum --nogpgcheck install pkg1.rpm pkg2.rpm ...
```
 - c. Verify the packages are installed correctly:

```
rpm -qa | egrep "lustre|wc" | sort
```
 - d. Reboot the server.
 - e. Repeat these steps on each Lustre server.
 5. Download the Lustre client RPMs for your platform from the Lustre Releases [<https://wiki.whamcloud.com/display/PUB/Lustre+Releases>] repository. See Table 8.2, “Packages Installed on Lustre Clients” for a list of required packages.
 6. Install the Lustre client packages on all Lustre clients.

Note

The version of the kernel running on a Lustre client must be the same as the version of the `lustre-client-modules-ver` package being installed. If not, a compatible kernel must be installed on the client before the Lustre client packages are installed.

- a. Log onto a Lustre client as the `root` user.
- b. Use the `yum` command to install the packages:

```
# yum --nogpgcheck install pkg1.rpm pkg2.rpm ...
```
- c. Verify the packages were installed correctly:

```
# rpm -qa | egrep "lustre|kernel" | sort
```
- d. Reboot the client.

e. Repeat these steps on each Lustre client.

To configure LNet, go to Chapter 9, *Configuring Lustre Networking (LNet)*. If default settings will be used for LNet, go to Chapter 10, *Configuring a Lustre File System*.

Chapter 9. Configuring Lustre Networking (LNet)

This chapter describes how to configure Lustre Networking (LNet). It includes the following sections:

- Section 9.1, “Configuring LNet via `lnetctl`”
- Section 9.2, “ Overview of LNet Module Parameters”
- Section 9.3, “Setting the LNet Module networks Parameter”
- Section 9.4, “Setting the LNet Module ip2nets Parameter”
- Section 9.5, “Setting the LNet Module routes Parameter”
- Section 9.6, “Testing the LNet Configuration”
- Section 9.7, “Configuring the Router Checker”
- Section 9.8, “Best Practices for LNet Options”

Note

Configuring LNet is optional.

LNet will use the first TCP/IP interface it discovers on a system (`eth0`) if it's loaded using the `lctl network up`. If this network configuration is sufficient, you do not need to configure LNet. LNet configuration is required if you are using Infiniband or multiple Ethernet interfaces.

Introduced in Lustre 2.7

The `lnetctl` utility can be used to initialize LNet without bringing up any network interfaces. Network interfaces can be added after configuring LNet via `lnetctl`. `lnetctl` can also be used to manage an operational LNet. However, if it wasn't initialized by `lnetctl` then `lnetctl lnet configure` must be invoked before `lnetctl` can be used to manage LNet.

Introduced in Lustre 2.7

DLC also introduces a C-API to enable configuring LNet programatically. See Chapter 45, *LNet Configuration C-API*

Introduced in Lustre 2.7

9.1. Configuring LNet via `lnetctl`

The `lnetctl` utility can be used to initialize and configure the LNet kernel module after it has been loaded via `modprobe`. In general the `lnetctl` format is as follows:

```
lnetctl cmd subcmd [options]
```

The following configuration items are managed by the tool:

- Configuring/unconfiguring LNet

- Adding/removing/showing Networks
- Adding/removing/showing Routes
- Enabling/Disabling routing
- Configuring Router Buffer Pools

9.1.1. Configuring LNet

After LNet has been loaded via `modprobe`, `lnetctl` utility can be used to configure LNet without bringing up networks which are specified in the module parameters. It can also be used to configure network interfaces specified in the module parameters by providing the `--all` option.

```
lnetctl lnet configure [--all]
# --all: load NI configuration from module parameters
```

The `lnetctl` utility can also be used to unconfigure LNet.

```
lnetctl lnet unconfigure
```

9.1.2. Displaying Global Settings

The active LNet global settings can be displayed using the `lnetctl` command shown below:

```
lnetctl global show
```

For example:

```
# lnetctl global show
  global:
  numa_range: 0
  max_intf: 200
  discovery: 1
  drop_asym_route: 0
```

9.1.3. Adding, Deleting and Showing Networks

Networks can be added, deleted, or shown after the LNet kernel module is loaded.

The `lnetctl net add` command is used to add networks:

```
lnetctl net add: add a network
  --net: net name (ex tcp0)
  --if: physical interface (ex eth0)
  --peer_timeout: time to wait before declaring a peer dead
  --peer_credits: defines the max number of inflight messages
  --peer_buffer_credits: the number of buffer credits per peer
  --credits: Network Interface credits
  --cpts: CPU Partitions configured net uses
  --help: display this help text
```

Example:

```
lnetctl net add --net tcp2 --if eth0
```



```
--peer_timeout 180 --peer_credits 8
```

Introduced in Lustre 2.10

Note

With the addition of Software based Multi-Rail in Lustre 2.10, the following should be noted:

- `--net`: no longer needs to be unique since multiple interfaces can be added to the same network.
- `--if`: The same interface per network can be added only once, however, more than one interface can now be specified (separated by a comma) for a node. For example: `eth0,eth1,eth2`.

For examples on adding multiple interfaces via `lnetctl net add` and/or YAML, please see Section 16.2, “Configuring Multi-Rail”

Networks can be deleted with the `lnetctl net del` command:

```
net del: delete a network
        --net: net name (ex tcp0)
        --if: physical inerface (e.g. eth0)
```

Example:

```
lnetctl net del --net tcp2
```

Introduced in Lustre 2.10

Note

In a Software Multi-Rail configuration, specifying only the `--net` argument will delete the entire network and all interfaces under it. The new `--if` switch should also be used in conjunction with `--net` to specify deletion of a specific interface.

All or a subset of the configured networks can be shown with the `lnetctl net show` command. The output can be non-verbose or verbose.

```
net show: show networks
        --net: net name (ex tcp0) to filter on
        --verbose: display detailed output per network
```

Examples:

```
lnetctl net show
lnetctl net show --verbose
lnetctl net show --net tcp2 --verbose
```

Below are examples of non-detailed and detailed network configuration show.

```
# non-detailed show
> lnetctl net show --net tcp2
net:
  - nid: 192.168.205.130@tcp2
    status: up
    interfaces:
      0: eth3
```

```
# detailed show
> lnetctl net show --net tcp2 --verbose
net:
  - nid: 192.168.205.130@tcp2
    status: up
    interfaces:
      0: eth3
    tunables:
      peer_timeout: 180
      peer_credits: 8
      peer_buffer_credits: 0
      credits: 256
```

Introduced in Lustre 2.10

9.1.4. Manual Adding, Deleting and Showing Peers

The `lnetctl peer add` command is used to manually add a remote peer to a software multi-rail configuration. For the dynamic peer discovery capability introduced in Lustre Release 2.11.0, please see Section 9.1.5, “Dynamic Peer Discovery”.

When configuring peers, use the `--prim_nid` option to specify the key or primary nid of the peer node. Then follow that with the `--nid` option to specify a set of comma separated NIDs.

```
peer add: add a peer
  --prim_nid: primary NID of the peer
  --nid: comma separated list of peer nids (e.g. 10.1.1.2@tcp0)
  --non_mr: if specified this interface is created as a non multirail
  capable peer. Only one NID can be specified in this case.
```

For example:

```
lnetctl peer add --prim_nid 10.10.10.2@tcp --nid 10.10.3.3@tcp1,10.4.4.4@tcp2
```

The `--prim-nid` (primary nid for the peer node) can go unspecified. In this case, the first listed NID in the `--nid` option becomes the primary nid of the peer. For example:

```
lnetctl peer_add --nid 10.10.10.2@tcp,10.10.3.3@tcp1,10.4.4.5@tcp2
```

YAML can also be used to configure peers:

```
peer:
  - primary nid: <key or primary nid>
  Multi-Rail: True
  peer ni:
    - nid: <nid 1>
    - nid: <nid 2>
    - nid: <nid n>
```

As with all other commands, the result of the `lnetctl peer show` command can be used to gather information to aid in configuring or deleting a peer:

```
lnetctl peer show -v
```

Example output from the `lnetctl peer show` command:

```
peer:
  - primary nid: 192.168.122.218@tcp
    Multi-Rail: True
  peer ni:
    - nid: 192.168.122.218@tcp
      state: NA
      max_ni_tx_credits: 8
      available_tx_credits: 8
      available_rtr_credits: 8
      min_rtr_credits: -1
      tx_q_num_of_buf: 0
      send_count: 6819
      recv_count: 6264
      drop_count: 0
      refcount: 1
    - nid: 192.168.122.78@tcp
      state: NA
      max_ni_tx_credits: 8
      available_tx_credits: 8
      available_rtr_credits: 8
      min_rtr_credits: -1
      tx_q_num_of_buf: 0
      send_count: 7061
      recv_count: 6273
      drop_count: 0
      refcount: 1
    - nid: 192.168.122.96@tcp
      state: NA
      max_ni_tx_credits: 8
      available_tx_credits: 8
      available_rtr_credits: 8
      min_rtr_credits: -1
      tx_q_num_of_buf: 0
      send_count: 6939
      recv_count: 6286
      drop_count: 0
      refcount: 1
```

Use the following `lnetctl` command to delete a peer:

```
peer del: delete a peer
          --prim_nid: Primary NID of the peer
          --nid: comma separated list of peer nids (e.g. 10.1.1.2@tcp0)
```

`prim_nid` should always be specified. The `prim_nid` identifies the peer. If the `prim_nid` is the only one specified, then the entire peer is deleted.

Example of deleting a single nid of a peer (10.10.10.3@tcp):

```
lnetctl peer del --prim_nid 10.10.10.2@tcp --nid 10.10.10.3@tcp
```

Example of deleting the entire peer:

```
lnetctl peer del --prim_nid 10.10.10.2@tcp
```

Introduced in Lustre 2.11

9.1.5. Dynamic Peer Discovery

9.1.5.1. Overview

Dynamic Discovery (DD) is a feature that allows nodes to dynamically discover a peer's interfaces without having to explicitly configure them. This is very useful for Multi-Rail (MR) configurations. In large clusters, there could be hundreds of nodes and having to configure MR peers on each node becomes error prone. Dynamic Discovery is enabled by default and uses a new protocol based on LNet pings to discover the interfaces of the remote peers on first message.

9.1.5.2. Protocol

When LNet on a node is requested to send a message to a peer it first attempts to ping the peer. The reply to the ping contains the peer's NIDs as well as a feature bit outlining what the peer supports. Dynamic Discovery adds a Multi-Rail feature bit. If the peer is Multi-Rail capable, it sets the MR bit in the ping reply. When the node receives the reply it checks the MR bit, and if it is set it then pushes its own list of NIDs to the peer using a new PUT message, referred to as a "push ping". After this brief protocol, both the peer and the node will have each other's list of interfaces. The MR algorithm can then proceed to use the list of interfaces of the corresponding peer.

If the peer is not MR capable, it will not set the MR feature bit in the ping reply. The node will understand that the peer is not MR capable and will only use the interface provided by upper layers for sending messages.

9.1.5.3. Dynamic Discovery and User-space Configuration

It is possible to configure the peer manually while Dynamic Discovery is running. Manual peer configuration always takes precedence over Dynamic Discovery. If there is a discrepancy between the manual configuration and the dynamically discovered information, a warning is printed.

9.1.5.4. Configuration

Dynamic Discovery is very light on the configuration side. It can only be turned on or turned off. To turn the feature on or off, the following command is used:

```
lnetctl set discovery [0 | 1]
```

To check the current discovery setting, the `lnetctl global show` command can be used as shown in Section 9.1.2, "Displaying Global Settings".

9.1.5.5. Initiating Dynamic Discovery on Demand

It is possible to initiate the Dynamic Discovery protocol on demand without having to wait for a message to be sent to the peer. This can be done with the following command:

```
lnetctl discover <peer_nid> [<peer_nid> ...]
```

9.1.6. Adding, Deleting and Showing routes

A set of routes can be added to identify how LNet messages are to be routed.

```
lnetctl route add: add a route
  --net: net name (ex tcp0) LNet message is destined to.
        The can not be a local network.
  --gateway: gateway node nid (ex 10.1.1.2@tcp) to route
            all LNet messaged destined for the identified
            network
  --hop: number of hops to final destination
        (1 <= hops <= 255) (optional)
  --priority: priority of route (0 - highest prio) (optional)
```

Example:

```
lnetctl route add --net tcp2 --gateway 192.168.205.130@tcp1 --hop 2 --prio 1
```

Routes can be deleted via the following lnetctl command.

```
lnetctl route del: delete a route
  --net: net name (ex tcp0)
  --gateway: gateway nid (ex 10.1.1.2@tcp)
```

Example:

```
lnetctl route del --net tcp2 --gateway 192.168.205.130@tcp1
```

Configured routes can be shown via the following lnetctl command.

```
lnetctl route show: show routes
  --net: net name (ex tcp0) to filter on
  --gateway: gateway nid (ex 10.1.1.2@tcp) to filter on
  --hop: number of hops to final destination
        (1 <= hops <= 255) to filter on (-1 default)
  --priority: priority of route (0 - highest prio)
            to filter on (0 default)
  --verbose: display detailed output per route
```

Examples:

```
# non-detailed show
lnetctl route show
```

```
# detailed show
lnetctl route show --verbose
```

When showing routes the `--verbose` option outputs more detailed information. All show and error output are in YAML format. Below are examples of both non-detailed and detailed route show output.

```
#Non-detailed output
> lnetctl route show
route:
  - net: tcp2
    gateway: 192.168.205.130@tcp1
```

```
#detailed output
```

```
> lnetctl route show --verbose
route:
  - net: tcp2
    gateway: 192.168.205.130@tcp1
    hop: 2
    priority: 1
    state: down
```

9.1.7. Enabling and Disabling Routing

When an LNet node is configured as a router it will route LNet messages not destined to itself. This feature can be enabled or disabled as follows.

```
lnetctl set routing [0 | 1]
# 0 - disable routing feature
# 1 - enable routing feature
```

9.1.8. Showing routing information

When routing is enabled on a node, the tiny, small and large routing buffers are allocated. See Section 34.3, “Tuning LNet Parameters” for more details on router buffers. This information can be shown as follows:

```
lnetctl routing show: show routing information
```

Example:

```
lnetctl routing show
```

An example of the show output:

```
> lnetctl routing show
routing:
  - cpt[0]:
    tiny:
      npages: 0
      nbuffers: 2048
      credits: 2048
      mincredits: 2048
    small:
      npages: 1
      nbuffers: 16384
      credits: 16384
      mincredits: 16384
    large:
      npages: 256
      nbuffers: 1024
      credits: 1024
      mincredits: 1024
  - enable: 1
```

9.1.9. Configuring Routing Buffers

The routing buffers values configured specify the number of buffers in each of the tiny, small and large groups.

It is often desirable to configure the tiny, small and large routing buffers to some values other than the default. These values are global values, when set they are used by all configured CPU partitions. If routing is enabled then the values set take effect immediately. If a larger number of buffers is specified, then buffers are allocated to satisfy the configuration change. If fewer buffers are configured then the excess buffers are freed as they become unused. If routing is not set the values are not changed. The buffer values are reset to default if routing is turned off and on.

The `lnetctl 'set'` command can be used to set these buffer values. A `VALUE` greater than 0 will set the number of buffers accordingly. A `VALUE` of 0 will reset the number of buffers to system defaults.

```
set tiny_buffers:
    set tiny routing buffers
        VALUE must be greater than or equal to 0

set small_buffers: set small routing buffers
    VALUE must be greater than or equal to 0

set large_buffers: set large routing buffers
    VALUE must be greater than or equal to 0
```

Usage examples:

```
> lnetctl set tiny_buffers 4096
> lnetctl set small_buffers 8192
> lnetctl set large_buffers 2048
```

The buffers can be set back to the default values as follows:

```
> lnetctl set tiny_buffers 0
> lnetctl set small_buffers 0
> lnetctl set large_buffers 0
```

Introduced in Lustre 2.13

9.1.10. Asymmetrical Routes

9.1.10.1. Overview

An asymmetrical route is when a message from a remote peer is coming through a router that is not known by this node to reach the remote peer.

Asymmetrical routes can be an issue when debugging network, and allowing them also opens the door to attacks where hostile clients inject data to the servers.

So it is possible to activate a check in LNet, that will detect any asymmetrical route message and drop it.

9.1.10.2. Configuration

In order to switch asymmetric route detection on or off, the following command is used:

```
lnetctl set drop_asym_route [0 | 1]
```

This command works on a per-node basis. This means each node in a Lustre cluster can decide whether it accepts asymmetrical route messages.

To check the current `drop_asym_route` setting, the `lnetctl global show` command can be used as shown in Section 9.1.2, “Displaying Global Settings”.

By default, asymmetric route detection is off.

9.1.11. Importing YAML Configuration File

Configuration can be described in YAML format and can be fed into the `lnetctl` utility. The `lnetctl` utility parses the YAML file and performs the specified operation on all entities described there in. If no operation is defined in the command as shown below, the default operation is 'add'. The YAML syntax is described in a later section.

```
lnetctl import FILE.yaml
lnetctl import < FILE.yaml
```

The 'lnetctl import' command provides three optional parameters to define the operation to be performed on the configuration items described in the YAML file.

```
# if no options are given to the command the "add" command is assumed
# by default.
lnetctl import --add FILE.yaml
lnetctl import --add < FILE.yaml

# to delete all items described in the YAML file
lnetctl import --del FILE.yaml
lnetctl import --del < FILE.yaml

# to show all items described in the YAML file
lnetctl import --show FILE.yaml
lnetctl import --show < FILE.yaml
```

9.1.12. Exporting Configuration in YAML format

`lnetctl` utility provides the 'export' command to dump current LNet configuration in YAML format

```
lnetctl export FILE.yaml
lnetctl export > FILE.yaml
```

9.1.13. Showing LNet Traffic Statistics

`lnetctl` utility can dump the LNet traffic statistics as follows

```
lnetctl stats show
```

9.1.14. YAML Syntax

The `lnetctl` utility can take in a YAML file describing the configuration items that need to be operated on and perform one of the following operations: add, delete or show on the items described there in.

Net, routing and route YAML blocks are all defined as a YAML sequence, as shown in the following sections. The stats YAML block is a YAML object. Each sequence item can take a `seq_no` field. This `seq_no` field is returned in the error block. This allows the caller to associate the error with the item that

caused the error. The `lnetctl` utility does a best effort at configuring items defined in the YAML file. It does not stop processing the file at the first error.

Below is the YAML syntax describing the various configuration elements which can be operated on via DLC. Not all YAML elements are required for all operations (add/delete/show). The system ignores elements which are not pertinent to the requested operation.

9.1.14.1. Network Configuration

```
net:
  - net: <network. Ex: tcp or o2ib>
    interfaces:
      0: <physical interface>
    detail: <This is only applicable for show command. 1 - output detailed info.
    tunables:
      peer_timeout: <Integer. Timeout before consider a peer dead>
      peer_credits: <Integer. Transmit credits for a peer>
      peer_buffer_credits: <Integer. Credits available for receiving messages>
      credits: <Integer. Network Interface credits>
    SMP: <An array of integers of the form: "[x,y,...]", where each
    integer represents the CPT to associate the network interface
    with> seq_no: <integer. Optional. User generated, and is
    passed back in the YAML error block>
```

Both `seq_no` and `detail` fields do not appear in the show output.

9.1.14.2. Enable Routing and Adjust Router Buffer Configuration

```
routing:
  - tiny: <Integer. Tiny buffers>
    small: <Integer. Small buffers>
    large: <Integer. Large buffers>
    enable: <0 - disable routing. 1 - enable routing>
    seq_no: <Integer. Optional. User generated, and is passed back in the YAML
```

The `seq_no` field does not appear in the show output

9.1.14.3. Show Statistics

```
statistics:
  seq_no: <Integer. Optional. User generated, and is passed back in the YAML er
```

The `seq_no` field does not appear in the show output

9.1.14.4. Route Configuration

```
route:
  - net: <network. Ex: tcp or o2ib>
    gateway: <nid of the gateway in the form <ip>@<net>: Ex: 192.168.29.1@tcp>
```

```
hop: <an integer between 1 and 255. Optional>
detail: <This is only applicable for show commands. 1 - output detailed info.
seq_no: <integer. Optional. User generated, and is passed back in the YAML err
```

Both seq_no and detail fields do not appear in the show output.

9.2. Overview of LNet Module Parameters

LNet kernel module (lnet) parameters specify how LNet is to be configured to work with Lustre, including which NICs will be configured to work with Lustre and the routing to be used with Lustre.

Parameters for LNet can be specified in the `/etc/modprobe.d/lustre.conf` file. In some cases the parameters may have been stored in `/etc/modprobe.conf`, but this has been deprecated since before RHEL5 and SLES10, and having a separate `/etc/modprobe.d/lustre.conf` file simplifies administration and distribution of the Lustre networking configuration. This file contains one or more entries with the syntax:

```
options lnet parameter=value
```

To specify the network interfaces that are to be used for Lustre, set either the `networks` parameter or the `ip2nets` parameter (only one of these parameters can be used at a time):

- `networks` - Specifies the networks to be used.
- `ip2nets` - Lists globally-available networks, each with a range of IP addresses. LNet then identifies locally-available networks through address list-matching lookup.

See Section 9.3, “Setting the LNet Module `networks` Parameter” and Section 9.4, “Setting the LNet Module `ip2nets` Parameter” for more details.

To set up routing between networks, use:

- `routes` - Lists networks and the NIDs of routers that forward to them.

See Section 9.5, “Setting the LNet Module `routes` Parameter” for more details.

A `router checker` can be configured to enable Lustre nodes to detect router health status, avoid routers that appear dead, and reuse those that restore service after failures. See Section 9.7, “Configuring the Router Checker” for more details.

For a complete reference to the LNet module parameters, see *Chapter 43, Configuration Files and Module Parameters* *LNet Options*.

Note

We recommend that you use 'dotted-quad' notation for IP addresses rather than host names to make it easier to read debug logs and debug configurations with multiple interfaces.

9.2.1. Using a Lustre Network Identifier (NID) to Identify a Node

A Lustre network identifier (NID) is used to uniquely identify a Lustre network endpoint by node ID and network type. The format of the NID is:

```
network_id@network_type
```

Examples are:

```
10.67.73.200@tcp0  
10.67.75.100@o2ib
```

The first entry above identifies a TCP/IP node, while the second entry identifies an InfiniBand node.

When a mount command is run on a client, the client uses the NID of the MDS to retrieve configuration information. If an MDS has more than one NID, the client should use the appropriate NID for its local network.

To determine the appropriate NID to specify in the mount command, use the `lctl` command. To display MDS NIDs, run on the MDS :

```
lctl list_nids
```

To determine if a client can reach the MDS using a particular NID, run on the client:

```
lctl which_nid MDS_NID
```

9.3. Setting the LNet Module networks Parameter

If a node has more than one network interface, you'll typically want to dedicate a specific interface to Lustre. You can do this by including an entry in the `lustre.conf` file on the node that sets the LNet module `networks` parameter:

```
options lnet networks=comma-separated list of  
networks
```

This example specifies that a Lustre node will use a TCP/IP interface and an InfiniBand interface:

```
options lnet networks=tcp0(eth0),o2ib(ib0)
```

This example specifies that the Lustre node will use the TCP/IP interface `eth1`:

```
options lnet networks=tcp0(eth1)
```

Depending on the network design, it may be necessary to specify explicit interfaces. To explicitly specify that interface `eth2` be used for network `tcp0` and `eth3` be used for `tcp1`, use this entry:

```
options lnet networks=tcp0(eth2),tcp1(eth3)
```

When more than one interface is available during the network setup, Lustre chooses the best route based on the hop count. Once the network connection is established, Lustre expects the network to stay connected. In a Lustre network, connections do not fail over to another interface, even if multiple interfaces are available on the same node.

Note

LNet lines in `lustre.conf` are only used by the local node to determine what to call its interfaces. They are not used for routing decisions.

9.3.1. Multihome Server Example

If a server with multiple IP addresses (multihome server) is connected to a Lustre network, certain configuration settings are required. An example illustrating these settings consists of a network with the following nodes:

- Server `svr1` with three TCP NICs (`eth0`, `eth1`, and `eth2`) and an InfiniBand NIC.
- Server `svr2` with three TCP NICs (`eth0`, `eth1`, and `eth2`) and an InfiniBand NIC. Interface `eth2` will not be used for Lustre networking.
- TCP clients, each with a single TCP interface.
- InfiniBand clients, each with a single InfiniBand interface and a TCP/IP interface for administration.

To set the `networks` option for this example:

- On each server, `svr1` and `svr2`, include the following line in the `lustre.conf` file:

```
options lnet networks=tcp0(eth0),tcp1(eth1),o2ib
```

- For TCP-only clients, the first available non-loopback IP interface is used for `tcp0`. Thus, TCP clients with only one interface do not need to have options defined in the `lustre.conf` file.
- On the InfiniBand clients, include the following line in the `lustre.conf` file:

```
options lnet networks=o2ib
```

Note

By default, Lustre ignores the loopback (`lo0`) interface. Lustre does not ignore IP addresses aliased to the loopback. If you alias IP addresses to the loopback interface, you must specify all Lustre networks using the LNet `networks` parameter.

Note

If the server has multiple interfaces on the same subnet, the Linux kernel will send all traffic using the first configured interface. This is a limitation of Linux, not Lustre. In this case, network interface bonding should be used. For more information about network interface bonding, see Chapter 7, *Setting Up Network Interface Bonding*.

9.4. Setting the LNet Module `ip2nets` Parameter

The `ip2nets` option is typically used when a single, universal `lustre.conf` file is run on all servers and clients. Each node identifies the locally available networks based on the listed IP address patterns that match the node's local IP addresses.

Note that the IP address patterns listed in the `ip2nets` option are *only* used to identify the networks that an individual node should instantiate. They are *not* used by LNet for any other communications purpose.

For the example below, the nodes in the network have these IP addresses:

- Server `svr1`: `eth0` IP address `192.168.0.2`, IP over InfiniBand (`o2ib`) address `132.6.1.2`.
- Server `svr2`: `eth0` IP address `192.168.0.4`, IP over InfiniBand (`o2ib`) address `132.6.1.4`.

- TCP clients have IP addresses 192.168.0.5-255.
- Infiniband clients have IP over Infiniband (o2ib) addresses 132.6.[2-3].2, .4, .6, .8.

The following entry is placed in the `lustre.conf` file on each server and client:

```
options lnet 'ip2nets="tcp0(eth0) 192.168.0.[2,4]; \  
tcp0 192.168.0.*; o2ib0 132.6.[1-3].[2-8/2]"'
```

Each entry in `ip2nets` is referred to as a 'rule'.

The order of LNet entries is important when configuring servers. If a server node can be reached using more than one network, the first network specified in `lustre.conf` will be used.

Because `svr1` and `svr2` match the first rule, LNet uses `eth0` for `tcp0` on those machines. (Although `svr1` and `svr2` also match the second rule, the first matching rule for a particular network is used).

The `[2-8/2]` format indicates a range of 2-8 stepped by 2; that is 2,4,6,8. Thus, the clients at 132.6.3.5 will not find a matching `o2ib` network.

Introduced in Lustre 2.10

Note

Multi-rail deprecates the kernel parsing of `ip2nets`. `ip2nets` patterns are matched in user space and translated into Network interfaces to be added into the system.

The first interface that matches the IP pattern will be used when adding a network interface.

If an interface is explicitly specified as well as a pattern, the interface matched using the IP pattern will be sanitized against the explicitly-defined interface.

For example, `tcp(eth0) 192.168.*.3` and there exists in the system `eth0 == 192.158.19.3` and `eth1 == 192.168.3.3`, then the configuration will fail, because the pattern contradicts the interface specified.

A clear warning will be displayed if inconsistent configuration is encountered.

You could use the following command to configure `ip2nets`:

```
lnetctl import < ip2nets.yaml
```

For example:

```
ip2nets:  
- net-spec: tcp1  
  interfaces:  
    0: eth0  
    1: eth1  
  ip-range:  
    0: 192.168.*.19  
    1: 192.168.100.105  
- net-spec: tcp2  
  interfaces:  
    0: eth2  
  ip-range:
```

```
0: 192.168.*.*
```

9.5. Setting the LNet Module routes Parameter

The LNet module routes parameter is used to identify routers in a Lustre configuration. These parameters are set in `modprobe.conf` on each Lustre node.

Routes are typically set to connect to segregated subnetworks or to cross connect two different types of networks such as tcp and o2ib

The LNet routes parameter specifies a colon-separated list of router definitions. Each route is defined as a network number, followed by a list of routers:

```
routes=net_type router_NID(s)
```

This example specifies bi-directional routing in which TCP clients can reach Lustre resources on the IB networks and IB servers can access the TCP networks:

```
options lnet 'ip2nets="tcp0 192.168.0.*; \  
o2ib0(ib0) 132.6.1.[1-128]" ' 'routes="tcp0 132.6.1.[1-8]@o2ib0; \  
o2ib0 192.16.8.0.[1-8]@tcp0" '
```

All LNet routers that bridge two networks are equivalent. They are not configured as primary or secondary, and the load is balanced across all available routers.

The number of LNet routers is not limited. Enough routers should be used to handle the required file serving bandwidth plus a 25 percent margin for headroom.

9.5.1. Routing Example

On the clients, place the following entry in the `lustre.conf` file

```
lnet networks="tcp" routes="o2ib0 192.168.0.[1-8]@tcp0"
```

On the router nodes, use:

```
lnet networks="tcp o2ib" forwarding=enabled
```

On the MDS, use the reverse as shown below:

```
lnet networks="o2ib0" routes="tcp0 132.6.1.[1-8]@o2ib0"
```

To start the routers, run:

```
modprobe lnet  
lctl network configure
```

9.6. Testing the LNet Configuration

After configuring Lustre Networking, it is highly recommended that you test your LNet configuration using the LNet Self-Test provided with the Lustre software. For more information about using LNet Self-Test, see Chapter 32, *Testing Lustre Network Performance (LNet Self-Test)*.

9.7. Configuring the Router Checker

In a Lustre configuration in which different types of networks, such as a TCP/IP network and an Infiniband network, are connected by routers, a router checker can be run on the clients and servers in the routed configuration to monitor the status of the routers. In a multi-hop routing configuration, router checkers can be configured on routers to monitor the health of their next-hop routers.

A router checker is configured by setting LNet parameters in `lustre.conf` by including an entry in this form:

```
options lnet
    router_checker_parameter=value
```

The router checker parameters are:

- `live_router_check_interval` - Specifies a time interval in seconds after which the router checker will ping the live routers. The default value is 0, meaning no checking is done. To set the value to 60, enter:

```
options lnet live_router_check_interval=60
```

- `dead_router_check_interval` - Specifies a time interval in seconds after which the router checker will check for dead routers. The default value is 0, meaning no checking is done. To set the value to 60, enter:

```
options lnet dead_router_check_interval=60
```

- `auto_down` - Enables/disables (1/0) the automatic marking of router state as up or down. The default value is 1. To disable router marking, enter:

```
options lnet auto_down=0
```

- `router_ping_timeout` - Specifies a timeout for the router checker when it checks live or dead routers. The router checker sends a ping message to each dead or live router once every `dead_router_check_interval` or `live_router_check_interval` respectively. The default value is 50. To set the value to 60, enter:

```
options lnet router_ping_timeout=60
```

Note

The `router_ping_timeout` is consistent with the default LND timeouts. You may have to increase it on very large clusters if the LND timeout is also increased. For larger clusters, we suggest increasing the check interval.

- `check_routers_before_use` - Specifies that routers are to be checked before use. Set to off by default. If this parameter is set to on, the `dead_router_check_interval` parameter must be given a positive integer value.

```
options lnet check_routers_before_use=on
```

The router checker obtains the following information from each router:

- Time the router was disabled
- Elapsed disable time

If the router checker does not get a reply message from the router within `router_ping_timeout` seconds, it considers the router to be down.

If a router is marked 'up' and responds to a ping, the timeout is reset.

If 100 packets have been sent successfully through a router, the `sent-packets` counter for that router will have a value of 100.

9.8. Best Practices for LNet Options

For the `networks`, `ip2nets`, and `routes` options, follow these best practices to avoid configuration errors.

9.8.1. Escaping commas with quotes

Depending on the Linux distribution, commas may need to be escaped using single or double quotes. In the extreme case, the `options` entry would look like this:

```
options
    lnet 'networks="tcp0,elan0" '
        'routes="tcp [2,10]@elan0" '
```

Added quotes may confuse some distributions. Messages such as the following may indicate an issue related to added quotes:

```
lnet: Unknown parameter 'networks'
```

A 'Refusing connection - no matching NID' message generally points to an error in the LNet module configuration.

9.8.2. Including comments

Place the semicolon terminating a comment immediately after the comment. LNet silently ignores everything between the # character at the beginning of the comment and the next semicolon.

In this *incorrect* example, LNet silently ignores `pt11 192.168.0.[92,96]`, resulting in these nodes not being properly initialized. No error message is generated.

```
options lnet ip2nets="pt10 192.168.0.[89,93]; # comment
        with semicolon BEFORE comment \ pt11 192.168.0.[92,96];
```

This *correct* example shows the required syntax:

```
options lnet ip2nets="pt10 192.168.0.[89,93] \
# comment with semicolon AFTER comment; \
pt11 192.168.0.[92,96] # comment
```

Do not add an excessive number of comments. The Linux kernel limits the length of character strings used in module options (usually to 1KB, but this may differ between vendor kernels). If you exceed this limit, errors result and the specified configuration may not be processed correctly.

Chapter 10. Configuring a Lustre File System

This chapter shows how to configure a simple Lustre file system comprised of a combined MGS/MDT, an OST and a client. It includes:

- Section 10.1, “Configuring a Simple Lustre File System”
- Section 10.2, “Additional Configuration Options”

10.1. Configuring a Simple Lustre File System

A Lustre file system can be set up in a variety of configurations by using the administrative utilities provided with the Lustre software. The procedure below shows how to configure a simple Lustre file system consisting of a combined MGS/MDS, one OSS with two OSTs, and a client. For an overview of the entire Lustre installation procedure, see Chapter 4, *Installation Overview*.

This configuration procedure assumes you have completed the following:

- **Set up and configured your hardware** . For more information about hardware requirements, see Chapter 5, *Determining Hardware Configuration Requirements and Formatting Options*.
- **Downloaded and installed the Lustre software**. For more information about preparing for and installing the Lustre software, see Chapter 8, *Installing the Lustre Software*.

The following optional steps should also be completed, if needed, before the Lustre software is configured:

- *Set up a hardware or software RAID on block devices to be used as OSTs or MDTs*. For information about setting up RAID, see the documentation for your RAID controller or Chapter 6, *Configuring Storage on a Lustre File System*.
- *Set up network interface bonding on Ethernet interfaces*. For information about setting up network interface bonding, see Chapter 7, *Setting Up Network Interface Bonding*.
- *Set lnet module parameters to specify how Lustre Networking (LNet) is to be configured to work with a Lustre file system and test the LNet configuration*. LNet will, by default, use the first TCP/IP interface it discovers on a system. If this network configuration is sufficient, you do not need to configure LNet. LNet configuration is required if you are using InfiniBand or multiple Ethernet interfaces.

For information about configuring LNet, see Chapter 9, *Configuring Lustre Networking (LNet)*. For information about testing LNet, see Chapter 32, *Testing Lustre Network Performance (LNet Self-Test)*.

- *Run the benchmark script sgpdd-survey to determine baseline performance of your hardware*. Benchmarking your hardware will simplify debugging performance issues that are unrelated to the Lustre software and ensure you are getting the best possible performance with your installation. For information about running sgpdd-survey, see Chapter 33, *Benchmarking Lustre File System Performance (Lustre I/O Kit)*.

Note

The sgpdd-survey script overwrites the device being tested so it must be run before the OSTs are configured.

To configure a simple Lustre file system, complete these steps:

1. Create a combined MGS/MDT file system on a block device. On the MDS node, run:

```
mkfs.lustre --fsname=  
fsname --mgs --mdt --index=0  
/dev/block_device
```

The default file system name (*fsname*) is *lustre*.

Note

If you plan to create multiple file systems, the MGS should be created separately on its own dedicated block device, by running:

```
mkfs.lustre --fsname=  
fsname --mgs  
/dev/block_device
```

See Section 13.8, “Running Multiple Lustre File Systems” for more details.

2. Optionally add in additional MDTs.

```
mkfs.lustre --fsname=  
fsname --mgsnode=  
nid --mdt --index=1  
/dev/block_device
```

Note

Up to 4095 additional MDTs can be added.

3. Mount the combined MGS/MDT file system on the block device. On the MDS node, run:

```
mount -t lustre  
/dev/block_device  
/mount_point
```

Note

If you have created an MGS and an MDT on separate block devices, mount them both.

4. Create the OST. On the OSS node, run:

```
mkfs.lustre --fsname=  
fsname --mgsnode=  
MGS_NID --ost --index=  
OST_index  
/dev/block_device
```

When you create an OST, you are formatting a `ldiskfs` or `ZFS` file system on a block storage device like you would with any local file system.

You can have as many OSTs per OSS as the hardware or drivers allow. For more information about storage and memory requirements for a Lustre file system, see Chapter 5, *Determining Hardware Configuration Requirements and Formatting Options*.

You can only configure one OST per block device. You should create an OST that uses the raw block device and does not use partitioning.

You should specify the OST index number at format time in order to simplify translating the OST number in error messages or file striping to the OSS node and block device later on.

If you are using block devices that are accessible from multiple OSS nodes, ensure that you mount the OSTs from only one OSS node at a time. It is strongly recommended that multiple-mount protection be enabled for such devices to prevent serious data corruption. For more information about multiple-mount protection, see Chapter 24, *Lustre File System Failover and Multiple-Mount Protection*.

Note

The Lustre software currently supports block devices up to 128 TB on Red Hat Enterprise Linux 5 and 6 (up to 8 TB on other distributions). If the device size is only slightly larger than 16 TB, it is recommended that you limit the file system size to 16 TB at format time. We recommend that you not place DOS partitions on top of RAID 5/6 block devices due to negative impacts on performance, but instead format the whole disk for the file system.

5. Mount the OST. On the OSS node where the OST was created, run:

```
mount -t lustre
/dev/block_device
/mount_point
```

Note

To create additional OSTs, repeat Step 4 and Step 5, specifying the next higher OST index number.

6. Mount the Lustre file system on the client. On the client node, run:

```
mount -t lustre
MGS_node:/
fsname
/mount_point
```

Note

To mount the filesystem on additional clients, repeat Step 6.

Note

If you have a problem mounting the file system, check the syslogs on the client and all the servers for errors and also check the network settings. A common issue with newly-installed systems is that `hosts.deny` or firewall rules may prevent connections on port 988.

7. Verify that the file system started and is working correctly. Do this by running `lfs df`, `dd` and `ls` commands on the client node.
8. (Optional) Run benchmarking tools to validate the performance of hardware and software layers in the cluster. Available tools include:
 - `obdfilter-survey`- Characterizes the storage performance of a Lustre file system. For details, see Section 33.3, “Testing OST Performance (`obdfilter-survey`)”.
 - `ost-survey`- Performs I/O against OSTs to detect anomalies between otherwise identical disk subsystems. For details, see Section 33.4, “Testing OST I/O Performance (`ost-survey`)”.

10.1.1. Simple Lustre Configuration Example

To see the steps to complete for a simple Lustre file system configuration, follow this example in which a combined MGS/MDT and two OSTs are created to form a file system called `temp`. Three block devices are used, one for the combined MGS/MDS node and one for each OSS node. Common parameters used in the example are listed below, along with individual node parameters.

Common Parameters	Value	Description
MGS node	10.2.0.1@tcp0	Node for the combined MGS/MDS
file system	temp	Name of the Lustre file system
network type	TCP/IP	Network type used for Lustre file system temp

Node Parameters	Value	Description
MGS/MDS node		
MGS/MDS node	mdt0	MDS in Lustre file system temp
block device	/dev/sdb	Block device for the combined MGS/MDS node
mount point	/mnt/mdt	Mount point for the mdt0 block device (/dev/sdb) on the MGS/MDS node
First OSS node		
OSS node	oss0	First OSS node in Lustre file system temp
OST	ost0	First OST in Lustre file system temp
block device	/dev/sdc	Block device for the first OSS node (oss0)
mount point	/mnt/ost0	Mount point for the ost0 block device (/dev/sdc) on the oss1 node

Node Parameters	Value	Description	
Second OSS node			
	OSS node	oss1	Second OSS node in Lustre file system temp
	OST	ost1	Second OST in Lustre file system temp
	block device	/dev/sdd	Block device for the second OSS node (oss1)
	mount point	/mnt/ost1	Mount point for the ost1 block device (/dev/sdd) on the oss1 node
Client node			
	client node	client1	Client in Lustre file system temp
	mount point	/lustre	Mount point for Lustre file system temp on the client1 node

Note

We recommend that you use 'dotted-quad' notation for IP addresses rather than host names to make it easier to read debug logs and debug configurations with multiple interfaces.

For this example, complete the steps below:

1. Create a combined MGS/MDT file system on the block device. On the MDS node, run:

```
[root@mds /]# mkfs.lustre --fsname=temp --mgs --mdt --index=0 /dev/sdb
```

This command generates this output:

```

Permanent disk data:
Target:          temp-MDT0000
Index:          0
Lustre FS: temp
Mount type:     ldiskfs
Flags:          0x75
(MDT MGS first_time update )
Persistent mount opts: errors=remount-ro,iopen_nopriv,user_xattr
Parameters: mdt.identity_upcall=/usr/sbin/l_getidentity

checking for existing Lustre data: not found
device size = 16MB
2 6 18
formatting backing filesystem ldiskfs on /dev/sdb
target name      temp-MDTffff
4k blocks        0
options          -i 4096 -I 512 -q -O dir_index,uninit_groups -F

```

```
mkfs_cmd = mkfs.ext2 -j -b 4096 -L temp-MDTffff -i 4096 -I 512 -q -O
dir_index,uninit_groups -F /dev/sdb
Writing CONFIGS/mountdata
```

2. Mount the combined MGS/MDT file system on the block device. On the MDS node, run:

```
[root@mds /]# mount -t lustre /dev/sdb /mnt/mdt
```

This command generates this output:

```
Lustre: temp-MDT0000: new disk, initializing
Lustre: 3009:0:(lproc_mds.c:262:lprocfs_wr_identity_upcall()) temp-MDT0000:
group upcall set to /usr/sbin/l_getidentity
Lustre: temp-MDT0000.mdt: set parameter identity_upcall=/usr/sbin/l_getidentity
Lustre: Server temp-MDT0000 on device /dev/sdb has started
```

3. Create and mount ost0.

In this example, the OSTs (ost0 and ost1) are being created on different OSS nodes (oss0 and oss1 respectively).

- a. Create ost0. On oss0 node, run:

```
[root@oss0 /]# mkfs.lustre --fsname=temp --mgsnode=10.2.0.1@tcp0 --ost
--index=0 /dev/sdc
```

The command generates this output:

```
Permanent disk data:
Target:          temp-OST0000
Index:           0
Lustre FS: temp
Mount type:      ldiskfs
Flags:           0x72
(OST first_time update)
Persistent mount opts: errors=remount-ro, extents, mballocc
Parameters: mgsnode=10.2.0.1@tcp

checking for existing Lustre data: not found
device size = 16MB
2 6 18
formatting backing filesystem ldiskfs on /dev/sdc
target name      temp-OST0000
4k blocks        0
options          -I 256 -q -O dir_index,uninit_groups -F
mkfs_cmd = mkfs.ext2 -j -b 4096 -L temp-OST0000 -I 256 -q -O
dir_index,uninit_groups -F /dev/sdc
Writing CONFIGS/mountdata
```

- b. Mount ost0 on the OSS on which it was created. On oss0 node, run:

```
root@oss0 /] mount -t lustre /dev/sdc /mnt/ost0
```

The command generates this output:

```
LDISKFS-fs: file extents enabled
LDISKFS-fs: mballoc enabled
Lustre: temp-OST0000: new disk, initializing
Lustre: Server temp-OST0000 on device /dev/sdb has started
```

Shortly afterwards, this output appears:

```
Lustre: temp-OST0000: received MDS connection from 10.2.0.1@tcp0
Lustre: MDS temp-MDT0000: temp-OST0000_UUID now active, resetting orphans
```

4. Create and mount ost1.

a. Create ost1. On oss1 node, run:

```
[root@oss1 /]# mkfs.lustre --fsname=temp --mgsnode=10.2.0.1@tcp0 \
--ost --index=1 /dev/sdd
```

The command generates this output:

```
Permanent disk data:
Target:          temp-OST0001
Index:           1
Lustre FS: temp
Mount type:      ldiskfs
Flags:           0x72
(OST first_time update)
Persistent mount opts: errors=remount-ro,extents,mballoc
Parameters: mgsnode=10.2.0.1@tcp

checking for existing Lustre data: not found
device size = 16MB
2 6 18
formatting backing filesystem ldiskfs on /dev/sdd
target name      temp-OST0001
4k blocks        0
options          -I 256 -q -O dir_index,uninit_groups -F
mkfs_cmd = mkfs.ext2 -j -b 4096 -L temp-OST0001 -I 256 -q -O
dir_index,uninit_groups -F /dev/sdc
Writing CONFIGS/mountdata
```

b. Mount ost1 on the OSS on which it was created. On oss1 node, run:

```
root@oss1 /] mount -t lustre /dev/sdd /mnt/ost1
```

The command generates this output:

```
LDISKFS-fs: file extents enabled
LDISKFS-fs: mballocc enabled
Lustre: temp-OST0001: new disk, initializing
Lustre: Server temp-OST0001 on device /dev/sdb has started
```

Shortly afterwards, this output appears:

```
Lustre: temp-OST0001: received MDS connection from 10.2.0.1@tcp0
Lustre: MDS temp-MDT0000: temp-OST0001_UUID now active, resetting orphans
```

5. Mount the Lustre file system on the client. On the client node, run:

```
root@client1 [/] mount -t lustre 10.2.0.1@tcp0:/temp /lustre
```

This command generates this output:

```
Lustre: Client temp-client has started
```

6. Verify that the file system started and is working by running the `df`, `dd` and `ls` commands on the client node.

- a. Run the `lfs df -h` command:

```
[root@client1 [/] lfs df -h
```

The `lfs df -h` command lists space usage per OST and the MDT in human-readable format. This command generates output similar to this:

UUID	bytes	Used	Available	Use%	Mounted on
temp-MDT0000_UUID	8.0G	400.0M	7.6G	0%	/lustre[MDT:0]
temp-OST0000_UUID	800.0G	400.0M	799.6G	0%	/lustre[OST:0]
temp-OST0001_UUID	800.0G	400.0M	799.6G	0%	/lustre[OST:1]
filesystem summary:	1.6T	800.0M	1.6T	0%	/lustre

- b. Run the `lfs df -ih` command.

```
[root@client1 [/] lfs df -ih
```

The `lfs df -ih` command lists inode usage per OST and the MDT. This command generates output similar to this:

UUID	Inodes	IUsed	IFree	IUse%	Mounted on
temp-MDT0000_UUID	2.5M	32	2.5M	0%	/lustre[MDT:0]
temp-OST0000_UUID	5.5M	54	5.5M	0%	/lustre[OST:0]
temp-OST0001_UUID	5.5M	54	5.5M	0%	/lustre[OST:1]
filesystem summary:	2.5M	32	2.5M	0%	/lustre

- c. Run the `dd` command:

```
[root@client1 /] cd /lustre
[root@client1 /lustre] dd if=/dev/zero of=/lustre/zero.dat bs=4M count=2
```

The `dd` command verifies write functionality by creating a file containing all zeros (0s). In this command, an 8 MB file is created. This command generates output similar to this:

```
2+0 records in
2+0 records out
8388608 bytes (8.4 MB) copied, 0.159628 seconds, 52.6 MB/s
```

d. Run the `ls` command:

```
[root@client1 /lustre] ls -lsah
```

The `ls -lsah` command lists files and directories in the current working directory. This command generates output similar to this:

```
total 8.0M
4.0K drwxr-xr-x  2 root root 4.0K Oct 16 15:27 .
8.0K drwxr-xr-x 25 root root 4.0K Oct 16 15:27 ..
8.0M -rw-r--r--  1 root root 8.0M Oct 16 15:27 zero.dat
```

Once the Lustre file system is configured, it is ready for use.

10.2. Additional Configuration Options

This section describes how to scale the Lustre file system or make configuration changes using the Lustre configuration utilities.

10.2.1. Scaling the Lustre File System

A Lustre file system can be scaled by adding OSTs or clients. For instructions on creating additional OSTs repeat Step 3 and Step 5 above. For mounting additional clients, repeat Step 6 for each client.

10.2.2. Changing Striping Defaults

The default settings for the file layout stripe pattern are shown in Table 10.1, “Default stripe pattern”.

Table 10.1. Default stripe pattern

File Layout Parameter	Default	Description
<code>stripe_size</code>	1 MB	Amount of data to write to one OST before moving to the next OST.
<code>stripe_count</code>	1	The number of OSTs to use for a single file.
<code>start_ost</code>	-1	The first OST where objects are created for each file. The default -1 allows the MDS to choose the

starting index based on available space and load balancing. *It's strongly recommended not to change the default for this parameter to a value other than -1.*

Use the `lfs setstripe` command described in Chapter 19, *Managing File Layout (Striping) and Free Space* to change the file layout configuration.

10.2.3. Using the Lustre Configuration Utilities

If additional configuration is necessary, several configuration utilities are available:

- `mkfs.lustre`- Use to format a disk for a Lustre service.
- `tunefs.lustre`- Use to modify configuration information on a Lustre target disk.
- `lctl`- Use to directly control Lustre features via an `ioctl` interface, allowing various configuration, maintenance and debugging features to be accessed.
- `mount.lustre`- Use to start a Lustre client or target service.

For examples using these utilities, see the topic Chapter 44, *System Configuration Utilities*

The `lfs` utility is useful for configuring and querying a variety of options related to files. For more information, see Chapter 40, *User Utilities*.

Note

Some sample scripts are included in the directory where the Lustre software is installed. If you have installed the Lustre source code, the scripts are located in the `lustre/tests` sub-directory. These scripts enable quick setup of some simple standard Lustre configurations.

Chapter 11. Configuring Failover in a Lustre File System

This chapter describes how to configure failover in a Lustre file system. It includes:

- Section 11.1, “Setting Up a Failover Environment”
- Section 11.2, “Preparing a Lustre File System for Failover”
- Section 11.3, “Administering Failover in a Lustre File System”

For an overview of failover functionality in a Lustre file system, see Chapter 3, *Understanding Failover in a Lustre File System*.

11.1. Setting Up a Failover Environment

The Lustre software provides failover mechanisms only at the layer of the Lustre file system. No failover functionality is provided for system-level components such as failing hardware or applications, or even for the entire failure of a node, as would typically be provided in a complete failover solution. Failover functionality such as node monitoring, failure detection, and resource fencing must be provided by external HA software, such as PowerMan or the open source Corosync and Pacemaker packages provided by Linux operating system vendors. Corosync provides support for detecting failures, and Pacemaker provides the actions to take once a failure has been detected.

11.1.1. Selecting Power Equipment

Failover in a Lustre file system requires the use of a remote power control (RPC) mechanism, which comes in different configurations. For example, Lustre server nodes may be equipped with IPMI/BMC devices that allow remote power control. In the past, software or even “sneakerware” has been used, but these are not recommended. For recommended devices, refer to the list of supported RPC devices on the website for the PowerMan cluster power management utility:

<https://linux.die.net/man/7/powerman-devices> [<https://linux.die.net/man/7/powerman-devices>]

11.1.2. Selecting Power Management Software

Lustre failover requires RPC and management capability to verify that a failed node is shut down before I/O is directed to the failover node. This avoids double-mounting the two nodes and the risk of unrecoverable data corruption. A variety of power management tools will work. Two packages that have been commonly used with the Lustre software are PowerMan and Linux-HA (aka. STONITH).

The PowerMan cluster power management utility is used to control RPC devices from a central location. PowerMan provides native support for several RPC varieties and Expect-like configuration simplifies the addition of new devices. The latest versions of PowerMan are available at:

<https://github.com/chaos/powerman> [<https://github.com/chaos/powerman>]

STONITH, or “Shoot The Other Node In The Head”, is a set of power management tools provided with the Linux-HA package prior to Red Hat Enterprise Linux 6. Linux-HA has native support for many power control devices, is extensible (uses Expect scripts to automate control), and provides the software to detect and respond to failures. With Red Hat Enterprise Linux 6, Linux-HA is being replaced in the open source

community by the combination of Corosync and Pacemaker. For Red Hat Enterprise Linux subscribers, cluster management using CMAN is available from Red Hat.

11.1.3. Selecting High-Availability (HA) Software

The Lustre file system must be set up with high-availability (HA) software to enable a complete Lustre failover solution. Except for PowerMan, the HA software packages mentioned above provide both power management and cluster management. For information about setting up failover with Pacemaker, see:

- Pacemaker Project website: <https://clusterlabs.org/> [<https://clusterlabs.org/>]
- Article *Using Pacemaker with a Lustre File System* : <https://wiki.whamcloud.com/display/PUB/Using+Pacemaker+with+a+Lustre+File+System> [<https://wiki.whamcloud.com/display/PUB/Using+Pacemaker+with+a+Lustre+File+System>]

11.2. Preparing a Lustre File System for Failover

To prepare a Lustre file system to be configured and managed as an HA system by a third-party HA application, each storage target (MGT, MGS, OST) must be associated with a second node to create a failover pair. This configuration information is then communicated by the MGS to a client when the client mounts the file system.

The per-target configuration is relayed to the MGS at mount time. Some rules related to this are:

- When a target is initially mounted, the MGS reads the configuration information from the target (such as `mgt vs. ost`, `failnode`, `fsname`) to configure the target into a Lustre file system. If the MGS is reading the initial mount configuration, the mounting node becomes that target's "primary" node.
- When a target is subsequently mounted, the MGS reads the current configuration from the target and, as needed, will reconfigure the MGS database target information

When the target is formatted using the `mkfs.lustre` command, the failover service node(s) for the target are designated using the `--servicenode` option. In the example below, an OST with index 0 in the file system `testfs` is formatted with two service nodes designated to serve as a failover pair:

```
mkfs.lustre --reformat --ost --fsname testfs --mgsnode=192.168.10.1@o3ib \  
--index=0 --servicenode=192.168.10.7@o2ib \  
--servicenode=192.168.10.8@o2ib \  
/dev/sdb
```

More than two potential service nodes can be designated for a target. The target can then be mounted on any of the designated service nodes.

When HA is configured on a storage target, the Lustre software enables multi-mount protection (MMP) on that storage target. MMP prevents multiple nodes from simultaneously mounting and thus corrupting the data on the target. For more about MMP, see Chapter 24, *Lustre File System Failover and Multiple-Mount Protection*.

If the MGT has been formatted with multiple service nodes designated, this information must be conveyed to the Lustre client in the mount command used to mount the file system. In the example below, NIDs for two MGSs that have been designated as service nodes for the MGT are specified in the mount command executed on the client:

```
mount -t lustre 10.10.120.1@tcp1:10.10.120.2@tcp1:/testfs /lustre/testfs
```

When a client mounts the file system, the MGS provides configuration information to the client for the MDT(s) and OST(s) in the file system along with the NIDs for all service nodes associated with each target and the service node on which the target is mounted. Later, when the client attempts to access data on a target, it will try the NID for each specified service node until it connects to the target.

11.3. Administering Failover in a Lustre File System

For additional information about administering failover features in a Lustre file system, see:

- Section 13.6, “Specifying Failout/Failover Mode for OSTs”
- Section 13.13, “Specifying NIDs and Failover”
- Section 14.12, “Changing the Address of a Failover Node”
- Section 44.12, “mkfs.lustre”

Part III. Administering Lustre

Part III provides information about tools and procedures to use to administer a Lustre file system. You will find information in this section about:

- Monitoring a Lustre File System
- Lustre Maintenance
- Managing Lustre Networking (LNet)
- Upgrading a Lustre File System
- Backing Up and Restoring a File System
- Managing File Layout (Striping) and Free Space
- Managing the File System and I/O
- Lustre File System Failover and Multiple-Mount Protection
- Configuring and Managing Quotas
- Hierarchical Storage Management (HSM)
- Mapping UIDs and GIDs with Nodemap
- Configuring Shared-Secret Key (SSK) Security
- Managing Security in a Lustre File System
- Lustre ZFS Snapshots

Tip

The starting point for administering a Lustre file system is to monitor all logs and console logs for system health:

- Monitor logs on all servers and all clients.
 - Invest in tools that allow you to condense logs from multiple systems.
 - Use the logging resources provided in the Linux distribution.
-

Table of Contents

12. Monitoring a Lustre File System	94
12.1. Lustre Changelogs	94
12.1.1. Working with Changelogs	95
12.1.2. Changelog Examples	96
12.1.3. Audit with Changelogs	L 2.11 98
12.2. Lustre Jobstats	100
12.2.1. How Jobstats Works	101
12.2.2. Enable/Disable Jobstats	102
12.2.3. Check Job Stats	103
12.2.4. Clear Job Stats	104
12.2.5. Configure Auto-cleanup Interval	104
12.2.6. Identifying Top Jobs	L 2.14 105
12.3. Lustre Monitoring Tool (LMT)	105
12.4. CollectL	105
12.5. Other Monitoring Options	105
13. Lustre Operations	107
13.1. Mounting by Label	107
13.2. Starting Lustre	107
13.3. Mounting a Server	108
13.4. Stopping the Filesystem	108
13.5. Unmounting a Specific Target on a Server	110
13.6. Specifying Failout/Failover Mode for OSTs	110
13.7. Handling Degraded OST RAID Arrays	111
13.8. Running Multiple Lustre File Systems	111
13.9. Creating a sub-directory on a specific MDT	113
13.10. Creating a directory striped across multiple MDTs	L 2.8 114
13.10.1. Directory creation by space/inode usage	L 2.13 114
13.10.2. Filesystem-wide default directory striping	L 2.14 115
13.11. Default Dir Stripe Policy	116
13.12. Setting and Retrieving Lustre Parameters	116
13.12.1. Setting Tunable Parameters with <code>mkfs.lustre</code>	117
13.12.2. Setting Parameters with <code>tunefs.lustre</code>	117
13.12.3. Setting Parameters with <code>lctl</code>	117
13.13. Specifying NIDs and Failover	120
13.14. Erasing a File System	121
13.15. Reclaiming Reserved Disk Space	122
13.16. Replacing an Existing OST or MDT	122
13.17. Identifying To Which Lustre File an OST Object Belongs	122
14. Lustre Maintenance	124
14.1. Working with Inactive OSTs	124
14.2. Finding Nodes in the Lustre File System	125
14.3. Mounting a Server Without Lustre Service	125
14.4. Regenerating Lustre Configuration Logs	126
14.5. Changing a Server NID	127
14.6. Clearing configuration	L 2.11 128
14.7. Adding a New MDT to a Lustre File System	129
14.8. Adding a New OST to a Lustre File System	129
14.9. Removing and Restoring MDTs and OSTs	130
14.9.1. Removing an MDT from the File System	131
14.9.2. Working with Inactive MDTs	131
14.9.3. Removing an OST from the File System	131

14.9.4. Backing Up OST Configuration Files	133
14.9.5. Restoring OST Configuration Files	134
14.9.6. Returning a Deactivated OST to Service	135
14.10. Aborting Recovery	135
14.11. Determining Which Machine is Serving an OST	135
14.12. Changing the Address of a Failover Node	136
14.13. Separate a combined MGS/MDT	136
14.14. Set an MDT to read-only	L 2.13 137
14.15. Tune Fallocate for ldiskfs	L 2.14 137
15. Managing Lustre Networking (LNet)	139
15.1. Updating the Health Status of a Peer or Router	139
15.2. Starting and Stopping LNet	139
15.2.1. Starting LNet	139
15.2.2. Stopping LNet	140
15.3. Hardware Based Multi-Rail Configurations with LNet	141
15.4. Load Balancing with an InfiniBand* Network	141
15.4.1. Setting Up lustre.conf for Load Balancing	141
15.5. Dynamically Configuring LNet Routes	143
15.5.1. lustre_routes_config	143
15.5.2. lustre_routes_conversion	144
15.5.3. Route Configuration Examples	144
16. LNet Software Multi-Rail	L 2.10 145
16.1. Multi-Rail Overview	145
16.2. Configuring Multi-Rail	145
16.2.1. Configure Multiple Interfaces on the Local Node	145
16.2.2. Deleting Network Interfaces	147
16.2.3. Adding Remote Peers that are Multi-Rail Capable	147
16.2.4. Deleting Remote Peers	148
16.3. Notes on routing with Multi-Rail	149
16.3.1. Multi-Rail Cluster Example	149
16.3.2. Utilizing Router Resiliency	151
16.3.3. Mixed Multi-Rail/Non-Multi-Rail Cluster	151
16.4. Multi-Rail Routing with LNet Health	L 2.13 152
16.4.1. Configuration	152
16.4.2. Router Health	153
16.4.3. Discovery	153
16.4.4. Route Aliveness Criteria	153
16.5. LNet Health	L 2.12 154
16.5.1. Health Value	154
16.5.2. Failure Types and Behavior	154
16.5.3. User Interface	155
16.5.4. Displaying Information	157
16.5.5. Initial Settings Recommendations	159
17. Upgrading a Lustre File System	161
17.1. Release Interoperability and Upgrade Requirements	161
17.2. Upgrading to Lustre Software Release 2.x (Major Release)	161
17.3. Upgrading to Lustre Software Release 2.x.y (Minor Release)	165
18. Backing Up and Restoring a File System	167
18.1. Backing up a File System	167
18.1.1. Lustre_rsync	168
18.2. Backing Up and Restoring an MDT or OST (ldiskfs Device Level)	170
18.3. Backing Up an OST or MDT (Backend File System Level)	171
18.3.1. Backing Up an OST or MDT (Backend File System Level)	L 2.11 171
18.3.2. Backing Up an OST or MDT	172

18.4. Restoring a File-Level Backup	174
18.5. Using LVM Snapshots with the Lustre File System	176
18.5.1. Creating an LVM-based Backup File System	176
18.5.2. Backing up New/Changed Files to the Backup File System	178
18.5.3. Creating Snapshot Volumes	178
18.5.4. Restoring the File System From a Snapshot	178
18.5.5. Deleting Old Snapshots	180
18.5.6. Changing Snapshot Volume Size	180
18.6. Migration Between ZFS and ldiskfs Target Filesystems	L 2.11 180
18.6.1. Migrate from a ZFS to an ldiskfs based filesystem	180
18.6.2. Migrate from an ldiskfs to a ZFS based filesystem	180
19. Managing File Layout (Striping) and Free Space	182
19.1. How Lustre File System Striping Works	182
19.2. Lustre File Layout (Striping) Considerations	182
19.2.1. Choosing a Stripe Size	183
19.3. Setting the File Layout/Striping Configuration (<code>lfs setstripe</code>)	184
19.3.1. Specifying a File Layout (Striping Pattern) for a Single File	185
19.3.2. Setting the Striping Layout for a Directory	186
19.3.3. Setting the Striping Layout for a File System	186
19.3.4. Per File System Stripe Count Limit	186
19.3.5. Creating a File on a Specific OST	187
19.4. Retrieving File Layout/Striping Information (<code>getstripe</code>)	187
19.4.1. Displaying the Current Stripe Size	187
19.4.2. Inspecting the File Tree	188
19.4.3. Locating the MDT for a remote directory	188
19.5. Progressive File Layout(PFL)	L 2.10 188
19.5.1. <code>lfs setstripe</code>	190
19.5.2. <code>lfs migrate</code>	197
19.5.3. <code>lfs getstripe</code>	201
19.5.4. <code>lfs find</code>	205
19.6. Self-Extending Layout (SEL)	L 2.13 206
19.6.1. <code>lfs setstripe</code>	207
19.6.2. <code>lfs getstripe</code>	209
19.6.3. <code>lfs find</code>	216
19.7. Foreign Layout	L 2.13 217
19.7.1. <code>lfs set[dir]stripe</code>	217
19.7.2. <code>lfs get[dir]stripe</code>	218
19.7.3. <code>lfs find</code>	218
19.8. Managing Free Space	219
19.8.1. Checking File System Free Space	219
19.8.2. Stripe Allocation Methods	221
19.8.3. Adjusting the Weighting Between Free Space and Location	222
19.9. Lustre Striping Internals	222
20. Data on MDT (DoM)	L 2.11 224
20.1. Introduction to Data on MDT (DoM)	224
20.2. User Commands	224
20.2.1. <code>lfs setstripe</code> for DoM files	224
20.2.2. Setting a default DoM layout to an existing directory	226
20.2.3. DoM Stripe Size Restrictions	228
20.2.4. <code>lfs getstripe</code> for DoM files	228
20.2.5. <code>lfs find</code> for DoM files	229
20.2.6. The <code>dom_stripesize</code> parameter	230
20.2.7. Disable DoM	231
21. Lazy Size on MDT (LSoM)	L 2.12 232

21.1. Introduction to Lazy Size on MDT (LSoM)	232
21.2. Enable LSoM	232
21.3. User Commands	233
21.3.1. Lfs getsom for LSoM data	233
21.3.2. Syncing LSoM data	233
22. File Level Redundancy (FLR)	L 2.11 235
22.1. Introduction	235
22.2. Operations	235
22.2.1. Creating a Mirrored File or Directory	235
22.2.2. Extending a Mirrored File	240
22.2.3. Splitting a Mirrored File	244
22.2.4. Resynchronizing out-of-sync Mirrored File(s)	249
22.2.5. Verifying Mirrored File(s)	253
22.2.6. Finding Mirrored File(s)	255
22.3. Interoperability	256
23. Managing the File System and I/O	258
23.1. Handling Full OSTs	258
23.1.1. Checking OST Space Usage	258
23.1.2. Disabling creates on a Full OST	259
23.1.3. Migrating Data within a File System	259
23.1.4. Returning an Inactive OST Back Online	259
23.1.5. Migrating Metadata within a Filesystem	259
23.2. Creating and Managing OST Pools	261
23.2.1. Working with OST Pools	262
23.2.2. Tips for Using OST Pools	264
23.3. Adding an OST to a Lustre File System	264
23.4. Performing Direct I/O	265
23.4.1. Making File System Objects Immutable	265
23.5. Other I/O Options	265
23.5.1. Lustre Checksums	265
23.5.2. PtlRPC Client Thread Pool	266
24. Lustre File System Failover and Multiple-Mount Protection	268
24.1. Overview of Multiple-Mount Protection	268
24.2. Working with Multiple-Mount Protection	268
25. Configuring and Managing Quotas	270
25.1. Working with Quotas	270
25.2. Enabling Disk Quotas	270
25.2.1. Quota Verification	272
25.3. Quota Administration	273
25.4. Default Quota	L 2.12 275
25.4.1. Usage	275
25.5. Quota Allocation	277
25.6. Quotas and Version Interoperability	278
25.7. Granted Cache and Quota Limits	278
25.8. Lustre Quota Statistics	279
25.8.1. Interpreting Quota Statistics	280
25.9. Pool Quotas	L 2.14 280
25.9.1. DOM and MDT pools	281
25.9.2. Lfs quota/setquota options to setup quota pools	281
25.9.3. Quota pools interoperability	281
25.9.4. Pool Quotas Hard Limit setup example	281
25.9.5. Pool Quotas Soft Limit setup example	282
26. Hierarchical Storage Management (HSM)	L 2.5 283
26.1. Introduction	283

26.2. Setup	283
26.2.1. Requirements	283
26.2.2. Coordinator	284
26.2.3. Agents	284
26.3. Agents and copytool	284
26.3.1. Archive ID, multiple backends	284
26.3.2. Registered agents	285
26.3.3. Timeout	285
26.4. Requests	285
26.4.1. Commands	286
26.4.2. Automatic restore	286
26.4.3. Request monitoring	286
26.5. File states	286
26.6. Tuning	287
26.6.1. hsm_controlpolicy	287
26.6.2. max_requests	287
26.6.3. policy	287
26.6.4. grace_delay	288
26.7. change logs	288
26.8. Policy engine	288
26.8.1. Robinhood	289
27. Persistent Client Cache (PCC)	L 2.13 290
27.1. Introduction	290
27.2. Design	290
27.2.1. Lustre Read-Write PCC Caching	290
27.2.2. Rule-based Persistent Client Cache	291
27.3. PCC Command Line Tools	291
27.3.1. Add a PCC backend on a client	291
27.3.2. Delete a PCC backend from a client	293
27.3.3. Remove all PCC backends on a client	293
27.3.4. List all PCC backends on a client	293
27.3.5. Attach given files into PCC	294
27.3.6. Attach given files into PCC by FID(s)	294
27.3.7. Detach given files from PCC	294
27.3.8. Detach given files from PCC by FID(s)	295
27.3.9. Display the PCC state for given files	295
27.4. PCC Configuration Example	296
28. Mapping UIDs and GIDs with Nodemap	L 2.9 297
28.1. Setting a Mapping	297
28.1.1. Defining Terms	297
28.1.2. Deciding on NID Ranges	297
28.1.3. Defining a Servers Specific Group	298
28.1.4. Describing and Deploying a Sample Mapping	298
28.1.5. Mapping Project IDs	L 2.15 300
28.2. Removing Nodemaps	300
28.3. Altering Properties	300
28.3.1. Managing the Properties	301
28.3.2. Mixing Properties	302
28.4. Enabling the Feature	303
28.5. default Nodemap	303
28.6. Verifying Settings	304
28.7. Ensuring Consistency	304
29. Configuring Shared-Secret Key (SSK) Security	L 2.9 306
29.1. SSK Security Overview	306

29.1.1. Key features	306
29.2. SSK Security Flavors	306
29.2.1. Secure RPC Rules	307
29.3. SSK Key Files	309
29.3.1. Key File Management	310
29.4. Lustre GSS Keyring	313
29.4.1. Setup	313
29.4.2. Server Setup	313
29.4.3. Debugging GSS Keyring	315
29.4.4. Revoking Keys	316
29.5. Role of Nodemap in SSK	316
29.6. SSK Examples	317
29.6.1. Securing Client to Server Communications	317
29.6.2. Securing MGS Communications	318
29.6.3. Securing Server to Server Communications	319
29.7. Viewing Secure PtRPC Contexts	320
30. Managing Security in a Lustre File System	321
30.1. Using ACLs	321
30.1.1. How ACLs Work	321
30.1.2. Using ACLs with the Lustre Software	321
30.1.3. Examples	322
30.2. Using Root Squash	322
30.3. Isolating Clients to a Sub-directory Tree	323
30.3.1. Identifying Clients	323
30.3.2. Configuring Isolation	323
30.3.3. Making Isolation Permanent	324
30.4. Checking SELinux Policy Enforced by Lustre Clients	L 2.13 324
30.4.1. Determining SELinux Policy Info	324
30.4.2. Enforcing SELinux Policy Check	325
30.4.3. Making SELinux Policy Check Permanent	325
30.4.4. Sending SELinux Status Info from Clients	325
30.5. Encrypting files and directories	L 2.14 326
30.5.1. Client-side encryption access semantics	326
30.5.2. Client-side encryption key hierarchy	328
30.5.3. Client-side encryption modes and usage	328
30.5.4. Client-side encryption threat model	329
30.5.5. Manage encryption on directories	330
30.6. Configuring Kerberos (KRB) Security	332
30.6.1. What Is Kerberos?	333
30.6.2. Security Flavor	333
30.6.3. Kerberos Setup	334
30.6.4. Networking	335
30.6.5. Required packages	336
30.6.6. Build Lustre	336
30.6.7. Running	336
30.6.8. Secure MGS connection	338
31. Lustre ZFS Snapshots	L 2.10 339
31.1. Introduction	339
31.1.1. Requirements	339
31.2. Configuration	339
31.3. Snapshot Operations	341
31.3.1. Creating a Snapshot	341
31.3.2. Delete a Snapshot	341
31.3.3. Mounting a Snapshot	341

31.3.4. Unmounting a Snapshot	342
31.3.5. List Snapshots	343
31.3.6. Modify Snapshot Attributes	343
31.4. Global Write Barriers	343
31.4.1. Impose Barrier	344
31.4.2. Remove Barrier	344
31.4.3. Query Barrier	344
31.4.4. Rescan Barrier	345
31.5. Snapshot Logs	345
31.6. Lustre Configuration Logs	346

Chapter 12. Monitoring a Lustre File System

This chapter provides information on monitoring a Lustre file system and includes the following sections:

- Section 12.1, “Lustre Changelogs”Lustre Changelogs
- Section 12.2, “Lustre Jobstats”Lustre Jobstats
- Section 12.3, “Lustre Monitoring Tool (LMT)”Lustre Monitoring Tool
- Section 12.4, “CollectL”CollectL
- Section 12.5, “Other Monitoring Options”Other Monitoring Options

12.1. Lustre Changelogs

The changelogs feature records events that change the file system namespace or file metadata. Changes such as file creation, deletion, renaming, attribute changes, etc. are recorded with the target and parent file identifiers (FIDs), the name of the target, a timestamp, and user information. These records can be used for a variety of purposes:

- Capture recent changes to feed into an archiving system.
- Use changelog entries to exactly replicate changes in a file system mirror.
- Set up "watch scripts" that take action on certain events or directories.
- Audit activity on Lustre, thanks to user information associated to file/directory changes with timestamps.

Changelogs record types are:

Value	Description
MARK	Internal recordkeeping
CREAT	Regular file creation
MKDIR	Directory creation
HLINK	Hard link
SLINK	Soft link
MKNOD	Other file creation
UNLNK	Regular file removal
RMDIR	Directory removal
RENME	Rename, original
RNMTO	Rename, final
OPEN *	Open
CLOSE	Close
LYOUT	Layout change

Value	Description
TRUNC	Regular file truncated
SATTR	Attribute change
XATTR	Extended attribute change (setxattr)
HSM	HSM specific event
MTIME	MTIME change
CTIME	CTIME change
ATIME *	ATIME change
MIGRT	Migration event
FLRW	File Level Replication: file initially written
RESYNC	File Level Replication: file re-synced
GXATTR *	Extended attribute access (getxattr)
NOPEN *	Denied open

Note

Event types marked with * are not recorded by default. Refer to Section 12.1.2.7, “Setting the Changelogs Mask” for instructions on modifying the Changelogs mask.

FID-to-full-pathname and pathname-to-FID functions are also included to map target and parent FIDs into the file system namespace.

12.1.1. Working with Changelogs

Several commands are available to work with changelogs.

12.1.1.1. `lctl changelog_register`

Because changelog records take up space on the MDT, the system administration must register changelog users. As soon as a changelog user is registered, the Changelogs feature is enabled. The registrants specify which records they are "done with", and the system purges up to the greatest common record.

To register a new changelog user, run:

```
mds# lctl --device fsname-MDTnumber changelog_register
```

Changelog entries are not purged beyond a registered user's set point (see `lfs changelog_clear`).

12.1.1.2. `lfs changelog`

To display the metadata changes on an MDT (the changelog records), run:

```
client# lfs changelog fsname-MDTnumber [startrec [endrec]]
```

It is optional whether to specify the start and end records.

These are sample changelog records:

```
1 02MKDIR 15:15:21.977666834 2018.01.09 0x0 t=[0x200000402:0x1:0x0] j=mkdir.500 ef=0x0
u=500:500 nid=10.128.11.159@tcp p=[0x200000007:0x1:0x0] pics
2 01CREAT 15:15:36.687592024 2018.01.09 0x0 t=[0x200000402:0x2:0x0] j=cp.500 ef=0x0
u=500:500 nid=10.128.11.159@tcp p=[0x200000402:0x1:0x0] chloe.jpg
3 06UNLNK 15:15:41.305116815 2018.01.09 0x1 t=[0x200000402:0x2:0x0] j=rm.500 ef=0x0
u=500:500 nid=10.128.11.159@tcp p=[0x200000402:0x1:0x0] chloe.jpg
4 07RMDIR 15:15:46.468790091 2018.01.09 0x1 t=[0x200000402:0x1:0x0] j=rmdir.500 ef=0x0
u=500:500 nid=10.128.11.159@tcp p=[0x200000007:0x1:0x0] pics
```

12.1.1.3. lfs changelog_clear

To clear old changelog records for a specific user (records that the user no longer needs), run:

```
client# lfs changelog_clear mdt_name userid endrec
```

The `changelog_clear` command indicates that changelog records previous to `endrec` are no longer of interest to a particular user `userid`, potentially allowing the MDT to free up disk space. An `endrec` value of 0 indicates the current last record. To run `changelog_clear`, the changelog user must be registered on the MDT node using `lctl`.

When all changelog users are done with records < X, the records are deleted.

12.1.1.4. lctl changelog_deregister

To deregister (unregister) a changelog user, run:

```
mgs# lctl --device mdt_device changelog_deregister userid
```

`changelog_deregister c11` effectively does a `lfs changelog_clear c11 0` as it deregisters.

12.1.2. Changelog Examples

This section provides examples of different changelog commands.

12.1.2.1. Registering a Changelog User

To register a new changelog user for a device (`lustre-MDT0000`):

```
mgs# lctl --device lustre-MDT0000 changelog_register
lustre-MDT0000: Registered changelog userid 'c11'
```

12.1.2.2. Displaying Changelog Records

To display changelog records for an MDT (e.g. `lustre-MDT0000`):

```
client# lfs changelog lustre-MDT0000
1 02MKDIR 15:15:21.977666834 2018.01.09 0x0 t=[0x200000402:0x1:0x0] ef=0xf \
```



```

u=500:500 nid=10.128.11.159@tcp p=[0x200000007:0x1:0x0] pics
2 01CREAT 15:15:36.687592024 2018.01.09 0x0 t=[0x200000402:0x2:0x0] ef=0xf \
u=500:500 nid=10.128.11.159@tcp p=[0x200000402:0x1:0x0] chloe.jpg
3 06UNLNK 15:15:41.305116815 2018.01.09 0x1 t=[0x200000402:0x2:0x0] ef=0xf \
u=500:500 nid=10.128.11.159@tcp p=[0x200000402:0x1:0x0] chloe.jpg
4 07RMDIR 15:15:46.468790091 2018.01.09 0x1 t=[0x200000402:0x1:0x0] ef=0xf \
u=500:500 nid=10.128.11.159@tcp p=[0x200000007:0x1:0x0] pics

```

Changelog records include this information:

```

rec# operation_type(numerical/text) timestamp datestamp flags
t=target_FID ef=extended_flags u=uid:gid nid=client_NID p=parent_FID target_name

```

Displayed in this format:

```

rec# operation_type(numerical/text) timestamp datestamp flags t=target_FID \
ef=extended_flags u=uid:gid nid=client_NID p=parent_FID target_name

```

For example:

```

2 01CREAT 15:15:36.687592024 2018.01.09 0x0 t=[0x200000402:0x2:0x0] ef=0xf \
u=500:500 nid=10.128.11.159@tcp p=[0x200000402:0x1:0x0] chloe.jpg

```

12.1.2.3. Clearing Changelog Records

To notify a device that a specific user (c11) no longer needs records (up to and including 3):

```
# lfs changelog_clear lustre-MDT0000 c11 3
```

To confirm that the `changelog_clear` operation was successful, run `lfs changelog`; only records after id-3 are listed:

```

# lfs changelog lustre-MDT0000
4 07RMDIR 15:15:46.468790091 2018.01.09 0x1 t=[0x200000402:0x1:0x0] ef=0xf \
u=500:500 nid=10.128.11.159@tcp p=[0x200000007:0x1:0x0] pics

```

12.1.2.4. Deregistering a Changelog User

To deregister a changelog user (c11) for a specific device (lustre-MDT0000):

```

mds# lctl --device lustre-MDT0000 changelog_deregister c11
lustre-MDT0000: Deregistered changelog user 'c11'

```

The deregistration operation clears all changelog records for the specified user (c11).

```

client# lfs changelog lustre-MDT0000
5 00MARK 15:56:39.603643887 2018.01.09 0x0 t=[0x20001:0x0:0x0] ef=0xf \
u=500:500 nid=0@<0:0> p=[0:0x50:0xb] mdd_obd-lustre-MDT0000-0

```

Note

MARK records typically indicate changelog recording status changes.

12.1.2.5. Displaying the Changelog Index and Registered Users

To display the current, maximum changelog index and registered changelog users for a specific device (lustre-MDT0000):

```

mds# lctl get_param mdd.lustre-MDT0000.changelog_users
mdd.lustre-MDT0000.changelog_users=current index: 8
ID      index (idle seconds)
c12    8 (180)

```

12.1.2.6. Displaying the Changelog Mask

To show the current changelog mask on a specific device (lustre-MDT0000):

```

mds# lctl get_param mdd.lustre-MDT0000.changelog_mask

mdd.lustre-MDT0000.changelog_mask=
MARK CREAT MKDIR HLINK SLINK MKNOD UNLNK RMDIR RENME RNMTO CLOSE LYOUT \
TRUNC SATTR XATTR HSM MTIME CTIME MIGRT

```

12.1.2.7. Setting the Changelog Mask

To set the current changelog mask on a specific device (lustre-MDT0000):

```

mds# lctl set_param mdd.lustre-MDT0000.changelog_mask=HLINK
mdd.lustre-MDT0000.changelog_mask=HLINK
$ lfs changelog_clear lustre-MDT0000 c11 0
$ mkdir /mnt/lustre/mydir/foo
$ cp /etc/hosts /mnt/lustre/mydir/foo/file
$ ln /mnt/lustre/mydir/foo/file /mnt/lustre/mydir/myhardlink

```

Only item types that are in the mask show up in the changelog.

```

# lfs changelog lustre-MDT0000
9 03HLINK 16:06:35.291636498 2018.01.09 0x0 t=[0x200000402:0x4:0x0] ef=0xf \
u=500:500 nid=10.128.11.159@tcp p=[0x200000007:0x3:0x0] myhardlink

```

Introduced in Lustre 2.11

12.1.3. Audit with Changelogs

A specific use case for Lustre Changelogs is audit. According to a definition found on Wikipedia [https://en.wikipedia.org/wiki/Information_technology_audit], information technology audits are used to evaluate the organization's ability to protect its information assets and to properly dispense information to authorized parties. Basically, audit consists in controlling that all data accesses made were done according to the access control policy in place. And usually, this is done by analyzing access logs.

Audit can be used as a proof of security in place. But Audit can also be a requirement to comply with regulations.

Lustre Changelogs are a good mechanism for audit, because this is a centralized facility, and it is designed to be transactional. Changelog records contain all information necessary for auditing purposes:

- ability to identify object of action thanks to file identifiers (FIDs) and name of targets
- ability to identify subject of action thanks to UID/GID and NID information
- ability to identify time of action thanks to timestamp

12.1.3.1. Enabling Audit

To have a fully functional Changelogs-based audit facility, some additional Changelog record types must be enabled, to be able to record events such as OPEN, ATIME, GETXATTR and DENIED OPEN. Please note that enabling these record types may have some performance impact. For instance, recording OPEN and GETXATTR events generate writes in the Changelog records for a read operation from a file-system standpoint.

Being able to record events such as OPEN or DENIED OPEN is important from an audit perspective. For instance, if Lustre file system is used to store medical records on a system dedicated to Life Sciences, data privacy is crucial. Administrators may need to know which doctors accessed, or tried to access, a given medical record and when. And conversely, they might need to know which medical records a given doctor accessed.

To enable all changelog entry types, do:

```
mds# lctl set_param mdd.lustre-MDT0000.changelog_mask=ALL
mdd.seb-MDT0000.changelog_mask=ALL
```

Once all required record types have been enabled, just register a Changelogs user and the audit facility is operational.

Note that, however, it is possible to control which Lustre client nodes can trigger the recording of file system access events to the Changelogs, thanks to the `audit_mode` flag on nodemap entries. The reason to disable audit on a per-nodemap basis is to prevent some nodes (e.g. backup, HSM agent nodes) from flooding the audit logs. When `audit_mode` flag is set to 1 on a nodemap entry, a client pertaining to this nodemap will be able to record file system access events to the Changelogs, if Changelogs are otherwise activated. When set to 0, events are not logged into the Changelogs, no matter if Changelogs are activated or not. By default, `audit_mode` flag is set to 1 in newly created nodemap entries. And it is also set to 1 in 'default' nodemap.

To prevent nodes pertaining to a nodemap to generate Changelog entries, do:

```
mgs# lctl nodemap_modify --name nml --property audit_mode --value 0
```

12.1.3.2. Audit examples

12.1.3.2.1. OPEN

An OPEN changelog entry is in the form:

```
7 10OPEN 13:38:51.510728296 2017.07.25 0x242 t=[0x200000401:0x2:0x0] \
ef=0x7 u=500:500 nid=10.128.11.159@tcp m=-w-
```

It includes information about the open mode, in the form `m=rwx`.

OPEN entries are recorded only once per UID/GID, for a given open mode, as long as the file is not closed by this UID/GID. It avoids flooding the Changelogs for instance if there is an MPI job opening the same file thousands of times from different threads. It reduces the ChangeLog load significantly, without significantly affecting the audit information. Similarly, only the last CLOSE per UID/GID is recorded.

12.1.3.2.2. GETXATTR

A GETXATTR changelog entry is in the form:

```
8 23GXATR 09:22:55.886793012 2017.07.27 0x0 t=[0x200000402:0x1:0x0] \
ef=0xf u=500:500 nid=10.128.11.159@tcp x=user.name0
```

It includes information about the name of the extended attribute being accessed, in the form `x=<xattr name>`.

12.1.3.2.3. SETXATTR

A SETXATTR changelog entry is in the form:

```
4 15XATTR 09:41:36.157333594 2018.01.10 0x0 t=[0x200000402:0x1:0x0] \
ef=0xf u=500:500 nid=10.128.11.159@tcp x=user.name0
```

It includes information about the name of the extended attribute being modified, in the form `x=<xattr name>`.

12.1.3.2.4. DENIED OPEN

A DENIED OPEN changelog entry is in the form:

```
4 24NOOPEN 15:45:44.947406626 2017.08.31 0x2 t=[0x200000402:0x1:0x0] \
ef=0xf u=500:500 nid=10.128.11.158@tcp m=-w-
```

It has the same information as a regular OPEN entry. In order to avoid flooding the Changelogs, DENIED OPEN entries are rate limited: no more than one entry per user per file per time interval, this time interval (in seconds) being configurable via `mdd.<mdtname>.changelog_deniednext` (default value is 60 seconds).

```
mds# lctl set_param mdd.lustre-MDT0000.changelog_deniednext=120
mdd.seb-MDT0000.changelog_deniednext=120
mds# lctl get_param mdd.lustre-MDT0000.changelog_deniednext
mdd.seb-MDT0000.changelog_deniednext=120
```

12.2. Lustre Jobstats

The Lustre jobstats feature collects file system operation statistics for user processes running on Lustre clients, and exposes on the server using the unique Job Identifier (JobID) provided by the job scheduler for

each job. Job schedulers known to be able to work with jobstats include: SLURM, SGE, LSF, Loadleveler, PBS and Maui/MOAB.

Since jobstats is implemented in a scheduler-agnostic manner, it is likely that it will be able to work with other schedulers also, and also in environments that do not use a job scheduler, by storing custom format strings in the `jobid_name`.

12.2.1. How Jobstats Works

The Lustre jobstats code on the client extracts the unique JobID from an environment variable within the user process, and sends this JobID to the server with all RPCs. This allows the server to track statistics for operations specific to each application/command running on the client, and can be useful to identify the source high I/O load.

A Lustre setting on the client, `jobid_var`, specifies an environment variable or other client-local source that holds a (relatively) unique the JobID for the running application. Any environment variable can be specified. For example, SLURM sets the `SLURM_JOB_ID` environment variable with the unique JobID for all clients running a particular job launched on one or more nodes, and the `SLURM_JOB_ID` will be inherited by all child processes started below that process.

There are several reserved values for `jobid_var`:

- `disable` - disables sending a JobID from this client
- `procname_uid` - uses the process name and UID, equivalent to setting `jobid_name=%e.%u`
- `nodelocal` - use only the JobID format from `jobid_name`
- `session` - extract the JobID from `jobid_this_session`

Lustre can also be configured to generate a synthetic JobID from the client's process name and numeric UID, by setting `jobid_var=procname_uid`. This will generate a uniform JobID when running the same binary across multiple client nodes, but cannot distinguish whether the binary is part of a single distributed process or multiple independent processes. This can be useful on login nodes where interactive commands are run.

Introduced in Lustre 2.8

In Lustre 2.8 and later it is possible to set `jobid_var=nodelocal` and then also set `jobid_name=name`, which *all* processes on that client node will use. This is useful if only a single job is run on a client at one time, but if multiple jobs are run on a client concurrently, the `session` JobID should be used.

Introduced in Lustre 2.12

In Lustre 2.12 and later, it is possible to specify more complex JobID values for `jobid_name` by using a string that contains format codes that are evaluated for each process, in order to generate a site- or node-specific JobID string.

- `%e` print executable name
- `%g` print group ID number
- `%h` print fully-qualified hostname
- `%H` print short hostname

- `%j` print JobID from the source named by the `jobid_var` parameter
- `%p` print numeric process ID
- `%u` print user ID number

Introduced in Lustre 2.13

In Lustre 2.13 and later, it is possible to set a per-session JobID via the `jobid_this_session` parameter *instead* of getting the JobID from an environment variable. This session ID will be inherited by all processes that are started in this login session, though there can be a different JobID for each login session. This is enabled by setting `jobid_var=session` instead of setting it to an environment variable. The session ID will be substituted for `%j` in `jobid_name`.

The setting of `jobid_var` need not be the same on all clients. For example, one could use `SLURM_JOB_ID` on all clients managed by SLURM, and use `procname_uid` on clients not managed by SLURM, such as interactive login nodes.

It is not possible to have different `jobid_var` settings on a single node, since it is unlikely that multiple job schedulers are active on one client. However, the actual JobID value is local to each process environment and it is possible for multiple jobs with different JobIDs to be active on a single client at one time.

12.2.2. Enable/Disable Jobstats

Jobstats are disabled by default. The current state of jobstats can be verified by checking `lctl get_param jobid_var` on a client:

```
client# lctl get_param jobid_var
jobid_var=disable
```

To enable jobstats on all clients for SLURM:

```
mgs# lctl set_param -P jobid_var=SLURM_JOB_ID
```

The `lctl set_param` command to enable or disable jobstats should be run on the MGS as root. The change is persistent, and will be propagated to the MDS, OSS, and client nodes automatically when it is set on the MGS and for each new client mount.

To temporarily enable jobstats on a client, or to use a different `jobid_var` on a subset of nodes, such as nodes in a remote cluster that use a different job scheduler, or interactive login nodes that do not use a job scheduler at all, run the `lctl set_param` command directly on the client node(s) after the filesystem is mounted. For example, to enable the `procname_uid` synthetic JobID locally on a login node run:

```
client# lctl set_param jobid_var=procname_uid
```

The `lctl set_param` setting is not persistent, and will be reset if the global `jobid_var` is set on the MGS or if the filesystem is unmounted.

The following table shows the environment variables which are set by various job schedulers. Set `jobid_var` to the value for your job scheduler to collect statistics on a per job basis.

Job Scheduler	Environment Variable
Simple Linux Utility for Resource Management (SLURM)	SLURM_JOB_ID
Sun Grid Engine (SGE)	JOB_ID
Load Sharing Facility (LSF)	LSB_JOBID
Loadleveler	LOADL_STEP_ID
Portable Batch Scheduler (PBS)/MAUI	PBS_JOBID
Cray Application Level Placement Scheduler (ALPS)	ALPS_APP_ID

```
mgs# lctl set_param -P jobid_var=disable
```

To track job stats per process name and user ID (for debugging, or if no job scheduler is in use on some nodes such as login nodes), specify `jobid_var` as `procname_uid`:

```
client# lctl set_param jobid_var=procname_uid
```

12.2.3. Check Job Stats

Metadata operation statistics are collected on MDTs. These statistics can be accessed for all file systems and all jobs on the MDT via the `lctl get_param mdt.*.job_stats`. For example, clients running with `jobid_var=procname_uid`:

```
mgs# lctl get_param mdt.*.job_stats
job_stats:
- job_id:          bash.0
  snapshot_time:  1352084992
  open:           { samples:    2, unit: reqs }
  close:          { samples:    2, unit: reqs }
  getattr:        { samples:    3, unit: reqs }
- job_id:          mythbackend.0
  snapshot_time:  1352084996
  open:           { samples:   72, unit: reqs }
  close:          { samples:   73, unit: reqs }
  unlink:         { samples:   22, unit: reqs }
  getattr:        { samples:  778, unit: reqs }
  setattr:        { samples:   22, unit: reqs }
  statfs:         { samples: 19840, unit: reqs }
  sync:           { samples: 33190, unit: reqs }
```

Data operation statistics are collected on OSTs. Data operations statistics can be accessed via `lctl get_param obdfilter.*.job_stats`, for example:

```
oss# lctl get_param obdfilter.*.job_stats
obdfilter.myth-OST0000.job_stats=
job_stats:
- job_id:          mythcommflag.0
  snapshot_time:  1429714922
```

```

    read:    { samples: 974, unit: bytes, min: 4096, max: 1048576, sum: 91530035 }
    write:   { samples:  0, unit: bytes, min:    0, max:    0, sum:    0 }
obdfilter.myth-OST0001.job_stats=
job_stats:
- job_id:           mythbackend.0
  snapshot_time:    1429715270
  read:    { samples:  0, unit: bytes, min:    0, max:    0, sum:    0 }
  write:   { samples:  1, unit: bytes, min: 96899, max:  96899, sum:   96899 }
  punch:   { samples:  1, unit: reqs }
obdfilter.myth-OST0002.job_stats=job_stats:
obdfilter.myth-OST0003.job_stats=job_stats:
obdfilter.myth-OST0004.job_stats=
job_stats:
- job_id:           mythfrontend.500
  snapshot_time:    1429692083
  read:    { samples:  9, unit: bytes, min: 16384, max: 1048576, sum: 4444160 }
  write:   { samples:  0, unit: bytes, min:    0, max:    0, sum:    0 }
- job_id:           mythbackend.500
  snapshot_time:    1429692129
  read:    { samples:  0, unit: bytes, min:    0, max:    0, sum:    0 }
  write:   { samples:  1, unit: bytes, min: 56231, max:  56231, sum:   56231 }
  punch:   { samples:  1, unit: reqs }

```

12.2.4. Clear Job Stats

Accumulated job statistics can be reset by writing proc file `job_stats`.

Clear statistics for all jobs on the local node:

```
oss# lctl set_param obdfilter.*.job_stats=clear
```

Clear statistics only for job 'bash.0' on lustre-MDT0000:

```
mds# lctl set_param mdt.lustre-MDT0000.job_stats=bash.0
```

12.2.5. Configure Auto-cleanup Interval

By default, if a job is inactive for 600 seconds (10 minutes) statistics for this job will be dropped. This expiration value can be changed temporarily via:

```
mds# lctl set_param *.*.job_cleanup_interval={max_age}
```

It can also be changed permanently, for example to 700 seconds via:

```
mgm# lctl set_param -P mdt.testfs-*.job_cleanup_interval=700
```

The `job_cleanup_interval` can be set as 0 to disable the auto-cleanup. Note that if auto-cleanup of Jobstats is disabled, then all statistics will be kept in memory forever, which may eventually consume all memory on the servers. In this case, any monitoring tool should explicitly clear individual job statistics as they are processed, as shown above.

Introduced in Lustre 2.14

12.2.6. Identifying Top Jobs

Since Lustre 2.15 the `lljobstat` utility can be used to monitor and identify the top JobIDs generating load on a particular server. This allows the administrator to quickly see which applications/users/clients (depending on how the JobID is configured) are generating the most filesystem RPCs and take appropriate action if needed.

```
mds# lljobstat -c 10
---
    timestamp: 1665984678
    top_jobs:
    - ls.500:          {ops: 64, ga: 64}
    - touch.500:      {ops: 6, op: 1, cl: 1, mn: 1, ga: 1, sa: 2}
    - bash.0:         {ops: 3, ga: 3}
    ...
```

It is possible to specify the number of top jobs to monitor as well as the refresh interval, among other options.

12.3. Lustre Monitoring Tool (LMT)

The Lustre Monitoring Tool (LMT) is a Python-based, distributed system that provides a `top`-like display of activity on server-side nodes (MDS, OSS and portals routers) on one or more Lustre file systems. It does not provide support for monitoring clients. For more information on LMT, including the setup procedure, see:

<https://github.com/chaos/lmt/wiki> [<https://github.com/chaos/lmt/wiki>]

12.4. CollectL

CollectL is another tool that can be used to monitor a Lustre file system. You can run CollectL on a Lustre system that has any combination of MDSs, OSTs and clients. The collected data can be written to a file for continuous logging and played back at a later time. It can also be converted to a format suitable for plotting.

For more information about CollectL, see:

<http://collectl.sourceforge.net> [<http://collectl.sourceforge.net>]

Lustre-specific documentation is also available. See:

<http://collectl.sourceforge.net/Tutorial-Lustre.html> [<http://collectl.sourceforge.net/Tutorial-Lustre.html>]

12.5. Other Monitoring Options

A variety of standard tools are available publicly including the following:

- `lltop` - Lustre load monitor with batch scheduler integration. <https://github.com/jhammond/lltop>

- `tacc_stats` - A job-oriented system monitor, analyzation, and visualization tool that probes Lustre interfaces and collects statistics. https://github.com/jhammond/tacc_stats
- `xltop` - A continuous Lustre monitor with batch scheduler integration. <https://github.com/jhammond/xltop>

Another option is to script a simple monitoring solution that looks at various reports from `ipconfig`, as well as the `procs` files generated by the Lustre software.

Chapter 13. Lustre Operations

Once you have the Lustre file system up and running, you can use the procedures in this section to perform these basic Lustre administration tasks.

13.1. Mounting by Label

The file system name is limited to 8 characters. We have encoded the file system and target information in the disk label, so you can mount by label. This allows system administrators to move disks around without worrying about issues such as SCSI disk reordering or getting the `/dev/device` wrong for a shared target. Soon, file system naming will be made as fail-safe as possible. Currently, Linux disk labels are limited to 16 characters. To identify the target within the file system, 8 characters are reserved, leaving 8 characters for the file system name:

```
fssize-MDT0000 or  
fssize-OST0a19
```

To mount by label, use this command:

```
mount -t lustre -L file_system_label /mount_point
```

This is an example of mount-by-label:

```
mds# mount -t lustre -L testfs-MDT0000 /mnt/mdt
```

Caution

Mount-by-label should NOT be used in a multi-path environment or when snapshots are being created of the device, since multiple block devices will have the same label.

Although the file system name is internally limited to 8 characters, you can mount the clients at any mount point, so file system users are not subjected to short names. Here is an example:

```
client# mount -t lustre mds0@tcp0:/short /dev/long_mountpoint_name
```

13.2. Starting Lustre

On the first start of a Lustre file system, the components must be started in the following order:

1. Mount the MGT.

Note

If a combined MGT/MDT is present, Lustre will correctly mount the MGT and MDT automatically.

2. Mount the MDT.

Note

Mount all MDTs if multiple MDTs are present.

3. Mount the OST(s).
4. Mount the client(s).

13.3. Mounting a Server

Starting a Lustre server is straightforward and only involves the mount command. Lustre servers can be added to `/etc/fstab`:

```
mount -t lustre
```

The mount command generates output similar to this:

```
/dev/sda1 on /mnt/test/mdt type lustre (rw)
/dev/sda2 on /mnt/test/ost0 type lustre (rw)
192.168.0.21@tcp:/testfs on /mnt/testfs type lustre (rw)
```

In this example, the MDT, an OST (`ost0`) and file system (`testfs`) are mounted.

```
LABEL=testfs-MDT0000 /mnt/test/mdt lustre defaults,_netdev,noauto 0 0
LABEL=testfs-OST0000 /mnt/test/ost0 lustre defaults,_netdev,noauto 0 0
```

In general, it is wise to specify `noauto` and let your high-availability (HA) package manage when to mount the device. If you are not using failover, make sure that networking has been started before mounting a Lustre server. If you are running Red Hat Enterprise Linux, SUSE Linux Enterprise Server, Debian operating system (and perhaps others), use the `_netdev` flag to ensure that these disks are mounted after the network is up, unless you are using `systemd 232` or greater, which recognize `lustre` as a network filesystem. If you are using `lnet.service`, use `x-systemd.requires=lnet.service` regardless of `systemd` version.

We are mounting by disk label here. The label of a device can be read with `e2label`. The label of a newly-formatted Lustre server may end in `FFFF` if the `--index` option is not specified to `mkfs.lustre`, meaning that it has yet to be assigned. The assignment takes place when the server is first started, and the disk label is updated. It is recommended that the `--index` option always be used, which will also ensure that the label is set at format time.

Caution

Do not do this when the client and OSS are on the same node, as memory pressure between the client and OSS can lead to deadlocks.

Caution

Mount-by-label should NOT be used in a multi-path environment.

13.4. Stopping the Filesystem

A complete Lustre filesystem shutdown occurs by unmounting all clients and servers in the order shown below. Please note that unmounting a block device causes the Lustre software to be shut down on that node.

Note

Please note that the `-a -t lustre` in the commands below is not the name of a filesystem, but rather is specifying to unmount all entries in `/etc/mntab` that are of type `lustre`

1. Unmount the clients

On each client node, unmount the filesystem on that client using the `umount` command:

```
umount -a -t lustre
```

The example below shows the unmount of the `testfs` filesystem on a client node:

```
[root@client1 ~]# mount -t lustre
XXX.XXX.0.11@tcp:/testfs on /mnt/testfs type lustre (rw,lazystatfs)

[root@client1 ~]# umount -a -t lustre
[154523.177714] Lustre: Unmounted testfs-client
```

2. Unmount the MDT and MGT

On the MGS and MDS node(s), run the `umount` command:

```
umount -a -t lustre
```

The example below shows the unmount of the MDT and MGT for the `testfs` filesystem on a combined MGS/MDS:

```
[root@mds1 ~]# mount -t lustre
/dev/sda on /mnt/mgt type lustre (ro)
/dev/sdb on /mnt/mdt type lustre (ro)

[root@mds1 ~]# umount -a -t lustre
[155263.566230] Lustre: Failing over testfs-MDT0000
[155263.775355] Lustre: server umount testfs-MDT0000 complete
[155269.843862] Lustre: server umount MGS complete
```

For a separate MGS and MDS, the same command is used, first on the MDS and then followed by the MGS.

3. Unmount all the OSTs

On each OSS node, use the `umount` command:

```
umount -a -t lustre
```

The example below shows the unmount of all OSTs for the `testfs` filesystem on server OSS1:

```
[root@oss1 ~]# mount |grep lustre
/dev/sda on /mnt/ost0 type lustre (ro)
/dev/sdb on /mnt/ost1 type lustre (ro)
/dev/sdc on /mnt/ost2 type lustre (ro)
```

```
[root@oss1 ~]# umount -a -t lustre
Lustre: Failing over testfs-OST0002
Lustre: server umount testfs-OST0002 complete
```

For unmount command syntax for a single OST, MDT, or MGT target please refer to Section 13.5, “Unmounting a Specific Target on a Server”

13.5. Unmounting a Specific Target on a Server

To stop a Lustre OST, MDT, or MGT, use the `umount /mount_point` command.

The example below stops an OST, `ost0`, on mount point `/mnt/ost0` for the `testfs` filesystem:

```
[root@oss1 ~]# umount /mnt/ost0
Lustre: Failing over testfs-OST0000
Lustre: server umount testfs-OST0000 complete
```

Gracefully stopping a server with the `umount` command preserves the state of the connected clients. The next time the server is started, it waits for clients to reconnect, and then goes through the recovery procedure.

If the force (`-f`) flag is used, then the server evicts all clients and stops **WITHOUT** recovery. Upon restart, the server does not wait for recovery. Any currently connected clients receive I/O errors until they reconnect.

Note

If you are using loopback devices, use the `-d` flag. This flag cleans up loop devices and can always be safely specified.

13.6. Specifying Failout/Failover Mode for OSTs

In a Lustre file system, an OST that has become unreachable because it fails, is taken off the network, or is unmounted can be handled in one of two ways:

- In `failout` mode, Lustre clients immediately receive errors (EIOs) after a timeout, instead of waiting for the OST to recover.
- In `failover` mode, Lustre clients wait for the OST to recover.

By default, the Lustre file system uses `failover` mode for OSTs. To specify `failout` mode instead, use the `--param="failover.mode=failout"` option as shown below (entered on one line):

```
oss# mkfs.lustre --fsname=fsname --mgsnode=mgs_NID \  
      --param=failover.mode=failout --ost --index=ost_index /dev/ost_block_device
```

In the example below, `failout` mode is specified for the OSTs on the MGS `mds0` in the file system `testfs`(entered on one line).

```
oss# mkfs.lustre --fsname=testfs --mgsnode=mds0 --param=failover.mode=failout \  
      --ost --index=3 /dev/sdb
```

Caution

Before running this command, unmount all OSTs that will be affected by a change in `failover/failout` mode.

Note

After initial file system configuration, use the `tunefs.lustre` utility to change the mode. For example, to set the `failout` mode, run:

```
# tunefs.lustre --param failover.mode=failout /dev/ost_device
```

13.7. Handling Degraded OST RAID Arrays

Lustre includes functionality that notifies Lustre if an external RAID array has degraded performance (resulting in reduced overall file system performance), either because a disk has failed and not been replaced, or because a disk was replaced and is undergoing a rebuild. To avoid a global performance slowdown due to a degraded OST, the MDS can avoid the OST for new object allocation if it is notified of the degraded state.

A parameter for each OST, called `degraded`, specifies whether the OST is running in degraded mode or not.

To mark the OST as degraded, use:

```
oss# lctl set_param obdfilter.{OST_name}.degraded=1
```

To mark that the OST is back in normal operation, use:

```
oss# lctl set_param obdfilter.{OST_name}.degraded=0
```

To determine if OSTs are currently in degraded mode, use:

```
oss# lctl get_param obdfilter.*.degraded
```

If the OST is remounted due to a reboot or other condition, the flag resets to 0.

It is recommended that this be implemented by an automated script that monitors the status of individual RAID devices, such as MD-RAID's `mdadm(8)` command with the `--monitor` option to mark an affected device degraded or restored.

13.8. Running Multiple Lustre File Systems

Lustre supports multiple file systems provided the combination of `NID:fsname` is unique. Each file system must be allocated a unique name during creation with the `--fsname` parameter. Unique names for file systems are enforced if a single MGS is present. If multiple MGSs are present (for example if you

have an MGS on every MDS) the administrator is responsible for ensuring file system names are unique. A single MGS and unique file system names provides a single point of administration and allows commands to be issued against the file system even if it is not mounted.

Lustre supports multiple file systems on a single MGS. With a single MGS fsnames are guaranteed to be unique. Lustre also allows multiple MGSs to co-exist. For example, multiple MGSs will be necessary if multiple file systems on different Lustre software versions are to be concurrently available. With multiple MGSs additional care must be taken to ensure file system names are unique. Each file system should have a unique fsname among all systems that may interoperate in the future.

By default, the `mkfs.lustre` command creates a file system named `lustre`. To specify a different file system name (limited to 8 characters) at format time, use the `--fsname` option:

```
oss# mkfs.lustre --fsname=file_system_name
```

Note

The MDT, OSTs and clients in the new file system must use the same file system name (prepended to the device name). For example, for a new file system named `foo`, the MDT and two OSTs would be named `foo-MDT0000`, `foo-OST0000`, and `foo-OST0001`.

To mount a client on the file system, run:

```
client# mount -t lustre mgsnode:/new_fsname /mount_point
```

For example, to mount a client on file system `foo` at mount point `/mnt/foo`, run:

```
client# mount -t lustre mgsnode:/foo /mnt/foo
```

Note

If a client(s) will be mounted on several file systems, add the following line to `/etc/xattr.conf` file to avoid problems when files are moved between the file systems: `lustre.* skip`

Note

To ensure that a new MDT is added to an existing MGS create the MDT by specifying: `--mdt --mgsnode=mgs_NID`.

A Lustre installation with two file systems (`foo` and `bar`) could look like this, where the MGS node is `mgsnode@tcp0` and the mount points are `/mnt/foo` and `/mnt/bar`.

```
mgsnode# mkfs.lustre --mgs /dev/sda
mdtfoonode# mkfs.lustre --fsname=foo --mgsnode=mgsnode@tcp0 --mdt --index=0
/dev/sdb
ossfoonode# mkfs.lustre --fsname=foo --mgsnode=mgsnode@tcp0 --ost --index=0
/dev/sda
ossfoonode# mkfs.lustre --fsname=foo --mgsnode=mgsnode@tcp0 --ost --index=1
/dev/sdb
mdtbarnode# mkfs.lustre --fsname=bar --mgsnode=mgsnode@tcp0 --mdt --index=0
```



```

/dev/sda
ossbarnode# mkfs.lustre --fsname=bar --mgsnode=mgsnode@tcp0 --ost --index=0
/dev/sdc
ossbarnode# mkfs.lustre --fsname=bar --mgsnode=mgsnode@tcp0 --ost --index=1
/dev/sdd

```

To mount a client on file system foo at mount point `/mnt/foo`, run:

```
client# mount -t lustre mgsnode@tcp0:/foo /mnt/foo
```

To mount a client on file system bar at mount point `/mnt/bar`, run:

```
client# mount -t lustre mgsnode@tcp0:/bar /mnt/bar
```

13.9. Creating a sub-directory on a specific MDT

It is possible to create individual directories, along with its files and sub-directories, to be stored on specific MDTs. To create a sub-directory on a given MDT use the command:

```
client$ lfs mkdir -i mdt_index /mount_point/remote_dir
```

This command will allocate the sub-directory `remote_dir` onto the MDT with index `mdt_index`. For more information on adding additional MDTs and `mdt_index` see 2.

Warning

An administrator can allocate remote sub-directories to separate MDTs. Creating remote sub-directories in parent directories not hosted on MDT0000 is not recommended. This is because the failure of the parent MDT will leave the namespace below it inaccessible. For this reason, by default it is only possible to create remote sub-directories off MDT0000. To relax this restriction and enable remote sub-directories off any MDT, an administrator must issue the following command on the MGS:

```
mgs# lctl set_param -P mdt.fsname-MDT*.enable_remote_dir=1
```

For Lustre filesystem 'scratch', the command executed is:

```
mgs# lctl set_param -P mdt.scratch-*.enable_remote_dir=1
```

To verify the configuration setting execute the following command on any MDS:

```
mgs# lctl get_param mdt.*.enable_remote_dir
```

Introduced in Lustre 2.8

With Lustre software version 2.8, a new tunable is available to allow users with a specific group ID to create and delete remote and striped directories. This tunable is `enable_remote_dir_gid`. For example,

setting this parameter to the 'wheel' or 'admin' group ID allows users with that GID to create and delete remote and striped directories. Setting this parameter to -1 on MDT0000 to permanently allow any non-root users create and delete remote and striped directories. On the MGS execute the following command:

```
mgs# lctl set_param -P mdt.fsname-*.enable_remote_dir_gid=-1
```

For the Lustre filesystem 'scratch', the command expands to:

```
mgs# lctl set_param -P mdt.scratch-*.enable_remote_dir_gid=-1
```

The change can be verified by executing the following command on every MDS:

```
mgs# lctl get_param mdt.*.enable_remote_dir_gid
```

Introduced in Lustre 2.8

13.10. Creating a directory striped across multiple MDTs

The Lustre 2.8 DNE feature enables files in a single large directory to be distributed across multiple MDTs (a *striped directory*), if there are multiple MDTs added to the filesystem, see Section 14.7, “Adding a New MDT to a Lustre File System”. The result is that metadata requests for files in a single large striped directory are serviced by multiple MDTs and metadata service load is distributed over all the MDTs that service a given directory. By distributing metadata service load over multiple MDTs, performance of very large directories can be improved beyond the limit of one MDT. Normally, all files in a directory must be created on a single MDT.

This command to stripe a directory over *mdt_count* MDTs is:

```
client$ lfs mkdir -c mdt_count /mount_point/new_directory
```

The striped directory feature is most useful for distributing a single large directory (50k entries or more) across multiple MDTs. This should be used with discretion since creating and removing striped directories incurs more overhead than non-striped directories.

Introduced in Lustre 2.13

13.10.1. Directory creation by space/inode usage

If the starting MDT is not specified when creating a new directory, this directory and its stripes will be distributed on MDTs by space usage. For example the following will create a new directory on an MDT preferring one that has less space usage:

```
client$ lfs mkdir -c 1 -i -1 dir1
```

Alternatively, if a default directory stripe is set on a directory, the subsequent use of `mkdir` for subdirectories in *dir1* will have the same effect:

```
client$ lfs setdirstripe -D -c 1 -i -1 dir1
```

The policy is:

- If free inodes/blocks on all MDT are almost the same, i.e. $\text{max_inodes_avail} * 84\% < \text{min_inodes_avail}$ and $\text{max_blocks_avail} * 84\% < \text{min_blocks_avail}$, then choose MDT roundrobin.
- Otherwise, create more subdirectories on MDTs with more free inodes/blocks.

Sometime there are many MDTs. But it is not always desirable to stripe a directory across all MDTs, even if the directory default `stripe_count=-1` (unlimited). In this case, the per-filesystem tunable parameter `lod.*.max_mdt_stripecount` can be used to limit the actual stripe count of directory to fewer than the full MDT count. If `lod.*.max_mdt_stripecount` is not 0, and the directory `stripe_count=-1`, the real directory stripe count will be the minimum of the number of MDTs and `max_mdt_stripecount`. If `lod.*.max_mdt_stripecount=0`, or an explicit stripe count is given for the directory, it is ignored.

To set `max_mdt_stripecount`, on all MDSEs of file system, run:

```
mgs# lctl set_param -P lod.$fsname-MDTxxxx-mdtlov.max_mdt_stripecount=<N>
```

To check `max_mdt_stripecount`, run:

```
mgs# lctl get_param lod.$fsname-MDTxxxx-mdtlov.max_mdt_stripecount
```

To reset `max_mdt_stripecount`, run:

```
mgs# lctl set_param -P -d lod.$fsname-MDTxxxx-mdtlov.max_mdt_stripecount
```

Introduced in Lustre 2.14

13.10.2. Filesystem-wide default directory striping

Similar to file objects allocation, the directory objects are allocated on MDTs by a round-robin algorithm or a weighted algorithm. For the top three level of directories from the root of the filesystem, if the amount of free inodes and blocks is well balanced (i.e., by default, when the free inodes and blocks across MDTs differ by less than 5%), the round-robin algorithm is used to select the next MDT on which a directory is to be created.

If the directory is more than three levels below the root directory, or MDTs are not balanced, then the weighted algorithm is used to randomly select an MDT with more free inodes and blocks.

To avoid creating unnecessary remote directories, if the MDT where its parent directory is located is not too full (the free inodes and blocks of the parent MDT is not more than 5% full than average of all MDTs), this directory will be created on parent MDT.

If administrator wants to change this default filesystem-wide directory striping, run the following command to limit this striping to the top level below the root directory:

```
client$ lfs setdirstripe -D -i -1 -c 1 --max-inherit 0 <mountpoint>
```

To revert to the pre-2.15 behavior of all directories being created only on MDT0000 by default (deleting this striping won't work because it will be recreated if missing):

```
client$ lfs setdirstripe -D -i 0 -c 1 --max-inherit 0 <mountpoint>
```

13.11. Default Dir Stripe Policy

If default dir stripe policy is set to a directory, it will be applied to sub directories created later. For example:

```
$ mkdir testdir1
$ lfs setdirstripe testdir1 -D -c 2
$ lfs getdirstripe testdir1 -D
lmv_stripe_count: 2 lmv_stripe_offset: -1 lmv_hash_type: none lmv_max_inherit: 3 1
$ mkdir dir1/subdir1
$ lfs getdirstripe testdir1/subdir1
lmv_stripe_count: 2 lmv_stripe_offset: 0 lmv_hash_type: crush
mdtidx      FID[seq:oid:ver]
  0          [0x200000400:0x2:0x0]
  1          [0x240000401:0x2:0x0]
```

Default dir stripe can be inherited by sub directory. This behavior is controlled by `lmv_max_inherit` parameter. If `lmv_max_inherit` is 0 or 1, sub directory stops to inherit default dir stripe policy. Or sub directory decreases its parent's `lmv_max_inherit` and uses it as its own `lmv_max_inherit`. -1 is special because it means unlimited. For example:

```
$ lfs getdirstripe testdir1/subdir1 -D
lmv_stripe_count: 2 lmv_stripe_offset: -1 lmv_hash_type: none lmv_max_inherit: 2 1
```

`lmv_max_inherit` can be set explicitly with `--max-inherit` option in `lfs setdirstripe -D` command. If the max-inherit value is not specified, the default value is -1 when `stripe_count` is 0 or 1. For other values of `stripe_count`, the default value is 3.

13.12. Setting and Retrieving Lustre Parameters

Several options are available for setting parameters in Lustre:

- When creating a file system, use `mkfs.lustre`. See Section 13.12.1, “Setting Tunable Parameters with `mkfs.lustre`” below.
- When a server is stopped, use `tunefs.lustre`. See Section 13.12.2, “Setting Parameters with `tunefs.lustre`” below.
- When the file system is running, use `lctl` to set or retrieve Lustre parameters. See Section 13.12.3, “Setting Parameters with `lctl`” and Section 13.12.3.6, “Reporting Current Parameter Values” below.

13.12.1. Setting Tunable Parameters with `mkfs.lustre`

When the file system is first formatted, parameters can simply be added as a `--param` option to the `mkfs.lustre` command. For example:

```
mgs# mkfs.lustre --mdt --param="sys.timeout=50" /dev/sda
```

For more details about creating a file system, see Chapter 10, *Configuring a Lustre File System*. For more details about `mkfs.lustre`, see Chapter 44, *System Configuration Utilities*.

13.12.2. Setting Parameters with `tunefs.lustre`

If a server (OSS or MDS) is stopped, parameters can be added to an existing file system using the `--param` option to the `tunefs.lustre` command. For example:

```
oss# tunefs.lustre --param=failover.node=192.168.0.13@tcp0 /dev/sda
```

With `tunefs.lustre`, parameters are *additive*-- new parameters are specified in addition to old parameters, they do not replace them. To erase all old `tunefs.lustre` parameters and just use newly-specified parameters, run:

```
mgs# tunefs.lustre --erase-params --param=new_parameters
```

The `tunefs.lustre` command can be used to set any parameter settable via `lctl conf_param` and that has its own OBD device, so it can be specified as `obdname/fsname.obdtype.proc_file_name=value`. For example:

```
mgs# tunefs.lustre --param mdt.identity_upcall=NONE /dev/sda1
```

For more details about `tunefs.lustre`, see Chapter 44, *System Configuration Utilities*.

13.12.3. Setting Parameters with `lctl`

When the file system is running, the `lctl` command can be used to set parameters (temporary or permanent) and report current parameter values. Temporary parameters are active as long as the server or client is not shut down. Permanent parameters live through server and client reboots.

Note

The `lctl list_param` command enables users to list all parameters that can be set. See Section 13.12.3.5, “Listing All Tunable Parameters”.

For more details about the `lctl` command, see the examples in the sections below and Chapter 44, *System Configuration Utilities*.

13.12.3.1. Setting Temporary Parameters

Use `lctl set_param` to set temporary parameters on the node where it is run. These parameters internally map to corresponding items in the kernel `/proc/{fs,sys}/{lnet,lustre}` and `/sys/{fs,kernel/debug}/lustre` virtual filesystems. However, since the mapping between a particular

parameter name and the underlying virtual pathname may change, it is *not* recommended to access the virtual pathname directly. The `lctl set_param` command uses this syntax:

```
# lctl set_param [-n] [-P] obdtype.obdname.proc_file_name=value
```

For example:

```
# lctl set_param osc.*.max_dirty_mb=1024
osc.myth-OST0000-osc.max_dirty_mb=32
osc.myth-OST0001-osc.max_dirty_mb=32
osc.myth-OST0002-osc.max_dirty_mb=32
osc.myth-OST0003-osc.max_dirty_mb=32
osc.myth-OST0004-osc.max_dirty_mb=32
```

13.12.3.2. Setting Permanent Parameters

Use `lctl set_param -P` or `lctl conf_param` command to set permanent parameters. In general, the `set_param -P` command is preferred for new parameters, as this isolates the parameter settings from the MDT and OST device configuration, and is consistent with the common `lctl get_param` and `lctl set_param` commands. The `lctl conf_param` command was previously used to specify settable parameter, with the following syntax (the same as the `mkfs.lustre` and `tunefs.lustre` commands):

```
obdtype/fsname.obdtype.proc_file_name=value)
```

Note

The `lctl conf_param` and `lctl set_param` syntax is *not* the same.

Here are a few examples of `lctl conf_param` commands:

```
mgs# lctl conf_param testfs-MDT0000.sys.timeout=40
mgs# lctl conf_param testfs-MDT0000.mdt.identity_upcall=NONE
mgs# lctl conf_param testfs.llite.max_read_ahead_mb=16
mgs# lctl conf_param testfs-OST0000.osc.max_dirty_mb=29.15
mgs# lctl conf_param testfs-OST0000.ost.client_cache_seconds=15
mgs# lctl conf_param testfs.sys.timeout=40
```

Caution

Parameters specified with the `lctl conf_param` command are set permanently in the file system's configuration file on the MGS.

Introduced in Lustre 2.5

13.12.3.3. Setting Permanent Parameters with `lctl set_param -P`

The `lctl set_param -P` command can also set parameters permanently using the same syntax as `lctl set_param` and `lctl get_param` commands. Permanent parameter settings must be issued

on the MGS. The given parameter is set on every host using `lctl upcall`. The `lctl set_param` command uses the following syntax:

```
lctl set_param -P obdtype.obdname.proc_file_name=value
```

For example:

```
mgs# lctl set_param -P timeout=40
mgs# lctl set_param -P mdt.testfs-MDT*.identity_upcall=NONE
mgs# lctl set_param -P llite.testfs-*.max_read_ahead_mb=16
mgs# lctl set_param -P osc.testfs-OST*.max_dirty_mb=29.15
mgs# lctl set_param -P ost.testfs-OST*.client_cache_seconds=15
```

Use the `-P -d` option to delete permanent parameters. Syntax:

```
lctl set_param -P -d obdtype.obdname.parameter_name
```

For example:

```
mgs# lctl set_param -P -d osc.*.max_dirty_mb
```

Introduced in before Lustre 2.5

Note

Starting in Lustre 2.12, there is `lctl get_param` command can provide *tab completion* when using an interactive shell with `bash-completion` installed. This simplifies the use of `get_param` significantly, since it provides an interactive list of available parameters.

13.12.3.4. Listing Persistent Parameters

To list tunable parameters stored in the `params` log file by `lctl set_param -P` and applied to nodes at mount, run the `lctl --device MGS llog_print params` command on the MGS. For example:

```
mgs# lctl --device MGS llog_print params
- { index: 2, event: set_param, device: general, parameter: osc.*.max_dirty_mb, va
```

13.12.3.5. Listing All Tunable Parameters

To list Lustre or LNet parameters that are available to set, use the `lctl list_param` command. For example:

```
lctl list_param [-FR] obdtype.obdname
```

The following arguments are available for the `lctl list_param` command.

-F Add '/', '@' or '=' for directories, symlinks and writeable files, respectively

-R Recursively lists all parameters under the specified path

For example:

```
oss# lctl list_param obdfilter.lustre-OST0000
```

13.12.3.6. Reporting Current Parameter Values

To report current Lustre parameter values, use the `lctl get_param` command with this syntax:

```
lctl get_param [-n] obdtype.obdname.proc_file_name
```

Introduced in before Lustre 2.5

Note

Starting in Lustre 2.12, there is `lctl get_param` command can provide *tab completion* when using an interactive shell with `bash-completion` installed. This simplifies the use of `get_param` significantly, since it provides an interactive list of available parameters.

This example reports data on RPC service times.

```
oss# lctl get_param -n ost.*.ost_io.timeouts
service : cur 1 worst 30 (at 1257150393, 85d23h58m54s ago) 1 1 1 1
```

This example reports the amount of space this client has reserved for writeback cache with each OST:

```
client# lctl get_param osc.*.cur_grant_bytes
osc.myth-OST0000-osc-ffff8800376bdc00.cur_grant_bytes=2097152
osc.myth-OST0001-osc-ffff8800376bdc00.cur_grant_bytes=33890304
osc.myth-OST0002-osc-ffff8800376bdc00.cur_grant_bytes=35418112
osc.myth-OST0003-osc-ffff8800376bdc00.cur_grant_bytes=2097152
osc.myth-OST0004-osc-ffff8800376bdc00.cur_grant_bytes=33808384
```

13.13. Specifying NIDs and Failover

If a node has multiple network interfaces, it may have multiple NIDs, which must all be identified so other nodes can choose the NID that is appropriate for their network interfaces. Typically, NIDs are specified in a list delimited by commas (,). However, when failover nodes are specified, the NIDs are delimited by a colon (:) or by repeating a keyword such as `--mgsnode=` or `--servicenode=`.

To display the NIDs of all servers in networks configured to work with the Lustre file system, run (while LNet is running):

```
# lctl list_nids
```

In the example below, `mds0` and `mds1` are configured as a combined MGS/MDT failover pair and `oss0` and `oss1` are configured as an OST failover pair. The Ethernet address for `mds0` is 192.168.10.1, and for `mds1` is 192.168.10.2. The Ethernet addresses for `oss0` and `oss1` are 192.168.10.20 and 192.168.10.21 respectively.

```

mds0# mkfs.lustre --fsname=testfs --mdt --mgs \
      --servicenode=192.168.10.2@tcp0 \
      --servicenode=192.168.10.1@tcp0 /dev/sda1
mds0# mount -t lustre /dev/sda1 /mnt/test/mdt
oss0# mkfs.lustre --fsname=testfs --servicenode=192.168.10.20@tcp0 \
      --servicenode=192.168.10.21 --ost --index=0 \
      --mgsnode=192.168.10.1@tcp0 --mgsnode=192.168.10.2@tcp0 \
      /dev/sdb
oss0# mount -t lustre /dev/sdb /mnt/test/ost0
client# mount -t lustre 192.168.10.1@tcp0:192.168.10.2@tcp0:/testfs \
        /mnt/testfs
mds0# umount /mnt/mdt
mds1# mount -t lustre /dev/sda1 /mnt/test/mdt
mds1# lctl get_param mdt.testfs-MDT0000.recovery_status

```

Where multiple NIDs are specified separated by commas (for example, `10.67.73.200@tcp,192.168.10.1@tcp`), the two NIDs refer to the same host, and the Lustre software chooses the *best* one for communication. When a pair of NIDs is separated by a colon (for example, `10.67.73.200@tcp:10.67.73.201@tcp`), the two NIDs refer to two different hosts and are treated as a failover pair (the Lustre software tries the first one, and if that fails, it tries the second one.)

Two options to `mkfs.lustre` can be used to specify failover nodes. The `--servicenode` option is used to specify all service NIDs, including those for primary nodes and failover nodes. When the `--servicenode` option is used, the first service node to load the target device becomes the primary service node, while nodes corresponding to the other specified NIDs become failover locations for the target device. An older option, `--failnode`, specifies just the NIDs of failover nodes. For more information about the `--servicenode` and `--failnode` options, see Chapter 11, *Configuring Failover in a Lustre File System*.

13.14. Erasing a File System

If you want to erase a file system and permanently delete all the data in the file system, run this command on your targets:

```
# mkfs.lustre --reformat
```

If you are using a separate MGS and want to keep other file systems defined on that MGS, then set the `writeconf` flag on the MDT for that file system. The `writeconf` flag causes the configuration logs to be erased; they are regenerated the next time the servers start.

To set the `writeconf` flag on the MDT:

1. Unmount all clients/servers using this file system, run:

```
client# umount /mnt/lustre
```

2. Permanently erase the file system and, presumably, replace it with another file system, run:

```
mgs# mkfs.lustre --reformat --fsname spfs --mgs --mdt --index=0 /dev/mdsdev
```

3. If you have a separate MGS (that you do not want to reformat), then add the `--writeconf` flag to `mkfs.lustre` on the MDT, run:

```
mgs# mkfs.lustre --reformat --writeconf --fsname spfs --mgsnode=mgs_nid \  
--mdt --index=0 /dev/mds_device
```

Note

If you have a combined MGS/MDT, reformatting the MDT reformats the MGS as well, causing all configuration information to be lost; you can start building your new file system. Nothing needs to be done with old disks that will not be part of the new file system, just do not mount them.

13.15. Reclaiming Reserved Disk Space

All current Lustre installations run the `ldiskfs` file system internally on service nodes. By default, `ldiskfs` reserves 5% of the disk space to avoid file system fragmentation. In order to reclaim this space, run the following command on your OSS for each OST in the file system:

```
# tune2fs [-m reserved_blocks_percent] /dev/ostdev
```

You do not need to shut down Lustre before running this command or restart it afterwards.

Warning

Reducing the space reservation can cause severe performance degradation as the OST file system becomes more than 95% full, due to difficulty in locating large areas of contiguous free space. This performance degradation may persist even if the space usage drops below 95% again. It is recommended NOT to reduce the reserved disk space below 5%.

13.16. Replacing an Existing OST or MDT

To copy the contents of an existing OST to a new OST (or an old MDT to a new MDT), follow the process for either OST/MDT backups in Section 18.2, “Backing Up and Restoring an MDT or OST (ldiskfs Device Level)” or Section 18.3, “Backing Up an OST or MDT (Backend File System Level)”. For more information on removing a MDT, see Section 14.9.1, “Removing an MDT from the File System”.

13.17. Identifying To Which Lustre File an OST Object Belongs

Use this procedure to identify the file containing a given object on a given OST.

1. On the OST (as root), run `debugfs` to display the file identifier (FID) of the file associated with the object.

For example, if the object is 34976 on `/dev/lustre/ost_test2`, the debug command is:

```
# debugfs -c -R "stat /O/O/d$((34976 % 32))/34976" /dev/lustre/ost_test2
```

The command output is:

```

debugfs 1.45.6.wc1 (20-Mar-2020)
/dev/lustre/ost_test2: catastrophic mode - not reading inode or group bitmaps
Inode: 352365   Type: regular   Mode: 0666   Flags: 0x80000
Generation: 2393149953   Version: 0x0000002a:00005f81
User: 1000   Group: 1000   Size: 260096
File ACL: 0   Directory ACL: 0
Links: 1   Blockcount: 512
Fragment: Address: 0   Number: 0   Size: 0
ctime: 0x4a216b48:00000000 -- Sat May 30 13:22:16 2009
atime: 0x4a216b48:00000000 -- Sat May 30 13:22:16 2009
mtime: 0x4a216b48:00000000 -- Sat May 30 13:22:16 2009
crttime: 0x4a216b3c:975870dc -- Sat May 30 13:22:04 2009
Size of extra inode fields: 24
Extended attributes stored in inode body:
  fid = "b9 da 24 00 00 00 00 00 6a fa 0d 3f 01 00 00 00 eb 5b 0b 00 00 00 0000
00 00 00 00 00 00 00 00 " (32)
  fid: objid=34976 seq=0 parent=[0x200000400:0x122:0x0] stripe=1
EXTENTS:
(0-64):4620544-4620607

```

2. The parent FID will be of the form [0x200000400:0x122:0x0] and can be resolved directly using the command `lfs fid2path [0x200000404:0x122:0x0] /mnt/lustre` on any Lustre client, and the process is complete.
3. In cases of an upgraded 1.x inode (if the first part of the FID is below 0x200000400), the MDT inode number is 0x24dab9 and generation 0x3f0dfa6a and the pathname can also be resolved using `debugfs`.
4. On the MDS (as root), use `debugfs` to find the file associated with the inode:

```

# debugfs -c -R "ncheck 0x24dab9" /dev/lustre/mdt_test
debugfs 1.42.3.wc3 (15-Aug-2012)
/dev/lustre/mdt_test: catastrophic mode - not reading inode or group bitmaps
Inode      Pathname
2415289    /ROOT/brian-laptop-guest/clients/client11/~dmtmp/PWRPNT/ZD16.BMP

```

The command lists the inode and pathname associated with the object.

Note

`Debugfs`' `ncheck` is a brute-force search that may take a long time to complete.

Note

To find the Lustre file from a disk LBA, follow the steps listed in the document at this URL: <https://www.smartmontools.org/wiki/BadBlockHowto> [<https://www.smartmontools.org/wiki/BadBlockHowto>]. Then, follow the steps above to resolve the Lustre filename.

Chapter 14. Lustre Maintenance

Once you have the Lustre file system up and running, you can use the procedures in this section to perform these basic Lustre maintenance tasks:

- Section 14.1, “ Working with Inactive OSTs”
- Section 14.2, “ Finding Nodes in the Lustre File System”
- Section 14.3, “ Mounting a Server Without Lustre Service”
- Section 14.4, “ Regenerating Lustre Configuration Logs”
- Section 14.5, “ Changing a Server NID”
- Section 14.6, “ Clearing configuration”
- Section 14.7, “Adding a New MDT to a Lustre File System”
- Section 14.8, “ Adding a New OST to a Lustre File System”
- Section 14.9, “ Removing and Restoring MDTs and OSTs”
- Section 14.9.1, “Removing an MDT from the File System”
- Section 14.9.2, “ Working with Inactive MDTs”
- Section 14.9.3, “Removing an OST from the File System”
- Section 14.9.4, “ Backing Up OST Configuration Files”
- Section 14.9.5, “ Restoring OST Configuration Files”
- Section 14.9.6, “Returning a Deactivated OST to Service”
- Section 14.10, “ Aborting Recovery”
- Section 14.11, “ Determining Which Machine is Serving an OST ”
- Section 14.12, “ Changing the Address of a Failover Node”
- Section 14.13, “ Separate a combined MGS/MDT”
- Section 14.14, “ Set an MDT to read-only”
- Section 14.15, “ Tune Fallocate for ldiskfs”

14.1. Working with Inactive OSTs

To mount a client or an MDT with one or more inactive OSTs, run commands similar to this:

```
client# mount -o exclude=testfs-OST0000 -t lustre \  
            uml1:/testfs /mnt/testfs  
client# lctl get_param lov.testfs-clilov-*.target_obd
```

To activate an inactive OST on a live client or MDT, use the `lctl activate` command on the OSC device. For example:

```
lctl --device 7 activate
```

Note

A colon-separated list can also be specified. For example, `exclude=testfs-OST0000:testfs-OST0001`.

14.2. Finding Nodes in the Lustre File System

There may be situations in which you need to find all nodes in your Lustre file system or get the names of all OSTs.

To get a list of all Lustre nodes, run this command on the MGS:

```
# lctl get_param mgs.MGS.live.*
```

Note

This command must be run on the MGS.

In this example, file system `testfs` has three nodes, `testfs-MDT0000`, `testfs-OST0000`, and `testfs-OST0001`.

```
mgs:/root# lctl get_param mgs.MGS.live.*
          fsname: testfs
          flags: 0x0      gen: 26
          testfs-MDT0000
          testfs-OST0000
          testfs-OST0001
```

To get the names of all OSTs, run this command on the MDS:

```
mgs:/root# lctl get_param lov.*-mdtlov.target_obd
```

Note

This command must be run on the MDS.

In this example, there are two OSTs, `testfs-OST0000` and `testfs-OST0001`, which are both active.

```
mgs:/root# lctl get_param lov.testfs-mdtlov.target_obd
0: testfs-OST0000_UUID ACTIVE
1: testfs-OST0001_UUID ACTIVE
```

14.3. Mounting a Server Without Lustre Service

If you are using a combined MGS/MDT, but you only want to start the MGS and not the MDT, run this command:

```
mount -t lustre /dev/mdt_partition -o nosvc /mount_point
```

The `mdt_partition` variable is the combined MGS/MDT block device.

In this example, the combined MGS/MDT is `testfs-MDT0000` and the mount point is `/mnt/test/mdt`.

```
$ mount -t lustre -L testfs-MDT0000 -o nosvc /mnt/test/mdt
```

14.4. Regenerating Lustre Configuration Logs

If the Lustre file system configuration logs are in a state where the file system cannot be started, use the `tunefs.lustre --writeconf` command to regenerate them. After the `writeconf` command is run and the servers restart, the configuration logs are re-generated and stored on the MGS (as with a new file system).

You should only use the `writeconf` command if:

- The configuration logs are in a state where the file system cannot start
- A server NID is being changed

The `writeconf` command is destructive to some configuration items (e.g. OST pools information and tunables set via `conf_param`), and should be used with caution.

Caution

The OST pools feature enables a group of OSTs to be named for file striping purposes. If you use OST pools, be aware that running the `writeconf` command erases **all** pools information (as well as any other parameters set via `lctl conf_param`). We recommend that the pools definitions (and `conf_param` settings) be executed via a script, so they can be regenerated easily after `writeconf` is performed. However, tunables saved with `lctl set_param -P` are *not* erased in this case.

Note

If the MGS still holds any configuration logs, it may be possible to dump these logs to save any parameters stored with `lctl conf_param` by dumping the config logs on the MGS and saving the output (once for each MDT and OST device):

```
mgs# lctl --device MGS llog_print fsname-client
mgs# lctl --device MGS llog_print fsname-MDT0000
mgs# lctl --device MGS llog_print fsname-OST0000
```

To regenerate Lustre file system configuration logs:

1. Stop the file system services in the following order before running the `tunefs.lustre --writeconf` command:
 - a. Unmount the clients.
 - b. Unmount the MDT(s).
 - c. Unmount the OST(s).

- d. If the MGS is separate from the MDT it can remain mounted during this process.
2. Make sure the MDT and OST devices are available.
3. Run the `tunefs.lustre --writeconf` command on all target devices.

Run `writeconf` on the MDT(s) first, and then the OST(s).

- a. On each MDS, for each MDT run:

```
mgs# tunefs.lustre --writeconf /dev/mdt_device
```

- b. On each OSS, for each OST run:

```
oss# tunefs.lustre --writeconf /dev/ost_device
```

4. Restart the file system in the following order:
 - a. Mount the separate MGT, if it is not already mounted.
 - b. Mount the MDT(s) in order, starting with MDT0000.
 - c. Mount the OSTs in order, starting with OST0000.
 - d. Mount the clients.

After the `tunefs.lustre --writeconf` command is run, the configuration logs are re-generated as servers connect to the MGS.

14.5. Changing a Server NID

In order to totally rewrite the Lustre configuration, the `tunefs.lustre --writeconf` command is used to rewrite all of the configuration files.

If you need to change only the NID of the MDT or OST, the `replace_nids` command can simplify this process. The `replace_nids` command differs from `tunefs.lustre --writeconf` in that it does not erase the entire configuration log, precluding the need to execute the `writeconf` command on all servers and re-specify all permanent parameter settings. However, the `writeconf` command can still be used if desired.

Change a server NID in these situations:

- New server hardware is added to the file system, and the MDS or an OSS is being moved to the new machine.
- New network card is installed in the server.
- You want to reassign IP addresses.

To change a server NID:

1. Update the LNet configuration in the `/etc/modprobe.conf` file so the list of server NIDs is correct. Use `lctl list_nids` to view the list of server NIDS.

The `lctl list_nids` command indicates which network(s) are configured to work with the Lustre file system.

2. Shut down the file system in this order:

- a. Unmount the clients.
- b. Unmount the MDT.
- c. Unmount all OSTs.

3. If the MGS and MDS share a partition, start the MGS only:

```
mount -t lustre MDT partition -o nosvc mount_point
```

4. Run the `replace_nids` command on the MGS:

```
lctl replace_nids devicename nid1[,nid2,nid3 ...]
```

where *devicename* is the Lustre target name, e.g. `testfs-OST0013`

5. If the MGS and MDS share a partition, stop the MGS:

```
umount mount_point
```

Note

The `replace_nids` command also cleans all old, invalidated records out of the configuration log, while preserving all other current settings.

Note

The previous configuration log is backed up on the MGS disk with the suffix `' .bak '`.

Introduced in Lustre 2.11

14.6. Clearing configuration

This command runs on MGS node having the MGS device mounted with `-o nosvc`. It cleans up configuration files stored in the `CONFIGS/` directory of any records marked `SKIP`. If the device name is given, then the specific logs for that filesystem (e.g. `testfs-MDT0000`) are processed. Otherwise, if a filesystem name is given then all configuration files are cleared. The previous configuration log is backed up on the MGS disk with the suffix `'config.timestamp.bak'`. Eg: `Lustre-MDT0000-1476454535.bak`.

To clear a configuration:

1. Shut down the file system in this order:

- a. Unmount the clients.
- b. Unmount the MDT.
- c. Unmount all OSTs.

2. If the MGS and MDS share a partition, start the MGS only using "nosvc" option.

```
mount -t lustre MDT partition -o nosvc mount_point
```

3. Run the `clear_conf` command on the MGS:

```
lctl clear_conf config
```

Example: To clear the configuration for MDT0000 on a filesystem named `testfs`

```
mgs# lctl clear_conf testfs-MDT0000
```

14.7. Adding a New MDT to a Lustre File System

Additional MDTs can be added using the DNE feature to serve one or more remote sub-directories within a filesystem, in order to increase the total number of files that can be created in the filesystem, to increase aggregate metadata performance, or to isolate user or application workloads from other users of the filesystem. It is possible to have multiple remote sub-directories reference the same MDT. However, the root directory will always be located on MDT0000. To add a new MDT into the file system:

1. Discover the maximum MDT index. Each MDT must have unique index.

```
client$ lctl dl | grep mdc
36 UP mdc testfs-MDT0000-mdc-ffff88004edf3c00 4c8be054-144f-9359-b063-8477566eb8
37 UP mdc testfs-MDT0001-mdc-ffff88004edf3c00 4c8be054-144f-9359-b063-8477566eb8
38 UP mdc testfs-MDT0002-mdc-ffff88004edf3c00 4c8be054-144f-9359-b063-8477566eb8
39 UP mdc testfs-MDT0003-mdc-ffff88004edf3c00 4c8be054-144f-9359-b063-8477566eb8
```

2. Add the new block device as a new MDT at the next available index. In this example, the next available index is 4.

```
mgs# mkfs.lustre --reformat --fsname=testfs --mdt --mgsnode=mgsnode --index 4 /dev/
```

3. Mount the MDTs.

```
mgs# mount -t lustre /dev/mdt4_blockdevice /mnt/mdt4
```

4. In order to start creating new files and directories on the new MDT(s) they need to be attached into the namespace at one or more subdirectories using the `lfs mkdir` command. All files and directories below those created with `lfs mkdir` will also be created on the same MDT unless otherwise specified.

```
client# lfs mkdir -i 3 /mnt/testfs/new_dir_on_mdt3
client# lfs mkdir -i 4 /mnt/testfs/new_dir_on_mdt4
client# lfs mkdir -c 4 /mnt/testfs/project/new_large_dir_stripped_over_4_mdts
```

14.8. Adding a New OST to a Lustre File System

A new OST can be added to existing Lustre file system on either an existing OSS node or on a new OSS node. In order to keep client IO load balanced across OSS nodes for maximum aggregate performance, it is not recommended to configure different numbers of OSTs to each OSS node.

1. Add a new OST by using `mkfs.lustre` as when the filesystem was first formatted, see 4 for details. Each new OST must have a unique index number, use `lctl dl` to see a list of all OSTs. For example, to add a new OST at index 12 to the `testfs` filesystem run following commands should be run on the OSS:

```
oss# mkfs.lustre --fsname=testfs --mgsnode=mds16@tcp0 --ost --index=12 /dev/sda
oss# mkdir -p /mnt/testfs/ost12
oss# mount -t lustre /dev/sda /mnt/testfs/ost12
```

2. Balance OST space usage (possibly).

The file system can be quite unbalanced when new empty OSTs are added to a relatively full filesystem. New file creations are automatically balanced to favour the new OSTs. If this is a scratch file system or files are pruned at regular intervals, then no further work may be needed to balance the OST space usage as new files being created will preferentially be placed on the less full OST(s). As old files are deleted, they will release space on the old OST(s).

Files existing prior to the expansion can optionally be rebalanced using the `lfs_migrate` utility. This redistributes file data over the entire set of OSTs.

For example, to rebalance all files within the directory `/mnt/lustre/dir`, enter:

```
client# lfs_migrate /mnt/lustre/dir
```

To migrate files within the `/test` file system on OST0004 that are larger than 4GB in size to other OSTs, enter:

```
client# lfs find /test --ost test-OST0004 -size +4G | lfs_migrate -y
```

See Section 40.2, “`lfs_migrate`” for details.

14.9. Removing and Restoring MDTs and OSTs

OSTs and DNE MDTs can be removed from and restored to a Lustre filesystem. Deactivating an OST means that it is temporarily or permanently marked unavailable. Deactivating an OST on the MDS means it will not try to allocate new objects there or perform OST recovery, while deactivating an OST the client means it will not wait for OST recovery if it cannot contact the OST and will instead return an IO error to the application immediately if files on the OST are accessed. An OST may be permanently deactivated from the file system, depending on the situation and commands used.

Note

A permanently deactivated MDT or OST still appears in the filesystem configuration until the configuration is regenerated with `writeconf` or it is replaced with a new MDT or OST at the same index and permanently reactivated. A deactivated OST will not be listed by `lfs df`.

You may want to temporarily deactivate an OST on the MDS to prevent new files from being written to it in several situations:

- A hard drive has failed and a RAID resync/rebuild is underway, though the OST can also be marked *degraded* by the RAID system to avoid allocating new files on the slow OST which can reduce performance, see Section 13.7, “Handling Degraded OST RAID Arrays” for more details.

- OST is nearing its space capacity, though the MDS will already try to avoid allocating new files on overly-full OSTs if possible, see Section 39.7, “Allocating Free Space on OSTs” for details.
- MDT/OST storage or MDS/OSS node has failed, and will not be available for some time (or forever), but there is still a desire to continue using the filesystem before it is repaired.

14.9.1. Removing an MDT from the File System

If the MDT is permanently inaccessible, `lfs rm_entry {directory}` can be used to delete the directory entry for the unavailable MDT. Using `rmdir` would otherwise report an IO error due to the remote MDT being inactive. Please note that if the MDT *is* available, standard `rm -r` should be used to delete the remote directory. After the remote directory has been removed, the administrator should mark the MDT as permanently inactive with:

```
lctl conf_param {MDT name}.mdc.active=0
```

A user can identify which MDT holds a remote sub-directory using the `lfs` utility. For example:

```
client$ lfs getstripe --mdt-index /mnt/lustre/remote_dir1
1
client$ mkdir /mnt/lustre/local_dir0
client$ lfs getstripe --mdt-index /mnt/lustre/local_dir0
0
```

The `lfs getstripe --mdt-index` command returns the index of the MDT that is serving the given directory.

14.9.2. Working with Inactive MDTs

Files located on or below an inactive MDT are inaccessible until the MDT is activated again. Clients accessing an inactive MDT will receive an EIO error.

14.9.3. Removing an OST from the File System

When deactivating an OST, note that the client and MDS each have an OSC device that handles communication with the corresponding OST. To remove an OST from the file system:

1. If the OST is functional, and there are files located on the OST that need to be migrated off of the OST, the file creation for that OST should be temporarily deactivated on the MDS (each MDS if running with multiple MDS nodes in DNE mode).

Introduced in Lustre 2.9

With Lustre 2.9 and later, the MDS should be set to only disable file creation on that OST by setting `max_create_count` to zero:

```
mds# lctl set_param osp.osc_name.max_create_count=0
```

This ensures that files deleted or migrated off of the OST will have their corresponding OST objects destroyed, and the space will be freed. For example, to disable OST0000 in the filesystem `testfs`, run:

```
mds# lctl set_param osp.testfs-OST0000-osc-MDT*.max_create_count=0
```

on each MDS in the `testfs` filesystem.

- b. With older versions of Lustre, to deactivate the OSC on the MDS node(s) use:

```
mgs# lctl set_param osp.osc_name.active=0
```

This will prevent the MDS from attempting any communication with that OST, including destroying objects located thereon. This is fine if the OST will be removed permanently, if the OST is not stable in operation, or if it is in a read-only state. Otherwise, the free space and objects on the OST will not decrease when files are deleted, and object destruction will be deferred until the MDS reconnects to the OST.

For example, to deactivate OST0000 in the filesystem `testfs`, run:

```
mgs# lctl set_param osp.testfs-OST0000-osc-MDT*.active=0
```

Deactivating the OST on the *MDS* does not prevent use of existing objects for read/write by a client.

Note

If migrating files from a working OST, do not deactivate the OST on clients. This causes IO errors when accessing files located there, and migrating files on the OST would fail.

Caution

Do not use `lctl set_param -P` or `lctl conf_param` to deactivate the OST if it is still working, as this immediately and permanently deactivates it in the file system configuration on both the MDS and all clients.

2. Discover all files that have objects residing on the deactivated OST. Depending on whether the deactivated OST is available or not, the data from that OST may be migrated to other OSTs, or may need to be restored from backup.
 - a. If the OST is still online and available, find all files with objects on the deactivated OST, and copy them to other OSTs in the file system to:

```
client# lfs find --ost ost_name /mount/point | lfs_migrate -y
```

Note that if multiple OSTs are being deactivated at one time, the `lfs find` command can take multiple `--ost` arguments, and will return files that are located on *any* of the specified OSTs.

- b. If the OST is no longer available, delete the files on that OST and restore them from backup:

```
client# lfs find --ost ost_uuid -print0 /mount/point |
tee /tmp/files_to_restore | xargs -0 -n 1 unlink
```

The list of files that need to be restored from backup is stored in `/tmp/files_to_restore`. Restoring these files is beyond the scope of this document.

3. Deactivate the OST.
 - a. If there is expected to be a replacement OST in some short time (a few days), the OST can temporarily be deactivated on the clients using:

```
client# lctl set_param osc.fsname-OSTnumber-*.active=0
```

Note

This setting is only temporary and will be reset if the clients are remounted or rebooted. It needs to be run on all clients.

- b. If there is not expected to be a replacement for this OST in the near future, permanently deactivate it on all clients and the MDS by running the following command on the MGS:

```
mgs# lctl conf_param ost_name.osc.active=0
```

Note

A deactivated OST still appears in the file system configuration, though a replacement OST can be created that re-uses the same OST index with the `mkfs.lustre --replace` option, see Section 14.9.5, “Restoring OST Configuration Files”.

Introduced in Lustre 2.16

In Lustre 2.16 and later, it is possible to run the command `"lctl del_ost --target fsname-OSTxxxx"` on the MGS to totally remove an OST from the MGS configuration logs. This will cancel the configuration logs for that OST in the client and MDT configuration logs for the named filesystem. This permanently removes the configuration records for that OST from the filesystem, so that it will not be visible on later client and MDT mounts, and should only be run after earlier steps to migrate files off the OST.

If the `del_ost` command is not available, the OST configuration records should be found in the startup logs by running the command `"lctl --device MGS llog_print fsname-client"` on the MGS (and also `"... $fsname-MDTxxxx"` for all the MDTs) to list all `attach`, `setup`, `add_osc`, `add_pool`, and other records related to the removed OST(s). Once the index value is known for each configuration record, the command `"lctl --device MGS llog_cancel llog_name -i index "` will drop that record from the configuration log `llog_name`. This is needed for each of `fsname-client` and `fsname-MDTxxxx` configuration logs so that new mounts will no longer process it. If a whole OSS is being removed, the `add_uuid` records for the OSS should similarly be canceled.

```
mgs# lctl --device MGS llog_print testfs-client | egrep "192.168.10.99@tcp|OST
- { index: 135, event: add_uuid, nid: 192.168.10.99@tcp(0x20000c0a80a63), node
- { index: 136, event: attach, device: testfs-OST0003-osc, type: osc, UUID: te
- { index: 137, event: setup, device: testfs-OST0003-osc, UUID: testfs-OST0003
- { index: 138, event: add_osc, device: testfs-clilov, ost: testfs-OST0003_UUI
mgs# lctl --device MGS llog_cancel testfs-client -i 138
mgs# lctl --device MGS llog_cancel testfs-client -i 137
mgs# lctl --device MGS llog_cancel testfs-client -i 136
```

14.9.4. Backing Up OST Configuration Files

If the OST device is still accessible, then the Lustre configuration files on the OST should be backed up and saved for future use in order to avoid difficulties when a replacement OST is returned to service. These files rarely change, so they can and should be backed up while the OST is functional and accessible. If the deactivated OST is still available to mount (i.e. has not permanently failed or is unmountable due to severe corruption), an effort should be made to preserve these files.

1. Mount the OST file system.

```
oss# mkdir -p /mnt/ost
oss# mount -t ldiskfs /dev/ost_device /mnt/ost
```

2. Back up the OST configuration files.

```
oss# tar cvf ost_name.tar -C /mnt/ost last_rcvd \
    CONFIGS/ O/0/LAST_ID
```

3. Unmount the OST file system.

```
oss# umount /mnt/ost
```

14.9.5. Restoring OST Configuration Files

If the original OST is still available, it is best to follow the OST backup and restore procedure given in either Section 18.2, “Backing Up and Restoring an MDT or OST (ldiskfs Device Level)”, or Section 18.3, “Backing Up an OST or MDT (Backend File System Level)” and Section 18.4, “Restoring a File-Level Backup”.

To replace an OST that was removed from service due to corruption or hardware failure, the replacement OST needs to be formatted using `mkfs.lustre`, and the Lustre file system configuration should be restored, if available. Any objects stored on the OST will be permanently lost, and files using the OST should be deleted and/or restored from backup.

Introduced in Lustre 2.5

With Lustre 2.5 and later, it is possible to replace an OST to the same index without restoring the configuration files, using the `--replace` option at format time.

```
oss# mkfs.lustre --ost --reformat --replace --index=old_ost_index \
    other_options /dev/new_ost_dev
```

The MDS and OSS will negotiate the `LAST_ID` value for the replacement OST.

If the OST configuration files were not backed up, due to the OST file system being completely inaccessible, it is still possible to replace the failed OST with a new one at the same OST index.

1. For older versions, format the OST file system without the `--replace` option and restore the saved configuration:

```
oss# mkfs.lustre --ost --reformat --index=old_ost_index \
    other_options /dev/new_ost_dev
```

2. Mount the OST file system.

```
oss# mkdir /mnt/ost
oss# mount -t ldiskfs /dev/new_ost_dev /mnt/ost
```

3. Restore the OST configuration files, if available.

```
oss# tar xvf ost_name.tar -C /mnt/ost
```

4. Recreate the OST configuration files, if unavailable.

Follow the procedure in Section 35.3.4, “Fixing a Bad `LAST_ID` on an OST” to recreate the `LAST_ID` file for this OST index. The `last_rcvd` file will be recreated when the OST is first mounted using

the default parameters, which are normally correct for all file systems. The `CONFIGS/mountdata` file is created by `mkfs.lustre` at format time, but has flags set that request it to register itself with the MGS. It is possible to copy the flags from another working OST (which should be the same):

```
oss1# debugfs -c -R "dump CONFIGS/mountdata /tmp" /dev/other_osdev
oss1# scp /tmp/mountdata oss0:/tmp/mountdata
oss0# dd if=/tmp/mountdata of=/mnt/ost/CONFIGS/mountdata bs=4 count=1 seek=5 ski
```

5. Unmount the OST file system.

```
oss# umount /mnt/ost
```

14.9.6. Returning a Deactivated OST to Service

If the OST was permanently deactivated, it needs to be reactivated in the MGS configuration.

```
mgs# lctl conf_param ost_name.osc.active=1
```

If the OST was temporarily deactivated, it needs to be reactivated on the MDS and clients.

```
mgs# lctl set_param osp.fsname-OSTnumber-*.active=1
client# lctl set_param osc.fsname-OSTnumber-*.active=1
```

14.10. Aborting Recovery

You can abort recovery with either the `lctl` utility or by mounting the target with the `abort_recov` option (`mount -o abort_recov`). When starting a target, run:

```
mgs# mount -t lustre -L mdt_name -o abort_recov /mount_point
```

Note

The recovery process is blocked until all OSTs are available.

14.11. Determining Which Machine is Serving an OST

In the course of administering a Lustre file system, you may need to determine which machine is serving a specific OST. It is not as simple as identifying the machine's IP address, as IP is only one of several networking protocols that the Lustre software uses and, as such, LNet does not use IP addresses as node identifiers, but NIDs instead. To identify the NID that is serving a specific OST, run one of the following commands on a client (you do not need to be a root user):

```
client$ lctl get_param osc.fsname-OSTnumber*.ost_conn_uid
```

For example:

```
client$ lctl get_param osc.*-OST0000*.ost_conn_uid
osc.testfs-OST0000-osc-f1579000.ost_conn_uid=192.168.20.1@tcp
```

- OR -

```
client$ lctl get_param osc.*.ost_conn_uid
```

```
osc.testfs-OST0000-osc-f1579000.ost_conn_uuid=192.168.20.1@tcp
osc.testfs-OST0001-osc-f1579000.ost_conn_uuid=192.168.20.1@tcp
osc.testfs-OST0002-osc-f1579000.ost_conn_uuid=192.168.20.1@tcp
osc.testfs-OST0003-osc-f1579000.ost_conn_uuid=192.168.20.1@tcp
osc.testfs-OST0004-osc-f1579000.ost_conn_uuid=192.168.20.1@tcp
```

14.12. Changing the Address of a Failover Node

To change the address of a failover node (e.g, to use node X instead of node Y), run this command on the OSS/OST partition (depending on which option was used to originally identify the NID):

```
oss# tunefs.lustre --erase-params --servicenode=NID /dev/ost_device
```

or

```
oss# tunefs.lustre --erase-params --failnode=NID /dev/ost_device
```

For more information about the `--servicenode` and `--failnode` options, see Chapter 11, *Configuring Failover in a Lustre File System*.

14.13. Separate a combined MGS/MDT

These instructions assume the MGS node will be the same as the MDS node. For instructions on how to move MGS to a different node, see Section 14.5, “Changing a Server NID”.

These instructions are for doing the split without shutting down other servers and clients.

1. Stop the MDS.

Unmount the MDT

```
umount -f /dev/mdt_device
```

2. Create the MGS.

```
mgs# mkfs.lustre --mgs --device-size=size /dev/mgs_device
```

3. Copy the configuration data from MDT disk to the new MGS disk.

```
mgs# mount -t ldiskfs -o ro /dev/mdt_device /mdt_mount_point
```

```
mgs# mount -t ldiskfs -o rw /dev/mgs_device /mgs_mount_point
```

```
mgs# cp -r /mdt_mount_point/CONFIGS/filesystem_name-* /mgs_mount_point/CONFIGS/.
```

```
mgs# umount /mgs_mount_point
```

```
mgs# umount /mdt_mount_point
```

See Section 14.4, “Regenerating Lustre Configuration Logs” for alternative method.

4. Start the MGS.

```
mgs# mount -t lustre /dev/mgs_device /mgs_mount_point
```

Check to make sure it knows about all your file system

```
mgs:/root# lctl get_param mgs.MGS.filesystems
```

5. Remove the MGS option from the MDT, and set the new MGS nid.

```
mgs# tuneufs.lustre --nomgs --mgsnode=new_mgs_nid /dev/mdt-device
```

6. Start the MDT.

```
mgs# mount -t lustre /dev/mdt_device /mdt_mount_point
```

Check to make sure the MGS configuration looks right:

```
mgs# lctl get_param mgs.MGS.live.filesystem_name
```

Introduced in Lustre 2.13

14.14. Set an MDT to read-only

It is sometimes desirable to be able to mark the filesystem read-only directly on the server, rather than remounting the clients and setting the option there. This can be useful if there is a rogue client that is deleting files, or when decommissioning a system to prevent already-mounted clients from modifying it anymore.

Set the `mdt.*.readonly` parameter to 1 to immediately set the MDT to read-only. All future MDT access will immediately return a "Read-only file system" error (EROFS) until the parameter is set to 0 again.

Example of setting the `readonly` parameter to 1, verifying the current setting, accessing from a client, and setting the parameter back to 0:

```
mgs# lctl set_param mdt.fs-MDT0000.readonly=1
mdt.fs-MDT0000.readonly=1
```

```
mgs# lctl get_param mdt.fs-MDT0000.readonly
mdt.fs-MDT0000.readonly=1
```

```
client$ touch test_file
touch: cannot touch `test_file': Read-only file system
```

```
mgs# lctl set_param mdt.fs-MDT0000.readonly=0
mdt.fs-MDT0000.readonly=0
```

Introduced in Lustre 2.14

14.15. Tune Fallocate for Idiskfs

This section shows how to tune/enable/disable fallocate for Idiskfs OSTs.

The default `mode=0` is the standard "allocate unwritten extents" behavior used by ext4. This is by far the fastest for space allocation, but requires the unwritten extents to be split and/or zeroed when they are overwritten.

The OST fallocate mode=1 can also be set to use "zeroed extents", which may be handled by "WRITE SAME", "TRIM zeroes data", or other low-level functionality in the underlying block device.

mode=-1 completely disables fallocate.

Example: To completely disable fallocate

```
lctl set_param osd-ldiskfs.*.fallocate_zero_blocks=-1
```

Example: To enable fallocate to use 'zeroed extents'

```
lctl set_param osd-ldiskfs.*.fallocate_zero_blocks=1
```

Chapter 15. Managing Lustre Networking (LNet)

This chapter describes some tools for managing Lustre networking (LNet) and includes the following sections:

- Section 15.1, “Updating the Health Status of a Peer or Router”
- Section 15.2, “Starting and Stopping LNet”
- Section 15.3, “Hardware Based Multi-Rail Configurations with LNet”
- Section 15.4, “Load Balancing with an InfiniBand* Network”
- Section 15.5, “Dynamically Configuring LNet Routes”

15.1. Updating the Health Status of a Peer or Router

There are two mechanisms to update the health status of a peer or a router:

- LNet can actively check health status of all routers and mark them as dead or alive automatically. By default, this is off. To enable it set `auto_down` and if desired `check_routers_before_use`. This initial check may cause a pause equal to `router_ping_timeout` at system startup, if there are dead routers in the system.
- When there is a communication error, all LNDs notify LNet that the peer (not necessarily a router) is down. This mechanism is always on, and there is no parameter to turn it off. However, if you set the LNet module parameter `auto_down` to 0, LNet ignores all such peer-down notifications.

Several key differences in both mechanisms:

- The router pinger only checks routers for their health, while LNDs notices all dead peers, regardless of whether they are a router or not.
- The router pinger actively checks the router health by sending pings, but LNDs only notice a dead peer when there is network traffic going on.
- The router pinger can bring a router from alive to dead or vice versa, but LNDs can only bring a peer down.

15.2. Starting and Stopping LNet

The Lustre software automatically starts and stops LNet, but it can also be manually started in a standalone manner. This is particularly useful to verify that your networking setup is working correctly before you attempt to start the Lustre file system.

15.2.1. Starting LNet

To start LNet, run:

```
$ modprobe lnet
$ lctl network up
```

To see the list of local NIDs, run:

```
$ lctl list_nids
```

This command tells you the network(s) configured to work with the Lustre file system.

If the networks are not correctly setup, see the `modules.conf` "networks=" line and make sure the network layer modules are correctly installed and configured.

To get the best remote NID, run:

```
$ lctl which_nid NIDS
```

where *NIDS* is the list of available NIDs.

This command takes the "best" NID from a list of the NIDs of a remote host. The "best" NID is the one that the local node uses when trying to communicate with the remote node.

15.2.1.1. Starting Clients

To start a TCP client, run:

```
mount -t lustre mdsnode:/mdsA/client /mnt/lustre/
```

To start an Elan client, run:

```
mount -t lustre 2@elan0:/mdsA/client /mnt/lustre
```

15.2.2. Stopping LNet

Before the LNet modules can be removed, LNet references must be removed. In general, these references are removed automatically when the Lustre file system is shut down, but for standalone routers, an explicit step is needed to stop LNet. Run:

```
lctl network unconfigure
```

Note

Attempting to remove Lustre modules prior to stopping the network may result in a crash or an LNet hang. If this occurs, the node must be rebooted (in most cases). Make sure that the Lustre network and Lustre file system are stopped prior to unloading the modules. Be extremely careful using `rmmod -f`.

To unconfigure the LNet network, run:

```
modprobe -r lnd_and_lnet_modules
```

Note

To remove all Lustre modules, run:

```
$ lustre_rmmod
```

15.3. Hardware Based Multi-Rail Configurations with LNet

To aggregate bandwidth across both rails of a dual-rail IB cluster (o2iblnd) ¹ using LNet, consider these points:

- LNet can work with multiple rails, however, it does not load balance across them. The actual rail used for any communication is determined by the peer NID.
- Hardware multi-rail LNet configurations do not provide an additional level of network fault tolerance. The configurations described below are for bandwidth aggregation only.
- A Lustre node always uses the same local NID to communicate with a given peer NID. The criteria used to determine the local NID are:

Introduced in Lustre 2.5

Lowest route priority number (lower number, higher priority).

- Fewest hops (to minimize routing), and
- Appears first in the "networks" or "ip2nets" LNet configuration strings

15.4. Load Balancing with an InfiniBand^{*} Network

A Lustre file system contains OSSs with two InfiniBand HCAs. Lustre clients have only one InfiniBand HCA using OFED-based Infiniband "o2ib" drivers. Load balancing between the HCAs on the OSS is accomplished through LNet.

15.4.1. Setting Up `lustre.conf` for Load Balancing

To configure LNet for load balancing on clients and servers:

1. Set the `lustre.conf` options.

Depending on your configuration, set `lustre.conf` options as follows:

- Dual HCA OSS server

```
options lnet networks="o2ib0(ib0),o2ib1(ib1)"
```

- Client with the odd IP address

```
options lnet ip2nets="o2ib0(ib0) 192.168.10.[103-253/2]"
```

- Client with the even IP address

```
options lnet ip2nets="o2ib1(ib0) 192.168.10.[102-254/2]"
```

2. Run the `modprobe lnet` command and create a combined MGS/MDT file system.

¹Hardware multi-rail configurations are only supported by o2iblnd; other IB LNDs do not support multiple interfaces.

The following commands create an MGS/MDT or OST file system and mount the targets on the servers.

```
modprobe lnet
# mkfs.lustre --fsname lustre --mgs --mdt /dev/mdt_device
# mkdir -p /mount_point
# mount -t lustre /dev/mdt_device /mount_point
```

For example:

```
modprobe lnet
mds# mkfs.lustre --fsname lustre --mdt --mgs /dev/sda
mds# mkdir -p /mnt/test/mdt
mds# mount -t lustre /dev/sda /mnt/test/mdt
mds# mount -t lustre mgs@o2ib0:/lustre /mnt/mdt
oss# mkfs.lustre --fsname lustre --mgsnode=mds@o2ib0 --ost --index=0 /dev/sda
oss# mkdir -p /mnt/test/mdt
oss# mount -t lustre /dev/sda /mnt/test/ost
oss# mount -t lustre mgs@o2ib0:/lustre /mnt/ost0
```

3. Mount the clients.

```
client# mount -t lustre mgs_node:/fsname /mount_point
```

This example shows an IB client being mounted.

```
client# mount -t lustre
192.168.10.101@o2ib0,192.168.10.102@o2ib1:/mds/client /mnt/lustre
```

As an example, consider a two-rail IB cluster running the OFED stack with these IPoIB address assignments.

	ib0	ib1
Servers	192.168.0.*	192.168.1.*
Clients	192.168.[2-127].*	192.168.[128-253].*

You could create these configurations:

- A cluster with more clients than servers. The fact that an individual client cannot get two rails of bandwidth is unimportant because the servers are typically the actual bottleneck.

```
ip2nets="o2ib0(ib0),      o2ib1(ib1)      192.168.[0-1].*          \
                                     #all servers;\
                                     o2ib0(ib0)      192.168.[2-253].[0-252/2]      #even cli\
ients;\
                                     o2ib1(ib1)      192.168.[2-253].[1-253/2]      #odd cli\
ents"
```

This configuration gives every server two NIDs, one on each network, and statically load-balances clients between the rails.

- A single client that must get two rails of bandwidth, and it does not matter if the maximum aggregate bandwidth is only (# servers) * (1 rail).

```
ip2nets="      o2ib0(ib0)          192.168.[0-1].[0-252/2]          \
                                     #even servers;\
```

```

o2ib1(ib1)                192.168.[0-1].[1-253/2] \
                           #odd servers;\
o2ib0(ib0),o2ib1(ib1)    192.168.[2-253].* \
                           #clients"
    
```

This configuration gives every server a single NID on one rail or the other. Clients have a NID on both rails.

- All clients and all servers must get two rails of bandwidth.

```

ip2nets=â€  o2ib0(ib0),o2ib2(ib1)    192.168.[0-1].[0-252/2] \
             #even servers;\
             o2ib1(ib0),o2ib3(ib1)    192.168.[0-1].[1-253/2] \
#odd servers;\
             o2ib0(ib0),o2ib3(ib1)    192.168.[2-253].[0-252/2] \
#even clients;\
             o2ib1(ib0),o2ib2(ib1)    192.168.[2-253].[1-253/2] \
#odd clients"
    
```

This configuration includes two additional proxy o2ib networks to work around the simplistic NID selection algorithm in the Lustre software. It connects "even" clients to "even" servers with o2ib0 on rail0, and "odd" servers with o2ib3 on rail1. Similarly, it connects "odd" clients to "odd" servers with o2ib1 on rail0, and "even" servers with o2ib2 on rail1.

15.5. Dynamically Configuring LNet Routes

Two scripts are provided: `lustre/scripts/lustre_routes_config` and `lustre/scripts/lustre_routes_conversion`.

`lustre_routes_config` sets or cleans up LNet routes from the specified config file. The `/etc/sysconfig/lnet_routes.conf` file can be used to automatically configure routes on LNet startup.

`lustre_routes_conversion` converts a legacy routes configuration file to the new syntax, which is parsed by `lustre_routes_config`.

15.5.1. `lustre_routes_config`

`lustre_routes_config` usage is as follows

```

lustre_routes_config [--setup|--cleanup|--dry-run|--verbose] config_file
    --setup: configure routes listed in config_file
    --cleanup: unconfigure routes listed in config_file
    --dry-run: echo commands to be run, but do not execute them
    --verbose: echo commands before they are executed
    
```

The format of the file which is passed into the script is as follows:

```

network: { gateway: gateway@exit_network [hop: hop] [priority:
priority] }
    
```

An LNet router is identified when its local NID appears within the list of routes. However, this can not be achieved by the use of this script, since the script only adds extra routes after the router is identified. To ensure that a router is identified correctly, make sure to add its local NID in the routes parameter in the `modprobe lustre` configuration file. See Section 43.1, "Introduction".

15.5.2. lustre_routes_conversion

lustre_routes_conversion usage is as follows:

```
lustre_routes_conversion legacy_file new_file
```

lustre_routes_conversion takes as a first parameter a file with routes configured as follows:

```
network [hop] gateway@exit network[:priority];
```

The script then converts each routes entry in the provided file to:

```
network: { gateway: gateway@exit network [hop: hop] [priority:
priority] }
```

and appends each converted entry to the output file passed in as the second parameter to the script.

15.5.3. Route Configuration Examples

Below is an example of a legacy LNet route configuration. A legacy configuration file can have multiple entries.

```
tcp1 10.1.1.2@tcp0:1;
tcp2 10.1.1.3@tcp0:2;
tcp3 10.1.1.4@tcp0;
```

Below is an example of the converted LNet route configuration. The following would be the result of the `lustre_routes_conversion` script, when run on the above legacy entries.

```
tcp1: { gateway: 10.1.1.2@tcp0 priority: 1 }
tcp2: { gateway: 10.1.1.2@tcp0 priority: 2 }
tcp1: { gateway: 10.1.1.4@tcp0 }
```

Chapter 16. LNet Software Multi-Rail

This chapter describes LNet Software Multi-Rail configuration and administration.

- Section 16.1, “Multi-Rail Overview”
 - Section 16.2, “Configuring Multi-Rail”
 - Section 16.3, “Notes on routing with Multi-Rail”
 - Section 16.4, “Multi-Rail Routing with LNet Health”
 - Section 16.5, “LNet Health”

16.1. Multi-Rail Overview

In computer networking, multi-rail is an arrangement in which two or more network interfaces to a single network on a computer node are employed, to achieve increased throughput. Multi-rail can also be where a node has one or more interfaces to multiple, even different kinds of networks, such as Ethernet, Infiniband, and Intel® Omni-Path. For Lustre clients, multi-rail generally presents the combined network capabilities as a single LNet network. Peer nodes that are multi-rail capable are established during configuration, as are user-defined interface-section policies.

The following link contains a detailed high-level design for the feature: Multi-Rail High-Level Design [https://wiki.lustre.org/images/b/bb/Multi-Rail_High-Level_Design_20150119.pdf]

16.2. Configuring Multi-Rail

Every node using multi-rail networking needs to be properly configured. Multi-rail uses `lnetctl` and the LNet Configuration Library for configuration. Configuring multi-rail for a given node involves two tasks:

1. Configuring multiple network interfaces present on the local node.
2. Adding remote peers that are multi-rail capable (are connected to one or more common networks with at least two interfaces).

This section is a supplement to Section 9.1.3, “Adding, Deleting and Showing Networks” and contains further examples for Multi-Rail configurations.

For information on the dynamic peer discovery feature added in Lustre Release 2.11.0, see Section 9.1.5, “Dynamic Peer Discovery”.

16.2.1. Configure Multiple Interfaces on the Local Node

Example `lnetctl add` command with multiple interfaces in a Multi-Rail configuration:

```
lnetctl net add --net tcp --if eth0,eth1
```

Example of YAML net show:

```
lnetctl net show -v
net:
  - net type: lo
    local NI(s):
      - nid: 0@lo
        status: up
        statistics:
          send_count: 0
          recv_count: 0
          drop_count: 0
        tunables:
          peer_timeout: 0
          peer_credits: 0
          peer_buffer_credits: 0
          credits: 0
        lnd tunables:
          tcp bonding: 0
          dev cpt: 0
          CPT: "[0]"
  - net type: tcp
    local NI(s):
      - nid: 192.168.122.10@tcp
        status: up
        interfaces:
          0: eth0
        statistics:
          send_count: 0
          recv_count: 0
          drop_count: 0
        tunables:
          peer_timeout: 180
          peer_credits: 8
          peer_buffer_credits: 0
          credits: 256
        lnd tunables:
          tcp bonding: 0
          dev cpt: -1
          CPT: "[0]"
      - nid: 192.168.122.11@tcp
        status: up
        interfaces:
          0: eth1
        statistics:
          send_count: 0
          recv_count: 0
          drop_count: 0
        tunables:
          peer_timeout: 180
          peer_credits: 8
          peer_buffer_credits: 0
```

```

        credits: 256
    lnd tunables:
    tcp bonding: 0
    dev cpt: -1
    CPT: "[0]"

```

16.2.2. Deleting Network Interfaces

Example delete with `lnetctl net del`:

Assuming the network configuration is as shown above with the `lnetctl net show -v` in the previous section, we can delete a net with following command:

```
lnetctl net del --net tcp --if eth0
```

The resultant net information would look like:

```

lnetctl net show -v
net:
  - net type: lo
    local NI(s):
      - nid: 0@lo
        status: up
        statistics:
          send_count: 0
          rcv_count: 0
          drop_count: 0
        tunables:
          peer_timeout: 0
          peer_credits: 0
          peer_buffer_credits: 0
          credits: 0
        lnd tunables:
          tcp bonding: 0
          dev cpt: 0
          CPT: "[0,1,2,3]"

```

The syntax of a YAML file to perform a delete would be:

```

- net type: tcp
  local NI(s):
    - nid: 192.168.122.10@tcp
    interfaces:
      0: eth0

```

16.2.3. Adding Remote Peers that are Multi-Rail Capable

The following example `lnetctl peer add` command adds a peer with 2 nids, with `192.168.122.30@tcp` being the primary nid:

```
lnetctl peer add --prim_nid 192.168.122.30@tcp --nid 192.168.122.30@tcp,19
```

The resulting `lnetctl peer show` would be:

```
lnetctl peer show -v
peer:
- primary nid: 192.168.122.30@tcp
  Multi-Rail: True
  peer ni:
  - nid: 192.168.122.30@tcp
    state: NA
    max_ni_tx_credits: 8
    available_tx_credits: 8
    min_tx_credits: 7
    tx_q_num_of_buf: 0
    available_rtr_credits: 8
    min_rtr_credits: 8
    refcount: 1
    statistics:
      send_count: 2
      rcv_count: 2
      drop_count: 0
  - nid: 192.168.122.31@tcp
    state: NA
    max_ni_tx_credits: 8
    available_tx_credits: 8
    min_tx_credits: 7
    tx_q_num_of_buf: 0
    available_rtr_credits: 8
    min_rtr_credits: 8
    refcount: 1
    statistics:
      send_count: 1
      rcv_count: 1
      drop_count: 0
```

The following is an example YAML file for adding a peer:

```
addPeer.yaml
peer:
- primary nid: 192.168.122.30@tcp
  Multi-Rail: True
  peer ni:
  - nid: 192.168.122.31@tcp
```

16.2.4. Deleting Remote Peers

Example of deleting a single nid of a peer (192.168.122.31@tcp):

```
lnetctl peer del --prim_nid 192.168.122.30@tcp --nid 192.168.122.31@tcp
```

Example of deleting the entire peer:

```
lnetctl peer del --prim_nid 192.168.122.30@tcp
```

Example of deleting a peer via YAML:

Assuming the following peer configuration:

```
peer:
  - primary nid: 192.168.122.30@tcp
    Multi-Rail: True
  peer ni:
    - nid: 192.168.122.30@tcp
      state: NA
    - nid: 192.168.122.31@tcp
      state: NA
    - nid: 192.168.122.32@tcp
      state: NA
```

You can delete 192.168.122.32@tcp as follows:

```
delPeer.yaml
peer:
  - primary nid: 192.168.122.30@tcp
    Multi-Rail: True
  peer ni:
    - nid: 192.168.122.32@tcp
```

```
% lnetctl import --del < delPeer.yaml
```

16.3. Notes on routing with Multi-Rail

This section details how to configure Multi-Rail with the routing feature before the Section 16.4, “Multi-Rail Routing with LNet Health” feature landed in Lustre 2.13. Routing code has always monitored the state of the route, in order to avoid using unavailable ones.

This section describes how you can configure multiple interfaces on the same gateway node but as different routes. This uses the existing route monitoring algorithm to guard against interfaces going down. With the Section 16.4, “Multi-Rail Routing with LNet Health” feature introduced in Lustre 2.13, the new algorithm uses the Section 16.5, “LNet Health” feature to monitor the different interfaces of the gateway and always ensures that the healthiest interface is used. Therefore, the configuration described in this section applies to releases prior to Lustre 2.13. It will still work in 2.13 as well, however it is not required due to the reason mentioned above.

16.3.1. Multi-Rail Cluster Example

The below example outlines a simple system where all the Lustre nodes are MR capable. Each node in the cluster has two interfaces.

Figure 16.1. Routing Configuration with Multi-Rail

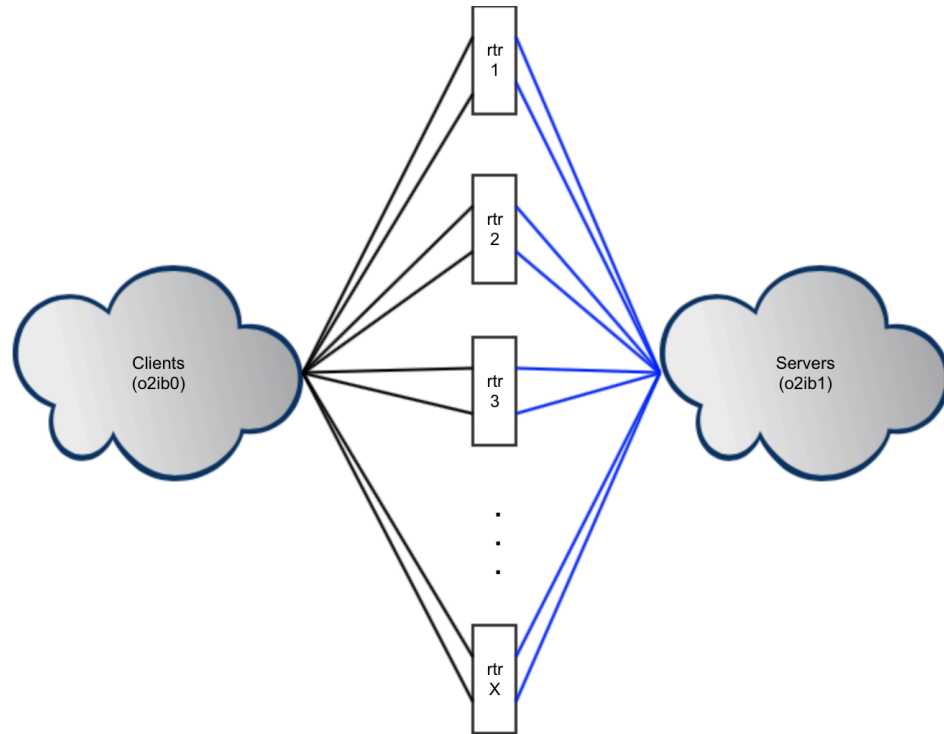

The routers can aggregate the interfaces on each side of the network by configuring them on the appropriate network.

An example configuration:

Routers

```
lnetctl net add --net o2ib0 --if ib0,ib1
lnetctl net add --net o2ib1 --if ib2,ib3
lnetctl peer add --nid <peer1-nidA>@o2ib,<peer1-nidB>@o2ib,...
lnetctl peer add --nid <peer2-nidA>@o2ib1,<peer2-nidB>@o2ib1,...
lnetctl set routing 1
```

Clients

```
lnetctl net add --net o2ib0 --if ib0,ib1
lnetctl route add --net o2ib1 --gateway <rtrX-nidA>@o2ib
lnetctl peer add --nid <rtrX-nidA>@o2ib,<rtrX-nidB>@o2ib
```

Servers

```
lnetctl net add --net o2ib1 --if ib0,ib1
lnetctl route add --net o2ib0 --gateway <rtrX-nidA>@o2ib1
lnetctl peer add --nid <rtrX-nidA>@o2ib1,<rtrX-nidB>@o2ib1
```

In the above configuration the clients and the servers are configured with only one route entry per router. This works because the routers are MR capable. By adding the routers as peers with multiple interfaces to the clients and the servers, when sending to the router the MR algorithm will ensure that both interfaces of the routers are used.

However, as of the Lustre 2.10 release LNet Resiliency is still under development and single interface failure will still cause the entire router to go down.

16.3.2. Utilizing Router Resiliency

Currently, LNet provides a mechanism to monitor each route entry. LNet pings each gateway identified in the route entry on regular, configurable interval to ensure that it is alive. If sending over a specific route fails or if the router pinger determines that the gateway is down, then the route is marked as down and is not used. It is subsequently pinged on regular, configurable intervals to determine when it becomes alive again.

This mechanism can be combined with the MR feature in Lustre 2.10 to add this router resiliency feature to the configuration.

Routers

```
lnetctl net add --net o2ib0 --if ib0,ib1
lnetctl net add --net o2ib1 --if ib2,ib3
lnetctl peer add --nid <peer1-nidA>@o2ib,<peer1-nidB>@o2ib,...
lnetctl peer add --nid <peer2-nidA>@o2ib1,<peer2-nidB>@o2ib1,...
lnetctl set routing 1
```

Clients

```
lnetctl net add --net o2ib0 --if ib0,ib1
lnetctl route add --net o2ib1 --gateway <rtrX-nidA>@o2ib
lnetctl route add --net o2ib1 --gateway <rtrX-nidB>@o2ib
```

Servers

```
lnetctl net add --net o2ib1 --if ib0,ib1
lnetctl route add --net o2ib0 --gateway <rtrX-nidA>@o2ib1
lnetctl route add --net o2ib0 --gateway <rtrX-nidB>@o2ib1
```

There are a few things to note in the above configuration:

1. The clients and the servers are now configured with two routes, each route's gateway is one of the interfaces of the route. The clients and servers will view each interface of the same router as a separate gateway and will monitor them as described above.
2. The clients and the servers are not configured to view the routers as MR capable. This is important because we want to deal with each interface as a separate peers and not different interfaces of the same peer.
3. The routers are configured to view the peers as MR capable. This is an oddity in the configuration, but is currently required in order to allow the routers to load balance the traffic load across its interfaces evenly.

16.3.3. Mixed Multi-Rail/Non-Multi-Rail Cluster

The above principles can be applied to mixed MR/Non-MR cluster. For example, the same configuration shown above can be applied if the clients and the servers are non-MR while the routers are MR capable. This appears to be a common cluster upgrade scenario.

Introduced in Lustre 2.13

16.4. Multi-Rail Routing with LNet Health

This section details how routing and pertinent module parameters can be configured beginning with Lustre 2.13.

Multi-Rail with Dynamic Discovery allows LNet to discover and use all configured interfaces of a node. It references a node via its primary NID. Multi-Rail routing carries forward this concept to the routing infrastructure. The following changes are brought in with the Lustre 2.13 release:

1. Configuring a different route per gateway interface is no longer needed. One route per gateway should be configured. Gateway interfaces are used according to the Multi-Rail selection criteria.
2. Routing now relies on Section 16.5, “LNet Health” to keep track of the route aliveness.
3. Router interfaces are monitored via LNet Health. If an interface fails other interfaces will be used.
4. Routing uses LNet discovery to discover gateways on regular intervals.
5. A gateway pushes its list of interfaces upon the discovery of any changes in its interfaces' state.

16.4.1. Configuration

16.4.1.1. Configuring Routes

A gateway can have multiple interfaces on the same or different networks. The peers using the gateway can reach it on one or more of its interfaces. Multi-Rail routing takes care of managing which interface to use.

```
lnetctl route add --net <remote network>
                --gateway <NID for the gateway>
                --hop <number of hops> --priority <route priority>
```

16.4.1.2. Configuring Module Parameters

Table 16.1. Configuring Module Parameters

Module Parameter	Usage
check_routers_before	Defaults to 0. If set to 1 all routers must be up before the system can proceed.
avoid_asym_router_fail	Defaults to 1. If set to 1 single-hop routes have an additional requirement to be considered up. The requirement is that the gateway of the route must have at least one healthy network interface connected directly to the remote net of the route. In this context single-hop routes are routes that are given hop=1 explicitly when created, or routes for which lnet can infer that they have only one hop. Otherwise the route is not single-hop and this parameter has no effect.

Module Parameter	Usage
alive_router_check_interval	Defaults to 60 seconds. The gateways will be discovered every alive_router_check_interval. If the gateway can be reached on multiple networks, the interval per network is alive_router_check_interval / number of networks.
router_ping_timeout	Defaults to 50 seconds. A gateway sets its interface down if it has not received any traffic for router_ping_timeout + alive_router_check_interval
router_sensitivity_percent	Defaults to 100. This parameter defines how sensitive a gateway interface is to failure. If set to 100 then any gateway interface failure will contribute to all routes using it going down. The lower the value the more tolerant to failures the system becomes.

16.4.2. Router Health

The routing infrastructure now relies on LNet Health to keep track of interface health. Each gateway interface has a health value associated with it. If a send fails to one of these interfaces, then the interface's health value is decremented and placed on a recovery queue. The unhealthy interface is then pinged every lnet_recovery_interval. This value defaults to 1 second.

If the peer receives a message from the gateway, then it immediately assumes that the gateway's interface is up and resets its health value to maximum. This is needed to ensure we start using the gateways immediately instead of holding off until the interface is back to full health.

16.4.3. Discovery

LNet Discovery is used in place of pinging the peers. This serves two purposes:

1. The discovery communication infrastructure does not need to be duplicated for the routing feature.
2. It allows propagation of the gateway's interface state changes to the peers using the gateway.

For (2), if an interface changes state from UP to DOWN or vice versa, then a discovery PUSH is sent to all the peers which can be reached. This allows peers to adapt to changes quicker.

Discovery is designed to be backwards compatible. The discovery protocol is composed of a GET and a PUT. The GET requests interface information from the peer, this is a basic lnet ping. The peer responds with its interface information and a feature bit. If the peer is multi-rail capable and discovery is turned on, then the node will PUSH its interface information. As a result both peers will be aware of each other's interfaces.

This information is then used by the peers to decide, based on the interface state provided by the gateway, whether the route is alive or not.

16.4.4. Route Aliveness Criteria

A route is considered alive if the following conditions hold:

1. The gateway can be reached on the local net via at least one path.

2. For a single-hop route, if `avoid_asym_router_failure` is enabled then the remote network defined in the route must have at least one healthy interface on the gateway.

Introduced in Lustre 2.12

16.5. LNet Health

LNet Multi-Rail has implemented the ability for multiple interfaces to be used on the same LNet network or across multiple LNet networks. The LNet Health feature adds the ability to maintain a health value for each local and remote interface. This allows the Multi-Rail algorithm to consider the health of the interface before selecting it for sending. The feature also adds the ability to resend messages across different interfaces when interface or network failures are detected. This allows LNet to mitigate communication failures before passing the failures to upper layers for further error handling. To accomplish this, LNet Health monitors the status of the send and receive operations and uses this status to increment the interface's health value in case of success and decrement it in case of failure.

16.5.1. Health Value

The initial health value of a local or remote interface is set to `LNET_MAX_HEALTH_VALUE`, currently set to be 1000. The value itself is arbitrary and is meant to allow for health granularity, as opposed to having a simple boolean state. The granularity allows the Multi-Rail algorithm to select the interface that has the highest likelihood of sending or receiving a message.

16.5.2. Failure Types and Behavior

LNet health behavior depends on the type of failure detected:

Failure Type	Behavior
<code>localresend</code>	A local failure has occurred, such as no route found or an address resolution error. These failures could be temporary, therefore LNet will attempt to resend the message. LNet will decrement the health value of the local interface and will select it less often if there are multiple available interfaces.
<code>localno-resend</code>	A local non-recoverable error occurred in the system, such as out of memory error. In these cases LNet will not attempt to resend the message. LNet will decrement the health value of the local interface and will select it less often if there are multiple available interfaces.
<code>remoteno-resend</code>	If LNet successfully sends a message, but the message does not complete or an expected reply is not received, then it is classified as a remote error. LNet will not attempt to resend the message to avoid duplicate messages on the remote end. LNet will decrement the health value of the remote interface and

Failure Type	Behavior
	will select it less often if there are multiple available interfaces.
remoteresend	There are a set of failures where we can be reasonably sure that the message was dropped before getting to the remote end. In this case, LNet will attempt to resend the message. LNet will decrement the health value of the remote interface and will select it less often if there are multiple available interfaces.

16.5.3. User Interface

LNet Health is turned on by default. There are multiple module parameters available to control the LNet Health feature.

All the module parameters are implemented in sysfs and are located in /sys/module/lnet/parameters/. They can be set directly by echoing a value into them as well as from lnetctl.

Parameter	Description
lnet_health_sensitivity	<p>When LNet detects a failure on a particular interface it will decrement its Health Value by <code>lnet_health_sensitivity</code>. The greater the value, the longer it takes for that interface to become healthy again. The default value of <code>lnet_health_sensitivity</code> is set to 100. To disable LNet health, the value can be set to 0.</p> <p>An <code>lnet_health_sensitivity</code> of 100 means that 10 consecutive message failures or a steady-state failure rate over 1% would degrade the interface Health Value until it is disabled, while a lower failure rate would steer traffic away from the interface but it would continue to be available. When a failure occurs on an interface then its Health Value is decremented and the interface is flagged for recovery.</p> <pre>lnetctl set health_sensitivity: sensitivity 0 - turn off health evaluation >0 - sensitivity value not more than</pre>
lnet_recovery_interval	<p>When LNet detects a failure on a local or remote interface it will place that interface on a recovery queue. There is a recovery queue for local interfaces and another for remote interfaces. The interfaces on the recovery queues will be LNet PINGed every <code>lnet_recovery_interval</code>. This value defaults to 1 second. On every successful PING the health value of the interface pinged will be incremented by 1.</p>

Parameter	Description
	<p>Having this value configurable allows system administrators to control the amount of control traffic on the network.</p> <pre>lnetctl set recovery_interval: >0 - timeout in seconds</pre>
lnet_transaction_timeout	<p>This timeout is somewhat of an overloaded value. It carries the following functionality:</p> <ul style="list-style-type: none"> • A message is abandoned if it is not sent successfully when the lnet_transaction_timeout expires and the retry_count is not reached. • A GET or a PUT which expects an ACK expires if a REPLY or an ACK respectively, is not received within the lnet_transaction_timeout. <p>This value defaults to 30 seconds.</p> <pre>lnetctl set transaction_timeout: >0 - timeout in seconds</pre> <p>Note</p> <p>The LND timeout will now be a fraction of the lnet_transaction_timeout as described in the next section.</p> <p>This means that in networks where very large delays are expected then it will be necessary to increase this value accordingly.</p>
lnet_retry_count	<p>When LNet detects a failure which it deems appropriate for re-sending a message it will check if a message has passed the maximum retry_count specified. After which if a message wasn't sent successfully a failure event will be passed up to the layer which initiated message sending. The default value is 2.</p> <p>Since the message retry interval (lnet_lnd_timeout) is computed from $\text{lnet_transaction_timeout} / \text{lnet_retry_count}$, the lnet_retry_count should be kept low enough that the retry interval is not shorter than the round-trip message delay in the network. A lnet_retry_count</p>

interval to

Message/Re

Parameter	Description
	<p>of 5 is reasonable for the default <code>lnet_transaction_timeout</code> of 50 seconds.</p> <pre>lnetctl set retry_count: number of retries 0 - turn off retries >0 - number of retries, cannot be more</pre>
<p><code>lnet_lnd_timeout</code></p>	<p>This is not a configurable parameter. But it is derived from two configurable parameters: <code>lnet_transaction_timeout</code> and <code>retry_count</code>.</p> <pre>lnet_lnd_timeout = (lnet_transaction_timeout</pre> <p>As such there is a restriction that <code>lnet_transaction_timeout</code> \geq <code>retry_count</code></p> <p>The core assumption here is that in a healthy network, sending and receiving LNet messages should not have large delays. There could be large delays with RPC messages and their responses, but that's handled at the PtRPC layer.</p>

16.5.4. Displaying Information

16.5.4.1. Showing LNet Health Configuration Settings

`lnetctl` can be used to show all the LNet health configuration settings using the `lnetctl global show` command.

```
#> lnetctl global show
global:
  numa_range: 0
  max_intf: 200
  discovery: 1
  retry_count: 3
  transaction_timeout: 10
  health_sensitivity: 100
  recovery_interval: 1
```

16.5.4.2. Showing LNet Health Statistics

LNet Health statistics are shown under a higher verbosity settings. To show the local interface health statistics:

```
lnetctl net show -v 3
```

To show the remote interface health statistics:

```
lnetctl peer show -v 3
```

Sample output:

```
#> lnetctl net show -v 3
net:
- net type: tcp
  local NI(s):
  - nid: 192.168.122.108@tcp
    status: up
    interfaces:
      0: eth2
    statistics:
      send_count: 304
      rcv_count: 284
      drop_count: 0
    sent_stats:
      put: 176
      get: 138
      reply: 0
      ack: 0
      hello: 0
    received_stats:
      put: 145
      get: 137
      reply: 0
      ack: 2
      hello: 0
    dropped_stats:
      put: 10
      get: 0
      reply: 0
      ack: 0
      hello: 0
    health stats:
      health value: 1000
      interrupts: 0
      dropped: 10
      aborted: 0
      no route: 0
      timeouts: 0
      error: 0
    tunables:
      peer_timeout: 180
      peer_credits: 8
      peer_buffer_credits: 0
      credits: 256
  dev cpt: -1
  tcp bonding: 0
  CPT: "[0]"
CPT: "[0]"
```

There is a new YAML block, `health stats`, which displays the health statistics for each local or remote network interface.

Global statistics also dump the global health statistics as shown below:

```
#> lnetctl stats show
statistics:
  msgs_alloc: 0
  msgs_max: 33
  rst_alloc: 0
  errors: 0
  send_count: 901
  resend_count: 4
  response_timeout_count: 0
  local_interrupt_count: 0
  local_dropped_count: 10
  local_aborted_count: 0
  local_no_route_count: 0
  local_timeout_count: 0
  local_error_count: 0
  remote_dropped_count: 0
  remote_error_count: 0
  remote_timeout_count: 0
  network_timeout_count: 0
  rcv_count: 851
  route_count: 0
  drop_count: 10
  send_length: 425791628
  rcv_length: 69852
  route_length: 0
  drop_length: 0
```

16.5.5. Initial Settings Recommendations

LNet Health is off by default. This means that `lnet_health_sensitivity` and `lnet_retry_count` are set to 0.

Setting `lnet_health_sensitivity` to 0 will not decrement the health of the interface on failure and will not change the interface selection behavior. Furthermore, the failed interfaces will not be placed on the recovery queues. In essence, turning off the LNet Health feature.

The LNet Health settings will need to be tuned for each cluster. However, the base configuration would be as follows:

```
#> lnetctl global show
global:
  numa_range: 0
  max_intf: 200
  discovery: 1
  retry_count: 3
  transaction_timeout: 10
  health_sensitivity: 100
  recovery_interval: 1
```

This setting will allow a maximum of two retries for failed messages within the 5 second transaction timeout.

If there is a failure on the interface the health value will be decremented by 1 and the interface will be LNet PINGed every 1 second.

Chapter 17. Upgrading a Lustre File System

This chapter describes interoperability between Lustre software releases. It also provides procedures for upgrading from older Lustre 2.x software releases to a more recent 2.y Lustre release a (major release upgrade), and from a Lustre software release 2.x.y to a more recent Lustre software release 2.x.z (minor release upgrade). It includes the following sections:

- Section 17.1, “Release Interoperability and Upgrade Requirements”
- Section 17.2, “Upgrading to Lustre Software Release 2.x (Major Release)”
- Section 17.3, “Upgrading to Lustre Software Release 2.x.y (Minor Release)”

17.1. Release Interoperability and Upgrade Requirements

Lustre software release 2.x (major) upgrade:

- All servers must be upgraded at the same time, while some or all clients may be upgraded independently of the servers.
- All servers must be be upgraded to a Linux kernel supported by the Lustre software. See the Lustre Release Notes for your Lustre version for a list of tested Linux distributions.
- Clients to be upgraded must be running a compatible Linux distribution as described in the Release Notes.

Lustre software release 2.x.y release (minor) upgrade:

- All servers must be upgraded at the same time, while some or all clients may be upgraded.
- Rolling upgrades are supported for minor releases allowing individual servers and clients to be upgraded without stopping the Lustre file system.

17.2. Upgrading to Lustre Software Release 2.x (Major Release)

The procedure for upgrading from a Lustre software release 2.x to a more recent 2.y major release of the Lustre software is described in this section. To upgrade an existing 2.x installation to a more recent major release, complete the following steps:

1. Create a complete, restorable file system backup.

Caution

Before installing the Lustre software, back up ALL data. The Lustre software contains kernel modifications that interact with storage devices and may introduce security issues and data

loss if not installed, configured, or administered properly. If a full backup of the file system is not practical, a device-level backup of the MDT file system is recommended. See Chapter 18, *Backing Up and Restoring a File System* for a procedure.

2. Shut down the entire filesystem by following Section 13.4, “Stopping the Filesystem”
3. Upgrade the Linux operating system on all servers to a compatible (tested) Linux distribution and reboot.
4. Upgrade the Linux operating system on all clients to a compatible (tested) distribution and reboot.
5. Download the Lustre server RPMs for your platform from the Lustre Releases [<https://wiki.whamcloud.com/display/PUB/Lustre+Releases>] repository. See Table 8.1, “Packages Installed on Lustre Servers” for a list of required packages.
6. Install the Lustre server packages on all Lustre servers (MGS, MDSs, and OSSs).
 - a. Log onto a Lustre server as the `root` user
 - b. Use the `yum` command to install the packages:

```
# yum --nogpgcheck install pkg1.rpm pkg2.rpm ...
```
 - c. Verify the packages are installed correctly:

```
rpm -qa | egrep "lustre|wc"
```
 - d. Repeat these steps on each Lustre server.
7. Download the Lustre client RPMs for your platform from the Lustre Releases [<https://wiki.whamcloud.com/display/PUB/Lustre+Releases>] repository. See Table 8.2, “Packages Installed on Lustre Clients” for a list of required packages.

Note

The version of the kernel running on a Lustre client must be the same as the version of the `lustre-client-modules-ver` package being installed. If not, a compatible kernel must be installed on the client before the Lustre client packages are installed.

8. Install the Lustre client packages on each of the Lustre clients to be upgraded.
 - a. Log onto a Lustre client as the `root` user.
 - b. Use the `yum` command to install the packages:

```
# yum --nogpgcheck install pkg1.rpm pkg2.rpm ...
```
 - c. Verify the packages were installed correctly:

```
# rpm -qa | egrep "lustre|kernel"
```
 - d. Repeat these steps on each Lustre client.
 9. The DNE feature allows using multiple MDTs within a single filesystem namespace, and each MDT can each serve one or more remote sub-directories in the file system. The `root` directory is always located on MDT0.
-

Note that clients running a release prior to the Lustre software release 2.4 can only see the namespace hosted by MDT0 and will return an IO error if an attempt is made to access a directory on another MDT.

(Optional) To format an additional MDT, complete these steps:

- a. Determine the index used for the first MDT (each MDT must have unique index). Enter:

```
client$ lctl dl | grep mdc
36 UP mdc lustre-MDT0000-mdc-ffff88004edf3c00
      4c8be054-144f-9359-b063-8477566eb84e 5
```

In this example, the next available index is 1.

- b. Format the new block device as a new MDT at the next available MDT index by entering (on one line):

```
mds# mkfs.lustre --reformat --fsname=filesystem_name --mdt \  
      --mgsnode=mgsnode --index new_mdt_index \  
      /dev/mdt1_device
```

- 10.(Optional) If you are upgrading from a release before Lustre 2.10, to enable the project quota feature enter the following on every ldiskfs backend target while unmounted:

```
tune2fs -O project /dev/dev
```

Note

Enabling the `project` feature will prevent the filesystem from being used by older versions of `ldiskfs`, so it should only be enabled if the project quota feature is required and/or after it is known that the upgraded release does not need to be downgraded.

11. When setting up the file system, enter:

```
conf_param $FSNAME.quota.mdt=$QUOTA_TYPE
conf_param $FSNAME.quota.ost=$QUOTA_TYPE
```

Introduced in Lustre 2.13

(Optional) If upgrading an `ldiskfs` MDT formatted prior to Lustre 2.13, the "wide striping" feature that allows files to have more than 160 stripes and store other large xattrs was not enabled by default. This feature can be enabled on existing MDTs by running the following command on all MDT devices:

```
mds# tune2fs -O ea_inode /dev/mdtdev
```

For more information about wide striping, see Section 19.9, "Lustre Striping Internals".

13. Start the Lustre file system by starting the components in the order shown in the following steps:

- a. Mount the MGT. On the MGS, run

```
mgs# mount -a -t lustre
```

- b. Mount the MDT(s). On each MDT, run:

```
mds# mount -a -t lustre
```

- c. Mount all the OSTs. On each OSS node, run:

```
oss# mount -a -t lustre
```

Note

This command assumes that all the OSTs are listed in the `/etc/fstab` file. OSTs that are not listed in the `/etc/fstab` file, must be mounted individually by running the mount command:

```
mount -t lustre /dev/block_device/mount_point
```

- d. Mount the file system on the clients. On each client node, run:

```
client# mount -a -t lustre
```

14 Introduced in Lustre 2.7

(Optional) If you are upgrading from a release before Lustre 2.7, to enable OST FIDs to also store the OST index (to improve reliability of LFSCK and debug messages), *after* the OSTs are mounted run once on each OSS:

```
oss# lctl set_param osd-ldiskfs.*.osd_index_in_idif=1
```

Note

Enabling the `index_in_idif` feature will prevent the OST from being used by older versions of Lustre, so it should only be enabled once it is known there is no need for the OST to be downgraded to an earlier release.

- 15.If a new MDT was added to the filesystem, the new MDT must be attached into the namespace by creating one or more *new* DNE subdirectories with the `lfs mkdir` command that use the new MDT:

```
client# lfs mkdir -i new_mdt_index /testfs/new_dir
```

Introduced in Lustre 2.8

In Lustre 2.8 and later, it is possible to split a new directory across multiple MDTs by creating it with multiple stripes:

```
client# lfs mkdir -c 2 /testfs/new_stripped_dir
```

Introduced in Lustre 2.13

In Lustre 2.13 and later, it is possible to set the default directory layout on *existing* directories so new remote subdirectories are created on less-full MDTs:

```
client# lfs setdirstripe -D -c 1 -i -1 /testfs/some_dir
```

See Section 13.10.1, “Directory creation by space/inode usage” for details.

Introduced in Lustre 2.15

In Lustre 2.15 and later, if no default directory layout is set on the root directory, the MDS will *automatically* set the default directory layout the root directory to distribute the top-level directories round-robin across all MDTs, see Section 13.10.2, “Filesystem-wide default directory striping”.

Note

The mounting order described in the steps above must be followed for the initial mount and registration of a Lustre file system after an upgrade. For a normal start of a Lustre file system, the mounting order is MGT, OSTs, MDT(s), clients.

If you have a problem upgrading a Lustre file system, see Section 35.2, “Reporting a Lustre File System Bug” for ways to get help.

17.3. Upgrading to Lustre Software Release 2.x.y (Minor Release)

Rolling upgrades are supported for upgrading from any Lustre software release 2.x.y to a more recent Lustre software release 2.X.y. This allows the Lustre file system to continue to run while individual servers (or their failover partners) and clients are upgraded one at a time. The procedure for upgrading a Lustre software release 2.x.y to a more recent minor release is described in this section.

To upgrade Lustre software release 2.x.y to a more recent minor release, complete these steps:

1. Create a complete, restorable file system backup.

Caution

Before installing the Lustre software, back up ALL data. The Lustre software contains kernel modifications that interact with storage devices and may introduce security issues and data loss if not installed, configured, or administered properly. If a full backup of the file system is not practical, a device-level backup of the MDT file system is recommended. See Chapter 18, *Backing Up and Restoring a File System* for a procedure.

2. Download the Lustre server RPMs for your platform from the Lustre Releases [<https://wiki.whamcloud.com/display/PUB/Lustre+Releases>] repository. See Table 8.1, “Packages Installed on Lustre Servers” for a list of required packages.
3. For a rolling upgrade, complete any procedures required to keep the Lustre file system running while the server to be upgraded is offline, such as failing over a primary server to its secondary partner.
4. Unmount the Lustre server to be upgraded (MGS, MDS, or OSS)
5. Install the Lustre server packages on the Lustre server.
 - a. Log onto the Lustre server as the `root` user
 - b. Use the `yum` command to install the packages:

```
# yum --nogpgcheck install pkg1.rpm pkg2.rpm ...
```
 - c. Verify the packages are installed correctly:

```
rpm -qa | egrep "lustre|wc"
```

- d. Mount the Lustre server to restart the Lustre software on the server:

```
server# mount -a -t lustre
```

- e. Repeat these steps on each Lustre server.

6. Download the Lustre client RPMs for your platform from the [Lustre Releases \[https://wiki.whamcloud.com/display/PUB/Lustre+Releases\]](https://wiki.whamcloud.com/display/PUB/Lustre+Releases) repository. See Table 8.2, “Packages Installed on Lustre Clients” for a list of required packages.

7. Install the Lustre client packages on each of the Lustre clients to be upgraded.

- a. Log onto a Lustre client as the `root` user.

- b. Use the `yum` command to install the packages:

```
# yum --nogpgcheck install pkg1.rpm pkg2.rpm ...
```

- c. Verify the packages were installed correctly:

```
# rpm -qa | egrep "lustre|kernel"
```

- d. Mount the Lustre client to restart the Lustre software on the client:

```
client# mount -a -t lustre
```

- e. Repeat these steps on each Lustre client.

If you have a problem upgrading a Lustre file system, see Section 35.2, “Reporting a Lustre File System Bug” for some suggestions for how to get help.

Chapter 18. Backing Up and Restoring a File System

This chapter describes how to backup and restore at the file system-level, device-level and file-level in a Lustre file system. Each backup approach is described in the the following sections:

- Section 18.1, “Backing up a File System”
- Section 18.2, “Backing Up and Restoring an MDT or OST (ldiskfs Device Level)”
- Section 18.3, “Backing Up an OST or MDT (Backend File System Level)”
- Section 18.4, “Restoring a File-Level Backup”
- Section 18.5, “Using LVM Snapshots with the Lustre File System”

It is *strongly* recommended that sites perform periodic device-level backup of the MDT(s) (Section 18.2, “Backing Up and Restoring an MDT or OST (ldiskfs Device Level)”), for example twice a week with alternate backups going to a separate device, even if there is not enough capacity to do a full backup of all of the filesystem data. Even if there are separate file-level backups of some or all files in the filesystem, having a device-level backup of the MDT can be very useful in case of MDT failure or corruption. Being able to restore a device-level MDT backup can avoid the significantly longer process of restoring the entire filesystem from backup. Since the MDT is required for access to all files, its loss would otherwise force full restore of the filesystem (if that is even possible) even if the OSTs are still OK.

Performing a periodic device-level MDT backup can be done relatively inexpensively because the storage need only be connected to the primary MDS (it can be manually connected to the backup MDS in the rare case it is needed), and only needs good linear read/write performance. While the device-level MDT backup is not useful for restoring individual files, it is most efficient to handle the case of MDT failure or corruption.

18.1. Backing up a File System

Backing up a complete file system gives you full control over the files to back up, and allows restoration of individual files as needed. File system-level backups are also the easiest to integrate into existing backup solutions.

File system backups are performed from a Lustre client (or many clients working parallel in different directories) rather than on individual server nodes; this is no different than backing up any other file system.

However, due to the large size of most Lustre file systems, it is not always possible to get a complete backup. We recommend that you back up subsets of a file system. This includes subdirectories of the entire file system, filesets for a single user, files incremented by date, and so on, so that restores can be done more efficiently.

Note

Lustre internally uses a 128-bit file identifier (FID) for all files. To interface with user applications, the 64-bit inode numbers are returned by the `stat()`, `fstat()`, and `readdir()` system calls on 64-bit applications, and 32-bit inode numbers to 32-bit applications.

Some 32-bit applications accessing Lustre file systems (on both 32-bit and 64-bit CPUs) may experience problems with the `stat()`, `fstat()` or `readdir()` system calls under certain circumstances, though the Lustre client should return 32-bit inode numbers to these applications.

In particular, if the Lustre file system is exported from a 64-bit client via NFS to a 32-bit client, the Linux NFS server will export 64-bit inode numbers to applications running on the NFS client. If the 32-bit applications are not compiled with Large File Support (LFS), then they return EOVERFLOW errors when accessing the Lustre files. To avoid this problem, Linux NFS clients can use the kernel command-line option "nfs.enable_ino64=0" in order to force the NFS client to export 32-bit inode numbers to the client.

Workaround: We very strongly recommend that backups using `tar(1)` and other utilities that depend on the inode number to uniquely identify an inode to be run on 64-bit clients. The 128-bit Lustre file identifiers cannot be uniquely mapped to a 32-bit inode number, and as a result these utilities may operate incorrectly on 32-bit clients. While there is still a small chance of inode number collisions with 64-bit inodes, the FID allocation pattern is designed to avoid collisions for long periods of usage.

18.1.1. Lustre_rsync

The `lustre_rsync` feature keeps the entire file system in sync on a backup by replicating the file system's changes to a second file system (the second file system need not be a Lustre file system, but it must be sufficiently large). `lustre_rsync` uses Lustre changelogs to efficiently synchronize the file systems without having to scan (directory walk) the Lustre file system. This efficiency is critically important for large file systems, and distinguishes the Lustre `lustre_rsync` feature from other replication/backup solutions.

18.1.1.1. Using Lustre_rsync

The `lustre_rsync` feature works by periodically running `lustre_rsync`, a userspace program used to synchronize changes in the Lustre file system onto the target file system. The `lustre_rsync` utility keeps a status file, which enables it to be safely interrupted and restarted without losing synchronization between the file systems.

The first time that `lustre_rsync` is run, the user must specify a set of parameters for the program to use. These parameters are described in the following table and in Section 44.11, “`lustre_rsync`”. On subsequent runs, these parameters are stored in the the status file, and only the name of the status file needs to be passed to `lustre_rsync`.

Before using `lustre_rsync`:

- Register the changelog user. For details, see the Chapter 44, *System Configuration Utilities*(`changelog_register`) parameter in the Chapter 44, *System Configuration Utilities*(`lctl`).

- AND -

- Verify that the Lustre file system (source) and the replica file system (target) are identical *before* registering the changelog user. If the file systems are discrepant, use a utility, e.g. regular `rsync(not lustre_rsync)`, to make them identical.

The `lustre_rsync` utility uses the following parameters:

Parameter	Description
<code>--source= src</code>	The path to the root of the Lustre file system (source) which will be synchronized. This is a mandatory option if a valid status log created during a previous synchronization operation (<code>--statuslog</code>) is not specified.
<code>--target= tgt</code>	The path to the root where the source file system will be synchronized (target). This is a mandatory option if the status log created during a previous

Parameter	Description
	synchronization operation (<code>--statuslog</code>) is not specified. This option can be repeated if multiple synchronization targets are desired.
<code>--mdt= mdt</code>	The metadata device to be synchronized. A changelog user must be registered for this device. This is a mandatory option if a valid status log created during a previous synchronization operation (<code>--statuslog</code>) is not specified.
<code>--user= userid</code>	The changelog user ID for the specified MDT. To use <code>lustre_rsync</code> , the changelog user must be registered. For details, see the <code>changelog_register</code> parameter in Chapter 44, <i>System Configuration Utilities</i> (<code>lctl</code>). This is a mandatory option if a valid status log created during a previous synchronization operation (<code>--statuslog</code>) is not specified.
<code>--statuslog= log</code>	A log file to which synchronization status is saved. When the <code>lustre_rsync</code> utility starts, if the status log from a previous synchronization operation is specified, then the state is read from the log and otherwise mandatory <code>--source</code> , <code>--target</code> and <code>--mdt</code> options can be skipped. Specifying the <code>--source</code> , <code>--target</code> and/or <code>--mdt</code> options, in addition to the <code>--statuslog</code> option, causes the specified parameters in the status log to be overridden. Command line options take precedence over options in the status log.
<code>--xattr yes/no</code>	Specifies whether extended attributes (<code>xattrs</code>) are synchronized or not. The default is to synchronize extended attributes. Note Disabling <code>xattrs</code> causes Lustre striping information not to be synchronized.
<code>--verbose</code>	Produces verbose output.
<code>--dry-run</code>	Shows the output of <code>lustre_rsync</code> commands (<code>copy</code> , <code>mkdir</code> , etc.) on the target file system without actually executing them.
<code>--abort-on-err</code>	Stops processing the <code>lustre_rsync</code> operation if an error occurs. The default is to continue the operation.

18.1.1.2. `lustre_rsync` Examples

Sample `lustre_rsync` commands are listed below.

Register a changelog user for an MDT (e.g. `testfs-MDT0000`).

```
# lctl --device testfs-MDT0000 changelog_register testfs-MDT0000
Registered changelog userid 'c11'
```

Synchronize a Lustre file system (`/mnt/lustre`) to a target file system (`/mnt/target`).

```
$ lustre_rsync --source=/mnt/lustre --target=/mnt/target \
  --mdt=testfs-MDT0000 --user=c11 --statuslog sync.log --verbose
Lustre filesystem: testfs
MDT device: testfs-MDT0000
Source: /mnt/lustre
Target: /mnt/target
Statuslog: sync.log
Changelog registration: c11
Starting changelog record: 0
```

```
Errors: 0
lustre_rsync took 1 seconds
Changelog records consumed: 22
```

After the file system undergoes changes, synchronize the changes onto the target file system. Only the `statuslog` name needs to be specified, as it has all the parameters passed earlier.

```
$ lustre_rsync --statuslog sync.log --verbose
Replicating Lustre filesystem: testfs
MDT device: testfs-MDT0000
Source: /mnt/lustre
Target: /mnt/target
Statuslog: sync.log
Changelog registration: c11
Starting changelog record: 22
Errors: 0
lustre_rsync took 2 seconds
Changelog records consumed: 42
```

To synchronize a Lustre file system (`/mnt/lustre`) to two target file systems (`/mnt/target1` and `/mnt/target2`).

```
$ lustre_rsync --source=/mnt/lustre --target=/mnt/target1 \
               --target=/mnt/target2 --mdt=testfs-MDT0000 --user=c11 \
               --statuslog sync.log
```

18.2. Backing Up and Restoring an MDT or OST (Idiskfs Device Level)

In some cases, it is useful to do a full device-level backup of an individual device (MDT or OST), before replacing hardware, performing maintenance, etc. Doing full device-level backups ensures that all of the data and configuration files is preserved in the original state and is the easiest method of doing a backup. For the MDT file system, it may also be the fastest way to perform the backup and restore, since it can do large streaming read and write operations at the maximum bandwidth of the underlying devices.

Note

Keeping an updated full backup of the MDT is especially important because permanent failure or corruption of the MDT file system renders the much larger amount of data in all the OSTs largely inaccessible and unusable. The storage needed for one or two full MDT device backups is much smaller than doing a full filesystem backup, and can use less expensive storage than the actual MDT device(s) since it only needs to have good streaming read/write speed instead of high random IOPS.

If hardware replacement is the reason for the backup or if a spare storage device is available, it is possible to do a raw copy of the MDT or OST from one block device to the other, as long as the new device is at least as large as the original device. To do this, run:

```
dd if=/dev/{original} of=/dev/{newdev} bs=4M
```

If hardware errors cause read problems on the original device, use the command below to allow as much data as possible to be read from the original device while skipping sections of the disk with errors:

```
dd if=/dev/{original} of=/dev/{newdev} bs=4k conv=sync,noerror /  
count={original size in 4kB blocks}
```

Even in the face of hardware errors, the `ldiskfs` file system is very robust and it may be possible to recover the file system data after running `e2fsck -fy /dev/{newdev}` on the new device.

With Lustre software version 2.6 and later, the `LFSCK` scanning will automatically move objects from `lost+found` back into its correct location on the OST after directory corruption.

In order to ensure that the backup is fully consistent, the MDT or OST must be unmounted, so that there are no changes being made to the device while the data is being transferred. If the reason for the backup is preventative (i.e. MDT backup on a running MDS in case of future failures) then it is possible to perform a consistent backup from an LVM snapshot. If an LVM snapshot is not available, and taking the MDS offline for a backup is unacceptable, it is also possible to perform a backup from the raw MDT block device. While the backup from the raw device will not be fully consistent due to ongoing changes, the vast majority of `ldiskfs` metadata is statically allocated, and inconsistencies in the backup can be fixed by running `e2fsck` on the backup device, and is still much better than not having any backup at all.

18.3. Backing Up an OST or MDT (Backend File System Level)

This procedure provides an alternative to backup or migrate the data of an OST or MDT at the file level. At the file-level, unused space is omitted from the backup and the process may be completed quicker with a smaller total backup size. Backing up a single OST device is not necessarily the best way to perform backups of the Lustre file system, since the files stored in the backup are not usable without metadata stored on the MDT and additional file stripes that may be on other OSTs. However, it is the preferred method for migration of OST devices, especially when it is desirable to reformat the underlying file system with different configuration options or to reduce fragmentation.

Note

Since Lustre stores internal metadata that maps FIDs to local inode numbers via the Object Index file, they need to be rebuilt at first mount after a restore is detected so that file-level MDT backup and restore is supported. The OI Scrub rebuilds these automatically at first mount after a restore is detected, which may affect MDT performance after mount until the rebuild is completed. Progress can be monitored via `lctl get_param osd-*.*.oi_scrub` on the MDS or OSS node where the target filesystem was restored.

Introduced in Lustre 2.11

18.3.1. Backing Up an OST or MDT (Backend File System Level)

Prior to Lustre software release 2.11.0, we can only do the backend file system level backup and restore process for `ldiskfs`-based systems. The ability to perform a `zfs`-based MDT/OST file system level backup and restore is introduced beginning in Lustre software release 2.11.0. Differing from an `ldiskfs`-based system, index objects must be backed up before the unmount of the target (MDT or OST) in order to be able to restore the file system successfully. To enable index backup on the target, execute the following command on the target server:

```
# lctl set_param osd-*.${fsname}-${target}.index_backup=1
```

`${target}` is composed of the target type (MDT or OST) plus the target index, such as MDT0000, OST0001, and so on.

Note

The `index_backup` is also valid for an `ldiskfs`-based system, that will be used when migrating data between `ldiskfs`-based and `zfs`-based systems as described in Section 18.6, “Migration Between ZFS and `ldiskfs` Target Filesystems”.

18.3.2. Backing Up an OST or MDT

The below examples show backing up an OST filesystem. When backing up an MDT, substitute `mdt` for `ost` in the instructions below.

1. **Umount the target**

2. **Make a mountpoint for the file system.**

```
[oss]# mkdir -p /mnt/ost
```

3. **Mount the file system.**

For `ldiskfs`-based systems:

```
[oss]# mount -t ldiskfs /dev/{ostdev} /mnt/ost
```

For `zfs`-based systems:

- a. Import the pool for the target if it is exported. For example:

```
[oss]# zpool import lustre-ost [-d ${ostdev_dir}]
```

- b. Enable the `canmount` property on the target filesystem. For example:

```
[oss]# zfs set canmount=on ${fsname}-ost/ost
```

You also can specify the mountpoint property. By default, it will be: `/${fsname}-ost/ost`

- c. Mount the target as 'zfs'. For example:

```
[oss]# zfs mount ${fsname}-ost/ost
```

4. **Change to the mountpoint being backed up.**

```
[oss]# cd /mnt/ost
```

5. **Back up the extended attributes.**

```
[oss]# getfattr -R -d -m '.*' -e hex -P . > ea-$(date +%Y%m%d).bak
```

Note

If the `tar(1)` command supports the `--xattr` option (see below), the `getfattr` step may be unnecessary as long as `tar` correctly backs up the `trusted.*` attributes. However, completing this step is not harmful and can serve as an added safety measure.

18.4. Restoring a File-Level Backup

To restore data from a file-level backup, you need to format the device, restore the file data and then restore the EA data.

1. Format the new device.

```
[oss]# mkfs.lustre --ost --index {OST index}
--replace --fstype=${fstype} {other options} /dev/{newdev}
```

2. Set the file system label (**ldiskfs-based systems only**).

```
[oss]# e2label {fsname}-OST{index in hex} /mnt/ost
```

3. Mount the file system.

For ldiskfs-based systems:

```
[oss]# mount -t ldiskfs /dev/{newdev} /mnt/ost
```

For zfs-based systems:

- a. Import the pool for the target if it is exported. For example:

```
[oss]# zpool import lustre-ost [-d ${ostdev_dir}]
```

- b. Enable the canmount property on the target filesystem. For example:

```
[oss]# zfs set canmount=on ${fsname}-ost/ost
```

You also can specify the mountpoint property. By default, it will be: `/${fsname}-ost/ost`

- c. Mount the target as 'zfs'. For example:

```
[oss]# zfs mount ${fsname}-ost/ost
```

4. Change to the new file system mount point.

```
[oss]# cd /mnt/ost
```

5. Restore the file system backup.

```
[oss]# tar xzvpf {backup file} [--xattrs] [--xattrs-include="trusted.*"] [--acls
```

Warning

The `tar --xattrs` option is only available in GNU tar version 1.27 or later or in RHEL 6.3 or newer. The `tar --xattrs-include="trusted.*"` option is *required* for correct restoration of the MDT xattrs when using GNU tar 1.27 or RHEL 7 and newer. Otherwise, the `setfattr` step below should be used.

The `tar --acls` option is needed for correct restoration of POSIX ACLs on MDTs. Alternatively, `getfacl -n -R` and `setfacl --restore` can be used instead.

The `tar -P` (or `--absolute-names`) option can be used to speed up extraction of a trusted MDT backup archive.

6. If not using a version of tar that supports direct xattr backups, restore the file system extended attributes.

```
[oss]# setfattr --restore=ea-`${date}`.bak
```

Note

If `--xattrs` option is supported by tar and specified in the step above, this step is redundant.

7. Verify that the extended attributes were restored.

```
[oss]# getfattr -d -m ".*" -e hex O/0/d0/100992 trusted.fid= \  
0x0d822200000000004a8a73e500000000808a01000000000000000000000000
```

8. Remove old OI and LFSCK files.

```
[oss]# rm -rf oi.16* lfsck_* LFSCK
```

9. Remove old CATALOGS.

```
[oss]# rm -f CATALOGS
```

Note

This is optional for the MDT side only. The CATALOGS record the llog file handlers that are used for recovering cross-server updates. Before OI scrub rebuilds the OI mappings for the llog files, the related recovery will get a failure if it runs faster than the background OI scrub. This will result in a failure of the whole mount process. OI scrub is an online tool, therefore, a mount failure means that the OI scrub will be stopped. Removing the old CATALOGS will avoid this potential trouble. The side-effect of removing old CATALOGS is that the recovery for related cross-server updates will be aborted. However, this can be handled by LFSCK after the system mount is up.

10. Change directory out of the file system.

```
[oss]# cd -
```

11. Unmount the new file system.

```
[oss]# umount /mnt/ost
```

Note

If the restored system has a different NID from the backup system, please change the NID. For detail, please refer to Section 14.5, “Changing a Server NID”. For example:

```
[oss]# mount -t lustre -o nosvc ${fsname}-ost/ost /mnt/ost  
[oss]# lctl replace_nids ${fsname}-OSTxxxx $new_nids  
[oss]# umount /mnt/ost
```

12. Mount the target as lustre.

Usually, we will use the `-o abort_recov` option to skip unnecessary recovery. For example:

```
[oss]# mount -t lustre -o abort_recov #${fsname}-ost/ost /mnt/ost
```

Lustre can detect the restore automatically when mounting the target, and then trigger OI scrub to rebuild the OIs and index objects asynchronously in the background. You can check the OI scrub status with the following command:

```
[oss]# lctl get_param -n osd- $\{fstype\}$ . $\{fsname\}$ - $\{target\}$ .oi_scrub
```

If the file system was used between the time the backup was made and when it was restored, then the online LFSCK tool will automatically be run to ensure the filesystem is coherent. If all of the device filesystems were backed up at the same time after Lustre was stopped, this step is unnecessary. In either case, the filesystem will be immediately although there may be I/O errors reading from files that are present on the MDT but not the OSTs, and files that were created after the MDT backup will not be accessible or visible. See Section 36.4, “Checking the file system with LFSCK” for details on using LFSCK.

18.5. Using LVM Snapshots with the Lustre File System

If you want to perform disk-based backups (because, for example, access to the backup system needs to be as fast as to the primary Lustre file system), you can use the Linux LVM snapshot tool to maintain multiple, incremental file system backups.

Because LVM snapshots cost CPU cycles as new files are written, taking snapshots of the main Lustre file system will probably result in unacceptable performance losses. You should create a new, backup Lustre file system and periodically (e.g., nightly) back up new/changed files to it. Periodic snapshots can be taken of this backup file system to create a series of “full” backups.

Note

Creating an LVM snapshot is not as reliable as making a separate backup, because the LVM snapshot shares the same disks as the primary MDT device, and depends on the primary MDT device for much of its data. If the primary MDT device becomes corrupted, this may result in the snapshot being corrupted.

18.5.1. Creating an LVM-based Backup File System

Use this procedure to create a backup Lustre file system for use with the LVM snapshot mechanism.

1. Create LVM volumes for the MDT and OSTs.

Create LVM devices for your MDT and OST targets. Make sure not to use the entire disk for the targets; save some room for the snapshots. The snapshots start out as 0 size, but grow as you make changes to the current file system. If you expect to change 20% of the file system between backups, the most recent snapshot will be 20% of the target size, the next older one will be 40%, etc. Here is an example:

```
cfs21:~# pvcreate /dev/sda1
Physical volume "/dev/sda1" successfully created
cfs21:~# vgcreate vgmain /dev/sda1
Volume group "vgmain" successfully created
cfs21:~# lvcreate -L200G -nMDT0 vgmain
Logical volume "MDT0" created
cfs21:~# lvcreate -L200G -nOST0 vgmain
Logical volume "OST0" created
```

Backing Up and Restoring a File System

```
cfs21:~# lvscan
ACTIVE                '/dev/vgmain/MDT0' [200.00 GB] inherit
ACTIVE                '/dev/vgmain/OST0' [200.00 GB] inherit
```

2. Format the LVM volumes as Lustre targets.

In this example, the backup file system is called main and designates the current, most up-to-date backup.

```
cfs21:~# mkfs.lustre --fsname=main --mdt --index=0 /dev/vgmain/MDT0
No management node specified, adding MGS to this MDT.
Permanent disk data:
Target:      main-MDT0000
Index:       0
Lustre FS:   main
Mount type:  ldiskfs
Flags:       0x75
              (MDT MGS first_time update )
Persistent mount opts: errors=remount-ro,iopen_nopriv,user_xattr
Parameters:
checking for existing Lustre data
device size = 200GB
formatting backing filesystem ldiskfs on /dev/vgmain/MDT0
target name  main-MDT0000
4k blocks    0
options      -i 4096 -I 512 -q -O dir_index -F
mkfs_cmd = mkfs.ext2 -j -b 4096 -L main-MDT0000 -i 4096 -I 512 -q
-O dir_index -F /dev/vgmain/MDT0
Writing CONFIGS/mountdata
cfs21:~# mkfs.lustre --mgsnode=cfs21 --fsname=main --ost --index=0
/dev/vgmain/OST0
Permanent disk data:
Target:      main-OST0000
Index:       0
Lustre FS:   main
Mount type:  ldiskfs
Flags:       0x72
              (OST first_time update )
Persistent mount opts: errors=remount-ro,extents,mballoc
Parameters:  mgsnode=192.168.0.21@tcp
checking for existing Lustre data
device size = 200GB
formatting backing filesystem ldiskfs on /dev/vgmain/OST0
target name  main-OST0000
4k blocks    0
options      -I 256 -q -O dir_index -F
mkfs_cmd = mkfs.ext2 -j -b 4096 -L lustre-OST0000 -J size=400 -I 256
-i 262144 -O extents,uninit_bg,dir_nlink,huge_file,flex_bg -G 256
-E resize=4290772992,lazy_journal_init, -F /dev/vgmain/OST0
Writing CONFIGS/mountdata
cfs21:~# mount -t lustre /dev/vgmain/MDT0 /mnt/mdt
cfs21:~# mount -t lustre /dev/vgmain/OST0 /mnt/ost
cfs21:~# mount -t lustre cfs21:/main /mnt/main
```

18.5.2. Backing up New/Changed Files to the Backup File System

At periodic intervals e.g., nightly, back up new and changed files to the LVM-based backup file system.

```
cfs21:~# cp /etc/passwd /mnt/main

cfs21:~# cp /etc/fstab /mnt/main

cfs21:~# ls /mnt/main
fstab  passwd
```

18.5.3. Creating Snapshot Volumes

Whenever you want to make a "checkpoint" of the main Lustre file system, create LVM snapshots of all target MDT and OSTs in the LVM-based backup file system. You must decide the maximum size of a snapshot ahead of time, although you can dynamically change this later. The size of a daily snapshot is dependent on the amount of data changed daily in the main Lustre file system. It is likely that a two-day old snapshot will be twice as big as a one-day old snapshot.

You can create as many snapshots as you have room for in the volume group. If necessary, you can dynamically add disks to the volume group.

The snapshots of the target MDT and OSTs should be taken at the same point in time. Make sure that the cronjob updating the backup file system is not running, since that is the only thing writing to the disks. Here is an example:

```
cfs21:~# modprobe dm-snapshot
cfs21:~# lvcreate -L50M -s -n MDT0.b1 /dev/vgmain/MDT0
  Rounding up size to full physical extent 52.00 MB
  Logical volume "MDT0.b1" created
cfs21:~# lvcreate -L50M -s -n OST0.b1 /dev/vgmain/OST0
  Rounding up size to full physical extent 52.00 MB
  Logical volume "OST0.b1" created
```

After the snapshots are taken, you can continue to back up new/changed files to "main". The snapshots will not contain the new files.

```
cfs21:~# cp /etc/termcap /mnt/main
cfs21:~# ls /mnt/main
fstab  passwd  termcap
```

18.5.4. Restoring the File System From a Snapshot

Use this procedure to restore the file system from an LVM snapshot.

1. Rename the LVM snapshot.

Rename the file system snapshot from "main" to "back" so you can mount it without unmounting "main". This is recommended, but not required. Use the `--reformat` flag to `tunefs.lustre` to force the name change. For example:

```
cfs21:~# tunefs.lustre --reformat --fsname=back --writeconf /dev/vgmain/MDT0.b1
checking for existing Lustre data
found Lustre data
```

```
Reading CONFIGS/mountdata
Read previous values:
Target:      main-MDT0000
Index:       0
Lustre FS:   main
Mount type:  ldiskfs
Flags:       0x5
              (MDT MGS )
Persistent mount opts: errors=remount-ro,iopen_nopriv,user_xattr
Parameters:
Permanent disk data:
Target:      back-MDT0000
Index:       0
Lustre FS:   back
Mount type:  ldiskfs
Flags:       0x105
              (MDT MGS writeconf )
Persistent mount opts: errors=remount-ro,iopen_nopriv,user_xattr
Parameters:
Writing CONFIGS/mountdata
cfs21:~# tunefs.lustre --reformat --fsname=back --writeconf /dev/vgmain/OST0.b1
checking for existing Lustre data
found Lustre data
Reading CONFIGS/mountdata
Read previous values:
Target:      main-OST0000
Index:       0
Lustre FS:   main
Mount type:  ldiskfs
Flags:       0x2
              (OST )
Persistent mount opts: errors=remount-ro,extents,malloc
Parameters: mgsnode=192.168.0.21@tcp
Permanent disk data:
Target:      back-OST0000
Index:       0
Lustre FS:   back
Mount type:  ldiskfs
Flags:       0x102
              (OST writeconf )
Persistent mount opts: errors=remount-ro,extents,malloc
Parameters: mgsnode=192.168.0.21@tcp
Writing CONFIGS/mountdata
```

When renaming a file system, we must also erase the `last_rcvd` file from the snapshots

```
cfs21:~# mount -t ldiskfs /dev/vgmain/MDT0.b1 /mnt/mdtback
cfs21:~# rm /mnt/mdtback/last_rcvd
cfs21:~# umount /mnt/mdtback
cfs21:~# mount -t ldiskfs /dev/vgmain/OST0.b1 /mnt/ostback
cfs21:~# rm /mnt/ostback/last_rcvd
cfs21:~# umount /mnt/ostback
```

2. Mount the file system from the LVM snapshot. For example:

```
cfs21:~# mount -t lustre /dev/vgmain/MDT0.b1 /mnt/mdtback
cfs21:~# mount -t lustre /dev/vgmain/OST0.b1 /mnt/ostback
cfs21:~# mount -t lustre cfs21:/back /mnt/back
```

3. Note the old directory contents, as of the snapshot time. For example:

```
cfs21:~/cfs/b1_5/lustre/utils# ls /mnt/back
fstab  passwd
```

18.5.5. Deleting Old Snapshots

To reclaim disk space, you can erase old snapshots as your backup policy dictates. Run:

```
lvremove /dev/vgmain/MDT0.b1
```

18.5.6. Changing Snapshot Volume Size

You can also extend or shrink snapshot volumes if you find your daily deltas are smaller or larger than expected. Run:

```
lvextend -L10G /dev/vgmain/MDT0.b1
```

Note

Extending snapshots seems to be broken in older LVM. It is working in LVM v2.02.01.

Introduced in Lustre 2.11

18.6. Migration Between ZFS and Idiskfs Target Filesystems

Beginning with Lustre 2.11.0, it is possible to migrate between ZFS and Idiskfs backends. For migrating OSTs, it is best to use `lfs find/lfs_migrate` to empty out an OST while the filesystem is in use and then reformat it with the new fstype. For instructions on removing the OST, please see Section 14.9.3, “Removing an OST from the File System”.

18.6.1. Migrate from a ZFS to an Idiskfs based filesystem

The first step of the process is to make a ZFS backend backup using `tar` as described in Section 18.3, “Backing Up an OST or MDT (Backend File System Level)”.

Next, restore the backup to an Idiskfs-based system as described in Section 18.4, “Restoring a File-Level Backup”.

18.6.2. Migrate from an Idiskfs to a ZFS based filesystem

The first step of the process is to make an Idiskfs backend backup using `tar` as described in Section 18.3, “Backing Up an OST or MDT (Backend File System Level)”.

Caution:For a migration from `ldiskfs` to `zfs`, it is required to enable `index_backup` before the unmount of the target. This is an additional step for a regular `ldiskfs`-based backup/restore and easy to be missed.

Next, restore the backup to an `ldiskfs`-based system as described in Section 18.4, “Restoring a File-Level Backup”.

Chapter 19. Managing File Layout (Striping) and Free Space

This chapter describes file layout (striping) and I/O options, and includes the following sections:

- Section 19.1, “How Lustre File System Striping Works”
- Section 19.2, “Lustre File Layout (Striping) Considerations”
- Section 19.3, “Setting the File Layout/Striping Configuration (`lfs setstripe`)”
- Section 19.4, “Retrieving File Layout/Striping Information (`getstripe`)”
- Section 19.8, “Managing Free Space”
- Section 19.9, “Lustre Striping Internals”

19.1. How Lustre File System Striping Works

In a Lustre file system, the MDS allocates objects to OSTs using either a round-robin algorithm or a weighted algorithm. When the amount of free space is well balanced (i.e., by default, when the free space across OSTs differs by less than 17%), the round-robin algorithm is used to select the next OST to which a stripe is to be written. Periodically, the MDS adjusts the striping layout to eliminate some degenerated cases in which applications that create very regular file layouts (striping patterns) preferentially use a particular OST in the sequence.

Normally the usage of OSTs is well balanced. However, if users create a small number of exceptionally large files or incorrectly specify striping parameters, imbalanced OST usage may result. When the free space across OSTs differs by more than a specific amount (17% by default), the MDS then uses weighted random allocations with a preference for allocating objects on OSTs with more free space. (This can reduce I/O performance until space usage is rebalanced again.) For a more detailed description of how striping is allocated, see Section 19.8, “Managing Free Space”.

Files can only be striped over a finite number of OSTs, based on the maximum size of the attributes that can be stored on the MDT. If the MDT is `ldiskfs`-based without the `ea_inode` feature, a file can be striped across at most 160 OSTs. With a `ZFS`-based MDT, or if the `ea_inode` feature is enabled for an `ldiskfs`-based MDT (the default since Lustre 2.13.0), a file can be striped across up to 2000 OSTs. For more information, see Section 19.9, “Lustre Striping Internals”.

19.2. Lustre File Layout (Striping) Considerations

Whether you should set up file striping and what parameter values you select depends on your needs. A good rule of thumb is to stripe over as few objects as will meet those needs and no more.

Some reasons for using striping include:

- **Providing high-bandwidth access.** Many applications require high-bandwidth access to a single file, which may be more bandwidth than can be provided by a single OSS. Examples are a scientific application that writes to a single file from hundreds of nodes, or a binary executable that is loaded by many nodes when an application starts.

In cases like these, a file can be striped over as many OSSs as it takes to achieve the required peak aggregate bandwidth for that file. Striping across a larger number of OSSs should only be used when the file size is very large and/or is accessed by many nodes at a time. Currently, Lustre files can be striped across up to 2000 OSTs

- **Improving performance when OSS bandwidth is exceeded.** Striping across many OSSs can improve performance if the aggregate client bandwidth exceeds the server bandwidth and the application reads and writes data fast enough to take advantage of the additional OSS bandwidth. The largest useful stripe count is bounded by the I/O rate of the clients/jobs divided by the performance per OSS.

Introduced in Lustre 2.13

Matching stripes to I/O pattern. When writing to a single file from multiple nodes, having more than one client writing to a stripe can lead to issues with lock exchange, where clients contend over writing to that stripe, even if their I/Os do not overlap. This can be avoided if I/O can be stripe aligned so that each stripe is accessed by only one client. Since Lustre 2.13, the 'overstriping' feature is available, allowing more than one stripe per OST. This is particularly helpful for the case where thread count exceeds OST count, making it possible to match stripe count to thread count even in this case.

- **Providing space for very large files.** Striping is useful when a single OST does not have enough free space to hold the entire file.

Some reasons to minimize or avoid striping:

- **Increased overhead.** Striping results in more locks and extra network operations during common operations such as `stat` and `unlink`. Even when these operations are performed in parallel, one network operation takes less time than 100 operations.

Increased overhead also results from server contention. Consider a cluster with 100 clients and 100 OSSs, each with one OST. If each file has exactly one object and the load is distributed evenly, there is no contention and the disks on each server can manage sequential I/O. If each file has 100 objects, then the clients all compete with one another for the attention of the servers, and the disks on each node seek in 100 different directions resulting in needless contention.

- **Increased risk.** When files are striped across all servers and one of the servers breaks down, a small part of each striped file is lost. By comparison, if each file has exactly one stripe, fewer files are lost, but they are lost in their entirety. Many users would prefer to lose some of their files entirely than all of their files partially.
- **Small files.** Small files do not benefit from striping because they can be efficiently stored and accessed as a single OST object or even with Data on MDT.
- **O_APPEND mode.** When files are opened for append, they instantiate all uninitialized components expressed in the layout. Typically, log files are opened for append, and complex layouts can be inefficient.

Note

The `mdd.*.append_stripe_count` and `mdd.*.append_pool` options can be used to specify special default striping for files created with `O_APPEND`.

19.2.1. Choosing a Stripe Size

Choosing a stripe size is a balancing act, but reasonable defaults are described below. The stripe size has no effect on a single-stripe file.

- **The stripe size must be a multiple of the page size.** Lustre software tools enforce a multiple of 64 KB (the maximum page size on ia64 and PPC64 nodes) so that users on platforms with smaller pages do not accidentally create files that might cause problems for ia64 clients.
- **The smallest recommended stripe size is 512 KB.** Although you can create files with a stripe size of 64 KB, the smallest practical stripe size is 512 KB because the Lustre file system sends 1MB chunks over the network. Choosing a smaller stripe size may result in inefficient I/O to the disks and reduced performance.
- **A good stripe size for sequential I/O using high-speed networks is between 1 MB and 4 MB.** In most situations, stripe sizes larger than 4 MB may result in longer lock hold times and contention during shared file access.
- **The maximum stripe size is 4 GB.** Using a large stripe size can improve performance when accessing very large files. It allows each client to have exclusive access to its own part of a file. However, a large stripe size can be counterproductive in cases where it does not match your I/O pattern.
- **Choose a stripe pattern that takes into account the write patterns of your application.** Writes that cross an object boundary are slightly less efficient than writes that go entirely to one server. If the file is written in a consistent and aligned way, make the stripe size a multiple of the `write()` size.

19.3. Setting the File Layout/Striping Configuration (`lfs setstripe`)

Use the `lfs setstripe` command to create new files with a specific file layout (stripe pattern) configuration.

```
lfs setstripe [--size|-s stripe_size] [--stripe-count|-c stripe_count] [--overstri  
[--index|-i start_ost] [--pool|-p pool_name] filename/dirname
```

stripe_size

The `stripe_size` indicates how much data to write to one OST before moving to the next OST. The default `stripe_size` is 1 MB. Passing a `stripe_size` of 0 causes the default stripe size to be used. Otherwise, the `stripe_size` value must be a multiple of 64 KB.

stripe_count (--stripe-count, --overstripe-count)

The `stripe_count` indicates how many stripes to use. The default `stripe_count` value is 1. Setting `stripe_count` to 0 causes the default stripe count to be used. Setting `stripe_count` to -1 means stripe over all available OSTs (full OSTs are skipped). When `--overstripe-count` is used, per OST if necessary.

start_ost

The start OST is the first OST to which files are written. The default value for `start_ost` is -1, which allows the MDS to choose the starting index. This setting is strongly recommended, as it allows space and load balancing to be done by the MDS as needed. If the value of `start_ost` is set to a value other than -1, the file starts on the specified OST index. OST index numbering starts at 0.

Note

If the specified OST is inactive or in a degraded mode, the MDS will silently choose another target.

Note

If you pass a `start_ost` value of 0 and a `stripe_count` value of 1, all files are written to OST 0, until space is exhausted. *This is probably not what you meant to do.* If you only want to adjust the stripe count and keep the other parameters at their default settings, do not specify any of the other parameters:

```
client# lfs setstripe -c stripe_count filename
```

pool_name

The `pool_name` specifies the OST pool to which the file will be written. This allows limiting the OSTs used to a subset of all OSTs in the file system. For more details about using OST pools, see Section 23.2, “Creating and Managing OST Pools”.

19.3.1. Specifying a File Layout (Striping Pattern) for a Single File

It is possible to specify the file layout when a new file is created using the command `lfs setstripe`. This allows users to override the file system default parameters to tune the file layout more optimally for their application. Execution of an `lfs setstripe` command fails if the file already exists.

19.3.1.1. Setting the Stripe Size

The command to create a new file with a specified stripe size is similar to:

```
[client]# lfs setstripe -s 4M /mnt/lustre/new_file
```

This example command creates the new file `/mnt/lustre/new_file` with a stripe size of 4 MB.

Now, when the file is created, the new stripe setting creates the file on a single OST with a stripe size of 4M:

```
[client]# lfs getstripe /mnt/lustre/new_file
/mnt/lustre/4mb_file
lmm_stripe_count: 1
lmm_stripe_size: 4194304
lmm_pattern: 1
lmm_layout_gen: 0
lmm_stripe_offset: 1
obdidx  objid  objid  group
1        690550  0xa8976  0
```

In this example, the stripe size is 4 MB.

19.3.1.2. Setting the Stripe Count

The command below creates a new file with a stripe count of -1 to specify striping over all available OSTs:

```
[client]# lfs setstripe -c -1 /mnt/lustre/full_stripe
```

The example below indicates that the file `full_stripe` is striped over all six active OSTs in the configuration:

```
[client]# lfs getstripe /mnt/lustre/full_stripe
/mnt/lustre/full_stripe
```

obdidx	objid	objid	group
0	8	0x8	0
1	4	0x4	0
2	5	0x5	0
3	5	0x5	0
4	4	0x4	0
5	2	0x2	0

This is in contrast to the output in Section 19.3.1.1, “Setting the Stripe Size”, which shows only a single object for the file.

19.3.2. Setting the Striping Layout for a Directory

In a directory, the `lfs setstripe` command sets a default striping configuration for files created in the directory. The usage is the same as `lfs setstripe` for a regular file, except that the directory must exist prior to setting the default striping configuration. If a file is created in a directory with a default stripe configuration (without otherwise specifying striping), the Lustre file system uses those striping parameters instead of the file system default for the new file.

To change the striping pattern for a sub-directory, create a directory with desired file layout as described above. Sub-directories inherit the file layout of the root/parent directory.

Note

Special default striping can be used for files created with `O_APPEND`. Files with uninitialized layouts opened with `O_APPEND` will override a directory's default striping configuration and abide by the `mdd.*.append_pool` and `mdd.*.append_stripe_count` options (if they are specified).

19.3.3. Setting the Striping Layout for a File System

Setting the striping specification on the `root` directory determines the striping for all new files created in the file system unless an overriding striping specification takes precedence (such as a striping layout specified by the application, or set using `lfs setstripe`, or specified for the parent directory).

Note

The striping settings for a `root` directory are, by default, applied to any new child directories created in the root directory, unless striping settings have been specified for the child directory.

Note

Special default striping can be used for files created with `O_APPEND`. Files with uninitialized layouts opened with `O_APPEND` will override a file system's default striping configuration and abide by the `mdd.*.append_pool` and `mdd.*.append_stripe_count` options (if they are specified).

19.3.4. Per File System Stripe Count Limit

Sometime there are many OSTs in a filesystem, but it is not always desirable to stripe file to across all OSTs, even if the given `stripe_count=-1` (unlimited). In this case, the per-filesystem tunable parameter `lod.*.max_stripecount` can be used to limit the real stripe count of file to a lower number than the OST count. If `lod.*.max_stripecount` is not 0, and

the file `stripe_count=-1`, the real stripe count will be the minimum of the OST count and `max_stripecount`. If `lod.*.max_stripecount=0`, or an explicit stripe count is given for the file, it is ignored.

To set `max_stripecount`, on all MDSEs of file system, run:

```
msg# lctl set_param -P lod.$fsname-MDTxxxx-mdtlov.max_stripecount=<N>
```

To check `max_stripecount`, run:

```
mgs# lctl get_param lod.$fsname-MDTxxxx-mdtlov.max_stripecount
```

To reset `max_stripecount`, run:

```
mgs# lctl set_param -P -d lod.$fsname-MDTxxxx-mdtlov.max_stripecount
```

19.3.5. Creating a File on a Specific OST

You can use `lfs setstripe` to create a file on a specific OST. In the following example, the file `file1` is created on the first OST (OST index is 0).

```
$ lfs setstripe --stripe-count 1 --index 0 file1
$ dd if=/dev/zero of=file1 count=1 bs=100M
1+0 records in
1+0 records out
```

```
$ lfs getstripe file1
/mnt/testfs/file1
lmm_stripe_count: 1
lmm_stripe_size: 1048576
lmm_pattern: 1
lmm_layout_gen: 0
lmm_stripe_offset: 0
      obdidx   objid   objid   group
      0         37364  0x91f4  0
```

19.4. Retrieving File Layout/Striping Information (`getstripe`)

The `lfs getstripe` command is used to display information that shows over which OSTs a file is distributed. For each OST, the index and UUID is displayed, along with the OST index and object ID for each stripe in the file. For directories, the default settings for files created in that directory are displayed.

19.4.1. Displaying the Current Stripe Size

To see the current stripe size for a Lustre file or directory, use the `lfs getstripe` command. For example, to view information for a directory, enter a command similar to:

```
[client]# lfs getstripe /mnt/lustre
```

This command produces output similar to:

```
/mnt/lustre  
(Default) stripe_count: 1 stripe_size: 1M stripe_offset: -1
```

In this example, the default stripe count is 1 (data blocks are striped over a single OST), the default stripe size is 1 MB, and the objects are created over all available OSTs.

To view information for a file, enter a command similar to:

```
$ lfs getstripe /mnt/lustre/foo  
/mnt/lustre/foo  
lmm_stripe_count: 1  
lmm_stripe_size: 1048576  
lmm_pattern: 1  
lmm_layout_gen: 0  
lmm_stripe_offset: 0  
  obdidx  objid  objid  group  
    2      835487  m0xcbf9f  0
```

In this example, the file is located on obdidx 2, which corresponds to the OST `lustre-OST0002`. To see which node is serving that OST, run:

```
$ lctl get_param osc.lustre-OST0002-osc.ost_conn_uuid  
osc.lustre-OST0002-osc.ost_conn_uuid=192.168.20.1@tcp
```

19.4.2. Inspecting the File Tree

To inspect an entire tree of files, use the `lfs find` command:

```
lfs find [--recursive | -r] file/directory ...
```

19.4.3. Locating the MDT for a remote directory

Lustre can be configured with multiple MDTs in the same file system. Each directory and file could be located on a different MDT. To identify which MDT a given subdirectory is located, pass the `getstripe [--mdt-index|-M]` parameter to `lfs`. An example of this command is provided in the section Section 14.9.1, “Removing an MDT from the File System”.

Introduced in Lustre 2.10

19.5. Progressive File Layout(PFL)

The Lustre Progressive File Layout (PFL) feature simplifies the use of Lustre so that users can expect reasonable performance for a variety of normal file IO patterns without the need to explicitly understand their IO model or Lustre usage details in advance. In particular, users do not necessarily need to know the size or concurrency of output files in advance of their creation and explicitly specify an optimal layout for each file in order to achieve good performance for both highly concurrent shared-single-large-file IO or parallel IO to many smaller per-process files.

The layout of a PFL file is stored on disk as `composite layout`. A PFL file is essentially an array of `sub-layout components`, with each sub-layout component being a plain layout covering different

and non-overlapped extents of the file. For PFL files, the file layout is composed of a series of components, therefore it's possible that there are some file extents are not described by any components.

An example of how data blocks of PFL files are mapped to OST objects of components is shown in the following PFL object mapping diagram:

Figure 19.1. PFL object mapping diagram

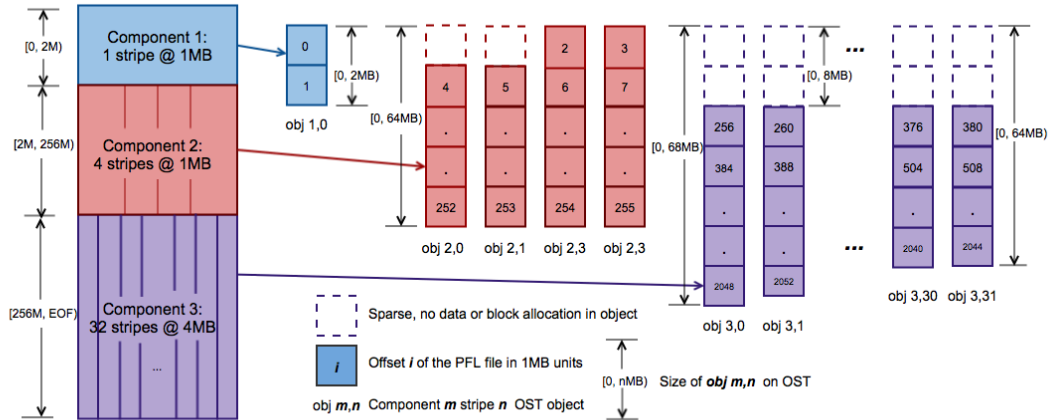

Mapping from 2055MB PFL file data blocks to OST objects of three components

The PFL file in Figure 19.1, “PFL object mapping diagram” has 3 components and shows the mapping for the blocks of a 2055MB file. The stripe size for the first two components is 1MB, while the stripe size for the third component is 4MB. The stripe count is increasing for each successive component. The first component only has two 1MB blocks and the single object has a size of 2MB. The second component holds the next 254MB of the file spread over 4 separate OST objects in RAID-0, each one will have a size of $256MB / 4$ objects = 64MB per object. Note the first two objects $obj\ 2,0$ and $obj\ 2,1$ have a 1MB hole at the start where the data is stored in the first component. The final component holds the next 1800MB spread over 32 OST objects. There is a $256MB / 32 = 8MB$ hole at the start each one for the data stored in the first two components. Each object will be $2048MB / 32$ objects = 64MB per object, except the $obj\ 3,0$ that holds an extra 4MB chunk and $obj\ 3,1$ that holds an extra 3MB chunk. If more data was written to the file, only the objects in component 3 would increase in size.

When a file range with defined but not instantiated component is accessed, clients will send a Layout Intent RPC to the MDT, and the MDT would instantiate the objects of the components covering that range.

Next, some commands for user to operate PFL files are introduced and some examples of possible composite layout are illustrated as well. Lustre provides commands `lfs setstripe` and `lfs migrate` for users to operate PFL files. `lfs setstripe` commands are used to create PFL files, add or delete components to or from an existing composite file; `lfs migrate` commands are used to re-layout the data in existing files using the new layout parameter by copying the data from the existing OST(s) to the new OST(s). Also, as introduced in the previous sections, `lfs getstripe` commands can be used to list the striping/component information for a given PFL file, and `lfs find` commands can be used to search the directory tree rooted at the given directory or file name for the files that match the given PFL component parameters.

Note

Using PFL files requires both the client and server to understand the PFL file layout, which isn't available for Lustre 2.9 and earlier. And it will not prevent older clients from accessing non-PFL files in the filesystem.

19.5.1. lfs setstripe

`lfs setstripe` commands are used to create PFL files, add or delete components to or from an existing composite file. (Suppose we have 8 OSTs in the following examples and stripe size is 1MB by default.)

19.5.1.1. Create a PFL file

Command

```
lfs setstripe
[--component-end|-E end1] [STRIPE_OPTIONS]
[--component-end|-E end2] [STRIPE_OPTIONS] ... filename
```

The `-E` option is used to specify the end offset (in bytes or using a suffix “kMGTP”, e.g. 256M) of each component, and it also indicates the following `STRIPE_OPTIONS` are for this component. Each component defines the stripe pattern of the file in the range of [start, end). The first component must start from offset 0 and all components must be adjacent with each other, no holes are allowed, so each extent will start at the end of previous extent. A `-1` end offset or `eof` indicates this is the last component extending to the end of file.

Example

```
$ lfs setstripe -E 4M -c 1 -E 64M -c 4 -E -1 -c -1 -i 4 \
/mnt/testfs/create_comp
```

This command creates a file with composite layout illustrated in the following figure. The first component has 1 stripe and covers [0, 4M), the second component has 4 stripes and covers [4M, 64M), and the last component stripes start at OST4, cross over all available OSTs and covers [64M, EOF).

Figure 19.2. Example: create a composite file

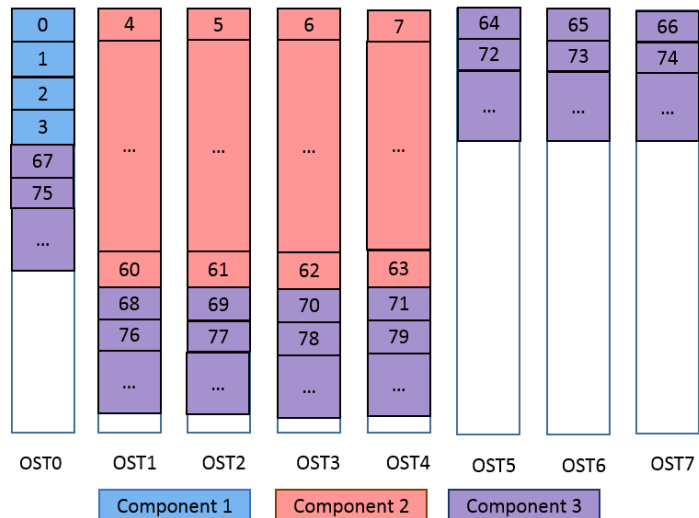

The composite layout can be output by the following command:

```
$ lfs getstripe /mnt/testfs/create_comp
/mnt/testfs/create_comp
lcm_layout_gen: 3
```

```
lcm_entry_count: 3
  lcme_id:      1
  lcme_flags:   init
  lcme_extent.e_start: 0
  lcme_extent.e_end: 4194304
    lmm_stripe_count: 1
    lmm_stripe_size: 1048576
    lmm_pattern: 1
    lmm_layout_gen: 0
    lmm_stripe_offset: 0
    lmm_objects:
      - 0: { l_ost_idx: 0, l_fid: [0x100000000:0x2:0x0] }

  lcme_id:      2
  lcme_flags:   0
  lcme_extent.e_start: 4194304
  lcme_extent.e_end: 67108864
    lmm_stripe_count: 4
    lmm_stripe_size: 1048576
    lmm_pattern: 1
    lmm_layout_gen: 0
    lmm_stripe_offset: -1
  lcme_id:      3
  lcme_flags:   0
  lcme_extent.e_start: 67108864
  lcme_extent.e_end: EOF
    lmm_stripe_count: -1
    lmm_stripe_size: 1048576
    lmm_pattern: 1
    lmm_layout_gen: 0
    lmm_stripe_offset: 4
```

Note

Only the first component's OST objects of the PFL file are instantiated when the layout is being set. Other instantiation is delayed to later write/truncate operations.

If we write 128M data to this PFL file, the second and third components will be instantiated:

```
$ dd if=/dev/zero of=/mnt/testfs/create_comp bs=1M count=128
$ lfs getstripe /mnt/testfs/create_comp
/mnt/testfs/create_comp
  lcm_layout_gen: 5
  lcm_entry_count: 3
    lcme_id:      1
    lcme_flags:   init
    lcme_extent.e_start: 0
    lcme_extent.e_end: 4194304
      lmm_stripe_count: 1
      lmm_stripe_size: 1048576
      lmm_pattern: 1
      lmm_layout_gen: 0
      lmm_stripe_offset: 0
      lmm_objects:
```

```
- 0: { l_ost_idx: 0, l_fid: [0x100000000:0x2:0x0] }

lcme_id:          2
lcme_flags:       init
lcme_extent.e_start: 4194304
lcme_extent.e_end: 67108864
  lmm_stripe_count: 4
  lmm_stripe_size: 1048576
  lmm_pattern:     1
  lmm_layout_gen: 0
  lmm_stripe_offset: 1
  lmm_objects:
    - 0: { l_ost_idx: 1, l_fid: [0x100010000:0x2:0x0] }
    - 1: { l_ost_idx: 2, l_fid: [0x100020000:0x2:0x0] }
    - 2: { l_ost_idx: 3, l_fid: [0x100030000:0x2:0x0] }
    - 3: { l_ost_idx: 4, l_fid: [0x100040000:0x2:0x0] }

lcme_id:          3
lcme_flags:       init
lcme_extent.e_start: 67108864
lcme_extent.e_end: EOF
  lmm_stripe_count: 8
  lmm_stripe_size: 1048576
  lmm_pattern:     1
  lmm_layout_gen: 0
  lmm_stripe_offset: 4
  lmm_objects:
    - 0: { l_ost_idx: 4, l_fid: [0x100040000:0x3:0x0] }
    - 1: { l_ost_idx: 5, l_fid: [0x100050000:0x2:0x0] }
    - 2: { l_ost_idx: 6, l_fid: [0x100060000:0x2:0x0] }
    - 3: { l_ost_idx: 7, l_fid: [0x100070000:0x2:0x0] }
    - 4: { l_ost_idx: 0, l_fid: [0x100000000:0x3:0x0] }
    - 5: { l_ost_idx: 1, l_fid: [0x100010000:0x3:0x0] }
    - 6: { l_ost_idx: 2, l_fid: [0x100020000:0x3:0x0] }
    - 7: { l_ost_idx: 3, l_fid: [0x100030000:0x3:0x0] }
```

19.5.1.2. Add component(s) to an existing composite file

Command

```
lfs setstripe --component-add
[--component-end|-E end1] [STRIPE_OPTIONS]
[--component-end|-E end2] [STRIPE_OPTIONS] ... filename
```

The option `--component-add` is used to add components to an existing composite file. The extent start of the first component to be added is equal to the extent end of last component in the existing file, and all components to be added must be adjacent with each other.

Note

If the last existing component is specified by `-E -1` or `-E eof`, which covers to the end of the file, it must be deleted before a new one is added.

Example

```
$ lfs setstripe -E 4M -c 1 -E 64M -c 4 /mnt/testfs/add_comp
$ lfs setstripe --component-add -E -1 -c 4 -o 6-7,0,5 \
/mnt/testfs/add_comp
```

This command adds a new component which starts from the end of the last existing component to the end of file. The layout of this example is illustrated in Figure 19.3, “Example: add a component to an existing composite file”. The last component stripes across 4 OSTs in sequence OST6, OST7, OST0 and OST5, covers [64M, EOF).

Figure 19.3. Example: add a component to an existing composite file

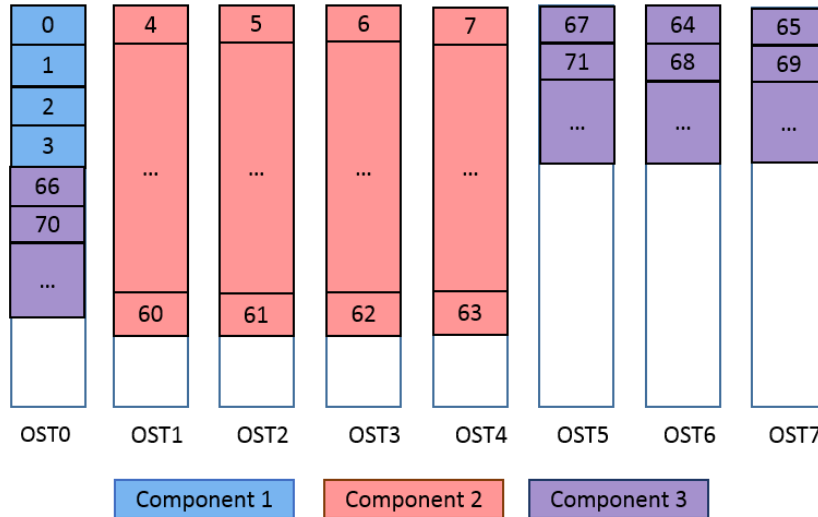

The layout can be printed out by the following command:

```
$ lfs getstripe /mnt/testfs/add_comp
/mnt/testfs/add_comp
lcm_layout_gen: 5
lcm_entry_count: 3
  lcme_id: 1
  lcme_flags: init
  lcme_extent.e_start: 0
  lcme_extent.e_end: 4194304
  lmm_stripe_count: 1
  lmm_stripe_size: 1048576
  lmm_pattern: 1
  lmm_layout_gen: 0
  lmm_stripe_offset: 0
  lmm_objects:
  - 0: { l_ost_idx: 0, l_fid: [0x100000000:0x2:0x0] }

  lcme_id: 2
  lcme_flags: init
  lcme_extent.e_start: 4194304
  lcme_extent.e_end: 67108864
  lmm_stripe_count: 4
  lmm_stripe_size: 1048576
  lmm_pattern: 1
```

```
lmm_layout_gen:    0
lmm_stripe_offset: 1
lmm_objects:
- 0: { l_ost_idx: 1, l_fid: [0x100010000:0x2:0x0] }
- 1: { l_ost_idx: 2, l_fid: [0x100020000:0x2:0x0] }
- 2: { l_ost_idx: 3, l_fid: [0x100030000:0x2:0x0] }
- 3: { l_ost_idx: 4, l_fid: [0x100040000:0x2:0x0] }

lcme_id:           5
lcme_flags:        0
lcme_extent.e_start: 67108864
lcme_extent.e_end: EOF
  lmm_stripe_count: 4
  lmm_stripe_size:  1048576
  lmm_pattern:      1
  lmm_layout_gen:   0
  lmm_stripe_offset: -1
```

The component ID "lcme_id" changes as layout generation changes. It is not necessarily sequential and does not imply ordering of individual components.

Note

Similar to specifying a full-file composite layout at file creation time, `--component-add` won't instantiate OST objects, the instantiation is delayed to later write/truncate operations. For example, after writing beyond the 64MB start of the file's last component, the new component has had objects allocated:

```
$ lfs getstripe -I5 /mnt/testfs/add_comp
/mnt/testfs/add_comp
lcm_layout_gen:  6
lcm_entry_count: 3
  lcme_id:        5
  lcme_flags:     init
  lcme_extent.e_start: 67108864
  lcme_extent.e_end: EOF
    lmm_stripe_count: 4
    lmm_stripe_size:  1048576
    lmm_pattern:      1
    lmm_layout_gen:   0
    lmm_stripe_offset: 6
    lmm_objects:
- 0: { l_ost_idx: 6, l_fid: [0x100060000:0x4:0x0] }
- 1: { l_ost_idx: 7, l_fid: [0x100070000:0x4:0x0] }
- 2: { l_ost_idx: 0, l_fid: [0x100000000:0x5:0x0] }
- 3: { l_ost_idx: 5, l_fid: [0x100050000:0x4:0x0] }
```

19.5.1.3. Delete component(s) from an existing file

Command

```
lfs setstripe --component-del
[--component-id|-I comp_id | --component-flags comp_flags]
filename
```

The option `--component-del` is used to remove the component(s) specified by component ID or flags from an existing file. Any data stored in the deleted component will be lost after this operation.

The ID specified by `-I` option is the numerical unique ID of the component, which can be obtained by command `lfs getstripe -I command`, and the flag specified by `--component-flags` option is a certain type of components, which can be obtained by command `lfs getstripe --component-flags`. For now, we only have two flags `init` and `^init` for instantiated and un-instantiated components respectively.

Note

Deletion must start with the last component because creation of a hole in the middle of a file layout is not allowed.

Example

```
$ lfs getstripe -I /mnt/testfs/del_comp
1
2
5
$ lfs setstripe --component-del -I 5 /mnt/testfs/del_comp
```

This example deletes the component with ID 5 from file `/mnt/testfs/del_comp`. If we still use the last example, the final result is illustrated in Figure 19.4, “Example: delete a component from an existing file”.

Figure 19.4. Example: delete a component from an existing file

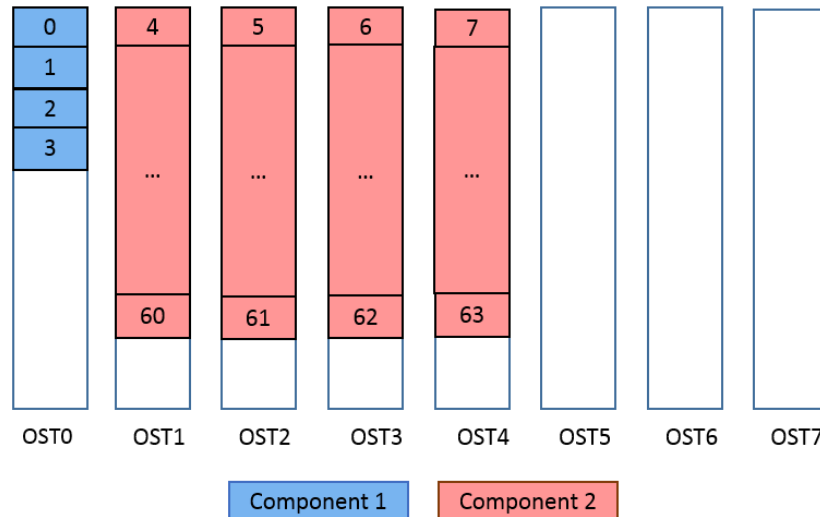

If you try to delete a non-last component, you will see the following error:

```
$ lfs setstripe -component-del -I 2 /mnt/testfs/del_comp
Delete component 0x2 from /mnt/testfs/del_comp failed. Invalid argument
error: setstripe: delete component of file '/mnt/testfs/del_comp' failed: Invalid
```

19.5.1.4. Set default PFL layout to an existing directory

Similar to create a PFL file, you can set default PFL layout to an existing directory. After that, all the files created will inherit this layout by default.

Command

```
lfs setstripe  
[--component-end|-E end1] [STRIPE_OPTIONS]  
[--component-end|-E end2] [STRIPE_OPTIONS] ... dirname
```

Example

```
$ mkdir /mnt/testfs/pfldir  
$ lfs setstripe -E 256M -c 1 -E 16G -c 4 -E -1 -S 4M -c -1 /mnt/testfs/pfldir
```

When you run `lfs getstripe`, you will see:

```
$ lfs getstripe /mnt/testfs/pfldir  
/mnt/testfs/pfldir  
lcm_layout_gen: 0  
lcm_entry_count: 3  
  lcme_id: N/A  
  lcme_flags: 0  
  lcme_extent.e_start: 0  
  lcme_extent.e_end: 268435456  
    stripe_count: 1    stripe_size: 1048576    stripe_offset: -1  
  lcme_id: N/A  
  lcme_flags: 0  
  lcme_extent.e_start: 268435456  
  lcme_extent.e_end: 17179869184  
    stripe_count: 4    stripe_size: 1048576    stripe_offset: -1  
  lcme_id: N/A  
  lcme_flags: 0  
  lcme_extent.e_start: 17179869184  
  lcme_extent.e_end: EOF  
    stripe_count: -1    stripe_size: 4194304    stripe_offset: -1
```

If you create a file under `/mnt/testfs/pfldir`, the layout of that file will inherit the layout from its parent directory:

```
$ touch /mnt/testfs/pfldir/pflfile  
$ lfs getstripe /mnt/testfs/pfldir/pflfile  
/mnt/testfs/pfldir/pflfile  
lcm_layout_gen: 2  
lcm_entry_count: 3  
  lcme_id: 1  
  lcme_flags: init  
  lcme_extent.e_start: 0  
  lcme_extent.e_end: 268435456  
    lmm_stripe_count: 1  
    lmm_stripe_size: 1048576  
    lmm_pattern: raid0  
    lmm_layout_gen: 0  
    lmm_stripe_offset: 1  
  lmm_objects:
```

```
- 0: { l_ost_idx: 1, l_fid: [0x100010000:0xa:0x0] }

lcme_id:          2
lcme_flags:       0
lcme_extent.e_start: 268435456
lcme_extent.e_end: 17179869184
  lmm_stripe_count: 4
  lmm_stripe_size: 1048576
  lmm_pattern:     raid0
  lmm_layout_gen: 0
  lmm_stripe_offset: -1

lcme_id:          3
lcme_flags:       0
lcme_extent.e_start: 17179869184
lcme_extent.e_end: EOF
  lmm_stripe_count: -1
  lmm_stripe_size: 4194304
  lmm_pattern:     raid0
  lmm_layout_gen: 0
  lmm_stripe_offset: -1
```

Note

`lfs setstripe --component-add/del` can't be run on a directory, because the default layout in directory is like a config, which can be arbitrarily changed by `lfs setstripe`, while the layout of a file may have data (OST objects) attached. If you want to delete the default layout in a directory, run `lfs setstripe -d dirname` to return the directory to the filesystem-wide defaults, like:

```
$ lfs setstripe -d /mnt/testfs/pfldir
$ lfs getstripe -d /mnt/testfs/pfldir
/mnt/testfs/pfldir
stripe_count: 1 stripe_size: 1048576 stripe_offset: -1
/mnt/testfs/pfldir/commonfile
lmm_stripe_count: 1
lmm_stripe_size: 1048576
lmm_pattern: 1
lmm_layout_gen: 0
lmm_stripe_offset: 0
  obdidx  objid  objid  group
        2         9         0x9         0
```

19.5.2. lfs migrate

`lfs migrate` commands are used to re-layout the data in the existing files with the new layout parameter by copying the data from the existing OST(s) to the new OST(s).

Command

```
lfs migrate [--component-end|-E comp_end] [STRIPE_OPTIONS] ...
filename
```

The difference between `migrate` and `setstripe` is that `migrate` is to re-layout the data in the existing files, while `setstripe` is to create new files with the specified layout.

Example

Case1. Migrate a normal one to a composite layout

```
$ lfs setstripe -c 1 -S 128K /mnt/testfs/norm_to_2comp
$ dd if=/dev/urandom of=/mnt/testfs/norm_to_2comp bs=1M count=5
$ lfs getstripe /mnt/testfs/norm_to_2comp --yaml
/mnt/testfs/norm_to_comp
lmm_stripe_count: 1
lmm_stripe_size: 131072
lmm_pattern: 1
lmm_layout_gen: 0
lmm_stripe_offset: 7
lmm_objects:
  - l_ost_idx: 7
    l_fid: 0x100070000:0x2:0x0
$ lfs migrate -E 1M -S 512K -c 1 -E -1 -S 1M -c 2 \
/mnt/testfs/norm_to_2comp
```

In this example, a 5MB size file with 1 stripe and 128K stripe size is migrated to a composite layout file with 2 components, illustrated in Figure 19.5, “Example: migrate normal to composite”.

Figure 19.5. Example: migrate normal to composite

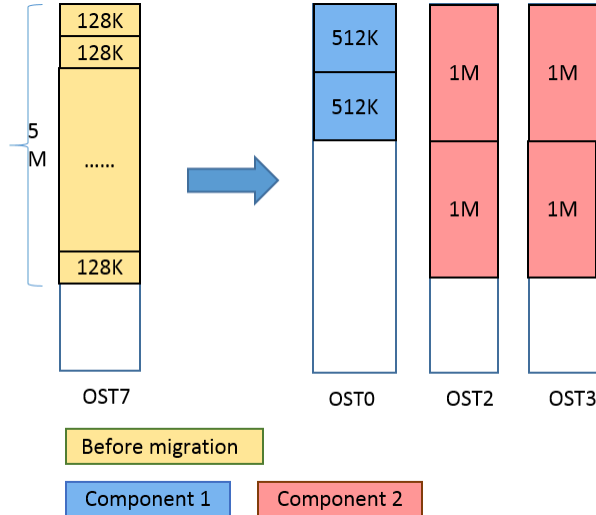

The stripe information after migration is like:

```
$ lfs getstripe /mnt/testfs/norm_to_2comp
/mnt/testfs/norm_to_2comp
lcm_layout_gen: 4
lcm_entry_count: 2
  lcme_id: 1
  lcme_flags: init
  lcme_extent.e_start: 0
  lcme_extent.e_end: 1048576
```

```

lmm_stripe_count: 1
lmm_stripe_size: 524288
lmm_pattern: 1
lmm_layout_gen: 0
lmm_stripe_offset: 0
lmm_objects:
- 0: { l_ost_idx: 0, l_fid: [0x100000000:0x2:0x0] }

lcme_id: 2
lcme_flags: init
lcme_extent.e_start: 1048576
lcme_extent.e_end: EOF
  lmm_stripe_count: 2
  lmm_stripe_size: 1048576
  lmm_pattern: 1
  lmm_layout_gen: 0
  lmm_stripe_offset: 2
  lmm_objects:
- 0: { l_ost_idx: 2, l_fid: [0x100020000:0x2:0x0] }
- 1: { l_ost_idx: 3, l_fid: [0x100030000:0x2:0x0] }

```

Case2. Migrate a composite layout to another composite layout

```

$ lfs setstripe -E 1M -S 512K -c 1 -E -1 -S 1M -c 2 \
/mnt/testfs/2comp_to_3comp
$ dd if=/dev/urandom of=/mnt/testfs/norm_to_2comp bs=1M count=5
$ lfs migrate -E 1M -S 1M -c 2 -E 4M -S 1M -c 2 -E -1 -S 3M -c 3 \
/mnt/testfs/2comp_to_3comp

```

In this example, a composite layout file with 2 components is migrated a composite layout file with 3 components. If we still use the example in case1, the migration process is illustrated in Figure 19.6, “Example: migrate composite to composite”.

Figure 19.6. Example: migrate composite to composite

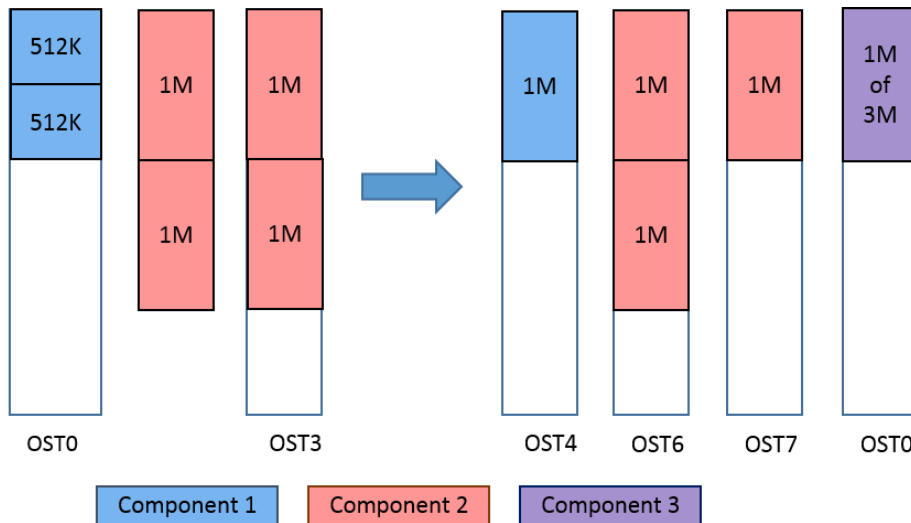

The stripe information is like:

```
$ lfs getstripe /mnt/testfs/2comp_to_3comp
/mnt/testfs/2comp_to_3comp
lcm_layout_gen: 6
lcm_entry_count: 3
  lcme_id: 1
  lcme_flags: init
  lcme_extent.e_start: 0
  lcme_extent.e_end: 1048576
    lmm_stripe_count: 2
    lmm_stripe_size: 1048576
    lmm_pattern: 1
    lmm_layout_gen: 0
    lmm_stripe_offset: 4
    lmm_objects:
      - 0: { l_ost_idx: 4, l_fid: [0x100040000:0x2:0x0] }
      - 1: { l_ost_idx: 5, l_fid: [0x100050000:0x2:0x0] }

  lcme_id: 2
  lcme_flags: init
  lcme_extent.e_start: 1048576
  lcme_extent.e_end: 4194304
    lmm_stripe_count: 2
    lmm_stripe_size: 1048576
    lmm_pattern: 1
    lmm_layout_gen: 0
    lmm_stripe_offset: 6
    lmm_objects:
      - 0: { l_ost_idx: 6, l_fid: [0x100060000:0x2:0x0] }
      - 1: { l_ost_idx: 7, l_fid: [0x100070000:0x3:0x0] }

  lcme_id: 3
  lcme_flags: init
  lcme_extent.e_start: 4194304
  lcme_extent.e_end: EOF
    lmm_stripe_count: 3
    lmm_stripe_size: 3145728
    lmm_pattern: 1
    lmm_layout_gen: 0
    lmm_stripe_offset: 0
    lmm_objects:
      - 0: { l_ost_idx: 0, l_fid: [0x100000000:0x3:0x0] }
      - 1: { l_ost_idx: 1, l_fid: [0x100010000:0x2:0x0] }
      - 2: { l_ost_idx: 2, l_fid: [0x100020000:0x3:0x0] }
```

Case3. Migrate a composite layout to a normal one

```
$ lfs migrate -E 1M -S 1M -c 2 -E 4M -S 1M -c 2 -E -1 -S 3M -c 3 \
/mnt/testfs/3comp_to_norm
$ dd if=/dev/urandom of=/mnt/testfs/norm_to_2comp bs=1M count=5
$ lfs migrate -c 2 -S 2M /mnt/testfs/3comp_to_normal
```

In this example, a composite file with 3 components is migrated to a normal file with 2 stripes and 2M stripe size. If we still use the example in Case2, the migration process is illustrated in Figure 19.7, “Example: migrate composite to normal”.

Figure 19.7. Example: migrate composite to normal

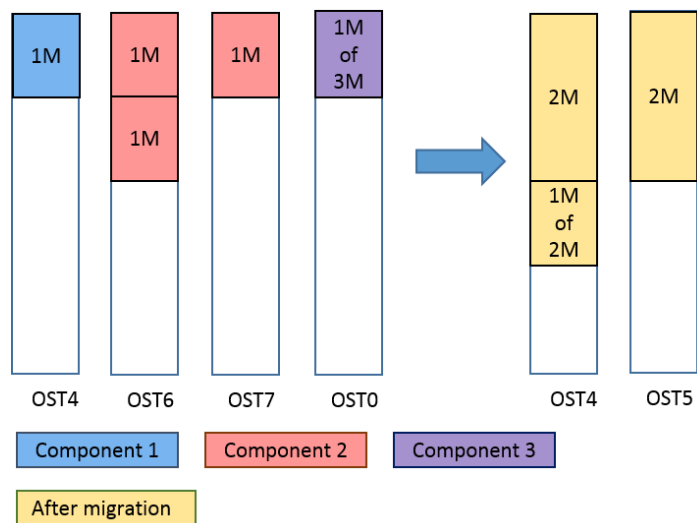

The stripe information is like:

```
$ lfs getstripe /mnt/testfs/3comp_to_norm --yaml
/mnt/testfs/3comp_to_norm
lmm_stripe_count: 2
lmm_stripe_size: 2097152
lmm_pattern: 1
lmm_layout_gen: 7
lmm_stripe_offset: 4
lmm_objects:
  - l_ost_idx: 4
    l_fid: 0x100040000:0x3:0x0
  - l_ost_idx: 5
    l_fid: 0x100050000:0x3:0x0
```

19.5.3. lfs getstripe

`lfs getstripe` commands can be used to list the striping/component information for a given PFL file. Here, only those parameters new for PFL files are shown.

Command

```
lfs getstripe
[--component-id|-I [comp_id]]
[--component-flags [comp_flags]]
[--component-count]
[--component-start [+][N][kMGTPe]]
[--component-end|-E [+][N][kMGTPe]]
dirname/filename
```

Example

Suppose we already have a composite file `/mnt/testfs/3comp`, created by the following command:

```
$ lfs setstripe -E 4M -c 1 -E 64M -c 4 -E -1 -c -1 -i 4 \
```

```
/mnt/testfs/3comp
```

And write some data

```
$ dd if=/dev/zero of=/mnt/testfs/3comp bs=1M count=5
```

Case1. List component ID and its related information

- List all the components ID

```
$ lfs getstripe -I /mnt/testfs/3comp
1
2
3
```

- List the detailed striping information of component ID=2

```
$ lfs getstripe -I2 /mnt/testfs/3comp
/mnt/testfs/3comp
lcm_layout_gen: 4
lcm_entry_count: 3
lcme_id: 2
lcme_flags: init
lcme_extent.e_start: 4194304
lcme_extent.e_end: 67108864
lmm_stripe_count: 4
lmm_stripe_size: 1048576
lmm_pattern: 1
lmm_layout_gen: 0
lmm_stripe_offset: 5
lmm_objects:
- 0: { l_ost_idx: 5, l_fid: [0x100050000:0x2:0x0] }
- 1: { l_ost_idx: 6, l_fid: [0x100060000:0x2:0x0] }
- 2: { l_ost_idx: 7, l_fid: [0x100070000:0x2:0x0] }
- 3: { l_ost_idx: 0, l_fid: [0x100000000:0x2:0x0] }
```

- List the stripe offset and stripe count of component ID=2

```
$ lfs getstripe -I2 -i -c /mnt/testfs/3comp
lmm_stripe_count: 4
lmm_stripe_offset: 5
```

Case2. List the component which contains the specified flag

- List the flag of each component

```
$ lfs getstripe --component-flag -I /mnt/testfs/3comp
lcme_id: 1
lcme_flags: init
lcme_id: 2
lcme_flags: init
lcme_id: 3
lcme_flags: 0
```

- List component(s) who is not instantiated

```
$ lfs getstripe --component-flags=^init /mnt/testfs/3comp
```

```
/mnt/testfs/3comp
lcm_layout_gen: 4
lcm_entry_count: 3
  lcme_id:          3
  lcme_flags:       0
  lcme_extent.e_start: 67108864
  lcme_extent.e_end: EOF
    lmm_stripe_count: -1
    lmm_stripe_size: 1048576
    lmm_pattern:      1
    lmm_layout_gen:  4
    lmm_stripe_offset: 4
```

Case3. List the total number of all the component(s)

- List the total number of all the components

```
$ lfs getstripe --component-count /mnt/testfs/3comp
3
```

Case4. List the component with the specified extent start or end positions

- List the start position in bytes of each component

```
$ lfs getstripe --component-start /mnt/testfs/3comp
0
4194304
67108864
```

- List the start position in bytes of component ID=3

```
$ lfs getstripe --component-start -I3 /mnt/testfs/3comp
67108864
```

- List the component with start = 64M

```
$ lfs getstripe --component-start=64M /mnt/testfs/3comp
/mnt/testfs/3comp
lcm_layout_gen: 4
lcm_entry_count: 3
  lcme_id:          3
  lcme_flags:       0
  lcme_extent.e_start: 67108864
  lcme_extent.e_end: EOF
    lmm_stripe_count: -1
    lmm_stripe_size: 1048576
    lmm_pattern:      1
    lmm_layout_gen:  4
    lmm_stripe_offset: 4
```

- List the component(s) with start > 5M

```
$ lfs getstripe --component-start=+5M /mnt/testfs/3comp
/mnt/testfs/3comp
lcm_layout_gen: 4
lcm_entry_count: 3
```

```
lcme_id:          3
lcme_flags:       0
lcme_extent.e_start: 67108864
lcme_extent.e_end: EOF
  lmm_stripe_count: -1
  lmm_stripe_size:  1048576
  lmm_pattern:     1
  lmm_layout_gen:  4
  lmm_stripe_offset: 4
```

- List the component(s) with start < 5M

```
$ lfs getstripe --component-start=-5M /mnt/testfs/3comp
/mnt/testfs/3comp
lcm_layout_gen:  4
lcm_entry_count: 3
  lcme_id:          1
  lcme_flags:       init
  lcme_extent.e_start: 0
  lcme_extent.e_end: 4194304
    lmm_stripe_count: 1
    lmm_stripe_size:  1048576
    lmm_pattern:     1
    lmm_layout_gen:  0
    lmm_stripe_offset: 4
    lmm_objects:
      - 0: { l_ost_idx: 4, l_fid: [0x100040000:0x2:0x0] }

  lcme_id:          2
  lcme_flags:       init
  lcme_extent.e_start: 4194304
  lcme_extent.e_end: 67108864
    lmm_stripe_count: 4
    lmm_stripe_size:  1048576
    lmm_pattern:     1
    lmm_layout_gen:  0
    lmm_stripe_offset: 5
    lmm_objects:
      - 0: { l_ost_idx: 5, l_fid: [0x100050000:0x2:0x0] }
      - 1: { l_ost_idx: 6, l_fid: [0x100060000:0x2:0x0] }
      - 2: { l_ost_idx: 7, l_fid: [0x100070000:0x2:0x0] }
      - 3: { l_ost_idx: 0, l_fid: [0x100000000:0x2:0x0] }
```

- List the component(s) with start > 3M and end < 70M

```
$ lfs getstripe --component-start=+3M --component-end=-70M \
/mnt/testfs/3comp
/mnt/testfs/3comp
lcm_layout_gen:  4
lcm_entry_count: 3
  lcme_id:          2
  lcme_flags:       init
  lcme_extent.e_start: 4194304
  lcme_extent.e_end: 67108864
    lmm_stripe_count: 4
```

```
lmm_stripe_size: 1048576
lmm_pattern: 1
lmm_layout_gen: 0
lmm_stripe_offset: 5
lmm_objects:
- 0: { l_ost_idx: 5, l_fid: [0x100050000:0x2:0x0] }
- 1: { l_ost_idx: 6, l_fid: [0x100060000:0x2:0x0] }
- 2: { l_ost_idx: 7, l_fid: [0x100070000:0x2:0x0] }
- 3: { l_ost_idx: 0, l_fid: [0x100000000:0x2:0x0] }
```

19.5.4. lfs find

`lfs find` commands can be used to search the directory tree rooted at the given directory or file name for the files that match the given PFL component parameters. Here, only those parameters new for PFL files are shown. Their usages are similar to `lfs getstripe` commands.

Command

```
lfs find directory/filename
[!] --component-count [+|=] comp_cnt
[!] --component-start [+|=] N[kMGTPe]
[!] --component-end|-E [+|=] N[kMGTPe]
[!] --component-flags=comp_flags
```

Note

If you use `--component-xxx` options, only the composite files will be searched; but if you use `! --component-xxx` options, all the files will be searched.

Example

We use the following directory and composite files to show how `lfs find` works.

```
$ mkdir /mnt/testfs/testdir
$ lfs setstripe -E 1M -E 10M -E eof /mnt/testfs/testdir/3comp
$ lfs setstripe -E 4M -E 20M -E 30M -E eof /mnt/testfs/testdir/4comp
$ mkdir -p /mnt/testfs/testdir/dir_3comp
$ lfs setstripe -E 6M -E 30M -E eof /mnt/testfs/testdir/dir_3comp
$ lfs setstripe -E 8M -E eof /mnt/testfs/testdir/dir_3comp/2comp
$ lfs setstripe -c 1 /mnt/testfs/testdir/dir_3comp/commonfile
```

Case1. Find the files that match the specified component count condition

Find the files under directory `/mnt/testfs/testdir` whose number of components is not equal to 3.

```
$ lfs find /mnt/testfs/testdir ! --component-count=3
/mnt/testfs/testdir
/mnt/testfs/testdir/4comp
/mnt/testfs/testdir/dir_3comp/2comp
/mnt/testfs/testdir/dir_3comp/commonfile
```

Case2. Find the files/dirs that match the specified component start/end condition

Find the file(s) under directory `/mnt/testfs/testdir` with component start = 4M and end < 70M

```
$ lfs find /mnt/testfs/testdir --component-start=4M -E -30M
```

```
/mnt/testfs/testdir/4comp
```

Case3. Find the files/dirs that match the specified component flag condition

Find the file(s) under directory /mnt/testfs/testdir whose component flags contain init

```
$ lfs find /mnt/testfs/testdir --component-flag=init  
/mnt/testfs/testdir/3comp  
/mnt/testfs/testdir/4comp  
/mnt/testfs/testdir/dir_3comp/2comp
```

Note

Since `lfs find` uses "!" to do negative search, we don't support `flag ^init` here.

Introduced in Lustre 2.13

19.6. Self-Extending Layout (SEL)

The Lustre Self-Extending Layout (SEL) feature is an extension of the Section 19.5, “Progressive File Layout(PFL)” feature, which allows the MDS to change the defined PFL layout dynamically. With this feature, the MDS monitors the used space on OSTs and swaps the OSTs for the current file when they are low on space. This avoids `ENOSPC` problems for SEL files when applications are writing to them.

Whereas PFL delays the instantiation of some components until an IO operation occurs on this region, SEL allows splitting such non-instantiated components in two parts: an “extendable” component and an “extension” component. The extendable component is a regular PFL component, covering just a part of the region, which is small originally. The extension (or SEL) component is a new component type which is always non-instantiated and unassigned, covering the other part of the region. When a write reaches this unassigned space, and the client calls the MDS to have it instantiated, the MDS makes a decision as to whether to grant additional space to the extendable component. The granted region moves from the head of the extension component to the tail of the extendable component, thus the extendable component grows and the SEL one is shortened. Therefore, it allows the file to continue on the same OSTs, or in the case where space is low on one of the current OSTs, to modify the layout to switch to a new component on new OSTs. In particular, it lets IO automatically spill over to a large HDD OST pool once a small SSD OST pool is getting low on space.

The default extension policy modifies the layout in the following ways:

1. Extension: continue on the same OSTs – used when not low on space on any of the OSTs of the current component; a particular extent is granted to the extendable component.
2. Spill over: switch to next component OSTs – it is used only for not the last component when *at least one* of the current OSTs is low on space; the whole region of the SEL component moves to the next component and the SEL component is removed in its turn.
3. Repeating: create a new component with the same layout but on free OSTs – it is used only for the last component when *at least one* of the current OSTs is low on space; a new component has the same layout but instantiated on different OSTs (from the same pool) which have enough space.
4. Forced extension: continue with the current component OSTs despite the low on space condition – it is used only for the last component when a repeating attempt detected low on space condition as well - spillover is impossible and there is no sense in the repeating.
5. Each spill event increments the `spill_hit` counter, which can be accessed with: `lctl lod.*.POOLNAME.spill_hit`

Note

The SEL feature does not require clients to understand the SEL format of already created files, only the MDS support is needed which is introduced in Lustre 2.13. However, old clients will have some limitations as the Lustre tools will not support it.

19.6.1. lfs setstripe

The `lfs setstripe` command is used to create files with composite layouts, as well as add or delete components to or from an existing file. It is extended to support SEL components.

19.6.1.1. Create a SEL file

Command

```
lfs setstripe  
[--component-end|-E end1] [STRIPE_OPTIONS] ... FILENAME
```

STRIPE OPTIONS:

```
--extension-size, --ext-size, -z <ext_size>
```

The `-z` option is added to specify the size of the region which is granted to the extendable component on each iteration. While declaring any component, this option turns the declared component to a pair of components: extendable and extension ones.

Example

The following command creates 2 pairs of extendable and extension components:

```
# lfs setstripe -E 1G -z 64M -E -1 -z 256M /mnt/lustre/file
```

Figure 19.8. Example: create a SEL file

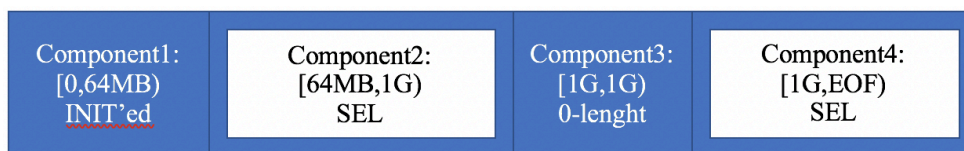

Note

As usual, only the first PFL component is instantiated at the creation time, thus it is immediately extended to the extension size (64M for the first component), whereas the third component is left zero-length.

```
# lfs getstripe /mnt/lustre/file  
/mnt/lustre/file  
lcm_layout_gen: 4  
lcm_mirror_count: 1  
lcm_entry_count: 4  
  lcme_id: 1  
  lcme_mirror_id: 0  
  lcme_flags: init  
  lcme_extent.e_start: 0  
  lcme_extent.e_end: 67108864  
  lmm_stripe_count: 1
```

```
lmm_stripe_size: 1048576
lmm_pattern: raid0
lmm_layout_gen: 0
lmm_stripe_offset: 0
lmm_objects:
- 0: { l_ost_idx: 0, l_fid: [0x100000000:0x5:0x0] }

lcme_id: 2
lcme_mirror_id: 0
lcme_flags: extension
lcme_extent.e_start: 67108864
lcme_extent.e_end: 1073741824
  lmm_stripe_count: 0
  lmm_extension_size: 67108864
  lmm_pattern: raid0
  lmm_layout_gen: 0
  lmm_stripe_offset: -1

lcme_id: 3
lcme_mirror_id: 0
lcme_flags: 0
lcme_extent.e_start: 1073741824
lcme_extent.e_end: 1073741824
  lmm_stripe_count: 1
  lmm_stripe_size: 1048576
  lmm_pattern: raid0
  lmm_layout_gen: 0
  lmm_stripe_offset: -1

lcme_id: 4
lcme_mirror_id: 0
lcme_flags: extension
lcme_extent.e_start: 1073741824
lcme_extent.e_end: EOF
  lmm_stripe_count: 0
  lmm_extension_size: 268435456
  lmm_pattern: raid0
  lmm_layout_gen: 0
  lmm_stripe_offset: -1
```

19.6.1.2. Create a SEL layout template

Similar to PFL, it is possible to set a SEL layout template to a directory. After that, all the files created under it will inherit this layout by default.

```
# lfs setstripe -E 1G -z 64M -E -1 -z 256M /mnt/lustre/dir
# ./lustre/utils/lfs getstripe /mnt/lustre/dir
/mnt/lustre/dir
lcm_layout_gen: 0
lcm_mirror_count: 1
lcm_entry_count: 4
lcme_id: N/A
lcme_mirror_id: N/A
lcme_flags: 0
```



```
lcme_extent.e_start: 0
lcme_extent.e_end: 67108864
  stripe_count: 1      stripe_size: 1048576      pattern: raid0

lcme_id: N/A
lcme_mirror_id: N/A
lcme_flags: extension
lcme_extent.e_start: 67108864
lcme_extent.e_end: 1073741824
  stripe_count: 1      extension_size: 67108864      pattern: raid0

lcme_id: N/A
lcme_mirror_id: N/A
lcme_flags: 0
lcme_extent.e_start: 1073741824
lcme_extent.e_end: 1073741824
  stripe_count: 1      stripe_size: 1048576      pattern: raid0

lcme_id: N/A
lcme_mirror_id: N/A
lcme_flags: extension
lcme_extent.e_start: 1073741824
lcme_extent.e_end: EOF
  stripe_count: 1      extension_size: 268435456      pattern: raid0
```

19.6.2. lfs getstripe

`lfs getstripe` commands can be used to list the striping/component information for a given SEL file. Here, only those parameters new for SEL files are shown.

Command

```
lfs getstripe
[--extension-size|--ext-size|-z] filename
```

The `-z` option is added to print the extension size in bytes. For composite files this is the extension size of the first extension component. If a particular component is identified by other options (`--component-id`, `--component-start`, etc...), this component extension size is printed.

Example 1: List a SEL component information

Suppose we already have a composite file `/mnt/lustre/file`, created by the following command:

```
# lfs setstripe -E 1G -z 64M -E -1 -z 256M /mnt/lustre/file
```

The 2nd component could be listed with the following command:

```
# lfs getstripe -I2 /mnt/lustre/file
/mnt/lustre/file
  lcm_layout_gen: 4
  lcm_mirror_count: 1
  lcm_entry_count: 4
    lcme_id: 2
    lcme_mirror_id: 0
    lcme_flags: extension
```

```
lcme_extent.e_start: 67108864
lcme_extent.e_end: 1073741824
lmm_stripe_count: 0
lmm_extension_size: 67108864
lmm_pattern: raid0
lmm_layout_gen: 0
lmm_stripe_offset: -1
```

Note

As you can see the SEL components are marked by the `extension` flag and `lmm_extension_size` field keeps the specified extension size.

Example 2: List the extension size

Having the same file as in the above example, the extension size of the second component could be listed with:

```
# lfs getstripe -z -I2 /mnt/lustre/file
67108864
```

Example 3: Extension

Having the same file as in the above example, suppose there is a write which crosses the end of the first component (64M), and then another write another write which crosses the end of the first component (128M) again, the layout changes as following:

Figure 19.9. Example: an extension of a SEL file

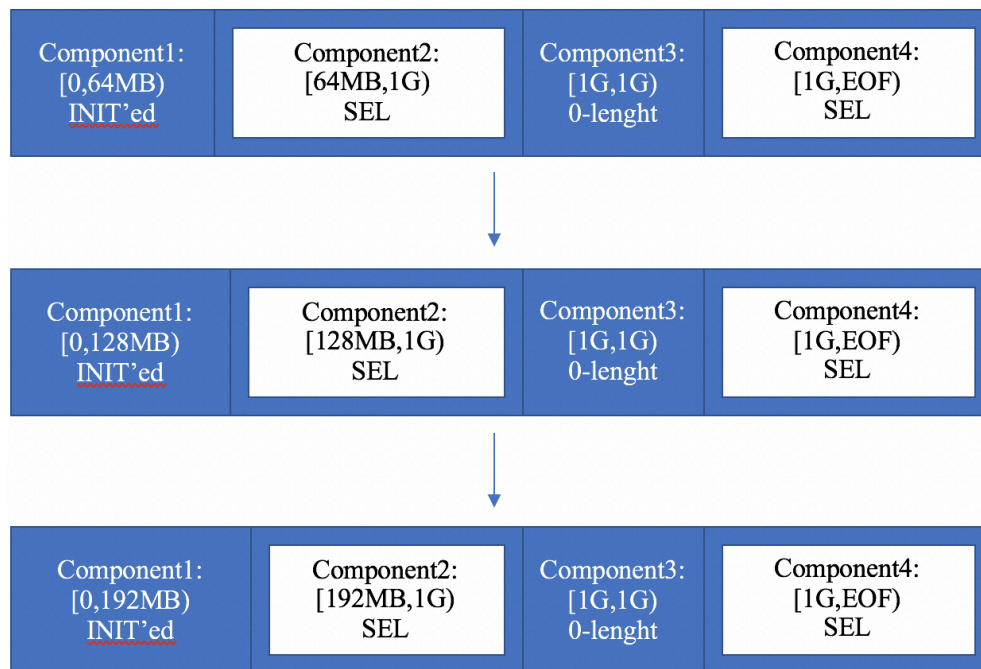

The layout can be printed out by the following command:

```
# lfs getstripe /mnt/lustre/file
/mnt/lustre/file
```

```
lcm_layout_gen: 6
lcm_mirror_count: 1
lcm_entry_count: 4
  lcme_id: 1
  lcme_mirror_id: 0
  lcme_flags: init
  lcme_extent.e_start: 0
  lcme_extent.e_end: 201326592
    lmm_stripe_count: 1
    lmm_stripe_size: 1048576
    lmm_pattern: raid0
    lmm_layout_gen: 0
    lmm_stripe_offset: 0
    lmm_objects:
      - 0: { l_ost_idx: 0, l_fid: [0x100000000:0x5:0x0] }

  lcme_id: 2
  lcme_mirror_id: 0
  lcme_flags: extension
  lcme_extent.e_start: 201326592
  lcme_extent.e_end: 1073741824
    lmm_stripe_count: 0
    lmm_extension_size: 67108864
    lmm_pattern: raid0
    lmm_layout_gen: 0
    lmm_stripe_offset: -1

  lcme_id: 3
  lcme_mirror_id: 0
  lcme_flags: 0
  lcme_extent.e_start: 1073741824
  lcme_extent.e_end: 1073741824
    lmm_stripe_count: 1
    lmm_stripe_size: 1048576
    lmm_pattern: raid0
    lmm_layout_gen: 0
    lmm_stripe_offset: -1

  lcme_id: 4
  lcme_mirror_id: 0
  lcme_flags: extension
  lcme_extent.e_start: 1073741824
  lcme_extent.e_end: EOF
    lmm_stripe_count: 0
    lmm_extension_size: 268435456
    lmm_pattern: raid0
    lmm_layout_gen: 0
    lmm_stripe_offset: -1
```

Example 4: Spillover

In case where OST0 is low on space and an IO happens to a SEL component, a spillover happens: the full region of the SEL component is added to the next component, e.g. in the example above the next layout modification will look like:

Figure 19.10. Example: a spillover in a SEL file

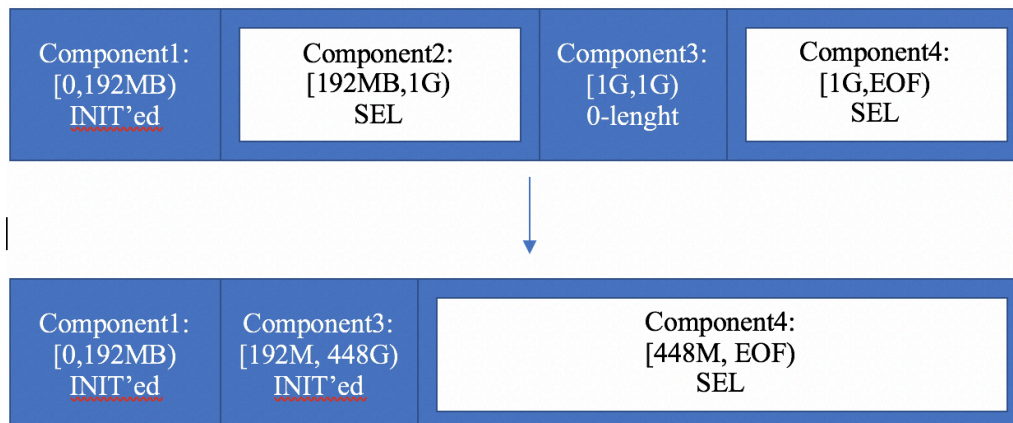

Note

Despite the fact the third component was [1G, 1G] originally, while it is not instantiated, instead of getting extended backward, it is moved backward to the start of the previous SEL component (192M) and extended on its extension size (256M) from that position, thus it becomes [192M, 448M].

```
# lfs getstripe /mnt/lustre/file
/mnt/lustre/file
lcm_layout_gen: 7
lcm_mirror_count: 1
lcm_entry_count: 3
  lcme_id: 1
  lcme_mirror_id: 0
  lcme_flags: init
  lcme_extent.e_start: 0
  lcme_extent.e_end: 201326592
    lmm_stripe_count: 1
    lmm_stripe_size: 1048576
    lmm_pattern: raid0
    lmm_layout_gen: 0
    lmm_stripe_offset: 0
    lmm_objects:
      - 0: { l_ost_idx: 0, l_fid: [0x100000000:0x5:0x0] }

  lcme_id: 3
  lcme_mirror_id: 0
  lcme_flags: init
  lcme_extent.e_start: 201326592
  lcme_extent.e_end: 469762048
    lmm_stripe_count: 1
    lmm_stripe_size: 1048576
    lmm_pattern: raid0
    lmm_layout_gen: 0
    lmm_stripe_offset: 1
    lmm_objects:
      - 0: { l_ost_idx: 1, l_fid: [0x100010000:0x8:0x0] }
```

```
lcme_id: 4
lcme_mirror_id: 0
lcme_flags: extension
lcme_extent.e_start: 469762048
lcme_extent.e_end: EOF
  lmm_stripe_count: 0
  lmm_extension_size: 268435456
  lmm_pattern: raid0
  lmm_layout_gen: 0
  lmm_stripe_offset: -1
```

Example 5: Repeating

Suppose in the example above, OST0 got enough free space back but OST1 is low on space, the following write to the last SEL component leads to a new component allocation before the SEL component, which repeats the previous component layout but instantiated on free OSTs:

Figure 19.11. Example: repeat a SEL component

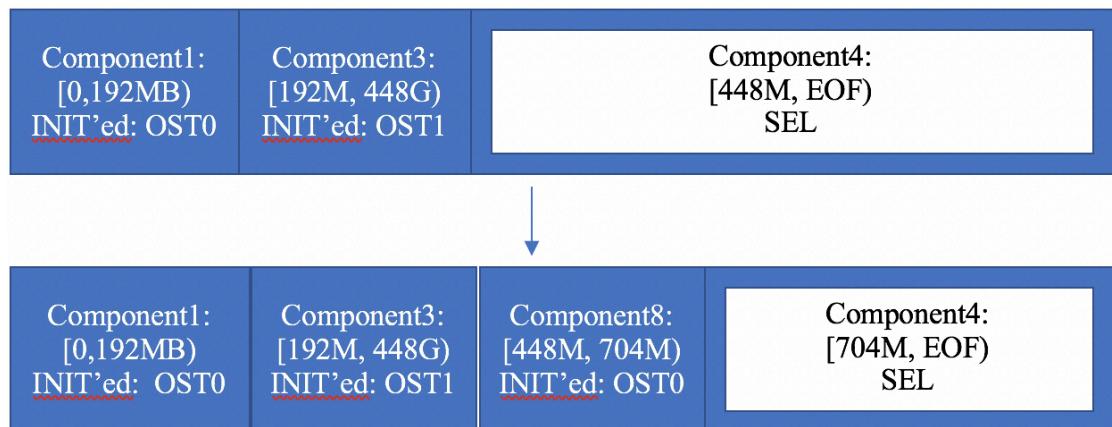

```
# lfs getstripe /mnt/lustre/file
/mnt/lustre/file
lcm_layout_gen: 9
lcm_mirror_count: 1
lcm_entry_count: 4
  lcme_id: 1
  lcme_mirror_id: 0
  lcme_flags: init
  lcme_extent.e_start: 0
  lcme_extent.e_end: 201326592
    lmm_stripe_count: 1
    lmm_stripe_size: 1048576
    lmm_pattern: raid0
    lmm_layout_gen: 0
    lmm_stripe_offset: 0
    lmm_objects:
      - 0: { l_ost_idx: 0, l_fid: [0x100000000:0x5:0x0] }

lcme_id: 3
lcme_mirror_id: 0
lcme_flags: init
```

```

lcme_extent.e_start: 201326592
lcme_extent.e_end: 469762048
  lmm_stripe_count: 1
  lmm_stripe_size: 1048576
  lmm_pattern: raid0
  lmm_layout_gen: 0
  lmm_stripe_offset: 1
  lmm_objects:
  - 0: { l_ost_idx: 1, l_fid: [0x100010000:0x8:0x0] }

lcme_id: 8
lcme_mirror_id: 0
lcme_flags: init
lcme_extent.e_start: 469762048
lcme_extent.e_end: 738197504
  lmm_stripe_count: 1
  lmm_stripe_size: 1048576
  lmm_pattern: raid0
  lmm_layout_gen: 65535
  lmm_stripe_offset: 0
  lmm_objects:
  - 0: { l_ost_idx: 0, l_fid: [0x100000000:0x6:0x0] }

lcme_id: 4
lcme_mirror_id: 0
lcme_flags: extension
lcme_extent.e_start: 738197504
lcme_extent.e_end: EOF
  lmm_stripe_count: 0
  lmm_extension_size: 268435456
  lmm_pattern: raid0
  lmm_layout_gen: 0
  lmm_stripe_offset: -1

```

Example 6: Forced extension

Suppose in the example above, both OST0 and OST1 are low on space, the following write to the last SEL component will behave as an extension as there is no sense to repeat.

Figure 19.12. Example: forced extension in a SEL file

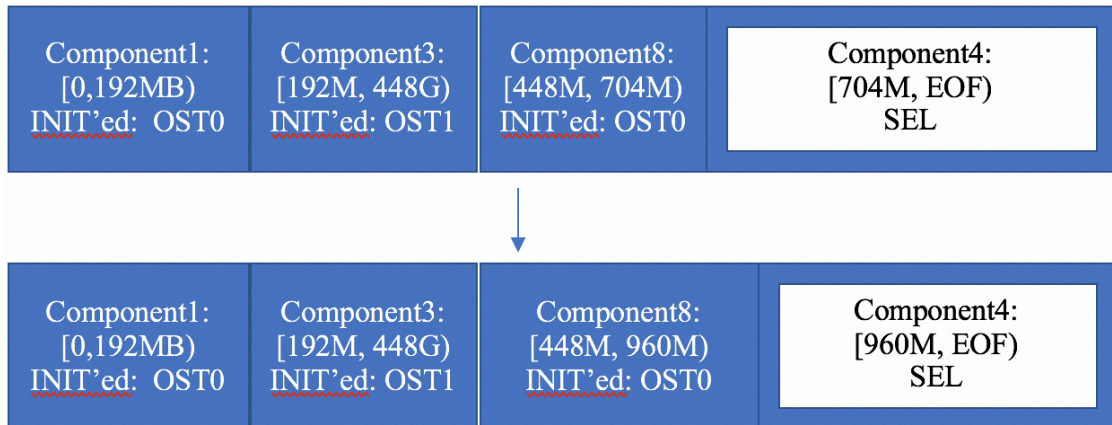

```
# lfs getstripe /mnt/lustre/file
/mnt/lustre/file
lcm_layout_gen: 11
lcm_mirror_count: 1
lcm_entry_count: 4
  lcme_id: 1
  lcme_mirror_id: 0
  lcme_flags: init
  lcme_extent.e_start: 0
  lcme_extent.e_end: 201326592
    lmm_stripe_count: 1
    lmm_stripe_size: 1048576
    lmm_pattern: raid0
    lmm_layout_gen: 0
    lmm_stripe_offset: 0
    lmm_objects:
      - 0: { l_ost_idx: 0, l_fid: [0x100000000:0x5:0x0] }

  lcme_id: 3
  lcme_mirror_id: 0
  lcme_flags: init
  lcme_extent.e_start: 201326592
  lcme_extent.e_end: 469762048
    lmm_stripe_count: 1
    lmm_stripe_size: 1048576
    lmm_pattern: raid0
    lmm_layout_gen: 0
    lmm_stripe_offset: 1
    lmm_objects:
      - 0: { l_ost_idx: 1, l_fid: [0x100010000:0x8:0x0] }

  lcme_id: 8
  lcme_mirror_id: 0
  lcme_flags: init
  lcme_extent.e_start: 469762048
  lcme_extent.e_end: 1006632960
    lmm_stripe_count: 1
    lmm_stripe_size: 1048576
    lmm_pattern: raid0
    lmm_layout_gen: 65535
    lmm_stripe_offset: 0
    lmm_objects:
      - 0: { l_ost_idx: 0, l_fid: [0x100000000:0x6:0x0] }

  lcme_id: 4
  lcme_mirror_id: 0
  lcme_flags: extension
  lcme_extent.e_start: 1006632960
  lcme_extent.e_end: EOF
    lmm_stripe_count: 0
    lmm_extension_size: 268435456
    lmm_pattern: raid0
    lmm_layout_gen: 0
    lmm_stripe_offset: -1
```

19.6.3. lfs find

`lfs find` commands can be used to search for the files that match the given SEL component parameters. Here, only those parameters new for the SEL files are shown.

```
lfs find
[[!]] --extension-size|--ext-size|-z [+ -]ext-size[KMG]
[[!]] --component-flags=extension]
```

The `-z` option is added to specify the extension size to search for. The files which have any component with the extension size matched the given criteria are printed out. As always “+” and “-“ signs are allowed to specify the least and the most size.

A new extension component flag is added. Only files which have at least one SEL component are printed.

Note

The negative search for flags searches the files which **have** a non-SEL component (not files which **do not have** any SEL component).

Example

```
# lfs setstripe --extension-size 64M -c 1 -E -1 /mnt/lustre/file

# lfs find --comp-flags extension /mnt/lustre/*
/mnt/lustre/file

# lfs find ! --comp-flags extension /mnt/lustre/*
/mnt/lustre/file

# lfs find -z 64M /mnt/lustre/*
/mnt/lustre/file

# lfs find -z +64M /mnt/lustre/*

# lfs find -z -64M /mnt/lustre/*

# lfs find -z +63M /mnt/lustre/*
/mnt/lustre/file

# lfs find -z -65M /mnt/lustre/*
/mnt/lustre/file

# lfs find -z 65M /mnt/lustre/*

# lfs find ! -z 64M /mnt/lustre/*

# lfs find ! -z +64M /mnt/lustre/*
/mnt/lustre/file

# lfs find ! -z -64M /mnt/lustre/*
/mnt/lustre/file
```



```
# lfs find ! -z +63M /mnt/lustre/*  
  
# lfs find ! -z -65M /mnt/lustre/*  
  
# lfs find ! -z 65M /mnt/lustre/*  
/mnt/lustre/file
```

Introduced in Lustre 2.13

19.7. Foreign Layout

The Lustre Foreign Layout feature is an extension of both the LOV and LMV formats which allows the creation of empty files and directories with the necessary specifications to point to corresponding objects outside from Lustre namespace.

The new LOV/LMV foreign internal format can be represented as:

Figure 19.13. LOV/LMV foreign format



19.7.1. lfs set[dir]stripe

The `lfs set[dir]stripe` commands are used to create files or directories with foreign layouts, by calling the corresponding API, itself invoking the appropriate `ioctl()`.

19.7.1.1. Create a Foreign file/dir

Command

```
lfs set[dir]stripe \  
--foreign[=<foreign_type>] --xattr|-x <layout_string> \  
[--flags <hex_bitmask>] [--mode <mode_bits>] \  
{file,dir}name
```

Both the `--foreign` and `--xattr|-x` options are mandatory. The `<foreign_type>` (default is "none", meaning no special behavior), and both `--flags` and `--mode` (default is 0666) options are optional.

Example

The following command creates a foreign file of "none" type and with "foo@bar" LOV content and specific mode and flags:

```
# lfs setstripe --foreign=none --flags=0xda08 --mode=0640 \  
--xattr=foo@bar /mnt/lustre/file
```

Figure 19.14. Example: create a foreign file

Foreign LOV/LMV magic: 0x0bd70bd0	Length of free string: 7	Foreign type: 0 (none)	Foreign flags: 0x0000da08	Free string (char []): « foo@bar »
--------------------------------------	-----------------------------	---------------------------	------------------------------	---------------------------------------

19.7.2. `lfs get[dir]stripe`

`lfs get[dir]stripe` commands can be used to retrieve foreign LOV/LMV informations and content.

Command

```
lfs get[dir]stripe [-v] filename
```

List foreign layout information

Suppose we already have a foreign file `/mnt/lustre/file`, created by the following command:

```
# lfs setstripe --foreign=none --flags=0xda08 --mode=0640 \  
--xattr=foo@bar /mnt/lustre/file
```

The full foreign layout informations can be listed using the following command:

```
# lfs getstripe -v /mnt/lustre/file  
/mnt/lustre/file  
lfm_magic: 0x0BD70BD0  
lfm_length: 7  
lfm_type: none  
lfm_flags: 0x0000DA08  
lfm_value: foo@bar
```

Note

As you can see the `lfm_length` field value is the characters number in the variable length `lfm_value` field.

19.7.3. `lfs find`

`lfs find` commands can be used to search for all the foreign files/directories or those that match the given selection parameters.

```
lfs find  
[!] --foreign[=<foreign_type>]
```

The `--foreign[=<foreign_type>]` option has been added to specify that all [!,but not] files and/or directories with a foreign layout [and [!,but not] of `<foreign_type>`] will be retrieved.

Example

```
# lfs setstripe --foreign=none --xattr=foo@bar /mnt/lustre/file
```

```
# touch /mnt/lustre/file2

# lfs find --foreign /mnt/lustre/*
/mnt/lustre/file

# lfs find ! --foreign /mnt/lustre/*
/mnt/lustre/file2

# lfs find --foreign=none /mnt/lustre/*
/mnt/lustre/file
```

19.8. Managing Free Space

To optimize file system performance, the MDT assigns file stripes to OSTs based on two allocation algorithms. The *round-robin* allocator gives preference to location (spreading out stripes across OSSs to increase network bandwidth utilization) and the weighted allocator gives preference to available space (balancing loads across OSTs). Threshold and weighting factors for these two algorithms can be adjusted by the user. The MDT reserves 0.1 percent of total OST space and 32 inodes for each OST. The MDT stops object allocation for the OST if available space is less than reserved or the OST has fewer than 32 free inodes. The MDT starts object allocation when available space is twice as big as the reserved space and the OST has more than 64 free inodes. Note, clients could append existing files no matter what object allocation state is.

Introduced in Lustre 2.9

The reserved space for each OST can be adjusted by the user. Use the `lctl set_param` command, for example the next command reserve 1GB space for all OSTs.

```
lctl set_param -P osp.*.reserved_mb_low=1024
```

This section describes how to check available free space on disks and how free space is allocated. It then describes how to set the threshold and weighting factors for the allocation algorithms.

19.8.1. Checking File System Free Space

Free space is an important consideration in assigning file stripes. The `lfs df` command can be used to show available disk space on the mounted Lustre file system and space consumption per OST. If multiple Lustre file systems are mounted, a path may be specified, but is not required. Options to the `lfs df` command are shown below.

Option	Description
<code>-h, --human-readable</code>	Displays sizes in human readable format (for example: 1K, 234M, 5G) using base-2 (binary) values (i.e. 1G = 1024M).
<code>-H, --si</code>	Like <code>-h</code> , this displays counts in human readable format, but using base-10 (decimal) values (i.e. 1G = 1000M).
<code>-i, --inodes</code>	Lists inodes instead of block usage.

Option	Description
<code>-l, --lazy</code>	Do not attempt to contact any OST or MDT not currently connected to the client. This avoids blocking the <code>lfs df</code> output if a target is offline or unreachable, and only returns the space on OSTs that can currently be accessed.
<code>-p, --pool</code>	Limit the usage to report only OSTs that are in the specified <code>pool</code> . If multiple Lustre filesystems are mounted, list the OSTs in <code>pool</code> for each filesystem, or limit the display to only a pool for a specific filesystem if <code>fsname.pool</code> is given. Specifying both <code>fsname</code> and <code>pool</code> is equivalent to providing a specific mountpoint.
<code>-v, --verbose</code>	Display verbose status of MDTs and OSTs. This may include one or more optional flags at the end of each line.

`lfs df` may also report additional target status as the last column in the display, if there are issues with that target. Target states include:

- **D:** OST/MDT is Degraded. The target has a failed drive in the RAID device, or is undergoing RAID reconstruction. This state is marked on the server automatically for ZFS targets via `zed`, or a (user-supplied) script that monitors the target device and sets `"lctl set_param obdfilter.target.degraded=1"` on the OST. This target will be avoided for new allocations, but will still be used to read existing files located there or if there are not enough non-degraded OSTs to make up a widely-striped file.
- **R:** OST/MDT is Read-only. The target filesystem is marked read-only due to filesystem corruption detected by `ldiskfs` or ZFS. No modifications are allowed on this OST, and it needs to be unmounted and `e2fsck` or `zpool scrub` run to repair the underlying filesystem.
- **N:** OST/MDT is No-precreate. The target is configured to deny object precreation set by `"lctl set_param obdfilter.target.no_precreate=1"` parameter or the `"-o no_precreate"` mount option. This may be done to add an OST to the filesystem without allowing objects to be allocated on it yet, or for other reasons.
- **S:** OST/MDT is out of Space. The target filesystem has less than the minimum required free space and will not be used for new object allocations until it has more free space.
- **I:** OST/MDT is out of Inodes. The target filesystem has less than the minimum required free inodes and will not be used for new object allocations until it has more free inodes.
- **f:** OST/MDT is on flash. The target filesystem is using a flash (non-rotational) storage device. This is normally detected from the underlying Linux block device, but can be set manually with `"lctl set_param osd-*.*.nonrotational=1"` on the respective OSTs. This lower-case status is only shown in conjunction with the `-v` option, since it is not an error condition.

Note

The `df -i` and `lfs df -i` commands show the *minimum* number of inodes that can be created in the file system at the current time. If the total number of objects available across all of the OSTs is smaller than those available on the MDT(s), taking into account the default file striping, then `df -i` will also report a smaller number of inodes than could be created. Running `lfs df -i` will report the actual number of inodes that are free on each target.

For ZFS file systems, the number of inodes that can be created is dynamic and depends on the free space in the file system. The Free and Total inode counts reported for a ZFS file system are only an estimate based on the current usage for each target. The Used inode count is the actual number of inodes used by the file system.

Examples

```
client$ lfs df
UID                1K-blocks      Used Available Use% Mounted on
testfs-OST0000_UID  9174328      1020024   8154304  11% /mnt/lustre[MDT:0]
testfs-OST0000_UID  94181368     56330708  37850660  59% /mnt/lustre[OST:0]
testfs-OST0001_UID  94181368     56385748  37795620  59% /mnt/lustre[OST:1]
testfs-OST0002_UID  94181368     54352012  39829356  57% /mnt/lustre[OST:2]
filesystem summary: 282544104   167068468  39829356  57% /mnt/lustre

[client1] $ lfs df -hv
UID                bytes          Used Available Use% Mounted on
testfs-MDT0000_UID  8.7G          996.1M       7.8G  11% /mnt/lustre[MDT:0]
testfs-OST0000_UID  89.8G         53.7G        36.1G  59% /mnt/lustre[OST:0] f
testfs-OST0001_UID  89.8G         53.8G        36.0G  59% /mnt/lustre[OST:1] f
testfs-OST0002_UID  89.8G         51.8G        38.0G  57% /mnt/lustre[OST:2] f
filesystem summary: 269.5G         159.3G       110.1G  59% /mnt/lustre

[client1] $ lfs df -iH
UID                Inodes         IUsed      IFree IUse% Mounted on
testfs-MDT0000_UID  2.21M         41.9k      2.17M   1% /mnt/lustre[MDT:0]
testfs-OST0000_UID  737.3k        12.1k      725.1k   1% /mnt/lustre[OST:0]
testfs-OST0001_UID  737.3k        12.2k      725.0k   1% /mnt/lustre[OST:1]
testfs-OST0002_UID  737.3k        12.2k      725.0k   1% /mnt/lustre[OST:2]
filesystem summary:  2.21M         41.9k      2.17M   1% /mnt/lustre[OST:2]
```

19.8.2. Stripe Allocation Methods

Two stripe allocation methods are provided:

- **Round-robin allocator** - When the OSTs have approximately the same amount of free space, the round-robin allocator alternates stripes between OSTs on different OSSs, so the OST used for stripe 0 of each file is evenly distributed among OSTs, regardless of the stripe count. In a simple example with eight OSTs numbered 0-7, objects would be allocated like this:

```
File 1: OST1, OST2, OST3, OST4
File 2: OST5, OST6, OST7
File 3: OST0, OST1, OST2, OST3, OST4, OST5
File 4: OST6, OST7, OST0
```

Here are several more sample round-robin stripe orders (each letter represents a different OST on a single OSS):

3: AAA	One 3-OST OSS
3x3: ABABAB	Two 3-OST OSSs
3x4: BBABABA	One 3-OST OSS (A) and one 4-OST OSS (B)
3x5: BBABBABA	One 3-OST OSS (A) and one 5-OST OSS (B)
3x3x3: ABCABCABC	Three 3-OST OSSs

- **Weighted allocator** - When the free space difference between the OSTs becomes significant, the weighting algorithm is used to influence OST ordering based on size (amount of free space available on each OST) and location (stripes evenly distributed across OSTs). The weighted allocator fills the emptier OSTs faster, but uses a weighted random algorithm, so the OST with the most free space is not necessarily chosen each time.

The allocation method is determined by the amount of free-space imbalance on the OSTs. When free space is relatively balanced across OSTs, the faster round-robin allocator is used, which maximizes network balancing. The weighted allocator is used when any two OSTs are out of balance by more than the specified threshold (17% by default). The threshold between the two allocation methods is defined by the `qos_threshold_rr` parameter.

To temporarily set the `qos_threshold_rr` to 25, enter the following on each MDS:

```
mgs# lctl set_param lod.fsname*.qos_threshold_rr=25
```

19.8.3. Adjusting the Weighting Between Free Space and Location

The weighting priority used by the weighted allocator is set by the `qos_prio_free` parameter. Increasing the value of `qos_prio_free` puts more weighting on the amount of free space available on each OST and less on how stripes are distributed across OSTs. The default value is 91 (percent). When the free space priority is set to 100 (percent), weighting is based entirely on free space and location is no longer used by the striping algorithm.

To permanently change the allocator weighting to 100, enter this command on the MGS:

```
lctl conf_param fsname-MDT0000-*.lod.qos_prio_free=100
```

Note

When `qos_prio_free` is set to 100, a weighted random algorithm is still used to assign stripes, so, for example, if OST2 has twice as much free space as OST1, OST2 is twice as likely to be used, but it is not guaranteed to be used.

19.9. Lustre Striping Internals

Individual files can only be striped over a finite number of OSTs, based on the maximum size of the attributes that can be stored on the MDT. If the MDT is `ldiskfs`-based without the `ea_inode` feature, a file can be striped across at most 160 OSTs. With `ZFS`-based MDTs, or if the `ea_inode` feature is enabled for an `ldiskfs`-based MDT, a file can be striped across up to 2000 OSTs.

Lustre inodes use an extended attribute to record on which OST each object is located, and the identifier each object on that OST. The size of the extended attribute is a function of the number of stripes.

If using an `ldiskfs`-based MDT, the maximum number of OSTs over which files can be striped can be raised to 2000 by enabling the `ea_inode` feature on the MDT:

```
tune2fs -O ea_inode /dev/mdtdev
```

Note

Since Lustre 2.13 the `ea_inode` feature is enabled by default on all newly formatted `ldiskfs` MDT filesystems.

Note

The maximum stripe count for a single file does not limit the maximum number of OSTs that are in the filesystem as a whole, only the maximum possible size and maximum aggregate bandwidth for the file.

Chapter 20. Data on MDT (DoM)

This chapter describes Data on MDT (DoM).

20.1. Introduction to Data on MDT (DoM)

The Lustre Data on MDT (DoM) feature improves small file IO by placing small files directly on the MDT, and also improves large file IO by avoiding the OST being affected by small random IO that can cause device seeking and hurt the streaming IO performance. Therefore, users can expect more consistent performance for both small file IO and mixed IO patterns.

The layout of a DoM file is stored on disk as a composite layout and is a special case of Progressive File Layout (PFL). Please see Section 19.5, “Progressive File Layout(PFL)” for more information on PFL. For DoM files, the file layout is composed of the component of the file, which is placed on an MDT, and the rest of components are placed on OSTs, if needed. The first component is placed on the MDT in the MDT object data blocks. This component always has one stripe with size equal to the component size. Such a component with an MDT layout can be only the first component in composite layout. The rest of components are placed over OSTs as usual with a RAID0 layout. The OST components are not instantiated until a client writes or truncates the file beyond the size of the MDT component.

20.2. User Commands

Lustre provides the `lfs setstripe` command for users to create DoM files. Also, as usual, `lfs getstripe` command can be used to list the striping/component information for a given file, while `lfs find` command can be used to search the directory tree rooted at the given directory or file name for the files that match the given DoM component parameters, e.g. layout type.

20.2.1. `lfs setstripe` for DoM files

The `lfs setstripe` command is used to create DoM files.

20.2.1.1. Command

```
lfs setstripe --component-end|-E end1 --layout|-L mdt \  
  [--component-end|-E end2 [STRIPE_OPTIONS] ...] <filename>
```

The command above creates a file with the special composite layout, which defines the first component as an MDT component. The MDT component must start from offset 0 and ends at `end1`. The `end1` is also the stripe size of this component, and is limited by the `lod.*.dom_stripe_size` of the MDT the file is created on. No other options are required for this component. The rest of the components use the normal syntax for composite files creation.

Note

If the next component doesn't specify striping, such as:

```
lfs setstripe -E 1M -L mdt -E EOF <filename>
```

Then that component get its settings from the default filesystem striping.

20.2.1.2. Example

The command below creates a file with a DoM layout. The first component has an mdt layout and is placed on the MDT, covering [0, 1M). The second component covers [1M, EOF) and is striped over all available OSTs.

```
client$ lfs setstripe -E 1M -L mdt -E -1 -S 4M -c -1 \
/mnt/lustre/domfile
```

The resulting layout is illustrated by Figure 20.1, “Resulting file layout”.

Figure 20.1. Resulting file layout

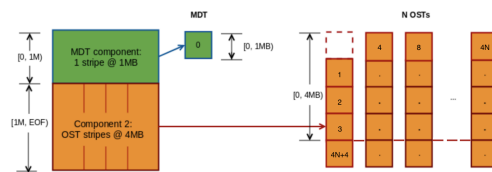

The resulting can also be checked with `lfs getstripe` as shown below:

```
client$ lfs getstripe /mnt/lustre/domfile
/mnt/lustre/domfile
lcm_layout_gen: 2
lcm_mirror_count: 1
lcm_entry_count: 2
lcme_id: 1
lcme_flags: init
lcme_extent.e_start: 0
lcme_extent.e_end: 1048576
lmm_stripe_count: 0
lmm_stripe_size: 1048576
lmm_pattern: mdt
lmm_layout_gen: 0
lmm_stripe_offset: 0
lmm_objects:

lcme_id: 2
lcme_flags: 0
lcme_extent.e_start: 1048576
lcme_extent.e_end: EOF
lmm_stripe_count: -1
lmm_stripe_size: 4194304
lmm_pattern: raid0
lmm_layout_gen: 65535
lmm_stripe_offset: -1
```

The output above shows that the first component has size 1MB and pattern is 'mdt'. The second component is not instantiated yet, which is seen by `lcme_flags: 0`.

If more than 1MB of data is written to the file, then `lfs getstripe` output is changed accordingly:

```

client$ lfs getstripe /mnt/lustre/domfile
/mnt/lustre/domfile
lcm_layout_gen: 3
lcm_mirror_count: 1
lcm_entry_count: 2
  lcme_id: 1
  lcme_flags: init
  lcme_extent.e_start: 0
  lcme_extent.e_end: 1048576
  lmm_stripe_count: 0
  lmm_stripe_size: 1048576
  lmm_pattern: mdt
  lmm_layout_gen: 0
  lmm_stripe_offset: 2
  lmm_objects:

  lcme_id: 2
  lcme_flags: init
  lcme_extent.e_start: 1048576
  lcme_extent.e_end: EOF
  lmm_stripe_count: 2
  lmm_stripe_size: 4194304
  lmm_pattern: raid0
  lmm_layout_gen: 0
  lmm_stripe_offset: 0
  lmm_objects:
- 0: { l_ost_idx: 0, l_fid: [0x100000000:0x2:0x0] }
- 1: { l_ost_idx: 1, l_fid: [0x100010000:0x2:0x0] }

```

The output above shows that the second component now has objects on OSTs with a 4MB stripe.

20.2.2. Setting a default DoM layout to an existing directory

A DoM layout can be set on an existing directory as well. When set, all the files created after that will inherit this layout by default.

20.2.2.1. Command

```

lfs setstripe --component-end|-E end1 --layout|-L mdt \
[--component-end|-E end2 [STRIPE_OPTIONS] ...] <dirname>

```

20.2.2.2. Example

```

client$ mkdir /mnt/lustre/domdir
client$ touch /mnt/lustre/domdir/normfile
client$ lfs setstripe -E 1M -L mdt -E -1 /mnt/lustre/domdir/
client$ lfs getstripe -d /mnt/lustre/domdir
  lcm_layout_gen: 0
  lcm_mirror_count: 1
  lcm_entry_count: 2
  lcme_id: N/A

```

```

lcme_flags:          0
lcme_extent.e_start: 0
lcme_extent.e_end:   1048576
  stripe_count: 0    stripe_size: 1048576  \
  pattern: mdt      stripe_offset: -1

lcme_id:             N/A
lcme_flags:          0
lcme_extent.e_start: 1048576
lcme_extent.e_end:   EOF
  stripe_count: 1    stripe_size: 1048576  \
  pattern: raid0    stripe_offset: -1

```

In the output above, it can be seen that the directory has a default layout with a DoM component.

The following example will check layouts of files in that directory:

```

client$ touch /mnt/lustre/domdir/domfile
client$ lfs getstripe /mnt/lustre/domdir/normfile
/mnt/lustre/domdir/normfile
lmm_stripe_count: 2
lmm_stripe_size: 1048576
lmm_pattern: raid0
lmm_layout_gen: 0
lmm_stripe_offset: 1
  obdidx  objid  objid  group
        1      3      0x3      0
        0      3      0x3      0

client$ lfs getstripe /mnt/lustre/domdir/domfile
/mnt/lustre/domdir/domfile
lcm_layout_gen: 2
lcm_mirror_count: 1
lcm_entry_count: 2
  lcme_id:          1
  lcme_flags:       init
  lcme_extent.e_start: 0
  lcme_extent.e_end: 1048576
    lmm_stripe_count: 0
    lmm_stripe_size: 1048576
    lmm_pattern: mdt
    lmm_layout_gen: 0
    lmm_stripe_offset: 2
    lmm_objects:

  lcme_id:          2
  lcme_flags:       0
  lcme_extent.e_start: 1048576
  lcme_extent.e_end: EOF
    lmm_stripe_count: 1
    lmm_stripe_size: 1048576
    lmm_pattern: raid0

```

```
lmm_layout_gen:    65535
lmm_stripe_offset: -1
```

We can see that first file **normfile** in that directory has an ordinary layout, whereas the file **domfile** inherits the directory default layout and is a DoM file.

Note

The directory default layout setting will be inherited by new files even if the server DoM size limit will be set to a lower value.

20.2.3. DoM Stripe Size Restrictions

The maximum size of a DoM component is restricted in several ways to protect the MDT from being eventually filled with large files.

20.2.3.1. LFS limits for DoM component size

`lfs setstripe` allows for setting the component size for MDT layouts up to 1GB (this is a compile-time limit to avoid improper configuration), however, the size must also be aligned by 64KB due to the minimum stripe size in Lustre (see Table 5.2, “File and file system limits” Minimum stripe size). There is also a limit imposed on each file by `lfs setstripe -E end` that may be smaller than the MDT-imposed limit if this is better for a particular usage.

20.2.3.2. MDT Server Limits

The `lod.$fsname-MDTxxxx.dom_stripesize` is used to control the per-MDT maximum size for a DoM component. Larger DoM components specified by the user will be truncated to the MDT-specified limit, and as such may be different on each MDT to balance DoM space usage on each MDT separately, if needed. It is 1MB by default and can be changed with the `lctl` tool. For more information on setting `dom_stripesize` please see Section 20.2.6, “The `dom_stripesize` parameter”.

20.2.4. lfs getstripe for DoM files

The `lfs getstripe` command is used to list the striping/component information for a given file. For DoM files, it can be used to check its layout and size.

20.2.4.1. Command

```
lfs getstripe [--component-id|-I [comp_id]] [--layout|-L] \
  [--stripe-size|-S] <dirname|filename>
```

20.2.4.2. Examples

```
client$ lfs getstripe -I1 /mnt/lustre/domfile
/mnt/lustre/domfile
lcm_layout_gen:    3
lcm_mirror_count:  1
lcm_entry_count:   2
  lcm_e_id:         1
  lcm_e_flags:      init
  lcm_e_extent.e_start: 0
```

```

lcme_extent.e_end: 1048576
lmm_stripe_count: 0
lmm_stripe_size: 1048576
lmm_pattern: mdt
lmm_layout_gen: 0
lmm_stripe_offset: 2
lmm_objects:

```

Short info about the layout and size of DoM component can be obtained with the use of the `-L` option along with `-S` or `-E` options:

```

client$ lfs getstripe -I1 -L -S /mnt/lustre/domfile
lmm_stripe_size: 1048576
lmm_pattern: mdt
client$ lfs getstripe -I1 -L -E /mnt/lustre/domfile
lcme_extent.e_end: 1048576
lmm_pattern: mdt

```

Both commands return layout type and its size. The stripe size is equal to the extent size of component in case of DoM files, so both can be used to get size on the MDT.

20.2.5. lfs find for DoM files

The `lfs find` command can be used to search the directory tree rooted at the given directory or file name for the files that match the given parameters. The command below shows the new parameters for DoM files and their usages are similar to the `lfs getstripe` command.

20.2.5.1. Command

```
lfs find <directory|filename> [--layout|-L] [...]
```

20.2.5.2. Examples

Find all files with DoM layout under directory `/mnt/lustre`:

```

client$ lfs find -L mdt /mnt/lustre
/mnt/lustre/domfile
/mnt/lustre/domdir
/mnt/lustre/domdir/domfile

client$ lfs find -L mdt -type f /mnt/lustre
/mnt/lustre/domfile
/mnt/lustre/domdir/domfile

client$ lfs find -L mdt -type d /mnt/lustre
/mnt/lustre/domdir

```

By using this command you can find all DoM objects, only DoM files, or only directories with default DoM layout.

Find the DoM files/dirs with a particular stripe size:

```

client$ lfs find -L mdt -S -1200K -type f /mnt/lustre
/mnt/lustre/domfile

```

```
/mnt/lustre/domdir/domfile
```

```
client$ lfs find -L mdt -S +200K -type f /mnt/lustre
/mnt/lustre/domfile
/mnt/lustre/domdir/domfile
```

The first command finds all DoM files with stripe size less than 1200KB. The second command above does the same for files with a stripe size greater than 200KB. In both cases, all DoM files are found because their DoM size is 1MB.

20.2.6. The dom_stripesize parameter

The MDT controls the default maximum DoM size on the server via the parameter `dom_stripesize` in the LOD device. The `dom_stripesize` can be set differently for each MDT, if necessary. The default value of the parameter is 1MB and can be changed with `lctl` tool.

20.2.6.1. Get Command

```
lctl get_param lod.*MDT<index>*.dom_stripesize
```

20.2.6.2. Get Examples

The commands below get the maximum allowed DoM size on the server. The final command is an attempt to create a file with a larger size than the parameter setting and correctly fails.

```
mds# lctl get_param lod.*MDT0000*.dom_stripesize
lod.lustre-MDT0000-mdtlov.dom_stripesize=1048576
```

```
mds# lctl get_param -n lod.*MDT0000*.dom_stripesize
1048576
```

```
client$ lfs setstripe -E 2M -L mdt /mnt/lustre/dom2mb
Create composite file /mnt/lustre/dom2mb failed. Invalid argument
error: setstripe: create composite file '/mnt/lustre/dom2mb' failed:
Invalid argument
```

20.2.6.3. Temporary Set Command

To temporarily set the value of the parameter, the `lctl set_param` is used:

```
lctl set_param lod.*MDT<index>*.dom_stripesize=<value>
```

20.2.6.4. Temporary Set Examples

The example below shows a change to the default DoM limit on the server to 64KB and try to create a file with 1MB DoM size after that.

```
mds# lctl set_param -n lod.*MDT0000*.dom_stripesize=64K
mds# lctl get_param -n lod.*MDT0000*.dom_stripesize
65536
```

```
client$ lfs setstripe -E 1M -L mdt /mnt/lustre/dom
Create composite file /mnt/lustre/dom failed. Invalid argument
error: setstripe: create composite file '/mnt/lustre/dom' failed:
Invalid argument
```

20.2.6.5. Persistent Set Command

To persistently set the value of the parameter on a specific MDT, the `lctl set_param -P` command is used:

```
lctl set_param -P lod.fsname-MDTindex.dom_stripesize=value
```

This can also use a wildcard '*' for the *index* to apply to all MDTs.

20.2.6.6. Persistent Set Examples

The new value of the parameter is saved in the MGS parameters log permanently:

```
mgs# lctl set_param -P lod.lustre-MDT0000.dom_stripesize=512K
mds# lctl get_param -n lod.*MDT0000*.dom_stripesize
524288
```

and are applied on the matching MDTs within a few seconds.

20.2.7. Disable DoM

When `lctl set_param` (whether with `-P` or not) sets `dom_stripesize` to 0, DoM component creation will be disabled on the specified server(s), and any *new* layouts with a specified DoM component will have that component removed from the file layout. Existing files and layouts with DoM components on that MDT are not changed.

Note

DoM files can still be created in existing directories with a default DoM layout.

Chapter 21. Lazy Size on MDT (LSoM)

This chapter describes Lazy Size on MDT (LSoM).

21.1. Introduction to Lazy Size on MDT (LSoM)

In the Lustre file system, MDSs store the ctime, mtime, owner, and other file attributes. The OSSs store the size and number of blocks used for each file. To obtain the correct file size, the client must contact each OST that the file is stored across, which means multiple RPCs to get the size and blocks for a file when a file is striped over multiple OSTs. The Lazy Size on MDT (LSoM) feature stores the file size on the MDS and avoids the need to fetch the file size from the OST(s) in cases where the application understands that the size may not be accurate. Lazy means there is no guarantee of the accuracy of the attributes stored on the MDS.

Since many Lustre installations use SSD for MDT storage, the motivation for the LSoM work is to speed up the time it takes to get the size of a file from the Lustre file system by storing that data on the MDTs. We expect this feature to be initially used by Lustre policy engines that scan the backend MDT storage, make decisions based on broad size categories, and do not depend on a totally accurate file size. Examples include Lester, Robinhood, Zester, and various vendor offerings. Future improvements will allow the LSoM data to be accessed by tools such as `lfs find`.

21.2. Enable LSoM

LSoM is always enabled and nothing needs to be done to enable the feature for fetching the LSoM data when scanning the MDT inodes with a policy engine. It is also possible to access the LSoM data on the client via the `lfs getsom` command. Because the LSoM data is currently accessed on the client via the `xattr` interface, the `xattr_cache` will cache the file size and block count on the client as long as the inode is cached. In most cases this is desirable, since it improves access to the LSoM data. However, it also means that the LSoM data may be stale if the file size is changed after the `xattr` is first accessed or if the `xattr` is accessed shortly after the file is first created.

If it is necessary to access up-to-date LSoM data that has gone stale, it is possible to flush the `xattr` cache from the client by cancelling the MDC locks via `lctl set_param ldlm.namespaces.*mdc*.lru_size=clear`. Otherwise, the file attributes will be dropped from the client cache if the file has not been accessed before the LDLM lock timeout. The timeout is stored via `lctl get_param ldlm.namespaces.*mdc*.lru_max_age`.

If repeated access to LSoM attributes for files that are recently created or frequently modified from a specific client, such as an HSM agent node, it is possible to disable `xattr` caching on a client via: `lctl set_param llite.*.xattr_cache=0`. This may cause extra overhead when accessing files, and is not recommended for normal usage.

21.3. User Commands

Lustre provides the `lfs getsom` command to list file attributes that are stored on the MDT.

The `llsom_sync` command allows the user to sync the file attributes on the MDT with the valid/up-to-date data on the OSTs. `llsom_sync` is called on the client with the Lustre file system mount point. `llsom_sync` uses Lustre MDS changelogs and, thus, a changelog user must be registered to use this utility.

21.3.1. lfs getsom for LSoM data

The `lfs getsom` command lists file attributes that are stored on the MDT. `lfs getsom` is called with the full path and file name for a file on the Lustre file system. If no flags are used, then all file attributes stored on the MDS will be shown.

21.3.1.1. lfs getsom Command

```
lfs getsom [-s] [-b] [-f] <filename>
```

The various `lfs getsom` options are listed and described below.

Option	Description
-s	Only show the size value of the LSoM data for a given file. This is an optional flag
-b	Only show the blocks value of the LSoM data for a given file. This is an optional flag
-f	Only show the flag value of the LSoM data for a given file. This is an optional flag. Valid flags are: SOM_FL_UNKNOWN = 0x0000 - Unknown or no SoM data, must get size from OSTs. SOM_FL_STRICT = 0x0001 - Known strictly correct, FLR file (SoM guaranteed) SOM_FL_STALE = 0x0002 - Known stale -was right at some point in the past, but it is known (or likely) to be incorrect now (e.g. opened for write) SOM_FL_LAZY= 0x0004 - Approximate, may never have been strictly correct, need to sync SOM data to achieve eventual consistency.

21.3.2. Syncing LSoM data

The `llsom_sync` command allows the user to sync the file attributes on the MDT with the valid/up-to-date data on the OSTs. `llsom_sync` is called on the client with the client mount point for the Lustre file system. `llsom_sync` uses Lustre MDS changelogs and, thus, a changelog user must be registered to use this utility.

21.3.2.1. llsom_sync Command

```
llsom_sync --mdt|-m <mdt> --user|-u <user_id>
```

```
[--daemonize|-d] [--verbose|-v] [--interval|-i] [--min-age|-a]
[--max-cache|-c] [--sync|-s] <lustre_mount_point>
```

The various `llsom_sync` options are listed and described below.

Option	Description
<code>--mdt -m <mdt></code>	The metadata device which need to be synced the LSoM xattr of files. A changelog user must be registered for this device. Required flag.
<code>--user -u <user_id></code>	The changelog user id for the MDT device. Required flag.
<code>--daemonize -d</code>	Optional flag to “daemonize” the program. In daemon mode, the utility will scan, process the changelog records and sync the LSoM xattr for files periodically.
<code>--verbose -v</code>	Optional flag to produce verbose output.
<code>--interval -i</code>	Optional flag for the time interval to scan the Lustre changelog and process the log record in daemon mode.
<code>--min-age -a</code>	Optional flag for the time that <code>llsom_sync</code> tool will not try to sync the LSoM data for any files closed less than this many seconds old. The default min-age value is 600s(10 minutes).
<code>--max-cache -c</code>	Optional flag for the total memory used for the FID cache which can be with a suffix [KkGgMm].The default max-cache value is 256MB. For the parameter value < 100, it is taken as the percentage of total memory size used for the FID cache instead of the cache size.
<code>--sync -s</code>	Optional flag to sync file data to make the dirty data out of cache to ensure the blocks count is correct when update the file LSoM xattr. This option could hurt server performance significantly if thousands of fsync requests are sent.

Chapter 22. File Level Redundancy (FLR)

This chapter describes File Level Redundancy (FLR).

22.1. Introduction

The Lustre file system was initially designed and implemented for HPC use. It has been working well on high-end storage that has internal redundancy and fault-tolerance. However, despite the expense and complexity of these storage systems, storage failures still occur, and before release 2.11, Lustre could not be more reliable than the individual storage and servers' components on which it was based. The Lustre file system had no mechanism to mitigate storage hardware failures and files would become inaccessible if a server was inaccessible or otherwise out of service.

With the File Level Redundancy (FLR) feature introduced in Lustre Release 2.11, any Lustre file can store the same data on multiple OSTs in order for the system to be robust in the event of storage failures or other outages. With the choice of multiple mirrors, the best suited mirror can be chosen to satisfy an individual request, which has a direct impact on IO availability. Furthermore, for files that are concurrently read by many clients (e.g. input decks, shared libraries, or executables) the aggregate parallel read performance of a single file can be improved by creating multiple mirrors of the file data.

The first phase of the FLR feature has been implemented with delayed write (Figure 22.1, "FLR Delayed Write"). While writing to a mirrored file, only one primary or preferred mirror will be updated directly during the write, while other mirrors will be simply marked as stale. The file can subsequently return to a mirrored state again by synchronizing among mirrors with command line tools (run by the user or administrator directly or via automated monitoring tools).

Figure 22.1. FLR Delayed Write

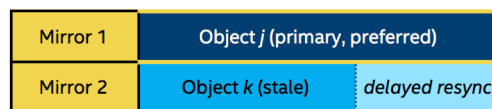

22.2. Operations

Lustre provides `lfs mirror` command line tools for users to operate on mirrored files or directories.

22.2.1. Creating a Mirrored File or Directory

Command:

```
lfs mirror create <--mirror-count|-N[mirror_count]
```

```
[setstripe_options| [--flags<=flags>]]> ... <filename|directory>
```

The above command will create a mirrored file or directory specified by *filename* or *directory*, respectively.

Option	Description
--mirror-count -N[mirror_count]	<p>Indicates the number of mirrors to be created with the following setstripe options. It can be repeated multiple times to separate mirrors that have different layouts.</p> <p>The <i>mirror_count</i> argument is optional and defaults to 1 if it is not specified; if specified, it must follow the option without a space.</p>
setstripe_options	<p>Specifies a specific layout for the mirror. It can be a plain layout with a specific striping pattern or a composite layout, such as Section 19.5, “Progressive File Layout(PFL)”. The options are the same as those for the <code>lfs setstripe</code> command.</p> <p>If <i>setstripe_options</i> are not specified, then the stripe options inherited from the previous component will be used. If there is no previous component, then the <i>stripe_count</i> and <i>stripe_size</i> options inherited from the filesystem-wide default values will be used, and the OST <i>pool_name</i> inherited from the parent directory will be used.</p>
--flags<=flags>	<p>Sets flags to the mirror to be created.</p> <p>Only the <code>prefer</code> flag is supported at this time. This flag will be set to all components that belong to the corresponding mirror. The <code>prefer</code> flag gives a hint to Lustre for which mirrors should be used to serve I/O. When a mirrored file is being read, the component(s) with the <code>prefer</code> flag is likely to be picked to serve the read; and when a mirrored file is prepared to be written, the MDT will tend to choose the component with the <code>prefer</code> flag set and mark the other components with overlapping extents as stale. This flag just provides a hint to Lustre, which means Lustre may still choose mirrors without this flag set, for instance, if all preferred mirrors are unavailable when the I/O occurs. This flag can be set on multiple components.</p> <p>Note: This flag will be set to all components that belong to the corresponding mirror. The</p>

Option	Description
	--comp-flags option also exists, which can be set to individual components at mirror creation time.

Note: For redundancy and fault-tolerance, users need to make sure that different mirrors must be on different OSTs, even OSSs and racks. An understanding of cluster topology is necessary to achieve this architecture. In the initial implementation the use of the existing OST pools mechanism will allow separating OSTs by any arbitrary criteria: i.e. fault domain. In practice, users can take advantage of OST pools by grouping OSTs by topological information. Therefore, when creating a mirrored file, users can indicate which OST pools can be used by mirrors.

Examples:

The following command creates a mirrored file with 2 plain layout mirrors:

```
client# lfs mirror create -N -S 4M -c 2 -p flash \
                        -N -c -1 -p archive /mnt/testfs/file1
```

The following command displays the layout information of the mirrored file /mnt/testfs/file1:

```
client# lfs getstripe /mnt/testfs/file1
/mnt/testfs/file1
  lcm_layout_gen:      2
  lcm_mirror_count:   2
  lcm_entry_count:    2
  lcme_id:            65537
  lcme_mirror_id:     1
  lcme_flags:         init
  lcme_extent.e_start: 0
  lcme_extent.e_end:  EOF
  lmm_stripe_count:   2
  lmm_stripe_size:    4194304
  lmm_pattern:        raid0
  lmm_layout_gen:     0
  lmm_stripe_offset:  1
  lmm_pool:           flash
  lmm_objects:
- 0: { l_ost_idx: 1, l_fid: [0x100010000:0x2:0x0] }
- 1: { l_ost_idx: 0, l_fid: [0x100000000:0x2:0x0] }

  lcme_id:            131074
  lcme_mirror_id:     2
  lcme_flags:         init
  lcme_extent.e_start: 0
  lcme_extent.e_end:  EOF
  lmm_stripe_count:   6
  lmm_stripe_size:    4194304
  lmm_pattern:        raid0
  lmm_layout_gen:     0
  lmm_stripe_offset:  3
  lmm_pool:           archive
```

```
lmm_objects:
- 0: { l_ost_idx: 3, l_fid: [0x100030000:0x2:0x0] }
- 1: { l_ost_idx: 4, l_fid: [0x100040000:0x2:0x0] }
- 2: { l_ost_idx: 5, l_fid: [0x100050000:0x2:0x0] }
- 3: { l_ost_idx: 6, l_fid: [0x100060000:0x2:0x0] }
- 4: { l_ost_idx: 7, l_fid: [0x100070000:0x2:0x0] }
- 5: { l_ost_idx: 2, l_fid: [0x100020000:0x2:0x0] }
```

The first mirror has 4MB stripe size and two stripes across OSTs in the “flash” OST pool. The second mirror has 4MB stripe size inherited from the first mirror, and stripes across all of the available OSTs in the “archive” OST pool.

As mentioned above, it is recommended to use the `--pool|-p` option (one of the `lfs setstripe` options) with OST pools configured with independent fault domains to ensure different mirrors will be placed on different OSTs, servers, and/or racks, thereby improving availability and performance. If the `setstripe` options are not specified, it is possible to create mirrors with objects on the same OST(s), which would remove most of the benefit of using replication.

In the layout information printed by `lfs getstripe`, `lcme_mirror_id` shows mirror ID, which is the unique numerical identifier for a mirror. And `lcme_flags` shows mirrored component flags. Valid flag names are:

- `init` - indicates mirrored component has been initialized (has allocated OST objects).
- `stale` - indicates mirrored component does not have up-to-date data. Stale components will not be used for read or write operations, and need to be resynchronized by running `lfs mirror resync` command before they can be accessed again.
- `prefer` - indicates mirrored component is preferred for read or write. For example, the mirror is located on SSD-based OSTs or is closer, fewer hops, on the network to the client. This flag can be set by users at mirror creation time.

The following command creates a mirrored file with 3 PFL mirrors:

```
client# lfs mirror create -N -E 4M -p flash --flags=prefer -E eof -c 2 \
-N -E 16M -S 8M -c 4 -p archive --comp-flags=prefer -E eof -c -1 \
-N -E 32M -c 1 -p none -E eof -c -1 /mnt/testfs/file2
```

The following command displays the layout information of the mirrored file `/mnt/testfs/file2`:

```
client# lfs getstripe /mnt/testfs/file2
/mnt/testfs/file2
lcm_layout_gen:      6
lcm_mirror_count:    3
lcm_entry_count:     6
  lcme_id:            65537
  lcme_mirror_id:     1
  lcme_flags:         init,prefer
  lcme_extent.e_start: 0
  lcme_extent.e_end:  4194304
    lmm_stripe_count:  1
    lmm_stripe_size:  1048576
    lmm_pattern:      raid0
```

```
lmm_layout_gen:    0
lmm_stripe_offset: 1
lmm_pool:          flash
lmm_objects:
- 0: { l_ost_idx: 1, l_fid: [0x100010000:0x3:0x0] }

lcme_id:           65538
lcme_mirror_id:    1
lcme_flags:        prefer
lcme_extent.e_start: 4194304
lcme_extent.e_end: EOF
  lmm_stripe_count: 2
  lmm_stripe_size: 1048576
  lmm_pattern:      raid0
  lmm_layout_gen:  0
  lmm_stripe_offset: -1
  lmm_pool:         flash

lcme_id:           131075
lcme_mirror_id:    2
lcme_flags:        init,prefer
lcme_extent.e_start: 0
lcme_extent.e_end: 16777216
  lmm_stripe_count: 4
  lmm_stripe_size: 8388608
  lmm_pattern:      raid0
  lmm_layout_gen:  0
  lmm_stripe_offset: 4
  lmm_pool:         archive
lmm_objects:
- 0: { l_ost_idx: 4, l_fid: [0x100040000:0x3:0x0] }
- 1: { l_ost_idx: 5, l_fid: [0x100050000:0x3:0x0] }
- 2: { l_ost_idx: 6, l_fid: [0x100060000:0x3:0x0] }
- 3: { l_ost_idx: 7, l_fid: [0x100070000:0x3:0x0] }

lcme_id:           131076
lcme_mirror_id:    2
lcme_flags:        0
lcme_extent.e_start: 16777216
lcme_extent.e_end: EOF
  lmm_stripe_count: 6
  lmm_stripe_size: 8388608
  lmm_pattern:      raid0
  lmm_layout_gen:  0
  lmm_stripe_offset: -1
  lmm_pool:         archive

lcme_id:           196613
lcme_mirror_id:    3
lcme_flags:        init
lcme_extent.e_start: 0
lcme_extent.e_end: 33554432
  lmm_stripe_count: 1
  lmm_stripe_size: 8388608
```

```

lmm_pattern:      raid0
lmm_layout_gen:   0
lmm_stripe_offset: 0
lmm_objects:
- 0: { l_ost_idx: 0, l_fid: [0x100000000:0x3:0x0] }

lcme_id:          196614
lcme_mirror_id:   3
lcme_flags:       0
lcme_extent.e_start: 33554432
lcme_extent.e_end: EOF
  lmm_stripe_count: -1
  lmm_stripe_size:  8388608
  lmm_pattern:      raid0
  lmm_layout_gen:   0
  lmm_stripe_offset: -1

```

For the first mirror, the first component inherits the stripe count and stripe size from filesystem-wide default values. The second component inherits the stripe size and OST pool from the first component, and has two stripes. Both of the components are allocated from the “flash” OST pool. Also, the flag `prefer` is applied to all the components of the first mirror, which tells the client to read data from those components whenever they are available.

For the second mirror, the first component has an 8MB stripe size and 4 stripes across OSTs in the “archive” OST pool. The second component inherits the stripe size and OST pool from the first component, and stripes across all of the available OSTs in the “archive” OST pool. The flag `prefer` is only applied to the first component.

For the third mirror, the first component inherits the stripe size of 8MB from the last component of the second mirror, and has one single stripe. The OST pool name is cleared and inherited from the parent directory (if it was set with OST pool name). The second component inherits stripe size from the first component, and stripes across all of the available OSTs.

22.2.2. Extending a Mirrored File

Command:

```
lfs mirror extend [--no-verify] <--mirror-count|-N[mirror_count]
[setstripe_options|-f <victim_file>]> ... <filename>
```

The above command will append mirror(s) indicated by `setstripe options` or just take the layout from existing file `victim_file` into the file `filename`. The `filename` must be an existing file, however, it can be a mirrored or regular non-mirrored file. If it is a non-mirrored file, the command will convert it to a mirrored file.

Option	Description
<code>--mirror-count -N[mirror_count]</code>	Indicates the number of mirrors to be added with the following <code>setstripe options</code> . It can be repeated multiple times to separate mirrors that have different layouts. The <code>mirror_count</code> argument is optional and defaults to 1 if it is not specified; if

Option	Description
	specified, it must follow the option without a space.
setstripe_options	<p>Specifies a specific layout for the mirror. It can be a plain layout with specific striping pattern or a composite layout, such as Section 19.5, “Progressive File Layout(PFL)”. The options are the same as those for the <code>lfs setstripe</code> command.</p> <p>If <code>setstripe_options</code> are not specified, then the stripe options inherited from the previous component will be used. If there is no previous component, then the <code>stripe_count</code> and <code>stripe_size</code> options inherited from filesystem-wide default values will be used, and the OST <code>pool_name</code> inherited from parent directory will be used.</p>
-f <victim_file>	<p>If <code>victim_file</code> exists, the command will split the layout from that file and use it as a mirror added to the mirrored file. After the command is finished, the <code>victim_file</code> will be removed.</p> <p>Note: The <code>setstripe_options</code> cannot be specified with <code>-f <victim_file></code> option in one command line.</p>
--no-verify	<p>If <code>victim_file</code> is specified, the command will verify that the file contents from <code>victim_file</code> are the same as <code>filename</code>. Otherwise, the command will return a failure. However, the option <code>--no-verify</code> can be used to override this verification. This option can save significant time on file comparison if the file size is large, but use it only when the file contents are known to be the same.</p>

Note: The `lfs mirror extend` operation won't be applied to the directory.

Examples:

The following commands create a non-mirrored file, convert it to a mirrored file, and extend it with a plain layout mirror:

```
# lfs setstripe -p flash /mnt/testfs/file1
# lfs getstripe /mnt/testfs/file1
/mnt/testfs/file1
lmm_stripe_count: 1
lmm_stripe_size: 1048576
lmm_pattern: raid0
lmm_layout_gen: 0
```

```

lmm_stripe_offset: 0
lmm_pool:          flash
                   obdidx      objid      objid      group
                   0            4          0x4        0

# lfs mirror extend -N -S 8M -c -1 -p archive /mnt/testfs/file1
# lfs getstripe /mnt/testfs/file1
/mnt/testfs/file1
lcm_layout_gen:    2
lcm_mirror_count:  2
lcm_entry_count:   2
lcme_id:           65537
lcme_mirror_id:    1
lcme_flags:        init
lcme_extent.e_start: 0
lcme_extent.e_end: EOF
lmm_stripe_count:  1
lmm_stripe_size:   1048576
lmm_pattern:       raid0
lmm_layout_gen:    0
lmm_stripe_offset: 0
lmm_pool:          flash
lmm_objects:
- 0: { l_ost_idx: 0, l_fid: [0x100000000:0x4:0x0] }

lcme_id:           131073
lcme_mirror_id:    2
lcme_flags:        init
lcme_extent.e_start: 0
lcme_extent.e_end: EOF
lmm_stripe_count:  6
lmm_stripe_size:   8388608
lmm_pattern:       raid0
lmm_layout_gen:    0
lmm_stripe_offset: 3
lmm_pool:          archive
lmm_objects:
- 0: { l_ost_idx: 3, l_fid: [0x100030000:0x3:0x0] }
- 1: { l_ost_idx: 4, l_fid: [0x100040000:0x4:0x0] }
- 2: { l_ost_idx: 5, l_fid: [0x100050000:0x4:0x0] }
- 3: { l_ost_idx: 6, l_fid: [0x100060000:0x4:0x0] }
- 4: { l_ost_idx: 7, l_fid: [0x100070000:0x4:0x0] }
- 5: { l_ost_idx: 2, l_fid: [0x100020000:0x3:0x0] }

```

The following commands split the PFL layout from a *victim_file* and use it as a mirror added to the mirrored file `/mnt/testfs/file1` created in the above example without data verification:

```

# lfs setstripe -E 16M -c 2 -p none \
               -E eof -c -1 /mnt/testfs/victim_file
# lfs getstripe /mnt/testfs/victim_file
/mnt/testfs/victim_file
lcm_layout_gen:    2
lcm_mirror_count:  1

```

```

lcm_entry_count: 2
  lcme_id: 1
  lcme_mirror_id: 0
  lcme_flags: init
  lcme_extent.e_start: 0
  lcme_extent.e_end: 16777216
  lmm_stripe_count: 2
  lmm_stripe_size: 1048576
  lmm_pattern: raid0
  lmm_layout_gen: 0
  lmm_stripe_offset: 5
  lmm_objects:
    - 0: { l_ost_idx: 5, l_fid: [0x100050000:0x5:0x0] }
    - 1: { l_ost_idx: 6, l_fid: [0x100060000:0x5:0x0] }

  lcme_id: 2
  lcme_mirror_id: 0
  lcme_flags: 0
  lcme_extent.e_start: 16777216
  lcme_extent.e_end: EOF
  lmm_stripe_count: -1
  lmm_stripe_size: 1048576
  lmm_pattern: raid0
  lmm_layout_gen: 0
  lmm_stripe_offset: -1

# lfs mirror extend --no-verify -N -f /mnt/testfs/victim_file \
  /mnt/testfs/file1
# lfs getstripe /mnt/testfs/file1
/mnt/testfs/file1
lcm_layout_gen: 3
lcm_mirror_count: 3
lcm_entry_count: 4
  lcme_id: 65537
  lcme_mirror_id: 1
  lcme_flags: init
  lcme_extent.e_start: 0
  lcme_extent.e_end: EOF
  lmm_stripe_count: 1
  lmm_stripe_size: 1048576
  lmm_pattern: raid0
  lmm_layout_gen: 0
  lmm_stripe_offset: 0
  lmm_pool: flash
  lmm_objects:
    - 0: { l_ost_idx: 0, l_fid: [0x100000000:0x4:0x0] }

  lcme_id: 131073
  lcme_mirror_id: 2
  lcme_flags: init
  lcme_extent.e_start: 0
  lcme_extent.e_end: EOF
  lmm_stripe_count: 6
  lmm_stripe_size: 8388608

```

```

lmm_pattern:      raid0
lmm_layout_gen:   0
lmm_stripe_offset: 3
lmm_pool:         archive
lmm_objects:
- 0: { l_ost_idx: 3, l_fid: [0x100030000:0x3:0x0] }
- 1: { l_ost_idx: 4, l_fid: [0x100040000:0x4:0x0] }
- 2: { l_ost_idx: 5, l_fid: [0x100050000:0x4:0x0] }
- 3: { l_ost_idx: 6, l_fid: [0x100060000:0x4:0x0] }
- 4: { l_ost_idx: 7, l_fid: [0x100070000:0x4:0x0] }
- 5: { l_ost_idx: 2, l_fid: [0x100020000:0x3:0x0] }

lcme_id:          196609
lcme_mirror_id:   3
lcme_flags:       init
lcme_extent.e_start: 0
lcme_extent.e_end: 16777216
  lmm_stripe_count: 2
  lmm_stripe_size: 1048576
  lmm_pattern:     raid0
  lmm_layout_gen:  0
  lmm_stripe_offset: 5
  lmm_objects:
- 0: { l_ost_idx: 5, l_fid: [0x100050000:0x5:0x0] }
- 1: { l_ost_idx: 6, l_fid: [0x100060000:0x5:0x0] }

lcme_id:          196610
lcme_mirror_id:   3
lcme_flags:       0
lcme_extent.e_start: 16777216
lcme_extent.e_end: EOF
  lmm_stripe_count: -1
  lmm_stripe_size: 1048576
  lmm_pattern:     raid0
  lmm_layout_gen:  0
  lmm_stripe_offset: -1

```

After extending, the *victim_file* was removed:

```

# ls /mnt/testfs/victim_file
ls: cannot access /mnt/testfs/victim_file: No such file or directory

```

22.2.3. Splitting a Mirrored File

Command:

```

lfs mirror split [--mirror-id <mirror_id>]
[--destroy|-d] [-f <new_file>] <mirrored_file>

```

The above command will split a specified mirror with ID *<mirror_id>* out of an existing mirrored file specified by *mirrored_file*. By default, a new file named *<mirrored_file>.mirror~<mirror_id>* will be created with the layout of the split mirror. If the `--destroy|-d` option is specified, then the split mirror will be destroyed. If the `-f <new_file>` option is specified, then a file named *new_file* will be created with

the layout of the split mirror. If *mirrored_file* has only one mirror existing after split, it will be converted to a regular non-mirrored file. If the original *mirrored_file* is not a mirrored file, then the command will return an error.

Option	Description
--mirror-id <mirror_id>	The unique numerical identifier for a mirror. The mirror ID is unique within a mirrored file and is automatically assigned at file creation or extension time. It can be fetched by the <code>lfs getstripe</code> command.
--destroy -d	Indicates the split mirror will be destroyed.
-f <new_file>	Indicates a file named <i>new_file</i> will be created with the layout of the split mirror.

Examples:

The following commands create a mirrored file with 4 mirrors, then split 3 mirrors separately from the mirrored file.

Creating a mirrored file with 4 mirrors:

```
# lfs mirror create -N2 -E 4M -p flash -E eof -c -1 \
                    -N2 -S 8M -c 2 -p archive /mnt/testfs/file1
# lfs getstripe /mnt/testfs/file1
/mnt/testfs/file1
lcm_layout_gen:      6
lcm_mirror_count:    4
lcm_entry_count:     6
  lcme_id:            65537
  lcme_mirror_id:     1
  lcme_flags:         init
  lcme_extent.e_start: 0
  lcme_extent.e_end:  4194304
    lmm_stripe_count:  1
    lmm_stripe_size:   1048576
    lmm_pattern:       raid0
    lmm_layout_gen:    0
    lmm_stripe_offset: 1
    lmm_pool:          flash
  lmm_objects:
    - 0: { l_ost_idx: 1, l_fid: [0x100010000:0x4:0x0] }

  lcme_id:            65538
  lcme_mirror_id:     1
  lcme_flags:         0
  lcme_extent.e_start: 4194304
  lcme_extent.e_end:  EOF
    lmm_stripe_count:  2
    lmm_stripe_size:   1048576
    lmm_pattern:       raid0
    lmm_layout_gen:    0
    lmm_stripe_offset: -1
    lmm_pool:          flash
```

```
lcme_id:          131075
lcme_mirror_id:   2
lcme_flags:       init
lcme_extent.e_start: 0
lcme_extent.e_end: 4194304
  lmm_stripe_count: 1
  lmm_stripe_size: 1048576
  lmm_pattern:     raid0
  lmm_layout_gen: 0
  lmm_stripe_offset: 0
  lmm_pool:        flash
  lmm_objects:
- 0: { l_ost_idx: 0, l_fid: [0x100000000:0x5:0x0] }

lcme_id:          131076
lcme_mirror_id:   2
lcme_flags:       0
lcme_extent.e_start: 4194304
lcme_extent.e_end: EOF
  lmm_stripe_count: 2
  lmm_stripe_size: 1048576
  lmm_pattern:     raid0
  lmm_layout_gen: 0
  lmm_stripe_offset: -1
  lmm_pool:        flash

lcme_id:          196613
lcme_mirror_id:   3
lcme_flags:       init
lcme_extent.e_start: 0
lcme_extent.e_end: EOF
  lmm_stripe_count: 2
  lmm_stripe_size: 8388608
  lmm_pattern:     raid0
  lmm_layout_gen: 0
  lmm_stripe_offset: 4
  lmm_pool:        archive
  lmm_objects:
- 0: { l_ost_idx: 4, l_fid: [0x100040000:0x5:0x0] }
- 1: { l_ost_idx: 5, l_fid: [0x100050000:0x6:0x0] }

lcme_id:          262150
lcme_mirror_id:   4
lcme_flags:       init
lcme_extent.e_start: 0
lcme_extent.e_end: EOF
  lmm_stripe_count: 2
  lmm_stripe_size: 8388608
  lmm_pattern:     raid0
  lmm_layout_gen: 0
  lmm_stripe_offset: 7
  lmm_pool:        archive
  lmm_objects:
```

```
- 0: { l_ost_idx: 7, l_fid: [0x100070000:0x5:0x0] }
- 1: { l_ost_idx: 2, l_fid: [0x100020000:0x4:0x0] }
```

Splitting the mirror with ID 1 from /mnt/testfs/file1 and creating /mnt/testfs/file1.mirror~1 with the layout of the split mirror:

```
# lfs mirror split --mirror-id 1 /mnt/testfs/file1
# lfs getstripe /mnt/testfs/file1.mirror~1
/mnt/testfs/file1.mirror~1
lcm_layout_gen:      1
lcm_mirror_count:    1
lcm_entry_count:     2
lcme_id:              65537
lcme_mirror_id:      1
lcme_flags:           init
lcme_extent.e_start: 0
lcme_extent.e_end:   4194304
lmm_stripe_count:    1
lmm_stripe_size:     1048576
lmm_pattern:         raid0
lmm_layout_gen:      0
lmm_stripe_offset:   1
lmm_pool:            flash
lmm_objects:
- 0: { l_ost_idx: 1, l_fid: [0x100010000:0x4:0x0] }

lcme_id:              65538
lcme_mirror_id:      1
lcme_flags:           0
lcme_extent.e_start: 4194304
lcme_extent.e_end:   EOF
lmm_stripe_count:    2
lmm_stripe_size:     1048576
lmm_pattern:         raid0
lmm_layout_gen:      0
lmm_stripe_offset:   -1
lmm_pool:            flash
```

Splitting the mirror with ID 2 from /mnt/testfs/file1 and destroying it:

```
# lfs mirror split --mirror-id 2 -d /mnt/testfs/file1
# lfs getstripe /mnt/testfs/file1
/mnt/testfs/file1
lcm_layout_gen:      8
lcm_mirror_count:    2
lcm_entry_count:     2
lcme_id:              196613
lcme_mirror_id:      3
lcme_flags:           init
lcme_extent.e_start: 0
lcme_extent.e_end:   EOF
lmm_stripe_count:    2
lmm_stripe_size:     8388608
lmm_pattern:         raid0
lmm_layout_gen:      0
```

```

lmm_stripe_offset: 4
lmm_pool:          archive
lmm_objects:
- 0: { l_ost_idx: 4, l_fid: [0x100040000:0x5:0x0] }
- 1: { l_ost_idx: 5, l_fid: [0x100050000:0x6:0x0] }

lcme_id:          262150
lcme_mirror_id:   4
lcme_flags:       init
lcme_extent.e_start: 0
lcme_extent.e_end: EOF
  lmm_stripe_count: 2
  lmm_stripe_size: 8388608
  lmm_pattern:     raid0
  lmm_layout_gen: 0
  lmm_stripe_offset: 7
lmm_pool:          archive
lmm_objects:
- 0: { l_ost_idx: 7, l_fid: [0x100070000:0x5:0x0] }
- 1: { l_ost_idx: 2, l_fid: [0x100020000:0x4:0x0] }

```

Splitting the mirror with ID 3 from /mnt/testfs/file1 and creating /mnt/testfs/file2 with the layout of the split mirror:

```

# lfs mirror split --mirror-id 3 -f /mnt/testfs/file2 \
                  /mnt/testfs/file1
# lfs getstripe /mnt/testfs/file2
/mnt/testfs/file2
lcm_layout_gen: 1
lcm_mirror_count: 1
lcm_entry_count: 1
lcme_id:          196613
lcme_mirror_id:   3
lcme_flags:       init
lcme_extent.e_start: 0
lcme_extent.e_end: EOF
  lmm_stripe_count: 2
  lmm_stripe_size: 8388608
  lmm_pattern:     raid0
  lmm_layout_gen: 0
  lmm_stripe_offset: 4
lmm_pool:          archive
lmm_objects:
- 0: { l_ost_idx: 4, l_fid: [0x100040000:0x5:0x0] }
- 1: { l_ost_idx: 5, l_fid: [0x100050000:0x6:0x0] }

# lfs getstripe /mnt/testfs/file1
/mnt/testfs/file1
lcm_layout_gen: 9
lcm_mirror_count: 1
lcm_entry_count: 1
lcme_id:          262150
lcme_mirror_id:   4
lcme_flags:       init

```



```

lcme_extent.e_start: 0
lcme_extent.e_end:   EOF
lmm_stripe_count:   2
lmm_stripe_size:    8388608
lmm_pattern:        raid0
lmm_layout_gen:     0
lmm_stripe_offset:  7
lmm_pool:            archive
lmm_objects:
- 0: { l_ost_idx: 7, l_fid: [0x100070000:0x5:0x0] }
- 1: { l_ost_idx: 2, l_fid: [0x100020000:0x4:0x0] }

```

The above layout information showed that mirrors with ID 1, 2, and 3 were all split from the mirrored file `/mnt/testfs/file1`.

22.2.4. Resynchronizing out-of-sync Mirrored File(s)

Command:

```
lfs mirror resync [--only <mirror_id[,...]>]
<mirrored_file> [<mirrored_file2>...]
```

The above command will resynchronize out-of-sync mirrored file(s) specified by *mirrored_file*. It supports specifying multiple mirrored files in one command line.

If there is no stale mirror for the specified mirrored file(s), then the command does nothing. Otherwise, it will copy data from synced mirror to the stale mirror(s), and mark all successfully copied mirror(s) as SYNC. If the `--only <mirror_id[,...]>` option is specified, then the command will only resynchronize the mirror(s) specified by the *mirror_id(s)*. This option cannot be used when multiple mirrored files are specified.

Option	Description
<code>--only <mirror_id[,...]></code>	Indicates which mirror(s) specified by <i>mirror_id(s)</i> needs to be resynchronized. The <i>mirror_id</i> is the unique numerical identifier for a mirror. Multiple <i>mirror_ids</i> are separated by comma. This option cannot be used when multiple mirrored files are specified.

Note: With delayed write implemented in FLR phase 1, after writing to a mirrored file, users need to run `lfs mirror resync` command to get all mirrors synchronized.

Examples:

The following commands create a mirrored file with 3 mirrors, then write some data into the file and resynchronizes stale mirrors.

Creating a mirrored file with 3 mirrors:

```
# lfs mirror create -N -E 4M -p flash -E eof \
                  -N2 -p archive /mnt/testfs/file1
```

```

# lfs getstripe /mnt/testfs/file1
/mnt/testfs/file1
lcm_layout_gen:      4
lcm_mirror_count:    3
lcm_entry_count:     4
  lcme_id:            65537
  lcme_mirror_id:     1
  lcme_flags:         init
  lcme_extent.e_start: 0
  lcme_extent.e_end:  4194304
    lmm_stripe_count:  1
    lmm_stripe_size:   1048576
    lmm_pattern:       raid0
    lmm_layout_gen:    0
    lmm_stripe_offset: 1
    lmm_pool:          flash
    lmm_objects:
      - 0: { l_ost_idx: 1, l_fid: [0x100010000:0x5:0x0] }

  lcme_id:            65538
  lcme_mirror_id:     1
  lcme_flags:         0
  lcme_extent.e_start: 4194304
  lcme_extent.e_end:  EOF
    lmm_stripe_count:  1
    lmm_stripe_size:   1048576
    lmm_pattern:       raid0
    lmm_layout_gen:    0
    lmm_stripe_offset: -1
    lmm_pool:          flash

  lcme_id:            131075
  lcme_mirror_id:     2
  lcme_flags:         init
  lcme_extent.e_start: 0
  lcme_extent.e_end:  EOF
    lmm_stripe_count:  1
    lmm_stripe_size:   1048576
    lmm_pattern:       raid0
    lmm_layout_gen:    0
    lmm_stripe_offset: 3
    lmm_pool:          archive
    lmm_objects:
      - 0: { l_ost_idx: 3, l_fid: [0x100030000:0x4:0x0] }

  lcme_id:            196612
  lcme_mirror_id:     3
  lcme_flags:         init
  lcme_extent.e_start: 0
  lcme_extent.e_end:  EOF
    lmm_stripe_count:  1
    lmm_stripe_size:   1048576
    lmm_pattern:       raid0
    lmm_layout_gen:    0

```

```

lmm_stripe_offset: 4
lmm_pool:          archive
lmm_objects:
- 0: { l_ost_idx: 4, l_fid: [0x100040000:0x6:0x0] }

```

Writing some data into the mirrored file /mnt/testfs/file1:

```

# yes | dd of=/mnt/testfs/file1 bs=1M count=2
2+0 records in
2+0 records out
2097152 bytes (2.1 MB) copied, 0.0320613 s, 65.4 MB/s

```

```

# lfs getstripe /mnt/testfs/file1
/mnt/testfs/file1
lcm_layout_gen:      5
lcm_mirror_count:    3
lcm_entry_count:     4
  lcme_id:            65537
  lcme_mirror_id:     1
  lcme_flags:         init
  lcme_extent.e_start: 0
  lcme_extent.e_end: 4194304
  .....
  lcme_id:            65538
  lcme_mirror_id:     1
  lcme_flags:         0
  lcme_extent.e_start: 4194304
  lcme_extent.e_end:  EOF
  .....
  lcme_id:            131075
  lcme_mirror_id:     2
  lcme_flags:         init,stale
  lcme_extent.e_start: 0
  lcme_extent.e_end:  EOF
  .....
  lcme_id:            196612
  lcme_mirror_id:     3
  lcme_flags:         init,stale
  lcme_extent.e_start: 0
  lcme_extent.e_end:  EOF
  .....

```

The above layout information showed that data were written into the first component of mirror with ID 1, and mirrors with ID 2 and 3 were marked with “stale” flag.

Resynchronizing the stale mirror with ID 2 for the mirrored file /mnt/testfs/file1:

```

# lfs mirror resync --only 2 /mnt/testfs/file1
# lfs getstripe /mnt/testfs/file1
/mnt/testfs/file1
lcm_layout_gen:      7
lcm_mirror_count:    3

```

```

lcm_entry_count: 4
  lcme_id: 65537
  lcme_mirror_id: 1
  lcme_flags: init
  lcme_extent.e_start: 0
  lcme_extent.e_end: 4194304
  .....

  lcme_id: 65538
  lcme_mirror_id: 1
  lcme_flags: 0
  lcme_extent.e_start: 4194304
  lcme_extent.e_end: EOF
  .....

  lcme_id: 131075
  lcme_mirror_id: 2
  lcme_flags: init
  lcme_extent.e_start: 0
  lcme_extent.e_end: EOF
  .....

  lcme_id: 196612
  lcme_mirror_id: 3
  lcme_flags: init, stale
  lcme_extent.e_start: 0
  lcme_extent.e_end: EOF
  .....

```

The above layout information showed that after resynchronizing, the “stale” flag was removed from mirror with ID 2.

Resynchronizing all of the stale mirrors for the mirrored file /mnt/testfs/file1:

```

# lfs mirror resync /mnt/testfs/file1
# lfs getstripe /mnt/testfs/file1
/mnt/testfs/file1
  lcm_layout_gen: 9
  lcm_mirror_count: 3
  lcm_entry_count: 4
    lcme_id: 65537
    lcme_mirror_id: 1
    lcme_flags: init
    lcme_extent.e_start: 0
    lcme_extent.e_end: 4194304
    .....

    lcme_id: 65538
    lcme_mirror_id: 1
    lcme_flags: 0
    lcme_extent.e_start: 4194304
    lcme_extent.e_end: EOF
    .....

```

```

lcme_id:                131075
lcme_mirror_id:         2
lcme_flags:             init
lcme_extent.e_start:   0
lcme_extent.e_end:     EOF
.....

lcme_id:                196612
lcme_mirror_id:         3
lcme_flags:             init
lcme_extent.e_start:   0
lcme_extent.e_end:     EOF
.....

```

The above layout information showed that after resynchronizing, none of the mirrors were marked as stale.

22.2.5. Verifying Mirrored File(s)

Command:

```

lfs mirror verify [--only <mirror_id,mirror_id2[,...]>]
[--verbose|-v] <mirrored_file> [<mirrored_file2> ...]

```

The above command will verify that each SYNC mirror (contains up-to-date data) of a mirrored file, specified by *mirrored_file*, has exactly the same data. It supports specifying multiple mirrored files in one command line.

This is a scrub tool that should be run on regular basis to make sure that mirrored files are not corrupted. The command won't repair the file if it turns out to be corrupted. Usually, an administrator should check the file content from each mirror and decide which one is correct and then invoke `lfs mirror resync` to repair it manually.

Option	Description
--only <mirror_id,mirror_id2[,...]>	Indicates which mirrors specified by <i>mirror_ids</i> need to be verified. The <i>mirror_id</i> is the unique numerical identifier for a mirror. Multiple <i>mirror_ids</i> are separated by comma. Note: At least two <i>mirror_ids</i> are required. This option cannot be used when multiple mirrored files are specified.
--verbose -v	Indicates the command will print where the differences are if the data do not match. Otherwise, the command will just return an error in that case. This option can be repeated for multiple times to print more information.

Note:

Mirror components that have “stale” or “offline” flags will be skipped and not verified.

Examples:

The following command verifies that each mirror of a mirrored file contains exactly the same data:

```
# lfs mirror verify /mnt/testfs/file1
```

The following command has the `-v` option specified to print where the differences are if the data does not match:

```
# lfs mirror verify -vvv /mnt/testfs/file2
Chunks to be verified in /mnt/testfs/file2:
[0, 0x200000) [1, 2, 3, 4] 4
[0x200000, 0x400000) [1, 2, 3, 4] 4
[0x400000, 0x600000) [1, 2, 3, 4] 4
[0x600000, 0x800000) [1, 2, 3, 4] 4
[0x800000, 0xa00000) [1, 2, 3, 4] 4
[0xa00000, 0x1000000) [1, 2, 3, 4] 4
[0x1000000, 0xffffffffffffffff) [1, 2, 3, 4] 4

Verifying chunk [0, 0x200000) on mirror: 1 2 3 4
CRC-32 checksum value for chunk [0, 0x200000):
Mirror 1: 0x207b02f1
Mirror 2: 0x207b02f1
Mirror 3: 0x207b02f1
Mirror 4: 0x207b02f1

Verifying chunk [0, 0x200000) on mirror: 1 2 3 4 PASS

Verifying chunk [0x200000, 0x400000) on mirror: 1 2 3 4
CRC-32 checksum value for chunk [0x200000, 0x400000):
Mirror 1: 0x207b02f1
Mirror 2: 0x207b02f1
Mirror 3: 0x207b02f1
Mirror 4: 0x207b02f1

Verifying chunk [0x200000, 0x400000) on mirror: 1 2 3 4 PASS

Verifying chunk [0x400000, 0x600000) on mirror: 1 2 3 4
CRC-32 checksum value for chunk [0x400000, 0x600000):
Mirror 1: 0x42571b66
Mirror 2: 0x42571b66
Mirror 3: 0x42571b66
Mirror 4: 0xabdaf92

lfs mirror verify: chunk [0x400000, 0x600000) has different
checksum value on mirror 1 and mirror 4.
Verifying chunk [0x600000, 0x800000) on mirror: 1 2 3 4
CRC-32 checksum value for chunk [0x600000, 0x800000):
Mirror 1: 0x1f8ad0d8
Mirror 2: 0x1f8ad0d8
Mirror 3: 0x1f8ad0d8
Mirror 4: 0x18975bf9

lfs mirror verify: chunk [0x600000, 0x800000) has different
```

```

checksum value on mirror 1 and mirror 4.
Verifying chunk [0x800000, 0xa00000) on mirror: 1 2 3 4
CRC-32 checksum value for chunk [0x800000, 0xa00000):
Mirror 1:      0x69c17478
Mirror 2:      0x69c17478
Mirror 3:      0x69c17478
Mirror 4:      0x69c17478

Verifying chunk [0x800000, 0xa00000) on mirror: 1 2 3 4 PASS

lfs mirror verify: '/mnt/testfs/file2' chunk [0xa00000, 0x1000000]
exceeds file size 0xa00000: skipped

The following command uses the --only option to only verify the specified mirrors:

# lfs mirror verify -v --only 1,4 /mnt/testfs/file2
CRC-32 checksum value for chunk [0, 0x200000):
Mirror 1:      0x207b02f1
Mirror 4:      0x207b02f1

CRC-32 checksum value for chunk [0x200000, 0x400000):
Mirror 1:      0x207b02f1
Mirror 4:      0x207b02f1

CRC-32 checksum value for chunk [0x400000, 0x600000):
Mirror 1:      0x42571b66
Mirror 4:      0xabdaf92

lfs mirror verify: chunk [0x400000, 0x600000) has different
checksum value on mirror 1 and mirror 4.
CRC-32 checksum value for chunk [0x600000, 0x800000):
Mirror 1:      0x1f8ad0d8
Mirror 4:      0x18975bf9

lfs mirror verify: chunk [0x600000, 0x800000) has different
checksum value on mirror 1 and mirror 4.
CRC-32 checksum value for chunk [0x800000, 0xa00000):
Mirror 1:      0x69c17478
Mirror 4:      0x69c17478

lfs mirror verify: '/mnt/testfs/file2' chunk [0xa00000, 0x1000000]
exceeds file size 0xa00000: skipped

```

22.2.6. Finding Mirrored File(s)

The `lfs find` command is used to list files and directories with specific attributes. The following two attribute parameters are specific to a mirrored file or directory:

```

lfs find <directory|filename ...>
    [[]] --mirror-count|-N [+]-n]
    [[]] --mirror-state <[^]state>]

```

Option	Description
--mirror-count -N [+]-n]	Indicates mirror count.

Option	Description
<code>--mirror-state <[^]state></code>	<p>Indicates mirrored file state.</p> <p>If <code>^state</code> is used, print only files not matching <code>state</code>. Only one state can be specified.</p> <p>Valid state names are:</p> <p><code>ro</code> – indicates the mirrored file is in read-only state. All of the mirrors contain the up-to-date data.</p> <p><code>wp</code> – indicates the mirrored file is in a state of being written.</p> <p><code>sp</code> – indicates the mirrored file is in a state of being resynchronized.</p>

Note:

Specifying `!` before an option negates its meaning (files NOT matching the parameter). Using `+` before a numeric value means 'more than n', while `-` before a numeric value means 'less than n'. If neither is used, it means 'equal to n', within the bounds of the unit specified (if any).

Examples:

The following command recursively lists all mirrored files that have more than 2 mirrors under directory `/mnt/testfs`:

```
# lfs find --mirror-count +2 --type f /mnt/testfs
```

The following command recursively lists all out-of-sync mirrored files under directory `/mnt/testfs`:

```
# lfs find --mirror-state=^ro --type f /mnt/testfs
```

22.3. Interoperability

Introduced in Lustre release 2.11.0, the FLR feature is based on the Section 19.5, “Progressive File Layout(PFL)” feature introduced in Lustre 2.10.0

For Lustre release 2.9 and older clients, which do not understand the PFL layout, they cannot access and open mirrored files created in the Lustre 2.11 filesystem.

The following example shows the errors returned by accessing and opening a mirrored file (created in Lustre 2.11 filesystem) on a Lustre 2.9 client:

```
# ls /mnt/testfs/mirrored_file
ls: cannot access /mnt/testfs/mirrored_file: Invalid argument
```

```
# cat /mnt/testfs/mirrored_file
cat: /mnt/testfs/mirrored_file: Operation not supported
```

For Lustre release 2.10 clients, which understand the PFL layout, but do not understand a mirrored layout, they can access mirrored files created in Lustre 2.11 filesystem, however,

they cannot open them. This is because the Lustre 2.10 clients do not verify overlapping components so they would read and write mirrored files just as if they were normal PFL files, which will cause a problem where synced mirrors actually contain different data.

The following example shows the results returned by accessing and opening a mirrored file (created in Lustre 2.11 filesystem) on a Lustre 2.10 client:

```
# ls /mnt/testfs/mirrored_file
/mnt/testfs/mirrored_file

# cat /mnt/testfs/mirrored_file
cat: /mnt/testfs/mirrored_file: Operation not supported
```

Chapter 23. Managing the File System and I/O

23.1. Handling Full OSTs

Sometimes a Lustre file system becomes unbalanced, often due to incorrectly-specified stripe settings, or when very large files are created that are not striped over all of the OSTs. Lustre will automatically avoid allocating new files on OSTs that are full. If an OST is completely full and more data is written to files already located on that OST, an error occurs. The procedures below describe how to handle a full OST.

The MDS will normally handle space balancing automatically at file creation time, and this procedure is normally not needed, but manual data migration may be desirable in some cases (e.g. creating very large files that would consume more than the total free space of the full OSTs).

23.1.1. Checking OST Space Usage

The example below shows an unbalanced file system:

```
client# lfs df -h
UUID                               bytes          Used          Available    \
Use%                               Mounted on
testfs-MDT0000_UUID                4.4G           214.5M        3.9G         \
4%                                  /mnt/testfs[MDT:0]
testfs-OST0000_UUID                2.0G           751.3M        1.1G         \
37%                                  /mnt/testfs[OST:0]
testfs-OST0001_UUID                2.0G           755.3M        1.1G         \
37%                                  /mnt/testfs[OST:1]
testfs-OST0002_UUID                2.0G           1.7G          155.1M       \
86%                                  /mnt/testfs[OST:2] ****
testfs-OST0003_UUID                2.0G           751.3M        1.1G         \
37%                                  /mnt/testfs[OST:3]
testfs-OST0004_UUID                2.0G           747.3M        1.1G         \
37%                                  /mnt/testfs[OST:4]
testfs-OST0005_UUID                2.0G           743.3M        1.1G         \
36%                                  /mnt/testfs[OST:5]

filesystem summary:                11.8G          5.4G          5.8G         \
45%                                  /mnt/testfs
```

In this case, OST0002 is almost full and when an attempt is made to write additional information to the file system (even with uniform striping over all the OSTs), the write command fails as follows:

```
client# lfs setstripe /mnt/testfs 4M 0 -1
client# dd if=/dev/zero of=/mnt/testfs/test_3 bs=10M count=100
dd: writing '/mnt/testfs/test_3': No space left on device
98+0 records in
97+0 records out
1017192448 bytes (1.0 GB) copied, 23.2411 seconds, 43.8 MB/s
```

23.1.2. Disabling creates on a Full OST

To avoid running out of space in the file system, if the OST usage is imbalanced and one or more OSTs are close to being full while there are others that have a lot of space, the MDS will typically avoid file creation on the full OST(s) automatically. The full OSTs may optionally be deactivated manually on the MDS to ensure the MDS will not allocate new objects there.

1. Log into the MDS server and use the `lctl` command to stop new object creation on the full OST(s):

```
mds# lctl set_param osp.fssize-OSTnnnn*.max_create_count=0
```

When new files are created in the file system, they will only use the remaining OSTs. Either manual space rebalancing can be done by migrating data to other OSTs, as shown in the next section, or normal file deletion and creation can passively rebalance the space usage.

23.1.3. Migrating Data within a File System

If there is a need to move the file data from the current OST(s) to new OST(s), the data must be migrated (copied) to the new location. The simplest way to do this is to use the `lfs_migrate` command, as described in Section 14.8, “Adding a New OST to a Lustre File System”.

23.1.4. Returning an Inactive OST Back Online

Once the full OST(s) no longer are severely imbalanced, due to either active or passive data redistribution, they should be reactivated so they will again have new files allocated on them.

```
[mgs]# lctl set_param osp.testfs-OST0002.max_create_count=20000
```

23.1.5. Migrating Metadata within a Filesystem

Introduced in Lustre 2.8

23.1.5.1. Whole Directory Migration

Lustre software version 2.8 includes a feature to migrate metadata (directories and inodes therein) between MDTs. This migration can only be performed on whole directories. Striped directories are not supported until Lustre 2.12. For example, to migrate the contents of the `/testfs/remotedir` directory from the MDT where it currently is located to MDT0000 to allow that MDT to be removed, the sequence of commands is as follows:

```
$ cd /testfs
$ lfs getdirstripe -m ./remotedir which MDT is dir on?
1
$ touch ./remotedir/file.{1,2,3}.txtcreate test files
$ lfs getstripe -m ./remotedir/file.*.txtcheck files are on MDT0001
1
1
1
1
$ lfs migrate -m 0 ./remotedir migrate testremote to MDT0000
$ lfs getdirstripe -m ./remotedir which MDT is dir on now?
0
```

```
$ lfs getstripe -m ./remotedir/file.*.txtcheck files are on MDT0000
0
0
0
```

For more information, see `man lfs-migrate`.

Warning

During migration each file receives a new identifier (FID). As a consequence, the file will report a new inode number to userspace applications. Some system tools (for example, backup and archiving tools, NFS, Samba) that identify files by inode number may consider the migrated files to be new, even though the contents are unchanged. If a Lustre system is re-exporting to NFS, the migrated files may become inaccessible during and after migration if the client or server are caching a stale file handle with the old FID. Restarting the NFS service will flush the local file handle cache, but clients may also need to be restarted as they may cache stale file handles as well.

Introduced in Lustre 2.12

23.1.5.2. Striped Directory Migration

Lustre 2.8 included a feature to migrate metadata (directories and inodes therein) between MDTs, however it did not support migration of striped directories, or changing the stripe count of an existing directory. Lustre 2.12 adds support for migrating and restriping directories. The `lfs migrate -m` command can only be performed on whole directories, though it will migrate both the specified directory and its sub-entries recursively. For example, to migrate the contents of a large directory `/testfs/largedir` from its current location on MDT0000 to MDT0001 and MDT0003, run the following command:

```
$ lfs migrate -m 1,3 /testfs/largedir
```

Metadata migration will migrate file dirent and inode to other MDTs, but it won't touch file data. During migration, directory and its sub-files can be accessed like normal ones, though the same warning above applies to tools that depend on the file inode number. Migration may fail for various reasons such as MDS restart, or disk full. In those cases, some of the sub-files may have been migrated to the new MDTs, while others are still on the original MDT. The files can be accessed normally. The same `lfs migrate -m` command should be executed again when these issues are fixed to finish this migration. However, you cannot abort a failed migration, or migrate to different MDTs from previous migration command.

Introduced in Lustre 2.12

23.1.5.3. Directory Restriping

Lustre 2.14 includes a feature to change the stripe count of an existing directory. The `lfs setdirstripe -c` command can be performed on an existing directory to change its stripe count. For example, a directory `/testfs/testdir` is becoming large, run the following command to increase its stripe count to 2:

```
$ lfs setdirstripe -c 2 /testfs/testdir
```

By default directory restriping will migrate sub-file dirents only, but it won't move inodes. To enable moving both dirents and inodes, run the following command on all MDS's:

```
mds$ lctl set_param mdt.*.dir_restripe_nsonly=0
```

It's not allowed to specify MDTs in directory restriping, instead server will pick MDTs for the added stripes by space and inode usages. During restriping, directory and its sub-files can be accessed like normal ones,

which is the same as directory migration. Similarly you cannot abort a failed restriping, and server will resume the failed restriping automatically when it notices an unfinished restriping.

Introduced in Lustre 2.12

23.1.5.4. Directory Auto-Split

Lustre 2.14 includes a feature to automatically increase the stripe count of a directory when it becomes large. This can be enabled by the following command:

```
mds$ lctl set_param mdt.*.enable_dir_auto_split=1
```

The sub file count that triggers directory auto-split is 50k, and it can be changed by the following command:

```
mds$ lctl set_param mdt.*.dir_split_count=value
```

The directory stripe count will be increased from 0 to 4 if it's a plain directory, and from 4 to 8 upon the second split, and so on. However the final stripe count won't exceed total MDT count, and it will stop splitting when it's distributed among all MDTs. This delta value can be changed by the following command:

```
mds$ lctl set_param mdt.*.dir_split_delta=value
```

23.2. Creating and Managing OST Pools

The OST pools feature enables users to group OSTs together to make object placement more flexible. A 'pool' is the name associated with an arbitrary subset of OSTs in a Lustre cluster.

OST pools follow these rules:

- An OST can be a member of multiple pools.
- No ordering of OSTs in a pool is defined or implied.
- Stripe allocation within a pool follows the same rules as the normal stripe allocator.
- OST membership in a pool is flexible, and can change over time.

When an OST pool is defined, it can be used to allocate files. When file or directory striping is set to a pool, only OSTs in the pool are candidates for striping. If a `stripe_index` is specified which refers to an OST that is not a member of the pool, an error is returned.

OST pools are used only at file creation. If the definition of a pool changes (an OST is added or removed or the pool is destroyed), already-created files are not affected.

Note

An error (`EINVAL`) results if you create a file using an empty pool.

Note

If a directory has pool striping set and the pool is subsequently removed, the new files created in this directory have the (non-pool) default striping pattern for that directory applied and no error is returned.

23.2.1. Working with OST Pools

OST pools are defined in the configuration log on the MGS. Use the `lctl` command to:

- Create/destroy a pool
- Add/remove OSTs in a pool
- List pools and OSTs in a specific pool

The `lctl` command **MUST** be run on the MGS. Another requirement for managing OST pools is to either have the MDT and MGS on the same node or have a Lustre client mounted on the MGS node, if it is separate from the MDS. This is needed to validate the pool commands being run are correct.

Caution

Running the `writeconf` command on the MDS erases all pools information (as well as any other parameters set using `lctl conf_param`). We recommend that the pools definitions (and `conf_param` settings) be executed using a script, so they can be reproduced easily after a `writeconf` is performed.

To create a new pool, run:

```
mgs# lctl pool_new fsname.poolname
```

Note

The pool name is an ASCII string up to 15 characters.

To add the named OST to a pool, run:

```
mgs# lctl pool_add fsname.poolname ost_list
```

Where:

- *ost_list* is *fsname-OST index_range*
- *index_range* is *ost_index_start- ost_index_end[,index_range]* or *ost_index_start- ost_index_end/step*

If the leading *fsname* and/or ending *_UUID* are missing, they are automatically added.

For example, to add even-numbered OSTs to `pool1` on file system `testfs`, run a single command (`pool_add`) to add many OSTs to the pool at one time:

```
lctl pool_add testfs.pool1 OST[0-10/2]
```

Note

Each time an OST is added to a pool, a new `llog` configuration record is created. For convenience, you can run a single command.

To remove a named OST from a pool, run:

```
mgs# lctl pool_remove
fsname.
poolname
ost_list
```

To destroy a pool, run:

```
mgs# lctl pool_destroy
fsname.
poolname
```

Note

All OSTs must be removed from a pool before it can be destroyed.

To list pools in the named file system, run:

```
mgs# lctl pool_list
fsname/pathname
```

To list OSTs in a named pool, run:

```
lctl pool_list
fsname.
poolname
```

23.2.1.1. Using the lfs Command with OST Pools

Several `lfs` commands can be run with OST pools. Use the `lfs setstripe` command to associate a directory with an OST pool. This causes all new regular files and directories in the directory to be created in the pool. The `lfs` command can be used to list pools in a file system and OSTs in a named pool.

To associate a directory with a pool, so all new files and directories will be created in the pool, run:

```
client# lfs setstripe --pool|-p pool_name
filename/dirname
```

To set striping patterns, run:

```
client# lfs setstripe [--size|-s stripe_size] [--offset|-o start_ost]
      [--stripe-count|-c stripe_count] [--overstripe-count|-C stripe_count]
      [--pool|-p pool_name]
```

```
dir/filename
```

Note

If you specify striping with an invalid pool name, because the pool does not exist or the pool name was mistyped, `lfs setstripe` returns an error. Run `lfs pool_list` to make sure the pool exists and the pool name is entered correctly.

Note

The `--pool` option for `lfs setstripe` is compatible with other modifiers. For example, you can set striping on a directory to use an explicit starting index.

Introduced in Lustre 2.16

Note

There are several reserved pool keywords:

- Use `--pool ''` or `--pool inherit` to force a component to inherit the pool from the parent or root directory instead of the previous PFL's component (see Section 19.5, “Progressive File Layout(PFL)”).
- Use `--pool ignore` to force creation of a file or a PFL's component without a pool set (no inheritance from last component, root or parent).

23.2.2. Tips for Using OST Pools

Here are several suggestions for using OST pools.

- A directory or file can be given an extended attribute (EA), that restricts striping to a pool.
- Pools can be used to group OSTs with the same technology or performance (slower or faster), or that are preferred for certain jobs. Examples are SATA OSTs versus SAS OSTs or remote OSTs versus local OSTs.
- A file created in an OST pool tracks the pool by keeping the pool name in the file LOV EA.

23.3. Adding an OST to a Lustre File System

To add an OST to existing Lustre file system:

1. Add a new OST by passing on the following commands, run:

```
oss# mkfs.lustre --fsname=testfs --mgsnode=mds16@tcp0 --ost --index=12 /dev/sda
oss# mkdir -p /mnt/testfs/ost12
oss# mount -t lustre /dev/sda /mnt/testfs/ost12
```

2. Migrate the data (possibly).

The file system is quite unbalanced when new empty OSTs are added. New file creations are automatically balanced. If this is a scratch file system or files are pruned at a regular interval, then no further work may be needed. Files existing prior to the expansion can be rebalanced with an in-place copy, which can be done with a simple script.

The basic method is to copy existing files to a temporary file, then move the temp file over the old one. This should not be attempted with files which are currently being written to by users or applications. This operation redistributes the stripes over the entire set of OSTs.

A very clever migration script would do the following:

- Examine the current distribution of data.
- Calculate how much data should move from each full OST to the empty ones.
- Search for files on a given full OST (using `lfs getstripe`).
- Force the new destination OST (using `lfs setstripe`).
- Copy only enough files to address the imbalance.

If a Lustre file system administrator wants to explore this approach further, per-OST disk-usage statistics can be found in the `osc.*.rpc_stats` parameter file.

23.4. Performing Direct I/O

The Lustre software supports the `O_DIRECT` flag to open.

Applications using the `read()` and `write()` calls must supply buffers aligned on a page boundary (usually 4 K). If the alignment is not correct, the call returns `-EINVAL`. Direct I/O may help performance in cases where the client is doing a large amount of I/O and is CPU-bound (CPU utilization 100%).

23.4.1. Making File System Objects Immutable

An immutable file or directory is one that cannot be modified, renamed or removed. To do this:

```
chattr +i
file
```

To remove this flag, use `chattr -i`

23.5. Other I/O Options

This section describes other I/O options, including checksums, and the `ptlrpcd` thread pool.

23.5.1. Lustre Checksums

To guard against network data corruption, a Lustre client can perform two types of data checksums: in-memory (for data in client memory) and wire (for data sent over the network). For each checksum type, a 32-bit checksum of the data read or written on both the client and server is computed, to ensure that the data has not been corrupted in transit over the network. The `ldiskfs` backing file system does NOT do any persistent checksumming, so it does not detect corruption of data in the OST file system.

The checksumming feature is enabled, by default, on individual client nodes. If the client or OST detects a checksum mismatch, then an error is logged in the `syslog` of the form:

```
LustreError: BAD WRITE CHECKSUM: changed in transit before arrival at OST: \
from 192.168.1.1@tcp inum 8991479/2386814769 object 1127239/0 extent [10240\
0-106495]
```

If this happens, the client will re-read or re-write the affected data up to five times to get a good copy of the data over the network. If it is still not possible, then an I/O error is returned to the application.

To enable both types of checksums (in-memory and wire), run:

```
lctl set_param llite.*.checksum_pages=1
```

To disable both types of checksums (in-memory and wire), run:

```
lctl set_param llite.*.checksum_pages=0
```

To check the status of a wire checksum, run:

```
lctl get_param osc.*.checksums
```

23.5.1.1. Changing Checksum Algorithms

By default, the Lustre software uses the `adler32` checksum algorithm, because it is robust and has a lower impact on performance than `crc32`. The Lustre file system administrator can change the checksum algorithm via `lctl get_param`, depending on what is supported in the kernel.

To check which checksum algorithm is being used by the Lustre software, run:

```
$ lctl get_param osc.*.checksum_type
```

To change the wire checksum algorithm, run:

```
$ lctl set_param osc.*.checksum_type=  
algorithm
```

Note

The in-memory checksum always uses the `adler32` algorithm, if available, and only falls back to `crc32` if `adler32` cannot be used.

In the following example, the `lctl get_param` command is used to determine that the Lustre software is using the `adler32` checksum algorithm. Then the `lctl set_param` command is used to change the checksum algorithm to `crc32`. A second `lctl get_param` command confirms that the `crc32` checksum algorithm is now in use.

```
$ lctl get_param osc.*.checksum_type  
osc.testfs-OST0000-osc-ffff81012b2c48e0.checksum_type=adler32 [adler]  
$ lctl set_param osc.*.checksum_type=crc32  
osc.testfs-OST0000-osc-ffff81012b2c48e0.checksum_type=crc32  
$ lctl get_param osc.*.checksum_type  
osc.testfs-OST0000-osc-ffff81012b2c48e0.checksum_type=[crc32] adler
```

23.5.2. PtIRPC Client Thread Pool

The use of large SMP nodes for Lustre clients requires significant parallelism within the kernel to avoid cases where a single CPU would be 100% utilized and other CPUs would be relatively idle. This is especially noticeable when a single thread traverses a large directory.

The Lustre client implements a PtIRPC daemon thread pool, so that multiple threads can be created to serve asynchronous RPC requests, even if only a single userspace thread is running. The number of ptlrpd threads spawned is controlled at module load time using module options. By default two service threads are spawned per CPU socket.

One of the issues with thread operations is the cost of moving a thread context from one CPU to another with the resulting loss of CPU cache warmth. To reduce this cost, PtIRPC threads can be bound to a CPU. However, if the CPUs are busy, a bound thread may not be able to respond quickly, as the bound CPU may be busy with other tasks and the thread must wait to schedule.

Because of these considerations, the pool of ptlrpd threads can be a mixture of bound and unbound threads. The system operator can balance the thread mixture based on system size and workload.

23.5.2.1. ptlrpd parameters

These parameters should be set in `/etc/modprobe.conf` or in the `etc/modprobe.d` directory, as options for the ptlrpd module.

```
options ptlrpd ptlrpd_per_cpt_max=XXX
```

Sets the number of ptlrpd threads created per socket. The default if not specified is two threads per CPU socket, including hyper-threaded CPUs. The lower bound is 2 threads per socket.

```
options ptlrpd ptlrpd_bind_policy=[1-4]
```

Controls the binding of threads to CPUs. There are four policy options.

- `PDB_POLICY_NONE`(`ptlrpd_bind_policy=1`) All threads are unbound.
- `PDB_POLICY_FULL`(`ptlrpd_bind_policy=2`) All threads attempt to bind to a CPU.
- `PDB_POLICY_PAIR`(`ptlrpd_bind_policy=3`) This is the default policy. Threads are allocated as a bound/unbound pair. Each thread (bound or free) has a partner thread. The partnering is used by the ptlrpd load policy, which determines how threads are allocated to CPUs.
- `PDB_POLICY_NEIGHBOR`(`ptlrpd_bind_policy=4`) Threads are allocated as a bound/unbound pair. Each thread (bound or free) has two partner threads.

Chapter 24. Lustre File System Failover and Multiple-Mount Protection

This chapter describes the multiple-mount protection (MMP) feature, which protects the file system from being mounted simultaneously to more than one node. It includes the following sections:

- Section 24.1, “Overview of Multiple-Mount Protection”
- Section 24.2, “Working with Multiple-Mount Protection”

Note

For information about configuring a Lustre file system for failover, see Chapter 11, *Configuring Failover in a Lustre File System*

24.1. Overview of Multiple-Mount Protection

The multiple-mount protection (MMP) feature protects the Lustre file system from being mounted simultaneously to more than one node. This feature is important in a shared storage environment (for example, when a failover pair of OSSs share a LUN).

The backend file system, `ldiskfs`, supports the MMP mechanism. A block in the file system is updated by a `kmmkd` daemon at one second intervals, and a sequence number is written in this block. If the file system is cleanly unmounted, then a special "clean" sequence is written to this block. When mounting the file system, `ldiskfs` checks if the MMP block has a clean sequence or not.

Even if the MMP block has a clean sequence, `ldiskfs` waits for some interval to guard against the following situations:

- If I/O traffic is heavy, it may take longer for the MMP block to be updated.
- If another node is trying to mount the same file system, a "race" condition may occur.

With MMP enabled, mounting a clean file system takes at least 10 seconds. If the file system was not cleanly unmounted, then the file system mount may require additional time.

Note

The MMP feature is only supported on Linux kernel versions newer than 2.6.9.

24.2. Working with Multiple-Mount Protection

On a new Lustre file system, MMP is automatically enabled by `mkfs.lustre` at format time if failover is being used and the kernel and `e2fsprogs` version support it. On an existing file system, a Lustre file system administrator can manually enable MMP when the file system is unmounted.

Use the following commands to determine whether MMP is running in the Lustre file system and to enable or disable the MMP feature.

To determine if MMP is enabled, run:

```
dumpe2fs -h /dev/block_device | grep mmp
```

Here is a sample command:

```
dumpe2fs -h /dev/sdc | grep mmp
Filesystem features: has_journal ext_attr resize_inode dir_index
filetype extent mmp sparse_super large_file uninit_bg
```

To manually disable MMP, run:

```
tune2fs -O ^mmp /dev/block_device
```

To manually enable MMP, run:

```
tune2fs -O mmp /dev/block_device
```

When MMP is enabled, if `ldiskfs` detects multiple mount attempts after the file system is mounted, it blocks these later mount attempts and reports the time when the MMP block was last updated, the node name, and the device name of the node where the file system is currently mounted.

Chapter 25. Configuring and Managing Quotas

25.1. Working with Quotas

Quotas allow a system administrator to limit the amount of disk space a user, group, or project can use. Quotas are set by root, and can be specified for individual users, groups, and/or projects. Before a file is written to a partition where quotas are set, the quota of the creator's group is checked. If a quota exists, then the file size counts towards the group's quota. If no quota exists, then the owner's user quota is checked before the file is written. Similarly, inode usage for specific functions can be controlled if a user over-uses the allocated space.

Lustre quota enforcement differs from standard Linux quota enforcement in several ways:

- Quotas are administered via the `lfs` and `lctl` commands (post-mount).
- The quota feature in Lustre software is distributed throughout the system (as the Lustre file system is a distributed file system). Because of this, quota setup and behavior on Lustre is somewhat different from local disk quotas in the following ways:
 - No single point of administration: some commands must be executed on the MGS, other commands on the MDSs and OSSs, and still other commands on the client.
 - Granularity: a local quota is typically specified for kilobyte resolution, Lustre uses one megabyte as the smallest quota resolution.
 - Accuracy: quota information is distributed throughout the file system and can only be accurately calculated with a quiescent file system in order to minimize performance overhead during normal use.
- Quotas are allocated and consumed in a quantized fashion.
- Client does not set the `usrquota` or `grpquota` options to mount. Space accounting is enabled by default and quota enforcement can be enabled/disabled on a per-filesystem basis with `lctl set_param -P`.

Introduced in Lustre 2.8

It is worth noting that the `lfs quotaon`, `lfs quotaoff`, `lfs quotacheck` and `quota_type` sub-commands are deprecated as of Lustre 2.4.0, and removed completely in Lustre 2.8.0.

Caution

Although a quota feature is available in the Lustre software, root quotas are NOT enforced.

```
lfs setquota -u root (limits are not enforced)
```

```
lfs quota -u root (usage includes internal Lustre data that is dynamic in size and does not accurately reflect mount point visible block and inode usage).
```

25.2. Enabling Disk Quotas

The design of quotas on Lustre has management and enforcement separated from resource usage and accounting. Lustre software is responsible for management and enforcement. The back-end file system is

responsible for resource usage and accounting. Because of this, it is necessary to begin enabling quotas by enabling quotas on the back-end disk system.

Caution

Quota setup is orchestrated by the MGS and *all setup commands in this section must be run directly on the MGS*. Support for project quotas specifically requires Lustre Release 2.10 or later. A *patched server* may be required, depending on the kernel version and backend filesystem type:

Configuration	Patched Server Required?
<i>ldiskfs with kernel version < 4.5</i>	Yes
<i>ldiskfs with kernel version >= 4.5</i>	No
<i>zfs version >=0.8 with kernel version < 4.5</i>	Yes
<i>zfs version >=0.8 with kernel version > 4.5</i>	No

*Note: Project quotas are not supported on zfs versions earlier than 0.8.

Once setup, verification of the quota state must be performed on the MDT. Although quota enforcement is managed by the Lustre software, each OSD implementation relies on the back-end file system to maintain per-user/group/project block and inode usage. Hence, differences exist when setting up quotas with `ldiskfs` or ZFS back-ends:

- For `ldiskfs` backends, `mkfs.lustre` now creates empty quota files and enables the QUOTA feature flag in the superblock which turns quota accounting on at mount time automatically. `e2fsck` was also modified to fix the quota files when the QUOTA feature flag is present. The project quota feature is disabled by default, and `tune2fs` needs to be run to enable every target manually. If user, group, and project quota usage is inconsistent, run `e2fsck -f` on all unmounted MDTs and OSTs.
- For ZFS backend, *the project quota feature is not supported on zfs versions less than 0.8.0*. Accounting ZAPs are created and maintained by the ZFS file system itself. While ZFS tracks per-user and group block usage, it does not handle inode accounting for ZFS versions prior to `zfs-0.7.0`. The ZFS OSD previously implemented its own support for inode tracking. Two options are available:
 1. The ZFS OSD can estimate the number of inodes in-use based on the number of blocks used by a given user or group. This mode can be enabled by running the following command on the server running the target: `lctl set_param osd-zfs.${FSNAME}-${TARGETNAME}.quota_iused_estimate=1`.
 2. Similarly to block accounting, dedicated ZAPs are also created the ZFS OSD to maintain per-user and group inode usage. This is the default mode which corresponds to `quota_iused_estimate` set to 0.

Note

To (re-)enable space usage quota on `ldiskfs` filesystems, run `tune2fs -O quota` against all targets. This command sets the QUOTA feature flag in the superblock and runs `e2fsck` internally. As a result, the target must be offline to build the per-UID/GID disk usage database.

Introduced in Lustre 2.10

Lustre filesystems formatted with a Lustre release prior to 2.10 can be still safely upgraded to release 2.10, but will not have project quota usage reporting functional until 2.15.0 or `tune2fs -O project` is run against all `ldiskfs` backend targets. This command sets the PROJECT feature flag in the superblock and runs `e2fsck` (as a result, the target must

be offline). See Section 25.6, “Quotas and Version Interoperability” for further important considerations.

Caution

Lustre requires a version of e2fsprogs that supports quota to be installed on the server nodes when using the ldiskfs backend (e2fsprogs is not needed with ZFS backend). In general, we recommend to use the latest e2fsprogs version available on <https://downloads.whamcloud.com/public/e2fsprogs/> [<https://downloads.whamcloud.com/public/e2fsprogs/>].

The ldiskfs OSD relies on the standard Linux quota to maintain accounting information on disk. As a consequence, the Linux kernel running on the Lustre servers using ldiskfs backend must have CONFIG_QUOTA, CONFIG_QUOTACTL and CONFIG_QFMT_V2 enabled.

Quota enforcement is turned on/off independently of space accounting which is always enabled. There is a single per-file system quota parameter controlling inode/block quota enforcement. Like all permanent parameters, this quota parameter can be set via `lctl set_param -P` on the MGS via the command:

```
lctl set_param -P osd-*.fsname-*.quota_slave_md/dt.enabled=u/g/p/none
```

- dt -- to configure data/block quota managed by OSTs (and MDTs for DoM files)
- md -- to configure metadata/inode quota managed by MDTs
- u -- to enable quota enforcement for users only
- g -- to enable quota enforcement for groups only
- p -- to enable quota enforcement for projects only
- ug -- to enable quota enforcement for all users and groups
- ugp -- to enable quota enforcement for all users, groups, and projects
- none -- to disable quota enforcement for all users, groups and projects

Examples:

To turn on user, group, and project quotas for block only on file system `testfs1`, *on the MGS* run:

```
mgs# lctl set_param -P osd-*.testfs1*.quota_slave_dt.enabled=ugp
```

To turn on only group quotas for inodes on file system `testfs2`, *on the MGS* run:

```
mgs# lctl set_param -P osd*.testfs2*.quota_slave_md.enabled=g
```

To turn off user, group, and project quotas for both inode and block on file system `testfs3`, *on the MGS* run:

```
mgs# lctl set_param -P osd*.testfs3*.quota*.enabled=none
```

25.2.1. Quota Verification

Once the quota parameters have been configured, all targets which are part of the file system will be automatically notified of the new quota settings and enable/disable quota enforcement as needed. The per-target enforcement status can still be verified by running the following *command on the servers*:

```
$ lctl get_param osd-*.*.quota_slave_*.enabled
osd-zfs.testfs1-MDT0000.quota_slave_dt.enabled=ugp
osd-zfs.testfs1-OST0000.quota_slave_dt.enabled=ugp
```

25.3. Quota Administration

Once the file system is up and running, quota limits on blocks and inodes can be set for user, group, and project. This is *controlled entirely from a client* via three quota parameters:

Grace period-- The period of time (in seconds) within which users are allowed to exceed their soft limit. There are six types of grace periods:

- user block soft limit
- user inode soft limit
- group block soft limit
- group inode soft limit
- project block soft limit
- project inode soft limit

The grace period applies to all users. The user block soft limit is for all users who are using a blocks quota.

Soft limit -- The grace timer is started once the soft limit is exceeded. At this point, the user/group/project can still allocate block/inode. When the grace time expires and if the user is still above the soft limit, the soft limit becomes a hard limit and the user/group/project can't allocate any new block/inode any more. The user/group/project should then delete files to be under the soft limit. The soft limit **MUST** be smaller than the hard limit. If the soft limit is not needed, it should be set to zero (0).

Hard limit -- Block or inode allocation will fail with EDQUOT(i.e. quota exceeded) when the hard limit is reached. The hard limit is the absolute limit. When a grace period is set, one can exceed the soft limit within the grace period if under the hard limit.

Due to the distributed nature of a Lustre file system and the need to maintain performance under load, those quota parameters may not be 100% accurate. The quota settings can be manipulated via the `lfs` command, executed on a client, and includes several options to work with quotas:

- `quota` -- displays general quota information (disk usage and limits)
- `setquota` -- specifies quota limits and tunes the grace period. By default, the grace period is one week.

Usage:

```
lfs quota [-q] [-v] [-h] [-o obd_uuid] [-u|-g|-p uname/uid/gname/gid/projid] /mount
lfs quota -t {-u|-g|-p} /mount_point
lfs setquota {-u|--user|-g|--group|-p|--project} username/groupname [-b block-soft
            [-B block_hardlimit] [-i inode_softlimit] \
            [-I inode_hardlimit] /mount_point
```

To display general quota information (disk usage and limits) for the user running the command and his primary group, run:

```
$ lfs quota /mnt/testfs
```

To display general quota information for a specific user (" bob" in this example), run:

```
$ lfs quota -u bob /mnt/testfs
```

To display general quota information for a specific user (" bob" in this example) and detailed quota statistics for each MDT and OST, run:

```
$ lfs quota -u bob -v /mnt/testfs
```

To display general quota information for a specific project (" 1" in this example), run:

```
$ lfs quota -p 1 /mnt/testfs
```

To display general quota information for a specific group (" eng" in this example), run:

```
$ lfs quota -g eng /mnt/testfs
```

To limit quota usage for a specific project ID on a specific directory ("/mnt/testfs/dir" in this example), run:

```
$ lfs project -s -p 1 -r /mnt/testfs/dir
$ lfs setquota -p 1 -b 307200 -B 309200 -i 10000 -I 11000 /mnt/testfs
```

Recursively list all descendants'(of the directory) project attribute on directory ("/mnt/testfs/dir" in this example), run:

```
$ lfs project -r /mnt/testfs/dir
```

Please note that if it is desired to have `lfs quota -p` show the space/inode usage under the directory properly (much faster than `du`), then the user/admin needs to use different project IDs for different directories.

To display block and inode grace times for user quotas, run:

```
$ lfs quota -t -u /mnt/testfs
```

To set user or group quotas for a specific ID ("bob" in this example), run:

```
$ lfs setquota -u bob -b 307200 -B 309200 -i 10000 -I 11000 /mnt/testfs
```

In this example, the quota for user "bob" is set to 300 MB (309200*1024) and the hard limit is 11,000 files. Therefore, the inode hard limit should be 11000.

The quota command displays the quota allocated and consumed by each Lustre target. Using the previous `setquota` example, running this `lfs quota` command:

```
$ lfs quota -u bob -v /mnt/testfs
```

displays this command output:

```
Disk quotas for user bob (uid 6000):
Filesystem          kbytes quota limit grace files quota limit grace
/mnt/testfs         0      30720 30920 -    0      10000 11000 -
testfs-MDT0000_UUID 0        -      8192 -    0        -      2560 -
testfs-OST0000_UUID 0        -      8192 -    0        -      0 -
testfs-OST0001_UUID 0        -      8192 -    0        -      0 -
Total allocated inode limit: 2560, total allocated block limit: 24576
```

Global quota limits are stored in dedicated index files (there is one such index per quota type) on the quota master target (aka QMT). The QMT runs on MDT0000 and exports the global indices via `lctl get_param`. The global indices can thus be dumped via the following command:

```
# lctl get_param qmt.testfs-QMT0000.*.glb*
```

The format of global indexes depends on the OSD type. The `ldiskfs` OSD uses an IAM files while the `ZFS` OSD creates dedicated ZAPs.

Each slave also stores a copy of this global index locally. When the global index is modified on the master, a glimpse callback is issued on the global quota lock to notify all slaves that the global index has been modified. This glimpse callback includes information about the identifier subject to the change. If the global index on the QMT is modified while a slave is disconnected, the index version is used to determine whether the slave copy of the global index isn't up to date any more. If so, the slave fetches the whole index again and updates the local copy. The slave copy of the global index can also be accessed via the following command:

```
lctl get_param osd-*.*.quota_slave.limit*
```

Introduced in Lustre 2.12

25.4. Default Quota

The default quota is used to enforce the quota limits for any user, group, or project that do not have quotas set by administrator.

The default quota can be disabled by setting limits to 0.

25.4.1. Usage

```
lfs quota [-U|--default-usr|-G|--default-grp|-P|--default-prj] /mount_point
lfs setquota {-U|--default-usr|-G|--default-grp|-P|--default-prj} [-b block-softli
          [-B block_hardlimit] [-i inode_softlimit] [-I inode_hardlimit] /mount
```

```
lfs setquota {-u|-g|-p} username/groupname --default /mount_point
```

To set the default user quota:

```
# lfs setquota -U -b 10G -B 11G -i 100K -I 105K /mnt/testfs
```

To set the default group quota:

```
# lfs setquota -G -b 10G -B 11G -i 100K -I 105K /mnt/testfs
```

To set the default project quota:

```
# lfs setquota -P -b 10G -B 11G -i 100K -I 105K /mnt/testfs
```

To disable the default user quota:

```
# lfs setquota -U -b 0 -B 0 -i 0 -I 0 /mnt/testfs
```

To disable the default group quota:

```
# lfs setquota -G -b 0 -B 0 -i 0 -I 0 /mnt/testfs
```

To disable the default project quota:

```
# lfs setquota -P -b 0 -B 0 -i 0 -I 0 /mnt/testfs
```

To set user 'bob' to use the default user quota:

```
# lfs setquota -u bob --default /mnt/testfs
```

To set group 'bob' to use the default group quota:

```
# lfs setquota -g bob --default /mnt/testfs
```

To set project 1000 to use the default project quota:

```
# lfs setquota -p 1000 --default /mnt/testfs
```

Note

If quota limits are set for some user, group or project, it will use those specific quota limits instead of the default quota. Quota limits for any user, group or project will use the default quota by setting its quota limits with option '--default'.

25.5. Quota Allocation

In a Lustre file system, quota must be properly allocated or users may experience unnecessary failures. The file system block quota is divided up among the OSTs within the file system. Each OST requests an allocation which is increased up to the quota limit. The quota allocation is then *quantized* to reduce the number of quota-related request traffic.

The Lustre quota system distributes quotas from the Quota Master Target (aka QMT). Only one QMT instance is supported for now and only runs on the same node as MDT0000. All OSTs and MDTs set up a Quota Slave Device (aka QSD) which connects to the QMT to allocate/release quota space. The QSD is setup directly from the OSD layer.

To reduce quota requests, quota space is initially allocated to QSDs in very large chunks. How much unused quota space can be held by a target is controlled by the qunit size. When quota space for a given ID is close to exhaustion on the QMT, the qunit size is reduced and QSDs are notified of the new qunit size value via a glimpse callback. Slaves are then responsible for releasing quota space above the new qunit value. The qunit size isn't shrunk indefinitely and there is a minimal value of 1MB for blocks and 1,024 for inodes. This means that the quota space rebalancing process will stop when this minimum value is reached. As a result, quota exceeded can be returned while many slaves still have 1MB or 1,024 inodes of spare quota space.

If we look at the `setquota` example again, running this `lfs quota` command:

```
# lfs quota -u bob -v /mnt/testfs
```

displays this command output:

```
Disk quotas for user bob (uid 500):
Filesystem      kbytes quota limit grace      files  quota limit grace
/mnt/testfs    30720* 30720 30920 6d23h56m44s 10101* 10000 11000
6d23h59m50s
testfs-MDT0000_UUID 0      -      0      -      10101  -      10240
testfs-OST0000_UUID 0      -      1024  -      -      -      -
testfs-OST0001_UUID 30720* -      29896  -      -      -      -
Total allocated inode limit: 10240, total allocated block limit: 30920
```

The total quota limit of 30,920 is allocated to user bob, which is further distributed to two OSTs.

Values appended with '*' show that the quota limit has been exceeded, causing the following error when trying to write or create a file:

```
$ cp: writing `/mnt/testfs/foo`: Disk quota exceeded.
```

Note

It is very important to note that the block quota is consumed per OST and the inode quota per MDS. Therefore, when the quota is consumed on one OST (resp. MDT), the client may not be able to create files regardless of the quota available on other OSTs (resp. MDTs).

Setting the quota limit below the minimal quinit size may prevent the user/group from all file creation. It is thus recommended to use soft/hard limits which are a multiple of the number of OSTs * the minimal quinit size.

To determine the total number of inodes, use `lfs df -i` (and also `lctl get_param *.*.filestotal`). For more information on using the `lfs df -i` command and the command output, see Section 19.8.1, “Checking File System Free Space”.

Unfortunately, the `statfs` interface does not report the free inode count directly, but instead reports the total inode and used inode counts. The free inode count is calculated for `df` from (total inodes - used inodes). It is not critical to know the total inode count for a file system. Instead, you should know (accurately), the free inode count and the used inode count for a file system. The Lustre software manipulates the total inode count in order to accurately report the other two values.

25.6. Quotas and Version Interoperability

Introduced in Lustre 2.10

To use the project quota functionality introduced in Lustre 2.10, **all Lustre servers and clients must be upgraded to Lustre release 2.10 or later for project quota to work correctly**. Otherwise, project quota will be inaccessible on clients and not be accounted for on OSTs. Furthermore, the **servers may be required to use a patched kernel**, for more information see Section 25.2, “Enabling Disk Quotas”.

Introduced in Lustre 2.14

`df` and `lfs df` will return the amount of space available to that project rather than the total filesystem space, if the project quota limit is smaller. **Only client need be upgraded to Lustre release 2.14 or later to apply this new behavior**.

25.7. Granted Cache and Quota Limits

In a Lustre file system, granted cache does not respect quota limits. In this situation, OSTs grant cache to a Lustre client to accelerate I/O. Granting cache causes writes to be successful in OSTs, even if they exceed the quota limits, and will overwrite them.

The sequence is:

1. A user writes files to the Lustre file system.
2. If the Lustre client has enough granted cache, then it returns 'success' to users and arranges the writes to the OSTs.
3. Because Lustre clients have delivered success to users, the OSTs cannot fail these writes.

Because of granted cache, writes always overwrite quota limitations. For example, if you set a 400 GB quota on user A and use IOR to write for user A from a bundle of clients, you will write much more data than 400 GB, and cause an out-of-quota error (`EDQUOT`).

Note

The effect of granted cache on quota limits can be mitigated, but not eradicated. Reduce the maximum amount of dirty data on the clients (minimal value is 1MB):

- `lctl set_param osc.*.max_dirty_mb=8`

25.8. Lustre Quota Statistics

The Lustre software includes statistics that monitor quota activity, such as the kinds of quota RPCs sent during a specific period, the average time to complete the RPCs, etc. These statistics are useful to measure performance of a Lustre file system.

Each quota statistic consists of a quota event and `min_time`, `max_time` and `sum_time` values for the event.

Quota Event	Description
<code>sync_acq_req</code>	Quota slaves send a <code>acquiring_quota</code> request and wait for its return.
<code>sync_rel_req</code>	Quota slaves send a <code>releasing_quota</code> request and wait for its return.
<code>async_acq_req</code>	Quota slaves send an <code>acquiring_quota</code> request and do not wait for its return.
<code>async_rel_req</code>	Quota slaves send a <code>releasing_quota</code> request and do not wait for its return.
<code>wait_for_blk_quota (lquota_chkquota)</code>	Before data is written to OSTs, the OSTs check if the remaining block quota is sufficient. This is done in the <code>lquota_chkquota</code> function.
<code>wait_for_ino_quota (lquota_chkquota)</code>	Before files are created on the MDS, the MDS checks if the remaining inode quota is sufficient. This is done in the <code>lquota_chkquota</code> function.
<code>wait_for_blk_quota (lquota_pending_commit)</code>	After blocks are written to OSTs, relative quota information is updated. This is done in the <code>lquota_pending_commit</code> function.
<code>wait_for_ino_quota (lquota_pending_commit)</code>	After files are created, relative quota information is updated. This is done in the <code>lquota_pending_commit</code> function.
<code>wait_for_pending_blk_quota_req (qtxt_wait_pending_dqacq)</code>	On the MDS or OSTs, there is one thread sending a quota request for a specific UID/GID for block quota at any time. At that time, if other threads need to do this too, they should wait. This is done in the <code>qtxt_wait_pending_dqacq</code> function.
<code>wait_for_pending_ino_quota_req (qtxt_wait_pending_dqacq)</code>	On the MDS, there is one thread sending a quota request for a specific UID/GID for inode quota at any time. If other threads need to do this too, they should wait. This is done in the <code>qtxt_wait_pending_dqacq</code> function.
<code>nowait_for_pending_blk_quota_req (qtxt_wait_pending_dqacq)</code>	On the MDS or OSTs, there is one thread sending a quota request for a specific UID/GID

Quota Event	Description
	for block quota at any time. When threads enter <code>qctxt_wait_pending_dqacq</code> , they do not need to wait. This is done in the <code>qctxt_wait_pending_dqacq</code> function.
<code>nowait_for_pending_ino_quota_req</code> (<code>qctxt_wait_pending_dqacq</code>)	On the MDS, there is one thread sending a quota request for a specific UID/GID for inode quota at any time. When threads enter <code>qctxt_wait_pending_dqacq</code> , they do not need to wait. This is done in the <code>qctxt_wait_pending_dqacq</code> function.
<code>quota_ctl</code>	The <code>quota_ctl</code> statistic is generated when <code>lfs setquota</code> , <code>lfs quota</code> and so on, are issued.
<code>adjust_qunit</code>	Each time <code>qunit</code> is adjusted, it is counted.

25.8.1. Interpreting Quota Statistics

Quota statistics are an important measure of the performance of a Lustre file system. Interpreting these statistics correctly can help you diagnose problems with quotas, and may indicate adjustments to improve system performance.

For example, if you run this command on the OSTs:

```
lctl get_param lquota.testfs-OST0000.stats
```

You will get a result similar to this:

```
snapshot_time                1219908615.506895 secs.usecs
async_acq_req                 1 samples [us]  32 32 32
async_rel_req                 1 samples [us]   5 5 5
nowait_for_pending_blk_quota_req(qctxt_wait_pending_dqacq) 1 samples [us] 2\
 2 2
quota_ctl                     4 samples [us]  80 3470 4293
adjust_qunit                  1 samples [us]  70 70 70
....
```

In the first line, `snapshot_time` indicates when the statistics were taken. The remaining lines list the quota events and their associated data.

In the second line, the `async_acq_req` event occurs one time. The `min_time`, `max_time` and `sum_time` statistics for this event are 32, 32 and 32, respectively. The unit is microseconds (μ s).

In the fifth line, the `quota_ctl` event occurs four times. The `min_time`, `max_time` and `sum_time` statistics for this event are 80, 3470 and 4293, respectively. The unit is microseconds (μ s).

Introduced in Lustre 2.14

25.9. Pool Quotas

OST Pool Quotas feature gives an ability to limit user's (group's/project's) disk usage at OST pool level. Each OST Pool Quota (PQ) maps directly to the OST pool of the same name. Thus PQ could be tuned

with standard `lctl pool_new/add/remove/erase` commands. All PQ are subset of a global pool that includes all OSTs and MDTs (DOM case). It may be initially confusing to be prevented from using "all of" one quota due to a different quota setting. In Lustre, a quota is a limit, not a right to use an amount. You don't always get to use your quota - an OST may be out of space, or some other quota is limiting. For example, if there is an inode quota and a space quota, and you hit your inode limit while you still have plenty of space, you can't use the space. For another example, quotas may easily be over-allocated: everyone gets 10PB of quota, in a 15PB system. That does not give them the right to use 10PB, it means they cannot use more than 10PB. They may very well get ENOSPC long before that - but they will not get EDQUOT. This behavior already exists in Lustre today, but pool quotas increase the number of limits in play: user, group or project global space quota and now all of those limits can also be defined for each pool. In all cases, the net effect is that the actual amount of space you can use is limited to the smallest (min) quota out of everything that is applicable. See more details in `OST Pool Quotas HLD` [http://wiki.lustre.org/OST_Pool_Quotas_HLD]

25.9.1. DOM and MDT pools

From Quota Master point of view, "data" MDTs are regular members together with OSTs. However Pool Quotas support only OSTs as there is currently no mechanism to group MDTs in pools.

25.9.2. Lfs quota/setquota options to setup quota pools

The same long option `--pool` is used to setup and report Pool Quotas with `lfs setquota` and `lfs setquota`.

`lfs setquota --pool pool_name` is used to set the block and soft usage limit for the user, group, or project for the specified pool name.

`lfs quota --pool pool_name` shows the user, group, or project usage for the specified pool name.

25.9.3. Quota pools interoperability

Both client and server should have at least Lustre 2.14 to support Pool Quotas.

Note

Pool Quotas may be able to work with older clients if server supports Pool Quotas. Pool quotas cannot be viewed or modified by older clients. Since the quota enforcement is done on the servers, only a single client is needed to configure the quotas. This could be done by mounting a client directly on the MDS if needed.

25.9.4. Pool Quotas Hard Limit setup example

Let's imagine you need to setup quota usage for already existed OST pool `flash_pool`:

```
# it is a limit for global pool. PQ don't work properly without that
lfs setquota -u ivan -B100T /mnt/testfs
# set 1TiB block hard limit for ivan in a flash_pool
lfs setquota -u ivan --pool flash_pool -B1T /mnt/testfs
```

Note

System-side hard limit is required before setting Quota Pool limit. If you do not need to limit user at all OSTs and MDTs at system, only per pool, it is recommended to set some unrealistic big hard limit. Without a global limit in place the Quota Pool limit will not be enforced. No matter hard or soft global limit - at least one of them should be set.

25.9.5. Pool Quotas Soft Limit setup example

```
# notify OSTs to enforce quota for ivan
lfs setquota -u ivan -B10T /mnt/testfs
# soft limit 10MiB for ivan in a pool flash_pool
lfs setquota -u ivan --pool flash_pool -b1T /mnt/testfs
# set block grace 600 s for all users at flash_pool
lfs setquota -t -u --block-grace 600 --pool flash_pool /mnt/testfs
```

Chapter 26. Hierarchical Storage Management (HSM)

This chapter describes how to bind Lustre to a Hierarchical Storage Management (HSM) solution.

26.1. Introduction

The Lustre file system can bind to a Hierarchical Storage Management (HSM) solution using a specific set of functions. These functions enable connecting a Lustre file system to one or more external storage systems, typically HSMs. With a Lustre file system bound to a HSM solution, the Lustre file system acts as a high speed cache in front of these slower HSM storage systems.

The Lustre file system integration with HSM provides a mechanism for files to simultaneously exist in a HSM solution and have a metadata entry in the Lustre file system that can be examined. Reading, writing or truncating the file will trigger the file data to be fetched from the HSM storage back into the Lustre file system.

The process of copying a file into the HSM storage is known as *archive*. Once the archive is complete, the Lustre file data can be deleted (known as *release*.) The process of returning data from the HSM storage to the Lustre file system is called *restore*. The archive and restore operations require a Lustre file system component called an *Agent*.

An Agent is a specially designed Lustre client node that mounts the Lustre file system in question. On an Agent, a user space program called a copytool is run to coordinate the archive and restore of files between the Lustre file system and the HSM solution.

Requests to restore a given file are registered and dispatched by a facet on the MDT called the Coordinator.

Figure 26.1. Overview of the Lustre file system HSM

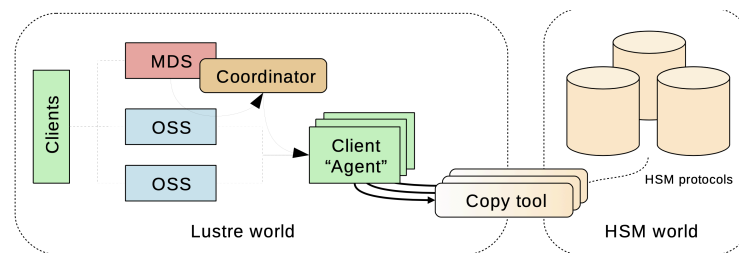

26.2. Setup

26.2.1. Requirements

To setup a Lustre/HSM configuration you need:

- a standard Lustre file system (version 2.5.0 and above)

- a minimum of 2 clients, 1 used for your chosen computation task that generates useful data, and 1 used as an agent.

Multiple agents can be employed. All the agents need to share access to their backend storage. For the POSIX copytool, a POSIX namespace like NFS or another Lustre file system is suitable.

26.2.2. Coordinator

To bind a Lustre file system to a HSM system a coordinator must be activated on each of your filesystem MDTs. This can be achieved with the command:

```
$ lctl set_param mdt.$FSNAME-MDT0000.hsm_control=enabled  
mdt.lustre-MDT0000.hsm_control=enabled
```

To verify that the coordinator is running correctly

```
$ lctl get_param mdt.$FSNAME-MDT0000.hsm_control  
mdt.lustre-MDT0000.hsm_control=enabled
```

26.2.3. Agents

Once a coordinator is started, launch the copytool on each agent node to connect to your HSM storage. If your HSM storage has POSIX access this command will be of the form:

```
lhmtool_posix --daemon --hsm-root $HSM_PATH --archive=1 $LUSTRE_PATH
```

The POSIX copytool must be stopped by sending it a TERM signal.

26.3. Agents and copytool

Agents are Lustre file system clients running copytool. copytool is a userspace daemon that transfers data between Lustre and a HSM solution. Because different HSM solutions use different APIs, copytools can typically only work with a specific HSM. Only one copytool can be run by an agent node.

The following rule applies regarding copytool instances: a Lustre file system only supports a single copytool process, per ARCHIVE ID (see below), per client node. Due to a Lustre software limitation, this constraint is irrespective of the number of Lustre file systems mounted by the Agent.

Bundled with Lustre tools, the POSIX copytool can work with any HSM or external storage that exports a POSIX API.

26.3.1. Archive ID, multiple backends

A Lustre file system can be bound to several different HSM solutions. Each bound HSM solution is identified by a number referred to as ARCHIVE ID. A unique value of ARCHIVE ID must be chosen for each bound HSM solution. ARCHIVE ID must be in the range 1 to 32.

A Lustre file system supports an unlimited number of copytool instances. You need, at least, one copytool per ARCHIVE ID. When using the POSIX copytool, this ID is defined using --archive switch.

For example: if a single Lustre file system is bound to 2 different HSMs (A and B,) ARCHIVE ID “1” can be chosen for HSM A and ARCHIVE ID “2” for HSM B. If you start 3 copytool instances for ARCHIVE ID 1, all of them will use Archive ID “1”. The same rule applies for copytool instances dealing with the HSM B, using Archive ID “2”.

When issuing HSM requests, you can use the `--archive` switch to choose the backend you want to use. In this example, file `foo` will be archived into backend ARCHIVE ID “5”:

```
$ lfs hsm_archive --archive=5 /mnt/lustre/foo
```

A default ARCHIVE ID can be defined which will be used when the `--archive` switch is not specified:

```
$ lctl set_param -P mdt.lustre-MDT0000.hsm.default_archive_id=5
```

The ARCHIVE ID of archived files can be checked using `lfs hsm_state` command:

```
$ lfs hsm_state /mnt/lustre/foo  
/mnt/lustre/foo: (0x00000009) exists archived, archive_id:5
```

26.3.2. Registered agents

A Lustre file system allocates a unique UUID per client mount point, for each filesystem. Only one copytool can be registered for each Lustre mount point. As a consequence, the UUID uniquely identifies a copytool, per filesystem.

The currently registered copytool instances (agents UUID) can be retrieved by running the following command, per MDT, on MDS nodes:

```
$ lctl get_param -n mdt.$FSNAME-MDT0000.hsm.agents  
uuid=a19b2416-0930-fc1f-8c58-c985ba5127ad archive_id=1 requests=[current:0
```

The returned fields have the following meaning:

- `uuid` the client mount used by the corresponding copytool.
- `archive_id` comma-separated list of ARCHIVE IDs accessible by this copytool.
- `requests` various statistics on the number of requests processed by this copytool.

26.3.3. Timeout

One or more copytool instances may experience conditions that cause them to become unresponsive. To avoid blocking access to the related files a timeout value is defined for request processing. A copytool must be able to fully complete a request within this time. The default is 3600 seconds.

```
$ lctl set_param -n mdt.lustre-MDT0000.hsm.active_request_timeout
```

26.4. Requests

Data management between a Lustre file system and HSM solutions is driven by requests. There are five types:

- ARCHIVE Copy data from a Lustre file system file into the HSM solution.

- **RELEASE** Remove file data from the Lustre file system.
- **RESTORE** Copy back data from the HSM solution into the corresponding Lustre file system file.
- **REMOVE** Delete the copy of the data from the HSM solution.
- **CANCEL** Cancel an in-progress or pending request.

Only the **RELEASE** is performed synchronously and does not involve the coordinator. Other requests are handled by Coordinators. Each MDT coordinator is resiliently managing them.

26.4.1. Commands

Requests are submitted using `lfs` command:

```
$ lfs hsm_archive [--archive=ID] FILE1 [FILE2...]  
$ lfs hsm_release FILE1 [FILE2...]  
$ lfs hsm_restore FILE1 [FILE2...]  
$ lfs hsm_remove FILE1 [FILE2...]
```

Requests are sent to the default ARCHIVE ID unless an ARCHIVE ID is specified with the `--archive` option (See Section 26.3.1, “Archive ID, multiple backends”).

26.4.2. Automatic restore

Released files are automatically restored when a process tries to read or modify them. The corresponding I/O will block waiting for the file to be restored. This is transparent to the process. For example, the following command automatically restores the file if released.

```
$ cat /mnt/lustre/released_file
```

26.4.3. Request monitoring

The list of registered requests and their status can be monitored, per MDT, with the following command:

```
$ lctl get_param -n mdt.lustre-MDT0000.hsm.actions
```

The list of requests currently being processed by a copytool is available with:

```
$ lctl get_param -n mdt.lustre-MDT0000.hsm.active_requests
```

26.5. File states

When files are archived or released, their state in the Lustre file system changes. This state can be read using the following `lfs` command:

```
$ lfs hsm_state FILE1 [FILE2...]
```

There is also a list of specific policy flags which could be set to have a per-file specific policy:

- **NOARCHIVE** This file will never be archived.

- **NORELEASE** This file will never be released. This value cannot be set if the flag is currently set to **RELEASED**
- **DIRTY** This file has been modified since a copy of it was made in the HSM solution. **DIRTY** files should be archived again. The **DIRTY** flag can only be set if **EXIST** is set.

The following options can only be set by the root user.

- **LOST** This file was previously archived but the copy was lost on the HSM solution for some reason in the backend (for example, by a corrupted tape), and could not be restored. If the file is not in the **RELEASE** state it needs to be archived again. If the file is in the **RELEASE** state, the file data is lost.

Some flags can be manually set or cleared using the following commands:

```
$ lfs hsm_set [FLAGS] FILE1 [FILE2...]  
$ lfs hsm_clear [FLAGS] FILE1 [FILE2...]
```

26.6. Tuning

26.6.1. hsm_controlpolicy

`hsm_control` controls coordinator activity and can also purge the action list.

```
$ lctl set_param mdt.$FSNAME-MDT0000.hsm_control=purge
```

Possible values are:

- **enabled** Start coordinator thread. Requests are dispatched on available copytool instances.
- **disabled** Pause coordinator activity. No new request will be scheduled. No timeout will be handled. New requests will be registered but will be handled only when the coordinator is enabled again.
- **shutdown** Stop coordinator thread. No request can be submitted.
- **purge** Clear all recorded requests. Do not change coordinator state.

26.6.2. max_requests

`max_requests` is the maximum number of active requests at the same time. This is a per coordinator value, and independent of the number of agents.

For example, if 2 MDT and 4 agents are present, the agents will never have to handle more than $2 \times \text{max_requests}$.

```
$ lctl set_param mdt.$FSNAME-MDT0000.hsm.max_requests=10
```

26.6.3. policy

Change system behavior. Values can be added or removed by prefixing them with '+' or '-'.

```
$ lctl set_param mdt.$FSNAME-MDT0000.hsm.policy=+NRA
```

Possible values are a combination of:

- NRA No Retry Action. If a restore fails, do not reschedule it automatically.
- NBR Non Blocking Restore. Restore is triggered but does not block clients. Access to a released file returns ENODATA.

26.6.4. `grace_delay`

`grace_delay` is the delay, expressed in seconds, before a successful or failed request is cleared from the whole request list.

```
$ lctl set_param mdt.$FSNAME-MDT0000.hsm.grace_delay=10
```

26.7. change logs

A changelog record type “HSM” was added for Lustre file system logs that relate to HSM events.

```
16HSM 13:49:47.469433938 2013.10.01 0x280 t=[0x200000400:0x1:0x0]
```

Two items of information are available for each HSM record: the FID of the modified file and a bit mask. The bit mask codes the following information (lowest bits first):

- Error code, if any (7 bits)
- HSM event (3 bits)
 - `HE_ARCHIVE` = 0 File has been archived.
 - `HE_RESTORE` = 1 File has been restored.
 - `HE_CANCEL` = 2 A request for this file has been canceled.
 - `HE_RELEASE` = 3 File has been released.
 - `HE_REMOVE` = 4 A remove request has been executed automatically.
 - `HE_STATE` = 5 File flags have changed.
- HSM flags (3 bits)
 - `CLF_HSM_DIRTY=0x1`

In the above example, `0x280` means the error code is 0 and the event is `HE_STATE`.

When using `liblustreapi`, there is a list of helper functions to easily extract the different values from this bitmask, like: `hsm_get_cl_event()`, `hsm_get_cl_flags()`, and `hsm_get_cl_error()`

26.8. Policy engine

A Lustre file system does not have an internal component responsible for automatically scheduling archive requests and release requests under any conditions (like low space). Automatically scheduling archive operations is the role of the policy engine.

It is recommended that the Policy Engine run on a dedicated client, similar to an agent node, with a Lustre version 2.5+.

A policy engine is a userspace program using the Lustre file system HSM specific API to monitor the file system and schedule requests.

Robinhood is the recommended policy engine.

26.8.1. Robinhood

Robinhood is a Policy engine and reporting tool for large file systems. It maintains a replicate of file system metadata in a database that can be queried at will. Robinhood makes it possible to schedule mass action on file system entries by defining attribute-based policies, provides fast `find` and `du` enhanced clones, and provides administrators with an overall view of file system content through a web interface and command line tools.

Robinhood can be used for various configurations. Robinhood is an external project, and further information can be found on the project website: <https://sourceforge.net/apps/trac/robinhood/wiki/Doc>.

Chapter 27. Persistent Client Cache (PCC)

This chapter describes Persistent Client Cache (PCC).

27.1. Introduction

Flash-based SSDs help to (partly) close the ever-increasing performance gap between magnetic disks and CPUs. SSDs build a new level in the storage hierarchy, both in terms of price and performance. The large size of data sets stored in Lustre, ranging up to hundreds of PiB in the largest centers, makes it more cost-effective to store most of the data on HDDs and only an active subset of data on SSDs.

The PCC mechanism allows clients equipped with internal SSDs to deliver additional performance for both read and write intensive applications that have node-local I/O patterns without losing the benefits of the global Lustre namespace. PCC is combined with Lustre HSM and layout lock mechanisms to provide persistent caching services using the local SSD storage, while allowing migration of individual files between local and shared storage. This enables I/O intensive applications to read and write data on client nodes without losing the benefits of the global Lustre namespace.

The main advantages to use this cache on the Lustre clients is that the I/O stack is much simpler for the cached data, as there is no interference with I/Os from other clients, which enables performance optimizations. There are no special requirements on the hardware of the client nodes. Any Linux filesystem, such as ext4 on an NVMe device, can be used as PCC cache. Local file caching reduces the pressure on the object storage targets (OSTs), as small or random I/Os can be aggregated to large sequential I/Os and temporary files do not even need to be flushed to OSTs.

27.2. Design

27.2.1. Lustre Read-Write PCC Caching

Figure 27.1. Overview of PCC-RW Architecture

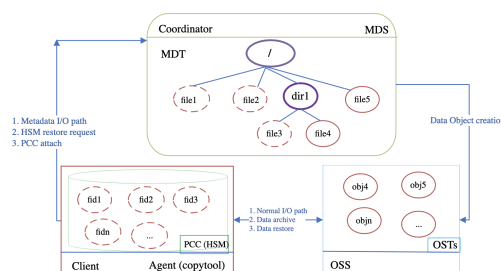

Lustre typically uses its integrated HSM mechanism to interface with larger and slower archival storage using tapes or other media. PCC-RW, on the contrary, is actually an HSM

backend storage system which provides a group of high-speed local caches on Lustre clients. Figure 27.1, “Overview of PCC-RW Architecture” shows the PCC-RW architecture. Each client uses its own local storage, usually in the form of NVMe, formatted as a local file system for the local cache. Cached I/Os are directed to files in the local file system, while normal I/O are directed to OSTs.

PCC-RW uses Lustre's HSM mechanism for data synchronization. Each PCC node is actually an HSM agent and has a copy tool instance running on it. The Lustre HSM copytool is used to restore files from the local cache to Lustre OSTs. Any remote access for a PCC cached file from another Lustre client triggers this data synchronization. If a PCC client goes offline, the cached data becomes temporarily inaccessible to other clients. The data will be accessible again after the PCC client reboots, mounts the Lustre filesystem, and restarts the copytool.

Currently, PCC clients cache entire files on their local filesystems. A file has to be attached to PCC before I/O can be directed to a client cache. The Lustre layout lock feature is used to ensure that the caching services are consistent with the global file system state. The file data can be written/read directly to/from the local PCC cache after a successful attach operation. If the attach has not been successful, the client will simply fall back to the normal I/O path and direct I/Os to OSTs. PCC-RW cached files are automatically restored to the global filesystem when a process on another client tries to read or modify them. The corresponding I/O will be blocked, waiting for the released file to be restored. This is transparent to the application.

The revocation of the layout lock can automatically detach the file from the PCC cache at any time. The PCC-RW cached file can be manually detached by the `lfs pcc detach` command. After the cached file is detached from the cache and restored to OSTs, it will be removed from the PCC filesystem.

Failed PCC-RW operations usually return corresponding error codes. There is a special case when the space of the local PCC file system is exhausted. In this case, PCC-RW can fall back to the normal I/O path automatically since the capacity of the Lustre file system is much larger than the capacity of the PCC device.

27.2.2. Rule-based Persistent Client Cache

PCC includes a rule-based, configurable caching infrastructure that enables it to achieve various objectives, such as customizing I/O caching and providing performance isolation and QoS guarantees.

For PCC-RW, when a file is being created, a rule-based policy is used to determine whether it will be cached. It supports rules for different users, groups, projects, or filenames extensions.

Rule-based PCC-RW caching of newly created files can determine which file can use a cache on PCC directly without administrator's intervention.

27.3. PCC Command Line Tools

Lustre provides `lfs` and `lctl` command line tools for users to interact with PCC feature.

27.3.1. Add a PCC backend on a client

Command:

```
client# lctl pcc add mountpoint pccpath [--param|-p cfgparam]
```

The above command will add a PCC backend to the Lustre client.

Option	Description
mountpoint	The Lustre client mount point.
pccpath	The directory path on local filesystem for PCC cache. The whole filesystem does not need to be exclusively dedicated to the PCC cache, but the directory should not be accessible to regular users.
cfgparam	A string in the form of name-value pairs to config the PCC backend such as read-write attach id (archive ID), and auto caching rule, etc.

Note: when a client node has more than one Lustre mount point or Lustre filesystem instance, the parameter *mountpoint* makes sure that only the PCC backend on specified Lustre filesystem instance or Lustre mount point is configured. This Lustre mount point must be the same as the HSM (*lhsmttool_posix*) configuration, if the PCC backend is used as PCC-RW caching. Also, the parameter *pccpath* should be the same as the HSM root parameter of the POSIX copytool (*lhsmttool_posix*).

PCC-RW uses Lustre's HSM mechanism for data synchronization. Before using PCC-RW on a client, it is still necessary to setup HSM on the MDTs and the PCC client nodes.

First, a coordinator must be activated on each of the filesystem MDTs. This can be achieved with the command:

```
mds# lctl set_param mdt.$FSNAME-MDT0000.hsm_control=enabled
mdt.lustre-MDT0000.hsm_control=enabled
```

Next, launch the copytool on each agent node (PCC client node) to connect to your HSM storage. This command will be of the form:

```
client# lhsmttool_posix --daemon --hsm-root $PCCPATH --archive=$ARCHIVE_ID
```

Examples:

The following command adds a PCC backend on a client:

```
client# lctl pcc add /mnt/lustre /mnt/pcc --param "projid={500,1000}&fnam
```

The first substring of the config parameter is the auto-cache rule, where "&" represents the logical AND operator while "," represents the logical OR operator. The example rule means that new files are only auto cached if either of the following conditions are satisfied:

- The project ID is either 500 or 1000 and the suffix of the file name is "h5";
- The user ID is 1001;

The currently supported name-value pairs for PCC backend configuration are listing as follows:

- *rwid* PCC-RW attach ID which is same as the archive ID of the copytool agent running on this PCC node.
- *auto_attach* "auto_attach=1" enables auto attach at the next open or during I/O. Enabling this option should cause automatic attaching of valid PCC-cached files which

were detached due to the manual `lfs pcc detach` command or revocation of layout lock (i.e. LRU lock shrinking). `"auto_attach=0"` means that auto file attach is disabled and is the default mode.

27.3.2. Delete a PCC backend from a client

Command:

```
lctl pcc del <mountpoint> <pccpath>
```

The above command will delete a PCC backend from a Lustre client.

Option	Description
mountpoint	The Lustre client mount point.
pccpath	A PCC backend is specified by this path. Please refer to <code>lctl pcc add</code> for details.

Examples:

The following command will delete a PCC backend referenced by `"/mnt/pcc"` on a client with the mount point of `"/mnt/lustre"`.

```
client# lctl pcc del /mnt/lustre /mnt/pcc
```

27.3.3. Remove all PCC backends on a client

Command:

```
lctl pcc clear <mountpoint>
```

The above command will remove all PCC backends on a Lustre client.

Option	Description
mountpoint	The Lustre client mount point.

Examples:

The following command will remove all PCC backends from a client with the mount point of `"/mnt/lustre"`.

```
client# lctl pcc clear /mnt/lustre
```

27.3.4. List all PCC backends on a client

Command:

```
lctl pcc list <mountpoint>
```

The above command will list all PCC backends on a Lustre client.

Option	Description
mountpoint	The Lustre client mount point.

Examples:

The following command will list all PCC backends on a client with the mount point of `"/mnt/lustre"`.

```
client# lctl pcc list /mnt/lustre
```

27.3.5. Attach given files into PCC

Command:

```
lfs pcc attach --id|-i <NUM> <file...>
```

The above command will attach the given files onto PCC.

Option	Description
<code>--id -i <NUM></code>	Attach ID to select which PCC backend to use.

Examples:

The following command will attach the file referenced by `/mnt/lustre/test` onto the PCC backend with PCC-RW attach ID that equals 2.

```
client# lfs pcc attach -i 2 /mnt/lustre/test
```

27.3.6. Attach given files into PCC by FID(s)

Command:

```
lfs pcc attach_fid --id|-i <NUM> --mnt|-m <mountpoint> <fid...>
```

The above command will attach the given files referenced by their FIDs into PCC.

Option	Description
<code>--id -i <NUM></code>	Attach ID to select which PCC backend to use.
<code>--mnt -m <mountpoint></code>	The Lustre mount point.

Examples:

The following command will attach the file referenced by FID `0x200000401:0x1:0x0` onto the PCC backend with PCC-RW attach ID that equals 2.

```
client# lfs pcc attach_fid -i 2 -m /mnt/lustre 0x200000401:0x1:0x0
```

27.3.7. Detach given files from PCC

Command:

```
lfs pcc detach [--keep|-k] <file...>
```

The above command will detach given files from PCC.

Option	Description
<code>--keep -k</code>	By default, the <code>detach</code> command will detach the file from PCC permanently and remove the PCC copy after detach.

Option	Description
	This option will only detach the file, but keep the PCC copy in cache. It allows the detached file to be attached automatically at the next open if the cached copy of the file is still valid.

Examples:

The following command will detach the file referenced by `/mnt/lustre/test` from PCC permanently and remove the corresponding cached file on PCC.

```
client# lfs pcc detach /mnt/lustre/test
```

The following command will detach the file referenced by `/mnt/lustre/test` from PCC, but allow the file to be attached automatically at the next open.

```
client# lfs pcc detach -k /mnt/lustre/test
```

27.3.8. Detach given files from PCC by FID(s)

Command:

```
lfs pcc detach_fid [--keep|-k] <mountpoint> <fid...>
```

The above command will detach the given files from PCC by FID(s).

Option	Description
<code>--keep -k</code>	Please refer to the command <code>lfs pcc detach</code> for details

Examples:

The following command will detach the file referenced by FID `0x200000401:0x1:0x0` from PCC permanently and remove the corresponding cached file on PCC.

```
client# lfs pcc detach_fid /mnt/lustre 0x200000401:0x1:0x0
```

The following command will detach the file referenced by FID `0x200000401:0x1:0x0` from PCC, but allow the file to be attached automatically at the next open.

```
client# lfs pcc detach_fid -k /mnt/lustre 0x200000401:0x1:0x0
```

27.3.9. Display the PCC state for given files

Command:

```
lfs pcc state <file...>
```

The above command will display the PCC state for given files.

Examples:

The following command will display the PCC state of the file referenced by `/mnt/lustre/test`.

```
client# lfs pcc state /mnt/lustre/test
file: /mnt/lustre/test, type: readwrite, PCC file: /mnt/pcc/0004/0000/0bd1
```

If the file "/mnt/lustre/test" is not cached on PCC, the output of its PCC state is as follow:

```
client# lfs pcc state /mnt/lustre/test
file: /mnt/lustre/test, type: none
```

27.4. PCC Configuration Example

1. Setup HSM on MDT

```
mds# lctl set_param mdt.lustre-MDT0000.hsm_control=enabled
```

2. Setup PCC on the clients

```
client1# lsmtool_posix --daemon --hsm-root /mnt/pcc --archive=1 /mnt/lu
client1# lctl pcc add /mnt/lustre /mnt/pcc "projid={1000},uid={500} rwid
```

```
client2# lsmtool_posix --daemon --hsm-root /mnt/pcc --archive=2 /mnt/lu
client2# lctl pcc add /mnt/lustre /mnt/pcc "projid={1000}&gid={500} rwid
```

3. Execute PCC commands on the clients

```
client1# echo "QQQQQ" > /mnt/lustre/test
```

```
client2# lfs pcc attach -i 2 /mnt/lustre/test
```

```
client2# lfs pcc state /mnt/lustre/test
file: /mnt/lustre/test, type: readwrite, PCC file: /mnt/pcc/0004/0000/0b
```

```
client2# lfs pcc detach /mnt/lustre/test
```

Chapter 28. Mapping UIDs and GIDs with Nodemap

This chapter describes how to map UID and GIDs across a Lustre file system using the nodemap feature, and includes the following sections:

- Section 28.1, “Setting a Mapping”
- Section 28.2, “Removing Nodemaps”
- Section 28.3, “Altering Properties”
- Section 28.4, “Enabling the Feature”
- Section 28.5, “default Nodemap”
- Section 28.6, “Verifying Settings”
- Section 28.7, “Ensuring Consistency”

28.1. Setting a Mapping

The nodemap feature allows UIDs and GIDs from remote systems to be mapped to local sets of UIDs and GIDs while retaining POSIX ownership, permissions and quota information. As a result, multiple sites with conflicting user and group identifiers can operate on a single Lustre file system without creating collisions in UID or GID space.

28.1.1. Defining Terms

When the nodemap feature is enabled, client file system access to a Lustre system is filtered through the nodemap identity mapping policy engine. Lustre connectivity is governed by network identifiers, or *NIDs*, such as `192.168.7.121@tcp`. When an operation is made from a NID, Lustre decides if that NID is part of a *nodemap*, a policy group consisting of one or more NID ranges. If no policy group exists for that NID, access is squashed to user `nobody` by default. Each policy group also has several *properties*, such as `trusted` and `admin`, which determine access conditions. A collection of identity maps or *idmaps* are kept for each policy group. These *idmaps* determine how UIDs and GIDs on the client are translated into the canonical user space of the local Lustre file system.

In order for nodemap to function properly, the MGS, MDS, and OSS systems must all have a version of Lustre which supports nodemap. Clients operate transparently and do not require special configuration or knowledge of the nodemap setup.

28.1.2. Deciding on NID Ranges

NIDs can be described as either a singleton address or a range of addresses. A single address is described in standard Lustre NID format, such as `10.10.6.120@tcp`. A range is described using a dash to separate the range, for example, `192.168.20.[0-255]@tcp`.

The range must be contiguous. The full LNet definition for a nidlist is as follows:

```

<nidlist>      ::= <nidrange> [ ' ' <nidrange> ]
<nidrange>     ::= <addrrange> '@' <net>
<addrrange>   ::= '*' |
                  <ipaddr_range> |
                  <numaddr_range>
<ipaddr_range> ::=
    <numaddr_range>.<numaddr_range>.<numaddr_range>.<numaddr_range>
<numaddr_range> ::= <number> |
                  <expr_list>
<expr_list>   ::= '[' <range_expr> [ ',' <range_expr> ] "'"
<range_expr>  ::= <number> |
                  <number> '-' <number> |
                  <number> '-' <number> '/' <number>
<net>         ::= <netname> | <netname><number>
<netname>     ::= "lo" | "tcp" | "o2ib" | "gni"
<number>     ::= <nonnegative decimal> | <hexadecimal>

```

28.1.3. Defining a Servers Specific Group

For proper operations, the Lustre file system **requires** to have a privileged group that covers all Lustre server nodes. So the very first step when working with nodemaps is to create such a group with both properties `admin` and `trusted` set. It is recommended to give this group an explicit label such as “TrustedSystems” or some identifier that makes the association clear.

Let's consider a deployment where the server nodes are in the NID range `192.168.0.[1-10]`@tcp. Create the policy group, add the NID range to that group, and set the properties accordingly using the `lctl` command on the MGS:

```

mgs# lctl nodemap_add TrustedSystems
mgs# lctl nodemap_add_range --name TrustedSystems --range 192.168.0.[1-10]
mgs# lctl nodemap_modify --name TrustedSystems --property admin --value 1
mgs# lctl nodemap_modify --name TrustedSystems --property trusted --value

```

28.1.4. Describing and Deploying a Sample Mapping

Deploy nodemap by first considering which users need to be mapped, and what sets of network addresses or ranges are involved. Issues of visibility between users must be examined as well.

Consider a deployment where researchers are working on data relating to birds. The researchers use a computing system which mounts the filesystem from a single IPv4 address, `192.168.0.100`, and sensors which mount the filesystem from an address range `192.168.0.[50-99]`. Name this policy group `BirdResearchSite`. Create the policy group and add the NID ranges to that group on the MGS using the `lctl` command:

```

mgs# lctl nodemap_add BirdResearchSite
mgs# lctl nodemap_add_range --name BirdResearchSite --range 192.16
mgs# lctl nodemap_add_range --name BirdResearchSite --range 192.16

```

Later, additional sensors were added that use addresses in the range 192.168.10.[101-150] that increased the number of nodes in the `BirdResearchSite` nodemap, but otherwise are managed as part of the same nodemap.

```
mgs# lctl nodemap_add_range --name BirdResearchSite --range 192.16
```

Note

A NID cannot be in more than one policy group. Assign a NID to a new policy group by first removing it from the existing group.

The researchers use the following identifiers on their host system:

- `swan` (UID 530) member of group `wetlands` (GID 600)
- `duck` (UID 531) member of group `wetlands` (GID 600)
- `hawk` (UID 532) member of group `raptor` (GID 601)
- `merlin` (UID 533) member of group `raptor` (GID 601)

Assign a set of six idmaps to this policy group, with four for UIDs, and two for GIDs. Pick a starting point, e.g. UID 11000, with room for additional UIDs and GIDs to be added as the configuration grows. Use the `lctl` command to set up the idmaps:

```
mgs# lctl nodemap_add_idmap --name BirdResearchSite --idtype uid --idmap 5
mgs# lctl nodemap_add_idmap --name BirdResearchSite --idtype uid --idmap 5
mgs# lctl nodemap_add_idmap --name BirdResearchSite --idtype uid --idmap 5
mgs# lctl nodemap_add_idmap --name BirdResearchSite --idtype uid --idmap 5
mgs# lctl nodemap_add_idmap --name BirdResearchSite --idtype gid --idmap 6
mgs# lctl nodemap_add_idmap --name BirdResearchSite --idtype gid --idmap 6
```

The parameter `530:11000` assigns a client UID, for example UID 530, to a single canonical UID, such as UID 11000. Each assignment is made individually. There is no method to specify a range `530-533:11000-11003`. UID and GID idmaps are assigned separately. There is no implied relationship between the two.

Files created on the Lustre file system from the `192.168.0.100@tcp` NID using UID `duck` and GID `wetlands` are stored in the Lustre file system using the canonical identifiers, in this case UID 11001 and GID 11000. A different NID, if not part of the same policy group, sees its own view of the same file space.

Suppose a previously created project directory exists owned by UID 11002/GID 11001, with mode 770. When users `hawk` and `merlin` at 192.168.0.100 place files named `hawk-file` and `merlin-file` into the directory, the contents from the 192.168.0.100 client appear as:

```
[merlin@192.168.0.100 projectsite]$ ls -la
total 34520
drwxrwx--- 2 hawk    raptor    4096 Jul 23 09:06 .
drwxr-xr-x 3 nobody  nobody    4096 Jul 23 09:02 ..
-rw-r--r-- 1 hawk    raptor 10240000 Jul 23 09:05 hawk-file
-rw-r--r-- 1 merlin  raptor 25100288 Jul 23 09:06 merlin-file
```

From a privileged view, the canonical owners are displayed:

```
[root@trustedSite projectsite]# ls -la
total 34520
drwxrwx--- 2 11002 11001      4096 Jul 23 09:06 .
drwxr-xr-x 3 root  root      4096 Jul 23 09:02 ..
-rw-r--r-- 1 11002 11001 10240000 Jul 23 09:05 hawk-file
-rw-r--r-- 1 11003 11001 25100288 Jul 23 09:06 merlin-file
```

If UID 11002 or GID 11001 do not exist on the Lustre MDS or MGS, create them in LDAP or other data sources, or trust clients by setting `identity_upcall` to `NONE`. For more information, see Section 41.1, “User/Group Upcall”.

Building a larger and more complex configuration is possible by iterating through the `lctl` commands above. In short:

1. Create a name for the policy group.
2. Create a set of NID ranges used by the group.
3. Define which UID and GID translations need to occur for the group.

Introduced in Lustre 2.15

28.1.5. Mapping Project IDs

Like UIDs and GIDs, PROJIDs can be mapped via nodemaps, from client to file system IDs and conversely. To declare a PROJID mapping, use the `projid` type:

```
mgs# lctl nodemap_add_idmap --name BirdResearchSite --idtype projid --idma
```

28.2. Removing Nodemaps

It is possible to delete a NID range from a nodemap, any clients in this NID range will be moved to the default nodemap.

```
mgs# lctl nodemap_del_range --name BirdResearchSite --range 192.168.0.[101
```

When deleting a range from a nodemap it must be the same range that was declared when using `nodemap_add_range`. This means that it is not possible to remove a range inside of the initial values or a (partially) overlapping range. Also worth noting, if two different ranges are added that are adjacent, they are still treated as two independent ranges and must be each individually deleted.

When deleting a whole policy group all of the associated ID mappings, NID ranges, and other parameters will be removed, and existing clients will be moved to the default nodemap. The default nodemap cannot be deleted. The syntax is:

```
mgs# lctl nodemap_del BirdResearchSite
```

28.3. Altering Properties

Privileged users access mapped systems with rights dependent on certain properties, described below. By default, root access is squashed to user `nobody`, which interferes with most administrative actions.

For proper operations, the Lustre file system **requires** a group that covers all Lustre server nodes, with both properties `admin` and `trusted` set. It is recommended to give this group an explicit label such as “TrustedSystems” or some identifier that makes the association clear.

28.3.1. Managing the Properties

Several properties exist, off by default, which change client behavior: `admin`, `trusted`, `map_mode`, `squash_uid`, `squash_gid`, `squash_projid`, `deny_unknown`, `audit_mode` and `forbid_encryption`.

- The property `admin` defines whether root is squashed on the policy group. By default, it is squashed, unless this property is enabled. Coupled with the `trusted` property, this will allow unmapped access for backup nodes, transfer points, or other administrative mount points.
- The `trusted` property permits members of a policy group to see the file system's canonical identifiers. In the above example, UID 11002 and GID 11001 will be seen without translation. This can be utilized when local UID and GID sets already map directly to the specified users.

Introduced in Lustre 2.10

The `map_mode` property lets control the way mapping is carried out. By default it is set to `all` which means the nodemap will map UIDs, GIDs, and PROJIDs. If set to `uid_only` or just `uid`, only UIDs will be mapped. If set to `gid_only` or just `gid`, only GIDs will be mapped. If set to `projid_only` or just `projid`, only PROJIDs will be mapped. If set to `both`, both UIDs and GIDs will be mapped. Multiple values can be specified, comma separated.

- The properties `squash_uid`, `squash_gid` and `squash_projid` define the default UID, GID and PROJID respectively that users will be squashed to if unmapped, unless the `deny_unknown` flag is set, in which case access will still be denied.

Note

The `squash_projid` property was introduced in Lustre 2.15

- The property `deny_unknown` denies all access to users not mapped in a particular nodemap. This is useful if a site is concerned about unmapped users accessing the file system in order to satisfy security requirements.

Introduced in Lustre 2.11

The property `audit_mode` lets control which Lustre client nodes can trigger the recording of file system access events to the Changelogs. When this flag is set to 1, clients will be able to record file system access events to the Changelogs, if Changelogs are otherwise activated. When set to 0, events are not logged into the Changelogs, no matter if Changelogs are activated or not. By default, this flag is set to 1 in newly created nodemap entries. And it is also set to 1 in 'default' nodemap.

Introduced in Lustre 2.14

The property `forbid_encryption` prevents clients from using encryption.

Introduced in Lustre 2.16

The property `readonly_mount` forces clients to a read-only mount if not specified explicitly. By default it is set to 0 which means clients are allowed to mount in read-write mode. Set it to 1 to force read-only mount.

Introduced in Lustre 2.16

The property `rbac` defines different Role-Based Admin Control mechanisms:

- `byfid_ops`, to allow operations by FID (e.g. 'lfs rmfid').
- `chlg_ops`, to allow access to Lustre Changelogs.
- `dne_ops`, to allow operations related to DNE (e.g. 'lfs mkdir').
- `file_perms`, to allow modifications of file permissions and owners.
- `fsencrypt_admin`, to allow fsencrypt related admin tasks (create or modify protectors/policies). Note that even without this role, it is still possible to lock or unlock encrypted directories, as these operations only need read access to fsencrypt metadata.
- `quota_ops`, to allow quota modifications.

The default value for this property is `all`, which means all roles are allowed. Multiple values among those listed above can be specified, comma separated. Apart from `all`, any role not explicitly specified is forbidden. And to forbid all roles, use `none` value.

Alter values to either true (1) or false (0) on the MGS:

```
mgs# lctl nodemap_modify --name BirdAdminSite --property trusted --value 1
mgs# lctl nodemap_modify --name BirdAdminSite --property admin --value 1
mgs# lctl nodemap_modify --name BirdAdminSite --property deny_unknown --va
```

Change values during system downtime to minimize the chance of any ownership or permissions problems if the policy group is active. Although changes can be made live, client caching of data may interfere with modification as there are a few seconds of lead time before the change is distributed.

28.3.2. Mixing Properties

With both `admin` and `trusted` properties set, the policy group has full access, as if `nodemap` was turned off, to the Lustre file system. The administrative site for the Lustre file system needs at least one group with both properties in order to perform maintenance or to perform administrative tasks.

Warning

Lustre server nodes **must** be in a policy group with both these properties set to 1. It is recommended to use a policy group labeled “TrustedSystems” or some identifier that makes the association clear.

If a policy group has the `admin` property set, but does not have the property `trusted` set, root is mapped directly to root, any explicitly specified UID and GID idmaps are honored, and other access is squashed. If root alters ownership to UIDs or GIDs which are locally known from that host but not part of an idmap, root effectively changes ownership of those files to the default squashed UID and GID.

If `trusted` is set but `admin` is not, the policy group has full access to the canonical UID and GID sets of the Lustre file system, and root is squashed.

The `deny_unknown` property, once enabled, prevents unmapped users from accessing the file system. Root access also is denied, if the `admin` property is off, and root is not part of any mapping.

Introduced in Lustre 2.15

To prevent a client from changing quota settings for a project other than the one assigned to the fileset it is restricted to, you should map the PROJID to itself, set `map_mode` to `projid`, and then `trusted` to 0 and `deny_unknown` to 1. This way, only operations on the designated PROJID will be allowed.

When nodemaps are modified, the change events are queued and distributed across the cluster. Under normal conditions, these changes can take around ten seconds to propagate. During this distribution window, file access could be made via the old or new nodemap settings. Therefore, it is recommended to save changes for a maintenance window or to deploy them while the mapped nodes are not actively writing to the file system.

28.4. Enabling the Feature

The nodemap feature is simple to enable:

```
mgs# lctl nodemap_activate 1
```

Passing the parameter 0 instead of 1 disables the feature again. After deploying the feature, validate the mappings are intact before offering the file system to be mounted by clients.

Introduced in Lustre 2.8

So far, changes have been made on the MGS. Prior to Lustre 2.9, changes must also be manually set on MDS systems as well. Also, changes must be manually deployed to OSS servers if quota is enforced, utilizing `lctl set_param` instead of `lctl`. Prior to 2.9, the configuration is not persistent, requiring a script which generates the mapping to be saved and deployed after every Lustre restart. As an example, use this style to deploy settings on the OSS:

```
oss# lctl set_param nodemap.add_nodemap=SiteName
oss# lctl set_param nodemap.add_nodemap_range='SiteName 192.168.0.15@tcp'
oss# lctl set_param nodemap.add_nodemap_idmap='SiteName uid 510:1700'
oss# lctl set_param nodemap.add_nodemap_idmap='SiteName gid 612:1702'
```

In Lustre 2.9 and later, nodemap configuration is saved on the MGS and distributed automatically to MGS, MDS, and OSS nodes, a process which takes approximately ten seconds in normal circumstances.

28.5. default Nodemap

There is a special nodemap called `default`. As the name suggests, it is created by default and cannot be removed. It is like a fallback nodemap, setting the behaviour for Lustre clients that do not match any other nodemap.

Because of its special role, only some parameters can be set on the `default` nodemap:

- `admin`

- `trusted`
- `squash_uid`
- `squash_gid`
- `fileset`
- `audit_mode`

In particular, no UID/GID mapping can be defined on the default `nodemap`.

Note

Be careful when altering the `admin` and `trusted` properties of the default `nodemap`, especially if your Lustre servers fall into this `nodemap`.

28.6. Verifying Settings

By using `lctl nodemap_info all`, existing `nodemap` configuration is listed for easy export. This command acts as a shortcut into the configuration interface for `nodemap`. On the Lustre MGS, the `nodemap.active` parameter contains a `1` if `nodemap` is active on the system. Each policy group creates a directory containing the following parameters:

- `admin` and `trusted` each contain a `1` if the values are set, and `0` otherwise.
- `idmap` contains a list of the `idmaps` for the policy group, while `ranges` contains a list of NIDs for the group.
- `squash_uid` and `squash_gid` determine what UID and GID users are squashed to if needed.

The expected outputs for the `BirdResearchSite` in the example above are:

```
mgs# lctl get_param nodemap.BirdResearchSite.idmap
```

```
[
  { idtype: uid, client_id: 530, fs_id: 11000 },
  { idtype: uid, client_id: 531, fs_id: 11001 },
  { idtype: uid, client_id: 532, fs_id: 11002 },
  { idtype: uid, client_id: 533, fs_id: 11003 },
  { idtype: gid, client_id: 600, fs_id: 11000 },
  { idtype: gid, client_id: 601, fs_id: 11001 }
]
```

```
mgs# lctl get_param nodemap.BirdResearchSite.ranges
```

```
[
  { id: 11, start_nid: 192.168.0.100@tcp, end_nid: 192.168.0.100@tcp }
]
```

28.7. Ensuring Consistency

Consistency issues may arise in a `nodemap` enabled configuration when Lustre clients mount from an unknown NID range, new UIDs and GIDs that were not part of a known map are

added, or there are misconfigurations in the rules. Keep in mind the following when activating nodemap on a production system:

- Creating new policy groups or idmaps on a production system is allowed, but reserve a maintenance window to alter the `trusted` property to avoid metadata problems.
- To perform administrative tasks, access the Lustre file system via a policy group with `trusted` and `admin` properties set. This prevents the creation of orphaned and squashed files. Granting the `admin` property without the `trusted` property is dangerous. The root user on the client may know of UIDs and GIDs that are not present in any idmap. If root alters ownership to those identifiers, the ownership is squashed as a result. For example, tar file extracts may be flipped from an expected UID such as UID 500 to `nobody`, normally UID 99.
- To map distinct UIDs at two or more sites onto a single UID or GID on the Lustre file system, create overlapping idmaps and place each site in its own policy group. Each distinct UID may have its own mapping onto the target UID or GID.

• **Introduced in Lustre 2.8**

In Lustre 2.8, changes must be manually kept in a script file to be re-applied after a Lustre reload, and changes must be made on each OSS, MDS, and MGS nodes, as there is no automatic synchronization between the nodes.

- If `deny_unknown` is in effect, it is possible for unmapped users to see dentries which were viewed by a mapped user. This is a result of client caching, and unmapped users will not be able to view any file contents.
- Nodemap activation status can be checked with `lctl nodemap_info`, but extra validation is possible. One way of ensuring valid deployment on a production system is to create a fingerprint of known files with specific UIDs and GIDs mapped to a test client. After bringing the Lustre system online after maintenance, the test client can validate the UIDs and GIDs map correctly before the system is mounted in user space.

Chapter 29. Configuring Shared-Secret Key (SSK) Security

This chapter describes how to configure Shared-Secret Key security and includes the following sections:

- Section 29.1, “SSK Security Overview”
- Section 29.2, “SSK Security Flavors”
- Section 29.3, “SSK Key Files”
- Section 29.4, “Lustre GSS Keyring”
- Section 29.5, “Role of Nodemap in SSK”
- Section 29.6, “SSK Examples”
- Section 29.7, “Viewing Secure PtlRPC Contexts”

29.1. SSK Security Overview

The SSK feature ensures integrity and data protection for Lustre PtlRPC traffic. Key files containing a shared secret and session-specific attributes are distributed to Lustre hosts. This authorizes Lustre hosts to mount the file system and optionally enables secure data transport, depending on which security flavor is configured. The administrator handles the generation, distribution, and installation of SSK key files, see Section 29.3.1, “Key File Management”.

29.1.1. Key features

SSK provides the following key features:

- Host-based authentication
- Data Transport Privacy
 - Encrypts Lustre RPCs
 - Prevents eavesdropping
- Data Transport Integrity - Keyed-Hashing Message Authentication Code (HMAC)
 - Prevents man-in-the-middle attacks
 - Ensures RPCs cannot be altered undetected

29.2. SSK Security Flavors

SSK is implemented as a Generic Security Services (GSS) mechanism through Lustre's support of the GSS Application Program Interface (GSSAPI). The SSK GSS mechanism supports five flavors that offer varying levels of protection.

Flavors provided:

- `skn` - SSK Null (Authentication)
- `ska` - SSK Authentication and Integrity for non-bulk RPCs
- `ski` - SSK Authentication and Integrity
- `skpi` - SSK Authentication, Privacy, and Authentication
- `gssnull` - Provides no protection. Used for testing purposes only

The table below describes the security characteristics of each flavor:

Table 29.1. SSK Security Flavor Protections

	skn	ska	ski	skpi
Required to mount file system	Yes	Yes	Yes	Yes
Provides RPC Integrity	No	Yes	Yes	Yes
Provides RPC Privacy	No	No	No	Yes
Provides Bulk RPC Integrity	No	No	Yes	Yes
Provides Bulk RPC Privacy	No	No	No	Yes

Valid non-GSS flavors include:

`null` - Provides no protection. This is the default flavor.

`plain` - Plaintext with a hash on each RPC.

29.2.1. Secure RPC Rules

Secure RPC configuration rules are written to the Lustre log (`llog`) with the `lctl` command. Rules are processed with the `llog` and dictate the security flavor that is used for a particular Lustre network and direction.

Note

Rules take affect in a matter of seconds and impact both existing and new connections.

Rule format:

`target.srpc.flavor.network[.direction]=flavor`

- `target` - This could be the file system name or a specific MDT/OST device name.
- `network` - LNet network name of the RPC initiator. For example `tcp1` or `o2ib0`. This can also be the keyword `default` that applies to all networks otherwise specified.

- *direction* - Direction is optional. This could be one of *mdt2mdt*, *mdt2ost*, *cli2mdt*, or *cli2ost*.

Note

To secure the connection to the MGS use the *mgssec=flavor* mount option. This is required because security rules are unknown to the initiator until after the MGS connection has been established.

The examples below are for a test Lustre file system named *testfs*.

29.2.1.1. Defining Rules

Rules can be defined and deleted in any order. The rule with the greatest specificity for a given connection is applied. The *fsname.srpc.flavor.default* rule is the broadest rule as it applies to all non-MGS connections for the file system in the absence of a more specific rule. You may tailor SSK security to your needs by further specifying a specific *target*, *network*, and/or *direction*.

The following example illustrates an approach to configuring SSK security for an environment consisting of three LNet networks. The requirements for this example are:

- All non-MGS connections must be authenticated.
- PtIRPC traffic on LNet network *tcp0* must be encrypted.
- LNet networks *tcp1* and *o2ib0* are local physically secure networks that require high performance. Do not encrypt PtIRPC traffic on these networks.

1. Ensure that all non-MGS connections are authenticated and encrypted by default.

```
mgs# lctl conf_param testfs.srpc.flavor.default=skpi
```

2. Override the file system default security flavor on LNet networks *tcp1* and *o2ib0* with *ska*. Security flavor *ska* provides authentication but without the performance impact of encryption and bulk RPC integrity.

```
mgs# lctl conf_param testfs.srpc.flavor.tcp1=ska  
mgs# lctl conf_param testfs.srpc.flavor.o2ib0=ska
```

Note

Currently the "`lctl set_param -P`" format does not work with `sptlrpc`.

29.2.1.2. Listing Rules

To view the Secure RPC Config Rules, enter:

```
mgs# lctl get_param mgs.*.live.testfs  
...  
Secure RPC Config Rules:  
testfs.srpc.flavor.tcp.cli2mdt=skpi  
testfs.srpc.flavor.tcp.cli2ost=skpi  
testfs.srpc.flavor.o2ib=ski  
...
```

29.2.1.3. Deleting Rules

To delete a security flavor for an LNet network use the `conf_param -d` command to delete the flavor for that network:

For example, to delete the `testfs.srpc.flavor.o2ib1=ski` rule, enter:

```
mgs# lctl conf_param -d testfs.srpc.flavor.o2ib1
```

29.3. SSK Key Files

SSK key files are a collection of attributes formatted as fixed length values and stored in a file, which are distributed by the administrator to client and server nodes. Attributes include:

- **Version** - Key file schema version number. Not user-defined.
- **Type** - A mandatory attribute that denotes the Lustre role of the key file consumer. Valid key types are:
 - **mgs** - for MGS when the `mgssec mount.lustre` option is used.
 - **server** - for MDS and OSS servers
 - **client** - for clients as well as servers who communicate with other servers in a client context (e.g. MDS communication with OSTs).
- **HMAC algorithm** - The Keyed-Hash Message Authentication Code algorithm used for integrity. Valid algorithms are (Default: SHA256):
 - SHA256
 - SHA512
- **Cryptographic algorithm** - Cipher for encryption. Valid algorithms are (Default: AES-256-CTR).
 - AES-256-CTR
- **Session security context expiration** - Seconds before session contexts generated from key expire and are regenerated (Default: 604800 seconds (7 days)).
- **Shared key length** - Shared key length in bits (Default: 256).
- **Prime length** - Length of prime (p) in bits used for the Diffie-Hellman Key Exchange (DHKE). (Default: 2048). This is generated only for client keys and can take a while to generate. This value also sets the minimum prime length that servers and MGS will accept from a client. Clients attempting to connect with a prime length less than the minimum will be rejected. In this way servers can guarantee the minimum encryption level that will be permitted.
- **File system name** - Lustre File system name for key.
- **MGS NIDs** - Comma-separated list of MGS NIDs. Only required when `mgssec` is used (Default: "").
- **Nodemap name** - Nodemap name for key (Default: "default"). See Section 29.5, "Role of Nodemap in SSK"

- **Shared key** - Shared secret used by all SSK flavors to provide authentication.
- **Prime (p)** - Prime used for the DHKE. This is only used for keys with `Type=client`.

Note

Key files provide a means to authenticate Lustre connections; always store and transfer key files securely. Key files must not be world writable or they will fail to load.

29.3.1. Key File Management

The `lgss_sk` utility is used to write, modify, and read SSK key files. `lgss_sk` can be used to load key files singularly into the kernel keyring. `lgss_sk` options include:

Table 29.2. `lgss_sk` Parameters

Parameter	Value	Description
<code>-l --load</code>	<i>filename</i>	Install key from file into user's session keyring. Must be executed by <i>root</i> .
<code>-m --modify</code>	<i>filename</i>	Modify a file's key attributes
<code>-r --read</code>	<i>filename</i>	Show file's key attributes
<code>-w --write</code>	<i>filename</i>	Generate key file
<code>-c --crypt</code>	<i>cipher</i>	Cipher for encryption (Default: AES Counter mode) AES-256-CTR
<code>-i --hmac</code>	<i>hash</i>	Hash algorithm for integrity (Default: SHA256) SHA256 or SHA512
<code>-e --expire</code>	<i>seconds</i>	Seconds before contexts from key expire (Default: 604800 (7 days))
<code>-f --fsname</code>	<i>name</i>	File system name for key
<code>-g --mgsnids</code>	<i>NID(s)</i>	Comma separated list of MGS NID(s). Only required when <code>mgssec</code> is used (Default: "")
<code>-n --nodemap</code>	<i>map</i>	Nodemap name for key (Default: "default")
<code>-p --prime-bits</code>	<i>length</i>	Prime length (p) for DHKE in bits (Default: 2048)
<code>-t --type</code>	<i>type</i>	Key type (mgs, server, client)
<code>-k --key-bits</code>	<i>length</i>	Shared key length in bits (Default: 256)
<code>-d --data</code>	<i>file</i>	Shared key random data source (Default: /dev/random)
<code>-v --verbose</code>		Increase verbosity for errors

29.3.1.1. Writing Key Files

Key files are generated by the `lgss_sk` utility. Parameters are specified on the command line followed by the `--write` parameter and the filename to write to. The `lgss_sk` utility will

not overwrite files so the filename must be unique. Mandatory parameters for generating key files are `--type`, either `--fsname` or `--mgsnids`, and `--write`; all other parameters are optional.

`lgss_sk` uses `/dev/random` as the default entropy data source; you may override this with the `--data` parameter. When no hardware random number generator is available on the system where `lgss_sk` is executing, you may need to press keys on the keyboard or move the mouse (if directly attached to the system) or cause disk IO (if system is remote), in order to generate entropy for the shared key. It is possible to use `/dev/urandom` for testing purposes but this may provide less security in some cases.

Example:

To create a *server* type key file for the *testfs* Lustre file system for clients in the *biology* nodemap, enter:

```
server# lgss_sk -t server -f testfs -n biology \  
-w testfs.server.biology.key
```

29.3.1.2. Modifying Key Files

Like writing key files you modify them by specifying the parameters on the command line that you want to change. Only key file attributes associated with the parameters provided are changed; all other attributes remain unchanged.

To modify a key file's *Type* to *client* and populate the *Prime* (*p*) key attribute, if it is missing, enter:

```
client# lgss_sk -t client -m testfs.client.biology.key
```

To add MGS NIDs `192.168.1.101@tcp,10.10.0.101@o2ib` to server key file `testfs.server.biology.key` and client key file `testfs.client.biology.key`, enter

```
server# lgss_sk -g 192.168.1.101@tcp,10.10.0.101@o2ib \  
-m testfs.server.biology.key
```

```
client# lgss_sk -g 192.168.1.101@tcp,10.10.0.101@o2ib \  
-m testfs.client.biology.key
```

To modify the `testfs.server.biology.key` on the MGS to support MGS connections from *biology* clients, modify the key file's *Type* to include *mgs* in addition to *server*, enter:

```
mgs# lgss_sk -t mgs,server -m testfs.server.biology.key
```

29.3.1.3. Reading Key Files

Read key files with the `lgss_sk` utility and `--read` parameter. Read the keys modified in the previous examples:

```
mgs# lgss_sk -r testfs.server.biology.key  
Version:          1  
Type:             mgs server  
HMAC alg:         SHA256  
Crypt alg:        AES-256-CTR  
Ctx Expiration:  604800 seconds
```

```

Shared keylen: 256 bits
Prime length: 2048 bits
File system: testfs
MGS NIDs: 192.168.1.101@tcp 10.10.0.101@o2ib
Nodemap name: biology
Shared key:
  0000: 84d2 561f 37b0 4a58 de62 8387 217d c30a ..V.7.JX.b...!}..
  0010: 1caa d39c b89f ee6c 2885 92e7 0765 c917 .....l(.....e..

```

```
client# lgss_sk -r testfs.client.biology.key
```

```

Version: 1
Type: client
HMAC alg: SHA256
Crypt alg: AES-256-CTR
Ctx Expiration: 604800 seconds
Shared keylen: 256 bits
Prime length: 2048 bits
File system: testfs
MGS NIDs: 192.168.1.101@tcp 10.10.0.101@o2ib
Nodemap name: biology
Shared key:
  0000: 84d2 561f 37b0 4a58 de62 8387 217d c30a ..V.7.JX.b...!}..
  0010: 1caa d39c b89f ee6c 2885 92e7 0765 c917 .....l(.....e..

```

```

Prime (p) :
  0000: 8870 c3e3 09a5 7091 ae03 f877 f064 c7b5 .p....p....w.d..
  0010: 14d9 bc54 75f8 80d3 22f9 2640 0215 6404 ...Tu...".&@..d.
  0020: 1c53 ba84 1267 bea2 fb05 37a4 ed2d 5d90 .S...g....7...-].
  0030: 84e3 1a67 67f0 47c7 0c68 5635 f50e 9cf0 ...gg.G..hV5....
  0040: e622 6f53 2627 6af6 9598 eed 6290 9b1e ."oS&'j.....b...
  0050: 2ec5 df04 884a ea12 9f24 cadc e4b6 e91d .....J....$.
  0060: 362f a239 0a6d 0141 b5e0 5c56 9145 6237 6/.9.m.A..\V.Eb7
  0070: 59ed 3463 90d7 1cbe 28d5 a15d 30f7 528b Y.4c....(..]0.R.
  0080: 76a3 2557 e585 albe c741 2a81 0af0 2181 v.%W.....A*...!.
  0090: 93cc a17a 7e27 6128 5ebd e0a4 3335 db63 ...z~'a(^...35.c
  00a0: c086 8d0d 89c1 c203 3298 2336 59d8 d7e7 .....2.#6Y...
  00b0: e52a b00c 088f 71c3 5109 ef14 3910 fcf6 .*....q.Q...9...
  00c0: 0fa0 7db7 4637 bb95 75f4 eb59 b0cd 4077 ..}.F7..u..Y..@w
  00d0: 8f6a 2ebd f815 a9eb 1b77 c197 5100 84c0 .j.....w..Q...
  00e0: 3dc0 d75d 40b3 6be5 a843 751a b09c 1b20 =..]@.k..Cu....
  00f0: 8126 4817 e657 b004 06b6 86fb 0e08 6a53 .&H..W.....js

```

29.3.1.4. Loading Key Files

Key files can be loaded into the kernel keyring with the `lgss_sk` utility or at mount time with the `skpath` mount option. The `skpath` method has the advantage that it accepts a directory path and loads all key files within the directory into the keyring. The `lgss_sk` utility loads a single key file into the keyring with each invocation. Key files must not be world writable or they will fail to load.

Third party tools can also load the keys if desired. The only caveat is that the key must be available when the `request_key` upcall to userspace is made and they use the correct key descriptions for a key so that it can be found during the upcall (see Key Descriptions).

Examples:

Load the `testfs.server.biology.key` key file using `lgss_sk`, enter:

```
server# lgss_sk -l testfs.server.biology.key
```

Use the `skpath` mount option to load all of the key files in the `/secure_directory` directory when mounting a storage target, enter:

```
server# mount -t lustre -o skpath=/secure_directory \  
/storage/target /mount/point
```

Use the `skpath` mount option to load key files into the keyring on a client, enter:

```
client# mount -t lustre -o skpath=/secure_directory \  
mgsnode:/testfs /mnt/testfs
```

29.4. Lustre GSS Keyring

The Lustre GSS Keyring binary `lgss_keyring` is used by SSK to handle the upcall from kernel space into user space via `request-key`. The purpose of `lgss_keyring` is to create a token that is passed as part of the security context initialization RPC (`SEC_CTX_INIT`)

29.4.1. Setup

The Lustre GSS keyring types of flavors utilize the Linux kernel keyring infrastructure to maintain keys as well as to perform the upcall from kernel space to userspace for key negotiation/establishment. The GSS keyring establishes a key type (see “`request-key(8)`”) named `lgssc` when the Lustre `ptlrpc_gss` kernel module is loaded. When a security context must be established it creates a key and uses the `request-key` binary in an upcall to establish the key. This key will look for the configuration file in `/etc/request-key.d` with the name `keytype.conf`, for Lustre this is `lgssc.conf`.

Each node participating in SSK Security must have a `/etc/request-key.d/` `lgssc.conf` file that contains the following single line:

```
create lgssc * * /usr/sbin/lgss_keyring %o %k %t %d %c %u %g  
%T %P %S
```

The `request-key` binary will call `lgss_keyring` with the arguments following it with their substituted values (see `request-key.conf(5)`).

29.4.2. Server Setup

Lustre servers do not use the Linux `request-key` mechanism as clients do. Instead servers run a daemon that uses a pipefs with the kernel to trigger events based on read/write to a file descriptor. The server-side binary is `lsvcgssd`. It can be executed in the foreground or as a daemon. Below are the parameters for the `lsvcgssd` binary which requires various security flavors (`gssnull`, `krb5`, `sk`) to be enabled explicitly. This ensures that only required functionality is enabled.

Table 29.3. lsvcgssd Parameters

Parameter	Description
<code>-f</code>	Run in foreground

Parameter	Description
-n	Do not establish Kerberos credentials
-v	Verbosity
-m	Service MDS
-o	Service OSS
-g	Service MGS
-k	Enable Kerberos support
-s	Enable Shared Key support
-z	Enable gssnull support

A SysV style init script is installed for starting and stopping the `lsvcgssd` daemon. The init script checks the `LSVCGSSARGS` variable in the `/etc/sysconfig/lsvcgss` configuration file for startup parameters.

Keys during the upcall on the client and handling of an RPC on the server are found by using a specific key description for each key in the kernel keyring.

For each MGS NID there must be a separate key loaded. The format of the key description should be:

Table 29.4. Key Descriptions

Type	Key Description	Example
MGC	<code>lustre:MGCNID</code>	<code>lustre:MGC192.168.1.10@tcp</code>
MDC/OSC/ OSP/LWP	<code>lustre:fsname</code>	<code>lustre:testfs</code>
MDT	<code>lustre:fsname:NodemapName</code>	<code>lustre:testfs:biology</code>
OST	<code>lustre:fsname:NodemapName</code>	<code>lustre:testfs:biology</code>
MGS	<code>lustre:MGS</code>	<code>lustre:MGS</code>

All keys for Lustre use the `user` type for keys and are attached to the user's keyring. This is not configurable. Below is an example showing how to list the user's keyring, load a key file, read the key, and clear the key from the kernel keyring.

```

client# keyctl show
Session Keyring
 17053352 --alswrv      0      0  keyring: _ses
 773000099 --alswrv    0 65534  \_ keyring: _uid.0

client# lgss_sk -l /secure_directory/testfs.client.key

client# keyctl show
Session Keyring
 17053352 --alswrv      0      0  keyring: _ses
 773000099 --alswrv    0 65534  \_ keyring: _uid.0
1028795127 --alswrv    0      0  \_ user: lustre:testfs

client# keyctl pipe 1028795127 | lgss_sk -r -
Version:          1

```

```

Type:                client
HMAC alg:            SHA256
Crypt alg:           AES-256-CTR
Ctx Expiration:     604800 seconds
Shared keylen:      256 bits
Prime length:       2048 bits
File system:        testfs
MGS NIDs:
Nodemap name:      default
Shared key:
  0000: faaf 85da 93d0 6ffc f38c a5c6 f3a6 0408 .....o.....
  0010: 1e94 9b69 cf82 d0b9 880b f173 c3ea 787a ...i.....s...xz
Prime (p) :
  0000: 9c12 ed95 7b9d 275a 229e 8083 9280 94a0 ....{'Z".....
  0010: 8593 16b2 a537 aa6f 8b16 5210 3dd5 4c0c .....7.o..R.=.L.
  0020: 6fae 2729 fcea 4979 9435 f989 5b6e 1b8a o.')..Iy.5..[n..
  0030: 5039 8db2 3a23 31f0 540c 33cb 3b8e 6136 P9...:#1.T.3.;.a6
  0040: ac18 1eba f79f c8dd 883d b4d2 056c 0501 .....=...l..
  0050: ac17 a4ab 9027 4930 1d19 7850 2401 7ac4 .....'I0...xP$.z.
  0060: 92b4 2151 8837 ba23 94cf 22af 72b3 e567 ..!Q.7.#..."r..g
  0070: 30eb 0cd4 3525 8128 b0ff 935d 0ba3 0fc0 0...5%.(...)]...
  0080: 9afa 5da7 0329 3ce9 e636 8a7d c782 6203 ..]..)<...6.}.b.
  0090: bb88 012e 61e7 5594 4512 4e37 e01d bdfc ....a.U.E.N7....
  00a0: cb1d 6bd2 6159 4c3a 1f4f 1167 0e26 9e5e ..k.aYL:.O.g.&.^
  00b0: 3cdc 4a93 63f6 24b1 e0f1 ed77 930b 9490 <.J.c.$....w....
  00c0: 25ef 4718 bff5 033e 11ba e769 4969 8a73 %.G....>...iIi.s
  00d0: 9f5f b7bb 9fa0 7671 79a4 0d28 8a80 1ea1 _.....vqy..(....
  00e0: a4df 98d6 e20e fe10 8190 5680 0d95 7c83 .....V...|.
  00f0: 6e21 abb3 a303 ff55 0aa8 ad89 b8bf 7723 n!.....U.....w#

```

```
client# keyctl clear @u
```

```
client# keyctl show
```

```

Session Keyring
 17053352 --alswrv      0      0  keyring: _ses
 773000099 --alswrv    0 65534  \_ keyring: _uid.0

```

29.4.3. Debugging GSS Keyring

Lustre client and server support several debug levels, which can be seen below.

Debug levels:

- 0 - Error
- 1 - Warn
- 2 - Info
- 3 - Debug
- 4 - Trace

To set the debug level on the client use the Lustre parameter:

```
sptlrpc.gss.lgss_keyring.debug_level
```

For example to set the debug level to trace, enter:

```
client# lctl set_param sptlrpc.gss.lgss_keyring.debug_level=4
```

Server-side verbosity is increased by adding additional verbose flags (-v) to the command line arguments for the daemon. The following command runs the `lsvcgssd` daemon in the foreground with debug verbosity supporting gssnull and SSK

```
server# lsvcgssd -f -vvv -z -s
```

`lgss_keyring` is called as part of the `request-key` upcall which has no standard output; therefore logging is done through syslog. The server-side logging with `lsvcgssd` is written to standard output when executing in the foreground and to syslog in daemon mode.

29.4.4. Revoking Keys

The keys discussed above with `lgss_sk` and the `skpath` mount options are not revoked. They are only used to create valid contexts for client connections. Instead of revoking them they can be invalidated in one of two ways.

- Unloading the key from the user keyring on the server will cause new client connections to fail. If no longer necessary it can be deleted.
- Changing the nodemap name for the clients on the servers. Since the nodemap is an integral part of the shared key context instantiation, renaming the nodemap a group of NIDs belongs to will prevent any new contexts.

There currently does not exist a mechanism to flush contexts from Lustre. Targets could be unmounted from the servers to purge contexts. Alternatively shorter context expiration could be used when the key is created so that contexts need to be refreshed more frequently than the default. 3600 seconds could be reasonable depending on the use case so that contexts will have to be renegotiated every hour.

29.5. Role of Nodemap in SSK

SSK uses Nodemap (See Chapter 28, *Mapping UIDs and GIDs with Nodemap*) policy group names and their associated NID range(s) as a mechanism to prevent key file forgery, and to control the range of NIDs on which a given key file can be used.

Clients assume they are in the nodemap specified in the key file they use. When clients instantiate security contexts an upcall is triggered that specifies information about the context that triggers it. From this context information `request-key` calls `lgss_keyring`, which in turn looks up the key with description `lustre:fsname` or `lustre:target_name` for the MGC. Using the key found in the user keyring matching the description, the nodemap name is read from the key, hashed with SHA256, and sent to the server.

Servers look up the client's NID to determine which nodemap the NID is associated with and sends the nodemap name to `lsvcgssd`. The `lsvcgssd` daemon verifies whether the HMAC equals the nodemap value sent by the client. This prevents forgery and invalidates the key when a client's NID is not associated with the nodemap name defined on the servers.

It is not required to activate the Nodemap feature in order for SSK to perform client NID to nodemap name lookups.

29.6. SSK Examples

The examples in this section use 1 MGS/MDS (NID 172.16.0.1@tcp), 1 OSS (NID 172.16.0.3@tcp), and 2 clients. The Lustre file system name is *testfs*.

29.6.1. Securing Client to Server Communications

This example illustrates how to configure SSK to apply Privacy and Integrity protections to client-to-server PtIRPC traffic on the `tcp` network. Rules that specify a direction, specifically `cli2mdt` and `cli2ost`, are used. This permits server-to-server communications to continue using `null` which is the *default* flavor for all Lustre connections. This arrangement provides no server-to-server protections, see Section 29.6.3, “Securing Server to Server Communications”.

1. Create secure directory for storing SSK key files.

```
mds# mkdir /secure_directory
mds# chmod 600 /secure_directory
oss# mkdir /secure_directory
oss# chmod 600 /secure_directory
cli1# mkdir /secure_directory
cli1# chmod 600 /secure_directory
cli2# mkdir /secure_directory
cli2# chmod 600 /secure_directory
```

2. Generate a key file for the MDS and OSS servers. Run:

```
mds# lgss_sk -t server -f testfs -w \
/secure_directory/testfs.server.key
```

3. Securely copy the `/secure_directory/testfs.server.key` key file to the OSS.

```
mds# scp /secure_directory/testfs.server.key \
oss:/secure_directory/
```

4. Securely copy the `/secure_directory/testfs.server.key` key file to `/secure_directory/testfs.client.key` on *client1*.

```
mds# scp /secure_directory/testfs.server.key \
client1:/secure_directory/testfs.client.key
```

5. Modify the key file type to `client` on *client1*. This operation also generates a prime number of Prime length to populate the Prime (`p`) attribute. Run:

```
client1# lgss_sk -t client \
-m /secure_directory/testfs.client.key
```

6. Create a `/etc/request-key.d/lgssc.conf` file on all nodes that contains this line `'create lgssc * * /usr/sbin/lgssc_keyring %o %k %t %d %c %u %g %T %P %S'` without the single quotes. Run:

```
mds# echo create lgssc \* \* /usr/sbin/lgssc_keyring %o %k %t %d %c %u %g
oss# echo create lgssc \* \* /usr/sbin/lgssc_keyring %o %k %t %d %c %u %g
client1# echo create lgssc \* \* /usr/sbin/lgssc_keyring %o %k %t %d %c %
client2# echo create lgssc \* \* /usr/sbin/lgssc_keyring %o %k %t %d %c %
```

7. Configure the `lsvcgss` daemon on the MDS and OSS. Set the `LSVCGSSDARGS` variable in `/etc/sysconfig/lsvcgss` on the MDS to `'-s -m'`. On the OSS, set the `LSVCGSSDARGS` variable in `/etc/sysconfig/lsvcgss` to `'-s -o'`

8. Start the `lsvcgssd` daemon on the MDS and OSS. Run:

```
mgs# systemctl start lsvcgss.service
oss# systemctl start lsvcgss.service
```

9. Mount the MDT and OST with the `-o skpath=/secure_directory` mount option. The `skpath` option loads all SSK key files found in the directory into the kernel keyring.

10. Set client to MDT and client to OST security flavor to SSK Privacy and Integrity, `skpi`:

```
mgs# lctl conf_param testfs.srpc.flavor.tcp.cli2mdt=skpi
mgs# lctl conf_param testfs.srpc.flavor.tcp.cli2ost=skpi
```

11. Mount the `testfs` file system on `client1` and `client2`:

```
client1# mount -t lustre -o skpath=/secure_directory 172.16.0.1@tcp:/testfs
client2# mount -t lustre -o skpath=/secure_directory 172.16.0.1@tcp:/testfs
mount.lustre: mount 172.16.0.1@tcp:/testfs at /mnt/testfs failed: Connec
```

12. `client2` failed to authenticate because it does not have a valid key file. Repeat steps 4 and 5, substitute `client1` for `client2`, then mount the `testfs` file system on `client2`:

```
client2# mount -t lustre -o skpath=/secure_directory 172.16.0.1@tcp:/tes
```

13. Verify that the `mdc` and `osc` connections are using the SSK mechanism and that `rpc` and `bulk` security flavors are `skpi`. See Section 29.7, “Viewing Secure PtlRPC Contexts”.

Notice the `mgc` connection to the MGS has no secure PtlRPC security context. This is because `skpi` security was only specified for client-to-MDT and client-to-OST connections in step 10. The following example details the steps necessary to secure the connection to the MGS.

29.6.2. Securing MGS Communications

This example builds on the previous example.

1. Enable `lsvcgss` MGS service support on MGS. Edit `/etc/sysconfig/lsvcgss` on the MGS and add the `(-g)` parameter to the `LSVCGSSDARGS` variable. Restart the `lsvcgss` service.

2. Add `mgs` key type and `MGS NIDs` to `/secure_directory/testfs.server.key` on MDS.

```
mgs# lgss_sk -t mgs,server -g 172.16.0.1@tcp,172.16.0.2@tcp -m /secure_d
```

3. Load the modified key file on the MGS. Run:

```
mgs# lgss_sk -l /secure_directory/testfs.server.key
```

4. Add `MGS NIDs` to `/secure_directory/testfs.client.key` on client, `client1`.

```
client1# lgss_sk -g 172.16.0.1@tcp,172.16.0.2@tcp -m /secure_directory/t
```

5. Unmount the testfs file system on client1, then mount with the `mgssec=skpi` mount option:

```
cli1# mount -t lustre -o mgssec=skpi,skpath=/secure_directory 172.16.0.1
```

6. Verify that client1's MGC connection is using the SSK mechanism and `skpi` security flavor. See Section 29.7, "Viewing Secure PtIRPC Contexts".

29.6.3. Securing Server to Server Communications

This example illustrates how to configure SSK to apply *Integrity* protection, *ski* flavor, to MDT-to-OST PtIRPC traffic on the `tcp` network.

This example builds on the previous example.

1. Create a Nodemap policy group named `LustreServers` on the MGS for the Lustre Servers, enter:

```
mgs# lctl nodemap_add LustreServers
```

2. Add MDS and OSS NIDs to the `LustreServers` nodemap, enter:

```
mgs# lctl nodemap_add_range --name LustreServers --range 172.16.0.[1-3]@
```

3. Create key file of type `mgs,server` for use with nodes in the `LustreServers` Nodemap range.

```
mgs# lgss_sk -t mgs,server -f testfs -g \  
172.16.0.1@tcp,172.16.0.2@tcp -n LustreServers -w \  
/secure_directory/testfs.LustreServers.key
```

4. Securely copy the `/secure_directory/testfs.LustreServers.key` key file to the OSS.

```
mgs# scp /secure_directory/testfs.LustreServers.key oss:/secure_directory
```

5. On the MDS and OSS, copy `/secure_directory/testfs.LustreServers.key` to `/secure_directory/testfs.LustreServers.client.key`.

6. On each server modify the key file type of `/secure_directory/testfs.LustreServers.client.key` to be of type `client`. This operation also generates a prime number of *Prime length* to populate the *Prime (p)* attribute. Run:

```
mgs# lgss_sk -t client -m \  
/secure_directory/testfs.LustreServers.client.key  
oss# lgss_sk -t client -m \  
/secure_directory/testfs.LustreServers.client.key
```

7. Load the `/secure_directory/testfs.LustreServers.key` and `/secure_directory/testfs.LustreServers.client.key` key files into the keyring on the MDS and OSS, enter:

```
mgs# lgss_sk -l /secure_directory/testfs.LustreServers.key  
mgs# lgss_sk -l /secure_directory/testfs.LustreServers.client.key  
oss# lgss_sk -l /secure_directory/testfs.LustreServers.key
```

```
oss# lgss_sk -l /secure_directory/testfs.LustreServers.client1.key
```

8. Set MDT to OST security flavor to SSK Integrity, ski:

```
mds# lctl conf_param testfs.srpc.flavor.tcp.mdt2ost=ski
```

9. Verify that the osc and osp connections to the OST have a secure ski security context.
See Section 29.7, “Viewing Secure PtIRPC Contexts”.

29.7. Viewing Secure PtIRPC Contexts

From the client (or servers which have mgc, osc, mdc contexts) you can view info regarding all users' contexts and the flavor in use for an import. For user's contexts (srpc_context), SSK and gssnull only support a single root UID so there should only be one context. The other file in the import (srpc_info) has additional splrpc details. The rpc and bulk flavors allow you to verify which security flavor is in use.

```
client1# lctl get_param *.*.srpc_*
mdc.testfs-MDT0000-mdc-ffff8800da9f0800.srpc_contexts=
ffff8800da9600c0: uid 0, ref 2, expire 1478531769(+604695), fl uptodate,ca
mdc.testfs-MDT0000-mdc-ffff8800da9f0800.srpc_info=
rpc flavor:      skpi
bulk flavor:    skpi
flags:          rootonly,udesc,
id:             3
refcount:      3
nctx:          1
gc internal    3600
gc next 3505
mgc.MGC172.16.0.1@tcp.srpc_contexts=
ffff8800dbb09b40: uid 0, ref 2, expire 1478531769(+604695), fl uptodate,ca
mgc.MGC172.16.0.1@tcp.srpc_info=
rpc flavor:      skpi
bulk flavor:    skpi
flags:          -,
id:             2
refcount:      3
nctx:          1
gc internal    3600
gc next 3505
osc.testfs-OST0000-osc-ffff8800da9f0800.srpc_contexts=
ffff8800db9e5600: uid 0, ref 2, expire 1478531770(+604696), fl uptodate,ca
osc.testfs-OST0000-osc-ffff8800da9f0800.srpc_info=
rpc flavor:      skpi
bulk flavor:    skpi
flags:          rootonly,bulk,
id:             6
refcount:      3
nctx:          1
gc internal    3600
gc next 3505
```

Chapter 30. Managing Security in a Lustre File System

This chapter describes security features of the Lustre file system and includes the following sections:

- Section 30.1, “Using ACLs”
- Section 30.2, “Using Root Squash”
- Section 30.3, “Isolating Clients to a Sub-directory Tree”
- Section 30.4, “Checking SELinux Policy Enforced by Lustre Clients”
- Section 30.5, “Encrypting files and directories”
- Section 30.6, “Configuring Kerberos (KRB) Security”

30.1. Using ACLs

An access control list (ACL), is a set of data that informs an operating system about permissions or access rights that each user or group has to specific system objects, such as directories or files. Each object has a unique security attribute that identifies users who have access to it. The ACL lists each object and user access privileges such as read, write or execute.

30.1.1. How ACLs Work

Implementing ACLs varies between operating systems. Systems that support the Portable Operating System Interface (POSIX) family of standards share a simple yet powerful file system permission model, which should be well-known to the Linux/UNIX administrator. ACLs add finer-grained permissions to this model, allowing for more complicated permission schemes. For a detailed explanation of ACLs on a Linux operating system, refer to the SUSE Labs article [Posix Access Control Lists on Linux \[https://www.usenix.org/legacyurl/posix-access-control-lists-linux\]](https://www.usenix.org/legacyurl/posix-access-control-lists-linux).

We have implemented ACLs according to this model. The Lustre software works with the standard Linux ACL tools, `setfacl`, `getfacl`, and the historical `chacl`, normally installed with the ACL package.

Note

ACL support is a system-range feature, meaning that all clients have ACL enabled or not. You cannot specify which clients should enable ACL.

30.1.2. Using ACLs with the Lustre Software

POSIX Access Control Lists (ACLs) can be used with the Lustre software. An ACL consists of file entries representing permissions based on standard POSIX file system object permissions that define three classes of user (owner, group and other). Each class is associated with a set of permissions [read (r), write (w) and execute (x)].

- Owner class permissions define access privileges of the file owner.
- Group class permissions define access privileges of the owning group.

- Other class permissions define access privileges of all users not in the owner or group class.

The `ls -l` command displays the owner, group, and other class permissions in the first column of its output (for example, `-rw-r--` for a regular file with read and write access for the owner class, read access for the group class, and no access for others).

Minimal ACLs have three entries. Extended ACLs have more than the three entries. Extended ACLs also contain a mask entry and may contain any number of named user and named group entries.

To check ACLs on the MDS, check that the `acl connect` flag is listed (default since Lustre 1.8):

```
# lctl get_param -n mdc.home-MDT0000-mdc-*.connect_flags | grep acl
```

ACLs are enabled by default on a Lustre file system, and are controlled on a system-wide basis; either all clients enable ACLs or none do. Activating ACLs is controlled by MDS mount options `acl/noacl` to enable or disable ACLs, respectively. You do not need to change the client configuration, and the `acl` string will not appear in the client mount options in `/etc/mtab`.

If ACLs are not enabled on the MDS, then any attempts to reference an ACL on a client return an `Operation not supported` error.

30.1.3. Examples

These examples are taken directly from the POSIX paper referenced above. ACLs on a Lustre file system work exactly like ACLs on any Linux file system. They are manipulated with the standard tools in the standard manner. Below, we create a directory and allow a specific user access.

```
[phil@client lustre]$ umask 027
[phil@client lustre]$ mkdir rain
[phil@client lustre]$ ls -ld rain
drwxr-x--- 2 phil dev 4096 Feb 20 06:50 rain
[phil@client lustre]$ getfacl rain
# file: rain
# owner: phil
# group: dev
user::rwx
group::r-x
other::---
```

```
[phil@client lustre]$ setfacl -m user:chirag:rwx rain
[phil@client lustre]$ ls -ld rain
drwxrwx---+ 2 phil dev 4096 Feb 20 06:50 rain
[phil@client lustre]$ getfacl --omit-header rain
user::rwx
user:chirag:rwx
group::r-x
mask::rwx
other::---
```

30.2. Using Root Squash

Root squash is a security feature which restricts super-user access rights to a Lustre file system. Without the root squash feature enabled, Lustre file system users on untrusted clients could access or modify files

owned by root on the file system, including deleting them. Using the root squash feature restricts file access/modifications as the root user. Note, however, that this does *not* prevent users from accessing files owned by *other* users.

The root squash feature works by re-mapping the user ID (UID) and group ID (GID) of the root user to a UID and GID specified by the system administrator. The preferred way to configure root squash is via nodemaps and the `admin` property. Nodemaps allow root squash on a per-client basis. With UID maps, the clients can even have a local root UID without actually having root access to the filesystem itself.

Please refer to explanations about the `admin` property in the chapter dedicated to Nodemaps, in Section 28.3.1, “Managing the Properties”.

30.3. Isolating Clients to a Sub-directory Tree

Isolation is the Lustre implementation of the generic concept of multi-tenancy, which aims at providing separated namespaces from a single filesystem. Lustre Isolation enables different populations of users on the same file system beyond normal Unix permissions/ACLs, even when users on the clients may have root access. Those tenants share the same file system, but they are isolated from each other: they cannot access or even see each other’s files, and are not aware that they are sharing common file system resources.

Lustre Isolation leverages the Fileset feature (Section 44.16.3, “Fileset Feature”) to mount only a subdirectory of the filesystem rather than the root directory. In order to achieve isolation, the subdirectory mount, which presents to tenants only their own fileset, has to be imposed to the clients. To that extent, we make use of the nodemap feature (Chapter 28, *Mapping UIDs and GIDs with Nodemap*). We group all clients used by a tenant under a common nodemap entry, and we assign to this nodemap entry the fileset to which the tenant is restricted.

30.3.1. Identifying Clients

Enforcing multi-tenancy on Lustre relies on the ability to properly identify the client nodes used by a tenant, and trust those identities. This can be achieved by having physical hardware and/or network security, so that client nodes have well-known NIDs. It is also possible to make use of strong authentication with Kerberos or Shared-Secret Key (see Chapter 29, *Configuring Shared-Secret Key (SSK) Security*). Kerberos prevents NID spoofing, as every client needs its own credentials, based on its NID, in order to connect to the servers. Shared-Secret Key also prevents tenant impersonation, because keys can be linked to a specific nodemap. See Section 29.5, “Role of Nodemap in SSK” for detailed explanations.

30.3.2. Configuring Isolation

Isolation on Lustre can be achieved by setting the `fileset` parameter on a nodemap entry. All clients belonging to this nodemap entry will automatically mount this fileset instead of the root directory. For example:

```
mgs# lctl nodemap_set_fileset --name tenant1 --fileset '/dir1'
```

So all clients matching the `tenant1` nodemap will be automatically presented the fileset `/dir1` when mounting. This means these clients are doing an implicit subdirectory mount on the subdirectory `/dir1`.

Note

If subdirectory defined as fileset does not exist on the file system, it will prevent any client belonging to the nodemap from mounting Lustre.

To delete the fileset parameter, just set it to an empty string:

```
mgs# lctl nodemap_set_fileset --name tenant1 --fileset ''
```

30.3.3. Making Isolation Permanent

In order to make isolation permanent, the fileset parameter on the nodemap has to be set with `lctl set_param` with the `-P` option.

```
mgs# lctl set_param nodemap.tenant1.fileset=/dir1  
mgs# lctl set_param -P nodemap.tenant1.fileset=/dir1
```

This way the fileset parameter will be stored in the Lustre config logs, letting the servers retrieve the information after a restart.

Introduced in Lustre 2.13

30.4. Checking SELinux Policy Enforced by Lustre Clients

SELinux provides a mechanism in Linux for supporting Mandatory Access Control (MAC) policies. When a MAC policy is enforced, the operating system's (OS) kernel defines application rights, firewalling applications from compromising the entire system. Regular users do not have the ability to override the policy.

One purpose of SELinux is to protect the **OS** from privilege escalation. To that extent, SELinux defines confined and unconfined domains for processes and users. Each process, user, file is assigned a security context, and rules define the allowed operations by processes and users on files.

Another purpose of SELinux can be to protect **data** sensitivity, thanks to Multi-Level Security (MLS). MLS works on top of SELinux, by defining the concept of security levels in addition to domains. Each process, user and file is assigned a security level, and the model states that processes and users can read the same or lower security level, but can only write to their own or higher security level.

From a file system perspective, the security context of files must be stored permanently. Lustre makes use of the `security.selinux` extended attributes on files to hold this information. Lustre supports SELinux on the client side. All you have to do to have MAC and MLS on Lustre is to enforce the appropriate SELinux policy (as provided by the Linux distribution) on all Lustre clients. No SELinux is required on Lustre servers.

Because Lustre is a distributed file system, the specificity when using MLS is that Lustre really needs to make sure data is always accessed by nodes with the SELinux MLS policy properly enforced. Otherwise, data is not protected. This means Lustre has to check that SELinux is properly enforced on client side, with the right, unaltered policy. And if SELinux is not enforced as expected on a client, the server denies its access to Lustre.

30.4.1. Determining SELinux Policy Info

A string that represents the SELinux Status info will be used by servers as a reference, to check if clients are enforcing SELinux properly. This reference string can be obtained on a client node known to enforce the right SELinux policy, by calling the `l_getsepol` command line utility:

```
client# l_getsepol  
SELinux status info: 1:mls:31:40afb76d077c441b69af58cccaaa2ca63641ed6e21b0a887dc21
```

The string describing the SELinux policy has the following syntax:

```
mode:name:version:hash
```

where:

- mode is a digit telling if SELinux is in Permissive mode (0) or Enforcing mode (1)
- name is the name of the SELinux policy
- version is the version of the SELinux policy
- hash is the computed hash of the binary representation of the policy, as exported in `/etc/selinux/name/policy/policy.version`

30.4.2. Enforcing SELinux Policy Check

SELinux policy check can be enforced by setting the `sepol` parameter on a `nodemap` entry. All clients belonging to this `nodemap` entry must enforce the SELinux policy described by this parameter, otherwise they are denied access to the Lustre file system. For example:

```
mgms# lctl nodemap_set_sepol --name restricted
      --sepol '1:mls:31:40afb76d077c441b69af58cccaa2ca63641ed6e21b0a887dc21a684f508b78f'
```

So all clients matching the `restricted` `nodemap` must enforce the SELinux policy which description matches

```
1:mls:31:40afb76d077c441b69af58cccaa2ca63641ed6e21b0a887dc21a684f508b78f.
```

If not, they will get Permission Denied when trying to mount or access files on the Lustre file system.

To delete the `sepol` parameter, just set it to an empty string:

```
mgms# lctl nodemap_set_sepol --name restricted --sepol ''
```

See Chapter 28, *Mapping UIDs and GIDs with Nodemap* for more details about the Nodemap feature.

30.4.3. Making SELinux Policy Check Permanent

In order to make SELinux Policy check permanent, the `sepol` parameter on the `nodemap` has to be set with `lctl set_param` with the `-P` option.

```
mgms# lctl set_param nodemap.restricted.sepol=1:mls:31:40afb76d077c441b69af58cccaa2ca63641ed6e21b0a887dc21a684f508b78f
mgms# lctl set_param -P nodemap.restricted.sepol=1:mls:31:40afb76d077c441b69af58cccaa2ca63641ed6e21b0a887dc21a684f508b78f
```

This way the `sepol` parameter will be stored in the Lustre config logs, letting the servers retrieve the information after a restart.

30.4.4. Sending SELinux Status Info from Clients

In order for Lustre clients to send their SELinux status information, in case SELinux is enabled locally, the `send_sepol` `ptlrpc` kernel module's parameter has to be set to a non-zero value. `send_sepol` accepts various values:

- 0: do not send SELinux policy info;
- -1: fetch SELinux policy info for every request;
- $N > 0$: only fetch SELinux policy info every N seconds. Use $N = 2^{31}-1$ to have SELinux policy info fetched only at mount time.

Clients that are part of a nodemap on which `sepol` is defined must send SELinux status info. And the SELinux policy they enforce must match the representation stored into the nodemap. Otherwise they will be denied access to the Lustre file system.

Introduced in Lustre 2.14

30.5. Encrypting files and directories

The purpose that client-side encryption wants to serve is to be able to provide a special directory for each user, to safely store sensitive files. The goals are to protect data in transit between clients and servers, and protect data at rest.

This feature is implemented directly at the Lustre client level. Lustre client-side encryption relies on kernel `fsencrypt`. `fsencrypt` is a library which filesystems can hook into to support transparent encryption of files and directories. As a consequence, the key points described below are extracted from `fsencrypt` documentation.

For full details, please refer to documentation available with the Lustre sources, under the `Documentation/client_side_encryption` directory.

Note

The client-side encryption feature is available natively on Lustre clients running a Linux distribution with at least kernel 5.4. It is also available thanks to an additional kernel library provided by Lustre, on clients that run a Linux distribution with basic support for encryption, including:

- CentOS/RHEL 8.1 and later;
- Ubuntu 18.04 and later;
- SLES 15 SP2 and later.

30.5.1. Client-side encryption access semantics

Only Lustre clients need access to encryption master keys. Keys are added to the filesystem-level encryption keyring on the Lustre client.

- **With the key**

With the encryption key, encrypted regular files, directories, and symlinks behave very similarly to their unencrypted counterparts --- after all, the encryption is intended to be transparent. However, astute users may notice some differences in behavior:

- Unencrypted files, or files encrypted with a different encryption policy (i.e. different key, modes, or flags), cannot be renamed or linked into an encrypted directory. However, encrypted files can be renamed within an encrypted directory, or into an unencrypted directory.

Note

"moving" an unencrypted file into an encrypted directory, e.g. with the `mv` program, is implemented in userspace by a copy followed by a delete. Be aware the original unencrypted data may remain recoverable from free space on the disk; it is best to keep all files encrypted from the very beginning.

- On Lustre, Direct I/O is supported for encrypted files.
- The `fallocate()` operations `FALLOC_FL_COLLAPSE_RANGE`, `FALLOC_FL_INSERT_RANGE`, and `FALLOC_FL_ZERO_RANGE` are not supported on encrypted files and will fail with `EOPNOTSUPP`.
- DAX (Direct Access) is not supported on encrypted files.

Introduced in Lustre 2.15

The `st_size` of an encrypted symlink will not necessarily give the length of the symlink target as required by POSIX. It will actually give the length of the ciphertext, which will be slightly longer than the plaintext due to NUL-padding and an extra 2-byte overhead.

Introduced in Lustre 2.15

The maximum length of an encrypted symlink is 2 bytes shorter than the maximum length of an unencrypted symlink.

- `mmap` is supported. This is possible because the pagecache for an encrypted file contains the plaintext, not the ciphertext.
- **Without the key**
Some filesystem operations may be performed on encrypted regular files, directories, and symlinks even before their encryption key has been added, or after their encryption key has been removed:
 - File metadata may be read, e.g. using `stat()`.

Introduced in Lustre 2.15

Directories may be listed, in which case the filenames will be listed in an encoded form derived from their ciphertext. The algorithm is subject to change but it is guaranteed that the presented filenames will be no longer than `NAME_MAX` bytes, will not contain the `/` or `\0` characters, and will uniquely identify directory entries. The `.` and `..` directory entries are special. They are always present and are not encrypted or encoded.

- Files may be deleted. That is, nondirectory files may be deleted with `unlink()` as usual, and empty directories may be deleted with `rmdir()` as usual. Therefore, `rm` and `rm -r` will work as expected.
- Symlink targets may be read and followed, but they will be presented in encrypted form, similar to filenames in directories. Hence, they are unlikely to point to anywhere useful.

Without the key, regular files cannot be opened or truncated. Attempts to do so will fail with `ENOKEY`. This implies that any regular file operations that require a file descriptor, such as `read()`, `write()`, `mmap()`, `fallocate()`, and `ioctl()`, are also forbidden.

Also without the key, files of any type (including directories) cannot be created or linked into an encrypted directory, nor can a name in an encrypted directory be the source or target of a rename, nor can an `O_TMPFILE` temporary file be created in an encrypted directory. All such operations will fail with `ENOKEY`.

It is not currently possible to backup and restore encrypted files without the encryption key. This would require special APIs which have not yet been implemented.

- **Encryption policy enforcement**

After an encryption policy has been set on a directory, all regular files, directories, and symbolic links created in that directory (recursively) will inherit that encryption policy. Special files --- that is, named pipes, device nodes, and UNIX domain sockets --- will not be encrypted.

Except for those special files, it is forbidden to have unencrypted files, or files encrypted with a different encryption policy, in an encrypted directory tree.

30.5.2. Client-side encryption key hierarchy

Each encrypted directory tree is protected by a master key.

To "unlock" an encrypted directory tree, userspace must provide the appropriate master key. There can be any number of master keys, each of which protects any number of directory trees on any number of filesystems.

30.5.3. Client-side encryption modes and usage

`fsencrypt` allows one encryption mode to be specified for file contents and one encryption mode to be specified for filenames. Different directory trees are permitted to use different encryption modes. Currently, the following pairs of encryption modes are supported:

- AES-256-XTS for contents and AES-256-CTS-CBC for filenames
- AES-128-CBC for contents and AES-128-CTS-CBC for filenames

If unsure, you should use the (AES-256-XTS, AES-256-CTS-CBC) pair.

Warning

In Lustre 2.14, client-side encryption only supports content encryption, and not filename encryption. As a consequence, only content encryption mode will be taken into account, and filename encryption mode will be ignored to leave filenames in clear text.

Warning

Introduced in Lustre 2.15

When Lustre client is built against the embedded kernel library instead of the in-kernel `fsencrypt`, the ability to encrypt file and directory names is governed by new `llite` parameter named `enable_filename_encryption`, introduced in 2.15, and set to 0 by default. When this parameter is 0, new empty directories configured as encrypted use content encryption only, and not name encryption. This mode is inherited for all subdirectories and files. When `enable_filename_encryption` parameter is set to 1, new empty directories configured as encrypted use full encryption capabilities by encrypting file content and also file and directory names. This mode is inherited for all subdirectories and files. To set the `enable_filename_encryption` parameter globally for all clients, one can do on the MGS:

```
mgs# lctl set_param -P llite.*.enable_filename_encryption=1
```

Be aware that the `enable_filename_encryption` tuning parameter is not available when Lustre client is built against in-kernel `fsencrypt`. Indeed, the in-kernel `fsencrypt` library always encrypts file name along with file content.

Also note that new files and directories under a parent encrypted directory created with Lustre 2.14 will not have their names encrypted. Also, because files created with Lustre 2.14 did not have their names encrypted, they will remain so after upgrade to 2.15. To benefit from name encryption for an old directory previously created with Lustre 2.14, you need to do the following after upgrade to 2.15 is complete:

1. create a new encrypted directory. This can use an already existing protector.
2. unlock the old encrypted directory.
3. copy all files and directories recursively from the old encrypted directory to the newly created encrypted directory. Note that this operation will re-encrypt all files contents in addition to names.
4. remove the old encrypted directory.

30.5.4. Client-side encryption threat model

- **Offline attacks**

For the Lustre case, block devices are Lustre targets attached to the Lustre servers. Manipulating the filesystem offline means accessing the filesystem on these targets while Lustre is offline.

Provided that a strong encryption key is chosen, `fsencrypt` protects the confidentiality of file contents in the event of a single point-in-time permanent offline compromise of the block device content. Lustre client-side encryption does not protect the confidentiality of metadata, e.g. file names, file sizes, file permissions, file timestamps, and extended attributes. Also, the existence and location of holes (unallocated blocks which logically contain all zeroes) in files is not protected.

- **Online attacks**

- On Lustre client

After an encryption key has been added, `fsencrypt` does not hide the plaintext file contents or filenames from other users on the same node. Instead, existing access control mechanisms such as file mode bits, POSIX ACLs, LSMs, or namespaces should be used for this purpose.

For the Lustre case, it means plaintext file contents or filenames are not hidden from other users on the same Lustre client.

An attacker who compromises the system enough to read from arbitrary memory, e.g. by exploiting a kernel security vulnerability, can compromise all encryption keys that are currently in use. However, `fsencrypt` allows encryption keys to be removed from the kernel, which may protect them from later compromise. Key removal can be carried out by non-root users. In more detail, the key removal will wipe the master encryption key from kernel memory. Moreover, it will try to evict all cached inodes which had been "unlocked" using the key, thereby wiping their per-file keys and making them once again appear "locked", i.e. in ciphertext or encrypted form.

- On Lustre server

An attacker on a Lustre server who compromises the system enough to read arbitrary memory, e.g. by exploiting a kernel security vulnerability, cannot compromise Lustre files content. Indeed, encryption keys are not forwarded to the Lustre servers, and servers do not carry out decryption or

encryption. Moreover, bulk RPCs received by servers contain encrypted data, which is written as-is to the underlying filesystem.

30.5.5. Manage encryption on directories

By default, Lustre client-side encryption is enabled, letting users define encryption policies on a per-directory basis.

Note

Administrators can decide to prevent a Lustre client mount-point from using encryption by specifying the `noencrypt` client mount option. This can be also enforced from server side thanks to the `forbid_encryption` property on `nodemaps`. See Section 28.3, “Altering Properties” for how to manage `nodemaps`.

`fsencrypt` userspace tool can be used to manage encryption policies. See <https://github.com/google/fsencrypt> for comprehensive explanations. Below are examples on how to use this tool with Lustre. If not told otherwise, commands must be run on Lustre client side.

- Two preliminary steps are required before actually deciding which directories to encrypt, and this is the only functionality which requires root privileges. Administrator has to run:

```
# fsencrypt setup
Customizing passphrase hashing difficulty for this system...
Created global config file at "/etc/fsencrypt.conf".
Metadata directories created at "./.fsencrypt".
```

This first command has to be run on all clients that want to use encryption, as it sets up global `fsencrypt` parameters outside of Lustre.

```
# fsencrypt setup /mnt/lustre
Metadata directories created at "/mnt/lustre/.fsencrypt"
```

This second command has to be run on just one Lustre client.

Note

The file `/etc/fsencrypt.conf` can be edited. It is strongly recommended to set `policy_version` to 2, so that `fsencrypt` wipes files from memory when the encryption key is removed.

- Now a regular user is able to select a directory to encrypt:

```
$ fsencrypt encrypt /mnt/lustre/vault
The following protector sources are available:
1 - Your login passphrase (pam_passphrase)
2 - A custom passphrase (custom_passphrase)
3 - A raw 256-bit key (raw_key)
Enter the source number for the new protector [2 - custom_passphrase]: 2
Enter a name for the new protector: shield
Enter custom passphrase for protector "shield":
Confirm passphrase:
"/mnt/lustre/vault" is now encrypted, unlocked, and ready for use.
```

Starting from here, all files and directories created under `/mnt/lustre/vault` will be encrypted, according to the policy defined at the previous step.

Note

The encryption policy is inherited by all subdirectories. It is not possible to change the policy for a subdirectory.

- Another user can decide to encrypt a different directory with its own protector:

```
$ fscrypt encrypt /mnt/lustre/private
Should we create a new protector? [y/N] Y
The following protector sources are available:
1 - Your login passphrase (pam_passphrase)
2 - A custom passphrase (custom_passphrase)
3 - A raw 256-bit key (raw_key)
Enter the source number for the new protector [2 - custom_passphrase]: 2
Enter a name for the new protector: armor
Enter custom passphrase for protector "armor":
Confirm passphrase:
"/mnt/lustre/private" is now encrypted, unlocked, and ready for use.
```

- Users can decide to lock an encrypted directory at any time:

```
$ fscrypt lock /mnt/lustre/vault
"/mnt/lustre/vault" is now locked.
```

This action prevents access to encrypted content, and by removing the key from memory, it also wipes files from memory if they are not still open.

- Users regain access to the encrypted directory with the command:

```
$ fscrypt unlock /mnt/lustre/vault
Enter custom passphrase for protector "shield":
"/mnt/lustre/vault" is now unlocked and ready for use.
```

- Actually, `fscrypt` does not give direct access to master keys, but to protectors that are used to encrypt them. This mechanism gives the ability to change a passphrase:

```
$ fscrypt status /mnt/lustre
lustre filesystem "/mnt/lustre" has 2 protectors and 2 policies
```

PROTECTOR	LINKED	DESCRIPTION
deacab807bf0e788	No	custom protector "shield"
e691ae7a1990fc2a	No	custom protector "armor"

POLICY	UNLOCKED	PROTECTORS
52b2b5aff0e59d8e0d58f962e715862e	No	deacab807bf0e788
374e8944e4294b527e50363d86fc9411	No	e691ae7a1990fc2a

```
$ fscrypt metadata change-passphrase --protector=/mnt/lustre:deacab807bf0e788
Enter old custom passphrase for protector "shield":
Enter new custom passphrase for protector "shield":
Confirm passphrase:
Passphrase for protector deacab807bf0e788 successfully changed.
```

It makes also possible to have multiple protectors for the same policy. This is really useful when several users share an encrypted directory, because it avoids the need to share any secret between them.

```
$ fscrypt status /mnt/lustre/vault
"/mnt/lustre/vault" is encrypted with fscrypt.

Policy: 52b2b5aff0e59d8e0d58f962e715862e
Options: padding:32 contents:AES_256_XTS filenames:AES_256_CTS policy_version:2
Unlocked: No

Protected with 1 protector:
PROTECTOR      LINKED  DESCRIPTION
deacab807bf0e788  No      custom protector "shield"

$ fscrypt metadata create protector /mnt/lustre
Create new protector on "/mnt/lustre" [Y/n] Y
The following protector sources are available:
1 - Your login passphrase (pam_passphrase)
2 - A custom passphrase (custom_passphrase)
3 - A raw 256-bit key (raw_key)
Enter the source number for the new protector [2 - custom_passphrase]: 2
Enter a name for the new protector: bunker
Enter custom passphrase for protector "bunker":
Confirm passphrase:
Protector f3cclb5cf9b8f41c created on filesystem "/mnt/lustre".

$ fscrypt metadata add-protector-to-policy
--protector=/mnt/lustre:f3cclb5cf9b8f41c
--policy=/mnt/lustre:52b2b5aff0e59d8e0d58f962e715862e
WARNING: All files using this policy will be accessible with this protector!!
Protect policy 52b2b5aff0e59d8e0d58f962e715862e with protector f3cclb5cf9b8f41c?
Enter custom passphrase for protector "bunker":
Enter custom passphrase for protector "shield":
Protector f3cclb5cf9b8f41c now protecting policy 52b2b5aff0e59d8e0d58f962e715862e

$ fscrypt status /mnt/lustre/vault
"/mnt/lustre/vault" is encrypted with fscrypt.

Policy: 52b2b5aff0e59d8e0d58f962e715862e
Options: padding:32 contents:AES_256_XTS filenames:AES_256_CTS policy_version:2
Unlocked: No

Protected with 2 protectors:
PROTECTOR      LINKED  DESCRIPTION
deacab807bf0e788  No      custom protector "shield"
f3cclb5cf9b8f41c  No      custom protector "bunker"
```

30.6. Configuring Kerberos (KRB) Security

This chapter describes how to use Kerberos with Lustre.

30.6.1. What Is Kerberos?

Kerberos is a mechanism for authenticating all entities (such as users and servers) on an "unsafe" network. Each of these entities, known as "principals", negotiate a runtime key with the Kerberos server. This key enables principals to verify that messages from the Kerberos server are authentic. By trusting the Kerberos server, users and services can authenticate one another.

Setting up Lustre with Kerberos can provide advanced security protections for the Lustre network. Broadly, Kerberos offers three types of benefit:

- Allows Lustre connection peers (MDS, OSS and clients) to authenticate one another.
- Protects the integrity of PTLRPC messages from being modified during network transfer.
- Protects the privacy of the PTLRPC message from being eavesdropped during network transfer.

Kerberos uses the “kernel keyring” client upcall mechanism.

30.6.2. Security Flavor

A security flavor is a string to describe what kind authentication and data transformation be performed upon a PTLRPC connection. It covers both RPC message and BULK data.

The supported flavors are described in following table:

Base Flavor	Authentication	RPC Message Protection	Bulk Data Protection	Notes
<i>null</i>	N/A	N/A	N/A	
<i>krb5n</i>	GSS/Kerberos5	null	checksum	No protection of RPC message, checksum protection of bulk data, light performance overhead.
<i>krb5a</i>	GSS/Kerberos5	partial integrity (krb5)	checksum	Only header of RPC message is integrity protected, and checksum protection of bulk data, more performance overhead compare to <i>krb5n</i> .
<i>krb5i</i>	GSS/Kerberos5	integrity (krb5)	integrity (krb5)	transformation algorithm is determined by actual Kerberos algorithms enforced by KDC and principals; heavy performance penalty.

Base Flavor	Authentication	RPC Message Protection	Bulk Data Protection	Notes
<i>krb5p</i>	GSS/Kerberos5	privacy (krb5)	privacy (krb5)	transformation privacy protection algorithm is determined by actual Kerberos algorithms enforced by KDC and principals; the heaviest performance penalty.

30.6.3. Kerberos Setup

30.6.3.1. Distribution

We only support MIT Kerberos 5, from version 1.3.

For environmental requirements in general, and clock synchronization in particular, please refer to section Section 8.1.2, “Environmental Requirements”.

30.6.3.2. Principals Configuration

- Configure client nodes:

- For each client node, create a `lustre_root` principal and generate keytab.

```
kadmin> addprinc -randkey lustre_root/client_host.domain@REALM
```

```
kadmin> ktadd lustre_root/client_host.domain@REALM
```

- Install the keytab on the client node.

- Configure MGS nodes:

- For each MGS node, create a `lustre_mgs` principal and generate keytab.

```
kadmin> addprinc -randkey lustre_mgs/mgs_host.domain@REALM
```

```
kadmin> ktadd lustre_mds/mgs_host.domain@REALM
```

- Install the keytab on the MGS nodes.

- Configure MDS nodes:

- For each MDS node, create a `lustre_mds` principal and generate keytab.

```
kadmin> addprinc -randkey lustre_mds/mds_host.domain@REALM
```

```
kadmin> ktadd lustre_mds/mds_host.domain@REALM
```

- Install the keytab on the MDS nodes.

- Configure OSS nodes:

- For each OSS node, create a `lustre_oss` principal and generate keytab.

```
kadmin> addprinc -randkey lustre_oss/oss_host.domain@REALM
```

```
kadmin> ktadd lustre_oss/oss_host.domain@REALM
```

- Install the keytab on the client node.

Note

- The *host.domain* should be the FQDN in your network, otherwise server might not recognize any GSS request.
- As an alternative for the client keytab, if you want to save the trouble of assigning unique keytab for each client node, you can create a general `lustre_root` principal and its keytab, and install the same keytab on as many client nodes as you want. **Be aware that in this way one compromised client means all clients are insecure.**

```
kadmin> addprinc -randkey lustre_root@REALM
```

```
kadmin> ktadd lustre_root@REALM
```

- Lustre support following *enctypes* for MIT Kerberos 5 version 1.3 or higher:
 - *aes128-cts*
 - *aes256-cts*

30.6.4. Networking

On networks for which name resolution to IP address is possible, like TCP or InfiniBand, the names used in the principals must be the ones that resolve to the IP addresses used by the Lustre NIDs.

If you are using a network which is **NOT** TCP or InfiniBand (e.g. PTL4LND), you need to have a `/etc/lustre/nid2hostname` script on **each** node, which purpose is to translate NID into hostname. Following is a possible example for PTL4LND:

```
#!/bin/bash
set -x

# convert a NID for a LND to a hostname

# called with thre arguments: lnd netid nid
# $lnd is the string "PTL4LND", etc.
# $netid is the network identifier in hex string format
# $nid is the NID in hex format
# output the corresponding hostname,
# or error message leaded by a '@' for error logging.

lnd=$1
netid=$2
# convert hex NID number to decimal
nid=$((0x$3))
```

```
case $lnd in
    PTL4LND) # simply add 'node' at the beginning
        echo "node${nid}"
        ;;
    *)
        echo "@unknown LND: $lnd"
        ;;
esac
```

30.6.5. Required packages

Every node should have following packages installed:

- krb5-workstation
- krb5-libs
- keyutils
- keyutils-libs

On the node used to build Lustre with GSS support, following packages should be installed:

- krb5-devel
- keyutils-libs-devel

30.6.6. Build Lustre

Enable GSS at configuration time:

```
./configure --enable-gss --other-options
```

30.6.7. Running

30.6.7.1. GSS Daemons

Make sure to start the daemon process `lsvcgssd` on each server node (MGS, MDS and OSS) before starting Lustre. The command syntax is:

```
lsvcgssd [-f] [-v] [-g] [-m] [-o] -k
```

- -f: run in foreground, instead of as daemon
- -v: increase verbosity by 1. For example, to set the verbose level to 3, run `lsvcgssd -vvv`. Verbose logging can help you make sure Kerberos is set up correctly.
- -g: service MGS
- -m: service MDS
- -o: service OSS
- -k: enable kerberos support

30.6.7.2. Setting Security Flavors

Security flavors can be set by defining `sptlrpc` rules on the MGS. These rules are persistent, and are in the form: `<spec>=<flavor>`

- To add a rule:

```
mgs> lctl conf_param <spec>=<flavor>
```

If there is an existing rule on `<spec>`, it will be overwritten.

- To delete a rule:

```
mgs> lctl conf_param -d <spec>
```

- To list existing rules:

```
msg> lctl get_param mgs.MGS.live.<fs-name> | grep "srpc.flavor"
```

Note

- If nothing is specified, by default all RPC connections will use `null` flavor, which means no security.
- After you change a rule, it usually takes a few minutes to apply the new rule to all nodes, depending on global system load.
- Before you change a rule, make sure affected nodes are ready for the new security flavor. E.g. if you change flavor from `null` to `krb5p` but GSS/Kerberos environment is not properly configured on affected nodes, those nodes might be evicted because they cannot communicate with each other.

30.6.7.3. Rules Syntax & Examples

The general syntax is: `<target>.srpc.flavor.<network>[.<direction>]=flavor`

- `<target>` can be filesystem name, or specific MDT/OST device name. For example `testfs`, `testfs-MDT0000`, `testfs-OST0001`.
- `<network>` is the LNet network name, for example `tcp0`, `o2ib0`, or `default` to not filter on LNet network.
- `<direction>` can be one of `cli2mdt`, `cli2ost`, `mdt2mdt`, `mdt2ost`. Direction is optional.

Examples:

- Apply `krb5i` on **ALL** connections for file system `testfs`:

```
mgs> lctl conf_param testfs.srpc.flavor.default=krb5i
```

- Nodes in network `tcp0` use `krb5p`; all other nodes use `null`.

```
mgs> lctl conf_param testfs.srpc.flavor.tcp0=krb5p  
mgs> lctl conf_param testfs.srpc.flavor.default=null
```

- Nodes in network `tcp0` use `krb5p`; nodes in `o2ib0` use `krb5n`; among other nodes, clients use `krb5i` to MDT/OST, MDTs use `null` to other MDTs, MDTs use `krb5a` to OSTs.

```
mgs> lctl conf_param testfs.srpc.flavor.tcp0=krb5p
mgs> lctl conf_param testfs.srpc.flavor.o2ib0=krb5n
mgs> lctl conf_param testfs.srpc.flavor.default.cli2mdt=krb5i
mgs> lctl conf_param testfs.srpc.flavor.default.cli2ost=krb5i
mgs> lctl conf_param testfs.srpc.flavor.default.mdt2mdt=null
mgs> lctl conf_param testfs.srpc.flavor.default.mdt2ost=krb5a
```

30.6.7.4. Regular Users Authentication

On client nodes, non-root users need to issue `kinit` before accessing Lustre, just like other Kerberized applications.

- Required by kerberos, the user's principal (`username@REALM`) should be added to the KDC.
- Client and MDT nodes should have the same user database used for name and uid/gid translation.

Regular users can destroy the established security contexts before logging out, by issuing:

```
lfs flushctx -k -r <mount point>
```

Here `-k` is to destroy the on-disk Kerberos credential cache, similar to `kdestroy`, and `-r` is to reap the revoked keys from the keyring when flushing the GSS context. Otherwise it only destroys established contexts in kernel memory.

30.6.8. Secure MGS connection

Each node can specify which flavor to use to connect to the MGS, by using the `mgssec=flavor` mount option. Once a flavor is chosen, it cannot be changed until re-mount.

Because a Lustre node only has one connection to the MGS, if there is more than one target or client on the node, they necessarily use the same security flavor to the MGS, being the one enforced when the first connection to the MGS was established.

By default, the MGS accepts RPCs with any flavor. But it is possible to configure the MGS to only accept a given flavor. The syntax is identical to what is explained in paragraph Section 30.6.7.3, “Rules Syntax & Examples”, but with special target `_mgs`:

```
mgs> lctl conf_param _mgs.srpc.flavor.<network>=<flavor>
```

Chapter 31. Lustre ZFS Snapshots

This chapter describes the ZFS Snapshot feature support in Lustre and contains following sections:

- Section 31.1, “Introduction”
- Section 31.2, “Configuration ”
- Section 31.3, “Snapshot Operations”
- Section 31.4, “Global Write Barriers”
- Section 31.5, “Snapshot Logs”
- Section 31.6, “Lustre Configuration Logs”

31.1. Introduction

Snapshots provide fast recovery of files from a previously created checkpoint without recourse to an offline backup or remote replica. Snapshots also provide a means to version-control storage, and can be used to recover lost files or previous versions of files.

Filesystem snapshots are intended to be mounted on user-accessible nodes, such as login nodes, so that users can restore files (e.g. after accidental delete or overwrite) without administrator intervention. It would be possible to mount the snapshot filesystem(s) via automount when users access them, rather than mounting all snapshots, to reduce overhead on login nodes when the snapshots are not in use.

Recovery of lost files from a snapshot is usually considerably faster than from any offline backup or remote replica. However, note that snapshots do not improve storage reliability and are just as exposed to hardware failure as any other storage volume.

31.1.1. Requirements

All Lustre server targets must be ZFS file systems running Lustre version 2.10 or later. In addition, the MGS must be able to communicate via ssh or another remote access protocol, without password authentication, to all other servers.

The feature is enabled by default and cannot be disabled. The management of snapshots is done through `lctl` commands on the MGS.

Lustre snapshot is based on Copy-On-Write; the snapshot and file system may share a single copy of the data until a file is changed on the file system. The snapshot will prevent the space of deleted or overwritten files from being released until the snapshot(s) referencing those files is deleted. The file system administrator needs to establish a snapshot create/backup/remove policy according to their system’s actual size and usage.

31.2. Configuration

The snapshot tool loads system configuration from the `/etc/ldev.conf` file on the MGS and calls related ZFS commands to maintain the Lustre snapshot pieces on all targets (MGS/MDT/OST). Please note that the `/etc/ldev.conf` file is used for other purposes as well.

The format of the file is:

```
<host> foreign/- <label> <device> [journal-path]/- [raidtab]
```

The format of <label> is:

```
fsname-<role><index> or <role><index>
```

The format of <device> is:

```
[md|zfs:][pool_dir/]<pool>/<filesystem>
```

Snapshot only uses the fields <host>, <label> and <device>.

Example 1:

```
mgs# cat /etc/ldev.conf
host-mdt1 - myfs-MDT0000 zfs:/tmp/myfs-mdt1/mdt1
host-mdt2 - myfs-MDT0001 zfs:myfs-mdt2/mdt2
host-ost1 - OST0000 zfs:/tmp/myfs-ost1/ost1
host-ost2 - OST0001 zfs:myfs-ost2/ost2
```

Example 2:

For the given mounted MGS/OST on single node:

```
singlennode# mount | grep "lustre-[m|o]"
lustre-mdt1/mdt1 on /mnt/lustre-mds1 type lustre (rw,svname=lustre-MDT0000
lustre-ost1/ost1 on /mnt/lustre-ost1 type lustre (rw,svname=lustre-OST0000
```

The corresponding /etc/ldev.conf would be

```
singlennode# cat /etc/ldev.conf
centos79z1 - lustre-MDT0000 zfs:/tmp/lustre-mdt1/mdt1 - -
centos79z1 - lustre-OST0000 zfs:/tmp/lustre-ost1/ost1 - -
```

Where:

Fields	Description
centos79z1	Hostname
-	Not Used
lustre-OST0000	Device label
zfs:/tmp/lustre-ost1/ost1	Device Name
-	Not Used
-	Not Used

The configuration file is edited manually.

Once the configuration file is updated to reflect the current file system setup, you are ready to create a file system snapshot.

31.3. Snapshot Operations

31.3.1. Creating a Snapshot

To create a snapshot of an existing Lustre file system, run the following `lctl` command on the MGS:

```
lctl snapshot_create [-b | --barrier [on | off]] [-c | --comment
comment] -F | --fsname fsname> [-h | --help] -n | --name sname>
[-r | --rsh remote_shell][ -t | --timeout timeout]
```

Option	Description
-b	set write barrier before creating snapshot. The default value is 'on'.
-c	a description for the purpose of the snapshot
-F	the filesystem name
-h	help information
-n	the name of the snapshot
-r	the remote shell used for communication with remote target. The default value is 'ssh'
-t	the lifetime (seconds) for write barrier. The default value is 30 seconds

31.3.2. Delete a Snapshot

To delete an existing snapshot, run the following `lctl` command on the MGS:

```
lctl snapshot_destroy [-f | --force] <-F | --fsname fsname>
<-n | --name sname> [-r | --rsh remote_shell]
```

Option	Description
-f	destroy the snapshot by force
-F	the filesystem name
-h	help information
-n	the name of the snapshot
-r	the remote shell used for communication with remote target. The default value is 'ssh'

31.3.3. Mounting a Snapshot

Snapshots are treated as separate file systems and can be mounted on Lustre clients. The snapshot file system must be mounted as a read-only file system with the `-o ro` option. If the `mount` command does not include the read-only option, the mount will fail.

Note

Before a snapshot can be mounted on the client, the snapshot must first be mounted on the servers using the `lctl` utility.

To mount a snapshot on the server, run the following `lctl` command on the MGS:

```
lctl snapshot_mount <-F | --fsname fsname> [-h | --help]
<-n | --name ssname> [-r | --rsh remote_shell]
```

Option	Description
-F	the filesystem name
-h	help information
-n	the name of the snapshot
-r	the remote shell used for communication with remote target. The default value is 'ssh'

After the successful mounting of the snapshot on the server, clients can now mount the snapshot as a read-only filesystem. For example, to mount a snapshot named `snapshot_20170602` for a filesystem named `myfs`, the following mount command would be used:

```
mgs# lctl snapshot_mount -F myfs -n snapshot_20170602
```

After mounting on the server, use `lctl snapshot_list` to get the `fsname` for the snapshot itself as follows:

```
ss_fsname=$(lctl snapshot_list -F myfs -n snapshot_20170602 |
awk '/^snapshot_fsname/ { print $2 }')
```

Finally, mount the snapshot on the client:

```
mount -t lustre -o ro $MGS_nid:$ss_fsname $local_mount_point
```

31.3.4. Unmounting a Snapshot

To unmount a snapshot from the servers, first unmount the snapshot file system from all clients, using the standard `umount` command on each client. For example, to unmount the snapshot file system named `snapshot_20170602` run the following command on each client that has it mounted:

```
client# umount $local_mount_point
```

After all clients have unmounted the snapshot file system, run the following `lctl` command on a server node where the snapshot is mounted:

```
lctl snapshot_umount [-F | --fsname fsname] [-h | --help]
<-n | --name ssname> [-r | --rsh remote_shell]
```

Option	Description
-F	the filesystem name
-h	help information
-n	the name of the snapshot
-r	the remote shell used for communication with remote target. The default value is 'ssh'

For example:

```
lctl snapshot_umount -F myfs -n snapshot_20170602
```

31.3.5. List Snapshots

To list the available snapshots for a given file system, use the following `lctl` command on the MGS:

```
lctl snapshot_list [-d | --detail] <-F | --fsname fsname>
[-h | -- help] [-n | --name sname] [-r | --rsh remote_shell]
```

Option	Description
-d	list every piece for the specified snapshot
-F	the filesystem name
-h	help information
-n	the snapshot's name. If the snapshot name is not supplied, all snapshots for this file system will be displayed
-r	the remote shell used for communication with remote target. The default value is 'ssh'

31.3.6. Modify Snapshot Attributes

Currently, Lustre snapshot has five user visible attributes; snapshot name, snapshot comment, create time, modification time, and snapshot file system name. Among them, the former two attributes can be modified. Renaming follows the general ZFS snapshot name rules, such as the maximum length is 256 bytes, cannot conflict with the reserved names, and so on.

To modify a snapshot's attributes, use the following `lctl` command on the MGS:

```
lctl snapshot_modify [-c | --comment comment]
<-F | --fsname fsname> [-h | --help] <-n | --name sname>
[-N | --new new_sname] [-r | --rsh remote_shell]
```

Option	Description
-c	update the snapshot's comment
-F	the filesystem name
-h	help information
-n	the snapshot's name
-N	rename the snapshot's name as <i>new_sname</i>
-r	the remote shell used for communication with remote target. The default value is 'ssh'

31.4. Global Write Barriers

Snapshots are non-atomic across multiple MDTs and OSTs, which means that if there is activity on the file system while a snapshot is being taken, there may be user-visible namespace inconsistencies with files created or destroyed in the interval between the MDT and OST snapshots. In order to create a consistent snapshot of the file system, we are able to set a global

write barrier, or “freeze” the system. Once set, all metadata modifications will be blocked until the write barrier is actively removed (“thawed”) or expired. The user can set a timeout parameter on a global barrier or the barrier can be explicitly removed. The default timeout period is 30 seconds.

It is important to note that snapshots are usable without the global barrier. Only files that are currently being modified by clients (write, create, unlink) may be inconsistent as noted above if the barrier is not used. Other files not currently being modified would be usable even without the barrier.

The snapshot create command will call the write barrier internally when requested using the `-b` option to `lctl snapshot_create`. So, explicit use of the barrier is not required when using snapshots but included here as an option to quiet the file system before a snapshot is created.

31.4.1. Impose Barrier

To impose a global write barrier, run the `lctl barrier_freeze` command on the MGS:

```
lctl barrier_freeze <fsname> [timeout (in seconds)]  
where timeout default is 30.
```

For example, to freeze the filesystem `testfs` for 15 seconds:

```
mgs# lctl barrier_freeze testfs 15
```

If the command is successful, there will be no output from the command. Otherwise, an error message will be printed.

31.4.2. Remove Barrier

To remove a global write barrier, run the `lctl barrier_thaw` command on the MGS:

```
lctl barrier_thaw <fsname>
```

For example, to thaw the write barrier for the filesystem `testfs`:

```
mgs# lctl barrier_thaw testfs
```

If the command is successful, there will be no output from the command. Otherwise, an error message will be printed.

31.4.3. Query Barrier

To see how much time is left on a global write barrier, run the `lctl barrier_stat` command on the MGS:

```
# lctl barrier_stat <fsname>
```

For example, to stat the write barrier for the filesystem `testfs`:

```
mgs# lctl barrier_stat testfs  
The barrier for testfs is in 'frozen'  
The barrier will be expired after 7 seconds
```

If the command is successful, a status from the table below will be printed. Otherwise, an error message will be printed.

The possible status and related meanings for the write barrier are as follows:

Table 31.1. Write Barrier Status

Status	Meaning
init	barrier has never been set on the system
freezing_p1	In the first stage of setting the write barrier
freezing_p2	the second stage of setting the write barrier
frozen	the write barrier has been set successfully
thawing	In thawing the write barrier
thawed	The write barrier has been thawed
failed	Failed to set write barrier
expired	The write barrier is expired
rescan	In scanning the MDTs status, see the command <code>barrier_rescan</code>
unknown	Other cases

If the barrier is in 'freezing_p1', 'freezing_p2' or 'frozen' status, then the remaining lifetime will be returned also.

31.4.4. Rescan Barrier

To rescan a global write barrier to check which MDTs are active, run the `lctl barrier_rescan` command on the MGS:

```
lctl barrier_rescan <fsname> [timeout (in seconds)],
where the default timeout is 30 seconds.
```

For example, to rescan the barrier for filesystem `testfs`:

```
mgs# lctl barrier_rescan testfs
1 of 4 MDT(s) in the filesystem testfs are inactive
```

If the command is successful, the number of MDTs that are unavailable against the total MDTs will be reported. Otherwise, an error message will be printed.

31.5. Snapshot Logs

A log of all snapshot activity can be found in the following file: `/var/log/lsnapshot.log`. This file contains information on when a snapshot was created, an attribute was changed, when it was mounted, and other snapshot information.

The following is a sample `/var/log/lsnapshot` file:

```
Mon Mar 21 19:43:06 2016
(15826:jt_snapshot_create:1138:scratch:ssh): Create snapshot lss_0_0
successfully with comment <(null)>, barrier <enable>, timeout <30>
```

```
Mon Mar 21 19:43:11 2016(13030:jt_snapshot_create:1138:scratch:ssh):
Create snapshot lss_0_1 successfully with comment <(null)>, barrier
<disable>, timeout <-1>
Mon Mar 21 19:44:38 2016 (17161:jt_snapshot_mount:2013:scratch:ssh):
The snapshot lss_1a_0 is mounted
Mon Mar 21 19:44:46 2016
(17662:jt_snapshot_umount:2167:scratch:ssh): the snapshot lss_1a_0
have been umounted
Mon Mar 21 19:47:12 2016
(20897:jt_snapshot_destroy:1312:scratch:ssh): Destroy snapshot
lss_2_0 successfully with force <disable>
```

31.6. Lustre Configuration Logs

A snapshot is independent from the original file system that it is derived from and is treated as a new file system name that can be mounted by Lustre client nodes. The file system name is part of the configuration log names and exists in configuration log entries. Two commands exist to manipulate configuration logs: `lctl fork_lcfg` and `lctl erase_lcfg`.

The snapshot commands will use configuration log functionality internally when needed. So, use of the barrier is not required to use snapshots but included here as an option. The following configuration log commands are independent of snapshots and can be used independent of snapshot use.

To fork a configuration log, run the following `lctl` command on the MGS:

```
lctl fork_lcfg
```

Usage: `fork_lcfg <fsname> <newname>`

To erase a configuration log, run the following `lctl` command on the MGS:

```
lctl erase_lcfg
```

Usage: `erase_lcfg <fsname>`

Part IV. Tuning a Lustre File System for Performance

Part IV describes tools and procedures used to tune a Lustre file system for optimum performance. You will find information in this section about:

- Testing Lustre Network Performance (LNet Self-Test)
 - Benchmarking Lustre File System Performance (Lustre I/O Kit)
 - Tuning a Lustre File System
-

Table of Contents

32. Testing Lustre Network Performance (LNet Self-Test)	350
32.1. LNet Self-Test Overview	350
32.1.1. Prerequisites	351
32.2. Using LNet Self-Test	351
32.2.1. Creating a Session	351
32.2.2. Setting Up Groups	352
32.2.3. Defining and Running the Tests	352
32.2.4. Sample Script	353
32.3. LNet Self-Test Command Reference	354
32.3.1. Session Commands	354
32.3.2. Group Commands	355
32.3.3. Batch and Test Commands	357
32.3.4. Other Commands	360
33. Benchmarking Lustre File System Performance (Lustre I/O Kit)	363
33.1. Using Lustre I/O Kit Tools	363
33.1.1. Contents of the Lustre I/O Kit	363
33.1.2. Preparing to Use the Lustre I/O Kit	363
33.2. Testing I/O Performance of Raw Hardware (<code>sgpdd-survey</code>)	364
33.2.1. Tuning Linux Storage Devices	365
33.2.2. Running <code>sgpdd-survey</code>	365
33.3. Testing OST Performance (<code>obdfilter-survey</code>)	366
33.3.1. Testing Local Disk Performance	367
33.3.2. Testing Network Performance	369
33.3.3. Testing Remote Disk Performance	370
33.3.4. Output Files	371
33.4. Testing OST I/O Performance (<code>ost-survey</code>)	372
33.5. Testing MDS Performance (<code>mds-survey</code>)	373
33.5.1. Output Files	374
33.5.2. Script Output	374
33.6. Collecting Application Profiling Information (<code>stats-collect</code>)	375
33.6.1. Using <code>stats-collect</code>	375
34. Tuning a Lustre File System	377
34.1. Optimizing the Number of Service Threads	377
34.1.1. Specifying the OSS Service Thread Count	378
34.1.2. Specifying the MDS Service Thread Count	378
34.2. Binding MDS Service Thread to CPU Partitions	379
34.3. Tuning LNet Parameters	379
34.3.1. Transmit and Receive Buffer Size	379
34.3.2. Hardware Interrupts (<code>enable_irq_affinity</code>)	379
34.3.3. Binding Network Interface Against CPU Partitions	380
34.3.4. Network Interface Credits	380
34.3.5. Router Buffers	380
34.3.6. Portal Round-Robin	381
34.3.7. LNet Peer Health	382
34.4. <code>libcfs</code> Tuning	384
34.4.1. CPU Partition String Patterns	384
34.5. LND Tuning	385
34.5.1. <code>ko2ibln</code> Tuning	385
34.6. Network Request Scheduler (NRS) Tuning	387
34.6.1. First In, First Out (FIFO) policy	390
34.6.2. Client Round-Robin over NIDs (CRR-N) policy	390

34.6.3. Object-based Round-Robin (ORR) policy	391
34.6.4. Target-based Round-Robin (TRR) policy	394
34.6.5. Token Bucket Filter (TBF) policy	L 2.6 394
34.6.6. Delay policy	L 2.10 401
34.7. Lockless I/O Tunables	403
34.8. Server-Side Advice and Hinting	L 2.9 404
34.8.1. Overview	404
34.8.2. Examples	405
34.9. Large Bulk IO (16MB RPC)	L 2.9 406
34.9.1. Overview	406
34.9.2. Usage	406
34.10. Improving Lustre I/O Performance for Small Files	407
34.11. Understanding Why Write Performance is Better Than Read Performance	407

Chapter 32. Testing Lustre Network Performance (LNet Self-Test)

This chapter describes the LNet self-test, which is used by site administrators to confirm that Lustre Networking (LNet) has been properly installed and configured, and that underlying network software and hardware are performing according to expectations. The chapter includes:

- Section 32.1, “LNet Self-Test Overview”
- Section 32.2, “Using LNet Self-Test”
- Section 32.3, “LNet Self-Test Command Reference”

32.1. LNet Self-Test Overview

LNet self-test is a kernel module that runs over LNet and the Lustre network drivers (LNDs). It is designed to:

- Test the connection ability of the Lustre network
- Run regression tests of the Lustre network
- Test performance of the Lustre network

After you have obtained performance results for your Lustre network, refer to Chapter 34, *Tuning a Lustre File System* for information about parameters that can be used to tune LNet for optimum performance.

Note

Apart from the performance impact, LNet self-test is invisible to the Lustre file system.

An LNet self-test cluster includes two types of nodes:

- **Console node** - A node used to control and monitor an LNet self-test cluster. The console node serves as the user interface of the LNet self-test system and can be any node in the test cluster. All self-test commands are entered from the console node. From the console node, a user can control and monitor the status of the entire LNet self-test cluster (session). The console node is exclusive in that a user cannot control two different sessions from one console node.
- **Test nodes** - The nodes on which the tests are run. Test nodes are controlled by the user from the console node; the user does not need to log into them directly.

LNet self-test has two user utilities:

- **lst** - The user interface for the self-test console (run on the *console node*). It provides a list of commands to control the entire test system, including commands to create a session, create test groups, etc.
- **lstclient** - The userspace LNet self-test program (run on a *test node*). The `lstclient` utility is linked with userspace LNDs and LNet. This utility is not needed if only kernel space LNet and LNDs are used.

Note

Test nodes can be in either kernel or userspace. A *console node* can invite a kernel *test node* to join the session by running `lst add_group NID`, but the *console node* cannot actively add a userspace *test node* to the session. A *console node* can passively accept a *test node* to the session while the *test node* is running `lstclient` to connect to the *console node*.

32.1.1. Prerequisites

To run LNet self-test, these modules must be loaded on both *console nodes* and *test nodes*:

- `libcfs`
- `net`
- `lnet_selftest`
- `klnds`: A kernel Lustre network driver (LND) (i.e, `ksocklnd`, `ko2iblnd`...) as needed by your network configuration.

To load the required modules, run:

```
modprobe lnet_selftest
```

This command recursively loads the modules on which LNet self-test depends.

Note

While the *console node* and *test nodes* require all the prerequisite modules to be loaded, userspace *test nodes* do not require these modules.

32.2. Using LNet Self-Test

This section describes how to create and run an LNet self-test. The examples shown are for a test that simulates the traffic pattern of a set of Lustre servers on a TCP network accessed by Lustre clients on an InfiniBand network connected via LNet routers. In this example, half the clients are reading and half the clients are writing.

32.2.1. Creating a Session

A *session* is a set of processes that run on a *test node*. Only one session can be run at a time on a test node to ensure that the session has exclusive use of the node. The console node is used to create, change or destroy a session (`new_session`, `end_session`, `show_session`). For more about session parameters, see Section 32.3.1, “Session Commands”.

Almost all operations should be performed within the context of a session. From the *console node*, a user can only operate nodes in his own session. If a session ends, the session context in all test nodes is stopped.

The following commands set the `LST_SESSION` environment variable to identify the session on the console node and create a session called `read_write`:

```
export LST_SESSION=$$
```

```
lst new_session read_write
```

32.2.2. Setting Up Groups

A *group* is a named collection of nodes. Any number of groups can exist in a single LNet self-test session. Group membership is not restricted in that a *test node* can be included in any number of groups.

Each node in a group has a rank, determined by the order in which it was added to the group. The rank is used to establish test traffic patterns.

A user can only control nodes in his/her session. To allocate nodes to the session, the user needs to add nodes to a group (of the session). All nodes in a group can be referenced by the group name. A node can be allocated to multiple groups of a session.

In the following example, three groups are established on a console node:

```
lst add_group servers 192.168.10.[8,10,12-16]@tcp
lst add_group readers 192.168.1.[1-253/2]@o2ib
lst add_group writers 192.168.1.[2-254/2]@o2ib
```

These three groups include:

- Nodes that will function as 'servers' to be accessed by 'clients' during the LNet self-test session
- Nodes that will function as 'clients' that will simulate *reading* data from the 'servers'
- Nodes that will function as 'clients' that will simulate *writing* data to the 'servers'

Note

A *console node* can associate kernel space *test nodes* with the session by running `lst add_group NIDs`, but a userspace test node cannot be actively added to the session. A console node can passively "accept" a test node to associate with a test session while the test node running `lstclient` connects to the console node, i.e: `lstclient --sesid CONSOLE_NID --group NAME`).

32.2.3. Defining and Running the Tests

A *test* generates a network load between two groups of nodes, a source group identified using the `--from` parameter and a target group identified using the `--to` parameter. When a test is running, each node in the `--from group` simulates a client by sending requests to nodes in the `--to group`, which are simulating a set of servers, and then receives responses in return. This activity is designed to mimic Lustre file system RPC traffic.

A *batch* is a collection of tests that are started and stopped together and run in parallel. A test must always be run as part of a batch, even if it is just a single test. Users can only run or stop a test batch, not individual tests.

Tests in a batch are non-destructive to the file system, and can be run in a normal Lustre file system environment (provided the performance impact is acceptable).

A simple batch might contain a single test, for example, to determine whether the network bandwidth presents an I/O bottleneck. In this example, the `--to group` could be comprised of Lustre OSSs and `--from group` the compute nodes. A second test could be added to perform pings from a login node to the MDS to see how checkpointing affects the `ls -l` process.

Two types of tests are available:

- **ping** - A ping generates a short request message, which results in a short response. Pings are useful to determine latency and small message overhead and to simulate Lustre metadata traffic.
- **brw** - In a brw ('bulk read write') test, data is transferred from the target to the source (brwread) or data is transferred from the source to the target (brwwrite). The size of the bulk transfer is set using the size parameter. A brw test is useful to determine network bandwidth and to simulate Lustre I/O traffic.

In the example below, a batch is created called `bulk_rw`. Then two brw tests are added. In the first test, 1M of data is sent from the servers to the clients as a simulated read operation with a simple data validation check. In the second test, 4K of data is sent from the clients to the servers as a simulated write operation with a full data validation check.

```
lst add_batch bulk_rw
lst add_test --batch bulk_rw --from readers --to servers \
  brw read check=simple size=1M
lst add_test --batch bulk_rw --from writers --to servers \
  brw write check=full size=4K
```

The traffic pattern and test intensity is determined by several properties such as test type, distribution of test nodes, concurrency of test, and RDMA operation type. For more details, see Section 32.3.3, “Batch and Test Commands”.

32.2.4. Sample Script

This sample LNet self-test script simulates the traffic pattern of a set of Lustre servers on a TCP network, accessed by Lustre clients on an InfiniBand network (connected via LNet routers). In this example, half the clients are reading and half the clients are writing.

Run this script on the console node:

```
#!/bin/bash
export LST_SESSION=$$
lst new_session read/write
lst add_group servers 192.168.10.[8,10,12-16]@tcp
lst add_group readers 192.168.1.[1-253/2]@o2ib
lst add_group writers 192.168.1.[2-254/2]@o2ib
lst add_batch bulk_rw
lst add_test --batch bulk_rw --from readers --to servers \
brw read check=simple size=1M
lst add_test --batch bulk_rw --from writers --to servers \
brw write check=full size=4K
# start running
lst run bulk_rw
# display server stats for 30 seconds
lst stat servers & sleep 30; kill $!
# tear down
lst end_session
```

Note

This script can be easily adapted to pass the group NIDs by shell variables or command line arguments (making it good for general-purpose use).

32.3. LNet Self-Test Command Reference

The LNet self-test (`lst`) utility is used to issue LNet self-test commands. The `lst` utility takes a number of command line arguments. The first argument is the command name and subsequent arguments are command-specific.

32.3.1. Session Commands

This section describes `lst` session commands.

LST_FEATURES

The `lst` utility uses the `LST_FEATURES` environmental variable to determine what optional features should be enabled. All features are disabled by default. The supported values for `LST_FEATURES` are:

- **1** - Enable the Variable Page Size feature for LNet Selftest.

Example:

```
export LST_FEATURES=1
```

LST_SESSION

The `lst` utility uses the `LST_SESSION` environmental variable to identify the session locally on the self-test console node. This should be a numeric value that uniquely identifies all session processes on the node. It is convenient to set this to the process ID of the shell both for interactive use and in shell scripts. Almost all `lst` commands require `LST_SESSION` to be set.

Example:

```
export LST_SESSION=$$
```

```
new_session [--timeout SECONDS] [--force] SESSNAME
```

Creates a new session session named *SESSNAME*.

Parameter	Description
<code>--timeout <i>seconds</i></code>	Console timeout value of the session. The session ends automatically if it remains idle (i.e., no commands are issued) for this period.
<code>--force</code>	Ends conflicting sessions. This determines who 'wins' when one session conflicts with another. For example, if there is already an active session on this node, then the attempt to create a new session fails unless the <code>--force</code> flag is specified. If the <code>--force</code> flag is specified, then the active session is ended. Similarly, if a session attempts to add a node that is already 'owned' by another session, the <code>--force</code> flag allows this session to 'steal' the node.
<code><i>name</i></code>	A human-readable string to print when listing sessions or reporting session conflicts.

Example:

```
$ lst new_session --force read_write  
end_session
```

Stops all operations and tests in the current session and clears the session's status.

```
$ lst end_session  
show_session
```

Shows the session information. This command prints information about the current session. It does not require LST_SESSION to be defined in the process environment.

```
$ lst show_session
```

32.3.2. Group Commands

This section describes `lst` group commands.

```
add_group name NIDS [NIDS...]
```

Creates the group and adds a list of test nodes to the group.

Parameter	Description
<i>name</i>	Name of the group.
<i>NIDS</i>	A string that may be expanded to include one or more LNet NIDs.

Example:

```
$ lst add_group servers 192.168.10.[35,40-45]@tcp  
$ lst add_group clients 192.168.1.[10-100]@tcp 192.168.[2,4].\  
[10-20]@tcp
```

```
update_group name [--refresh] [--clean status] [--remove NIDS]
```

Updates the state of nodes in a group or adjusts a group's membership. This command is useful if some nodes have crashed and should be excluded from the group.

Parameter	Description	
<code>--refresh</code>	Refreshes the state of all inactive nodes in the group.	
<code>--clean status</code>	Removes nodes with a specified status from the group. Status may be:	
	active	The node is in the current session.
	busy	The node is now owned by another session.
	down	The node has been marked down.
	unknown	The node's status has yet to be determined.
	invalid	Any state but active.
<code>--remove NIDS</code>	Removes specified nodes from the group.	

Example:

```
$ lst update_group clients --refresh
$ lst update_group clients --clean busy
$ lst update_group clients --clean invalid // \
  invalid == busy || down || unknown
$ lst update_group clients --remove \192.168.1.[10-20]@tcp

list_group [name] [--active] [--busy] [--down] [--unknown] [--all]
```

Prints information about a group or lists all groups in the current session if no group is specified.

Parameter	Description
<i>name</i>	The name of the group.
--active	Lists the active nodes.
--busy	Lists the busy nodes.
--down	Lists the down nodes.
--unknown	Lists unknown nodes.
--all	Lists all nodes.

Example:

```
$ lst list_group
1) clients
2) servers
Total 2 groups
$ lst list_group clients
ACTIVE BUSY DOWN UNKNOWN TOTAL
3 1 2 0 6
$ lst list_group clients --all
192.168.1.10@tcp Active
192.168.1.11@tcp Active
192.168.1.12@tcp Busy
192.168.1.13@tcp Active
192.168.1.14@tcp DOWN
192.168.1.15@tcp DOWN
Total 6 nodes
$ lst list_group clients --busy
192.168.1.12@tcp Busy
Total 1 node
```

`del_group name`

Removes a group from the session. If the group is referred to by any test, then the operation fails. If nodes in the group are referred to only by this group, then they are kicked out from the current session; otherwise, they are still in the current session.

```
$ lst del_group clients
```

```
lstclient --sesid NID --group name [--server_mode]
```

Use `lstclient` to run the userland self-test client. The `lstclient` command should be executed after creating a session on the console. There are only two mandatory options for `lstclient`:

Parameter	Description
<code>--sesid <i>NID</i></code>	The first console's NID.
<code>--group <i>name</i></code>	The test group to join.
<code>--server_mode</code>	When included, forces LNet to behave as a server, such as starting an acceptor if the underlying NID needs it or using privileged ports. Only root is allowed to use the <code>--server_mode</code> option.

Example:

```
Console $ lst new_session testsession
Client1 $ lstclient --sesid 192.168.1.52@tcp --group clients
```

Example:

```
Client1 $ lstclient --sesid 192.168.1.52@tcp |--group clients --server_mode
```

32.3.3. Batch and Test Commands

This section describes `lst` batch and test commands.

`add_batch name`

A default batch test set named `batch` is created when the session is started. You can specify a batch name by using `add_batch`:

```
$ lst add_batch bulkperf
```

Creates a batch test called `bulkperf`.

```
add_test --batch batchname [--loop loop_count] [--concurrency active_count] [--dis
--from group --to group brw|ping test_options
```

Adds a test to a batch. The parameters are described below.

Parameter	Description
<code>--batch <i>batchname</i></code>	Names a group of tests for later execution.
<code>--loop <i>loop_count</i></code>	Number of times to run the test.
<code>--concurrency <i>active_count</i></code>	The number of requests that are active at one time.
<code>--distribute <i>source_count:sink_count</i></code>	Determines the ratio of client nodes to server nodes for the specified test. This allows you to specify a wide range of topologies, including one-to-one and all-to-all. Distribution divides the source group into subsets, which are paired with equivalent subsets from the target group so only nodes in matching subsets communicate.
<code>--from <i>group</i></code>	The source group (test client).
<code>--to <i>group</i></code>	The target group (test server).
<code>ping</code>	Sends a small request message, resulting in a small reply message. For more details, see Section 32.2.3, “Defining and Running the Tests”. <code>ping</code> does not have any additional options.

Parameter	Description	
brw	Sends a small request message followed by a bulk data transfer, resulting in a small reply message. Section 32.2.3, “Defining and Running the Tests”. Options are:	
	read write	Read or write. The default is read.
	size=bytes[<i>KM</i>]	I/O size in bytes, kilobytes, or Megabytes (i.e., size=1024, size=4K, size=1M). The default is 4 kilobytes.
	check=full simple	A data validation check (checksum of data). The default is that no check is done.

Examples showing use of the distribute parameter:

```

Clients: (C1, C2, C3, C4, C5, C6)
Server: (S1, S2, S3)
--distribute 1:1 (C1->S1), (C2->S2), (C3->S3), (C4->S1), (C5->S2),
\ (C6->S3) /* -> means test conversation */ --distribute 2:1 (C1,C2->S1), (C3,C4->S2),
--distribute 3:1 (C1,C2,C3->S1), (C4,C5,C6->S2), (NULL->S3)
--distribute 3:2 (C1,C2,C3->S1,S2), (C4,C5,C6->S3,S1)
--distribute 4:1 (C1,C2,C3,C4->S1), (C5,C6->S2), (NULL->S3)
--distribute 4:2 (C1,C2,C3,C4->S1,S2), (C5, C6->S3, S1)
--distribute 6:3 (C1,C2,C3,C4,C5,C6->S1,S2,S3)

```

The setting `--distribute 1:1` is the default setting where each source node communicates with one target node.

When the setting `--distribute 1: n` (where *n* is the size of the target group) is used, each source node communicates with every node in the target group.

Note that if there are more source nodes than target nodes, some source nodes may share the same target nodes. Also, if there are more target nodes than source nodes, some higher-ranked target nodes will be idle.

Example showing a brw test:

```

$ lst add_group clients 192.168.1.[10-17]@tcp
$ lst add_group servers 192.168.10.[100-103]@tcp
$ lst add_batch bulkperf
$ lst add_test --batch bulkperf --loop 100 --concurrency 4 \
  --distribute 4:2 --from clients brw WRITE size=16K

```

In the example above, a batch test called `bulkperf` that will do a 16 kbyte bulk write request. In this test, two groups of four clients (sources) write to each of four servers (targets) as shown below:

- 192.168.1.[10-13] will write to 192.168.10.[100,101]
- 192.168.1.[14-17] will write to 192.168.10.[102,103]

list_batch [name] [--test index] [--active] [--invalid] [--server|client]

Lists batches in the current session or lists client and server nodes in a batch or a test.

Testing Lustre Network
Performance (LNet Self-Test)

Parameter	Description	
<code>--test <i>index</i></code>	Lists tests in a batch. If no option is used, all tests in the batch are listed. If one of these options are used, only specified tests in the batch are listed:	
	<code>active</code>	Lists only active batch tests.
	<code>invalid</code>	Lists only invalid batch tests.
	<code>server client</code>	Lists client and server nodes in a batch test.

Example:

```
$ lst list_batchbulkperf
$ lst list_batch bulkperf
Batch: bulkperf Tests: 1 State: Idle
ACTIVE BUSY DOWN UNKNOWN TOTAL
client 8 0 0 0 8
server 4 0 0 0 4
Test 1(brw) (loop: 100, concurrency: 4)
ACTIVE BUSY DOWN UNKNOWN TOTAL
client 8 0 0 0 8
server 4 0 0 0 4
$ lst list_batch bulkperf --server --active
192.168.10.100@tcp Active
192.168.10.101@tcp Active
192.168.10.102@tcp Active
192.168.10.103@tcp Active
```

`run name`

Runs the batch.

```
$ lst run bulkperf
```

`stop name`

Stops the batch.

```
$ lst stop bulkperf
```

```
query name [--test index] [--timeout seconds] [--loop loopcount] [--  
delay seconds] [--all]
```

Queries the batch status.

Parameter	Description
<code>--test <i>index</i></code>	Only queries the specified test. The test index starts from 1.
<code>--timeout <i>seconds</i></code>	The timeout value to wait for RPC. The default is 5 seconds.
<code>--loop #</code>	The loop count of the query.
<code>--delay <i>seconds</i></code>	The interval of each query. The default is 5 seconds.

Parameter	Description
--all	The list status of all nodes in a batch or a test.

Example:

```
$ lst run bulkperf
$ lst query bulkperf --loop 5 --delay 3
Batch is running
Batch is running
Batch is running
Batch is running
Batch is running
$ lst query bulkperf --all
192.168.1.10@tcp Running
192.168.1.11@tcp Running
192.168.1.12@tcp Running
192.168.1.13@tcp Running
192.168.1.14@tcp Running
192.168.1.15@tcp Running
192.168.1.16@tcp Running
192.168.1.17@tcp Running
$ lst stop bulkperf
$ lst query bulkperf
Batch is idle
```

32.3.4. Other Commands

This section describes other `lst` commands.

```
ping [-session] [--group name] [--nodes NIDs] [--batch name] [--server]
 [--timeout seconds]
```

Sends a 'hello' query to the nodes.

Parameter	Description
--session	Pings all nodes in the current session.
--group <i>name</i>	Pings all nodes in a specified group.
--nodes <i>NIDs</i>	Pings all specified nodes.
--batch <i>name</i>	Pings all client nodes in a batch.
--server	Sends RPC to all server nodes instead of client nodes. This option is only used with --batch <i>name</i> .
--timeout <i>seconds</i>	The RPC timeout value.

Example:

```
# lst ping 192.168.10.[15-20]@tcp
192.168.1.15@tcp Active [session: liang id: 192.168.1.3@tcp]
192.168.1.16@tcp Active [session: liang id: 192.168.1.3@tcp]
192.168.1.17@tcp Active [session: liang id: 192.168.1.3@tcp]
192.168.1.18@tcp Busy [session: Isaac id: 192.168.10.10@tcp]
```

Testing Lustre Network
Performance (LNet Self-Test)

```
192.168.1.19@tcp Down [session: <NULL> id: LNET_NID_ANY]  
192.168.1.20@tcp Down [session: <NULL> id: LNET_NID_ANY]
```

```
stat [--bw] [--rate] [--read] [--write] [--max] [--min] [--avg] " " [--  
timeout seconds] [--delay seconds] group/NIDs [group/NIDs]
```

The collection performance and RPC statistics of one or more nodes.

Parameter	Description
--bw	Displays the bandwidth of the specified group/nodes.
--rate	Displays the rate of RPCs of the specified group/nodes.
--read	Displays the read statistics of the specified group/nodes.
--write	Displays the write statistics of the specified group/nodes.
--max	Displays the maximum value of the statistics.
--min	Displays the minimum value of the statistics.
--avg	Displays the average of the statistics.
--timeout <i>seconds</i>	The timeout of the statistics RPC. The default is 5 seconds.
--delay <i>seconds</i>	The interval of the statistics (in seconds).

Example:

```
$ lst run bulkperf  
$ lst stat clients  
[LNet Rates of clients]  
[W] Avg: 1108 RPC/s Min: 1060 RPC/s Max: 1155 RPC/s  
[R] Avg: 2215 RPC/s Min: 2121 RPC/s Max: 2310 RPC/s  
[LNet Bandwidth of clients]  
[W] Avg: 16.60 MB/s Min: 16.10 MB/s Max: 17.1 MB/s  
[R] Avg: 40.49 MB/s Min: 40.30 MB/s Max: 40.68 MB/s
```

Specifying a group name (*group*) causes statistics to be gathered for all nodes in a test group. For example:

```
$ lst stat servers
```

where servers is the name of a test group created by `lst add_group`

Specifying a *NID* range (*NIDs*) causes statistics to be gathered for selected nodes. For example:

```
$ lst stat 192.168.0.[1-100/2]@tcp
```

Only LNet performance statistics are available. By default, all statistics information is displayed. Users can specify additional information with these options.

```
show_error [--session] [group|NIDs]....
```

Lists the number of failed RPCs on test nodes.

Parameter	Description
<code>--session</code>	Lists errors in the current test session. With this option, historical RPC errors are not listed.

Example:

```
$ lst show_error client
sclients
12345-192.168.1.15@tcp: [Session: 1 brw errors, 0 ping errors] \
  [RPC: 20 errors, 0 dropped,
12345-192.168.1.16@tcp: [Session: 0 brw errors, 0 ping errors] \
  [RPC: 1 errors, 0 dropped, Total 2 error nodes in clients
$ lst show_error --session clients
clients
12345-192.168.1.15@tcp: [Session: 1 brw errors, 0 ping errors]
Total 1 error nodes in clients
```

Chapter 33. Benchmarking Lustre File System Performance (Lustre I/O Kit)

This chapter describes the Lustre I/O kit, a collection of I/O benchmarking tools for a Lustre cluster. It includes:

- Section 33.1, “ Using Lustre I/O Kit Tools”
- Section 33.2, “ Testing I/O Performance of Raw Hardware (`sgpdd-survey`) ”
- Section 33.3, “Testing OST Performance (`obdfilter-survey`) ”
- Section 33.4, “ Testing OST I/O Performance (`ost-survey`)”
- Section 33.5, “ Testing MDS Performance (`mds-survey`)”
- Section 33.6, “ Collecting Application Profiling Information (`stats-collect`)”

33.1. Using Lustre I/O Kit Tools

The tools in the Lustre I/O Kit are used to benchmark Lustre file system hardware and validate that it is working as expected before you install the Lustre software. It can also be used to validate the performance of the various hardware and software layers in the cluster and also to find and troubleshoot I/O issues.

Typically, performance is measured starting with single raw devices and then proceeding to groups of devices. Once raw performance has been established, other software layers are then added incrementally and tested.

33.1.1. Contents of the Lustre I/O Kit

The I/O kit contains three tests, each of which tests a progressively higher layer in the Lustre software stack:

- `sgpdd-survey` - Measure basic 'bare metal' performance of devices while bypassing the kernel block device layers, buffer cache, and file system.
- `obdfilter-survey` - Measure the performance of one or more OSTs directly on the OSS node or alternately over the network from a Lustre client.
- `ost-survey` - Performs I/O against OSTs individually to allow performance comparisons to detect if an OST is performing sub-optimally due to hardware issues.

Typically with these tests, a Lustre file system should deliver 85-90% of the raw device performance.

A utility `stats-collect` is also provided to collect application profiling information from Lustre clients and servers. See Section 33.6, “ Collecting Application Profiling Information (`stats-collect`)” for more information.

33.1.2. Preparing to Use the Lustre I/O Kit

The following prerequisites must be met to use the tests in the Lustre I/O kit:

- Password-free remote access to nodes in the system (provided by `ssh` or `rsh`).
- LNet self-test completed to test that Lustre networking has been properly installed and configured. See Chapter 32, *Testing Lustre Network Performance (LNet Self-Test)*.
- Lustre file system software installed.
- `sg3_utils` package providing the `sgp_dd` tool (`sg3_utils` is a separate RPM package available online using YUM).

Download the Lustre I/O kit (`lustre-iokit`) from:

<https://downloads.whamcloud.com/>

33.2. Testing I/O Performance of Raw Hardware (`sgpdd-survey`)

The `sgpdd-survey` tool is used to test bare metal I/O performance of the raw hardware, while bypassing as much of the kernel as possible. This survey may be used to characterize the performance of a SCSI device by simulating an OST serving multiple stripe files. The data gathered by this survey can help set expectations for the performance of a Lustre OST using this device.

The script uses `sgp_dd` to carry out raw sequential disk I/O. It runs with variable numbers of `sgp_dd` threads to show how performance varies with different request queue depths.

The script spawns variable numbers of `sgp_dd` instances, each reading or writing a separate area of the disk to demonstrate performance variance within a number of concurrent stripe files.

Several tips and insights for disk performance measurement are described below. Some of this information is specific to RAID arrays and/or the Linux RAID implementation.

- *Performance is limited by the slowest disk.*

Before creating a RAID array, benchmark all disks individually. We have frequently encountered situations where drive performance was not consistent for all devices in the array. Replace any disks that are significantly slower than the rest.

- *Disks and arrays are very sensitive to request size.*

To identify the optimal request size for a given disk, benchmark the disk with different record sizes ranging from 4 KB to 1 to 2 MB.

Caution

The `sgpdd-survey` script overwrites the device being tested, which results in the **LOSS OF ALL DATA** on that device. Exercise caution when selecting the device to be tested.

Note

Array performance with all LUNs loaded does not always match the performance of a single LUN when tested in isolation.

Prerequisites:

- `sgp_dd` tool in the `sg3_utils` package
- Lustre software is *NOT* required

The device(s) being tested must meet one of these two requirements:

- If the device is a SCSI device, it must appear in the output of `sg_map` (make sure the kernel module `sg` is loaded).
- If the device is a raw device, it must appear in the output of `raw -qa`.

Raw and SCSI devices cannot be mixed in the test specification.

Note

If you need to create raw devices to use the `sgpdd-survey` tool, note that raw device 0 cannot be used due to a bug in certain versions of the "raw" utility (including the version shipped with Red Hat Enterprise Linux 4U4.)

33.2.1. Tuning Linux Storage Devices

To get large I/O transfers (1 MB) to disk, it may be necessary to tune several kernel parameters as specified:

```
/sys/block/sdN/queue/max_sectors_kb = 4096
/sys/block/sdN/queue/max_phys_segments = 256
/proc/scsi/sg/allow_dio = 1
/sys/module/ib_srp/parameters/srp_sg_tablesize = 255
/sys/block/sdN/queue/scheduler
```

Note

Recommended schedulers are **deadline** and **noop**. The scheduler is set by default to **deadline**, unless it has already been set to **noop**.

33.2.2. Running `sgpdd-survey`

The `sgpdd-survey` script must be customized for the particular device being tested and for the location where the script saves its working and result files (by specifying the `{rslt}` variable). Customization variables are described at the beginning of the script.

When the `sgpdd-survey` script runs, it creates a number of working files and a pair of result files. The names of all the files created start with the prefix defined in the variable `{rslt}`. (The default value is `/tmp`.) The files include:

- File containing standard output data (same as `stdout`)

```
{rslt}_date_time.summary
```

- Temporary (`tmp`) files

```
{rslt}_date_time_*
```

- Collected `tmp` files for post-mortem

```
{rslt}_date_time.detail
```

The `stdout` and the `.summary` file will contain lines like this:

```
total_size 8388608K rsz 1024 thr 1 crg 1 180.45 MB/s 1 x 180.50 \  
= 180.50 MB/s
```

Each line corresponds to a run of the test. Each test run will have a different number of threads, record size, or number of regions.

- `total_size` - Size of file being tested in KBs (8 GB in above example).
- `rsz` - Record size in KBs (1 MB in above example).
- `thr` - Number of threads generating I/O (1 thread in above example).
- `crg` - Current regions, the number of disjoint areas on the disk to which I/O is being sent (1 region in above example, indicating that no seeking is done).
- `MB/s` - Aggregate bandwidth measured by dividing the total amount of data by the elapsed time (180.45 MB/s in the above example).
- `MB/s` - The remaining numbers show the number of regions X performance of the slowest disk as a sanity check on the aggregate bandwidth.

If there are so many threads that the `sgp_dd` script is unlikely to be able to allocate I/O buffers, then `ENOMEM` is printed in place of the aggregate bandwidth result.

If one or more `sgp_dd` instances do not successfully report a bandwidth number, then `FAILED` is printed in place of the aggregate bandwidth result.

33.3. Testing OST Performance (`obdfilter-survey`)

The `obdfilter-survey` script generates sequential I/O from varying numbers of threads and objects (files) to simulate the I/O patterns of a Lustre client.

The `obdfilter-survey` script can be run directly on the OSS node to measure the OST storage performance without any intervening network, or it can be run remotely on a Lustre client to measure the OST performance including network overhead.

The `obdfilter-survey` is used to characterize the performance of the following:

- **Local file system** - In this mode, the `obdfilter-survey` script exercises one or more instances of the `obdfilter` directly. The script may run on one or more OSS nodes, for example, when the OSSs are all attached to the same multi-ported disk subsystem.

Run the script using the `case=disk` parameter to run the test against all the local OSTs. The script automatically detects all local OSTs and includes them in the survey.

To run the test against only specific OSTs, run the script using the `targets=` parameter to list the OSTs to be tested explicitly. If some OSTs are on remote nodes, specify their hostnames in addition to the OST name (for example, `oss2:lustre-OST0004`).

All `obdfilter` instances are driven directly. The script automatically loads the `obdecho` module (if required) and creates one instance of `echo_client` for each `obdfilter` instance in order to generate I/O requests directly to the OST.

For more details, see Section 33.3.1, “Testing Local Disk Performance”.

- **Network** - In this mode, the Lustre client generates I/O requests over the network but these requests are not sent to the OST file system. The OSS node runs the obdecho server to receive the requests but discards them before they are sent to the disk.

Pass the parameters `case=network` and `targets=hostname/IP_of_server` to the script. For each network case, the script does the required setup.

For more details, see Section 33.3.2, “Testing Network Performance”

- **Remote file system over the network** - In this mode the `obdfilter-survey` script generates I/O from a Lustre client to a remote OSS to write the data to the file system.

To run the test against all the local OSCs, pass the parameter `case=netdisk` to the script. Alternately you can pass the `target=` parameter with one or more OSC devices (e.g., `lustre-OST0000-osc-ffff88007754bc00`) against which the tests are to be run.

For more details, see Section 33.3.3, “Testing Remote Disk Performance”.

Caution

The `obdfilter-survey` script is potentially destructive and there is a small risk data may be lost. To reduce this risk, `obdfilter-survey` should not be run on devices that contain data that needs to be preserved. Thus, the best time to run `obdfilter-survey` is before the Lustre file system is put into production. The reason `obdfilter-survey` may be safe to run on a production file system is because it creates objects with object sequence 2. Normal file system objects are typically created with object sequence 0.

Note

If the `obdfilter-survey` test is terminated before it completes, some small amount of space is leaked. you can either ignore it or reformat the file system.

Note

The `obdfilter-survey` script is *NOT* scalable beyond tens of OSTs since it is only intended to measure the I/O performance of individual storage subsystems, not the scalability of the entire system.

Note

The `obdfilter-survey` script must be customized, depending on the components under test and where the script's working files should be kept. Customization variables are described at the beginning of the `obdfilter-survey` script. In particular, pay attention to the listed maximum values listed for each parameter in the script.

33.3.1. Testing Local Disk Performance

The `obdfilter-survey` script can be run automatically or manually against a local disk. This script profiles the overall throughput of storage hardware, including the file system and RAID layers managing the storage, by sending workloads to the OSTs that vary in thread count, object count, and I/O size.

When the `obdfilter-survey` script is run, it provides information about the performance abilities of the storage hardware and shows the saturation points.

The `plot-obdfilter` script generates from the output of the `obdfilter-survey` a CSV file and parameters for importing into a spreadsheet or gnuplot to visualize the data.

To run the `obdfilter-survey` script, create a standard Lustre file system configuration; no special setup is needed.

To perform an automatic run:

1. Start the Lustre OSTs.

The Lustre OSTs should be mounted on the OSS node(s) to be tested. The Lustre client is not required to be mounted at this time.

2. Verify that the `obdecho` module is loaded. Run:

```
modprobe obdecho
```

3. Run the `obdfilter-survey` script with the parameter `case=disk`.

For example, to run a local test with up to two objects (`nobjhi`), up to two threads (`thrhi`), and 1024 MB transfer size (`size`):

```
$ nobjhi=2 thrhi=2 size=1024 case=disk shobdfilter-survey
```

4. Performance measurements for write, rewrite, read etc are provided below:

```
# example output
Fri Sep 25 11:14:03 EDT 2015 Obdfilter-survey for case=disk from hds1fnb6123
ost 10 sz 167772160K rsz 1024K obj 10 thr 10 write 10982.73 [ 601.97,2912.91
...
```

The file `./lustre-iokit/obdfilter-survey/README.obdfilter-survey` provides an explanation for the output as follows:

```
ost 10          is the total number of OSTs under test.
sz 167772160K   is the total amount of data read or written (in bytes).
rsz 1024K       is the record size (size of each echo_client I/O, in bytes).
obj 10          is the total number of objects over all OSTs
thr 10          is the total number of threads over all OSTs and objects
write          is the test name. If more tests have been specified they
                all appear on the same line.
10982.73        is the aggregate bandwidth over all OSTs measured by
                dividing the total number of MB by the elapsed time.
[601.97,2912.91] are the minimum and maximum instantaneous bandwidths seen on
                any individual OST.
```

Note that although the numbers of threads and objects are specified per-OST in the customization section of the script, results are reported aggregated over all OSTs.

To perform a manual run:

1. Start the Lustre OSTs.

The Lustre OSTs should be mounted on the OSS node(s) to be tested. The Lustre client is not required to be mounted at this time.

2. Verify that the `obdecho` module is loaded. Run:

```
modprobe obdecho
```

3. Determine the OST names.

On the OSS nodes to be tested, run the `lctl dl` command. The OST device names are listed in the fourth column of the output. For example:

```
$ lctl dl |grep obdfilter
0 UP obdfilter lustre-OST0001 lustre-OST0001_UUID 1159
2 UP obdfilter lustre-OST0002 lustre-OST0002_UUID 1159
...
```

4. List all OSTs you want to test.

Use the `targets=`parameter to list the OSTs separated by spaces. List the individual OSTs by name using the format `fsname-OSTnumber` (for example, `lustre-OST0001`). You do not have to specify an MDS or LOV.

5. Run the `obdfilter-survey` script with the `targets=`parameter.

For example, to run a local test with up to two objects (`nobjhi`), up to two threads (`thrhi`), and 1024 Mb (size) transfer size:

```
$ nobjhi=2 thrhi=2 size=1024 targets="lustre-OST0001 \
lustre-OST0002" sh obdfilter-survey
```

33.3.2. Testing Network Performance

The `obdfilter-survey` script can only be run automatically against a network; no manual test is provided.

To run the network test, a specific Lustre file system setup is needed. Make sure that these configuration requirements have been met.

To perform an automatic run:

1. Start the Lustre OSTs.

The Lustre OSTs should be mounted on the OSS node(s) to be tested. The Lustre client is not required to be mounted at this time.

2. Verify that the `obdecho` module is loaded. Run:

```
modprobe obdecho
```

3. Start `lctl` and check the device list, which must be empty. Run:

```
lctl dl
```

4. Run the `obdfilter-survey` script with the parameters `case=network` and `targets=hostname/ip_of_server`. For example:

```
$ nobjhi=2 thrhi=2 size=1024 targets="oss0 oss1" \
case=network sh obdfilter-survey
```

5. On the server side, view the statistics at:

```
lctl get_param obdecho.echo_srv.stats
```

where `echo_srv` is the obdecho server created by the script.

33.3.3. Testing Remote Disk Performance

The `obdfilter-survey` script can be run automatically or manually against a network disk. To run the network disk test, start with a standard Lustre configuration. No special setup is needed.

To perform an automatic run:

1. Start the Lustre OSTs.

The Lustre OSTs should be mounted on the OSS node(s) to be tested. The Lustre client is not required to be mounted at this time.

2. Verify that the obdecho module is loaded. Run:

```
modprobe obdecho
```

3. Run the `obdfilter-survey` script with the parameter `case=netdisk`. For example:

```
$ nobjhi=2 thrhi=2 size=1024 case=netdisk sh obdfilter-survey
```

To perform a manual run:

1. Start the Lustre OSTs.

The Lustre OSTs should be mounted on the OSS node(s) to be tested. The Lustre client is not required to be mounted at this time.

2. Verify that the obdecho module is loaded. Run:

```
modprobe obdecho
```

3. Determine the OSC names.

On the OSS nodes to be tested, run the `lctl dl` command. The OSC device names are listed in the fourth column of the output. For example:

```
$ lctl dl |grep obdfilter
3 UP osc lustre-OST0000-osc-ffff88007754bc00 \
    54b91eab-0ea9-1516-b571-5e6df349592e 5
4 UP osc lustre-OST0001-osc-ffff88007754bc00 \
    54b91eab-0ea9-1516-b571-5e6df349592e 5
...
```

4. List all OSCs you want to test.

Use the `targets=`parameter to list the OSCs separated by spaces. List the individual OSCs by name separated by spaces using the format `fsname-OST_name-osc-instance` (for example, `lustre-OST0000-osc-ffff88007754bc00`). You *do not have to specify an MDS or LOV*.

5. Run the `obdfilter-survey` script with the `targets=osc` and `case=netdisk`.

An example of a local test run with up to two objects (`nobjhi`), up to two threads (`thrhi`), and 1024 Mb (size) transfer size is shown below:

```
$ nobjhi=2 thrhi=2 size=1024 \  
targets="lustre-OST0000-osc-ffff88007754bc00 \  
lustre-OST0001-osc-ffff88007754bc00" sh obdfilter-survey
```

33.3.4. Output Files

When the `obdfilter-survey` script runs, it creates a number of working files and a pair of result files. All files start with the prefix defined in the variable `${rslt}`.

File	Description
<code>\${rslt}.summary</code>	Same as stdout
<code>\${rslt}.script_*</code>	Per-host test script files
<code>\${rslt}.detail_tmp*</code>	Per-OST result files
<code>\${rslt}.detail</code>	Collected result files for post-mortem

The `obdfilter-survey` script iterates over the given number of threads and objects performing the specified tests and checks that all test processes have completed successfully.

Note

The `obdfilter-survey` script may not clean up properly if it is aborted or if it encounters an unrecoverable error. In this case, a manual cleanup may be required, possibly including killing any running instances of `lctl` (local or remote), removing `echo_client` instances created by the script and unloading `obdecho`.

33.3.4.1. Script Output

The `.summary` file and `stdout` of the `obdfilter-survey` script contain lines like:

```
ost 8 sz 67108864K rsz 1024 obj 8 thr 8 write 613.54 [ 64.00, 82.00]
```

Where:

Parameter and value	Description
ost 8	Total number of OSTs being tested.
sz 67108864K	Total amount of data read or written (in KB).
rsz 1024	Record size (size of each <code>echo_client</code> I/O, in KB).
obj 8	Total number of objects over all OSTs.
thr 8	Total number of threads over all OSTs and objects.
write	Test name. If more tests have been specified, they all appear on the same line.
613.54	Aggregate bandwidth over all OSTs (measured by dividing the total number of MB by the elapsed time).
[64, 82.00]	Minimum and maximum instantaneous bandwidths on an individual OST.

Note

Although the numbers of threads and objects are specified per-OST in the customization section of the script, the reported results are aggregated over all OSTs.

33.3.4.2. Visualizing Results

It is useful to import the `obdfilter-survey` script summary data (it is fixed width) into Excel (or any graphing package) and graph the bandwidth versus the number of threads for varying numbers of concurrent regions. This shows how the OSS performs for a given number of concurrently-accessed objects (files) with varying numbers of I/Os in flight.

It is also useful to monitor and record average disk I/O sizes during each test using the 'disk io size' histogram in the file `lctl get_param obdfilter.*.brw_stats` (see Section 39.3.5, "Monitoring the OST Block I/O Stream" for details). These numbers help identify problems in the system when full-sized I/Os are not submitted to the underlying disk. This may be caused by problems in the device driver or Linux block layer.

The `plot-obdfilter` script included in the I/O toolkit is an example of processing output files to a .csv format and plotting a graph using `gnuplot`.

33.4. Testing OST I/O Performance (`ost-survey`)

The `ost-survey` tool is a shell script that uses `lfs setstripe` to perform I/O against a single OST. The script writes a file (currently using `dd`) to each OST in the Lustre file system, and compares read and write speeds. The `ost-survey` tool is used to detect anomalies between otherwise identical disk subsystems.

Note

We have frequently discovered wide performance variations across all LUNs in a cluster. This may be caused by faulty disks, RAID parity reconstruction during the test, or faulty network hardware.

To run the `ost-survey` script, supply a file size (in KB) and the Lustre file system mount point. For example, run:

```
$ ./ost-survey.sh -s 10 /mnt/lustre
```

Typical output is:

```
Number of Active OST devices : 4
Worst  Read OST indx: 2 speed: 2835.272725
Best   Read OST indx: 3 speed: 2872.889668
Read Average: 2852.508999 +/- 16.444792 MB/s
Worst  Write OST indx: 3 speed: 17.705545
Best   Write OST indx: 2 speed: 128.172576
Write Average: 95.437735 +/- 45.518117 MB/s
Ost#  Read(MB/s)  Write(MB/s)  Read-time  Write-time
-----
```

Benchmarking Lustre File System
Performance (Lustre I/O Kit)

0	2837.440	126.918	0.035	0.788
1	2864.433	108.954	0.035	0.918
2	2835.273	128.173	0.035	0.780
3	2872.890	17.706	0.035	5.648

33.5. Testing MDS Performance (`mgs-survey`)

The `mgs-survey` script tests the local metadata performance using the `echo_client` to drive the MDD layer of the MDS stack. It can be used with the following classes of operations:

- Open-create/mkdir/create
- Lookup/getattr/setxattr
- Delete/destroy
- Unlink/rmdir

These operations will be run by a variable number of concurrent threads and will test with the number of directories specified by the user. The run can be executed such that all threads operate in a single directory (`dir_count=1`) or in private/unique directory (`dir_count=x thrlo=x thrhi=x`).

The mdd instance is driven directly. The script automatically loads the `obdecho` module if required and creates instance of `echo_client`.

This script can also create OST objects by providing `stripe_count` greater than zero.

To perform a run:

1. Start the Lustre MDT.

The Lustre MDT should be mounted on the MDS node to be tested.

2. Start the Lustre OSTs (optional, only required when test with OST objects)

The Lustre OSTs should be mounted on the OSS node(s).

3. Run the `mgs-survey` script as explain below

The script must be customized according to the components under test and where it should keep its working files. Customization variables are described as followed:

- `thrlo` - threads to start testing. skipped if less than `dir_count`
- `thrhi` - maximum number of threads to test
- `targets` - MDT instance
- `file_count` - number of files per thread to test
- `dir_count` - total number of directories to test. Must be less than or equal to `thrhi`
- `stripe_count` - number stripe on OST objects
- `tests_str` - test operations. Must have at least "create" and "destroy"
- `start_number` - base number for each thread to prevent name collisions

- layer - MDS stack's layer to be tested

Run without OST objects creation:

Setup the Lustre MDS without OST mounted. Then invoke the `mds-survey` script

```
$ thrhi=64 file_count=200000 sh mds-survey
```

Run with OST objects creation:

Setup the Lustre MDS with at least one OST mounted. Then invoke the `mds-survey` script with `stripe_count` parameter

```
$ thrhi=64 file_count=200000 stripe_count=2 sh mds-survey
```

Note: a specific MDT instance can be specified using `targets` variable.

```
$ targets=lustre-MDT0000 thrhi=64 file_count=200000 stripe_count=2 sh mds-survey
```

33.5.1. Output Files

When the `mds-survey` script runs, it creates a number of working files and a pair of result files. All files start with the prefix defined in the variable `${rslt}`.

File	Description
<code>\${rslt}.summary</code>	Same as stdout
<code>\${rslt}.script_*</code>	Per-host test script files
<code>\${rslt}.detail_tmp*</code>	Per-mdt result files
<code>\${rslt}.detail</code>	Collected result files for post-mortem

The `mds-survey` script iterates over the given number of threads performing the specified tests and checks that all test processes have completed successfully.

Note

The `mds-survey` script may not clean up properly if it is aborted or if it encounters an unrecoverable error. In this case, a manual cleanup may be required, possibly including killing any running instances of `lctl`, removing `echo_client` instances created by the script and unloading `obdecho`.

33.5.2. Script Output

The `.summary` file and `stdout` of the `mds-survey` script contain lines like:

```
mdt 1 file 100000 dir 4 thr 4 create 5652.05 [ 999.01,46940.48] destroy 5797.79 [
```

Where:

Parameter and value	Description
<code>mdt 1</code>	Total number of MDT under test
<code>file 100000</code>	Total number of files per thread to operate

Parameter and value	Description
dir 4	Total number of directories to operate
thr 4	Total number of threads operate over all directories
create, destroy	Tests name. More tests will be displayed on the same line.
565.05	Aggregate operations over MDT measured by dividing the total number of operations by the elapsed time.
[999.01,46940.48]	Minimum and maximum instantaneous operation seen on any individual MDT

Note

If script output has "ERROR", this usually means there is issue during the run such as running out of space on the MDT and/or OST. More detailed debug information is available in the `#{rslt}.detail` file

33.6. Collecting Application Profiling Information (`stats-collect`)

The `stats-collect` utility contains the following scripts used to collect application profiling information from Lustre clients and servers:

- `lstat.sh` - Script for a single node that is run on each profile node.
- `gather_stats_everywhere.sh` - Script that collect statistics.
- `config.sh` - Script that contains customized configuration descriptions.

The `stats-collect` utility requires:

- Lustre software to be installed and set up on your cluster
- SSH and SCP access to these nodes without requiring a password

33.6.1. Using `stats-collect`

The `stats-collect` utility is configured by including profiling configuration variables in the `config.sh` script. Each configuration variable takes the following form, where 0 indicates statistics are to be collected only when the script starts and stops and *n* indicates the interval in seconds at which statistics are to be collected:

```
statistic_INTERVAL=0/n
```

Statistics that can be collected include:

- `VMSTAT` - Memory and CPU usage and aggregate read/write operations
- `SERVICE` - Lustre OST and MDT RPC service statistics
- `BRW` - OST bulk read/write statistics (`brw_stats`)
- `SDIO` - SCSI disk IO statistics (`sd_iostats`)

- MBALLOC - `ldiskfs` block allocation statistics
- IO - Lustre target operations statistics
- JBD - `ldiskfs` journal statistics
- CLIENT - Lustre OSC request statistics

To collect profile information:

Begin collecting statistics on each node specified in the `config.sh` script.

1. Starting the collect profile daemon on each node by entering:

```
sh gather_stats_everywhere.sh config.sh start
```

2. Run the test.
3. Stop collecting statistics on each node, clean up the temporary file, and create a profiling tarball.

Enter:

```
sh gather_stats_everywhere.sh config.sh stop log_name.tgz
```

When `log_name.tgz` is specified, a profile tarball `/tmp/log_name.tgz` is created.

4. Analyze the collected statistics and create a csv tarball for the specified profiling data.

```
sh gather_stats_everywhere.sh config.sh analyse log_tarball.tgz csv
```

Chapter 34. Tuning a Lustre File System

This chapter contains information about tuning a Lustre file system for better performance.

Note

Many options in the Lustre software are set by means of kernel module parameters. These parameters are contained in the `/etc/modprobe.d/lustre.conf` file.

34.1. Optimizing the Number of Service Threads

An OSS can have a minimum of two service threads and a maximum of 512 service threads. The number of service threads is a function of how much RAM and how many CPUs are on each OSS node (1 thread / 128MB * num_cpus). If the load on the OSS node is high, new service threads will be started in order to process more requests concurrently, up to 4x the initial number of threads (subject to the maximum of 512). For a 2GB 2-CPU system, the default thread count is 32 and the maximum thread count is 128.

Increasing the size of the thread pool may help when:

- Several OSTs are exported from a single OSS
- Back-end storage is running synchronously
- I/O completions take excessive time due to slow storage

Decreasing the size of the thread pool may help if:

- Clients are overwhelming the storage capacity
- There are lots of "slow I/O" or similar messages

Increasing the number of I/O threads allows the kernel and storage to aggregate many writes together for more efficient disk I/O. The OSS thread pool is shared--each thread allocates approximately 1.5 MB (maximum RPC size + 0.5 MB) for internal I/O buffers.

It is very important to consider memory consumption when increasing the thread pool size. Drives are only able to sustain a certain amount of parallel I/O activity before performance is degraded, due to the high number of seeks and the OST threads just waiting for I/O. In this situation, it may be advisable to decrease the load by decreasing the number of OST threads.

Determining the optimum number of OSS threads is a process of trial and error, and varies for each particular configuration. Variables include the number of OSTs on each OSS, number and speed of disks, RAID configuration, and available RAM. You may want to start with a number of OST threads equal to the number of actual disk spindles on the node. If you use RAID, subtract any dead spindles not used for actual data (e.g., 1 of N of spindles for RAID5, 2 of N spindles for RAID6), and monitor the performance of clients during usual workloads. If performance is degraded, increase the thread count and see how that works until performance is degraded again or you reach satisfactory performance.

Note

If there are too many threads, the latency for individual I/O requests can become very high and should be avoided. Set the desired maximum thread count permanently using the method described above.

34.1.1. Specifying the OSS Service Thread Count

The `oss_num_threads` parameter enables the number of OST service threads to be specified at module load time on the OSS nodes:

```
options ost oss_num_threads={N}
```

After startup, the minimum and maximum number of OSS thread counts can be set via the `{service}.thread_{min,max,started}` tunable. To change the tunable at runtime, run:

```
lctl {get,set}_param {service}.thread_{min,max,started}
```

This works in a similar fashion to binding of threads on MDS. MDS thread tuning is covered in Section 34.2, “Binding MDS Service Thread to CPU Partitions”.

- `oss_cpts=[EXPRESSION]` binds the default OSS service on CPTs defined by `[EXPRESSION]`.
- `oss_io_cpts=[EXPRESSION]` binds the IO OSS service on CPTs defined by `[EXPRESSION]`.

For further details, see Section 39.9, “Setting MDS and OSS Thread Counts”.

34.1.2. Specifying the MDS Service Thread Count

The `mds_num_threads` parameter enables the number of MDS service threads to be specified at module load time on the MDS node:

```
options mds mds_num_threads={N}
```

After startup, the minimum and maximum number of MDS thread counts can be set via the `{service}.thread_{min,max,started}` tunable. To change the tunable at runtime, run:

```
lctl {get,set}_param {service}.thread_{min,max,started}
```

For details, see Section 39.9, “Setting MDS and OSS Thread Counts”.

The number of MDS service threads started depends on system size and the load on the server, and has a default maximum of 64. The maximum potential number of threads (`MDS_MAX_THREADS`) is 1024.

Note

The OSS and MDS start two threads per service per CPT at mount time, and dynamically increase the number of running service threads in response to server load. Setting the `*_num_threads` module parameter starts the specified number of threads for that service immediately and disables automatic thread creation behavior.

Parameters are available to provide administrators control over the number of service threads.

- `mds_rdpd_num_threads` controls the number of threads in providing the read page service. The read page service handles file close and readdir operations.

34.2. Binding MDS Service Thread to CPU Partitions

With the Node Affinity (Node affinity) feature, MDS threads can be bound to particular CPU partitions (CPTs) to improve CPU cache usage and memory locality. Default values for CPT counts and CPU core bindings are selected automatically to provide good overall performance for a given CPU count. However, an administrator can deviate from these setting if they choose. For details on specifying the mapping of CPU cores to CPTs see Section 34.4, “libcfs Tuning”.

- `mds_num_cpts=[EXPRESSION]` binds the default MDS service threads to CPTs defined by `EXPRESSION`. For example `mds_num_cpts=[0-3]` will bind the MDS service threads to `CPT[0,1,2,3]`.
- `mds_rdpd_num_cpts=[EXPRESSION]` binds the read page service threads to CPTs defined by `EXPRESSION`. The read page service handles file close and readdir requests. For example `mds_rdpd_num_cpts=[4]` will bind the read page threads to `CPT4`.

Parameters must be set before module load in the file `/etc/modprobe.d/lustre.conf`. For example:

Example 34.1. lustre.conf

```
options lnet networks=tcp0(eth0)
options mdt mds_num_cpts=[0]
```

34.3. Tuning LNet Parameters

This section describes LNet tunables, the use of which may be necessary on some systems to improve performance. To test the performance of your Lustre network, see Chapter 32, *Testing Lustre Network Performance (LNet Self-Test)*.

34.3.1. Transmit and Receive Buffer Size

The kernel allocates buffers for sending and receiving messages on a network.

`ksocklnd` has separate parameters for the transmit and receive buffers.

```
options ksocklnd tx_buffer_size=0 rx_buffer_size=0
```

If these parameters are left at the default value (0), the system automatically tunes the transmit and receive buffer size. In almost every case, this default produces the best performance. Do not attempt to tune these parameters unless you are a network expert.

34.3.2. Hardware Interrupts (`enable_irq_affinity`)

The hardware interrupts that are generated by network adapters may be handled by any CPU in the system. In some cases, we would like network traffic to remain local to a single CPU to help keep the processor cache warm and minimize the impact of context switches. This is helpful when an SMP system has more than one network interface and ideal when the number of interfaces equals the number of CPUs. To enable the `enable_irq_affinity` parameter, enter:

```
options ksocklnd enable_irq_affinity=1
```

In other cases, if you have an SMP platform with a single fast interface such as 10 Gb Ethernet and more than two CPUs, you may see performance improve by turning this parameter off.

```
options ksocklnd enable_irq_affinity=0
```

By default, this parameter is off. As always, you should test the performance to compare the impact of changing this parameter.

34.3.3. Binding Network Interface Against CPU Partitions

Lustre allows enhanced network interface control. This means that an administrator can bind an interface to one or more CPU partitions. Bindings are specified as options to the LNet modules. For more information on specifying module options, see Section 43.1, “Introduction”

For example, `o2ib0(ib0)[0,1]` will ensure that all messages for `o2ib0` will be handled by LND threads executing on `CPT0` and `CPT1`. An additional example might be: `tcp1(eth0)[0]`. Messages for `tcp1` are handled by threads on `CPT0`.

34.3.4. Network Interface Credits

Network interface (NI) credits are shared across all CPU partitions (CPT). For example, if a machine has four CPTs and the number of NI credits is 512, then each partition has 128 credits. If a large number of CPTs exist on the system, LNet checks and validates the NI credits for each CPT to ensure each CPT has a workable number of credits. For example, if a machine has 16 CPTs and the number of NI credits is 256, then each partition only has 16 credits. 16 NI credits is low and could negatively impact performance. As a result, LNet automatically adjusts the credits to $8 * \text{peer_credits}$ (`peer_credits` is 8 by default), so each partition has 64 credits.

Increasing the number of `credits/peer_credits` can improve the performance of high latency networks (at the cost of consuming more memory) by enabling LNet to send more inflight messages to a specific network/peer and keep the pipeline saturated.

An administrator can modify the NI credit count using `ksocklnd` or `ko2iblnd`. In the example below, 256 credits are applied to TCP connections.

```
ksocklnd credits=256
```

Applying 256 credits to IB connections can be achieved with:

```
ko2iblnd credits=256
```

Note

LNet may revalidate the NI credits, so the administrator's request may not persist.

34.3.5. Router Buffers

When a node is set up as an LNet router, three pools of buffers are allocated: tiny, small and large. These pools are allocated per CPU partition and are used to buffer messages that arrive at the router to be forwarded to the next hop. The three different buffer sizes accommodate different size messages.

If a message arrives that can fit in a tiny buffer then a tiny buffer is used, if a message doesn't fit in a tiny buffer, but fits in a small buffer, then a small buffer is used. Finally if a message does not fit in either a tiny buffer or a small buffer, a large buffer is used.

Router buffers are shared by all CPU partitions. For a machine with a large number of CPTs, the router buffer number may need to be specified manually for best performance. A low number of router buffers risks starving the CPU partitions of resources.

- `tiny_router_buffers`: Zero payload buffers used for signals and acknowledgements.
- `small_router_buffers`: 4 KB payload buffers for small messages
- `large_router_buffers`: 1 MB maximum payload buffers, corresponding to the recommended RPC size of 1 MB.

The default setting for router buffers typically results in acceptable performance. LNet automatically sets a default value to reduce the likelihood of resource starvation. The size of a router buffer can be modified as shown in the example below. In this example, the size of the large buffer is modified using the `large_router_buffers` parameter.

```
lnet large_router_buffers=8192
```

Note

LNet may revalidate the router buffer setting, so the administrator's request may not persist.

34.3.6. Portal Round-Robin

Portal round-robin defines the policy LNet applies to deliver events and messages to the upper layers. The upper layers are PLRPC service or LNet selftest.

If portal round-robin is disabled, LNet will deliver messages to CPTs based on a hash of the source NID. Hence, all messages from a specific peer will be handled by the same CPT. This can reduce data traffic between CPUs. However, for some workloads, this behavior may result in poorly balancing loads across the CPU.

If portal round-robin is enabled, LNet will round-robin incoming events across all CPTs. This may balance load better across the CPU but can incur a cross CPU overhead.

The current policy can be changed by an administrator with `lctl set_param portal_rotor=value`. There are four options for `value` :

- `OFF`
Disable portal round-robin on all incoming requests.
- `ON`
Enable portal round-robin on all incoming requests.
- `RR_RT`
Enable portal round-robin only for routed messages.

- `HASH_RT`

Routed messages will be delivered to the upper layer by hash of source NID (instead of NID of router.) This is the default value.

34.3.7. LNet Peer Health

Two options are available to help determine peer health:

- `peer_timeout`- The timeout (in seconds) before an aliveness query is sent to a peer. For example, if `peer_timeout` is set to `180sec`, an aliveness query is sent to the peer every 180 seconds. This feature only takes effect if the node is configured as an LNet router.

In a routed environment, the `peer_timeout` feature should always be on (set to a value in seconds) on routers. If the router checker has been enabled, the feature should be turned off by setting it to 0 on clients and servers.

For a non-routed scenario, enabling the `peer_timeout` option provides health information such as whether a peer is alive or not. For example, a client is able to determine if an MGS or OST is up when it sends it a message. If a response is received, the peer is alive; otherwise a timeout occurs when the request is made.

In general, `peer_timeout` should be set to no less than the LND timeout setting. For more information about LND timeouts, see Section 39.5.2, “Setting Static Timeouts”.

When the `o2iblnd(IB)` driver is used, `peer_timeout` should be at least twice the value of the `ko2iblnd` keepalive option. for more information about keepalive options, see Section 43.2.2, “SOCKLND Kernel TCP/IP LND”.

- `avoid_asym_router_failure`- When set to 1, this parameter adds the additional requirement that for a route to be considered up the gateway of the route must have at least one NI up on the remote network of the route. This new requirement applies only to routes that are single-hop, which means that either the route's hop value is explicitly set to 1, or that it can be inferred that the route is single-hop. The default setting is 1.

The inference of a single-hop routes works as follows: If the router checker is running on a node, the node will periodically ping all of its gateways, which are routers on the same lnet that are listed in the node's routes. The gateways' responses will include the status of all their network interfaces (NIs). If a node A has a route R through gateway B to network C, and node A sees that router B has at least one NI that connects directly to network C (in a ping response from B), node A will infer that R is a single-hop route. This aspect of single-hop is independent of the hop value of the route. For more information about the LNet routes parameter, see Section 9.5, “Setting the LNet Module routes Parameter”

It is recommended to specify `hop=1` when creating a single-hop route when this feature is enabled. When a route truly has only 1 hop, it is still recommended to explicitly set `hop=1` because the single-hop inference mechanism will fail in cases where NIs fail to ever come up at all. This is because for the route inference to work, the NIs must at least come up or the gateway won't even mention them in the ping response, so the node won't see any mention of the remote net of the route in the gateway's NIs, and will mistakenly consider the route to be multi-hop, and `avoid_asym_router_failure` will then have no effect unless `hop=1` is set explicitly when the route is created.

In the following examples, nodes running lnet are circles, networks are squares, and NIs are lines labeled by their NIDs. There is a client C and a router X. C has routes to networks `o2ib0` and `o2ib1` with X as the gateway. If an NI is red with it's name crossed out, C considers it to be down, otherwise C considers it to be up.

Figure 34.1. One of Two Connections to o2ib0 Down

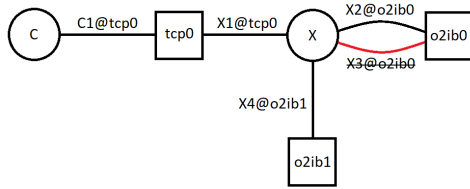

In the above figure, one of two NIs that connect to o2ib0 is up, so the route to o2ib0 is considered up.

Figure 34.2. Both Connections to o2ib0 Down

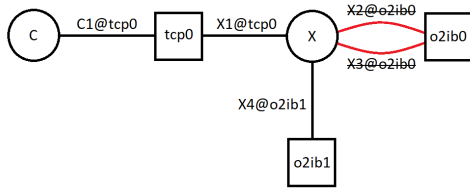

In the above figure, zero NIs that connect to o2ib0 are up, so the route to o2ib0 is down.

Figure 34.3. Connection to o2ib1 Down

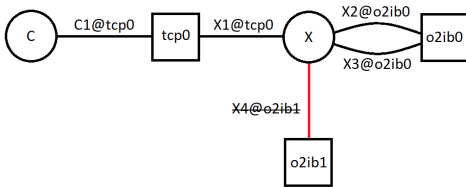

In the above figure, zero NIs that connect to o2ib1 are up, so the route to o2ib1 is down.

Figure 34.4. Connection to o2ib1 Never Came Up

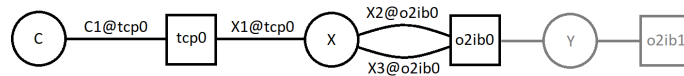

Compare Figures 34.3 and 34.4. In 34.4, X4@o2ib1 never came up (rather than coming up and then going down). Consequently, X did not list X4@o2ib1 in its ping response, so C cannot infer that X should be directly connected to o2ib1. If C has a route to o2ib1 through X, and the hop count is not set to 1 by the sysadmin, LNet assumes that X has a route to o2ib1 through some remote router node, such as Y. The gray part of Figure 34.4 shows the sort of configuration that LNet incorrectly assumes in this situation. Therefore, C will try to send messages for o2ib1 through X, where they will be dropped. If the sysadmin explicitly sets hop=1 for the route to o2ib1 (on C), LNet will know that if X does not report an NI on o2ib1, that the route should be marked as down.

The following router checker parameters must be set to the maximum value of the corresponding setting for this option on any client or server:

- `dead_router_check_interval`
- `live_router_check_interval`
- `router_ping_timeout`

For example, the `dead_router_check_interval` parameter on any router must be `MAX`.

34.4. libcfs Tuning

Lustre allows binding service threads via CPU Partition Tables (CPTs). This allows the system administrator to fine-tune on which CPU cores the Lustre service threads are run, for both OSS and MDS services, as well as on the client.

CPTs are useful to reserve some cores on the OSS or MDS nodes for system functions such as system monitoring, HA heartbeat, or similar tasks. On the client it may be useful to restrict Lustre RPC service threads to a small subset of cores so that they do not interfere with computation, or because these cores are directly attached to the network interfaces.

By default, the Lustre software will automatically generate CPU partitions (CPT) based on the number of CPUs in the system. The CPT count can be explicitly set on the libcfs module using `cpu_npartitions=NUMBER`. The value of `cpu_npartitions` must be an integer between 1 and the number of online CPUs.

Introduced in Lustre 2.9

In Lustre 2.9 and later the default is to use one CPT per NUMA node. In earlier versions of Lustre, by default there was a single CPT if the online CPU core count was four or fewer, and additional CPTs would be created depending on the number of CPU cores, typically with 4-8 cores per CPT.

Tip

Setting `cpu_npartitions=1` will disable most of the SMP Node Affinity functionality.

34.4.1. CPU Partition String Patterns

CPU partitions can be described using string pattern notation. If `cpu_pattern=N` is used, then there will be one CPT for each NUMA node in the system, with each CPT mapping all of the CPU cores for that NUMA node.

It is also possible to explicitly specify the mapping between CPU cores and CPTs, for example:

- `cpu_pattern="0[2,4,6] 1[3,5,7]"`

Create two CPTs, CPT0 contains cores 2, 4, and 6, while CPT1 contains cores 3, 5, 7. CPU cores 0 and 1 will not be used by Lustre service threads, and could be used for node services such as system monitoring, HA heartbeat threads, etc. The binding of non-Lustre services to those CPU cores may be done in userspace using `numactl(8)` or other application-specific methods, but is beyond the scope of this document.

- `cpu_pattern="N 0[0-3] 1[4-7]"`

Create two CPTs, with CPT0 containing all CPUs in NUMA node[0-3], while CPT1 contains all CPUs in NUMA node [4-7].

The current configuration of the CPU partition can be read via `lctl get_param cpu_partition_table`. For example, a simple 4-core system has a single CPT with all four CPU cores:

```
$ lctl get_param cpu_partition_table
cpu_partition_table=0 : 0 1 2 3
```

while a larger NUMA system with four 12-core CPUs may have four CPTs:

```
$ lctl get_param cpu_partition_table
cpu_partition_table=
0 : 0 1 2 3 4 5 6 7 8 9 10 11
1 : 12 13 14 15 16 17 18 19 20 21 22 23
2 : 24 25 26 27 28 29 30 31 32 33 34 35
3 : 36 37 38 39 40 41 42 43 44 45 46 47
```

34.5. LND Tuning

LND tuning allows the number of threads per CPU partition to be specified. An administrator can set the threads for both `ko2iblnd` and `ksocklnd` using the `nscheds` parameter. This adjusts the number of threads for each partition, not the overall number of threads on the LND.

Note

The default number of threads for `ko2iblnd` and `ksocklnd` are automatically set and are chosen to work well across a number of typical scenarios, for systems with both high and low core counts.

34.5.1. ko2iblnd Tuning

The following table outlines the `ko2iblnd` module parameters to be used for tuning:

Module Parameter	Default Value	Description
<code>service</code>	987	Service number (within <code>RDMA_PS_TCP</code>).
<code>cksum</code>	0	Set non-zero to enable message (not RDMA) checksums.
<code>timeout</code>	50	Timeout in seconds.
<code>nscheds</code>	0	Number of threads in each scheduler pool (per CPT). Value of zero means we derive the number from the number of cores.
<code>conns_per_peer</code>	4 (OmniPath), 1 (Everything else)	Introduced in 2.10. Number of connections to each peer. Messages are sent round-robin over the connection pool. Provides significant improvement with OmniPath.
<code>ntx</code>	512	Number of message descriptors allocated for each pool at startup. Grows at runtime. Shared by all CPTs.

Module Parameter	Default Value	Description
credits	256	Number of concurrent sends on network.
peer_credits	8	Number of concurrent sends to 1 peer. Related/limited by IB queue size.
peer_credits_hiw	0	When eagerly to return credits.
peer_buffer_credits	0	Number per-peer router buffer credits.
peer_timeout	180	Seconds without aliveness news to declare peer dead (less than or equal to 0 to disable).
ipif_name	ib0	IPoIB interface name.
retry_count	5	Retransmissions when no ACK received.
rnr_retry_count	6	RNR retransmissions.
keepalive	100	Idle time in seconds before sending a keepalive.
ib_mtu	0	IB MTU 256/512/1024/2048/4096.
concurrent_sends	0	Send work-queue sizing. If zero, derived from map_on_demand and peer_credits.
map_on_demand	0 (pre-4.8 Linux) 1 (4.8 Linux onward) 32 (OmniPath)	Number of fragments reserved for connection. If zero, use global memory region (found to be security issue). If non-zero, use FMR or FastReg for memory registration. Value needs to agree between both peers of connection.
fmr_pool_size	512	Size of fmr pool on each CPT ($\geq ntx / 4$). Grows at runtime.
fmr_flush_trigger	384	Number dirty FMRs that triggers pool flush.
fmr_cache	1	Non-zero to enable FMR caching.
dev_failover	0	HCA failover for bonding (0 OFF, 1 ON, other values reserved).
require_privileged_port	0	Require privileged port when accepting connection.
use_privileged_port	1	Use privileged port when initiating connection.
wrq_sge	2	Introduced in 2.10. Number scatter/gather element groups per work request. Used to deal with fragmentations which can

Module Parameter	Default Value	Description
		consume double the number of work requests.

34.6. Network Request Scheduler (NRS) Tuning

The Network Request Scheduler (NRS) allows the administrator to influence the order in which RPCs are handled at servers, on a per-PTLRPC service basis, by providing different policies that can be activated and tuned in order to influence the RPC ordering. The aim of this is to provide for better performance, and possibly discrete performance characteristics using future policies.

The NRS policy state of a PTLRPC service can be read and set via the `{service}.nrs_policies` tunable. To read a PTLRPC service's NRS policy state, run:

```
lctl get_param {service}.nrs_policies
```

For example, to read the NRS policy state of the `ost_io` service, run:

```
$ lctl get_param ost.OSS.ost_io.nrs_policies
ost.OSS.ost_io.nrs_policies=
```

```
regular_requests:
- name: fifo
  state: started
  fallback: yes
  queued: 0
  active: 0

- name: crrn
  state: stopped
  fallback: no
  queued: 0
  active: 0

- name: orr
  state: stopped
  fallback: no
  queued: 0
  active: 0

- name: trr
  state: started
  fallback: no
  queued: 2420
  active: 268

- name: tbf
  state: stopped
  fallback: no
```

```
    queued: 0
    active: 0

- name: delay
  state: stopped
  fallback: no
  queued: 0
  active: 0

high_priority_requests:
- name: fifo
  state: started
  fallback: yes
  queued: 0
  active: 0

- name: crrn
  state: stopped
  fallback: no
  queued: 0
  active: 0

- name: orr
  state: stopped
  fallback: no
  queued: 0
  active: 0

- name: trr
  state: stopped
  fallback: no
  queued: 0
  active: 0

- name: tbf
  state: stopped
  fallback: no
  queued: 0
  active: 0

- name: delay
  state: stopped
  fallback: no
  queued: 0
  active: 0
```

NRS policy state is shown in either one or two sections, depending on the PTLRPC service being queried. The first section is named `regular_requests` and is available for all PTLRPC services, optionally followed by a second section which is named `high_priority_requests`. This is because some PTLRPC services are able to treat some types of RPCs as higher priority ones, such that they are handled by the server with higher priority compared to other, regular RPC traffic. For PTLRPC services that do not support high-priority RPCs, you will only see the `regular_requests` section.

There is a separate instance of each NRS policy on each PTLRPC service for handling regular and high-priority RPCs (if the service supports high-priority RPCs). For each policy instance, the following fields are shown:

Field	Description
name	The name of the policy.
state	The state of the policy; this can be any of <code>invalid</code> , <code>stopping</code> , <code>stopped</code> , <code>starting</code> , <code>started</code> . A fully enabled policy is in the <code>started</code> state.
fallback	Whether the policy is acting as a fallback policy or not. A fallback policy is used to handle RPCs that other enabled policies fail to handle, or do not support the handling of. The possible values are <code>no</code> , <code>yes</code> . Currently, only the FIFO policy can act as a fallback policy.
queued	The number of RPCs that the policy has waiting to be serviced.
active	The number of RPCs that the policy is currently handling.

To enable an NRS policy on a PTLRPC service run:

```
lctl set_param {service}.nrs_policies=  
policy_name
```

This will enable the policy `policy_name` for both regular and high-priority RPCs (if the PLRPC service supports high-priority RPCs) on the given service. For example, to enable the CRR-N NRS policy for the `ldlm_cbd` service, run:

```
$ lctl set_param ldlm.services.ldlm_cbd.nrs_policies=crrn  
ldlm.services.ldlm_cbd.nrs_policies=crrn
```

For PTLRPC services that support high-priority RPCs, you can also supply an optional `reg/hp` token, in order to enable an NRS policy for handling only regular or high-priority RPCs on a given PTLRPC service, by running:

```
lctl set_param {service}.nrs_policies="  
policy_name  
reg/hp"
```

For example, to enable the TRR policy for handling only regular, but not high-priority RPCs on the `ost_io` service, run:

```
$ lctl set_param ost.OSS.ost_io.nrs_policies="trr reg"  
ost.OSS.ost_io.nrs_policies="trr reg"
```

Note

When enabling an NRS policy, the policy name must be given in lower-case characters, otherwise the operation will fail with an error message.

34.6.1. First In, First Out (FIFO) policy

The first in, first out (FIFO) policy handles RPCs in a service in the same order as they arrive from the LNet layer, so no special processing takes place to modify the RPC handling stream. FIFO is the default policy for all types of RPCs on all PTLRPC services, and is always enabled irrespective of the state of other policies, so that it can be used as a backup policy, in case a more elaborate policy that has been enabled fails to handle an RPC, or does not support handling a given type of RPC.

The FIFO policy has no tunables that adjust its behaviour.

34.6.2. Client Round-Robin over NIDs (CRR-N) policy

The client round-robin over NIDs (CRR-N) policy performs batched round-robin scheduling of all types of RPCs, with each batch consisting of RPCs originating from the same client node, as identified by its NID. CRR-N aims to provide for better resource utilization across the cluster, and to help shorten completion times of jobs in some cases, by distributing available bandwidth more evenly across all clients.

The CRR-N policy can be enabled on all types of PTLRPC services, and has the following tunable that can be used to adjust its behavior:

- `{service}.nrs_crrn_quantum`

The `{service}.nrs_crrn_quantum` tunable determines the maximum allowed size of each batch of RPCs; the unit of measure is in number of RPCs. To read the maximum allowed batch size of a CRR-N policy, run:

```
lctl get_param {service}.nrs_crrn_quantum
```

For example, to read the maximum allowed batch size of a CRR-N policy on the `ost_io` service, run:

```
$ lctl get_param ost.OSS.ost_io.nrs_crrn_quantum
ost.OSS.ost_io.nrs_crrn_quantum=reg_quantum:16
hp_quantum:8
```

You can see that there is a separate maximum allowed batch size value for regular (`reg_quantum`) and high-priority (`hp_quantum`) RPCs (if the PTLRPC service supports high-priority RPCs).

To set the maximum allowed batch size of a CRR-N policy on a given service, run:

```
lctl set_param {service}.nrs_crrn_quantum=
1-65535
```

This will set the maximum allowed batch size on a given service, for both regular and high-priority RPCs (if the PLRPC service supports high-priority RPCs), to the indicated value.

For example, to set the maximum allowed batch size on the `ldlm_canceld` service to 16 RPCs, run:

```
$ lctl set_param ldlm.services.ldlm_cancelld.nrs_crrn_quantum=16
ldlm.services.ldlm_cancelld.nrs_crrn_quantum=16
```

For PTLRPC services that support high-priority RPCs, you can also specify a different maximum allowed batch size for regular and high-priority RPCs, by running:

```
$ lctl set_param {service}.nrs_crrn_quantum=
reg_quantum/hp_quantum:
1-65535"
```

For example, to set the maximum allowed batch size on the `ldlm_cancelld` service, for high-priority RPCs to 32, run:

```
$ lctl set_param ldlm.services.ldlm_cancelld.nrs_crrn_quantum="hp_quantum:32"
ldlm.services.ldlm_cancelld.nrs_crrn_quantum=hp_quantum:32
```

By using the last method, you can also set the maximum regular and high-priority RPC batch sizes to different values, in a single command invocation.

34.6.3. Object-based Round-Robin (ORR) policy

The object-based round-robin (ORR) policy performs batched round-robin scheduling of bulk read write (brw) RPCs, with each batch consisting of RPCs that pertain to the same backend-file system object, as identified by its OST FID.

The ORR policy is only available for use on the `ost_io` service. The RPC batches it forms can potentially consist of mixed bulk read and bulk write RPCs. The RPCs in each batch are ordered in an ascending manner, based on either the file offsets, or the physical disk offsets of each RPC (only applicable to bulk read RPCs).

The aim of the ORR policy is to provide for increased bulk read throughput in some cases, by ordering bulk read RPCs (and potentially bulk write RPCs), and thus minimizing costly disk seek operations. Performance may also benefit from any resulting improvement in resource utilization, or by taking advantage of better locality of reference between RPCs.

The ORR policy has the following tunables that can be used to adjust its behaviour:

- `ost.OSS.ost_io.nrs_orr_quantum`

The `ost.OSS.ost_io.nrs_orr_quantum` tunable determines the maximum allowed size of each batch of RPCs; the unit of measure is in number of RPCs. To read the maximum allowed batch size of the ORR policy, run:

```
$ lctl get_param ost.OSS.ost_io.nrs_orr_quantum
ost.OSS.ost_io.nrs_orr_quantum=reg_quantum:256
hp_quantum:16
```

You can see that there is a separate maximum allowed batch size value for regular (`reg_quantum`) and high-priority (`hp_quantum`) RPCs (if the PTLRPC service supports high-priority RPCs).

To set the maximum allowed batch size for the ORR policy, run:

```
$ lctl set_param ost.OSS.ost_io.nrs_orr_quantum=
1-65535
```

This will set the maximum allowed batch size for both regular and high-priority RPCs, to the indicated value.

You can also specify a different maximum allowed batch size for regular and high-priority RPCs, by running:

```
$ lctl set_param ost.OSS.ost_io.nrs_orr_quantum=
reg_quantum/hp_quantum:
1-65535
```

For example, to set the maximum allowed batch size for regular RPCs to 128, run:

```
$ lctl set_param ost.OSS.ost_io.nrs_orr_quantum=reg_quantum:128
ost.OSS.ost_io.nrs_orr_quantum=reg_quantum:128
```

By using the last method, you can also set the maximum regular and high-priority RPC batch sizes to different values, in a single command invocation.

- `ost.OSS.ost_io.nrs_orr_offset_type`

The `ost.OSS.ost_io.nrs_orr_offset_type` tunable determines whether the ORR policy orders RPCs within each batch based on logical file offsets or physical disk offsets. To read the offset type value for the ORR policy, run:

```
$ lctl get_param ost.OSS.ost_io.nrs_orr_offset_type
ost.OSS.ost_io.nrs_orr_offset_type=reg_offset_type:physical
hp_offset_type:logical
```

You can see that there is a separate offset type value for regular (`reg_offset_type`) and high-priority (`hp_offset_type`) RPCs.

To set the ordering type for the ORR policy, run:

```
$ lctl set_param ost.OSS.ost_io.nrs_orr_offset_type=
physical/logical
```

This will set the offset type for both regular and high-priority RPCs, to the indicated value.

You can also specify a different offset type for regular and high-priority RPCs, by running:

```
$ lctl set_param ost.OSS.ost_io.nrs_orr_offset_type=  
reg_offset_type/hp_offset_type:  
physical/logical
```

For example, to set the offset type for high-priority RPCs to physical disk offsets, run:

```
$ lctl set_param ost.OSS.ost_io.nrs_orr_offset_type=hp_offset_type:physical  
ost.OSS.ost_io.nrs_orr_offset_type=hp_offset_type:physical
```

By using the last method, you can also set offset type for regular and high-priority RPCs to different values, in a single command invocation.

Note

Irrespective of the value of this tunable, only logical offsets can, and are used for ordering bulk write RPCs.

- `ost.OSS.ost_io.nrs_orr_supported`

The `ost.OSS.ost_io.nrs_orr_supported` tunable determines the type of RPCs that the ORR policy will handle. To read the types of supported RPCs by the ORR policy, run:

```
$ lctl get_param ost.OSS.ost_io.nrs_orr_supported  
ost.OSS.ost_io.nrs_orr_supported=reg_supported:reads  
hp_supported=reads_and_writes
```

You can see that there is a separate supported 'RPC types' value for regular (`reg_supported`) and high-priority (`hp_supported`) RPCs.

To set the supported RPC types for the ORR policy, run:

```
$ lctl set_param ost.OSS.ost_io.nrs_orr_supported=  
reads/writes/reads_and_writes
```

This will set the supported RPC types for both regular and high-priority RPCs, to the indicated value.

You can also specify a different supported 'RPC types' value for regular and high-priority RPCs, by running:

```
$ lctl set_param ost.OSS.ost_io.nrs_orr_supported=  
reg_supported/hp_supported:  
reads/writes/reads_and_writes
```

For example, to set the supported RPC types to bulk read and bulk write RPCs for regular requests, run:

```
$ lctl set_param  
ost.OSS.ost_io.nrs_orr_supported=reg_supported:reads_and_writes  
ost.OSS.ost_io.nrs_orr_supported=reg_supported:reads_and_writes
```

By using the last method, you can also set the supported RPC types for regular and high-priority RPC to different values, in a single command invocation.

34.6.4. Target-based Round-Robin (TRR) policy

The target-based round-robin (TRR) policy performs batched round-robin scheduling of brw RPCs, with each batch consisting of RPCs that pertain to the same OST, as identified by its OST index.

The TRR policy is identical to the object-based round-robin (ORR) policy, apart from using the brw RPC's target OST index instead of the backend-fs object's OST FID, for determining the RPC scheduling order. The goals of TRR are effectively the same as for ORR, and it uses the following tunables to adjust its behaviour:

- `ost.OSS.ost_io.nrs_trr_quantum`

The purpose of this tunable is exactly the same as for the `ost.OSS.ost_io.nrs_orr_quantum` tunable for the ORR policy, and you can use it in exactly the same way.

- `ost.OSS.ost_io.nrs_trr_offset_type`

The purpose of this tunable is exactly the same as for the `ost.OSS.ost_io.nrs_orr_offset_type` tunable for the ORR policy, and you can use it in exactly the same way.

- `ost.OSS.ost_io.nrs_trr_supported`

The purpose of this tunable is exactly the same as for the `ost.OSS.ost_io.nrs_orr_supported` tunable for the ORR policy, and you can use it in exactly the same way.

Introduced in Lustre 2.6

34.6.5. Token Bucket Filter (TBF) policy

The TBF (Token Bucket Filter) is a Lustre NRS policy which enables Lustre services to enforce the RPC rate limit on clients/jobs for QoS (Quality of Service) purposes.

Figure 34.5. The internal structure of TBF policy

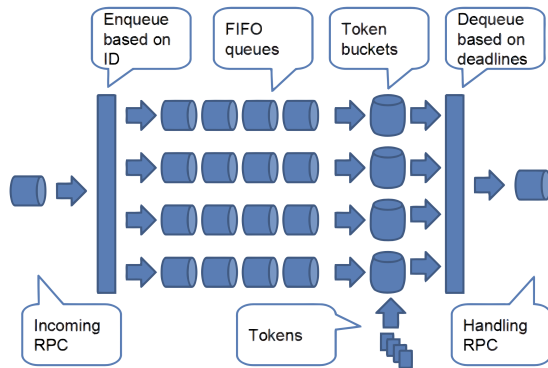

When a RPC request arrives, TBF policy puts it to a waiting queue according to its classification. The classification of RPC requests is based on either NID or JobID of the RPC according to the configure of

TBF. TBF policy maintains multiple queues in the system, one queue for each category in the classification of RPC requests. The requests wait for tokens in the FIFO queue before they have been handled so as to keep the RPC rates under the limits.

When Lustre services are too busy to handle all of the requests in time, all of the specified rates of the queues will not be satisfied. Nothing bad will happen except some of the RPC rates are slower than configured. In this case, the queue with higher rate will have an advantage over the queues with lower rates, but none of them will be starved.

To manage the RPC rate of queues, we don't need to set the rate of each queue manually. Instead, we define rules which TBF policy matches to determine RPC rate limits. All of the defined rules are organized as an ordered list. Whenever a queue is newly created, it goes through the rule list and takes the first matched rule as its rule, so that the queue knows its RPC token rate. A rule can be added to or removed from the list at run time. Whenever the list of rules is changed, the queues will update their matched rules.

34.6.5.1. Enable TBF policy

Command:

```
lctl set_param ost.OSS.ost_io.nrs_policies="tbf <policy>"
```

For now, the RPCs can be classified into the different types according to their NID, JOBID, OPCODE and UID/GID. When enabling TBF policy, you can specify one of the types, or just use "tbf" to enable all of them to do a fine-grained RPC requests classification.

Example:

```
$ lctl set_param ost.OSS.ost_io.nrs_policies="tbf"
$ lctl set_param ost.OSS.ost_io.nrs_policies="tbf nid"
$ lctl set_param ost.OSS.ost_io.nrs_policies="tbf jobid"
$ lctl set_param ost.OSS.ost_io.nrs_policies="tbf opcode"
$ lctl set_param ost.OSS.ost_io.nrs_policies="tbf uid"
$ lctl set_param ost.OSS.ost_io.nrs_policies="tbf gid"
```

34.6.5.2. Start a TBF rule

The TBF rule is defined in the parameter `ost.OSS.ost_io.nrs_tbf_rule`.

Command:

```
lctl set_param x.x.x.nrs_tbf_rule=
"[reg|hp] start rule_name arguments..."
```

'*rule_name*' is a string up to 15 characters which identifies the TBF policy rule's name. Alphanumeric characters and underscores are accepted (e.g: "test_rule_A1").

'*arguments*' is a string to specify the detailed rule according to the different types.

Next, the different types of TBF policies will be described.

- **NID based TBF policy**

Command:

```
lctl set_param x.x.x.nrs_tbf_rule=
```

```
"[reg|hp] start rule_name nid={nidlist} rate=rate"
```

'nidlist' uses the same format as configuring LNET route. 'rate' is the (upper limit) RPC rate of the rule.

Example:

```
$ lctl set_param ost.OSS.ost_io.nrs_tbf_rule=\
"start other_clients nid={192.168.*.*@tcp} rate=50"
$ lctl set_param ost.OSS.ost_io.nrs_tbf_rule=\
"start computes nid={192.168.1.[2-128]@tcp} rate=500"
$ lctl set_param ost.OSS.ost_io.nrs_tbf_rule=\
"start loginnode nid={192.168.1.1@tcp} rate=100"
```

In this example, the rate of processing RPC requests from compute nodes is at most 5x as fast as those from login nodes. The output of `ost.OSS.ost_io.nrs_tbf_rule` is like:

```
lctl get_param ost.OSS.ost_io.nrs_tbf_rule
ost.OSS.ost_io.nrs_tbf_rule=
regular_requests:
CPT 0:
loginnode {192.168.1.1@tcp} 100, ref 0
computes {192.168.1.[2-128]@tcp} 500, ref 0
other_clients {192.168.*.*@tcp} 50, ref 0
default {*} 10000, ref 0
high_priority_requests:
CPT 0:
loginnode {192.168.1.1@tcp} 100, ref 0
computes {192.168.1.[2-128]@tcp} 500, ref 0
other_clients {192.168.*.*@tcp} 50, ref 0
default {*} 10000, ref 0
```

Also, the rule can be written in `reg` and `hp` formats:

```
$ lctl set_param ost.OSS.ost_io.nrs_tbf_rule=\
"reg start loginnode nid={192.168.1.1@tcp} rate=100"
$ lctl set_param ost.OSS.ost_io.nrs_tbf_rule=\
"hp start loginnode nid={192.168.1.1@tcp} rate=100"
```

- **JobID based TBF policy**

For the JobID, please see Section 12.2, “Lustre Jobstats” for more details.

Command:

```
lctl set_param x.x.x.nrs_tbf_rule=
"[reg|hp] start rule_name jobid={jobid_list} rate=rate"
```

Wildcard is supported in {`jobid_list`}.

Example:

```
$ lctl set_param ost.OSS.ost_io.nrs_tbf_rule=\
"start iozone_user jobid={iozone.500} rate=100"
```

```
$ lctl set_param ost.OSS.ost_io.nrs_tbf_rule=\
"start dd_user jobid={dd.*} rate=50"
$ lctl set_param ost.OSS.ost_io.nrs_tbf_rule=\
"start user1 jobid={*.600} rate=10"
$ lctl set_param ost.OSS.ost_io.nrs_tbf_rule=\
"start user2 jobid={io*.10* *.500} rate=200"
```

Also, the rule can be written in reg and hp formats:

```
$ lctl set_param ost.OSS.ost_io.nrs_tbf_rule=\
"hp start iozone_user1 jobid={iozone.500} rate=100"
$ lctl set_param ost.OSS.ost_io.nrs_tbf_rule=\
"reg start iozone_user1 jobid={iozone.500} rate=100"
```

- **Opcode based TBF policy**

Command:

```
$ lctl set_param x.x.x.nrs_tbf_rule=
"[reg|hp] start rule_name opcode={opcode_list} rate=rate"
```

Example:

```
$ lctl set_param ost.OSS.ost_io.nrs_tbf_rule=\
"start user1 opcode={ost_read} rate=100"
$ lctl set_param ost.OSS.ost_io.nrs_tbf_rule=\
"start iozone_user1 opcode={ost_read ost_write} rate=200"
```

Also, the rule can be written in reg and hp formats:

```
$ lctl set_param ost.OSS.ost_io.nrs_tbf_rule=\
"hp start iozone_user1 opcode={ost_read} rate=100"
$ lctl set_param ost.OSS.ost_io.nrs_tbf_rule=\
"reg start iozone_user1 opcode={ost_read} rate=100"
```

- **UID/GID based TBF policy**

Command:

```
$ lctl set_param ost.OSS.*.nrs_tbf_rule=\
"[reg][hp] start rule_name uid={uid} rate=rate"
$ lctl set_param ost.OSS.*.nrs_tbf_rule=\
"[reg][hp] start rule_name gid={gid} rate=rate"
```

Example:

Limit the rate of RPC requests of the uid 500

```
$ lctl set_param ost.OSS.*.nrs_tbf_rule=\
"start tbf_name uid={500} rate=100"
```

Limit the rate of RPC requests of the gid 500

```
$ lctl set_param ost.OSS.*.nrs_tbf_rule=\
"start tbf_name gid={500} rate=100"
```

Also, you can use the following rule to control all reqs to mds:

Start the tbf uid QoS on MDS:

```
$ lctl set_param mds.MDS.*.nrs_policies="tbf uid"
```

Limit the rate of RPC requests of the uid 500

```
$ lctl set_param mds.MDS.*.nrs_tbf_rule=\
"start tbf_name uid={500} rate=100"
```

- **Policy combination**

To support TBF rules with complex expressions of conditions, TBF classifier is extended to classify RPC in a more fine-grained way. This feature supports logical conditional conjunction and disjunction operations among different types. In the rule: "&" represents the conditional conjunction and "," represents the conditional disjunction.

Example:

```
$ lctl set_param ost.OSS.ost_io.nrs_tbf_rule=\
"start comp_rule opcode={ost_write}&jobid={dd.0},\
nid={192.168.1.[1-128]@tcp 0@lo} rate=100"
```

In this example, those RPCs whose opcode is ost_write and jobid is dd.0, or nid satisfies the condition of {192.168.1.[1-128]@tcp 0@lo} will be processed at the rate of 100 req/sec. The output of ost.OSS.ost_io.nrs_tbf_rule is like:

```
$ lctl get_param ost.OSS.ost_io.nrs_tbf_rule
ost.OSS.ost_io.nrs_tbf_rule=
regular_requests:
CPT 0:
comp_rule opcode={ost_write}&jobid={dd.0},nid={192.168.1.[1-128]@tcp 0@lo} 100, 1
default * 10000, ref 0
CPT 1:
comp_rule opcode={ost_write}&jobid={dd.0},nid={192.168.1.[1-128]@tcp 0@lo} 100, 1
default * 10000, ref 0
high_priority_requests:
CPT 0:
comp_rule opcode={ost_write}&jobid={dd.0},nid={192.168.1.[1-128]@tcp 0@lo} 100, 1
default * 10000, ref 0
CPT 1:
comp_rule opcode={ost_write}&jobid={dd.0},nid={192.168.1.[1-128]@tcp 0@lo} 100, 1
default * 10000, ref 0
```

Example:

```
$ lctl set_param ost.OSS.*.nrs_tbf_rule=\
"start tbf_name uid={500}&gid={500} rate=100"
```

In this example, those RPC requests whose uid is 500 and gid is 500 will be processed at the rate of 100 req/sec.

34.6.5.3. Change a TBF rule

Command:

```
lctl set_param x.x.x.nrs_tbf_rule=
"[reg|hp] change rule_name rate=rate"
```

Example:

```
$ lctl set_param ost.OSS.ost_io.nrs_tbf_rule=\
"change loginnode rate=200"
$ lctl set_param ost.OSS.ost_io.nrs_tbf_rule=\
"reg change loginnode rate=200"
$ lctl set_param ost.OSS.ost_io.nrs_tbf_rule=\
"hp change loginnode rate=200"
```

34.6.5.4. Stop a TBF rule

Command:

```
lctl set_param x.x.x.nrs_tbf_rule="[reg|hp] stop
rule_name"
```

Example:

```
$ lctl set_param ost.OSS.ost_io.nrs_tbf_rule="stop loginnode"
$ lctl set_param ost.OSS.ost_io.nrs_tbf_rule="reg stop loginnode"
$ lctl set_param ost.OSS.ost_io.nrs_tbf_rule="hp stop loginnode"
```

34.6.5.5. Rule options

To support more flexible rule conditions, the following options are added.

- **Reordering of TBF rules**

By default, a newly started rule is prior to the old ones, but by specifying the argument 'rank=' when inserting a new rule with "start" command, the rank of the rule can be changed. Also, it can be changed by "change" command.

Command:

```
lctl set_param ost.OSS.ost_io.nrs_tbf_rule=
"start rule_name arguments... rank=obj_rule_name"
lctl set_param ost.OSS.ost_io.nrs_tbf_rule=
"change rule_name rate=rate rank=obj_rule_name"
```

By specifying the existing rule '*obj_rule_name*', the new rule '*rule_name*' will be moved to the front of '*obj_rule_name*'.

Example:

```
$ lctl set_param ost.OSS.ost_io.nrs_tbf_rule=\
"start computes nid={192.168.1.[2-128]@tcp} rate=500"
```

```
$ lctl set_param ost.OSS.ost_io.nrs_tbf_rule=\
"start user1 jobid={iozone.500 dd.500} rate=100"
$ lctl set_param ost.OSS.ost_io.nrs_tbf_rule=\
"start iozone_user1 opcode={ost_read ost_write} rate=200 rank=computes"
```

In this example, rule "iozone_user1" is added to the front of rule "computes". We can see the order by the following command:

```
$ lctl get_param ost.OSS.ost_io.nrs_tbf_rule
ost.OSS.ost_io.nrs_tbf_rule=
regular_requests:
CPT 0:
user1 jobid={iozone.500 dd.500} 100, ref 0
iozone_user1 opcode={ost_read ost_write} 200, ref 0
computes nid={192.168.1.[2-128]@tcp} 500, ref 0
default * 10000, ref 0
CPT 1:
user1 jobid={iozone.500 dd.500} 100, ref 0
iozone_user1 opcode={ost_read ost_write} 200, ref 0
computes nid={192.168.1.[2-128]@tcp} 500, ref 0
default * 10000, ref 0
high_priority_requests:
CPT 0:
user1 jobid={iozone.500 dd.500} 100, ref 0
iozone_user1 opcode={ost_read ost_write} 200, ref 0
computes nid={192.168.1.[2-128]@tcp} 500, ref 0
default * 10000, ref 0
CPT 1:
user1 jobid={iozone.500 dd.500} 100, ref 0
iozone_user1 opcode={ost_read ost_write} 200, ref 0
computes nid={192.168.1.[2-128]@tcp} 500, ref 0
default * 10000, ref 0
```

- **TBF realtime policies under congestion**

During TBF evaluation, we find that when the sum of I/O bandwidth requirements for all classes exceeds the system capacity, the classes with the same rate limits get less bandwidth than if preconfigured evenly. The reason for this is the heavy load on a congested server will result in some missed deadlines for some classes. The number of the calculated tokens may be larger than 1 during dequeuing. In the original implementation, all classes are equally handled to simply discard exceeding tokens.

Thus, a Hard Token Compensation (HTC) strategy has been implemented. A class can be configured with the HTC feature by the rule it matches. This feature means that requests in this kind of class queues have high real-time requirements and that the bandwidth assignment must be satisfied as good as possible. When deadline misses happen, the class keeps the deadline unchanged and the time residue (the remainder of elapsed time divided by 1/r) is compensated to the next round. This ensures that the next idle I/O thread will always select this class to serve until all accumulated exceeding tokens are handled or there are no pending requests in the class queue.

Command:

A new command format is added to enable the realtime feature for a rule:

```
lctl set_param x.x.x.nrs_tbf_rule=\
"start rule_name arguments... realtime=1"
```

Example:

```
$ lctl set_param ost.OSS.ost_io.nrs_tbf_rule=
"start realjob jobid={dd.0} rate=100 realtime=1
```

This example rule means the RPC requests whose JobID is dd.0 will be processed at the rate of 100req/sec in realtime.

Introduced in Lustre 2.10

34.6.6. Delay policy

The NRS Delay policy seeks to perturb the timing of request processing at the PtRPC layer, with the goal of simulating high server load, and finding and exposing timing related problems. When this policy is active, upon arrival of a request the policy will calculate an offset, within a defined, user-configurable range, from the request arrival time, to determine a time after which the request should be handled. The request is then stored using the `cfs_binheap` implementation, which sorts the request according to the assigned start time. Requests are removed from the binheap for handling once their start time has been passed.

The Delay policy can be enabled on all types of PtRPC services, and has the following tunables that can be used to adjust its behavior:

- `{service}.nrs_delay_min`

The `{service}.nrs_delay_min` tunable controls the minimum amount of time, in seconds, that a request will be delayed by this policy. The default is 5 seconds. To read this value run:

```
lctl get_param {service}.nrs_delay_min
```

For example, to read the minimum delay set on the `ost_io` service, run:

```
$ lctl get_param ost.OSS.ost_io.nrs_delay_min
ost.OSS.ost_io.nrs_delay_min=reg_delay_min:5
hp_delay_min:5
```

To set the minimum delay in RPC processing, run:

```
lctl set_param {service}.nrs_delay_min=0-65535
```

This will set the minimum delay time on a given service, for both regular and high-priority RPCs (if the PtRPC service supports high-priority RPCs), to the indicated value.

For example, to set the minimum delay time on the `ost_io` service to 10, run:

```
$ lctl set_param ost.OSS.ost_io.nrs_delay_min=10
ost.OSS.ost_io.nrs_delay_min=10
```

For PtRPC services that support high-priority RPCs, to set a different minimum delay time for regular and high-priority RPCs, run:

```
lctl set_param {service}.nrs_delay_min=reg_delay_min/hp_delay_min:0-65535
```

For example, to set the minimum delay time on the `ost_io` service for high-priority RPCs to 3, run:

```
$ lctl set_param ost.OSS.ost_io.nrs_delay_min=hp_delay_min:3
ost.OSS.ost_io.nrs_delay_min=hp_delay_min:3
```

Note, in all cases the minimum delay time cannot exceed the maximum delay time.

- `{service}.nrs_delay_max`

The `{service}.nrs_delay_max` tunable controls the maximum amount of time, in seconds, that a request will be delayed by this policy. The default is 300 seconds. To read this value run:

```
lctl get_param {service}.nrs_delay_max
```

For example, to read the maximum delay set on the `ost_io` service, run:

```
$ lctl get_param ost.OSS.ost_io.nrs_delay_max
ost.OSS.ost_io.nrs_delay_max=reg_delay_max:300
hp_delay_max:300
```

To set the maximum delay in RPC processing, run:

```
lctl set_param {service}.nrs_delay_max=0-65535
```

This will set the maximum delay time on a given service, for both regular and high-priority RPCs (if the `PtlRPC` service supports high-priority RPCs), to the indicated value.

For example, to set the maximum delay time on the `ost_io` service to 60, run:

```
$ lctl set_param ost.OSS.ost_io.nrs_delay_max=60
ost.OSS.ost_io.nrs_delay_max=60
```

For `PtlRPC` services that support high-priority RPCs, to set a different maximum delay time for regular and high-priority RPCs, run:

```
lctl set_param {service}.nrs_delay_max=reg_delay_max/hp_delay_max:0-65535
```

For example, to set the maximum delay time on the `ost_io` service for high-priority RPCs to 30, run:

```
$ lctl set_param ost.OSS.ost_io.nrs_delay_max=hp_delay_max:30
ost.OSS.ost_io.nrs_delay_max=hp_delay_max:30
```

Note, in all cases the maximum delay time cannot be less than the minimum delay time.

- `{service}.nrs_delay_pct`

The `{service}.nrs_delay_pct` tunable controls the percentage of requests that will be delayed by this policy. The default is 100. Note, when a request is not selected for handling by the delay policy due to this variable then the request will be handled by whatever fallback policy is defined for that

service. If no other fallback policy is defined then the request will be handled by the FIFO policy. To read this value run:

```
lctl get_param {service}.nrs_delay_pct
```

For example, to read the percentage of requests being delayed on the `ost_io` service, run:

```
$ lctl get_param ost.OSS.ost_io.nrs_delay_pct
ost.OSS.ost_io.nrs_delay_pct=reg_delay_pct:100
hp_delay_pct:100
```

To set the percentage of delayed requests, run:

```
lctl set_param {service}.nrs_delay_pct=0-100
```

This will set the percentage of requests delayed on a given service, for both regular and high-priority RPCs (if the PtlRPC service supports high-priority RPCs), to the indicated value.

For example, to set the percentage of delayed requests on the `ost_io` service to 50, run:

```
$ lctl set_param ost.OSS.ost_io.nrs_delay_pct=50
ost.OSS.ost_io.nrs_delay_pct=50
```

For PtlRPC services that support high-priority RPCs, to set a different delay percentage for regular and high-priority RPCs, run:

```
lctl set_param {service}.nrs_delay_pct=reg_delay_pct/hp_delay_pct:0-100
```

For example, to set the percentage of delayed requests on the `ost_io` service for high-priority RPCs to 5, run:

```
$ lctl set_param ost.OSS.ost_io.nrs_delay_pct=hp_delay_pct:5
ost.OSS.ost_io.nrs_delay_pct=hp_delay_pct:5
```

34.7. Lockless I/O Tunables

The lockless I/O tunable feature allows servers to ask clients to do lockless I/O (the server does the locking on behalf of clients) for contended files to avoid lock ping-pong.

The lockless I/O patch introduces these tunables:

- **OST-side:**

```
ldlm.namespaces.filter-fsname-*
```

`contended_locks`- If the number of lock conflicts in the scan of granted and waiting queues at `contended_locks` is exceeded, the resource is considered to be contended.

`contention_seconds`- The resource keeps itself in a contended state as set in the parameter.

`max_nolock_bytes`- Server-side locking set only for requests less than the blocks set in the `max_nolock_bytes` parameter. If this tunable is set to zero (0), it disables server-side locking for read/write requests.

- **Client-side:**

`llite.fsname-*`

`contention_seconds`- `llite` inode remembers its contended state for the time specified in this parameter.

- **Client-side statistics:**

The `llite.fsname-*.stats` parameter has several entries for lockless I/O statistics.

`lockless_read_bytes` and `lockless_write_bytes`- To count the total bytes read or written, the client makes its own decisions based on the request size. The client does not communicate with the server if the request size is smaller than the `min_nolock_size`, without acquiring locks by the client.

Introduced in Lustre 2.9

34.8. Server-Side Advice and Hinting

34.8.1. Overview

Use the `lfs ladvice` command to give file access advices or hints to servers.

```
lfs ladvice [--advice|-a ADVICE ] [--background|-b]
[--start|-s START[kMGT]]
{[--end|-e END[kMGT]] | [--length|-l LENGTH[kMGT]]}
file ...
```

Option	Description
<code>-a, --advice= ADVICE</code>	Give advice or hint of type <code>ADVICE</code> . Advice types are: <code>willread</code> to prefetch data into server cache <code>dontneed</code> to cleanup data cache on server <code>lockahead</code> Request an LDLM extent lock of the given mode on the given byte range <code>noexpand</code> Disable extent lock expansion behavior for I/O to this file descriptor
<code>-b, --background</code>	Enable the advices to be sent and handled asynchronously.
<code>-s, --start= START_OFFSET</code>	File range starts from <code>START_OFFSET</code>
<code>-e, --end= END_OFFSET</code>	File range ends at (not including) <code>END_OFFSET</code> . This option may not be specified at the same time as the <code>-l</code> option.

Option	Description
-l, --length= LENGTH	File range has length of LENGTH. This option may not be specified at the same time as the -e option.
-m, --mode= MODE	Lockahead request mode {READ,WRITE}. Request a lock with this mode.

Typically, `lfs ladvice` forwards the advice to Lustre servers without guaranteeing when and what servers will react to the advice. Actions may or may not triggered when the advices are recieved, depending on the type of the advice, as well as the real-time decision of the affected server-side components.

A typical usage of `ladvice` is to enable applications and users with external knowledge to intervene in server-side cache management. For example, if a bunch of different clients are doing small random reads of a file, prefetching pages into OSS cache with big linear reads before the random IO is a net benefit. Fetching that data into each client cache with `fadvise()` may not be, due to much more data being sent to the client.

`ladvice lockahead` is different in that it attempts to control LDLM locking behavior by explicitly requesting LDLM locks in advance of use. This does not directly affect caching behavior, instead it is used in special cases to avoid pathological results (lock exchange) from the normal LDLM locking behavior.

Note that the `noexpand` advice works on a specific file descriptor, so using it via `lfs` has no effect. It must be used on a particular file descriptor which is used for i/o to have any effect.

The main difference between the Linux `fadvise()` system call and `lfs ladvice` is that `fadvise()` is only a client side mechanism that does not pass the advice to the filesystem, while `ladvice` can send advices or hints to the Lustre server side.

34.8.2. Examples

The following example gives the OST(s) holding the first 1GB of `/mnt/lustre/file1a` hint that the first 1GB of the file will be read soon.

```
client1$ lfs ladvice -a willread -s 0 -e 1048576000 /mnt/lustre/file1
```

The following example gives the OST(s) holding the first 1GB of `/mnt/lustre/file1` a hint that the first 1GB of file will not be read in the near future, thus the OST(s) could clear the cache of the file in the memory.

```
client1$ lfs ladvice -a dontneed -s 0 -e 1048576000 /mnt/lustre/file1
```

The following example requests an LDLM read lock on the first 1 MiB of `/mnt/lustre/file1`. This will attempt to request a lock from the OST holding that region of the file.

```
client1$ lfs ladvice -a lockahead -m READ -s 0 -e 1M /mnt/lustre/file1
```

The following example requests an LDLM write lock on [3 MiB, 10 MiB] of `/mnt/lustre/file1`. This will attempt to request a lock from the OST holding that region of the file.

```
client1$ lfs ladvice -a lockahead -m WRITE -s 3M -e 10M /mnt/lustre/file1
```

Introduced in Lustre 2.9

34.9. Large Bulk IO (16MB RPC)

34.9.1. Overview

Beginning with Lustre 2.9, Lustre is extended to support RPCs up to 16MB in size. By enabling a larger RPC size, fewer RPCs will be required to transfer the same amount of data between clients and servers. With a larger RPC size, the OSS can submit more data to the underlying disks at once, therefore it can produce larger disk I/Os to fully utilize the increasing bandwidth of disks.

At client connection time, clients will negotiate with servers what the maximum RPC size it is possible to use, but the client can always send RPCs smaller than this maximum.

The parameter `brw_size` is used on the OST to tell the client the maximum (preferred) IO size. All clients that talk to this target should never send an RPC greater than this size. Clients can individually set a smaller RPC size limit via the `osc.*.max_pages_per_rpc` tunable.

Note

The smallest `brw_size` that can be set for ZFS OSTs is the `recordsize` of that dataset. This ensures that the client can always write a full ZFS file block if it has enough dirty data, and does not otherwise force it to do read-modify-write operations for every RPC.

34.9.2. Usage

In order to enable a larger RPC size, `brw_size` must be changed to an IO size value up to 16MB. To temporarily change `brw_size`, the following command should be run on the OSS:

```
oss# lctl set_param obdfilter.fsname-OST*.brw_size=16
```

To persistently change `brw_size`, the following command should be run:

```
oss# lctl set_param -P obdfilter.fsname-OST*.brw_size=16
```

When a client connects to an OST target, it will fetch `brw_size` from the target and pick the maximum value of `brw_size` and its local setting for `max_pages_per_rpc` as the actual RPC size. Therefore, the `max_pages_per_rpc` on the client side would have to be set to 16M, or 4096 if the `PAGESIZE` is 4KB, to enable a 16MB RPC. To temporarily make the change, the following command should be run on the client to set `max_pages_per_rpc`:

```
client$ lctl set_param osc.fsname-OST*.max_pages_per_rpc=16M
```

To persistently make this change, the following command should be run:

```
client$ lctl set_param -P obdfilter.fsname-OST*.osc.max_pages_per_rpc=16M
```

Caution

The `brw_size` of an OST can be changed on the fly. However, clients have to be remounted to renegotiate the new maximum RPC size.

34.10. Improving Lustre I/O Performance for Small Files

An environment where an application writes small file chunks from many clients to a single file can result in poor I/O performance. To improve the performance of the Lustre file system with small files:

- Have the application aggregate writes some amount before submitting them to the Lustre file system. By default, the Lustre software enforces POSIX coherency semantics, so it results in lock ping-pong between client nodes if they are all writing to the same file at one time.

Using MPI-IO Collective Write functionality in the Lustre ADIO driver is one way to achieve this in a straight forward manner if the application is already using MPI-IO.

- Have the application do 4kB `O_DIRECT` sized I/O to the file and disable locking on the output file. This avoids partial-page IO submissions and, by disabling locking, you avoid contention between clients.
- Have the application write contiguous data.
- Add more disks or use SSD disks for the OSTs. This dramatically improves the IOPS rate. Consider creating larger OSTs rather than many smaller OSTs due to less overhead (journal, connections, etc).
- Use RAID-1+0 OSTs instead of RAID-5/6. There is RAID parity overhead for writing small chunks of data to disk.

34.11. Understanding Why Write Performance is Better Than Read Performance

Typically, the performance of write operations on a Lustre cluster is better than read operations. When doing writes, all clients are sending write RPCs asynchronously. The RPCs are allocated, and written to disk in the order they arrive. In many cases, this allows the back-end storage to aggregate writes efficiently.

In the case of read operations, the reads from clients may come in a different order and need a lot of seeking to get read from the disk. This noticeably hampers the read throughput.

Currently, there is no readahead on the OSTs themselves, though the clients do readahead. If there are lots of clients doing reads it would not be possible to do any readahead in any case because of memory consumption (consider that even a single RPC (1 MB) readahead for 1000 clients would consume 1 GB of RAM).

For file systems that use `sockIn` (TCP, Ethernet) as interconnect, there is also additional CPU overhead because the client cannot receive data without copying it from the network buffers. In the write case, the client CAN send data without the additional data copy. This means that the client is more likely to become CPU-bound during reads than writes.

Part V. Troubleshooting a Lustre File System

Part V provides information about troubleshooting a Lustre file system. You will find information in this section about:

- Lustre File System Troubleshooting
 - Troubleshooting Recovery
 - Debugging a Lustre File System
-

Table of Contents

35. Lustre File System Troubleshooting	410
35.1. Lustre Error Messages	410
35.1.1. Error Numbers	410
35.1.2. Viewing Error Messages	411
35.2. Reporting a Lustre File System Bug	411
35.2.1. Searching Jira* for Duplicate Tickets	412
35.3. Common Lustre File System Problems	412
35.3.1. OST Object is Missing or Damaged	413
35.3.2. OSTs Become Read-Only	413
35.3.3. Identifying a Missing OST	414
35.3.4. Fixing a Bad LAST_ID on an OST	415
35.3.5. Handling/Debugging "bind: Address already in use" Error	415
35.3.6. Handling/Debugging Error "- 28"	416
35.3.7. Triggering Watchdog for PID NNN	418
35.3.8. Handling Timeouts on Initial Lustre File System Setup	418
35.3.9. Handling/Debugging "LustreError: xxx went back in time"	419
35.3.10. Lustre Error: "Slow Start_Page_Write"	419
35.3.11. Drawbacks in Doing Multi-client O_APPEND Writes	419
35.3.12. Slowdown Occurs During Lustre File System Startup	420
35.3.13. Log Message 'Out of Memory' on OST	420
35.3.14. Setting SCSI I/O Sizes	420
36. Troubleshooting Recovery	421
36.1. Recovering from Errors or Corruption on a Backing ldiskfs File System	421
36.2. Recovering from Corruption in the Lustre File System	422
36.2.1. Working with Orphaned Objects	422
36.3. Recovering from an Unavailable OST	422
36.4. Checking the file system with LFSCK	423
36.4.1. LFSCK switch interface	424
36.4.2. Check the LFSCK global status	L 2.9 426
36.4.3. LFSCK status interface	427
36.4.4. LFSCK adjustment interface	433
37. Debugging a Lustre File System	435
37.1. Diagnostic and Debugging Tools	435
37.1.1. Lustre Debugging Tools	435
37.1.2. External Debugging Tools	436
37.2. Lustre Debugging Procedures	437
37.2.1. Understanding the Lustre Debug Messaging Format	437
37.2.2. Using the lctl Tool to View Debug Messages	439
37.2.3. Dumping the Buffer to a File (debug_daemon)	440
37.2.4. Controlling Information Written to the Kernel Debug Log	441
37.2.5. Troubleshooting with strace	442
37.2.6. Looking at Disk Content	442
37.2.7. Finding the Lustre UUID of an OST	443
37.2.8. Printing Debug Messages to the Console	444
37.2.9. Tracing Lock Traffic	444
37.2.10. Controlling Console Message Rate Limiting	444
37.3. Lustre Debugging for Developers	444
37.3.1. Adding Debugging to the Lustre Source Code	444
37.3.2. Accessing the pctlrpc Request History	447
37.3.3. Finding Memory Leaks Using leak_finder.pl	448

Chapter 35. Lustre File System Troubleshooting

This chapter provides information about troubleshooting a Lustre file system, submitting a bug to the Jira bug tracking system, and Lustre file system performance tips. It includes the following sections:

- Section 35.1, “Lustre Error Messages”
- Section 35.2, “Reporting a Lustre File System Bug”
- Section 35.3, “Common Lustre File System Problems”

35.1. Lustre Error Messages

Several resources are available to help troubleshoot an issue in a Lustre file system. This section describes error numbers, error messages and logs.

35.1.1. Error Numbers

Error numbers are generated by the Linux operating system and are located in `/usr/include/asm-generic/errno.h`. The Lustre software does not use all of the available Linux error numbers. The exact meaning of an error number depends on where it is used. Here is a summary of the basic errors that Lustre file system users may encounter.

Error Number	Error Name	Description
-1	-EPERM	Permission is denied.
-2	-ENOENT	The requested file or directory does not exist.
-4	-EINTR	The operation was interrupted (usually CTRL-C or a killing process).
-5	-EIO	The operation failed with a read or write error.
-19	-ENODEV	No such device is available. The server stopped or failed over.
-22	-EINVAL	The parameter contains an invalid value.
-28	-ENOSPC	The file system is out-of-space or out of inodes. Use <code>lfs df</code> (query the amount of file system space) or <code>lfs df -i</code> (query the number of inodes).
-30	-EROFS	The file system is read-only, likely due to a detected error.
-43	-EIDRM	The UID/GID does not match any known UID/GID on the MDS. Update <code>etc/hosts</code> and <code>etc/group</code> on

Error Number	Error Name	Description
		the MDS to add the missing user or group.
-107	-ENOTCONN	The client is not connected to this server.
-110	-ETIMEDOUT	The operation took too long and timed out.
-122	-EDQUOT	The operation exceeded the user disk quota and was aborted.

35.1.2. Viewing Error Messages

As Lustre software code runs on the kernel, single-digit error codes display to the application; these error codes are an indication of the problem. Refer to the kernel console log (dmesg) for all recent kernel messages from that node. On the node, `/var/log/messages` holds a log of all messages for at least the past day.

The error message initiates with "LustreError" in the console log and provides a short description of:

- What the problem is
- Which process ID had trouble
- Which server node it was communicating with, and so on.

Lustre logs are dumped to the pathname stored in the parameter `lnet.debug_path`.

Collect the first group of messages related to a problem, and any messages that precede "LBUG" or "assertion failure" errors. Messages that mention server nodes (OST or MDS) are specific to that server; you must collect similar messages from the relevant server console logs.

Another Lustre debug log holds information for a short period of time for action by the Lustre software, which, in turn, depends on the processes on the Lustre node. Use the following command to extract debug logs on each of the nodes, run

```
$ lctl dk filename
```

Note

LBUG freezes the thread to allow capture of the panic stack. A system reboot is needed to clear the thread.

35.2. Reporting a Lustre File System Bug

If you cannot resolve a problem by troubleshooting your Lustre file system, other options are:

- Post a question to the lustre-discuss [<http://lists.lustre.org/listinfo.cgi/lustre-discuss-lustre.org>] email list or search the archives for information about your issue.
- Submit a ticket to the Jira [<https://jira.whamcloud.com/>] * bug tracking and project management tool used for the Lustre project. If you are a first-time user, you'll need to open an account by clicking on **Sign up** on the Welcome page.

To submit a Jira ticket, follow these steps:

1. To avoid filing a duplicate ticket, search for existing tickets for your issue. *For search tips, see Section 35.2.1, “Searching Jira* for Duplicate Tickets”.*
2. To create a ticket, click **+Create Issue** in the upper right corner. *Create a separate ticket for each issue you wish to submit.*
3. In the form displayed, enter the following information:
 - *Project* - Select **Lustre** or **Lustre Documentation** or an appropriate project.
 - *Issue type* - Select **Bug**.
 - *Summary* - Enter a short description of the issue. Use terms that would be useful for someone searching for a similar issue. A LustreError or ASSERT/panic message often makes a good summary.
 - *Affects version(s)* - Select your Lustre release.
 - *Environment* - Enter your kernel with version number.
 - *Description* - Include a detailed description of *visible symptoms* and, if possible, *how the problem is produced*. Other useful information may include *the behavior you expect to see* and *what you have tried so far to diagnose the problem*.
 - *Attachments* - Attach log sources such as Lustre debug log dumps (see Section 37.1, “Diagnostic and Debugging Tools”), syslogs, or console logs. **Note:** Lustre debug logs must be processed using `lctl df` prior to attaching to a Jira ticket. For more information, see Section 37.2.2, “Using the lctl Tool to View Debug Messages”.

Other fields in the form are used for project tracking and are irrelevant to reporting an issue. You can leave these in their default state.

35.2.1. Searching Jira* for Duplicate Tickets

Before submitting a ticket, always search the Jira bug tracker for an existing ticket for your issue. This avoids duplicating effort and may immediately provide you with a solution to your problem.

To do a search in the Jira bug tracker, select the **Issues** tab and click on **New filter**. Use the filters provided to select criteria for your search. To search for specific text, enter the text in the "Contains text" field and click the magnifying glass icon.

When searching for text such as an ASSERTION or LustreError message, you can remove NIDs, pointers, and other installation-specific and possibly version-specific text from your search string such as line numbers by following the example below.

Original error message:

```
"(filter_io_26.c: 791:filter_commitrw_write()) ASSERTION(oti-
>oti_transno<=obd->obd_last_committed) failed: oti_transno 752
last_committed 750 "
```

Optimized search string

```
filter_commitrw_write ASSERTION oti_transno obd_last_committed failed:
```

35.3. Common Lustre File System Problems

This section describes how to address common issues encountered with a Lustre file system.

35.3.1. OST Object is Missing or Damaged

If the OSS fails to find an object or finds a damaged object, this message appears:

```
OST object missing or damaged (OST "ost1", object 98148, error -2)
```

If the reported error is -2 (-ENOENT, or "No such file or directory"), then the object is no longer present on the OST, even though a file on the MDT is referencing it. This can occur either because the MDT and OST are out of sync, or because an OST object was corrupted and deleted by e2fsck.

If you have recovered the file system from a disk failure by using e2fsck, then unrecoverable objects may have been deleted or moved to /lost+found in the underlying OST filesystem. Because files on the MDT still reference these objects, attempts to access them produce this error.

If you have restored the filesystem from a backup of the raw MDT or OST partition, then the restored partition is very likely to be out of sync with the rest of your cluster. No matter which server partition you restored from backup, files on the MDT may reference objects which no longer exist (or did not exist when the backup was taken); accessing those files produces this error.

If neither of those descriptions is applicable to your situation, then it is possible that you have discovered a programming error that allowed the servers to get out of sync. Please submit a Jira ticket (see Section 35.2, "Reporting a Lustre File System Bug").

If the reported error is anything else (such as -5, "I/O error"), it likely indicates a storage device failure. The low-level file system returns this error if it is unable to read from the storage device.

Suggested Action

If the reported error is -2, you can consider checking in `lost+found/` on your raw OST device, to see if the missing object is there. However, it is likely that this object is lost forever, and that the file that references the object is now partially or completely lost. Restore this file from backup, or salvage what you can using `dd conv=noerror` and delete it using the `unlink` command.

If the reported error is anything else, then you should immediately inspect this server for storage problems.

35.3.2. OSTs Become Read-Only

If the SCSI devices are inaccessible to the Lustre file system at the block device level, then `ldiskfs` remounts the device read-only to prevent file system corruption. This is a normal behavior. The status in the parameter `health_check` also shows "not healthy" on the affected nodes.

To determine what caused the "not healthy" condition:

- Examine the consoles of all servers for any error indications
- Examine the syslogs of all servers for any `LustreErrors` or `LBUG`
- Check the health of your system hardware and network. (Are the disks working as expected, is the network dropping packets?)
- Consider what was happening on the cluster at the time. Does this relate to a specific user workload or a system load condition? Is the condition reproducible? Does it happen at a specific time (day, week or month)?

To recover from this problem, you must restart Lustre services using these file systems. There is no other way to know that the I/O made it to disk, and the state of the cache may be inconsistent with what is on disk.

35.3.3. Identifying a Missing OST

If an OST is missing for any reason, you may need to know what files are affected. Although an OST is missing, the file system should be operational. From any mounted client node, generate a list of files that reside on the affected OST. It is advisable to mark the missing OST as 'unavailable' so clients and the MDS do not time out trying to contact it.

1. Generate a list of devices and determine the OST's device number. Run:

```
$ lctl dl
```

The `lctl dl` command output lists the device name and number, along with the device UUID and the number of references on the device.

2. Deactivate the OST (on the OSS at the MDS). Run:

```
$ lctl --device lustre_device_number deactivate
```

The OST device number or device name is generated by the `lctl dl` command.

The `deactivate` command prevents clients from creating new objects on the specified OST, although you can still access the OST for reading.

Note

If the OST later becomes available it needs to be reactivated, run:

```
# lctl --device lustre_device_number activate
```

3. Determine all files that are striped over the missing OST, run:

```
# lfs find -O {OST_UUID} /mountpoint
```

This returns a simple list of filenames from the affected file system.

4. If necessary, you can read the valid parts of a striped file, run:

```
# dd if=filename of=new_filename bs=4k conv=sync,noerror
```

5. You can delete these files with the `unlink` command.

```
# unlink filename {filename ...}
```

Note

When you run the `unlink` command, it may return an error that the file could not be found, but the file on the MDS has been permanently removed.

If the file system cannot be mounted, currently there is no way that parses metadata directly from an MDS. If the bad OST does not start, options to mount the file system are to provide a loop device OST in its place or replace it with a newly-formatted OST. In that case, the missing objects are created and are read as zero-filled.

35.3.4. Fixing a Bad LAST_ID on an OST

Each OST contains a LAST_ID file, which holds the last object (pre-)created by the MDS ¹. The MDT contains a lov_objid file, with values that represent the last object the MDS has allocated to a file.

During normal operation, the MDT keeps pre-created (but unused) objects on the OST, and normally LAST_ID should be larger than lov_objid. Any small difference in the values is a result of objects being precreated on the OST to improve MDS file creation performance. These precreated objects are not yet allocated to a file, since they are of zero length (empty).

However, in the case where lov_objid is larger than LAST_ID, it indicates the MDS has allocated objects to files that do not exist on the OST. Conversely, if lov_objid is significantly less than LAST_ID (by at least 20,000 objects) it indicates the OST previously allocated objects at the request of the MDS (which likely contain data) but it doesn't know about them.

Introduced in Lustre 2.5

Since Lustre 2.5 the MDS and OSS will resync the lov_objid and LAST_ID files automatically if they become out of sync. This may result in some space on the OSTs becoming unavailable until LFSCCK is next run, but avoids issues with mounting the filesystem.

Introduced in Lustre 2.6

Since Lustre 2.6 the LFSCCK will repair the LAST_ID file on the OST automatically based on the objects that exist on the OST, in case it was corrupted.

In situations where there is on-disk corruption of the OST, for example caused by the disk write cache being lost, or if the OST was restored from an old backup or reformatted, the LAST_ID value may become inconsistent and result in a message similar to:

```
"myth-OST0002: Too many FIDs to precreate,
OST replaced or reformatted: LFSCCK will clean up"
```

A related situation may happen if there is a significant discrepancy between the record of previously-created objects on the OST and the previously-allocated objects on the MDT, for example if the MDT has been corrupted, or restored from backup, which would cause significant data loss if left unchecked. This produces a message like:

```
"myth-OST0002: too large difference between
MDS LAST_ID [0x1000200000000:0x100048:0x0] (1048648) and
OST LAST_ID [0x1000200000000:0x2232123:0x0] (35856675), trust the OST"
```

In such cases, the MDS will advance the lov_objid value to match that of the OST to avoid deleting existing objects, which may contain data. Files on the MDT that reference these objects will not be lost. Any unreferenced OST objects will be attached to the `.lustre/lost+found` directory the next time LFSCCK layout check is run.

35.3.5. Handling/Debugging "Bind: Address already in use" Error

During startup, the Lustre software may report a `bind: Address already in use` error and reject to start the operation. This is caused by a portmap service (often NFS locking) that starts before the Lustre

¹The contents of the LAST_ID file must be accurate regarding the actual objects that exist on the OST.

file system and binds to the default port 988. You must have port 988 open from firewall or IP tables for incoming connections on the client, OSS, and MDS nodes. LNet will create three outgoing connections on available, reserved ports to each client-server pair, starting with 1023, 1022 and 1021.

Unfortunately, you cannot set `sunrpc` to avoid port 988. If you receive this error, do the following:

- Start the Lustre file system before starting any service that uses `sunrpc`.
- Use a port other than 988 for the Lustre file system. This is configured in `/etc/modprobe.d/lustre.conf` as an option to the LNet module. For example:

```
options lnet accept_port=988
```

- Add `modprobe ptrpc` to your system startup scripts before the service that uses `sunrpc`. This causes the Lustre file system to bind to port 988 and `sunrpc` to select a different port.

Note

You can also use the `sysctl` command to mitigate the NFS client from grabbing the Lustre service port. However, this is a partial workaround as other user-space RPC servers still have the ability to grab the port.

35.3.6. Handling/Debugging Error "- 28"

A Linux error -28 (`ENOSPC`) that occurs during a write or sync operation indicates that an existing file residing on an OST could not be rewritten or updated because the OST was full, or nearly full. To verify if this is the case, run on a client:

```
client$ lfs df -h
UID                               bytes      Used      Available Use% Mounted on
myth-MDT0000_UID                  12.9G      1.5G      10.6G    12% /myth[MDT:0]
myth-OST0000_UID                   3.6T      3.1T      388.9G   89% /myth[OST:0]
myth-OST0001_UID                   3.6T      3.6T        64.0K  100% /myth[OST:1]
myth-OST0002_UID                   3.6T      3.1T      394.6G   89% /myth[OST:2]
myth-OST0003_UID                   5.4T      5.0T      267.8G   95% /myth[OST:3]
myth-OST0004_UID                   5.4T      2.9T       2.2T   57% /myth[OST:4]

filesystem_summary:                21.6T      17.8T       3.2T   85% /myth
```

To address this issue, you can expand the disk space on the OST, or use the `lfs_migrate` command to migrate (move) files to a less full OST. For details on both of these options see Section 14.8, “Adding a New OST to a Lustre File System”

Introduced in Lustre 2.6

In some cases, there may be processes holding files open that are consuming a significant amount of space (e.g. runaway process writing lots of data to an open file that has been deleted). It is possible to get a list of all open file handles in the filesystem from the MDS:

```
mds# lctl get_param mdt.*.exports.*.open_files
mdt.myth-MDT0000.exports.192.168.20.159@tcp.open_files=
[0x200003ab4:0x435:0x0]
[0x20001e863:0x1c1:0x0]
```



```
[0x20001e863:0x1c2:0x0]
:
```

These file handles can be converted into pathnames on any client via the `lfs fid2path` command (as root):

```
client# lfs fid2path /myth [0x200003ab4:0x435:0x0] [0x20001e863:0x1c1:0x0] [0x2000
lfs fid2path: cannot find '[0x200003ab4:0x435:0x0]': No such file or directory
/myth/tmp/4M
/myth/tmp/1G
:
```

In some cases, if the file has been deleted from the filesystem, `fid2path` will return an error that the file is not found. You can use the client NID (`192.168.20.159@tcp` in the above example) to determine which node the file is open on, and `lsof` to find and kill the process that is holding the file open:

```
# lsof /myth
COMMAND  PID  USER  FD  TYPE  DEVICE  SIZE/OFF  NODE NAME
logger  13806  mythtv  0r  REG  35,632494 1901048576384 144115440203858997 /myth/log
```

A Linux error -28 (ENOSPC) that occurs when a new file is being created may indicate that the MDT has run out of inodes and needs to be made larger. Newly created files are not written to full OSTs, while existing files continue to reside on the OST where they were initially created. To view inode information on the MDT, run on a client:

```
lfs df -i
UUID          Inodes      IUsed      IFree  IUse%  Mounted on
myth-MDT0000_UUID  1910263    1910263         0 100% /myth[MDT:0]
myth-OST0000_UUID  947456     360059    587397  89% /myth[OST:0]
myth-OST0001_UUID  948864     233748    715116  91% /myth[OST:1]
myth-OST0002_UUID  947456     549961    397495  89% /myth[OST:2]
myth-OST0003_UUID  1426144    477595    948549  95% /myth[OST:3]
myth-OST0004_UUID  1426080    465248    1420832 57% /myth[OST:4]

filesystem_summary:  1910263    1910263         0 100% /myth
```

Typically, the Lustre software reports this error to your application. If the application is checking the return code from its function calls, then it decodes it into a textual error message such as `No space left on device`. The numeric error message may also appear in the system log.

For more information about the `lfs df` command, see Section 19.8.1, “Checking File System Free Space”.

You can also use the `lctl get_param` command to monitor the space and object usage on the OSTs and MDTs from any client:

```
lctl get_param {osc,mdc}.*.{kbytes,files}{free,avail,total}
```

Note

You can find other numeric error codes along with a short name and text description in `/usr/include/asm/errno.h`.

35.3.7. Triggering Watchdog for PID NNN

In some cases, a server node triggers a watchdog timer and this causes a process stack to be dumped to the console along with a Lustre kernel debug log being dumped into `/tmp` (by default). The presence of a watchdog timer does NOT mean that the thread OOPSed, but rather that it is taking longer time than expected to complete a given operation. In some cases, this situation is expected.

For example, if a RAID rebuild is really slowing down I/O on an OST, it might trigger watchdog timers to trip. But another message follows shortly thereafter, indicating that the thread in question has completed processing (after some number of seconds). Generally, this indicates a transient problem. In other cases, it may legitimately signal that a thread is stuck because of a software error (lock inversion, for example).

```
Lustre: 0:0:(watchdog.c:122:lcw_cb())
```

The above message indicates that the watchdog is active for pid 933:

It was inactive for 100000ms:

```
Lustre: 0:0:(linux-debug.c:132:portals_debug_dumpstack())
```

Showing stack for process:

```
933 ll_ost_25      D F896071A      0   933      1   934   932 (L-TLB)
f6d87c60 00000046 00000000 f896071a f8def7cc 00002710 00001822 2da48cae
0008cf1a f6d7c220 f6d7c3d0 f6d86000 f3529648 f6d87cc4 f3529640 f8961d3d
00000010 f6d87c9c ca65a13c 00001fff 00000001 00000001 00000000 00000001
```

Call trace:

```
filter_do_bio+0x3dd/0xb90 [obdfilter]
default_wake_function+0x0/0x20
filter_direct_io+0x2fb/0x990 [obdfilter]
filter_preprw_read+0x5c5/0xe00 [obdfilter]
lustre_swab_niobuf_remote+0x0/0x30 [ptlrpc]
ost_brw_read+0x18df/0x2400 [ost]
ost_handle+0x14c2/0x42d0 [ost]
ptlrpc_server_handle_request+0x870/0x10b0 [ptlrpc]
ptlrpc_main+0x42e/0x7c0 [ptlrpc]
```

35.3.8. Handling Timeouts on Initial Lustre File System Setup

If you come across timeouts or hangs on the initial setup of your Lustre file system, verify that name resolution for servers and clients is working correctly. Some distributions configure `/etc/hosts` so the name of the local machine (as reported by the `'hostname'` command) is mapped to local host (127.0.0.1) instead of a proper IP address.

This might produce this error:

```
LustreError:(ldlm_handle_cancel()) received cancel for unknown lock cookie
0xe74021a4b41b954e from nid 0x7f000001 (0:127.0.0.1)
```

35.3.9. Handling/Debugging "LustreError: xxx went back in time"

Each time the MDS or OSS modifies the state of the MDT or OST disk filesystem for a client, it records a per-target increasing transaction number for the operation and returns it to the client along with the reply to that operation. Periodically, when the server commits these transactions to disk, the `last_committed` transaction number is returned to the client to allow it to discard pending operations from memory, as they will no longer be needed for recovery in case of server failure.

In some cases error messages similar to the following have been observed after a server was restarted or failed over:

```
LustreError: 3769:0:(import.c:517:ptlrpc_connect_interpret())
testfs-ost12_UUID went back in time (transno 831 was previously committed,
server now claims 791)!
```

This situation arises when:

- You are using a disk device that claims to have data written to disk before it actually does, as in case of a device with a large cache. If that disk device crashes or loses power in a way that causes the loss of the cache, there can be a loss of transactions that you believe are committed. This is a very serious event, and you should run `e2fsck` against that storage before restarting the Lustre file system.
- As required by the Lustre software, the shared storage used for failover is completely cache-coherent. This ensures that if one server takes over for another, it sees the most up-to-date and accurate copy of the data. In case of the failover of the server, if the shared storage does not provide cache coherency between all of its ports, then the Lustre software can produce an error.

If you know the exact reason for the error, then it is safe to proceed with no further action. If you do not know the reason, then this is a serious issue and you should explore it with your disk vendor.

If the error occurs during failover, examine your disk cache settings. If it occurs after a restart without failover, try to determine how the disk can report that a write succeeded, then lose the Data Device corruption or Disk Errors.

35.3.10. Lustre Error: "slow_start_page_write"

The `slow_start_page_write` message appears when the operation takes an extremely long time to allocate a batch of memory pages. Use these pages to receive network traffic first, and then write to disk.

35.3.11. Drawbacks in Doing Multi-client O_APPEND Writes

It is possible to do multi-client `O_APPEND` writes to a single file, but there are few drawbacks that may make this a sub-optimal solution. These drawbacks are:

- Each client needs to take an EOF lock on all the OSTs, as it is difficult to know which OST holds the end of the file until you check all the OSTs. As all the clients are using the same `O_APPEND`, there is significant locking overhead.
- The second client cannot get all locks until the end of the writing of the first client, as the taking serializes all writes from the clients.
- To avoid deadlocks, the taking of these locks occurs in a known, consistent order. As a client cannot know which OST holds the next piece of the file until the client has locks on all OSTs, there is a need of these locks in case of a striped file.

35.3.12. Slowdown Occurs During Lustre File System Startup

When a Lustre file system starts, it needs to read in data from the disk. For the very first `mdsrate` run after the reboot, the MDS needs to wait on all the OSTs for object pre-creation. This causes a slowdown to occur when the file system starts up.

After the file system has been running for some time, it contains more data in cache and hence, the variability caused by reading critical metadata from disk is mostly eliminated. The file system now reads data from the cache.

35.3.13. Log Message 'Out of Memory' on OST

When planning the hardware for an OSS node, consider the memory usage of several components in the Lustre file system. If insufficient memory is available, an 'out of memory' message can be logged.

During normal operation, several conditions indicate insufficient RAM on a server node:

- kernel "Out of memory" and/or "oom-killer" messages
- Lustre "kmallocc of 'mmm' (NNNN bytes) failed..." messages
- Lustre or kernel stack traces showing processes stuck in "try_to_free_pages"

For information on determining the MDS memory and OSS memory requirements, see Section 5.5, "Determining Memory Requirements".

35.3.14. Setting SCSI I/O Sizes

Some SCSI drivers default to a maximum I/O size that is too small for good Lustre file system performance. We have fixed quite a few drivers, but you may still find that some drivers give unsatisfactory performance with the Lustre file system. As the default value is hard-coded, you need to recompile the drivers to change their default. On the other hand, some drivers may have a wrong default set.

If you suspect bad I/O performance and an analysis of Lustre file system statistics indicates that I/O is not 1 MB, check `/sys/block/device/queue/max_sectors_kb`. If the `max_sectors_kb` value is less than 1024, set it to at least 1024 to improve performance. If changing `max_sectors_kb` does not change the I/O size as reported by the Lustre software, you may want to examine the SCSI driver code.

Chapter 36. Troubleshooting Recovery

This chapter describes what to do if something goes wrong during recovery. It describes:

- Section 36.1, “Recovering from Errors or Corruption on a Backing `ldiskfs` File System”
- Section 36.2, “Recovering from Corruption in the Lustre File System”
- Section 36.3, “Recovering from an Unavailable OST”
- Section 36.4, “Checking the file system with `LFSCK`”

36.1. Recovering from Errors or Corruption on a Backing `ldiskfs` File System

When an OSS, MDS, or MGS server crash occurs, it is not necessary to run `e2fsck` on the file system. `ldiskfs` journaling ensures that the file system remains consistent over a system crash. The backing file systems are never accessed directly from the client, so client crashes are not relevant for server file system consistency.

The only time it is **REQUIRED** that `e2fsck` be run on a device is when an event causes problems that `ldiskfs` journaling is unable to handle, such as a hardware device failure or I/O error. If the `ldiskfs` kernel code detects corruption on the disk, it mounts the file system as read-only to prevent further corruption, but still allows read access to the device. This appears as error “-30” (`EROFS`) in the syslogs on the server, e.g.:

```
Dec 29 14:11:32 mookie kernel: LDISKFS-fs error (device sdz):  
        ldiskfs_lookup: unlinked inode 5384166 in dir #145170469  
Dec 29 14:11:32 mookie kernel: Remounting filesystem read-only
```

In such a situation, it is normally required that `e2fsck` only be run on the bad device before placing the device back into service.

In the vast majority of cases, the Lustre software can cope with any inconsistencies found on the disk and between other devices in the file system.

For problem analysis, it is strongly recommended that `e2fsck` be run under a logger, like `script`, to record all of the output and changes that are made to the file system in case this information is needed later.

If time permits, it is also a good idea to first run `e2fsck` in non-fixing mode (`-n` option) to assess the type and extent of damage to the file system. The drawback is that in this mode, `e2fsck` does not recover the file system journal, so there may appear to be file system corruption when none really exists.

To address concern about whether corruption is real or only due to the journal not being replayed, you can briefly mount and unmount the `ldiskfs` file system directly on the node with the Lustre file system stopped, using a command similar to:

```
mount -t ldiskfs /dev/{ostdev} /mnt/ost; umount /mnt/ost
```

This causes the journal to be recovered.

The `e2fsck` utility works well when fixing file system corruption (better than similar file system recovery tools and a primary reason why `ldiskfs` was chosen over other file systems). However, it is often useful

to identify the type of damage that has occurred so an `ldiskfs` expert can make intelligent decisions about what needs fixing, in place of `e2fsck`.

```
root# {stop lustre services for this device, if running}
root# script /tmp/e2fsck.sda
Script started, file is /tmp/e2fsck.sda
root# mount -t ldiskfs /dev/sda /mnt/ost
root# umount /mnt/ost
root# e2fsck -fn /dev/sda # don't fix file system, just check for corruption
:
[e2fsck output]
:
root# e2fsck -fp /dev/sda # fix errors with prudent answers (usually yes)
```

36.2. Recovering from Corruption in the Lustre File System

In cases where an `ldiskfs` MDT or OST becomes corrupt, you need to run `e2fsck` to ensure local filesystem consistency, then use `LFSCK` to run a distributed check on the file system to resolve any inconsistencies between the MDTs and OSTs, or among MDTs.

1. Stop the Lustre file system.
2. Run `e2fsck -f` on the individual MDT/OST that had problems to fix any local file system damage.

We recommend running `e2fsck` under `script`, to create a log of changes made to the file system in case it is needed later. After `e2fsck` is run, bring up the file system, if necessary, to reduce the outage window.

36.2.1. Working with Orphaned Objects

The simplest problem to resolve is that of orphaned objects. When the `LFSCK` layout check is run, these objects are linked to new files and put into `.lustre/lost+found/MDTxxxx` in the Lustre file system (where `MDTxxxx` is the index of the MDT on which the orphan was found), where they can be examined and saved or deleted as necessary.

Introduced in Lustre 2.7

With Lustre version 2.7 and later, `LFSCK` will identify and process orphan objects found on MDTs as well.

36.3. Recovering from an Unavailable OST

One problem encountered in a Lustre file system environment is when an OST becomes unavailable due to a network partition, OSS node crash, etc. When this happens, the OST's clients pause and wait for the OST to become available again, either on the primary OSS or a failover OSS. When the OST comes back online, the Lustre file system starts a recovery process to enable clients to reconnect to the OST. Lustre servers put a limit on the time they will wait in recovery for clients to reconnect.

During recovery, clients reconnect and replay their requests serially, in the same order they were done originally. Until a client receives a confirmation that a given transaction has been written to stable storage, the client holds on to the transaction, in case it needs to be replayed. Periodically, a progress message prints to the log, stating how `_many/expected` clients have reconnected. If the recovery is aborted, this log shows

how many clients managed to reconnect. When all clients have completed recovery, or if the recovery timeout is reached, the recovery period ends and the OST resumes normal request processing.

If some clients fail to replay their requests during the recovery period, this will not stop the recovery from completing. You may have a situation where the OST recovers, but some clients are not able to participate in recovery (e.g. network problems or client failure), so they are evicted and their requests are not replayed. This would result in any operations on the evicted clients failing, including in-progress writes, which would cause cached writes to be lost. This is a normal outcome; the recovery cannot wait indefinitely, or the file system would be hung any time a client failed. The lost transactions are an unfortunate result of the recovery process.

Note

The failure of client recovery does not indicate or lead to filesystem corruption. This is a normal event that is handled by the MDT and OST, and should not result in any inconsistencies between servers.

Note

The version-based recovery (VBR) feature enables a failed client to be "skipped", so remaining clients can replay their requests, resulting in a more successful recovery from a downed OST. For more information about the VBR feature, see Chapter 38, *Lustre File System Recovery*(Version-based Recovery).

36.4. Checking the file system with LFSCK

LFSCK is an administrative tool for checking and repair of the attributes specific to a mounted Lustre file system. It is similar in concept to an offline fsck repair tool for a local filesystem, but LFSCK is implemented to run as part of the Lustre file system while the file system is mounted and in use. This allows consistency checking and repair of Lustre-specific metadata without unnecessary downtime, and can be run on the largest Lustre file systems with minimal impact to normal operations.

LFSCK can verify and repair the Object Index (OI) table that is used internally to map Lustre File Identifiers (FIDs) to MDT internal ldiskfs inode numbers, in an internal table called the OI Table. An OI Scrub traverses the OI table and makes corrections where necessary. An OI Scrub is required after restoring from a file-level MDT backup (Section 18.2, “ Backing Up and Restoring an MDT or OST (ldiskfs Device Level)”), or in case the OI Table is otherwise corrupted. Later phases of LFSCK will add further checks to the Lustre distributed file system state. LFSCK namespace scanning can verify and repair the directory FID-in-dirent and LinKEA consistency.

Introduced in Lustre 2.6

In Lustre software release 2.6, LFSCK layout scanning can verify and repair MDT-OST file layout inconsistencies. File layout inconsistencies between MDT-objects and OST-objects that are checked and corrected include dangling reference, unreferenced OST-objects, mismatched references and multiple references.

Introduced in Lustre 2.7

In Lustre software release 2.7, LFSCK layout scanning is enhanced to support verify and repair inconsistencies between multiple MDTs.

Control and monitoring of LFSCK is through LFSCK and the `lctl get_param` command. LFSCK supports three types of interface: switch interface, status interface, and adjustment interface. These interfaces are detailed below.

36.4.1. LFSCK switch interface

36.4.1.1. Manually Starting LFSCK

36.4.1.1.1. Description

LFSCK can be started after the MDT is mounted using the `lctl lfsck_start` command.

36.4.1.1.2. Usage

```
lctl lfsck_start <-M | --device [MDT,OST]_device> \
    [-A | --all] \
    [-c | --create_ostobj on | off] \
    [-C | --create_mdtojb on | off] \
    [-d | --delay_create_ostobj on | off] \
    [-e | --error {continue | abort}] \
    [-h | --help] \
    [-n | --dryrun on | off] \
    [-o | --orphan] \
    [-r | --reset] \
    [-s | --speed ops_per_sec_limit] \
    [-t | --type check_type[,check_type...]] \
    [-w | --window_size size]
```

36.4.1.1.3. Options

The various `lfsck_start` options are listed and described below. For a complete list of available options, type `lctl lfsck_start -h`.

Option	Description
<code>-M --device</code>	The MDT or OST target to start LFSCK on.
<code>-A --all</code>	Introduced in Lustre 2.6 Start LFSCK on all targets on all servers simultaneously. By default, both layout and namespace consistency checking and repair are started.
<code>-c --create_ostobj</code>	Introduced in Lustre 2.6 Create the lost OST-object for dangling LOV EA, <code>off</code> (default) or <code>on</code> . If not specified, then the default behaviour is to keep the dangling LOV EA there without creating the lost OST-object.
<code>-C --create_mdtojb</code>	Introduced in Lustre 2.7 Create the lost MDT-object for dangling name entry, <code>off</code> (default) or <code>on</code> . If not specified, then the default behaviour is to keep the dangling name entry there without creating the lost MDT-object.
<code>-d --delay_create_ostobj</code>	Introduced in Lustre 2.9 Delay creating the lost OST-object for dangling LOV EA until the orphan OST-objects are handled. <code>off</code> (default) or <code>on</code> .

Option	Description
-e --error	Error handle, <code>continue</code> (default) or <code>abort</code> . Specify whether the LFSCK will stop or not if fails to repair something. If it is not specified, the saved value (when resuming from checkpoint) will be used if present. This option cannot be changed while LFSCK is running.
-h --help	Operating help information.
-n --dryrun	Perform a trial without making any changes. <code>off</code> (default) or <code>on</code> .
-o --orphan	<p>Introduced in Lustre 2.6</p> <p>Repair orphan OST-objects for layout LFSCK.</p>
-r --reset	Reset the start position for the object iteration to the beginning for the specified MDT. By default the iterator will resume scanning from the last checkpoint (saved periodically by LFSCK) provided it is available.
-s --speed	Set the upper speed limit of LFSCK processing in objects per second. If it is not specified, the saved value (when resuming from checkpoint) or default value of 0 (0 = run as fast as possible) is used. Speed can be adjusted while LFSCK is running with the adjustment interface.
-t --type	<p>The type of checking/repairing that should be performed. The new LFSCK framework provides a single interface for a variety of system consistency checking/repairing operations including:</p> <p>Without a specified option, the LFSCK component(s) which ran last time and did not finish or the component(s) corresponding to some known system inconsistency, will be started. Anytime the LFSCK is triggered, the OI scrub will run automatically, so there is no need to specify <code>OI_scrub</code> in that case.</p> <p>namespace: check and repair FID-in-dirent and LinEA consistency.</p> <p>Introduced in Lustre 2.7</p> <p>Lustre-2.7 enhances namespace consistency verification under DNE mode.</p> <p>Introduced in Lustre 2.6</p> <p>layout: check and repair MDT-OST inconsistency.</p>
-w --window_size	<p>Introduced in Lustre 2.6</p> <p>The window size for the async request pipeline. The LFSCK async request pipeline's input/output may have quite different processing speeds, and there may be too many requests in the pipeline as to cause abnormal memory/network pressure. If not specified, then the default window size for the async request pipeline is 1024.</p>

36.4.1.2. Manually Stopping LFSCCK

36.4.1.2.1. Description

To stop LFSCCK when the MDT is mounted, use the `lctl lfsck_stop` command.

36.4.1.2.2. Usage

```
lctl lfsck_stop <-M | --device [MDT,OST]_device> \
    [-A | --all] \
    [-h | --help]
```

36.4.1.2.3. Options

The various `lfsck_stop` options are listed and described below. For a complete list of available options, type `lctl lfsck_stop -h`.

Option	Description
-M --device	The MDT or OST target to stop LFSCCK on.
-A --all	Stop LFSCCK on all targets on all servers simultaneously.
-h --help	Operating help information.

Introduced in Lustre 2.9

36.4.2. Check the LFSCCK global status

36.4.2.1. Description

Check the LFSCCK global status via a single `lctl lfsck_query` command on the MDS.

36.4.2.2. Usage

```
lctl lfsck_query <-M | --device MDT_device> \
    [-h | --help] \
    [-t | --type lfsck_type[,lfsck_type...]] \
    [-w | --wait]
```

36.4.2.3. Options

The various `lfsck_query` options are listed and described below. For a complete list of available options, type `lctl lfsck_query -h`.

Option	Description
-M --device	The device to query for LFSCCK status.
-h --help	Operating help information.
-t --type	The LFSCCK type(s) that should be queried, including: layout, namespace.
-w --wait	will wait if the LFSCCK is in scanning.

36.4.3. LFSCK status interface

36.4.3.1. LFSCK status of OI Scrub via `procf s`

36.4.3.1.1. Description

For each LFSCK component there is a dedicated `procf s` interface to trace the corresponding LFSCK component status. For OI Scrub, the interface is the OSD layer `procf s` interface, named `oi_scrub`. To display OI Scrub status, the standard `lctl get_param` command is used as shown in the usage below.

36.4.3.1.2. Usage

```
lctl get_param -n osd-ldiskfs.FSNAME-[MDT_target/OST_target].oi_scrub
```

36.4.3.1.3. Output

Information	Detail
General Information	<ul style="list-style-type: none"> • Name: <code>OI_scrub</code>. • OI scrub magic id (an identifier unique to OI scrub). • OI files count. • Status: one of the status - <code>init</code>, <code>scanning</code>, <code>completed</code>, <code>failed</code>, <code>stopped</code>, <code>paused</code>, or <code>crashed</code>. • Flags: including - <code>recreated</code>(OI file(s) is/are removed/recreated), <code>inconsistent</code>(restored from file-level backup), <code>auto</code>(triggered by non-UI mechanism), and <code>upgrade</code>(from Lustre software release 1.8 IGIF format.) • Parameters: OI scrub parameters, like <code>failout</code>. • Time Since Last Completed. • Time Since Latest Start. • Time Since Last Checkpoint. • Latest Start Position: the position for the latest scrub started from. • Last Checkpoint Position. • First Failure Position: the position for the first object to be repaired. • Current Position.
Statistics	<ul style="list-style-type: none"> • Checked total number of objects scanned. • Updated total number of objects repaired. • Failed total number of objects that failed to be repaired. • No <code>Scrub</code> total number of objects marked <code>LDISKFS_STATE_LUSTRE_NOSCRUB</code> and skipped.

Information	Detail
	<ul style="list-style-type: none"> • IGIF total number of objects IGIF scanned. • Prior Updated how many objects have been repaired which are triggered by parallel RPC. • Success Count total number of completed OI_scrub runs on the target. • Run Time how long the scrub has run, tally from the time of scanning from the beginning of the specified MDT target, not include the paused/failure time among checkpoints. • Average Speed calculated by dividing Checked by run_time. • Real-Time Speed the speed since last checkpoint if the OI_scrub is running. • Scanned total number of objects under /lost+found that have been scanned. • Repaired total number of objects under /lost+found that have been recovered. • Failed total number of objects under /lost+found failed to be scanned or failed to be recovered.

36.4.3.2. LFSCK status of namespace via `procf`s

36.4.3.2.1. Description

The namespace component is responsible for checks described in Section 36.4, “Checking the file system with LFSCK”. The `procf`s interface for this component is in the MDD layer, named `lfscck_namespace`. To show the status of this component, `lctl get_param` should be used as described in the usage below.

The LFSCK namespace status output refers to phase 1 and phase 2. Phase 1 is when the LFSCK main engine, which runs on each MDT, linearly scans its local device, guaranteeing that all local objects are checked. However, there are certain cases in which LFSCK cannot know whether an object is consistent or cannot repair an inconsistency until the phase 1 scanning is completed. During phase 2 of the namespace check, objects with multiple hard-links, objects with remote parents, and other objects which couldn't be verified during phase 1 will be checked.

36.4.3.2.2. Usage

```
lctl get_param -n mdd. FSNAME-MDT_target.lfscck_namespace
```

36.4.3.2.3. Output

Information	Detail
General Information	<ul style="list-style-type: none"> • Name: <code>lfscck_namespace</code> • LFSCK namespace magic. • LFSCK namespace version..

Information	Detail
	<ul style="list-style-type: none"> • Status: one of the status - <code>init</code>, <code>scanning-phase1</code>, <code>scanning-phase2</code>, <code>completed</code>, <code>failed</code>, <code>stopped</code>, <code>paused</code>, <code>partial</code>, <code>co-failed</code>, <code>co-stopped</code> or <code>co-paused</code>. • Flags: including - <code>scanned-once</code>(the first cycle scanning has been completed), <code>inconsistent</code>(one or more inconsistent FID-in-dirent or LinkEA entries that have been discovered), <code>upgrade</code>(from Lustre software release 1.8 IGIF format.) • Parameters: including <code>dryrun</code>, <code>all_targets</code>, <code>failout</code>, <code>broadcast</code>, <code>orphan</code>, <code>create_ostobj</code> and <code>create_mdtoobj</code>. • Time Since Last Completed. • Time Since Latest Start. • Time Since Last Checkpoint. • Latest Start Position: the position the checking began most recently. • Last Checkpoint Position. • First Failure Position: the position for the first object to be repaired. • Current Position.
Statistics	<ul style="list-style-type: none"> • <code>Checked Phase1</code> total number of objects scanned during <code>scanning-phase1</code>. • <code>Checked Phase2</code> total number of objects scanned during <code>scanning-phase2</code>. • <code>Updated Phase1</code> total number of objects repaired during <code>scanning-phase1</code>. • <code>Updated Phase2</code> total number of objects repaired during <code>scanning-phase2</code>. • <code>Failed Phase1</code> total number of objects that failed to be repaired during <code>scanning-phase1</code>. • <code>Failed Phase2</code> total number of objects that failed to be repaired during <code>scanning-phase2</code>. • <code>directories</code> total number of directories scanned. • <code>multiple_linked_checked</code> total number of multiple-linked objects that have been scanned. • <code>dirent_repaired</code> total number of FID-in-dirent entries that have been repaired. • <code>linkea_repaired</code> total number of linkEA entries that have been repaired.

Information	Detail
	<ul style="list-style-type: none"> • <code>unknown_inconsistency</code> total number of undefined inconsistencies found in scanning-phase2. • <code>unmatched_pairs_repaired</code> total number of unmatched pairs that have been repaired. • <code>dangling_repaired</code> total number of dangling name entries that have been found/repaired. • <code>multi_referenced_repaired</code> total number of multiple referenced name entries that have been found/repaired. • <code>bad_file_type_repaired</code> total number of name entries with bad file type that have been repaired. • <code>lost_dirent_repaired</code> total number of lost name entries that have been re-inserted. • <code>striped_dirs_scanned</code> total number of striped directories (master) that have been scanned. • <code>striped_dirs_repaired</code> total number of striped directories (master) that have been repaired. • <code>striped_dirs_failed</code> total number of striped directories (master) that have failed to be verified. • <code>striped_dirs_disabled</code> total number of striped directories (master) that have been disabled. • <code>striped_dirs_skipped</code> total number of striped directories (master) that have been skipped (for shards verification) because of lost master LMV EA. • <code>striped_shards_scanned</code> total number of striped directory shards (slave) that have been scanned. • <code>striped_shards_repaired</code> total number of striped directory shards (slave) that have been repaired. • <code>striped_shards_failed</code> total number of striped directory shards (slave) that have failed to be verified. • <code>striped_shards_skipped</code> total number of striped directory shards (slave) that have been skipped (for name hash verification) because LFSCK does not know whether the slave LMV EA is valid or not. • <code>name_hash_repaired</code> total number of name entries under striped directory with bad name hash that have been repaired. • <code>nlinks_repaired</code> total number of objects with nlink fixed. • <code>mul_linked_repaired</code> total number of multiple-linked objects that have been repaired.

Information	Detail
	<ul style="list-style-type: none"> • <code>local_lost_found_scanned</code> total number of objects under <code>/lost+found</code> that have been scanned. • <code>local_lost_found_moved</code> total number of objects under <code>/lost+found</code> that have been moved to namespace visible directory. • <code>local_lost_found_skipped</code> total number of objects under <code>/lost+found</code> that have been skipped. • <code>local_lost_found_failed</code> total number of objects under <code>/lost+found</code> that have failed to be processed. • <code>Success Count</code> the total number of completed LFSCCK runs on the target. • <code>Run Time Phase1</code> the duration of the LFSCCK run during <code>scanning-phase1</code>. Excluding the time spent paused between checkpoints. • <code>Run Time Phase2</code> the duration of the LFSCCK run during <code>scanning-phase2</code>. Excluding the time spent paused between checkpoints. • <code>Average Speed Phase1</code> calculated by dividing <code>checked_phase1</code> by <code>run_time_phase1</code>. • <code>Average Speed Phase2</code> calculated by dividing <code>checked_phase2</code> by <code>run_time_phase1</code>. • <code>Real-Time Speed Phase1</code> the speed since the last checkpoint if the LFSCCK is running <code>scanning-phase1</code>. • <code>Real-Time Speed Phase2</code> the speed since the last checkpoint if the LFSCCK is running <code>scanning-phase2</code>.

Introduced in Lustre 2.6

36.4.3.3. LFSCCK status of layout via `procf`s

36.4.3.3.1. Description

The `layout` component is responsible for checking and repairing MDT-OST inconsistency. The `procf`s interface for this component is in the MDD layer, named `lfscck_layout`, and in the OBD layer, named `lfscck_layout`. To show the status of this component `lctl get_param` should be used as described in the usage below.

The LFSCCK layout status output refers to phase 1 and phase 2. Phase 1 is when the LFSCCK main engine, which runs on each MDT/OST, linearly scans its local device, guaranteeing that all local objects are checked. During phase 1 of layout LFSCCK, the OST-objects which are not referenced by any MDT-object are recorded in a bitmap. During phase 2 of the layout check, the OST-objects in the bitmap will be re-scanned to check whether they are really orphan objects.

36.4.3.3.2. Usage

```
lctl get_param -n mdd.
```

```
FSNAME-
MDT_target.lfsck_layout
lctl get_param -n obdfilter.
FSNAME-
OST_target.lfsck_layout
```

36.4.3.3.3. Output

Information	Detail
General Information	<ul style="list-style-type: none"> • Name: lfsck_layout • LFSCK namespace magic. • LFSCK namespace version.. • Status: one of the status - init, scanning-phase1, scanning-phase2, completed, failed, stopped, paused, crashed, partial, co-failed, co-stopped, or co-paused. • Flags: including - scanned-once(the first cycle scanning has been completed), inconsistent(one or more MDT-OST inconsistencies have been discovered), incomplete(some MDT or OST did not participate in the LFSCK or failed to finish the LFSCK) or crashed_lastid(the lastid files on the OST crashed and needs to be rebuilt). • Parameters: including dryrun, all_targets and failout. • Time Since Last Completed. • Time Since Latest Start. • Time Since Last Checkpoint. • Latest Start Position: the position the checking began most recently. • Last Checkpoint Position. • First Failure Position: the position for the first object to be repaired. • Current Position.
Statistics	<ul style="list-style-type: none"> • Success Count : the total number of completed LFSCK runs on the target. • Repaired Dangling : total number of MDT-objects with dangling reference have been repaired in the scanning-phase1. • Repaired Unmatched Pairs total number of unmatched MDT and OST-object pairs have been repaired in the scanning-phase1 • Repaired Multiple Referenced total number of OST-objects with multiple reference have been repaired in the scanning-phase1. • Repaired Orphan total number of orphan OST-objects have been repaired in the scanning-phase2.

Information	Detail
	<ul style="list-style-type: none"> • Repaired Inconsistent Owner total number.of OST-objects with incorrect owner information have been repaired in the scanning-phase1. • Repaired Others total number of.other inconsistency repaired in the scanning phases. • Skipped Number of skipped objects. • Failed Phase1 total number of objects that failed to be repaired during scanning-phase1. • Failed Phase2 total number of objects that failed to be repaired during scanning-phase2. • Checked Phase1 total number of objects scanned during scanning-phase1. • Checked Phase2 total number of objects scanned during scanning-phase2. • Run Time Phase1 the duration of the LFSCCK run during scanning-phase1. Excluding the time spent paused between checkpoints. • Run Time Phase2 the duration of the LFSCCK run during scanning-phase2. Excluding the time spent paused between checkpoints. • Average Speed Phase1 calculated by dividing checked_phase1 by run_time_phase1. • Average Speed Phase2 calculated by dividing checked_phase2 by run_time_phase1. • Real-Time Speed Phase1 the speed since the last checkpoint if the LFSCCK is running scanning-phase1. • Real-Time Speed Phase2 the speed since the last checkpoint if the LFSCCK is running scanning-phase2.

36.4.4. LFSCCK adjustment interface

Introduced in Lustre 2.6

36.4.4.1. Rate control

36.4.4.1.1. Description

The LFSCCK upper speed limit can be changed using `lctl set_param` as shown in the usage below.

36.4.4.1.2. Usage

```
lctl set_param mdd.${FSNAME}-${MDT_target}.lfscck_speed_limit=
```

```
N
lctl set_param obdfilter.${FSNAME}-${OST_target}.lfsck_speed_limit=
N
```

36.4.4.1.3. Values

0	No speed limit (run at maximum speed.)
positive integer	Maximum number of objects to scan per second.

36.4.4.2. Auto scrub

36.4.4.2.1. Description

The `auto_scrub` parameter controls whether OI scrub will be triggered when an inconsistency is detected during OI lookup. It can be set as described in the usage and values sections below.

There is also a `noscrub` mount option (see Section 44.13, “`mount.lustre`”) which can be used to disable automatic OI scrub upon detection of a file-level backup at mount time. If the `noscrub` mount option is specified, `auto_scrub` will also be disabled, so OI scrub will not be triggered when an OI inconsistency is detected. Auto scrub can be reenabled after the mount using the command shown in the usage. Manually starting LFSCCK after mounting provides finer control over the starting conditions.

36.4.4.2.2. Usage

```
lctl set_param osd_ldiskfs.${FSNAME}-${MDT_target}.auto_scrub=N
```

where *N* is an integer as described below.

Introduced in Lustre 2.5

Note

Lustre software 2.5 and later supports `-P` option that makes the `set_param` permanent.

36.4.4.2.3. Values

0	Do not start OI Scrub automatically.
positive integer	Automatically start OI Scrub if inconsistency is detected during OI lookup.

Chapter 37. Debugging a Lustre File System

This chapter describes tips and information to debug a Lustre file system, and includes the following sections:

- Section 37.1, “Diagnostic and Debugging Tools”
- Section 37.2, “Lustre Debugging Procedures”
- Section 37.3, “Lustre Debugging for Developers”

37.1. Diagnostic and Debugging Tools

A variety of diagnostic and analysis tools are available to debug issues with the Lustre software. Some of these are provided in Linux distributions, while others have been developed and are made available by the Lustre project.

37.1.1. Lustre Debugging Tools

The following in-kernel debug mechanisms are incorporated into the Lustre software:

- **Debug logs** - A circular debug buffer to which Lustre internal debug messages are written (in contrast to error messages, which are printed to the syslog or console). Entries in the Lustre debug log are controlled by a mask set by `lctl set_param debug=mask`. The log size defaults to 5 MB per CPU but can be increased as a busy system will quickly overwrite 5 MB. When the buffer fills, the oldest log records are discarded.
- `lctl get_param debug` - This shows the current debug mask used to delimit the debugging information written out to the kernel debug logs.
- `lctl debug_kernel file` - Dump the Lustre kernel debug log to the specified file as ASCII text for further debugging and analysis.
- `lctl set_param debug_mb=size` - This sets the maximum size of the in-kernel Lustre debug buffer, in units of MiB.
- **Debug daemon** - The debug daemon controls the continuous logging of debug messages to a log file in userspace.

The following tools are also provided with the Lustre software:

- `lctl` - This tool is used with the `debug_kernel` option to manually dump the Lustre debugging log or post-process debugging logs that are dumped automatically. For more information about the `lctl` tool, see Section 37.2.2, “Using the `lctl` Tool to View Debug Messages” and Section 44.2, “`lctl`”.
- **Lustre subsystem asserts** - A panic-style assertion (LBUG) in the kernel causes the Lustre file system to dump the debug log to the file `/tmp/lustre-log.timestamp` where it can be retrieved after a reboot. For more information, see Section 35.1.2, “Viewing Error Messages”.
- `lfs` - This utility provides access to the layout of of a Lustre file, along with other information relevant to users. For more information about `lfs`, see Section 40.1, “`lfs`”.

37.1.2. External Debugging Tools

The tools described in this section are provided in the Linux kernel or are available at an external website. For information about using some of these tools for Lustre debugging, see Section 37.2, “Lustre Debugging Procedures” and Section 37.3, “Lustre Debugging for Developers”.

37.1.2.1. Tools for Administrators and Developers

Some general debugging tools provided as a part of the standard Linux distribution are:

- **strace** . This tool allows a system call to be traced.
- **/var/log/messages** . `syslogd` prints fatal or serious messages at this log.
- **Crash dumps** . On crash-dump enabled kernels, `sysrq c` produces a crash dump. The Lustre software enhances this crash dump with a log dump (the last 64 KB of the log) to the console.
- **debugfs** . Interactive file system debugger.

The following logging and data collection tools can be used to collect information for debugging Lustre kernel issues:

- **kdump** . A Linux kernel crash utility useful for debugging a system running Red Hat Enterprise Linux. For more information about `kdump`, see the Red Hat knowledge base article [How to troubleshoot kernel crashes, hangs, or reboots with kdump on Red Hat Enterprise Linux](https://access.redhat.com/solutions/6038) [https://access.redhat.com/solutions/6038]. To download `kdump`, install the RPM package via `yum install kexec-tools`.
- **netconsole** . Enables kernel-level network logging over UDP. A system requires (SysRq) allows users to collect relevant data through `netconsole`.
- **wireshark** . A network packet inspection tool that allows debugging of information that was sent between the various Lustre nodes. This tool is built on top of `tcpdump` and can read packet dumps generated by it. There are plug-ins available to disassemble the LNet and Lustre protocols. They are included with `wireshark` since version 2.6.0. See also the [Wireshark Website](https://www.wireshark.org/) [https://www.wireshark.org/] for more details.

37.1.2.2. Tools for Developers

The tools described in this section may be useful for debugging a Lustre file system in a development environment.

Of general interest is:

- **leak_finder.pl** . This program provided with the Lustre software is useful for finding memory leaks in the code.

A virtual machine is often used to create an isolated development and test environment. Some commonly-used virtual machines are:

- **VirtualBox Open Source Edition** . Provides enterprise-class virtualization capability for all major platforms and is available free at <https://www.virtualbox.org/wiki/Downloads> [https://www.virtualbox.org/wiki/Downloads].
- **VMware Server** . Virtualization platform available as free introductory software at <https://my.vmware.com/web/vmware/downloads/> [https://my.vmware.com/web/vmware/downloads/].

- **Xen**. A para-virtualized environment with virtualization capabilities similar to VMware Server and Virtual Box. However, Xen allows the use of modified kernels to provide near-native performance and the ability to emulate shared storage. For more information, go to <https://xen.org/>.

A variety of debuggers and analysis tools are available including:

- **kgdb** . The Linux Kernel Source Level Debugger kgdb is used in conjunction with the GNU Debugger gdb for debugging the Linux kernel. For more information about using kgdb with gdb, see Chapter 6. Running Programs Under gdb [https://www.linuxtopia.org/online_books/redhat_linux_debugging_with_gdb/running.html] in the *Red Hat Linux 4 Debugging with GDB* guide.
- **crash** . Used to analyze saved crash dump data when a system had panicked or locked up or appears unresponsive. For more information about using crash to analyze a crash dump, see:
 - Overview on how to use crash by the author: White Paper: Red Hat Crash Utility [https://crash-utility.github.io/crash_whitepaper.html]

37.2. Lustre Debugging Procedures

The procedures below may be useful to administrators or developers debugging a Lustre files system.

37.2.1. Understanding the Lustre Debug Messaging Format

Lustre debug messages are categorized by originating subsystem, message type, and location in the source code. For a list of subsystems and message types, see Section 44.2, “lctl”.

Note

For a current list of subsystems and debug message types, see `libcfs/include/libcfs/libcfs_debug.h` in the Lustre software tree

The elements of a Lustre debug message are described in Section 37.2.1.2, “Format of Lustre Debug Messages” Format of Lustre Debug Messages.

37.2.1.1. Lustre Debug Messages

Each Lustre debug message has the tag of the subsystem it originated in, the message type, and the location in the source code. The subsystems and debug types used are as follows:

- Standard Subsystems:

mdc, mds, osc, ost, obdclass, obdfilter, llite, ptrlpc, portals, lnd, ldlm, lov

- Debug Types:

Types	Description
trace	Function entry/exit markers
dlmtrace	Distributed locking-related information
inode	
super	

Types	Description
malloc	Memory allocation or free information
cache	Cache-related information
info	Non-critical general information
dentry	kernel namespace cache handling
mmap	Memory-mapped IO interface
page	Page cache and bulk data transfers
info	Miscellaneous informational messages
net	LNet network related debugging
console	Significant system events, printed to console
warning	Significant but non-fatal exceptions, printed to console
error	Critical error messages, printed to console
neterror	Significant LNet error messages
emerg	Fatal system errors, printed to console
config	Configuration and setup, enabled by default
ha	Failover and recovery-related information, enabled by default
hsm	Hierarchical space management/tiering
ioctl	IOCTL-related information, enabled by default
layout	File layout handling (PFL, FLR, DoM)
fsck	Filesystem consistency checking, enabled by default
other	Miscellaneous other debug messages
quota	Space accounting and management
reada	Client readahead management
rpctrace	Remote request/reply tracing and debugging
sec	Security, Kerberos, Shared Secret Key handling
snapshot	Filesystem snapshot management
vfstrace	Kernel VFS interface operations

37.2.1.2. Format of Lustre Debug Messages

The Lustre software uses the `CDEBUG()` and `CERROR()` macros to print the debug or error messages. To print the message, the `CDEBUG()` macro uses the function `libcfs_debug_msg()` (`libcfs/libcfs/tracefile.c`). The message format is described below, along with an example.

Description	Parameter
subsystem	800000
debug mask	000010
smp_processor_id	0
seconds.microseconds	1081880847.677302

Description	Parameter
stack size	1204
pid	2973
host pid (UML only) or zero	31070
(file:line #:function_name())	(obd_mount.c:2089:lustre_fill_super())
debug message	kmalloced '*obj': 24 at a375571c (tot 17447717)

37.2.1.3. Lustre Debug Messages Buffer

Lustre debug messages are maintained in a buffer, with the maximum buffer size specified (in MBs) by the `debug_mb` parameter (`lctl get_param debug_mb`). The buffer is circular, so debug messages are kept until the allocated buffer limit is reached, and then the first messages are overwritten.

37.2.2. Using the `lctl` Tool to View Debug Messages

The `lctl` tool allows debug messages to be filtered based on subsystems and message types to extract information useful for troubleshooting from a kernel debug log. For a command reference, see Section 44.2, “`lctl`”.

You can use `lctl` to:

- Obtain a list of all the types and subsystems:

```
lctl > debug_list subsystems/types
```

- Filter the debug log:

```
lctl > filter subsystem_name/debug_type
```

Note

When `lctl` filters, it removes unwanted lines from the displayed output. This does not affect the contents of the debug log in the kernel's memory. As a result, you can print the log many times with different filtering levels without worrying about losing data.

- Show debug messages belonging to certain subsystem or type:

```
lctl > show subsystem_name/debug_type
```

`debug_kernel` pulls the data from the kernel logs, filters it appropriately, and displays or saves it as per the specified options

```
lctl > debug_kernel [output filename]
```

If the debugging is being done on User Mode Linux (UML), it might be useful to save the logs on the host machine so that they can be used at a later time.

- Filter a log on disk, if you already have a debug log saved to disk (likely from a crash):

```
lctl > debug_file input_file [output_file]
```

During the debug session, you can add markers or breaks to the log for any reason:

```
lctl > mark [marker text]
```

The marker text defaults to the current date and time in the debug log (similar to the example shown below):

```
DEBUG MARKER: Tue Mar 5 16:06:44 EST 2002
```

- Completely flush the kernel debug buffer:

```
lctl > clear
```

Note

Debug messages displayed with `lctl` are also subject to the kernel debug masks; the filters are additive.

37.2.2.1. Sample `lctl` Run

Below is a sample run using the `lctl` command.

```
bash-2.04# ./lctl
lctl > debug_kernel /tmp/lustre_logs/log_all
Debug log: 324 lines, 324 kept, 0 dropped.
lctl > filter trace
Disabling output of type "trace"
lctl > debug_kernel /tmp/lustre_logs/log_notrace
Debug log: 324 lines, 282 kept, 42 dropped.
lctl > show trace
Enabling output of type "trace"
lctl > filter portals
Disabling output from subsystem "portals"
lctl > debug_kernel /tmp/lustre_logs/log_noportals
Debug log: 324 lines, 258 kept, 66 dropped.
```

37.2.3. Dumping the Buffer to a File (`debug_daemon`)

The `lctl debug_daemon` command is used to continuously dump the `debug_kernel` buffer to a user-specified file. This functionality uses a kernel thread to continuously dump the messages from the kernel debug log, so that much larger debug logs can be saved over a longer time than would fit in the kernel ringbuffer.

The `debug_daemon` is highly dependent on file system write speed. File system write operations may not be fast enough to flush out all of the `debug_buffer` if the Lustre file system is under heavy system load and continues to log debug messages to the `debug_buffer`. The `debug_daemon` will write the message `DEBUG MARKER: Trace buffer full` into the `debug_buffer` to indicate the `debug_buffer` contents are overlapping before the `debug_daemon` flushes data to a file.

Users can use the `lctl debug_daemon` command to start or stop the Lustre daemon from dumping the `debug_buffer` to a file.

37.2.3.1. `lctl debug_daemon` Commands

To initiate the `debug_daemon` to start dumping the `debug_buffer` into a file, run as the root user:

```
lctl debug_daemon start filename [megabytes]
```

The debug log will be written to the specified filename from the kernel. The file will be limited to the optionally specified number of megabytes.

The daemon wraps around and dumps data to the beginning of the file when the output file size is over the limit of the user-specified file size. To decode the dumped file to ASCII and sort the log entries by time, run:

```
lctl debug_file filename > newfile
```

The output is internally sorted by the `lctl` command.

To stop the `debug_daemon` operation and flush the file output, run:

```
lctl debug_daemon stop
```

Otherwise, `debug_daemon` is shut down as part of the Lustre file system shutdown process. Users can restart `debug_daemon` by using `start` command after each `stop` command issued.

This is an example using `debug_daemon` with the interactive mode of `lctl` to dump debug logs to a 40 MB file.

```
lctl
```

```
lctl > debug_daemon start /var/log/lustre.40.bin 40
```

```
run filesystem operations to debug
```

```
lctl > debug_daemon stop
```

```
lctl > debug_file /var/log/lustre.bin /var/log/lustre.log
```

To start another daemon with an unlimited file size, run:

```
lctl > debug_daemon start /var/log/lustre.bin
```

The text message `*** End of debug_daemon trace log ***` appears at the end of each output file.

37.2.4. Controlling Information Written to the Kernel Debug Log

The `lctl set_param subsystem_debug=subsystem_mask` and `lctl set_param debug=debug_mask` are used to determine which information is written to the debug log. The `subsystem_debug` mask determines the information written to the log based on the functional area of the code (such as `lnet`, `osc`, or `ldlm`). The `debug` mask controls information based on the message type (such as `info`, `error`, `trace`, or `malloc`). For a complete list of possible debug masks use the `lctl debug_list types` command.

To turn off Lustre debugging completely:

```
lctl set_param debug=0
```

To turn on full Lustre debugging:

```
lctl set_param debug=-1
```

To list all possible debug masks:

```
lctl debug_list types
```

To log only messages related to network communications:

```
lctl set_param debug=net
```

To turn on logging of messages related to network communications and existing debug flags:

```
lctl set_param debug=+net
```

To turn off network logging with changing existing flags:

```
lctl set_param debug=-net
```

The various options available to print to kernel debug logs are listed in `libcfs/include/libcfs/libcfs.h`

37.2.5. Troubleshooting with `strace`

The `strace` utility provided with the Linux distribution enables system calls to be traced by intercepting all the system calls made by a process and recording the system call name, arguments, and return values.

To invoke `strace` on a program, enter:

```
$ strace program [arguments]
```

Sometimes, a system call may fork child processes. In this situation, use the `-f` option of `strace` to trace the child processes:

```
$ strace -f program [arguments]
```

To redirect the `strace` output to a file, enter:

```
$ strace -o filename program [arguments]
```

Use the `-ff` option, along with `-o`, to save the trace output in `filename.pid`, where `pid` is the process ID of the process being traced. Use the `-ttt` option to timestamp all lines in the `strace` output, so they can be correlated to operations in the lustre kernel debug log.

37.2.6. Looking at Disk Content

In a Lustre file system, the inodes on the metadata server contain extended attributes (EAs) that store information about file striping. EAs contain a list of all object IDs and their locations (that is, the OST that stores them). The `lfs` tool can be used to obtain this information for a given file using the `getstripe` subcommand. Use a corresponding `lfs setstripe` command to specify striping attributes for a new file or directory.

The `lfs getstripe` command takes a Lustre filename as input and lists all the objects that form a part of this file. To obtain this information for the file `/mnt/testfs/frog` in a Lustre file system, run:

```
$ lfs getstripe /mnt/testfs/frog
lmm_stripe_count: 2
lmm_stripe_size: 1048576
lmm_pattern: 1
lmm_layout_gen: 0
lmm_stripe_offset: 2
      obdidx          objid          objid          group
```

```

2          818855          0xc7ea7          0
0          873123          0xd52a3          0

```

The `debugfs` tool is provided in the `e2fsprogs` package. It can be used for interactive debugging of an `ldiskfs` file system. The `debugfs` tool can either be used to check status or modify information in the file system. In a Lustre file system, all objects that belong to a file are stored in an underlying `ldiskfs` file system on the OSTs. The file system uses the object IDs as the file names. Once the object IDs are known, use the `debugfs` tool to obtain the attributes of all objects from different OSTs.

A sample run for the `/mnt/testfs/frog` file used in the above example is shown here:

```

$ debugfs -c -R "stat O/0/d$(818855 % 32)/818855" /dev/vgmyth/lvmythost2

debugfs 1.41.90.wc3 (28-May-2011)
/dev/vgmyth/lvmythost2: catastrophic mode - not reading inode or group bitmaps
Inode: 227649  Type: regular  Mode: 0666  Flags: 0x80000
Generation: 1375019198  Version: 0x0000002f:0000728f
User: 1000  Group: 1000  Size: 2800
File ACL: 0  Directory ACL: 0
Links: 1  Blockcount: 8
Fragment:  Address: 0  Number: 0  Size: 0
  ctime: 0x4e177fe5:00000000 -- Fri Jul  8 16:08:37 2011
  atime: 0x4d2e2397:00000000 -- Wed Jan 12 14:56:39 2011
  mtime: 0x4e177fe5:00000000 -- Fri Jul  8 16:08:37 2011
  crtime: 0x4c3b5820:a364117c -- Mon Jul 12 12:00:00 2010
Size of extra inode fields: 28
Extended attributes stored in inode body:
  fid = "08 80 24 00 00 00 00 00 28 8a e7 fc 00 00 00 00 a7 7e 0c 00 00 00 00 00
  00 00 00 00 00 00 00 00 " (32)
  fid: objid=818855 seq=0 parent=[0x248008:0xfce78a28:0x0] stripe=0
EXTENTS:
(0):63331288

```

37.2.7. Finding the Lustre UUID of an OST

To determine the Lustre UUID of an OST disk (for example, if you mix up the cables on your OST devices or the SCSI bus numbering suddenly changes and the SCSI devices get new names), it is possible to extract this from the `last_rcvd` file using `debugfs`:

```

debugfs -c -R "dump last_rcvd /tmp/last_rcvd" /dev/sdc
strings /tmp/last_rcvd | head -1
myth-OST0004_UUID

```

It is also possible (and easier) to extract this from the file system label using the `dumpe2fs` command:

```

dumpe2fs -h /dev/sdc | grep volume
dumpe2fs 1.41.90.wc3 (28-May-2011)
Filesystem volume name:  myth-OST0004

```

The `debugfs` and `dumpe2fs` commands are well documented in the `debugfs(8)` and `dumpe2fs(8)` manual pages.

37.2.8. Printing Debug Messages to the Console

To dump debug messages to the console (`/var/log/messages`), set the corresponding debug mask in the `printk` flag:

```
lctl set_param printk=-1
```

This slows down the system dramatically. It is also possible to selectively enable or disable this capability for particular flags using: `lctl set_param printk+=vfstrace` and `lctl set_param printk=-vfstrace`.

It is possible to disable warning, error, and console messages, though it is strongly recommended to have something like `lctl debug_daemon` running to capture this data to a local file system for failure detection purposes.

37.2.9. Tracing Lock Traffic

The Lustre software provides a specific debug type category for tracing lock traffic. Use:

```
lctl> filter all_types
lctl> show dlmtrace
lctl> debug_kernel [filename]
```

37.2.10. Controlling Console Message Rate Limiting

Some console messages which are printed by Lustre are rate limited. When such messages are printed, they may be followed by a message saying "Skipped N previous similar message(s)," where N is the number of messages skipped. This rate limiting can be completely disabled by a `libcfs` module parameter called `libcfs_console_ratelimit`. To disable console message rate limiting, add this line to `/etc/modprobe.d/lustre.conf` and then reload Lustre modules.

```
options libcfs libcfs_console_ratelimit=0
```

It is also possible to set the minimum and maximum delays between rate-limited console messages using the module parameters `libcfs_console_max_delay` and `libcfs_console_min_delay`. Set these in `/etc/modprobe.d/lustre.conf` and then reload Lustre modules. Additional information on `libcfs` module parameters is available via `modinfo`:

```
modinfo libcfs
```

37.3. Lustre Debugging for Developers

The procedures in this section may be useful to developers debugging Lustre source code.

37.3.1. Adding Debugging to the Lustre Source Code

The debugging infrastructure provides a number of macros that can be used in Lustre source code to aid in debugging or reporting serious errors.

To use these macros, you will need to set the `DEBUG_SUBSYSTEM` variable at the top of the file as shown below:

```
#define DEBUG_SUBSYSTEM S_PORTALS
```

A list of available macros with descriptions is provided in the table below.

Macro	Description
LBUG ()	A panic-style assertion in the kernel which causes the Lustre file system to dump its circular log to the <code>/tmp/lustre-log</code> file. This file can be retrieved after a reboot. <code>LBUG ()</code> freezes the thread to allow capture of the panic stack. A system reboot is needed to clear the thread.
LASSERT ()	Validates a given expression as true, otherwise calls <code>LBUG()</code> . The failed expression is printed on the console, although the values that make up the expression are not printed.
LASSERTF ()	Similar to <code>LASSERT ()</code> but allows a free-format message to be printed, like <code>printf/printk</code> .
CDEBUG ()	The basic, most commonly used debug macro that takes just one more argument than standard <code>printf()</code> - the debug type. This message adds to the debug log with the debug mask set accordingly. Later, when a user retrieves the log for troubleshooting, they can filter based on this type. <code>CDEBUG(D_INFO, "debug message: rc=%d\n", number);</code>
CDEBUG_LIMIT ()	Behaves similarly to <code>CDEBUG ()</code> , but rate limits this message when printing to the console (for <code>D_WARN</code> , <code>D_ERROR</code> , and <code>D_CONSOLE</code> message types. This is useful for messages that use a variable debug mask: <code>CDEBUG(mask, "maybe bad: rc=%d\n", rc);</code>
CERROR ()	Internally using <code>CDEBUG_LIMIT(D_ERROR, ...)</code> , which unconditionally prints the message in the debug log and to the console. This is appropriate for serious errors or fatal conditions. Messages printed to the console are prefixed with <code>LustreError:</code> , and are rate-limited, to avoid flooding the console with duplicates. <code>CERROR("Something bad happened: rc=%d\n", rc);</code>
CWARN ()	Behaves similarly to <code>CERROR ()</code> , but prefixes the messages with <code>Lustre:</code> . This is appropriate for important, but not fatal conditions. Messages printed to the console are rate-limited.
CNETERR ()	Behaves similarly to <code>CERROR ()</code> , but prints error messages for LNet if <code>D_NETERR</code> is set in the debug mask. This is appropriate for serious networking errors. Messages printed to the console are rate-limited.

Macro	Description
DEBUG_REQ()	Prints information about the given <code>ptlrpc_request</code> structure. <pre>DEBUG_REQ(D_RPCTRACE, req, "Handled RPC: rc=%d\n", rc);</pre>
ENTRY	Add messages to the entry of a function to aid in call tracing (takes no arguments). When using these macros, cover all exit conditions with a single <code>EXIT</code> , <code>GOTO()</code> , or <code>RETURN()</code> macro to avoid confusion when the debug log reports that a function was entered, but never exited.
EXIT	Mark the exit of a function, to match <code>ENTRY</code> (takes no arguments).
GOTO()	Mark when code jumps via <code>goto</code> to the end of a function, to match <code>ENTRY</code> , and prints out the <code>goto</code> label and function return code in signed and unsigned decimal, and hexadecimal format.
RETURN()	Mark the exit of a function, to match <code>ENTRY</code> , and prints out the function return code in signed and unsigned decimal, and hexadecimal format.
LDLM_DEBUG() LDLM_DEBUG_NOLOCK()	Used when tracing <code>LDLM</code> locking operations. These macros build a thin trace that shows the locking requests on a node, and can also be linked across the client and server node using the printed lock handles.
OBD_FAIL_CHECK()	Allows insertion of failure points into the Lustre source code. This is useful to generate regression tests that can hit a very specific sequence of events. This works in conjunction with <code>lctl set_param fail_loc=fail_loc</code> to set a specific failure point for which a given <code>OBD_FAIL_CHECK()</code> will test.
OBD_FAIL_TIMEOUT()	Similar to <code>OBD_FAIL_CHECK()</code> . Useful to simulate hung, blocked or busy processes or network devices. If the given <code>fail_loc</code> is hit, <code>OBD_FAIL_TIMEOUT()</code> waits for the specified number of seconds.
OBD_RACE()	Similar to <code>OBD_FAIL_CHECK()</code> . Useful to have multiple processes execute the same code concurrently to provoke locking races. The first process to hit <code>OBD_RACE()</code> sleeps until a second process hits <code>OBD_RACE()</code> , then both processes continue.
OBD_FAIL_ONCE	A flag set on a <code>fail_loc</code> breakpoint to cause the <code>OBD_FAIL_CHECK()</code> condition to be hit only one time. Otherwise, a <code>fail_loc</code> is permanent until it is cleared with <code>lctl set_param fail_loc=0</code> .

Macro	Description
OBD_FAIL RAND	A flag set on a <code>fail_loc</code> breakpoint to cause <code>OBD_FAIL_CHECK()</code> to fail randomly; on average every $(1 / fail_val)$ times.
OBD_FAIL SKIP	A flag set on a <code>fail_loc</code> breakpoint to cause <code>OBD_FAIL_CHECK()</code> to succeed <code>fail_val</code> times, and then fail permanently or once with <code>OBD_FAIL_ONCE</code> .
OBD_FAIL SOME	A flag set on <code>fail_loc</code> breakpoint to cause <code>OBD_FAIL_CHECK</code> to fail <code>fail_val</code> times, and then succeed.

37.3.2. Accessing the `ptlrpc` Request History

Each service maintains a request history, which can be useful for first occurrence troubleshooting.

`ptlrpc` is an RPC protocol layered on LNet that deals with stateful servers and has semantics and built-in support for recovery.

The `ptlrpc` request history works as follows:

1. `request_in_callback()` adds the new request to the service's request history.
2. When a request buffer becomes idle, it is added to the service's request buffer history list.
3. Buffers are culled from the service request buffer history if it has grown above `req_buffer_history_max` and its reqs are removed from the service request history.

Request history is accessed and controlled using the following parameters for each service:

- `req_buffer_history_len`
Number of request buffers currently in the history
- `req_buffer_history_max`
Maximum number of request buffers to keep
- `req_history`
The request history

Requests in the history include "live" requests that are currently being handled. Each line in `req_history` looks like:

sequence:target_NID:client_NID:client_xid:request_length:rpc_phase service_specific

Parameter	Description
seq	Request sequence number
<i>target NID</i>	Destination NID of the incoming request
<i>client ID</i>	Client PID and NID
<i>xid</i>	<code>rq_xid</code>
length	Size of the request message

Parameter	Description
<code>phase</code>	<ul style="list-style-type: none"> • New (waiting to be handled or could not be unpacked) • Interpret (unpacked or being handled) • Complete (handled)
<code>svc specific</code>	Service-specific request printout. Currently, the only service that does this is the OST (which prints the opcode if the message has been unpacked successfully)

37.3.3. Finding Memory Leaks Using `leak_finder.pl`

Memory leaks can occur in code when memory has been allocated and then not freed once it is no longer required. The `leak_finder.pl` program provides a way to find memory leaks.

Before running this program, you must turn on debugging to collect all `malloc` and free entries. Run:

```
lctl set_param debug+=malloc
```

Then complete the following steps:

1. Dump the log into a user-specified log file using `lctl` (see Section 37.2.2, “Using the `lctl` Tool to View Debug Messages”).
2. Run the leak finder on the newly-created log dump:

```
perl leak_finder.pl ascii-logname
```

The output is:

```
malloced 8bytes at a3116744 (called pathcopy)
(lprocfs_status.c:lprocfs_add_vars:80)
freed 8bytes at a3116744 (called pathcopy)
(lprocfs_status.c:lprocfs_add_vars:80)
```

The tool displays the following output to show the leaks found:

```
Leak:32bytes allocated at a23a8fc(service.c:ptlrpc_init_svc:144,debug file line 24
```

Part VI. Reference

Part VI includes reference information about Lustre file system user utilities, configuration files and module parameters, programming interfaces, system configuration utilities, and system limits. You will find information in this section about:

- Lustre File System Recovery
 - Lustre Parameters
 - User Utilities
 - Programming Interfaces
 - Setting Lustre Properties in a C Program (`llapi`)
 - Configuration Files and Module Parameters
 - System Configuration Utilities
-

Table of Contents

38. Lustre File System Recovery	455
38.1. Recovery Overview	455
38.1.1. Client Failure	455
38.1.2. Client Eviction	456
38.1.3. MDS Failure (Failover)	456
38.1.4. OST Failure (Failover)	457
38.1.5. Network Partition	457
38.1.6. Failed Recovery	458
38.2. Metadata Replay	458
38.2.1. XID Numbers	458
38.2.2. Transaction Numbers	458
38.2.3. Replay and Resend	459
38.2.4. Client Replay List	459
38.2.5. Server Recovery	459
38.2.6. Request Replay	460
38.2.7. Gaps in the Replay Sequence	460
38.2.8. Lock Recovery	460
38.2.9. Request Resend	461
38.3. Reply Reconstruction	461
38.3.1. Required State	461
38.3.2. Reconstruction of Open Replies	461
38.3.3. Multiple Reply Data per Client	L 2.8 462
38.4. Version-based Recovery	462
38.4.1. VBR Messages	463
38.4.2. Tips for Using VBR	463
38.5. Commit on Share	463
38.5.1. Working with Commit on Share	463
38.5.2. Tuning Commit On Share	464
38.6. Imperative Recovery	464
38.6.1. MGS role	464
38.6.2. Tuning Imperative Recovery	465
38.6.3. Configuration Suggestions for Imperative Recovery	467
38.7. Suppressing Pings	468
38.7.1. "suppress_pings" Kernel Module Parameter	468
38.7.2. Client Death Notification	468
39. Lustre Parameters	469
39.1. Introduction to Lustre Parameters	469
39.1.1. Identifying Lustre File Systems and Servers	470
39.2. Tuning Multi-Block Allocation (mballoc)	472
39.3. Monitoring Lustre File System I/O	473
39.3.1. Monitoring the Client RPC Stream	474
39.3.2. Monitoring Client Activity	475
39.3.3. Monitoring Client Read-Write Offset Statistics	477
39.3.4. Monitoring Client Read-Write Extent Statistics	478
39.3.5. Monitoring the OST Block I/O Stream	480
39.4. Tuning Lustre File System I/O	482
39.4.1. Tuning the Client I/O RPC Stream	482
39.4.2. Tuning File Readahead and Directory Statahead	484
39.4.3. Tuning Server Read Cache	485
39.4.4. Enabling OSS Asynchronous Journal Commit	488
39.4.5. Tuning the Client Metadata RPC Stream	L 2.8 489

39.5. Configuring Timeouts in a Lustre File System	490
39.5.1. Configuring Adaptive Timeouts	491
39.5.2. Setting Static Timeouts	493
39.6. Monitoring LNet	495
39.7. Allocating Free Space on OSTs	496
39.8. Configuring Locking	497
39.9. Setting MDS and OSS Thread Counts	498
39.10. Enabling and Interpreting Debugging Logs	499
39.10.1. Interpreting OST Statistics	501
39.10.2. Interpreting MDT Statistics	503
40. User Utilities	504
40.1. <code>lfs</code>	504
40.1.1. Synopsis	504
40.1.2. Description	505
40.1.3. Options	505
40.1.4. Examples	510
40.1.5. See Also	512
40.2. <code>lfs_migrate</code>	512
40.2.1. Synopsis	512
40.2.2. Description	512
40.2.3. Options	513
40.2.4. Examples	514
40.2.5. See Also	514
40.3. <code>filefrag</code>	514
40.3.1. Synopsis	514
40.3.2. Description	514
40.3.3. Options	515
40.3.4. Examples	515
40.4. <code>mount</code>	516
40.5. Handling Timeouts	516
41. Programming Interfaces	518
41.1. User/Group Upcall	518
41.1.1. Synopsis	518
41.1.2. Description	518
41.1.3. Data Structures	519
42. Setting Lustre Properties in a C Program (<code>llapi</code>)	520
42.1. <code>llapi_file_create</code>	520
42.1.1. Synopsis	520
42.1.2. Description	520
42.1.3. Examples	521
42.2. <code>llapi_file_get_stripe</code>	521
42.2.1. Synopsis	521
42.2.2. Description	522
42.2.3. Return Values	523
42.2.4. Errors	523
42.2.5. Examples	523
42.3. <code>llapi_file_open</code>	524
42.3.1. Synopsis	524
42.3.2. Description	524
42.3.3. Return Values	525
42.3.4. Errors	525
42.3.5. Example	525
42.4. <code>llapi_quotactl</code>	526
42.4.1. Synopsis	526

42.4.2. Description	526
42.4.3. Return Values	527
42.4.4. Errors	527
42.5. llapi_path2fid	528
42.5.1. Synopsis	528
42.5.2. Description	528
42.5.3. Return Values	528
42.6. llapi_ladvice	L 2.9 528
42.6.1. Synopsis	528
42.6.2. Description	529
42.6.3. Return Values	530
42.6.4. Errors	530
42.7. Example Using the llapi Library	530
42.7.1. See Also	534
43. Configuration Files and Module Parameters	535
43.1. Introduction	535
43.2. Module Options	535
43.2.1. LNet Options	536
43.2.2. SOCKLND Kernel TCP/IP LND	539
44. System Configuration Utilities	542
44.1. l_getidentity	542
44.1.1. Synopsis	542
44.1.2. Description	542
44.1.3. Options	543
44.1.4. Files	543
44.2. lctl	543
44.2.1. Synopsis	543
44.2.2. Description	543
44.2.3. Setting Parameters with lctl	543
44.2.4. Options	548
44.2.5. Examples	548
44.2.6. See Also	548
44.3. ll_decode_filter_fid	548
44.3.1. Synopsis	548
44.3.2. Description	548
44.3.3. Examples	549
44.4. llobdstat	549
44.4.1. Synopsis	549
44.4.2. Description	549
44.4.3. Example	549
44.4.4. Files	550
44.5. llog_reader	550
44.5.1. Synopsis	550
44.5.2. Description	550
44.5.3. See Also	550
44.6. llstat	550
44.6.1. Synopsis	550
44.6.2. Description	550
44.6.3. Options	551
44.6.4. Example	551
44.6.5. Files	551
44.7. llverdev	551
44.7.1. Synopsis	551
44.7.2. Description	551

44.7.3. Options	552
44.7.4. Examples	552
44.8. lshowmount	553
44.8.1. Synopsis	553
44.8.2. Description	553
44.8.3. Options	553
44.8.4. Files	553
44.9. lst	553
44.9.1. Synopsis	553
44.9.2. Description	554
44.9.3. Modules	554
44.9.4. Utilities	554
44.9.5. Example Script	554
44.10. lustre_rmmod.sh	555
44.11. lustre_rsync	555
44.11.1. Synopsis	555
44.11.2. Description	555
44.11.3. Options	556
44.11.4. Examples	557
44.11.5. See Also	557
44.12. mkfs.lustre	558
44.12.1. Synopsis	558
44.12.2. Description	558
44.12.3. Examples	560
44.12.4. See Also	560
44.13. mount.lustre	560
44.13.1. Synopsis	560
44.13.2. Description	560
44.13.3. Options	561
44.13.4. Examples	564
44.13.5. See Also	565
44.14. routerstat	565
44.14.1. Synopsis	565
44.14.2. Description	565
44.14.3. Output	565
44.14.4. Example	566
44.14.5. Files	566
44.15. tunefs.lustre	566
44.15.1. Synopsis	566
44.15.2. Description	566
44.15.3. Options	567
44.15.4. Examples	569
44.15.5. See Also	569
44.16. Additional System Configuration Utilities	569
44.16.1. More Statistics for Application Profiling	569
44.16.2. Testing / Debugging Utilities	569
44.16.3. Fileset Feature	L 2.9 570
45. LNet Configuration C-API	573
45.1. General API Information	573
45.1.1. API Return Code	573
45.1.2. API Common Input Parameters	573
45.1.3. API Common Output Parameters	573
45.2. The LNet Configuration C-API	575
45.2.1. Configuring LNet	575

45.2.2. Enabling and Disabling Routing	575
45.2.3. Adding Routes	576
45.2.4. Deleting Routes	577
45.2.5. Showing Routes	577
45.2.6. Adding a Network Interface	578
45.2.7. Deleting a Network Interface	579
45.2.8. Showing Network Interfaces	580
45.2.9. Adjusting Router Buffer Pools	581
45.2.10. Showing Routing information	582
45.2.11. Showing LNet Traffic Statistics	583
45.2.12. Adding/Deleting/Showing Parameters through a YAML Block	584
45.2.13. Adding a route code example	585

Chapter 38. Lustre File System Recovery

This chapter describes how recovery is implemented in a Lustre file system and includes the following sections:

- Section 38.1, “Recovery Overview”
- Section 38.2, “Metadata Replay”
- Section 38.3, “Reply Reconstruction”
- Section 38.4, “Version-based Recovery”
- Section 38.5, “Commit on Share”
- Section 38.6, “Imperative Recovery”

38.1. Recovery Overview

The recovery feature provided in the Lustre software is responsible for dealing with node or network failure and returning the cluster to a consistent, performant state. Because the Lustre software allows servers to perform asynchronous update operations to the on-disk file system (i.e., the server can reply without waiting for the update to synchronously commit to disk), the clients may have state in memory that is newer than what the server can recover from disk after a crash.

A handful of different types of failures can cause recovery to occur:

- Client (compute node) failure
- MDS failure (and failover)
- OST failure (and failover)
- Transient network partition

For Lustre, all Lustre file system failure and recovery operations are based on the concept of connection failure; all imports or exports associated with a given connection are considered to fail if any of them fail. The Section 38.6, “Imperative Recovery” feature allows the MGS to actively inform clients when a target restarts after a failure, failover, or other interruption to speed up recovery.

For information on Lustre file system recovery, see Section 38.2, “Metadata Replay”. For information on recovering from a corrupt file system, see Section 38.5, “Commit on Share”. For information on resolving orphaned objects, a common issue after recovery, see Section 36.2.1, “Working with Orphaned Objects”. For information on imperative recovery see Section 38.6, “Imperative Recovery”

38.1.1. Client Failure

Recovery from client failure in a Lustre file system is based on lock revocation and other resources, so surviving clients can continue their work uninterrupted. If a client fails to timely respond to a blocking lock callback from the Distributed Lock Manager (DLM) or fails to communicate with the server in a long

period of time (i.e., no pings), the client is forcibly removed from the cluster (evicted). This enables other clients to acquire locks blocked by the dead client's locks, and also frees resources (file handles, export data) associated with that client. Note that this scenario can be caused by a network partition, as well as an actual client node system failure. Section 38.1.5, “Network Partition” describes this case in more detail.

38.1.2. Client Eviction

If a client is not behaving properly from the server's point of view, it will be evicted. This ensures that the whole file system can continue to function in the presence of failed or misbehaving clients. An evicted client must invalidate all locks, which in turn, results in all cached inodes becoming invalidated and all cached data being flushed.

Reasons why a client might be evicted:

- Failure to respond to a server request in a timely manner
 - Blocking lock callback (i.e., client holds lock that another client/server wants)
 - Lock completion callback (i.e., client is granted lock previously held by another client)
 - Lock glimpse callback (i.e., client is asked for size of object by another client)
 - Server shutdown notification (with simplified interoperability)
- Failure to ping the server in a timely manner, unless the server is receiving no RPC traffic at all (which may indicate a network partition).

38.1.3. MDS Failure (Failover)

Highly-available (HA) Lustre file system operation requires that the metadata server have a peer configured for failover, including the use of a shared storage device for the MDT backing file system. The actual mechanism for detecting peer failure, power off (STONITH) of the failed peer (to prevent it from continuing to modify the shared disk), and takeover of the Lustre MDS service on the backup node depends on external HA software such as Heartbeat. It is also possible to have MDS recovery with a single MDS node. In this case, recovery will take as long as is needed for the single MDS to be restarted.

When Section 38.6, “Imperative Recovery” is enabled, clients are notified of an MDS restart (either the backup or a restored primary). Clients always may detect an MDS failure either by timeouts of in-flight requests or idle-time ping messages. In either case the clients then connect to the new backup MDS and use the Metadata Replay protocol. Metadata Replay is responsible for ensuring that the backup MDS re-acquires state resulting from transactions whose effects were made visible to clients, but which were not committed to the disk.

The reconnection to a new (or restarted) MDS is managed by the file system configuration loaded by the client when the file system is first mounted. If a failover MDS has been configured (using the `--failnode=` option to `mkfs.lustre` or `tunefs.lustre`), the client tries to reconnect to both the primary and backup MDS until one of them responds that the failed MDT is again available. At that point, the client begins recovery. For more information, see Section 38.2, “Metadata Replay”.

Transaction numbers are used to ensure that operations are replayed in the order they were originally performed, so that they are guaranteed to succeed and present the same file system state as before the failure. In addition, clients inform the new server of their existing lock state (including locks that have not yet been granted). All metadata and lock replay must complete before new, non-recovery operations are permitted. In addition, only clients that were connected at the time of MDS failure are permitted to

reconnect during the recovery window, to avoid the introduction of state changes that might conflict with what is being replayed by previously-connected clients.

If multiple MDTs are in use, active-active failover is possible (e.g. two MDS nodes, each actively serving one or more different MDTs for the same filesystem). See Section 3.2.2, “MDT Failover Configuration (Active/Active)” for more information.

38.1.4. OST Failure (Failover)

When an OST fails or has communication problems with the client, the default action is that the corresponding OSC enters recovery, and I/O requests going to that OST are blocked waiting for OST recovery or failover. It is possible to administratively mark the OSC as *inactive* on the client, in which case file operations that involve the failed OST will return an IO error (-EIO). Otherwise, the application waits until the OST has recovered or the client process is interrupted (e.g. ,with *CTRL-C*).

The MDS (via the LOV) detects that an OST is unavailable and skips it when assigning objects to new files. When the OST is restarted or re-establishes communication with the MDS, the MDS and OST automatically perform orphan recovery to destroy any objects that belong to files that were deleted while the OST was unavailable. For more information, see Chapter 36, *Troubleshooting Recovery (Working with Orphaned Objects)*.

While the OSC to OST operation recovery protocol is the same as that between the MDC and MDT using the Metadata Replay protocol, typically the OST commits bulk write operations to disk synchronously and each reply indicates that the request is already committed and the data does not need to be saved for recovery. In some cases, the OST replies to the client before the operation is committed to disk (e.g. truncate, destroy, setattr, and I/O operations in newer releases of the Lustre software), and normal replay and resend handling is done, including resending of the bulk writes. In this case, the client keeps a copy of the data available in memory until the server indicates that the write has committed to disk.

To force an OST recovery, unmount the OST and then mount it again. If the OST was connected to clients before it failed, then a recovery process starts after the remount, enabling clients to reconnect to the OST and replay transactions in their queue. When the OST is in recovery mode, all new client connections are refused until the recovery finishes. The recovery is complete when either all previously-connected clients reconnect and their transactions are replayed or a client connection attempt times out. If a connection attempt times out, then all clients waiting to reconnect (and their transactions) are lost.

Note

If you know an OST will not recover a previously-connected client (if, for example, the client has crashed), you can manually abort the recovery using this command:

```
oss# lctl --device lustre_device_number abort_recovery
```

To determine an OST's device number and device name, run the `lctl dl` command. Sample `lctl dl` command output is shown below:

```
7 UP obdfilter ddn_data-OST0009 ddn_data-OST0009_UUID 1159
```

In this example, 7 is the OST device number. The device name is `ddn_data-OST0009`. In most instances, the device name can be used in place of the device number.

38.1.5. Network Partition

Network failures may be transient. To avoid invoking recovery, the client tries, initially, to re-send any timed out request to the server. If the resend also fails, the client tries to re-establish a connection to the

server. Clients can detect harmless partition upon reconnect if the server has not had any reason to evict the client.

If a request was processed by the server, but the reply was dropped (i.e., did not arrive back at the client), the server must reconstruct the reply when the client resends the request, rather than performing the same request twice.

38.1.6. Failed Recovery

In the case of failed recovery, a client is evicted by the server and must reconnect after having flushed its saved state related to that server, as described in Section 38.1.2, “Client Eviction”, above. Failed recovery might occur for a number of reasons, including:

- Failure of recovery
 - Recovery fails if the operations of one client directly depend on the operations of another client that failed to participate in recovery. Otherwise, Version Based Recovery (VBR) allows recovery to proceed for all of the connected clients, and only missing clients are evicted.
- Manual abort of recovery
- Manual eviction by the administrator

38.2. Metadata Replay

Highly available Lustre file system operation requires that the MDS have a peer configured for failover, including the use of a shared storage device for the MDS backing file system. When a client detects an MDS failure, it connects to the new MDS and uses the metadata replay protocol to replay its requests.

Metadata replay ensures that the failover MDS re-accumulates state resulting from transactions whose effects were made visible to clients, but which were not committed to the disk.

38.2.1. XID Numbers

Each request sent by the client contains an XID number, which is a client-unique, monotonically increasing 64-bit integer. The initial value of the XID is chosen so that it is highly unlikely that the same client node reconnecting to the same server after a reboot would have the same XID sequence. The XID is used by the client to order all of the requests that it sends, until such a time that the request is assigned a transaction number. The XID is also used in Reply Reconstruction to uniquely identify per-client requests at the server.

38.2.2. Transaction Numbers

Each client request processed by the server that involves any state change (metadata update, file open, write, etc., depending on server type) is assigned a transaction number by the server that is a target-unique, monotonically increasing, server-wide 64-bit integer. The transaction number for each file system-modifying request is sent back to the client along with the reply to that client request. The transaction numbers allow the client and server to unambiguously order every modification to the file system in case recovery is needed.

Each reply sent to a client (regardless of request type) also contains the last committed transaction number that indicates the highest transaction number committed to the file system. The `ldiskfs` and `ZFS` backing file systems that the Lustre software uses enforces the requirement that any earlier disk operation will always be committed to disk before a later disk operation, so the last committed transaction number also reports that any requests with a lower transaction number have been committed to disk.

38.2.3. Replay and Resend

Lustre file system recovery can be separated into two distinct types of operations: *replay* and *resend*.

Replay operations are those for which the client received a reply from the server that the operation had been successfully completed. These operations need to be redone in exactly the same manner after a server restart as had been reported before the server failed. Replay can only happen if the server failed; otherwise it will not have lost any state in memory.

Resend operations are those for which the client never received a reply, so their final state is unknown to the client. The client sends unanswered requests to the server again in XID order, and again awaits a reply for each one. In some cases, resent requests have been handled and committed to disk by the server (possibly also having dependent operations committed), in which case, the server performs reply reconstruction for the lost reply. In other cases, the server did not receive the lost request at all and processing proceeds as with any normal request. These are what happen in the case of a network interruption. It is also possible that the server received the request, but was unable to reply or commit it to disk before failure.

38.2.4. Client Replay List

All file system-modifying requests have the potential to be required for server state recovery (replay) in case of a server failure. Replies that have an assigned transaction number that is higher than the last committed transaction number received in any reply from each server are preserved for later replay in a per-server replay list. As each reply is received from the server, it is checked to see if it has a higher last committed transaction number than the previous highest last committed number. Most requests that now have a lower transaction number can safely be removed from the replay list. One exception to this rule is for open requests, which need to be saved for replay until the file is closed so that the MDS can properly reference count open-unlinked files.

38.2.5. Server Recovery

A server enters recovery if it was not shut down cleanly. If, upon startup, if any client entries are in the `last_rcvd` file for any previously connected clients, the server enters recovery mode and waits for these previously-connected clients to reconnect and begin replaying or resending their requests. This allows the server to recreate state that was exposed to clients (a request that completed successfully) but was not committed to disk before failure.

In the absence of any client connection attempts, the server waits indefinitely for the clients to reconnect. This is intended to handle the case where the server has a network problem and clients are unable to reconnect and/or if the server needs to be restarted repeatedly to resolve some problem with hardware or software. Once the server detects client connection attempts - either new clients or previously-connected clients - a recovery timer starts and forces recovery to finish in a finite time regardless of whether the previously-connected clients are available or not.

If no client entries are present in the `last_rcvd` file, or if the administrator manually aborts recovery, the server does not wait for client reconnection and proceeds to allow all clients to connect.

As clients connect, the server gathers information from each one to determine how long the recovery needs to take. Each client reports its connection UUID, and the server does a lookup for this UUID in the `last_rcvd` file to determine if this client was previously connected. If not, the client is refused connection and it will retry until recovery is completed. Each client reports its last seen transaction, so the server knows when all transactions have been replayed. The client also reports the amount of time that it was previously waiting for request completion so that the server can estimate how long some clients might need to detect the server failure and reconnect.

If the client times out during replay, it attempts to reconnect. If the client is unable to reconnect, `REPLAY` fails and it returns to `DISCON` state. It is possible that clients will timeout frequently during `REPLAY`, so reconnection should not delay an already slow process more than necessary. We can mitigate this by increasing the timeout during replay.

38.2.6. Request Replay

If a client was previously connected, it gets a response from the server telling it that the server is in recovery and what the last committed transaction number on disk is. The client can then iterate through its replay list and use this last committed transaction number to prune any previously-committed requests. It replays any newer requests to the server in transaction number order, one at a time, waiting for a reply from the server before replaying the next request.

Open requests that are on the replay list may have a transaction number lower than the server's last committed transaction number. The server processes those open requests immediately. The server then processes replayed requests from all of the clients in transaction number order, starting at the last committed transaction number to ensure that the state is updated on disk in exactly the same manner as it was before the crash. As each replayed request is processed, the last committed transaction is incremented. If the server receives a replay request from a client that is higher than the current last committed transaction, that request is put aside until other clients provide the intervening transactions. In this manner, the server replays requests in the same sequence as they were previously executed on the server until either all clients are out of requests to replay or there is a gap in a sequence.

38.2.7. Gaps in the Replay Sequence

In some cases, a gap may occur in the reply sequence. This might be caused by lost replies, where the request was processed and committed to disk but the reply was not received by the client. It can also be caused by clients missing from recovery due to partial network failure or client death.

In the case where all clients have reconnected, but there is a gap in the replay sequence the only possibility is that some requests were processed by the server but the reply was lost. Since the client must still have these requests in its resend list, they are processed after recovery is finished.

In the case where all clients have not reconnected, it is likely that the failed clients had requests that will no longer be replayed. The VBR feature is used to determine if a request following a transaction gap is safe to be replayed. Each item in the file system (MDS inode or OST object) stores on disk the number of the last transaction in which it was modified. Each reply from the server contains the previous version number of the objects that it affects. During VBR replay, the server matches the previous version numbers in the resend request against the current version number. If the versions match, the request is the next one that affects the object and can be safely replayed. For more information, see Section 38.4, “Version-based Recovery”.

38.2.8. Lock Recovery

If all requests were replayed successfully and all clients reconnected, clients then do lock replay locks -- that is, every client sends information about every lock it holds from this server and its state (whenever it was granted or not, what mode, what properties and so on), and then recovery completes successfully. Currently, the Lustre software does not do lock verification and just trusts clients to present an accurate lock state. This does not impart any security concerns since Lustre software release 1.x clients are trusted for other information (e.g. user ID) during normal operation also.

After all of the saved requests and locks have been replayed, the client sends an `MDS_GETSTATUS` request with last-replay flag set. The reply to that request is held back until all clients have completed replay (sent

the same flagged getstatus request), so that clients don't send non-recovery requests before recovery is complete.

38.2.9. Request Resend

Once all of the previously-shared state has been recovered on the server (the target file system is up-to-date with client cache and the server has recreated locks representing the locks held by the client), the client can resend any requests that did not receive an earlier reply. This processing is done like normal request processing, and, in some cases, the server may do reply reconstruction.

38.3. Reply Reconstruction

When a reply is dropped, the MDS needs to be able to reconstruct the reply when the original request is re-sent. This must be done without repeating any non-idempotent operations, while preserving the integrity of the locking system. In the event of MDS failover, the information used to reconstruct the reply must be serialized on the disk in transactions that are joined or nested with those operating on the disk.

38.3.1. Required State

For the majority of requests, it is sufficient for the server to store three pieces of data in the `last_rcvd` file:

- XID of the request
- Resulting transno (if any)
- Result code (`req->rq_status`)

For open requests, the "disposition" of the open must also be stored.

38.3.2. Reconstruction of Open Replies

An open reply consists of up to three pieces of information (in addition to the contents of the "request log"):

- File handle
- Lock handle
- `mds_body` with information about the file created (for `O_CREAT`)

The disposition, status and request data (re-sent intact by the client) are sufficient to determine which type of lock handle was granted, whether an open file handle was created, and which resource should be described in the `mds_body`.

38.3.2.1. Finding the File Handle

The file handle can be found in the XID of the request and the list of per-export open file handles. The file handle contains the resource/FID.

38.3.2.2. Finding the Resource/fid

The file handle contains the resource/fid.

38.3.2.3. Finding the Lock Handle

The lock handle can be found by walking the list of granted locks for the resource looking for one with the appropriate remote file handle (present in the re-sent request). Verify that the lock has the right mode (determined by performing the disposition/request/status analysis above) and is granted to the proper client.

Introduced in Lustre 2.8

38.3.3. Multiple Reply Data per Client

Since Lustre 2.8, the MDS is able to save several reply data per client. The reply data are stored in the `reply_data` internal file of the MDT. Additionally to the `XID` of the request, the transaction number, the result code and the open "disposition", the reply data contains a generation number that identifies the client thanks to the content of the `last_rcvd` file.

38.4. Version-based Recovery

The Version-based Recovery (VBR) feature improves Lustre file system reliability in cases where client requests (RPCs) fail to replay during recovery¹.

In pre-VBR releases of the Lustre software, if the MGS or an OST went down and then recovered, a recovery process was triggered in which clients attempted to replay their requests. Clients were only allowed to replay RPCs in serial order. If a particular client could not replay its requests, then those requests were lost as well as the requests of clients later in the sequence. The "downstream" clients never got to replay their requests because of the wait on the earlier client's RPCs. Eventually, the recovery period would time out (so the component could accept new requests), leaving some number of clients evicted and their requests and data lost.

With VBR, the recovery mechanism does not result in the loss of clients or their data, because changes in inode versions are tracked, and more clients are able to reintegrate into the cluster. With VBR, inode tracking looks like this:

- Each inode² stores a version, that is, the number of the last transaction (`transno`) in which the inode was changed.
- When an inode is about to be changed, a pre-operation version of the inode is saved in the client's data.
- The client keeps the pre-operation inode version and the post-operation version (transaction number) for replay, and sends them in the event of a server failure.
- If the pre-operation version matches, then the request is replayed. The post-operation version is assigned on all inodes modified in the request.

Note

An RPC can contain up to four pre-operation versions, because several inodes can be involved in an operation. In the case of a "rename" operation, four different inodes can be modified.

During normal operation, the server:

¹There are two scenarios under which client RPCs are not replayed: (1) Non-functioning or isolated clients do not reconnect, and they cannot replay their RPCs, causing a gap in the replay sequence. These clients get errors and are evicted. (2) Functioning clients connect, but they cannot replay some or all of their RPCs that occurred after the gap caused by the non-functioning/isolated clients. These clients get errors (caused by the failed clients). With VBR, these requests have a better chance to replay because the "gaps" are only related to specific files that the missing client(s) changed.

²Usually, there are two inodes, a parent and a child.

- Updates the versions of all inodes involved in a given operation
- Returns the old and new inode versions to the client with the reply

When the recovery mechanism is underway, VBR follows these steps:

1. VBR only allows clients to replay transactions if the affected inodes have the same version as during the original execution of the transactions, even if there is gap in transactions due to a missed client.
2. The server attempts to execute every transaction that the client offers, even if it encounters a re-integration failure.
3. When the replay is complete, the client and server check if a replay failed on any transaction because of inode version mismatch. If the versions match, the client gets a successful re-integration message. If the versions do not match, then the client is evicted.

VBR recovery is fully transparent to users. It may lead to slightly longer recovery times if the cluster loses several clients during server recovery.

38.4.1. VBR Messages

The VBR feature is built into the Lustre file system recovery functionality. It cannot be disabled. These are some VBR messages that may be displayed:

```
DEBUG_REQ(D_WARNING, req, "Version mismatch during replay\n");
```

This message indicates why the client was evicted. No action is needed.

```
CWARN("%s: version recovery fails, reconnecting\n");
```

This message indicates why the recovery failed. No action is needed.

38.4.2. Tips for Using VBR

VBR will be successful for clients which do not share data with other client. Therefore, the strategy for reliable use of VBR is to store a client's data in its own directory, where possible. VBR can recover these clients, even if other clients are lost.

38.5. Commit on Share

The commit-on-share (COS) feature makes Lustre file system recovery more reliable by preventing missing clients from causing cascading evictions of other clients. With COS enabled, if some Lustre clients miss the recovery window after a reboot or a server failure, the remaining clients are not evicted.

Note

The commit-on-share feature is enabled, by default.

38.5.1. Working with Commit on Share

To illustrate how COS works, let's first look at the old recovery scenario. After a service restart, the MDS would boot and enter recovery mode. Clients began reconnecting and replaying their uncommitted transactions. Clients could replay transactions independently as long as their transactions did not depend on each other (one client's transactions did not depend on a different client's transactions). The MDS is able to determine whether one transaction is dependent on another transaction via the Section 38.4, "Version-based Recovery" feature.

If there was a dependency between client transactions (for example, creating and deleting the same file), and one or more clients did not reconnect in time, then some clients may have been evicted because their transactions depended on transactions from the missing clients. Evictions of those clients caused more clients to be evicted and so on, resulting in "cascading" client evictions.

COS addresses the problem of cascading evictions by eliminating dependent transactions between clients. It ensures that one transaction is committed to disk if another client performs a transaction dependent on the first one. With no dependent, uncommitted transactions to apply, the clients replay their requests independently without the risk of being evicted.

38.5.2. Tuning Commit On Share

Commit on Share can be enabled or disabled using the `mdt.commit_on_sharing` tunable (0/1). This tunable can be set when the MDS is created (`mkfs.lustre`) or when the Lustre file system is active, using the `lctl set/get_param` or `lctl conf_param` commands.

To set a default value for COS (disable/enable) when the file system is created, use:

```
--param mdt.commit_on_sharing=0/1
```

To disable or enable COS when the file system is running, use:

```
lctl set_param mdt.*.commit_on_sharing=0/1
```

Note

Enabling COS may cause the MDS to do a large number of synchronous disk operations, hurting performance. Placing the `ldiskfs` journal on a low-latency external device may improve file system performance.

38.6. Imperative Recovery

Large-scale Lustre filesystems will experience server hardware failures over their lifetime, and it is important that servers can recover in a timely manner after such failures. High Availability software can move storage targets over to a backup server automatically. Clients can detect the server failure by RPC timeouts, which must be scaled with system size to prevent false diagnosis of server death in cases of heavy load. The purpose of imperative recovery is to reduce the recovery window by actively informing clients of server failure. The resulting reduction in the recovery window will minimize target downtime and therefore increase overall system availability.

Imperative Recovery does not remove previous recovery mechanisms, and client timeout-based recovery actions can occur in a cluster when IR is enabled as each client can still independently disconnect and reconnect from a target. In case of a mix of IR and non-IR clients connecting to an OST or MDT, the server cannot reduce its recovery timeout window, because it cannot be sure that all clients have been notified of the server restart in a timely manner. Even in such mixed environments the time to complete recovery may be reduced, since IR-enabled clients will still be notified to reconnect to the server promptly and allow recovery to complete as soon as the last non-IR client detects the server failure.

38.6.1. MGS role

The MGS now holds additional information about Lustre targets, in the form of a Target Status Table. Whenever a target registers with the MGS, there is a corresponding entry in this table identifying the target. This entry includes NID information, and state/version information for the target. When a client mounts the file system, it caches a locked copy of this table, in the form of a Lustre configuration log. When a target restart occurs, the MGS revokes the client lock, forcing all clients to reload the table. Any new

targets will have an updated version number, the client detects this and reconnects to the restarted target. Since successful IR notification of server restart depends on all clients being registered with the MGS, and there is no other node to notify clients in case of MGS restart, the MGS will disable IR for a period when it first starts. This interval is configurable, as shown in Section 38.6.2, “Tuning Imperative Recovery”

Because of the increased importance of the MGS in recovery, it is strongly recommended that the MGS node be separate from the MDS. If the MGS is co-located on the MDS node, then in case of MDS/MGS failure there will be no IR notification for the MDS restart, and clients will always use timeout-based recovery for the MDS. IR notification would still be used in the case of OSS failure and recovery.

Unfortunately, it’s impossible for the MGS to know how many clients have been successfully notified or whether a specific client has received the restarting target information. The only thing the MGS can do is tell the target that, for example, all clients are imperative recovery-capable, so it is not necessary to wait as long for all clients to reconnect. For this reason, we still require a timeout policy on the target side, but this timeout value can be much shorter than normal recovery.

38.6.2. Tuning Imperative Recovery

Imperative recovery has a default parameter set which means it can work without any extra configuration. However, the default parameter set only fits a generic configuration. The following sections discuss the configuration items for imperative recovery.

38.6.2.1. *ir_factor*

Ir_factor is used to control targets’ recovery window. If imperative recovery is enabled, the recovery timeout window on the restarting target is calculated by: $new\ timeout = recovery_time * ir_factor / 10$. *Ir_factor* must be a value in range of [1, 10]. The default value of *ir_factor* is 5. The following example will set imperative recovery timeout to 80% of normal recovery timeout on the target testfs-OST0000:

```
lctl conf_param obdfilter.testfs-OST0000.ir_factor=8
```

Note

If this value is too small for the system, clients may be unnecessarily evicted

You can read the current value of the parameter in the standard manner with *lctl get_param*:

```
# lctl get_param obdfilter.testfs-OST0000.ir_factor
# obdfilter.testfs-OST0000.ir_factor=8
```

38.6.2.2. Disabling Imperative Recovery

Imperative recovery can be disabled manually by a mount option. For example, imperative recovery can be disabled on an OST by:

```
# mount -t lustre -onoir /dev/sda /mnt/ost1
```

Imperative recovery can also be disabled on the client side with the same mount option:

```
# mount -t lustre -onoir mymgsnid@tcp:/testfs /mnt/testfs
```

Note

When a single client is deactivated in this manner, the MGS will deactivate imperative recovery for the whole cluster. IR-enabled clients will still get notification of target restart, but targets will not be allowed to shorten the recovery window.

You can also disable imperative recovery globally on the MGS by writing `state=disabled` to the controlling procsfs entry

```
# lctl set_param mgs.MGS.live.testfs="state=disabled"
```

The above command will disable imperative recovery for file system named *testfs*

38.6.2.3. Checking Imperative Recovery State - MGS

You can get the imperative recovery state from the MGS. Let's take an example and explain states of imperative recovery:

```
[mgs]$ lctl get_param mgs.MGS.live.testfs
...
imperative_recovery_state:
  state: full
  nonir_clients: 0
  nidthbl_version: 242
  notify_duration_total: 0.470000
  notify_duation_max: 0.041000
  notify_count: 38
```

Item	Meaning
state	<ul style="list-style-type: none"> • full: IR is working, all clients are connected and can be notified. • partial: some clients are not IR capable. • disabled: IR is disabled, no client notification. • startup: the MGS was just restarted, so not all clients may reconnect to the MGS.
nonir_clients	Number of non-IR capable clients in the system.
nidthbl_version	Version number of the target status table. Client version must match MGS.
notify_duration_total	[Seconds.microseconds] Total time spent by MGS notifying clients
notify_duration_max	[Seconds.microseconds] Maximum notification time for the MGS to notify a single IR client.
notify_count	Number of MGS restarts - to obtain average notification time, divide notify_duration_total by notify_count

38.6.2.4. Checking Imperative Recovery State - client

A `client` in IR means a Lustre client or a MDT. You can get the IR state on any node which running client or MDT, those nodes will always have an MGC running. An example from a client:

```
[client]$ lctl get_param mgc.*.ir_state
```

```

mgc.MGC192.168.127.6@tcp.ir_state=
imperative_recovery: ON
client_state:
  - { client: testfs-client, nidtbl_version: 242 }

```

An example from a MDT:

```

mgc.MGC192.168.127.6@tcp.ir_state=
imperative_recovery: ON
client_state:
  - { client: testfs-MDT0000, nidtbl_version: 242 }

```

Item	Meaning
imperative_recovery	imperative_recovery can be ON or OFF. If it's OFF state, then IR is disabled by administrator at mount time. Normally this should be ON state.
client_state: client:	The name of the client
client_state: nidtbl_version	Version number of the target status table. Client version must match MGS.

38.6.2.5. Target Instance Number

The Target Instance number is used to determine if a client is connecting to the latest instance of a target. We use the lowest 32 bit of mount count as target instance number. For an OST you can get the target instance number of testfs-OST0001 in this way (the command is run from an OSS login prompt):

```

$ lctl get_param obdfilter.testfs-OST0001*.instance
obdfilter.testfs-OST0001.instance=5

```

From a client, query the relevant OSC:

```

$ lctl get_param osc.testfs-OST0001-osc-*.import |grep instance
instance: 5

```

38.6.3. Configuration Suggestions for Imperative Recovery

We used to build the MGS and MDT0000 on the same target to save a server node. However, to make IR work efficiently, we strongly recommend running the MGS node on a separate node for any significant Lustre file system installation. There are three main advantages of doing this:

1. Be able to notify clients when MDT0000 recovered.
2. Improved load balance. The load on the MDS may be very high which may make the MGS unable to notify the clients in time.
3. Robustness. The MGS code is simpler and much smaller compared to the MDS code. This means the chance of an MGS downtime due to a software bug is very low.

38.7. Suppressing Pings

On clusters with large numbers of clients and OSTs, OBD_PING messages may impose significant performance overheads. There is an option to suppress pings, allowing ping overheads to be considerably reduced. Before turning on this option, administrators should consider the following requirements and understand the trade-offs involved:

- When suppressing pings, a server cannot detect client deaths, since clients do not send pings that are only to keep their connections alive. Therefore, a mechanism external to the Lustre file system shall be set up to notify Lustre targets of client deaths in a timely manner, so that stale connections do not exist for too long and lock callbacks to dead clients do not always have to wait for timeouts.
- Without pings, a client has to rely on Imperative Recovery to notify it of target failures, in order to join recoveries in time. This dictates that the client shall eagerly keep its MGS connection alive. Thus, a highly available standalone MGS is recommended and, on the other hand, MGS pings are always sent regardless of how the option is set.
- If a client has uncommitted requests to a target and it is not sending any new requests on the connection, it will still ping that target even when pings should be suppressed. This is because the client needs to query the target's last committed transaction numbers in order to free up local uncommitted requests (and possibly other resources associated). However, these pings shall stop as soon as all the uncommitted requests have been freed or new requests need to be sent, rendering the pings unnecessary.

38.7.1. "suppress_pings" Kernel Module Parameter

The new option that controls whether pings are suppressed is implemented as the `ptlrpc` kernel module parameter `"suppress_pings"`. Setting it to `"1"` on a server turns on ping suppressing for all targets on that server, while leaving it with the default value `"0"` gives previous pingging behavior. The parameter is ignored on clients and the MGS. While the parameter is recommended to be set persistently via the `modprobe.conf(5)` mechanism, it also accept online changes through `sysfs`. Note that an online change only affects connections established later; existing connections' pingging behaviors stay the same.

38.7.2. Client Death Notification

The required external client death notification shall write UUIDs of dead clients into targets' `evict_client` `procfs` entries in order to remove stale clients from recovery.

A client UUID can be obtained from their `uuid` `procfs` entry and that UUID can be used to evict the client, like:

```
client$ lctl get_param llite.testfs-*.uuid
llite.testfs-ffff991ae1992000.uuid=dd599d28-0a85-a9e4-82cd-dc6357a42c77
oss# lctl set_param obdfilter.testfs-*.evict_client=dd599d28-0a85-a9e4-82cd-dc6357
mds# lctl set_param mdt.testfs-*.evict_client=dd599d28-0a85-a9e4-82cd-dc6357a42c77
```

Chapter 39. Lustre Parameters

There are many parameters for Lustre that can tune client and server performance, change behavior of the system, and report statistics about various subsystems. This chapter describes the various parameters and tunables that are useful for optimizing and monitoring aspects of a Lustre file system. It includes these sections:

- Section 39.10, “Enabling and Interpreting Debugging Logs”

39.1. Introduction to Lustre Parameters

Lustre parameters and statistics files provide an interface to internal data structures in the kernel that enables monitoring and tuning of many aspects of Lustre file system and application performance. These data structures include settings and metrics for components such as memory, networking, file systems, and kernel housekeeping routines, which are available throughout the hierarchical file layout.

Typically, metrics are accessed via `lctl get_param` files and settings are changed by via `lctl set_param`. They allow getting and setting multiple parameters with a single command, through the use of wildcards in one or more part of the parameter name. While each of these parameters maps to files in `/proc` and `/sys` directly, the location of these parameters may change between Lustre releases, so it is recommended to always use `lctl` to access the parameters from userspace scripts. Some data is server-only, some data is client-only, and some data is exported from the client to the server and is thus duplicated in both locations.

Note

In the examples in this chapter, # indicates a command is entered as root. Lustre servers are named according to the convention `fsname-MDT/OSTnumber`. The standard UNIX wildcard designation (*) is used to represent any part of a single component of the parameter name, excluding "." and "/". It is also possible to use brace {} expansion to specify a list of parameter names efficiently.

Some examples are shown below:

- To list available OST targets on a Lustre client:

```
# lctl list_param -F osc.*
osc.testfs-OST0000-osc-ffff881071d5cc00/
osc.testfs-OST0001-osc-ffff881071d5cc00/
osc.testfs-OST0002-osc-ffff881071d5cc00/
osc.testfs-OST0003-osc-ffff881071d5cc00/
osc.testfs-OST0004-osc-ffff881071d5cc00/
osc.testfs-OST0005-osc-ffff881071d5cc00/
osc.testfs-OST0006-osc-ffff881071d5cc00/
osc.testfs-OST0007-osc-ffff881071d5cc00/
osc.testfs-OST0008-osc-ffff881071d5cc00/
```

In this example, information about OST connections available on a client is displayed (indicated by "osc"). Each of these connections may have numerous sub-parameters as well.

- To see multiple levels of parameters, use multiple wildcards:

```
# lctl list_param osc.*.*
osc.testfs-OST0000-osc-ffff881071d5cc00.active
osc.testfs-OST0000-osc-ffff881071d5cc00.blocksize
osc.testfs-OST0000-osc-ffff881071d5cc00.checksum_type
osc.testfs-OST0000-osc-ffff881071d5cc00.checksums
osc.testfs-OST0000-osc-ffff881071d5cc00.connect_flags
osc.testfs-OST0000-osc-ffff881071d5cc00.contention_seconds
osc.testfs-OST0000-osc-ffff881071d5cc00.cur_dirty_bytes
...
osc.testfs-OST0000-osc-ffff881071d5cc00.rpc_stats
```

- To see a specific subset of parameters, use braces, like:

```
# lctl list_param osc.*.{checksum,connect}*
osc.testfs-OST0000-osc-ffff881071d5cc00.checksum_type
osc.testfs-OST0000-osc-ffff881071d5cc00.checksums
osc.testfs-OST0000-osc-ffff881071d5cc00.connect_flags
```

- To view a specific file, use `lctl get_param`:

```
# lctl get_param osc.lustre-OST0000*.rpc_stats
```

For more information about using `lctl`, see Section 13.12.3, “Setting Parameters with `lctl`”.

Data can also be viewed using the `cat` command with the full path to the file. The form of the `cat` command is similar to that of the `lctl get_param` command with some differences. Unfortunately, as the Linux kernel has changed over the years, the location of statistics and parameter files has also changed, which means that the Lustre parameter files may be located in either the `/proc` directory, in the `/sys` directory, and/or in the `/sys/kernel/debug` directory, depending on the kernel version and the Lustre version being used. The `lctl` command insulates scripts from these changes and is preferred over direct file access, unless as part of a high-performance monitoring system.

Introduced in before Lustre 2.5

Note

Starting in Lustre 2.12, there is `lctl get_param` and `lctl set_param` command can provide *tab completion* when using an interactive shell with `bash-completion` installed. This simplifies the use of `get_param` significantly, since it provides an interactive list of available parameters.

The `llstat` utility can be used to monitor some Lustre file system I/O activity over a specified time period. For more details, see Section 44.6, “`llstat`”

Some data is imported from attached clients and is available in a directory called `exports` located in the corresponding per-service directory on a Lustre server. For example:

```
oss:/root# lctl list_param obdfilter.testfs-OST0000.exports.*
# hash ldlm_stats stats uuid
```

39.1.1. Identifying Lustre File Systems and Servers

Several parameter files on the MGS list existing Lustre file systems and file system servers. The examples below are for a Lustre file system called `testfs` with one MDT and three OSTs.

- To view all known Lustre file systems, enter:

```
mgs# lctl get_param mgs.*.filesystems
testfs
```

- To view the names of the servers in a file system in which least one server is running, enter:

```
lctl get_param mgs.*.live.<filesystem name>
```

For example:

```
mgs# lctl get_param mgs.*.live.testfs
fsname: testfs
flags: 0x20      gen: 45
testfs-MDT0000
testfs-OST0000
testfs-OST0001
testfs-OST0002
```

Secure RPC Config Rules:

```
imperative_recovery_state:
  state: startup
  nonir_clients: 0
  nidtbl_version: 6
  notify_duration_total: 0.001000
  notify_duation_max: 0.001000
  notify_count: 4
```

- To list all configured devices on the local node, enter:

```
# lctl device_list
0 UP mgs MGS MGS 11
1 UP mgc MGC192.168.10.34@tcp 1f45bb57-d9be-2ddb-c0b0-5431a49226705
2 UP mdt MDS MDS_uuid 3
3 UP lov testfs-mdtlov testfs-mdtlov_UUID 4
4 UP mds testfs-MDT0000 testfs-MDT0000_UUID 7
5 UP osc testfs-OST0000-osc testfs-mdtlov_UUID 5
6 UP osc testfs-OST0001-osc testfs-mdtlov_UUID 5
7 UP lov testfs-clilov-ce63ca00 08ac6584-6c4a-3536-2c6d-b36cf9cbdaa04
8 UP mdc testfs-MDT0000-mdc-ce63ca00 08ac6584-6c4a-3536-2c6d-b36cf9cbdaa05
9 UP osc testfs-OST0000-osc-ce63ca00 08ac6584-6c4a-3536-2c6d-b36cf9cbdaa05
10 UP osc testfs-OST0001-osc-ce63ca00 08ac6584-6c4a-3536-2c6d-b36cf9cbdaa05
```

The information provided on each line includes:

- Device number
- Device status (UP, INActive, or STopping)
- Device name
- Device UUID
- Reference count (how many users this device has)

- To display the name of any server, view the device label:

```
mgs# e2label /dev/sda
testfs-MDT0000
```

39.2. Tuning Multi-Block Allocation (mballoc)

Capabilities supported by `mballoc` include:

- Pre-allocation for single files to help to reduce fragmentation.
- Pre-allocation for a group of files to enable packing of small files into large, contiguous chunks.
- Stream allocation to help decrease the seek rate.

The following `mballoc` tunables are available:

Field	Description
<code>mb_max_to_scan</code>	Maximum number of free chunks that <code>mballoc</code> finds before a final decision to avoid a livelock situation.
<code>mb_min_to_scan</code>	Minimum number of free chunks that <code>mballoc</code> searches before picking the best chunk for allocation. This is useful for small requests to reduce fragmentation of big free chunks.
<code>mb_order2_req</code>	For requests equal to 2^N , where $N \geq \text{mb_order2_req}$, a fast search is done using a base 2 buddy allocation service.
<code>mb_small_req</code>	<code>mb_small_req</code> - Defines (in MB) the upper bound of "small requests".
<code>mb_large_req</code>	<code>mb_large_req</code> - Defines (in MB) the lower bound of "large requests". Requests are handled differently based on size: <ul style="list-style-type: none"> • $< \text{mb_small_req}$ - Requests are packed together to form large, aggregated requests. • $> \text{mb_small_req}$ and $< \text{mb_large_req}$ - Requests are primarily allocated linearly. • $> \text{mb_large_req}$ - Requests are allocated since hard disk seek time is less of a concern in this case. <p>In general, small requests are combined to create larger requests, which are then placed close to one another to minimize the number of seeks required to access the data.</p>
<code>prealloc_table</code>	A table of values used to preallocate space when a new request is received. By default, the table looks like this: <pre>prealloc_table 4 8 16 32 64 128 256 512 1024 2048</pre> <p>When a new request is received, space is preallocated at the next higher increment specified in the table. For example, for requests of less than 4 file system blocks, 4 blocks of space are preallocated; for requests between 4 and 8, 8 blocks are preallocated; and so forth</p>

Field	Description
	Although customized values can be entered in the table, the performance of general usage file systems will not typically be improved by modifying the table (in fact, in ext4 systems, the table values are fixed). However, for some specialized workloads, tuning the <code>prealloc_table</code> values may result in smarter preallocation decisions.
<code>mb_group_prealloc</code>	The amount of space (in kilobytes) preallocated for groups of small requests.

Buddy group cache information found in `/sys/fs/ldiskfs/disk_device/mb_groups` may be useful for assessing on-disk fragmentation. For example:

```
cat /proc/fs/ldiskfs/loop0/mb_groups
#group: free free frags first pa [ 2^0 2^1 2^2 2^3 2^4 2^5 2^6 2^7 2^8 2^9
      2^10 2^11 2^12 2^13 ]
#0    : 2936 2936 1    42    0 [ 0  0  0  1  1  1  1  2  0  1
      2    0  0  0  ]
```

In this example, the columns show:

- #group number
- Available blocks in the group
- Blocks free on a disk
- Number of free fragments
- First free block in the group
- Number of preallocated chunks (not blocks)
- A series of available chunks of different sizes

39.3. Monitoring Lustre File System I/O

A number of system utilities are provided to enable collection of data related to I/O activity in a Lustre file system. In general, the data collected describes:

- Data transfer rates and throughput of inputs and outputs external to the Lustre file system, such as network requests or disk I/O operations performed
- Data about the throughput or transfer rates of internal Lustre file system data, such as locks or allocations.

Note

It is highly recommended that you complete baseline testing for your Lustre file system to determine normal I/O activity for your hardware, network, and system workloads. Baseline data will allow you to easily determine when performance becomes degraded in your system. Two particularly useful baseline statistics are:

- `brw_stats` – Histogram data characterizing I/O requests to the OSTs. For more details, see Section 39.3.5, “Monitoring the OST Block I/O Stream”.

- `rpc_stats` – Histogram data showing information about RPCs made by clients. For more details, see Section 39.3.1, “Monitoring the Client RPC Stream”.

39.3.1. Monitoring the Client RPC Stream

The `rpc_stats` file contains histogram data showing information about remote procedure calls (RPCs) that have been made since this file was last cleared. The histogram data can be cleared by writing any value into the `rpc_stats` file.

Example:

```
# lctl get_param osc.testfs-OST0000-osc-ffff810058d2f800.rpc_stats
snapshot_time:          1372786692.389858 (secs.usecs)
read RPCs in flight:    0
write RPCs in flight:   1
dio read RPCs in flight: 0
dio write RPCs in flight: 0
pending write pages:    256
pending read pages:     0
```

pages per rpc	read				write		
	rpcs	%	cum %		rpcs	%	cum %
1:	0	0	0		0	0	0
2:	0	0	0		1	0	0
4:	0	0	0		0	0	0
8:	0	0	0		0	0	0
16:	0	0	0		0	0	0
32:	0	0	0		2	0	0
64:	0	0	0		2	0	0
128:	0	0	0		5	0	0
256:	850	100	100		18346	99	100

rpcs in flight	read				write		
	rpcs	%	cum %		rpcs	%	cum %
0:	691	81	81		1740	9	9
1:	48	5	86		938	5	14
2:	29	3	90		1059	5	20
3:	17	2	92		1052	5	26
4:	13	1	93		920	5	31
5:	12	1	95		425	2	33
6:	10	1	96		389	2	35
7:	30	3	100		11373	61	97
8:	0	0	100		460	2	100

offset	read				write		
	rpcs	%	cum %		rpcs	%	cum %
0:	850	100	100		18347	99	99
1:	0	0	100		0	0	99
2:	0	0	100		0	0	99
4:	0	0	100		0	0	99
8:	0	0	100		0	0	99
16:	0	0	100		1	0	99
32:	0	0	100		1	0	99
64:	0	0	100		3	0	99

128: 0 0 100 | 4 0 100

The header information includes:

- `snapshot_time` - UNIX epoch instant the file was read.
- `read RPCs in flight` - Number of read RPCs issued by the OSC, but not complete at the time of the snapshot. This value should always be less than or equal to `max_rpcs_in_flight`.
- `write RPCs in flight` - Number of write RPCs issued by the OSC, but not complete at the time of the snapshot. This value should always be less than or equal to `max_rpcs_in_flight`.
- `dio read RPCs in flight` - Direct I/O (as opposed to block I/O) read RPCs issued but not completed at the time of the snapshot.
- `dio write RPCs in flight` - Direct I/O (as opposed to block I/O) write RPCs issued but not completed at the time of the snapshot.
- `pending write pages` - Number of pending write pages that have been queued for I/O in the OSC.
- `pending read pages` - Number of pending read pages that have been queued for I/O in the OSC.

The tabular data is described in the table below. Each row in the table shows the number of reads or writes (`ios`) occurring for the statistic, the relative percentage (%) of total reads or writes, and the cumulative percentage (`cum %`) to that point in the table for the statistic.

Field	Description
pages per RPC	Shows cumulative RPC reads and writes organized according to the number of pages in the RPC. A single page RPC increments the 0 : row.
RPCs in flight	Shows the number of RPCs that are pending when an RPC is sent. When the first RPC is sent, the 0 : row is incremented. If the first RPC is sent while another RPC is pending, the 1 : row is incremented and so on.
offset	The page index of the first page read from or written to the object by the RPC.

Analysis:

This table provides a way to visualize the concurrency of the RPC stream. Ideally, you will see a large clump around the `max_rpcs_in_flight` value, which shows that the network is being kept busy.

For information about optimizing the client I/O RPC stream, see Section 39.4.1, “Tuning the Client I/O RPC Stream”.

39.3.2. Monitoring Client Activity

The `stats` file maintains statistics accumulate during typical operation of a client across the VFS interface of the Lustre file system. Only non-zero parameters are displayed in the file.

Client statistics are enabled by default.

Note

Statistics for all mounted file systems can be discovered by entering:

```
lctl get_param llite.*.stats
```

Example:

```
client# lctl get_param llite.*.stats
snapshot_time      1308343279.169704 secs.usecs
dirty_pages_hits   14819716 samples [regs]
dirty_pages_misses 81473472 samples [regs]
read_bytes         36502963 samples [bytes] 1 26843582 55488794
write_bytes        22985001 samples [bytes] 0 125912 3379002
brw_read           2279 samples [pages] 1 1 2270
ioctl              186749 samples [regs]
open               3304805 samples [regs]
close              3331323 samples [regs]
seek               48222475 samples [regs]
fsync              963 samples [regs]
truncate           9073 samples [regs]
setxattr           19059 samples [regs]
getxattr           61169 samples [regs]
```

The statistics can be cleared by echoing an empty string into the `stats` file or by using the command:

```
lctl set_param llite.*.stats=0
```

The statistics displayed are described in the table below.

Entry	Description						
<code>snapshot_time</code>	UNIX epoch instant the stats file was read.						
<code>dirty_page_hits</code>	The number of write operations that have been satisfied by the dirty page cache. See Section 39.4.1, “Tuning the Client I/O RPC Stream” for more information about dirty cache behavior in a Lustre file system.						
<code>dirty_page_misses</code>	The number of write operations that were not satisfied by the dirty page cache.						
<code>read_bytes</code>	The number of read operations that have occurred. Three additional parameters are displayed: <table> <tr> <td>min</td> <td>The minimum number of bytes read in a single request since the counter was reset.</td> </tr> <tr> <td>max</td> <td>The maximum number of bytes read in a single request since the counter was reset.</td> </tr> <tr> <td>sum</td> <td>The accumulated sum of bytes of all read requests since the counter was reset.</td> </tr> </table>	min	The minimum number of bytes read in a single request since the counter was reset.	max	The maximum number of bytes read in a single request since the counter was reset.	sum	The accumulated sum of bytes of all read requests since the counter was reset.
min	The minimum number of bytes read in a single request since the counter was reset.						
max	The maximum number of bytes read in a single request since the counter was reset.						
sum	The accumulated sum of bytes of all read requests since the counter was reset.						
<code>write_bytes</code>	The number of write operations that have occurred. Three additional parameters are displayed: <table> <tr> <td>min</td> <td>The minimum number of bytes written in a single request since the counter was reset.</td> </tr> </table>	min	The minimum number of bytes written in a single request since the counter was reset.				
min	The minimum number of bytes written in a single request since the counter was reset.						

Entry	Description
	<p>max The maximum number of bytes written in a single request since the counter was reset.</p> <p>sum The accumulated sum of bytes of all write requests since the counter was reset.</p>
brw_read	<p>The number of pages that have been read. Three additional parameters are displayed:</p> <p>min The minimum number of bytes read in a single block read/write (brw) read request since the counter was reset.</p> <p>max The maximum number of bytes read in a single brw read requests since the counter was reset.</p> <p>sum The accumulated sum of bytes of all brw read requests since the counter was reset.</p>
ioctl	The number of combined file and directory <code>ioctl</code> operations.
open	The number of open operations that have succeeded.
close	The number of close operations that have succeeded.
seek	The number of times <code>seek</code> has been called.
fsync	The number of times <code>fsync</code> has been called.
truncate	The total number of calls to both locked and lockless <code>truncate</code> .
setxattr	The number of times extended attributes have been set.
getxattr	The number of times value(s) of extended attributes have been fetched.

Analysis:

Information is provided about the amount and type of I/O activity is taking place on the client.

39.3.3. Monitoring Client Read-Write Offset Statistics

When the `offset_stats` parameter is set, statistics are maintained for occurrences of a series of read or write calls from a process that did not access the next sequential location. The `OFFSET` field is reset to 0 (zero) whenever a different file is read or written.

Note

By default, statistics are not collected in the `offset_stats`, `extents_stats`, and `extents_stats_per_process` files to reduce monitoring overhead when this information is not needed. The collection of statistics in all three of these files is activated by writing anything, except for 0 (zero) and "disable", into any one of the files.

Example:

```
# lctl get_param llite.testfs-f57dee0.offset_stats
snapshot_time: 1155748884.591028 (secs.usecs)
      RANGE  RANGE  SMALLEST  LARGEST
R/W  PID    START  END      EXTENT    EXTENT    OFFSET
R    8385   0      128     128      128      0
R    8385   0      224     224      224     -128
```

W	8385	0	250	50	100	0
W	8385	100	1110	10	500	-150
W	8384	0	5233	5233	5233	0
R	8385	500	600	100	100	-610

In this example, `snapshot_time` is the UNIX epoch instant the file was read. The tabular data is described in the table below.

The `offset_stats` file can be cleared by entering:

```
lctl set_param llite.*.offset_stats=0
```

Field	Description
R/W	Indicates if the non-sequential call was a read or write
PID	Process ID of the process that made the read/write call.
RANGE START/RANGE END	Range in which the read/write calls were sequential.
SMALLEST EXTENT	Smallest single read/write in the corresponding range (in bytes).
LARGEST EXTENT	Largest single read/write in the corresponding range (in bytes).
OFFSET	Difference between the previous range end and the current range start.

Analysis:

This data provides an indication of how contiguous or fragmented the data is. For example, the fourth entry in the example above shows the writes for this RPC were sequential in the range 100 to 1110 with the minimum write 10 bytes and the maximum write 500 bytes. The range started with an offset of -150 from the `RANGE END` of the previous entry in the example.

39.3.4. Monitoring Client Read-Write Extent Statistics

For in-depth troubleshooting, client read-write extent statistics can be accessed to obtain more detail about read/write I/O extents for the file system or for a particular process.

Note

By default, statistics are not collected in the `offset_stats`, `extents_stats`, and `extents_stats_per_process` files to reduce monitoring overhead when this information is not needed. The collection of statistics in all three of these files is activated by writing anything, except for 0 (zero) and "disable", into any one of the files.

39.3.4.1. Client-Based I/O Extent Size Survey

The `extents_stats` histogram in the `llite` directory shows the statistics for the sizes of the read/write I/O extents. This file does not maintain the per process statistics.

Example:

```
# lctl get_param llite.testfs-*.extents_stats
snapshot_time: 1213828728.348516 (secs.usecs)
```

extents	read			write		
	calls	%	cum%	calls	%	cum%
0K - 4K :	0	0	0	2	2	2
4K - 8K :	0	0	0	0	0	2
8K - 16K :	0	0	0	0	0	2
16K - 32K :	0	0	0	20	23	26
32K - 64K :	0	0	0	0	0	26
64K - 128K :	0	0	0	51	60	86
128K - 256K :	0	0	0	0	0	86
256K - 512K :	0	0	0	0	0	86
512K - 1024K :	0	0	0	0	0	86
1M - 2M :	0	0	0	11	13	100

In this example, `snapshot_time` is the UNIX epoch instant the file was read. The table shows cumulative extents organized according to size with statistics provided separately for reads and writes. Each row in the table shows the number of RPCs for reads and writes respectively (`calls`), the relative percentage of total calls (%), and the cumulative percentage to that point in the table of calls (`cum %`).

The file can be cleared by issuing the following command:

```
# lctl set_param llite.testfs-*.extents_stats=1
```

39.3.4.2. Per-Process Client I/O Statistics

The `extents_stats_per_process` file maintains the I/O extent size statistics on a per-process basis.

Example:

```
# lctl get_param llite.testfs-*.extents_stats_per_process
snapshot_time: 1213828762.204440 (secs.usecs)
```

extents	read			write		
	calls	%	cum%	calls	%	cum%
PID: 11488						
0K - 4K :	0	0	0	0	0	0
4K - 8K :	0	0	0	0	0	0
8K - 16K :	0	0	0	0	0	0
16K - 32K :	0	0	0	0	0	0
32K - 64K :	0	0	0	0	0	0
64K - 128K :	0	0	0	0	0	0
128K - 256K :	0	0	0	0	0	0
256K - 512K :	0	0	0	0	0	0
512K - 1024K :	0	0	0	0	0	0
1M - 2M :	0	0	0	10	100	100
PID: 11491						
0K - 4K :	0	0	0	0	0	0
4K - 8K :	0	0	0	0	0	0
8K - 16K :	0	0	0	0	0	0
16K - 32K :	0	0	0	20	100	100
PID: 11424						
0K - 4K :	0	0	0	0	0	0

Lustre Parameters

4K - 8K :	0	0	0		0	0	0
8K - 16K :	0	0	0		0	0	0
16K - 32K :	0	0	0		0	0	0
32K - 64K :	0	0	0		0	0	0
64K - 128K :	0	0	0		16	100	100
PID: 11426							
0K - 4K :	0	0	0		1	100	100
PID: 11429							
0K - 4K :	0	0	0		1	100	100

This table shows cumulative extents organized according to size for each process ID (PID) with statistics provided separately for reads and writes. Each row in the table shows the number of RPCs for reads and writes respectively (`calls`), the relative percentage of total calls (%), and the cumulative percentage to that point in the table of calls (`cum %`).

39.3.5. Monitoring the OST Block I/O Stream

The `brw_stats` parameter file below the `osd-ldiskfs` or `osd-zfs` directory contains histogram data showing statistics for number of I/O requests sent to the disk, their size, and whether they are contiguous on the disk or not.

Example:

Enter on the OSS or MDS:

```
oss# lctl get_param osd-*.*.brw_stats
snapshot_time:      1372775039.769045 (secs.usecs)

```

	read					write			
pages per bulk r/w	rpcs	%	cum %	%		rpcs	%	cum %	%
1:	108	100	100			39	0	0	
2:	0	0	100			6	0	0	
4:	0	0	100			1	0	0	
8:	0	0	100			0	0	0	
16:	0	0	100			4	0	0	
32:	0	0	100			17	0	0	
64:	0	0	100			12	0	0	
128:	0	0	100			24	0	0	
256:	0	0	100			23142	99	100	

	read					write			
discontiguous pages	rpcs	%	cum %	%		rpcs	%	cum %	%
0:	108	100	100			23245	100	100	

	read					write			
discontiguous blocks	rpcs	%	cum %	%		rpcs	%	cum %	%
0:	108	100	100			23243	99	99	
1:	0	0	100			2	0	100	

	read					write			
disk fragmented I/Os	ios	%	cum %	%		ios	%	cum %	%
0:	94	87	87			0	0	0	
1:	14	12	100			23243	99	99	

Lustre Parameters

	read			write		
disk I/Os in flight	ios	%	cum %	ios	%	cum %
2:	0	0	100	2	0	100
1:	14	100	100	20896	89	89
2:	0	0	100	1071	4	94
3:	0	0	100	573	2	96
4:	0	0	100	300	1	98
5:	0	0	100	166	0	98
6:	0	0	100	108	0	99
7:	0	0	100	81	0	99
8:	0	0	100	47	0	99
9:	0	0	100	5	0	100

	read			write		
I/O time (1/1000s)	ios	%	cum %	ios	%	cum %
1:	94	87	87	0	0	0
2:	0	0	87	7	0	0
4:	14	12	100	27	0	0
8:	0	0	100	14	0	0
16:	0	0	100	31	0	0
32:	0	0	100	38	0	0
64:	0	0	100	18979	81	82
128:	0	0	100	943	4	86
256:	0	0	100	1233	5	91
512:	0	0	100	1825	7	99
1K:	0	0	100	99	0	99
2K:	0	0	100	0	0	99
4K:	0	0	100	0	0	99
8K:	0	0	100	49	0	100

	read			write		
disk I/O size	ios	%	cum %	ios	%	cum %
4K:	14	100	100	41	0	0
8K:	0	0	100	6	0	0
16K:	0	0	100	1	0	0
32K:	0	0	100	0	0	0
64K:	0	0	100	4	0	0
128K:	0	0	100	17	0	0
256K:	0	0	100	12	0	0
512K:	0	0	100	24	0	0
1M:	0	0	100	23142	99	100

The tabular data is described in the table below. Each row in the table shows the number of reads and writes occurring for the statistic (*ios*), the relative percentage of total reads or writes (%), and the cumulative percentage to that point in the table for the statistic (*cum %*).

Field	Description
pages per bulk r/w	Number of pages per RPC request, which should match aggregate client <i>rpc_stats</i> (see Section 39.3.1, “Monitoring the Client RPC Stream”).
discontiguous pages	Number of discontinuities in the logical file offset of each page in a single RPC.

Field	Description
discontiguous blocks	Number of discontinuities in the physical block allocation in the file system for a single RPC.
disk fragmented I/Os	Number of I/Os that were not written entirely sequentially.
disk I/Os in flight	Number of disk I/Os currently pending.
I/O time (1/1000s)	Amount of time for each I/O operation to complete.
disk I/O size	Size of each I/O operation.

Analysis:

This data provides an indication of extent size and distribution in the file system.

39.4. Tuning Lustre File System I/O

Each OSC has its own tree of tunables. For example:

```
$ lctl lctl list_param osc.*.*
osc.myth-OST0000-osc-ffff8804296c2800.active
osc.myth-OST0000-osc-ffff8804296c2800.blocksize
osc.myth-OST0000-osc-ffff8804296c2800.checksum_dump
osc.myth-OST0000-osc-ffff8804296c2800.checksum_type
osc.myth-OST0000-osc-ffff8804296c2800.checksums
osc.myth-OST0000-osc-ffff8804296c2800.connect_flags
:
:
osc.myth-OST0000-osc-ffff8804296c2800.state
osc.myth-OST0000-osc-ffff8804296c2800.stats
osc.myth-OST0000-osc-ffff8804296c2800.timeouts
osc.myth-OST0000-osc-ffff8804296c2800.unstable_stats
osc.myth-OST0000-osc-ffff8804296c2800.uuid
osc.myth-OST0001-osc-ffff8804296c2800.active
osc.myth-OST0001-osc-ffff8804296c2800.blocksize
osc.myth-OST0001-osc-ffff8804296c2800.checksum_dump
osc.myth-OST0001-osc-ffff8804296c2800.checksum_type
:
:
```

The following sections describe some of the parameters that can be tuned in a Lustre file system.

39.4.1. Tuning the Client I/O RPC Stream

Ideally, an optimal amount of data is packed into each I/O RPC and a consistent number of issued RPCs are in progress at any time. To help optimize the client I/O RPC stream, several tuning variables are provided to adjust behavior according to network conditions and cluster size. For information about monitoring the client I/O RPC stream, see Section 39.3.1, “Monitoring the Client RPC Stream”.

RPC stream tunables include:

- `osc.osc_instance.checksums` - Controls whether the client will calculate data integrity checksums for the bulk data transferred to the OST. Data integrity checksums are enabled by default. The algorithm used can be set using the `checksum_type` parameter.

- `osc.osc_instance.checksum_type` - Controls the data integrity checksum algorithm used by the client. The available algorithms are determined by the set of algorithms. The checksum algorithm used by default is determined by first selecting the fastest algorithms available on the OST, and then selecting the fastest of those algorithms on the client, which depends on available optimizations in the CPU hardware and kernel. The default algorithm can be overridden by writing the algorithm name into the `checksum_type` parameter. Available checksum types can be seen on the client by reading the `checksum_type` parameter. Currently supported checksum types are: `adler`, `crc32`, `crc32c`

Introduced in Lustre 2.12

In Lustre release 2.12 additional checksum types were added to allow end-to-end checksum integration with T10-PI capable hardware. The client will compute the appropriate checksum type, based on the checksum type used by the storage, for the RPC checksum, which will be verified by the server and passed on to the storage. The T10-PI checksum types are: `t10ip512`, `t10ip4K`, `t10crc512`, `t10crc4K`

- `osc.osc_instance.max_dirty_mb` - Controls how many MiB of dirty data can be written into the client pagecache for writes by *each* OSC. When this limit is reached, additional writes block until previously-cached data is written to the server. This may be changed by the `lctl set_param` command. Only values larger than 0 and smaller than the lesser of 2048 MiB or 1/4 of client RAM are valid. Performance can suffer if the client cannot aggregate enough data per OSC to form a full RPC (as set by the `max_pages_per_rpc`) parameter, unless the application is doing very large writes itself.

To maximize performance, the value for `max_dirty_mb` is recommended to be at least $4 * \text{max_pages_per_rpc} * \text{max_rpcs_in_flight}$.

- `osc.osc_instance.cur_dirty_bytes` - A read-only value that returns the current number of bytes written and cached by this OSC.
- `osc.osc_instance.max_pages_per_rpc` - The maximum number of pages that will be sent in a single RPC request to the OST. The minimum value is one page and the maximum value is 16 MiB (4096 on systems with `PAGE_SIZE` of 4 KiB), with the default value of 4 MiB in one RPC. The upper limit may also be constrained by `ofd.*.brw_size` setting on the OSS, and applies to all clients connected to that OST. It is also possible to specify a units suffix (e.g. `max_pages_per_rpc=4M`), so the RPC size can be set independently of the client `PAGE_SIZE`.
- `osc.osc_instance.max_rpcs_in_flight` - The maximum number of concurrent RPCs in flight from an OSC to its OST. If the OSC tries to initiate an RPC but finds that it already has the same number of RPCs outstanding, it will wait to issue further RPCs until some complete. The minimum setting is 1 and maximum setting is 256. The default value is 8 RPCs.

To improve small file I/O performance, increase the `max_rpcs_in_flight` value.

- `llite.fsname_instance.max_cached_mb` - Maximum amount of read+write data cached by the client. The default value is 1/2 of the client RAM.

Note

The value for `osc_instance` and `fsname_instance` are unique to each mount point to allow associating `osc`, `mdc`, `lov`, `lmv`, and `llite` parameters with the same mount point. However, it is common for scripts to use a wildcard `*` or a filesystem-specific wildcard `fsname-*` to specify the parameter settings uniformly on all clients. For example:

```
client$ lctl get_param osc.testfs-OST0000*.rpc_stats
```

```
osc.testfs-OST0000-osc-ffff88107412f400.rpc_stats=  
snapshot_time:      1375743284.337839 (secs.usecs)  
read RPCs in flight: 0  
write RPCs in flight: 0
```

39.4.2. Tuning File Readahead and Directory Statahead

File readahead and directory statahead enable reading of data into memory before a process requests the data. File readahead prefetches file content data into memory for `read()` related calls, while directory statahead fetches file metadata into memory for `readdir()` and `stat()` related calls. When readahead and statahead work well, a process that accesses data finds that the information it needs is available immediately in memory on the client when requested without the delay of network I/O.

39.4.2.1. Tuning File Readahead

File readahead is triggered when two or more sequential reads by an application fail to be satisfied by data in the Linux buffer cache. The size of the initial readahead is determined by the RPC size and the file stripe size, but will typically be at least 1 MiB. Additional readaheads grow linearly and increment until the per-file or per-system readahead cache limit on the client is reached.

Readahead tunables include:

- `llite.fsname_instance.max_read_ahead_mb` - Controls the maximum amount of data readahead on all files. Files are read ahead in RPC-sized chunks (4 MiB, or the size of the `read()` call, if larger) after the second sequential read on a file descriptor. Random reads are done at the size of the `read()` call only (no readahead). Reads to non-contiguous regions of the file reset the readahead algorithm, and readahead is not triggered until sequential reads take place again.

This is the global limit for all files and cannot be larger than 1/2 of the client RAM. To disable readahead, set `max_read_ahead_mb=0`.

- `llite.fsname_instance.max_read_ahead_per_file_mb` - Controls the maximum number of megabytes (MiB) of data that should be prefetched by the client when sequential reads are detected on one file. This is the per-file readahead limit and cannot be larger than `max_read_ahead_mb`.
- `llite.fsname_instance.max_read_ahead_whole_mb` - Controls the maximum size of a file in MiB that is read in its entirety upon access, regardless of the size of the `read()` call. This avoids multiple small read RPCs on relatively small files, when it is not possible to efficiently detect a sequential read pattern before the whole file has been read.

The default value is the greater of 2 MiB or the size of one RPC, as given by `max_pages_per_rpc`.

39.4.2.2. Tuning Directory Statahead and AGL

Many system commands, such as `ls -l`, `du`, and `find`, traverse a directory sequentially. To make these commands run efficiently, the directory statahead can be enabled to improve the performance of directory traversal.

The statahead tunables are:

- `statahead_max` - Controls the maximum number of file attributes that will be prefetched by the statahead thread. By default, statahead is enabled and `statahead_max` is 32 files.

To disable statahead, set `statahead_max` to zero via the following command on the client:

```
lctl set_param llite.*.statahead_max=0
```

To change the maximum statahead window size on a client:

```
lctl set_param llite.*.statahead_max=n
```

The maximum `statahead_max` is 8192 files.

The directory `statahead` thread will also prefetch the file size/block attributes from the OSTs, so that all file attributes are available on the client when requested by an application. This is controlled by the asynchronous glimpse lock (AGL) setting. The AGL behaviour can be disabled by setting:

```
lctl set_param llite.*.statahead_agl=0
```

- `statahead_stats` - A read-only interface that provides current `statahead` and AGL statistics, such as how many times `statahead`/AGL has been triggered since the last mount, how many `statahead`/AGL failures have occurred due to an incorrect prediction or other causes.

Note

AGL behaviour is affected by `statahead` since the inodes processed by AGL are built by the `statahead` thread. If `statahead` is disabled, then AGL is also disabled.

39.4.3. Tuning Server Read Cache

The server read cache feature provides read-only caching of file data on an OSS or MDS (for Data-on-MDT). This functionality uses the Linux page cache to store the data and uses as much physical memory as is allocated.

The server read cache can improve Lustre file system performance in these situations:

- Many clients are accessing the same data set (as in HPC applications or when diskless clients boot from the Lustre file system).
- One client is writing data while another client is reading it (i.e., clients are exchanging data via the filesystem).
- A client has very limited caching of its own.

The server read cache offers these benefits:

- Allows servers to cache read data more frequently.
- Improves repeated reads to match network speeds instead of storage speeds.
- Provides the building blocks for server write cache (small-write aggregation).

39.4.3.1. Using Server Read Cache

The server read cache is implemented on the OSS and MDS, and does not require any special support on the client side. Since the server read cache uses the memory available in the Linux page cache, the appropriate amount of memory for the cache should be determined based on I/O patterns. If the data is mostly reads, then more cache is beneficial on the server than would be needed for mostly writes.

The server read cache is managed using the following tunables. Many tunables are available for both `osd-ldiskfs` and `osd-zfs`, but in some cases the implementation of `osd-zfs` prevents their use.

- `read_cache_enable` - High-level control of whether data read from storage during a read request is kept in memory and available for later read requests for the same data, without having to re-read it from storage. By default, read cache is enabled (`read_cache_enable=1`) for HDD OSDs and automatically disabled for flash OSDs (`nonrotational=1`). The read cache cannot be disabled for `osd-zfs`, and as a result this parameter is unavailable for that backend.

When the server receives a read request from a client, it reads data from storage into its memory and sends the data to the client. If read cache is enabled for the target, and the RPC and object size also meet the other criterion below, this data may stay in memory after the client request has completed. If later read requests for the same data are received, if the data is still in cache the server skips reading it from storage. The cache is managed by the Linux kernel globally across all targets on that server so that the infrequently used cache pages are dropped from memory when the free memory is running low.

If read cache is disabled (`read_cache_enable=0`), or the read or object is large enough that it will not benefit from caching, the server discards the data after the read request from the client is completed. For subsequent read requests the server again reads the data from storage.

To disable read cache on all targets of a server, run:

```
ossl# lctl set_param osd-*.*.read_cache_enable=0
```

To re-enable read cache on one target, run:

```
ossl# lctl set_param osd-*. {target_name}.read_cache_enable=1
```

To check if read cache is enabled on targets on a server, run:

```
ossl# lctl get_param osd-*.*.read_cache_enable
```

- `writethrough_cache_enable` - High-level control of whether data sent to the server as a write request is kept in the read cache and available for later reads, or if it is discarded when the write completes. By default, writethrough cache is enabled (`writethrough_cache_enable=1`) for HDD OSDs and automatically disabled for flash OSDs (`nonrotational=1`). The write cache cannot be disabled for `osd-zfs`, and as a result this parameter is unavailable for that backend.

When the server receives write requests from a client, it fetches data from the client into its memory and writes the data to storage. If the writethrough cache is enabled for the target, and the RPC and object size meet the other criterion below, this data may stay in memory after the write request has completed. If later read or partial-block write requests for this same data are received, if the data is still in cache the server skips reading it from storage.

If the writethrough cache is disabled (`writethrough_cache_enabled=0`), or the write or object is large enough that it will not benefit from caching, the server discards the data after the write request from the client is completed. For subsequent read requests, or partial-page write requests, the server must re-read the data from storage.

Enabling writethrough cache is advisable if clients are doing small or unaligned writes that would cause partial-page updates, or if the files written by one node are immediately being read by other nodes. Some examples where enabling writethrough cache might be useful include producer-consumer I/O models or shared-file writes that are not aligned on 4096-byte boundaries.

Disabling the writethrough cache is advisable when files are mostly written to the file system but are not re-read within a short time period, or files are only written and re-read by the same node, regardless of whether the I/O is aligned or not.

To disable writethrough cache on all targets on a server, run:

```
oss1# lctl set_param osd-*.*.writethrough_cache_enable=0
```

To re-enable the writethrough cache on one OST, run:

```
oss1# lctl set_param osd-*. {OST_name}.writethrough_cache_enable=1
```

To check if the writethrough cache is enabled, run:

```
oss1# lctl get_param osd-*.*.writethrough_cache_enable
```

- `readcache_max_filesize` - Controls the maximum size of an object that both the read cache and writethrough cache will try to keep in memory. Objects larger than `readcache_max_filesize` will not be kept in cache for either reads or writes regardless of the `read_cache_enable` or `writethrough_cache_enable` settings.

Setting this tunable can be useful for workloads where relatively small objects are repeatedly accessed by many clients, such as job startup objects, executables, log objects, etc., but large objects are read or written only once. By not putting the larger objects into the cache, it is much more likely that more of the smaller objects will remain in cache for a longer time.

When setting `readcache_max_filesize`, the input value can be specified in bytes, or can have a suffix to indicate other binary units such as K (kibibytes), M (mebibytes), G (gibibytes), T (tebibytes), or P (pebibytes).

To limit the maximum cached object size to 64 MiB on all OSTs of a server, run:

```
oss1# lctl set_param osd-*.*.readcache_max_filesize=64M
```

To disable the maximum cached object size on all targets, run:

```
oss1# lctl set_param osd-*.*.readcache_max_filesize=-1
```

To check the current maximum cached object size on all targets of a server, run:

```
oss1# lctl get_param osd-*.*.readcache_max_filesize
```

- `readcache_max_io_mb` - Controls the maximum size of a single read IO that will be cached in memory. Reads larger than `readcache_max_io_mb` will be read directly from storage and bypass

the page cache completely. This avoids significant CPU overhead at high IO rates. The read cache cannot be disabled for `osd-zfs`, and as a result this parameter is unavailable for that backend.

When setting `readcache_max_io_mb`, the input value can be specified in mebibytes, or can have a suffix to indicate other binary units such as K (kibibytes), M (mebibytes), G (gibibytes), T (tebibytes), or P (pebibytes).

- `writethrough_max_io_mb` - Controls the maximum size of a single writes IO that will be cached in memory. Writes larger than `writethrough_max_io_mb` will be written directly to storage and bypass the page cache entirely. This avoids significant CPU overhead at high IO rates. The write cache cannot be disabled for `osd-zfs`, and as a result this parameter is unavailable for that backend.

When setting `writethrough_max_io_mb`, the input value can be specified in mebibytes, or can have a suffix to indicate other binary units such as K (kibibytes), M (mebibytes), G (gibibytes), T (tebibytes), or P (pebibytes).

39.4.4. Enabling OSS Asynchronous Journal Commit

The OSS asynchronous journal commit feature asynchronously writes data to disk without forcing a journal flush. This reduces the number of seeks and significantly improves performance on some hardware.

Note

Asynchronous journal commit cannot work with direct I/O-originated writes (`O_DIRECT` flag set). In this case, a journal flush is forced.

When the asynchronous journal commit feature is enabled, client nodes keep data in the page cache (a page reference). Lustre clients monitor the last committed transaction number (`transno`) in messages sent from the OSS to the clients. When a client sees that the last committed `transno` reported by the OSS is at least equal to the bulk write `transno`, it releases the reference on the corresponding pages. To avoid page references being held for too long on clients after a bulk write, a 7 second ping request is scheduled (the default OSS file system commit time interval is 5 seconds) after the bulk write reply is received, so the OSS has an opportunity to report the last committed `transno`.

If the OSS crashes before the journal commit occurs, then intermediate data is lost. However, OSS recovery functionality incorporated into the asynchronous journal commit feature causes clients to replay their write requests and compensate for the missing disk updates by restoring the state of the file system.

By default, `sync_journal` is enabled (`sync_journal=1`), so that journal entries are committed synchronously. To enable asynchronous journal commit, set the `sync_journal` parameter to 0 by entering:

```
$ lctl set_param obdfilter.*.sync_journal=0
obdfilter.lol-OST0001.sync_journal=0
```

An associated `sync-on-lock-cancel` feature (enabled by default) addresses a data consistency issue that can result if an OSS crashes after multiple clients have written data into intersecting regions of an object, and then one of the clients also crashes. A condition is created in which the POSIX requirement for continuous writes is violated along with a potential for corrupted data. With `sync-on-lock-cancel` enabled, if a cancelled lock has any volatile writes attached to it, the OSS synchronously writes the journal to disk on lock cancellation. Disabling the `sync-on-lock-cancel` feature may enhance performance for concurrent write workloads, but it is recommended that you not disable this feature.

The `sync_on_lock_cancel` parameter can be set to the following values:

- `always` - Always force a journal flush on lock cancellation (default when `async_journal` is enabled).
- `blocking` - Force a journal flush only when the local cancellation is due to a blocking callback.
- `never` - Do not force any journal flush (default when `async_journal` is disabled).

For example, to set `sync_on_lock_cancel` to not to force a journal flush, use a command similar to:

```
$ lctl get_param obdfilter.*.sync_on_lock_cancel
obdfilter.lol-OST0001.sync_on_lock_cancel=never
```

Introduced in Lustre 2.8

39.4.5. Tuning the Client Metadata RPC Stream

The client metadata RPC stream represents the metadata RPCs issued in parallel by a client to a MDT target. The metadata RPCs can be split in two categories: the requests that do not modify the file system (like `getattr` operation), and the requests that do modify the file system (like `create`, `unlink`, `setattr` operations). To help optimize the client metadata RPC stream, several tuning variables are provided to adjust behavior according to network conditions and cluster size.

Note that increasing the number of metadata RPCs issued in parallel might improve the performance metadata intensive parallel applications, but as a consequence it will consume more memory on the client and on the MDS.

39.4.5.1. Configuring the Client Metadata RPC Stream

The MDC `max_rpcs_in_flight` parameter defines the maximum number of metadata RPCs, both modifying and non-modifying RPCs, that can be sent in parallel by a client to a MDT target. This includes every file system metadata operations, such as file or directory `stat`, `creation`, `unlink`. The default setting is 8, minimum setting is 2 and maximum setting is 512.

To set the `max_rpcs_in_flight` parameter, run the following command on the Lustre client:

```
client$ lctl set_param mdc.*.max_rpcs_in_flight=16
```

The MDC `max_mod_rpcs_in_flight` parameter defines the maximum number of file system modifying RPCs that can be sent in parallel by a client to a MDT target. For example, the Lustre client sends `modify` RPCs when it performs file or directory `creation`, `unlink`, `access permission modification` or `ownership modification`. The default setting is 7, minimum setting is 1 and maximum setting is 511.

To set the `max_mod_rpcs_in_flight` parameter, run the following command on the Lustre client:

```
client$ lctl set_param mdc.*.max_mod_rpcs_in_flight=12
```

The `max_mod_rpcs_in_flight` value must be strictly less than the `max_rpcs_in_flight` value. It must also be less or equal to the MDT `max_mod_rpcs_per_client` value. If one of these conditions is not enforced, the setting fails and an explicit message is written in the Lustre log.

The MDT `max_mod_rpcs_per_client` parameter is a tunable of the kernel module `mdt` that defines the maximum number of file system modifying RPCs in flight allowed per client. The parameter can be updated at runtime, but the change is effective to new client connections only. The default setting is 8.

To set the `max_mod_rpcs_per_client` parameter, run the following command on the MDS:

```
mds$ echo 12 > /sys/module/mdt/parameters/max_mod_rpcs_per_client
```

39.4.5.2. Monitoring the Client Metadata RPC Stream

The `rpc_stats` file contains histogram data showing information about modify metadata RPCs. It can be helpful to identify the level of parallelism achieved by an application doing modify metadata operations.

Example:

```
client$ lctl get_param mdc.*.rpc_stats
snapshot_time:      1441876896.567070 (secs.usecs)
modify_RPCs_in_flight:  0
```

rpcs in flight	modify		
	rpcs	%	cum %
0:	0	0	0
1:	56	0	0
2:	40	0	0
3:	70	0	0
4:	41	0	0
5:	51	0	1
6:	88	0	1
7:	366	1	2
8:	1321	5	8
9:	3624	15	23
10:	6482	27	50
11:	7321	30	81
12:	4540	18	100

The file information includes:

- `snapshot_time` - UNIX epoch instant the file was read.
- `modify_RPCs_in_flight` - Number of modify RPCs issued by the MDC, but not completed at the time of the snapshot. This value should always be less than or equal to `max_mod_rpc_in_flight`.
- `rpcs in flight` - Number of modify RPCs that are pending when a RPC is sent, the relative percentage (%) of total modify RPCs, and the cumulative percentage (cum %) to that point.

If a large proportion of modify metadata RPCs are issued with a number of pending metadata RPCs close to the `max_mod_rpc_in_flight` value, it means the `max_mod_rpc_in_flight` value could be increased to improve the modify metadata performance.

39.5. Configuring Timeouts in a Lustre File System

In a Lustre file system, RPC timeouts are set using an adaptive timeouts mechanism, which is enabled by default. Servers track RPC completion times and then report back to clients estimates for completion times for future RPCs. Clients use these estimates to set RPC timeout values. If the processing of server requests slows down for any reason, the server estimates for RPC completion increase, and clients then revise RPC timeout values to allow more time for RPC completion.

If the RPCs queued on the server approach the RPC timeout specified by the client, to avoid RPC timeouts and disconnect/reconnect cycles, the server sends an "early reply" to the client, telling the client to allow more time. Conversely, as server processing speeds up, RPC timeout values decrease, resulting in faster detection if the server becomes non-responsive and quicker connection to the failover partner of the server.

39.5.1. Configuring Adaptive Timeouts

The adaptive timeout parameters in the table below can be set persistently system-wide using `lctl set_param -P` on the MGS. For example, the following command sets the `at_max` value for all servers and clients associated with the file systems connected to this MGS:

```
mgs# lctl set_param -P at_max=1500
```

Note

Clients that access multiple Lustre file systems *must* use the same adaptive timeout values for all file systems.

Introduced in Lustre 2.16

Since Lustre 2.16 it is preferred to set `at_min` as a per-target tunable using the `*.fsname*.at_min` parameter instead of the global `at_min` parameter. This avoids issues if a single client mounts two separate filesystems with different `at_min` tunable settings.

```
mgs# lctl set_param -P *.testfs-*.at_max=1500
```

Parameter	Description
<code>at_min</code>	<p>Minimum adaptive timeout (in seconds). The default value is 5 (since 2.16). The <code>at_min</code> parameter is the minimum processing time that a server will report. Ideally, <code>at_min</code> should be left at its default value. Clients base their timeouts on this value, but they do not use this value directly.</p> <p>If, for some reason (usually due to temporary network outages or sudden spikes in load immediately after mount), the adaptive timeout value is too short and clients time out their RPCs, you can increase the <code>at_min</code> value to compensate for this.</p>
	<p>Introduced in Lustre 2.16</p> <p>Since Lustre 2.16 it is preferred to set <code>at_min</code> as a per-target tunable using the <code>*.fsname*.at_min</code> parameter instead of the global <code>at_min</code> parameter. This avoids issues if a single client mounts two separate filesystems with different <code>at_min</code> tunable settings.</p>
<code>at_max</code>	<p>Maximum adaptive timeout (in seconds). The <code>at_max</code> parameter is an upper-limit on the service time estimate. If <code>at_max</code> is reached, an RPC request times out.</p> <p>Setting <code>at_max</code> to 0 causes adaptive timeouts to be disabled and a fixed timeout method to be used instead (see Section 39.5.2, “Setting Static Timeouts”)</p>
	<p>Introduced in Lustre 2.16</p> <p>Since Lustre 2.16 it is preferred to set <code>at_max</code> as a per-target tunable using the <code>*.fsname*.at_max</code> parameter instead of the global <code>at_max</code> parameter. This avoids issues if a single client mounts two separate filesystems with different <code>at_max</code> settings.</p>

Parameter	Description
	<p>Note</p> <p>If slow hardware causes the service estimate to increase beyond the default <code>at_max</code> value, increase <code>at_max</code> to the maximum time you are willing to wait for an RPC completion.</p>
<p><code>at_history</code></p>	<p>Time period (in seconds) within which adaptive timeouts remember the slowest event that occurred. The default is 600.</p> <p>Introduced in Lustre 2.16</p> <p>Since Lustre 2.16 it is preferred to set <code>at_history</code> as a per-target tunable using the <code>*.fsname*.at_history</code> parameter instead of the global <code>at_history</code> parameter. This avoids issues if a single client mounts two filesystems with different <code>at_history</code> values.</p>
<p><code>at_early_margin</code></p>	<p>Amount of time before the Lustre server sends an early reply (in seconds). Default is 5.</p>
<p><code>at_extra</code></p>	<p>Incremental amount of time that a server requests with each early reply (in seconds). The server does not know how much time the RPC will take, so it asks for a fixed value. The default is 30, which provides a balance between sending too many early replies for the same RPC and overestimating the actual completion time.</p> <p>When a server finds a queued request about to time out and needs to send an early reply out, the server adds the <code>at_extra</code> value. If the time expires, the Lustre server drops the request, and the client enters recovery status and reconnects to restore the connection to normal status.</p> <p>If you see multiple early replies for the same RPC asking for 30-second increases, change <code>at_extra</code> to a larger number to cut down on early replies sent and, therefore, network load.</p>
<p><code>ldlm_enqueue_min</code></p>	<p>Minimum lock enqueue time (in seconds). The default is 100. The it takes to enqueue a lock, shown as the <code>ldlm_enqueue</code> operation in the stats files, is the maximum of the measured enqueue estimate (influenced by <code>at_min</code> and <code>at_max</code> parameters), multiplied by a weighting factor and the value of <code>ldlm_enqueue_min</code>.</p> <p>Lustre Distributed Lock Manager (LDLM) lock enqueues have a dedicated minimum <code>ldlm_enqueue_min</code>. Lock enqueue timeouts increase as the measured enqueue times increase (similar to adaptive timeouts).</p> <p>Introduced in Lustre 2.16</p> <p>Since Lustre 2.16 it is preferred to set <code>ldlm_enqueue_min</code> as a per-target tunable with <code>*.fsname*.ldlm_enqueue_min</code> instead of the global <code>ldlm_enqueue_min</code> parameter. This avoids issues if a client mounts multiple filesystems with different <code>ldlm_enqueue_min</code> tunable settings.</p>

39.5.1.1. Interpreting Adaptive Timeout Information

Adaptive timeout information can be obtained via `lctl get_param {osc,mdc}.*.timeouts` files on each client and `lctl get_param {ost,mds}.*.*.timeouts` on each server. To read information from a `timeouts` file, enter a command similar to:

```
# lctl get_param -n ost.*.ost_io.timeouts
service : cur 33  worst 34 (at 1193427052, 1600s ago) 1 1 33 2
```

In this example, the `ost_io` service on this node is currently reporting an estimated RPC service time of 33 seconds. The worst RPC service time was 34 seconds, which occurred 26 minutes ago.

The output also provides a history of service times. Four "bins" of adaptive timeout history are shown, with the maximum RPC time in each bin reported. In both the 0-150s bin and the 150-300s bin, the maximum RPC time was 1. The 300-450s bin shows the worst (maximum) RPC time at 33 seconds, and the 450-600s bin shows a maximum of RPC time of 2 seconds. The estimated service time is the maximum value in the four bins (33 seconds in this example).

Service times (as reported by the servers) are also tracked in the client OBDs, as shown in this example:

```
# lctl get_param osc.*.timeouts
last reply : 1193428639, 0d0h00m00s ago
network     : cur  1 worst  2 (at 1193427053, 0d0h26m26s ago)  1  1  1  1
portal 6    : cur 33 worst 34 (at 1193427052, 0d0h26m27s ago) 33 33 33  2
portal 28   : cur  1 worst  1 (at 1193426141, 0d0h41m38s ago)  1  1  1  1
portal 7    : cur  1 worst  1 (at 1193426141, 0d0h41m38s ago)  1  0  1  1
portal 17   : cur  1 worst  1 (at 1193426177, 0d0h41m02s ago)  1  0  0  1
```

In this example, portal 6, the `ost_io` service portal, shows the history of service estimates reported by the portal.

Server statistic files also show the range of estimates including min, max, sum, and sum-squared. For example:

```
# lctl get_param mdt.*.mdt.stats
...
req_timeout           6 samples [sec] 1 10 15 105
...
```

39.5.2. Setting Static Timeouts

The Lustre software provides two sets of static (fixed) timeouts, LND timeouts and Lustre timeouts, which are used when adaptive timeouts are not enabled.

- **LND timeouts** - LND timeouts ensure that point-to-point communications across a network complete in a finite time in the presence of failures, such as packages lost or broken connections. LND timeout parameters are set for each individual LND.

LND timeouts are logged with the `S_LND` flag set. They are not printed as console messages, so check the Lustre log for `D_NETERROR` messages or enable printing of `D_NETERROR` messages to the console using:

```
lctl set_param printk=+neterror
```

Congested routers can be a source of spurious LND timeouts. To avoid this situation, increase the number of LNet router buffers to reduce back-pressure and/or increase LND timeouts on all nodes on

all connected networks. Also consider increasing the total number of LNet router nodes in the system so that the aggregate router bandwidth matches the aggregate server bandwidth.

- **Lustre timeouts** - Lustre timeouts ensure that Lustre RPCs complete in a finite time in the presence of failures when adaptive timeouts are not enabled. Adaptive timeouts are enabled by default. To disable adaptive timeouts at run time, set `at_max` to 0 by running on the MGS:

```
# lctl conf_param fsname.sys.at_max=0
```

Note

Changing the state of adaptive timeouts at runtime may cause transient client timeouts, recovery, and reconnection.

Lustre timeouts are always printed as console messages.

If Lustre timeouts are not accompanied by LND timeouts, increase the Lustre timeout on both servers and clients. Lustre timeouts are set across the whole filesystem using a command such as the following:

```
mgs# lctl set_param -P timeout=30
```

Timeout parameters are described in the table below.

Parameter	Description
<code>timeout</code>	The time that a client waits for a server to complete an RPC (default 100s). Servers wait half this time for a normal client RPC to complete and a quarter of this time for a single bulk request (read or write of up to 4 MB) to complete. The client pings recoverable targets (MDS and OSTs) at one quarter of the timeout, and the server waits one and a half times the timeout before evicting a client for being "stale." Lustre client sends periodic 'ping' messages to servers with which it has had no communication for the specified period of time. Any network activity between a client and a server in the file system also serves as a ping.
<code>ldlm_timeout</code>	The time that a server waits for a client to reply to an initial AST (lock cancellation request). The default is 20s for an OST and 6s for an MDS. If the client replies to the AST, the server will give it a normal timeout (half the client timeout) to flush any dirty data and release the lock.
<code>fail_loc</code>	An internal debugging failure hook. The default value of 0 means that no failure will be triggered or injected.
<code>dump_on_timeout</code>	Triggers a dump of the Lustre debug log when a timeout occurs. The default value of 0 (zero) means a dump of the Lustre debug log will not be triggered.
<code>dump_on_eviction</code>	Triggers a dump of the Lustre debug log when an eviction occurs. The default value of 0 (zero) means a dump of the Lustre debug log will not be triggered.

39.6. Monitoring LNet

LNet information is located via `lctl get_param` in these parameters:

- `peers` - Shows all NIDs known to this node and provides information on the queue state.

Example:

```
# lctl get_param peers
nid          refs  state  max  rtr  min  tx   min  queue
0@lo         1    ~rtr   0    0    0    0    0    0
192.168.10.35@tcp 1    ~rtr   8    8    8    8    6    0
192.168.10.36@tcp 1    ~rtr   8    8    8    8    6    0
192.168.10.37@tcp 1    ~rtr   8    8    8    8    6    0
```

The fields are explained in the table below:

Field	Description
<code>refs</code>	A reference count.
<code>state</code>	If the node is a router, indicates the state of the router. Possible values are: <ul style="list-style-type: none"> • NA - Indicates the node is not a router. • up/down- Indicates if the node (router) is up or down.
<code>max</code>	Maximum number of concurrent sends from this peer.
<code>rtr</code>	Number of available routing buffer credits.
<code>min</code>	Minimum number of routing buffer credits seen.
<code>tx</code>	Number of available send credits.
<code>min</code>	Minimum number of send credits seen.
<code>queue</code>	Total bytes in active/queued sends.

Credits are initialized to allow a certain number of operations (in the example above the table, eight as shown in the `max` column. LNet keeps track of the minimum number of credits ever seen over time showing the peak congestion that has occurred during the time monitored. Fewer available credits indicates a more congested resource.

The number of credits currently available is shown in the `tx` column. The maximum number of send credits is shown in the `max` column and never changes. The number of currently active transmits can be derived by $(\text{max} - \text{tx})$, as long as `tx` is greater than or equal to 0. Once `tx` is less than 0, it indicates the number of transmits on that peer which have been queued for lack of credits.

The number of router buffer credits available for consumption by a peer is shown in `rtr` column. The number of routing credits can be configured separately at the LND level or at the LNet level by using the `peer_buffer_credits` module parameter for the appropriate module. If the routing credits is not set explicitly, it'll default to the maximum transmit credits defined by `peer_credits` module parameter. Whenever a gateway routes a message from a peer, it decrements the number of available routing credits for that peer. If that value goes to zero, then messages will be queued. Negative values show the number of queued message waiting to be routed. The number of messages which are currently being routed from a peer can be derived by $(\text{max_rtr_credits} - \text{rtr})$.

LNet also limits concurrent sends and number of router buffers allocated to a single peer so that no peer can occupy all resources.

- `nis` - Shows current queue health on the node.

Example:

```
# lctl get_param nis
nid                refs   peer   max   tx    min
0@lo                3     0     0     0     0
192.168.10.34@tcp  4     8    256  256  252
```

The fields are explained in the table below.

Field	Description
<code>nid</code>	Network interface.
<code>refs</code>	Internal reference counter.
<code>peer</code>	Number of peer-to-peer send credits on this NID. Credits are used to size buffer pools.
<code>max</code>	Total number of send credits on this NID.
<code>tx</code>	Current number of send credits available on this NID.
<code>min</code>	Lowest number of send credits available on this NID.
<code>queue</code>	Total bytes in active/queued sends.

Analysis:

Subtracting `max` from `tx` (`max - tx`) yields the number of sends currently active. A large or increasing number of active sends may indicate a problem.

39.7. Allocating Free Space on OSTs

Free space is allocated using either a round-robin or a weighted algorithm. The allocation method is determined by the maximum amount of free-space imbalance between the OSTs. When free space is relatively balanced across OSTs, the faster round-robin allocator is used, which maximizes network balancing. The weighted allocator is used when any two OSTs are out of balance by more than a specified threshold.

Free space distribution can be tuned using these two tunable parameters:

- `lod.*.qos_threshold_rr` - The threshold at which the allocation method switches from round-robin to weighted is set in this file. The default is to switch to the weighted algorithm when any two OSTs are out of balance by more than 17 percent.
- `lod.*.qos_prio_free` - The weighting priority used by the weighted allocator can be adjusted in this file. Increasing the value of `qos_prio_free` puts more weighting on the amount of free space available on each OST and less on how stripes are distributed across OSTs. The default value is 91 percent weighting for free space rebalancing and 9 percent for OST balancing. When the free space priority is set to 100, weighting is based entirely on free space and location is no longer used by the striping algorithm.

Introduced in Lustre 2.9

`osp.*.reserved_mb_low` - The low watermark used to stop object allocation if available space is less than this. The default is 0.1% of total OST size.

Introduced in Lustre 2.9

`osp.*.reserved_mb_high` - The high watermark used to start object allocation if available space is more than this. The default is 0.2% of total OST size.

For more information about monitoring and managing free space, see Section 19.8, “Managing Free Space”.

39.8. Configuring Locking

The `lru_size` parameter is used to control the number of client-side locks in the LRU cached locks queue. LRU size is normally dynamic, based on load to optimize the number of locks cached on nodes that have different workloads (e.g., login/build nodes vs. compute nodes vs. backup nodes).

The total number of locks available is a function of the server RAM. The default limit is 50 locks/1 MB of RAM. If memory pressure is too high, the LRU size is shrunk. The number of locks on the server is limited to $num_osts_per_oss * num_clients * lru_size$ as follows:

- To enable automatic LRU sizing, set the `lru_size` parameter to 0. In this case, the `lru_size` parameter shows the current number of locks being used on the client. Dynamic LRU resizing is enabled by default.
- To specify a maximum number of locks, set the `lru_size` parameter to a value other than zero. A good default value for compute nodes is around $100 * num_cpus$. It is recommended that you only set `lru_size` to be significantly larger on a few login nodes where multiple users access the file system interactively.

To clear the LRU on a single client, and, as a result, flush client cache without changing the `lru_size` value, run:

```
# lctl set_param ldln.namespaces.osc_name/mdc_name.lru_size=clear
```

If the LRU size is set lower than the number of existing locks, *unused* locks are canceled immediately. Use `clear` to cancel all locks without changing the value.

Note

The `lru_size` parameter can only be set temporarily using `lctl set_param`, it cannot be set permanently.

To disable dynamic LRU resizing on the clients, run for example:

```
# lctl set_param ldln.namespaces.*osc*.lru_size=5000
```

To determine the number of locks being granted with dynamic LRU resizing, run:

```
$ lctl get_param ldln.namespaces.*.pool.limit
```

The `lru_max_age` parameter is used to control the age of client-side locks in the LRU cached locks queue. This limits how long unused locks are cached on the client, and avoids idle clients from holding locks for an excessive time, which reduces memory usage on both the client and server, as well as reducing work during server recovery.

The `lru_max_age` is printed in milliseconds.

Introduced in Lustre 2.11

Since Lustre 2.11, in addition to setting the maximum lock age in milliseconds, it can also be set using a suffix of s or ms to indicate seconds or milliseconds, respectively. For example to set the client's maximum lock age to 15 minutes (900s) run:

```
# lctl set_param ldlm.namespaces.*MDT*.lru_max_age=900s
# lctl get_param ldlm.namespaces.*MDT*.lru_max_age
ldlm.namespaces.myth-MDT0000-mdc-ffff8804296c2800.lru_max_age=900000
```

39.9. Setting MDS and OSS Thread Counts

MDS and OSS thread counts tunable can be used to set the minimum and maximum thread counts or get the current number of running threads for the services listed in the table below.

Service	Description
mds.MDS.mdt	Main metadata operations service
mds.MDS.mdt_readpage	Metadata readdir service
mds.MDS.mdt_setattr	Metadata setattr/close operations service
ost.OSS.ost	Main data operations service
ost.OSS.ost_io	Bulk data I/O services
ost.OSS.ost_create	OST object pre-creation service
ldlm.services.ldlm_cancel	DLM lock cancel service
ldlm.services.ldlm_cbd	DLM lock grant service

For each service, tunable parameters as shown below are available.

- To temporarily set these tunables, run:

```
# lctl set_param service.threads_min/max/started=num
```

- To permanently set this tunable, run the following command on the MGS:

```
mgs# lctl set_param -P service.threads_min/max/started
```

Introduced in Lustre 2.5

For Lustre 2.5 or earlier, run:

```
mgs# lctl conf_param obdname/fsname.obdtype.threads_min/max/started
```

The following examples show how to set thread counts and get the number of running threads for the service `ost_io` using the tunable `service.threads_min/max/started`.

- To get the number of running threads, run:

```
# lctl get_param ost.OSS.ost_io.threads_started
ost.OSS.ost_io.threads_started=128
```

- To set the number of threads to the maximum value (512), run:

```
# lctl get_param ost.OSS.ost_io.threads_max
ost.OSS.ost_io.threads_max=512
```

- To set the maximum thread count to 256 instead of 512 (to avoid overloading the storage or for an array with requests), run:

```
# lctl set_param ost.OSS.ost_io.threads_max=256
ost.OSS.ost_io.threads_max=256
```

- To set the maximum thread count to 256 instead of 512 permanently, run:

```
# lctl conf_param testfs.ost.ost_io.threads_max=256
```

Introduced in Lustre 2.5

For version 2.5 or later, run:

```
# lctl set_param -P ost.OSS.ost_io.threads_max=256
ost.OSS.ost_io.threads_max=256
```

- To check if the `threads_max` setting is active, run:

```
# lctl get_param ost.OSS.ost_io.threads_max
ost.OSS.ost_io.threads_max=256
```

Note

If the number of service threads is changed while the file system is running, the change may not take effect until the file system is stopped and rest. If the number of service threads in use exceeds the new `threads_max` value setting, service threads that are already running will not be stopped.

See also Chapter 34, *Tuning a Lustre File System*

39.10. Enabling and Interpreting Debugging Logs

By default, a detailed log of all operations is generated to aid in debugging. Flags that control debugging are found via `lctl get_param debug`.

The overhead of debugging can affect the performance of Lustre file system. Therefore, to minimize the impact on performance, the debug level can be lowered, which affects the amount of debugging information kept in the internal log buffer but does not alter the amount of information to goes into `syslog`. You can raise the debug level when you need to collect logs to debug problems.

The debugging mask can be set using "symbolic names". The symbolic format is shown in the examples below.

- To verify the debug level used, examine the parameter that controls debugging by running:

```
# lctl get_param debug
```

```
debug=
ioctl neterror warning error emerg ha config console
```

- To turn off debugging except for network error debugging, run the following command on all nodes concerned:

```
# sysctl -w lnet.debug="neterror"
debug=neterror
```

- To turn off debugging completely (except for the minimum error reporting to the console), run the following command on all nodes concerned:

```
# lctl set_param debug=0
debug=0
```

- To set an appropriate debug level for a production environment, run:

```
# lctl set_param debug="warning dlmtrace error emerg ha rpctrace vfstrace"
debug=warning dlmtrace error emerg ha rpctrace vfstrace
```

The flags shown in this example collect enough high-level information to aid debugging, but they do not cause any serious performance impact.

- To add new flags to flags that have already been set, precede each one with a "+":

```
# lctl set_param debug="+neterror +ha"
debug="+neterror +ha"
# lctl get_param debug
debug=neterror warning error emerg ha console
```

- To remove individual flags, precede them with a "-":

```
# lctl set_param debug="-ha"
debug=-ha
# lctl get_param debug
debug=neterror warning error emerg console
```

Debugging parameters include:

- `subsystem_debug` - Controls the debug logs for subsystems.
- `debug_path` - Indicates the location where the debug log is dumped when triggered automatically or manually. The default path is `/tmp/lustre-log`.

These parameters can also be set using:

```
sysctl -w lnet.debug={value}
```

Additional useful parameters:

- `panic_on_lbug` - Causes "panic" to be called when the Lustre software detects an internal problem (an LBUG log entry); panic crashes the node. This is particularly useful when a kernel crash dump utility is configured. The crash dump is triggered when the internal inconsistency is detected by the Lustre software.
- `upcall` - Allows you to specify the path to the binary which will be invoked when an LBUG log entry is encountered. This binary is called with four parameters:

- The string "LBUG".
- The file where the LBUG occurred.
- The function name.
- The line number in the file

39.10.1. Interpreting OST Statistics

Note

See also Section 12.4, “CollectL” (collectl).

OST stats files can be used to provide statistics showing activity for each OST. For example:

```
# lctl get_param osc.testfs-OST0000-osc.stats
snapshot_time          1189732762.835363
ost_create              1
ost_get_info            1
ost_connect             1
ost_set_info            1
obd_ping                212
```

Use the llstat utility to monitor statistics over time.

To clear the statistics, use the `-c` option to llstat. To specify how frequently the statistics should be reported (in seconds), use the `-i` option. In the example below, the `-c` option clears the statistics and `-i10` option reports statistics every 10 seconds:

```
$ llstat -c -i10 ost_io

/usr/bin/llstat: STATS on 06/06/07
      /proc/fs/lustre/ost/OSS/ost_io/ stats on 192.168.16.35@tcp
snapshot_time          1181074093.276072

/proc/fs/lustre/ost/OSS/ost_io/stats @ 1181074103.284895
Name           Cur.  Cur. #
              Count Rate Events Unit  last  min  avg  max  stddev
req_waittime   8    0    8   [usec] 2078  34  259.75  868  317.49
req_qdepth     8    0    8   [reqs]  1    0    0.12    1    0.35
req_active     8    0    8   [reqs] 11    1    1.38    2    0.52
reqbuf_avail   8    0    8   [bufs] 511   63   63.88   64    0.35
ost_write      8    0    8   [bytes] 169767 72914 212209.62 387579 91874.29

/proc/fs/lustre/ost/OSS/ost_io/stats @ 1181074113.290180
Name           Cur.  Cur. #
              Count Rate Events Unit  last  min  avg  max  stddev
req_waittime   31   3    39   [usec] 30011  34  822.79 12245 2047.71
req_qdepth     31   3    39   [reqs]  0    0    0.03    1    0.16
req_active     31   3    39   [reqs] 58    1    1.77    3    0.74
reqbuf_avail   31   3    39   [bufs] 1977   63   63.79   64    0.41
ost_write      30   3    38   [bytes] 1028467 15019 315325.16 910694 197776.51
```

```
/proc/fs/lustre/ost/OSS/ost_io/stats @ 1181074123.325560
```

```
Name          Cur.  Cur. #
                Count Rate Events Unit  last   min   avg     max   stddev
req_waittime  21   2    60   [usec] 14970  34   784.32  12245 1878.66
req_qdepth    21   2    60   [reqs]  0     0    0.02   1     0.13
req_active    21   2    60   [reqs]  33    1    1.70   3     0.70
reqbuf_avail  21   2    60   [bufs] 1341   63   63.82  64    0.39
ost_write     21   2    59   [bytes] 7648424 15019 332725.08 910694 180397.87
```

The columns in this example are described in the table below.

Parameter	Description
Name	Name of the service event. See the tables below for descriptions of service events that are tracked.
Cur. Count	Number of events of each type sent in the last interval.
Cur. Rate	Number of events per second in the last interval.
# Events	Total number of such events since the events have been cleared.
Unit	Unit of measurement for that statistic (microseconds, requests, buffers).
last	Average rate of these events (in units/event) for the last interval during which they arrived. For instance, in the above mentioned case of <code>ost_destroy</code> it took an average of 736 microseconds per destroy for the 400 object destroys in the previous 10 seconds.
min	Minimum rate (in units/events) since the service started.
avg	Average rate.
max	Maximum rate.
stddev	Standard deviation (not measured in some cases)

Events common to all services are shown in the table below.

Parameter	Description
<code>req_waittime</code>	Amount of time a request waited in the queue before being handled by an available server thread.
<code>req_qdepth</code>	Number of requests waiting to be handled in the queue for this service.
<code>req_active</code>	Number of requests currently being handled.
<code>reqbuf_avail</code>	Number of unsolicited lnet request buffers for this service.

Some service-specific events of interest are described in the table below.

Parameter	Description
<code>ldlm_enqueue</code>	Time it takes to enqueue a lock (this includes file open on the MDS)

Parameter	Description
mds_reint	Time it takes to process an MDS modification record (includes create, mkdir, unlink, rename and setattr)

39.10.2. Interpreting MDT Statistics

Note

See also Section 12.4, “CollectL” (collectl).

MDT stats files can be used to track MDT statistics for the MDS. The example below shows sample output from an MDT stats file.

```
# lctl get_param mds.*-MDT0000.stats
snapshot_time          1244832003.676892 secs.usecs
open                   2 samples [reqs]
close                  1 samples [reqs]
getxattr               3 samples [reqs]
process_config         1 samples [reqs]
connect                2 samples [reqs]
disconnect             2 samples [reqs]
statfs                 3 samples [reqs]
setattr               1 samples [reqs]
getattr               3 samples [reqs]
llog_init              6 samples [reqs]
notify                 16 samples [reqs]
```

Chapter 40. User Utilities

This chapter describes user utilities.

40.1. lfs

The `lfs` utility can be used for user configuration routines and monitoring.

40.1.1. Synopsis

```
lfs
lfs changelog [--follow] mdt_name [startrec [endrec]]
lfs changelog_clear mdt_name id endrec
lfs check mds/osts/servers
lfs data_version [-nrw] filename
lfs df [-i] [-h] [--pool]-p fsname[.pool] [path] [--lazy]
lfs find [[] --atime|-A [+ ]N] [[] --mtime|-M [+ ]N]
    [[] --ctime|-C [+ ]N] [--maxdepth|-D N] [--name|-n pattern]
    [--print|-p] [--print0|-P] [[] --obd|-O ost_name[,ost_name...]]
    [[] --size|-S [+ ]N[kMGTPe]] --type |-t {bcdflpsD}
    [[] --gid|-g|--group|-G gname/gid]
    [[] --uid|-u|--user|-U uname/uid]
    dirname/filename
lfs getname [-h]|[path...]
lfs getstripe [--obd|-O ost_name] [--quiet|-q] [--verbose|-v]
    [--stripe-count|-c] [--stripe-index|-i]
    [--stripe-size|-s] [--pool|-p] [--directory|-d]
    [--mdt-index|-M] [--recursive|-r] [--raw|-R]
    [--layout|-L]
    dirname/filename ...
lfs setstripe [--size|-s stripe_size] [--stripe-count|-c stripe_count]
    [--overstripe-count|-C stripe_count]
    [--stripe-index|-i start_ost_index]
    [--ost-list|-o ost_indicies]
    [--pool|-p pool]
    dirname/filename
lfs setstripe -d dir
lfs osts [path]
lfs pool_list filesystem[.pool]| pathname
lfs quota [-q] [-v] [-h] [-o obd_uuid|-I ost_idx|-i mdt_idx]
    [-u username/uid/-g group/gid|-p projid] /mount_point
lfs quota -t -u|-g|-p /mount_point
lfs setquota {-u|--user|-g|--group|-p|--project} uname/uid/gname/gid/projid
    [--block-softlimit block_softlimit]
    [--block-hardlimit block_hardlimit]
    [--inode-softlimit inode_softlimit]
    [--inode-hardlimit inode_hardlimit]
    /mount_point
lfs setquota -u|--user|-g|--group|-p|--project uname/uid/gname/gid/projid
    [-b block_softlimit] [-B block_hardlimit]
    [-i inode-softlimit] [-I inode_hardlimit]
```



```

                /mount_point
lfs setquota -t -u|-g|-p [--block-grace block_grace]
                [--inode-grace inode_grace]
                /mount_point
lfs setquota -t -u|-g|-p [-b block_grace] [-i inode_grace]
                /mount_point
lfs help

```

Note

In the above example, the `/mount_point` parameter refers to the mount point of the Lustre file system.

Note

The old `lfs quota` output was very detailed and contained cluster-wide quota statistics (including cluster-wide limits for a user/group and cluster-wide usage for a user/group), as well as statistics for each MDS/OST. Now, `lfs quota` has been updated to provide only cluster-wide statistics, by default. To obtain the full report of cluster-wide limits, usage and statistics, use the `-v` option with `lfs quota`.

Introduced in Lustre 2.8

The `quotacheck`, `quotaon` and `quotaoff` sub-commands were deprecated in the Lustre 2.4 release, and removed completely in the Lustre 2.8 release. See Section 25.2, “Enabling Disk Quotas” for details on configuring and checking quotas.

40.1.2. Description

The `lfs` utility is used to create a new file with a specific striping pattern, determine the default striping pattern, gather the extended attributes (object numbers and location) for a specific file, find files with specific attributes, list OST information or set quota limits. It can be invoked interactively without any arguments or in a non-interactive mode with one of the supported arguments.

40.1.3. Options

The various `lfs` options are listed and described below. For a complete list of available options, type `help` at the `lfs` prompt.

Option	Description
<code>changelog</code>	Shows the metadata changes on an MDT. Start and end points are optional. The <code>--follow</code> option blocks on new changes; this option is only valid when run directly on the MDT node.
<code>changelog_clear</code>	Indicates that changelog records previous to <code>endrec</code> are no longer of interest to a particular consumer <code>id</code> , potentially allowing the MDT to free up disk space. An <code>endrec</code> of 0 indicates the current last record. Changelog consumers must be registered on the MDT node using <code>lctl</code> .
<code>check</code>	Displays the status of MDS or OSTs (as specified in the command) or all servers (MDS and OSTs).

Option	Description
<code>data_version [-nrw] filename</code>	<p>Displays the current version of file data. If <code>-n</code> is specified, the data version is read without taking a lock. As a consequence, the data version could be outdated if there are dirty caches on filesystem clients, but this option will not force data flushes and has less of an impact on the filesystem. If <code>-r</code> is specified, the data version is read after dirty pages on clients are flushed. If <code>-w</code> is specified, the data version is read after all caching pages on clients are flushed.</p> <p>Even with <code>-r</code> or <code>-w</code>, race conditions are possible and the data version should be checked before and after an operation to be confident the data did not change during it.</p> <p>The data version is the sum of the last committed transaction numbers of all data objects of a file. It is used by HSM policy engines for verifying that file data has not been changed during an archive operation or before a release operation, and by OST migration, primarily for verifying that file data has not been changed during a data copy, when done in non-blocking mode.</p>
<code>df [-i] [-h] [--pool -p fsname[.pool] [path] [--lazy]</code>	<p>Use <code>-i</code> to report file system disk space usage or inode usage of each MDT or OST or, if a pool is specified with the <code>-p</code> option, a subset of OSTs.</p> <p>By default, the usage of all mounted Lustre file systems is reported. If the <code>path</code> option is included, only the usage for the specified file system is reported. If the <code>-h</code> option is included, the output is printed in human-readable format, using SI base-2 suffixes for Mega-, Giga-, Tera-, Peta-, or Exabytes.</p> <p>If the <code>--lazy</code> option is specified, any OST that is currently disconnected from the client will be skipped. Using the <code>--lazy</code> option prevents the <code>df</code> output from being blocked when an OST is offline. Only the space on the OSTs that can currently be accessed are returned. The <code>llite.*.lazystatfs</code> tunable can be enabled to make this the default behaviour for all <code>statfs()</code> operations.</p>
<code>find</code>	<p>Searches the directory tree rooted at the given directory/filename for files that match the given parameters.</p> <p>Using <code>!</code> before an option negates its meaning (files NOT matching the parameter). Using <code>+</code> before a numeric value means files with the parameter OR</p>

Option	Description
	MORE. Using - before a numeric value means files with the parameter OR LESS.
--atime	<p>File was last accessed N*24 hours ago. (There is no guarantee that atime is kept coherent across the cluster.)</p> <p>OSTs by default only hold a transient atime that is updated when clients do read requests. Permanent atime is written to the MDT when the file is closed. However, on-disk atime is only updated if it is more than 60 seconds old (mdd.*.atime_diff).</p> <p>Introduced in Lustre 2.13</p> <p>In Lustre 2.14, it is possible to set the OSTs to persistently store atime with each object, in order to get more accurate persistent atime updates for files that are open for a long time via the similarly-named obdfilter.*.atime_diff parameter.</p> <p>The client considers the latest atime from all OSTs and MDTs. If a setattr is set by user, then it is updated on both the MDT and OST, allowing the atime to go backward.</p>
--ctime	File status was last changed N*24 hours ago.
--mtime	File data was last modified N*24 hours ago.
--obd	File has an object on a specific OST(s).
--size	File has a size in bytes, or kilo-, Mega-, Giga-, Tera-, Peta- or Exabytes if a suffix is given.
--type	File has the type - block, character, directory, pipe, file, symlink, socket or door (used in Solaris operating system).
--uid	File has a specific numeric user ID.
--user	File owned by a specific user (numeric user ID allowed).
--gid	File has a specific group ID.
--group	File belongs to a specific group (numeric group ID allowed).
- -maxdepth	Limits find to descend at most N levels of the directory tree.
--print/ --print0	Prints the full filename, followed by a new line or NULL character correspondingly.
osts [path]	Lists all OSTs for the file system. If a path located on a mounted Lustre file system is specified, then only OSTs belonging to this file system are displayed.

Option	Description
getname [path...]	List each Lustre file system instance associated with each Lustre mount point. If no path is specified, all Lustre mount points are interrogated. If a list of paths is provided, the instance of each path is provided. If the path is not a Lustre instance 'No such device' is returned.
getstripe	<p>Lists striping information for a given filename or directory. By default, the stripe count, stripe size and offset are returned.</p> <p>If you only want specific striping information, then the options of <code>--stripe-count</code>, <code>--stripe-size</code>, <code>--stripe-index</code>, <code>--layout</code>, or <code>--pool</code> plus various combinations of these options can be used to retrieve specific information.</p> <p>If the <code>--raw</code> option is specified, the stripe information is printed without substituting the file system default values for unspecified fields. If the striping EA is not set, 0, 0, and -1 will be printed for the stripe count, size, and offset respectively.</p> <p>The <code>--mdt-index</code> prints the index of the MDT for a given directory. See Section 14.9.1, "Removing an MDT from the File System".</p>
	<code>--obd <i>ost_name</i></code> Lists files that have an object on a specific OST.
	<code>--quiet</code> Lists details about the file's object ID information.
	<code>--verbose</code> Prints additional striping information.
	<code>--stripe-count</code> Lists the stripe count (how many OSTs to use).
	<code>--index</code> Lists the index for each OST in the file system.
	<code>--offset</code> Lists the OST index on which file striping starts.
	<code>--pool</code> Lists the pools to which a file belongs.
	<code>--size</code> Lists the stripe size (how much data to write to one OST before moving to the next OST).
	<code>--directory</code> Lists entries about a specified directory instead of its contents (in the same manner as <code>ls -d</code>).
	<code>--recursive</code> Recurses into all sub-directories.
setstripe	Create new files with a specific file layout (stripe pattern) configuration. ^a
	<code>--stripe-count <i>stripe_cnt</i></code> Number of OSTs over which to stripe a file. A <code>stripe_cnt</code> of 0 uses the file system-wide default stripe count (default is 1). A <code>stripe_cnt</code> of -1 stripes over all available OSTs.
	<code>--overstripe-count <i>stripe_cnt</i></code> The same as <code>--stripe-count</code> , but allows overstriping, which will place more than one stripe per OST if <code>stripe_cnt</code> is greater than the number of OSTs. Overstriping is useful for matching the number of

Option	Description
	stripes to the number of processes, or with very fast OSTs, where one stripe per OST is not enough to get full performance.
--size <i>stripe_size</i> ^b	Number of bytes to store on an OST before moving to the next OST. A <i>stripe_size</i> of 0 uses the file system's default stripe size, (default is 1 MB). Can be specified with k (KB), m (MB), or g (GB), respectively.
--stripe-index <i>start_ost_index</i>	The OST index (base 10, starting at 0) on which to start striping for this file. A <i>start_ost_index</i> value of -1 allows the MDS to choose the starting index. This is the default value, and it means that the MDS selects the starting OST as it wants. We strongly recommend selecting this default, as it allows space and load balancing to be done by the MDS as needed. The <i>start_ost_index</i> value has no relevance on whether the MDS will use round-robin or QoS weighted allocation for the remaining stripes in the file.
--ost-index <i>ost_indices</i>	This option is used to specify the exact stripe layout on the the file system. <i>ost_indices</i> is a list of OSTs referenced by their indices and index ranges separated by commas, e.g. <i>1, 2-4, 7</i> .
--pool <i>pool</i>	Name of the pre-defined pool of OSTs (see Section 44.2, “lctl”) that will be used for striping. The <i>stripe_cnt</i> , <i>stripe_size</i> and <i>start_ost</i> values are used as well. The <i>start-ost</i> value must be part of the pool or an error is returned.
setstripe -d	Deletes default striping on the specified directory.
pool_list {filesystem}[.poolname] {pathname}	Lists pools in the file system or pathname, or OSTs in the file system's pool.
quota [-q] [-v] [-o <i>obd_uid</i> -i <i>mdt_idx</i> -I <i>ost_idx</i>] [-u -g -p <i>uname</i> <i>uid</i> / <i>gname</i> <i>gid</i> / <i>projid</i>] / <i>mount_point</i>	Displays disk usage and limits, either for the full file system or for objects on a specific OBD. A user or group name or an <i>usr</i> , <i>group</i> and <i>project ID</i> can be specified. If all user, <i>group</i> <i>project ID</i> are omitted, quotas for the current <i>UID/GID</i> are shown. The <i>-q</i> option disables printing of additional descriptions (including column titles). It fills in blank spaces in the <i>grace</i> column with zeros (when there is no <i>grace</i> period set), to ensure that the number of columns is consistent. The <i>-v</i> option provides more verbose (per- <i>OBD</i> statistics) output.
quota -t -u -g -p / <i>mount_point</i>	Displays block and inode <i>grace</i> times for user (<i>-u</i>) or group (<i>-g</i>) or project (<i>-p</i>) quotas.
setquota { -u -g -p <i>uname</i> / <i>uid</i> / <i>gname</i> / <i>gid</i> / <i>projid</i> } [--block-softlimit <i>block_softlimit</i>] [--block-hardlimit <i>block_hardlimit</i>] [--inode-softlimit	Sets file system quotas for users, groups or one project. Limits can be specified with --{ <i>block</i> <i>inode</i> }-{ <i>softlimit</i> <i>hardlimit</i> } or their short equivalents <i>-b</i> , <i>-B</i> , <i>-i</i> , <i>-I</i> . Users can set 1, 2, 3 or 4 limits. ^c Also, limits can be specified

Option	Description
<code>inode_softlimit</code> <code>inode_hardlimit</code> <code>mount_point</code> <code>[--inode- hardlimit <i>inode_hardlimit</i> / mount_point</code>	with special suffixes, -b, -k, -m, -g, -t, and -p to indicate units of 1, 2 ¹⁰ , 2 ²⁰ , 2 ³⁰ , 2 ⁴⁰ and 2 ⁵⁰ , respectively. By default, the block limits unit is 1 kilobyte (1,024), and block limits are always kilobyte-grained (even if specified in bytes). See Section 40.1.4, “Examples”.
<code>setquota -t -u -g -p [--block- grace <i>block_grace</i>] [--inode- grace <i>inode_grace</i>] /mount_point</code>	Sets the file system quota grace times for users or groups. Grace time is specified in 'XXwXXdXXhXXmXXs' format or as an integer seconds value. See Section 40.1.4, “Examples”.
<code>help</code>	Provides brief help on various <code>lfs</code> arguments.
<code>exit/quit</code>	Quits the interactive <code>lfs</code> session.

^aThe file cannot exist prior to using `setstripe`. A directory must exist prior to using `setstripe`.

^bThe default stripe-size is 0. The default start-ost is -1. Do NOT confuse them! If you set start-ost to 0, all new file creations occur on OST 0 (seldom a good idea).

^cThe old `setquota` interface is supported, but it may be removed in a future Lustre software release.

40.1.4. Examples

Creates a file striped on two OSTs with 128 KB on each stripe.

```
$ lfs setstripe -s 128k -c 2 /mnt/lustre/file1
```

Deletes a default stripe pattern on a given directory. New files use the default striping pattern.

```
$ lfs setstripe -d /mnt/lustre/dir
```

Lists the detailed object allocation of a given file.

```
$ lfs getstripe -v /mnt/lustre/file1
```

List all the mounted Lustre file systems and corresponding Lustre instances.

```
$ lfs getname
```

Efficiently lists all files in a given directory and its subdirectories.

```
$ lfs find /mnt/lustre
```

Recursively lists all regular files in a given directory more than 30 days old.

```
$ lfs find /mnt/lustre -mtime +30 -type f -print
```

Recursively lists all files in a given directory that have objects on OST2-UUID. The `lfs check servers` command checks the status of all servers (MDT and OSTs).

```
$ lfs find --obd OST2-UUID /mnt/lustre/
```

Lists all OSTs in the file system.

```
$ lfs osts
```

Lists space usage per OST and MDT in human-readable format.

```
$ lfs df -h
```

Lists inode usage per OST and MDT.

```
$ lfs df -i
```

List space or inode usage for a specific OST pool.

```
$ lfs df --pool  
filesystem[.  
pool] |  
pathname
```

List quotas of user 'bob'.

```
$ lfs quota -u bob /mnt/lustre
```

List quotas of project ID '1'.

```
$ lfs quota -p 1 /mnt/lustre
```

Show grace times for user quotas on /mnt/lustre.

```
$ lfs quota -t -u /mnt/lustre
```

Sets quotas of user 'bob', with a 1 GB block quota hardlimit and a 2 GB block quota softlimit.

```
$ lfs setquota -u bob --block-softlimit 2000000 --block-hardlimit 1000000  
/mnt/lustre
```

Sets grace times for user quotas: 1000 seconds for block quotas, 1 week and 4 days for inode quotas.

```
$ lfs setquota -t -u --block-grace 1000 --inode-grace 1w4d /mnt/lustre
```

Checks the status of all servers (MDT, OST)

```
$ lfs check servers
```

Creates a file striped on two OSTs from the pool `my_pool`

```
$ lfs setstripe --pool my_pool -c 2 /mnt/lustre/file
```

Lists the pools defined for the mounted Lustre file system /mnt/lustre

```
$ lfs pool_list /mnt/lustre/
```

Lists the OSTs which are members of the pool `my_pool` in file system `my_fs`

```
$ lfs pool_list my_fs.my_pool
```

Finds all directories/files associated with `poolA`.

```
$ lfs find /mnt/lustre --pool poolA
```

Finds all directories/files not associated with a pool.

```
$ lfs find /mnt//lustre --pool ""
```

Finds all directories/files associated with `pool`.

```
$ lfs find /mnt/lustre ! --pool ""
```

Associates a directory with the pool `my_pool`, so all new files and directories are created in the pool.

```
$ lfs setstripe --pool my_pool /mnt/lustre/dir
```

40.1.5. See Also

Section 44.2, “`lctl`”

40.2. `lfs_migrate`

The `lfs_migrate` utility is a simple to migrate file *data* between OSTs.

40.2.1. Synopsis

```
lfs_migrate [lfs_setstripe_options]  
[-h] [-n] [-q] [-R] [-s] [-y] [-0] [file|directory ...]
```

40.2.2. Description

The `lfs_migrate` utility is a tool to assist migration of file data between Lustre OSTs. The utility copies each specified file to a temporary file using supplied `lfs setstripe` options, if any, optionally verifies the file contents have not changed, and then swaps the layout (OST objects) from the temporary file and the original file (for Lustre 2.5 and later), or renames the temporary file to the original filename. This allows the user/administrator to balance space usage between OSTs, or move files off OSTs that are starting to show hardware problems (though are still functional) or will be removed.

Warning

For versions of Lustre before 2.5, `lfs_migrate` was not integrated with the MDS at all. That made it UNSAFE for use on files that were being modified by other applications, since the file was migrated through a copy and rename of the file. With Lustre 2.5 and later, the new file layout is swapped with the existing file layout, which ensures that the user-visible inode number is kept, and open file handles and locks on the file are kept.

Files to be migrated can be specified as command-line arguments. If a directory is specified on the command-line then all files within the directory are migrated. If no files are specified on the command-line, then a list of files is read from the standard input, making `lfs_migrate` suitable for use with `lfs find` to locate files on specific OSTs and/or matching other file attributes, and other tools that generate a list of files on standard output.

Unless otherwise specified through command-line options, the file allocation policies on the MDS dictate where the new files are placed, taking into account whether specific OSTs have been disabled on the MDS via `lctl` (preventing new files from being allocated there), whether some OSTs are overly full (reducing the number of files placed on those OSTs), or if there is a specific default file striping for the parent directory (potentially changing the stripe count, stripe size, OST pool, or OST index of a new file).

Note

The `lfs_migrate` utility can also be used in some cases to reduce file fragmentation. File fragmentation will typically reduce Lustre file system performance. File fragmentation may be observed on an aged file system and will commonly occur if the file was written by many threads. Provided there is sufficient free space (or if it was written when the file system was nearly full) that is less fragmented than the file being copied, re-writing a file with `lfs_migrate` will result in a migrated file with reduced fragmentation. The tool `filefrag` can be used to report file fragmentation. See Section 40.3, “`filefrag`”

Note

As long as a file has extent lengths of tens of megabytes ($read_bandwidth * seek_time$) or more, the read performance for the file will not be significantly impacted by fragmentation, since the read pipeline can be filled by large reads from disk even with an occasional disk seek.

40.2.3. Options

Options supporting `lfs_migrate` are described below.

Option	Description
<code>-c stripecount</code>	Restripe file using the specified stripe count. This option may not be specified at the same time as the <code>-R</code> option.
<code>-h</code>	Display help information.
<code>-l</code>	Migrate files with hard links (skips, by default). Files with multiple hard links are split into multiple separate files by <code>lfs_migrate</code> , so they are skipped, by default, to avoid breaking the hard links.
<code>-n</code>	Only print the names of files to be migrated.
<code>-q</code>	Run quietly (does not print filenames or status).

Option	Description
-R	Restripe file using default directory striping instead of keeping striping. This option may not be specified at the same time as the <code>-c</code> option.
-s	Skip file data comparison after migrate. Default is to compare migrated file against original to verify correctness.
-y	Answer 'y' to usage warning without prompting (for scripts, use with caution).
-0	Expect NUL-terminated filenames on standard input, as generated by <code>lfs find -print0</code> or <code>find -print0</code> . This allows filenames with embedded newlines to be handled correctly.

40.2.4. Examples

Rebalance all files in `/mnt/lustre/dir`:

```
$ lfs_migrate /mnt/lustre/dir
```

Migrate files in `/test` filesystem on `OST0004` larger than 4 GB in size and older than a day old:

```
$ lfs find /test -obd test-OST0004 -size +4G -mtime +1 | lfs_migrate -y
```

40.2.5. See Also

Section 40.1, “`lfs`”

40.3. filefrag

The `e2fsprogs` package contains the `filefrag` tool which reports the extent of file fragmentation.

40.3.1. Synopsis

```
filefrag [ -belsv ] [ files... ]
```

40.3.2. Description

The `filefrag` utility reports the extent of fragmentation in a given file. The `filefrag` utility obtains the extent information from Lustre files using the `FIEMAP ioctl`, which is efficient and fast, even for very large files.

In default mode ¹, `filefrag` prints the number of physically discontinuous extents in the file. In extent or verbose mode, each extent is printed with details such as the blocks allocated on each OST. For a Lustre file system, the extents are printed in device offset order (i.e. all of the extents for one OST first, then the

¹The default mode is faster than the verbose/extent mode since it only counts the number of extents.

next OST, etc.), not file logical offset order. If the file logical offset order was used, the Lustre striping would make the output very verbose and difficult to see if there was file fragmentation or not.

Note

Note that as long as a file has extent lengths of tens of megabytes or more (i.e. $read_bandwidth * seek_time > extent_length$), the read performance for the file will not be significantly impacted by fragmentation, since file readahead can fully utilize the disk bandwidth even with occasional seeks.

In default mode², `filefrag` returns the number of physically discontinuous extents in the file. In extent or verbose mode, each extent is printed with details. For a Lustre file system, the extents are printed in device offset order, not logical offset order.

40.3.3. Options

The options and descriptions for the `filefrag` utility are listed below.

Option	Description
<code>-b</code>	Uses the 1024-byte blocksize for the output. By default, this blocksize is used by the Lustre file system, since OSTs may use different block sizes.
<code>-e</code>	Uses the extent mode when printing the output. This is the default for Lustre files in verbose mode.
<code>-l</code>	Displays extents in LUN offset order. This is the only available mode for Lustre.
<code>-s</code>	Synchronizes any unwritten file data to disk before requesting the mapping.
<code>-v</code>	Prints the file's layout in verbose mode when checking file fragmentation, including the logical to physical mapping for each extent in the file and the OST index.

40.3.4. Examples

Lists default output.

```
$ filefrag /mnt/lustre/foo
/mnt/lustre/foo: 13 extents found
```

Lists verbose output in extent format.

```
$ filefrag -v /mnt/lustre/foo
Filesystem type is: bd00bd0
File size of /mnt/lustre/foo is 1468297786 (1433888 blocks of 1024 bytes)
ext:      device_logical:      physical_offset: length: dev: flags:
  0:      0.. 122879: 2804679680..2804802559: 122880: 0002: network
```

²The default mode is faster than the verbose/extent mode.

```

1: 122880.. 245759: 2804817920..2804940799: 122880: 0002: network
2: 245760.. 278527: 2804948992..2804981759: 32768: 0002: network
3: 278528.. 360447: 2804982784..2805064703: 81920: 0002: network
4: 360448.. 483327: 2805080064..2805202943: 122880: 0002: network
5: 483328.. 606207: 2805211136..2805334015: 122880: 0002: network
6: 606208.. 729087: 2805342208..2805465087: 122880: 0002: network
7: 729088.. 851967: 2805473280..2805596159: 122880: 0002: network
8: 851968.. 974847: 2805604352..2805727231: 122880: 0002: network
9: 974848.. 1097727: 2805735424..2805858303: 122880: 0002: network
10: 1097728.. 1220607: 2805866496..2805989375: 122880: 0002: network
11: 1220608.. 1343487: 2805997568..2806120447: 122880: 0002: network
12: 1343488.. 1433599: 2806128640..2806218751: 90112: 0002: network
/mnt/lustre/foo: 13 extents found

```

40.4. mount

The standard `mount(8)` Linux command is used to mount a Lustre file system. When mounting a Lustre file system, `mount(8)` executes the `/sbin/mount.lustre` command to complete the mount. The `mount` command supports these options specific to a Lustre file system:

Server options	Description
<code>abort_recov</code>	Aborts recovery when starting a target
<code>nosvc</code>	Starts only MGS/MGC servers
<code>nomgs</code>	Start a MDT with a co-located MGS without starting the MGS
<code>exclude</code>	Starts with a dead OST
<code>md_stripe_cache_size</code>	Sets the stripe cache size for server side disk with a striped raid configuration

Client options	Description
<code>flock/noflock/localflock</code>	Enables/disables global flock or local flock support
<code>user_xattr/nouser_xattr</code>	Enables/disables user-extended attributes
<code>user_fid2path/nouser_fid2path</code>	Enables/disables FID to path translation by regular users
<code>retry=</code>	Number of times a client will retry to mount the file system

40.5. Handling Timeouts

Timeouts are the most common cause of hung applications. After a timeout involving an MDS or failover OST, applications attempting to access the disconnected resource wait until the connection gets established.

When a client performs any remote operation, it gives the server a reasonable amount of time to respond. If a server does not reply either due to a down network, hung server, or any other reason, a timeout occurs which requires a recovery.

If a timeout occurs, a message (similar to this one), appears on the console of the client, and in `/var/log/messages`:

```
LustreError: 26597:(client.c:810:ptlrpc_expire_one_request()) @@@ timeout  
req@a2d45200 x5886/t0 o38->mds_svc_UUID@NID_mds_UUID:12 lens 168/64 ref 1 fl  
RPC:/0/0 rc 0
```

Chapter 41. Programming Interfaces

This chapter describes public programming interfaces to that can be used to control various aspects of a Lustre file system from userspace. This chapter includes the following sections:

- Section 41.1, “User/Group Upcall”
- Section 41.1.3, “Data Structures”

Note

Lustre programming interface man pages are found in the `lustre/doc` folder.

41.1. User/Group Upcall

This section describes the supplementary user/group upcall, which allows the MDS to retrieve and verify the supplementary groups to which a particular user is assigned. This avoids the need to pass all the supplementary groups from the client to the MDS with every RPC.

Note

For information about universal UID/GID requirements in a Lustre file system environment, see Section 8.1.2, “Environmental Requirements”.

41.1.1. Synopsis

The MDS uses the utility as specified by `lctl get_param mdt.${FSNAME}-MDT{xxxx}.identity_upcall` to look up the supplied UID in order to retrieve the user's supplementary group membership. The result is temporarily cached in the kernel (for five minutes, by default) to avoid the overhead of calling into userspace repeatedly.

41.1.2. Description

The `identity_upcall` parameter contains the path to an executable that is run to map a numeric UID to a group membership list. This upcall executable opens the `mdt.${FSNAME}-MDT{xxxx}.identity_info` parameter file and writes the related `identity_downcall_data` data structure (see Section 41.1.3, “Data Structures”). The upcall is configured with `lctl set_param mdt.${FSNAME}-MDT{xxxx}.identity_upcall`.

The default identity upcall program installed is `lustre/utils/l_getidentity.c` in the Lustre source distribution.

41.1.2.1. Primary and Secondary Groups

The mechanism for the primary/secondary group is as follows:

- The MDS issues an upcall (set per MDS) to map the numeric UID to the supplementary group(s).
- If there is no upcall or if there is an upcall and it fails, one supplementary group at most will be added as supplied by the client.
- The default upcall `/usr/sbin/l_getidentity` can interact with the user/group database on the MDS to map the UID to the GID and supplementary GID. The user/group database depends on how

authentication is configured on the MDS, such as local `/etc/passwd`, Network Information Service (NIS), Lightweight Directory Access Protocol (LDAP), or SMB Domain services, as configured. If the upcall interface is set to NONE, then upcall is disabled, and the MDS uses only the UID, GID, and one supplementary GID supplied by the client.

- The MDS will wait a limited time for the group upcall program to complete, to avoid MDS threads and clients hanging due to errors accessing a remote service node. The upcall must finish within 30s before the MDS will continue without the supplementary data. The upcall timeout in seconds can be set on the MDS using: `lctl set_param mdt.*.identity_acquire_expire=seconds`
- The default group upcall is set permanently by `mkfs.lustre`. To set a custom upcall for a particular filesystem, use `tunefs.lustre --param` or `lctl set_param -P mdt.FSNAME-MDTxxxx.identity_upcall=path`
- The group downcall data is cached by the kernel to avoid repeated upcalls for the same user slowing down the MDS. This cache is expired from the kernel after 1200s (20 minutes) by default. The cache age in seconds can be set on the MDS using: `lctl set_param mdt.*.identity_expire=seconds`
- To force eviction of cached identity data (e.g. after adding or removing a user from a supplementary group), the cache entry for a specific numeric UID can be flushed on the MDS using: `lctl set_param mdt.*.identity_flush=UID` To flush the cached records for all users from cache, use `-1` for the UID: `lctl set_param mdt.*.identity_flush=-1`

41.1.3. Data Structures

```
struct perm_downcall_data {
    __u64 pdd_nid;
    __u32 pdd_perm;
    __u32 pdd_padding;
};

struct identity_downcall_data{
    __u32      idd_magic;
    :
    :
```

Chapter 42. Setting Lustre Properties in a C Program (llapi)

This chapter describes the `llapi` library of commands used for setting Lustre file properties within a C program running in a cluster environment, such as a data processing or MPI application. The commands described in this chapter are:

- Section 42.1, “`llapi_file_create`”
- Section 42.2, “`llapi_file_get_stripe`”
- Section 42.3, “`llapi_file_open`”
- Section 42.4, “`llapi_quotactl`”
- Section 42.5, “`llapi_path2fid`”

Note

Lustre programming interface man pages are found in the `lustre/doc` folder.

42.1. llapi_file_create

Use `llapi_file_create` to set Lustre properties for a new file.

42.1.1. Synopsis

```
#include <lustre/lustreapi.h>
```

```
int llapi_file_create(char *name, long stripe_size, int stripe_offset, int stripe_
```

42.1.2. Description

The `llapi_file_create()` function sets a file descriptor's Lustre file system striping information. The file descriptor is then accessed with `open()`.

Option	Description
<code>llapi_file_create()</code>	If the file already exists, this parameter returns to 'EEXIST'. If the stripe parameters are invalid, this parameter returns to 'EINVAL'.
<code>stripe_size</code>	This value must be an even multiple of system page size, as shown by <code>getpagesize()</code> . The default Lustre stripe size is 4MB.
<code>stripe_offset</code>	Indicates the starting OST for this file.
<code>stripe_count</code>	Indicates the number of OSTs that this file will be striped across.
<code>stripe_pattern</code>	Indicates the RAID pattern.

Note

Currently, only RAID 0 is supported. To use the system defaults, set these values:
`stripe_size=0, stripe_offset=-1, stripe_count=0, stripe_pattern=0`

42.1.3. Examples

System default size is 4 MB.

```
char *tfile = TESTFILE;
int stripe_size = 65536
```

To start at default, run:

```
int stripe_offset = -1
```

To start at the default, run:

```
int stripe_count = 1
```

To set a single stripe for this example, run:

```
int stripe_pattern = 0
```

Currently, only RAID 0 is supported.

```
int stripe_pattern = 0;
int rc, fd;
rc = llapi_file_create(tfile, stripe_size, stripe_offset, stripe_count, stripe_patte
```

Result code is inverted, you may return with 'EINVAL' or an ioctl error.

```
if (rc) {
    fprintf(stderr, "llapi_file_create failed: %d (%s) 0, rc, strerror(-rc));return -1;
```

`llapi_file_create` closes the file descriptor. You must re-open the descriptor. To do this, run:

```
fd = open(tfile, O_CREAT | O_RDWR | O_LOV_DELAY_CREATE, 0644); if (fd < 0) \ {
    fprintf(stderr, "Can't open %s file: %s0, tfile,
    str-
    error(errno));
    return -1;
}
```

42.2. llapi_file_get_stripe

Use `llapi_file_get_stripe` to get striping information for a file or directory on a Lustre file system.

42.2.1. Synopsis

```
#include <lustre/lustreapi.h>
```

```
int llapi_file_get_stripe(const char *path, void *lum);
```

42.2.2. Description

The `llapi_file_get_stripe()` function returns striping information for a file or directory *path* in *lum* (which should point to a large enough memory region) in one of the following formats:

```
struct lov_user_md_v1 {
    __u32 lmm_magic;
    __u32 lmm_pattern;
    __u64 lmm_object_id;
    __u64 lmm_object_seq;
    __u32 lmm_stripe_size;
    __u16 lmm_stripe_count;
    __u16 lmm_stripe_offset;
    struct lov_user_ost_data_v1 lmm_objects[0];
} __attribute__((packed));
struct lov_user_md_v3 {
    __u32 lmm_magic;
    __u32 lmm_pattern;
    __u64 lmm_object_id;
    __u64 lmm_object_seq;
    __u32 lmm_stripe_size;
    __u16 lmm_stripe_count;
    __u16 lmm_stripe_offset;
    char lmm_pool_name[LOV_MAXPOOLNAME];
    struct lov_user_ost_data_v1 lmm_objects[0];
} __attribute__((packed));
```

Option	Description
<code>lmm_magic</code>	Specifies the format of the returned striping information. <code>LOV_MAGIC_V1</code> is used for <code>lov_user_md_v1</code> . <code>LOV_MAGIC_V3</code> is used for <code>lov_user_md_v3</code> .
<code>lmm_pattern</code>	Holds the striping pattern. Only <code>LOV_PATTERN_RAID0</code> is possible in this Lustre software release.
<code>lmm_object_id</code>	Holds the MDS object ID.
<code>lmm_object_gr</code>	Holds the MDS object group.
<code>lmm_stripe_size</code>	Holds the stripe size in bytes.
<code>lmm_stripe_count</code>	Holds the number of OSTs over which the file is striped.
<code>lmm_stripe_offset</code>	Holds the OST index from which the file starts.
<code>lmm_pool_name</code>	Holds the OST pool name to which the file belongs.
<code>lmm_objects</code>	An array of <code>lmm_stripe_count</code> members containing per OST file information in the following format: <pre>struct lov_user_ost_data_v1 { __u64 l_object_id;</pre>

Option	Description
	<pre> __u64 l_object_seq; __u32 l_ost_gen; __u32 l_ost_idx; } __attribute__((packed)); </pre>
l_object_id	Holds the OST's object ID.
l_object_seq	Holds the OST's object group.
l_ost_gen	Holds the OST's index generation.
l_ost_idx	Holds the OST's index in LOV.

42.2.3. Return Values

llapi_file_get_stripe() returns:

0 On success

!= 0 On failure, errno is set appropriately

42.2.4. Errors

Errors	Description
ENOMEM	Failed to allocate memory
ENAMETOOLONG	Path was too long
ENOENT	Path does not point to a file or directory
ENOTTY	Path does not point to a Lustre file system
EFAULT	Memory region pointed by lum is not properly mapped

42.2.5. Examples

```

#include <stdio.h>
#include <stdlib.h>
#include <errno.h>
#include <lustre/lustreapi.h>

static inline int maxint(int a, int b)
{
    return a > b ? a : b;
}
static void *alloc_lum()
{
    int v1, v3, join;
    v1 = sizeof(struct lov_user_md_v1) +
        LOV_MAX_STRIPE_COUNT * sizeof(struct lov_user_ost_data_v1);
    v3 = sizeof(struct lov_user_md_v3) +
        LOV_MAX_STRIPE_COUNT * sizeof(struct lov_user_ost_data_v1);
    return malloc(maxint(v1, v3));
}

```

```
int main(int argc, char** argv)
{
    struct lov_user_md *lum_file = NULL;
    int rc;
    int lum_size;
    if (argc != 2) {
        fprintf(stderr, "Usage: %s <filename>\n", argv[0]);
        return 1;
    }
    lum_file = alloc_lum();
    if (lum_file == NULL) {
        rc = ENOMEM;
        goto cleanup;
    }
    rc = llapi_file_get_stripe(argv[1], lum_file);
    if (rc) {
        rc = errno;
        goto cleanup;
    }
    /* stripe_size stripe_count */
    printf("%d %d\n",
        lum_file->lmm_stripe_size,
        lum_file->lmm_stripe_count);
cleanup:
    if (lum_file != NULL)
        free(lum_file);
    return rc;
}
```

42.3. llapi_file_open

The `llapi_file_open` command opens (or creates) a file or device on a Lustre file system.

42.3.1. Synopsis

```
#include <lustre/lustreapi.h>
int llapi_file_open(const char *name, int flags, int mode,
    unsigned long long stripe_size, int stripe_offset,
    int stripe_count, int stripe_pattern);
int llapi_file_create(const char *name, unsigned long long stripe_size,
    int stripe_offset, int stripe_count,
    int stripe_pattern);
```

42.3.2. Description

The `llapi_file_create()` call is equivalent to the `llapi_file_open` call with *flags* equal to `O_CREAT|O_WRONLY` and *mode* equal to `0644`, followed by file close.

`llapi_file_open()` opens a file with a given name on a Lustre file system.

Option	Description
flags	Can be a combination of <code>O_RDONLY</code> , <code>O_WRONLY</code> , <code>O_RDWR</code> , <code>O_CREAT</code> , <code>O_EXCL</code> , <code>O_NOCTTY</code> ,

Option	Description
	O_TRUNC, O_APPEND, O_NONBLOCK, O_SYNC, FASYNC, O_DIRECT, O_LARGEFILE, O_DIRECTORY, O_NOFOLLOW, O_NOATIME.
mode	Specifies the permission bits to be used for a new file when O_CREAT is used.
stripe_size	Specifies stripe size (in bytes). Should be multiple of 64 KB, not exceeding 4 GB.
stripe_offset	Specifies an OST index from which the file should start. The default value is -1.
stripe_count	Specifies the number of OSTs to stripe the file across. The default value is -1.
stripe_pattern	Specifies the striping pattern. In this release of the Lustre software, only LOV_PATTERN_RAID0 is available. The default value is 0.

42.3.3. Return Values

llapi_file_open() and llapi_file_create() return:

>=0 On success, for llapi_file_open the return value is a file descriptor

<0 On failure, the absolute value is an error code

42.3.4. Errors

Errors	Description
EINVAL	stripe_size or stripe_offset or stripe_count or stripe_pattern is invalid.
EEXIST	Striping information has already been set and cannot be altered; name already exists.
EALREADY	Striping information has already been set and cannot be altered
ENOTTY	name may not point to a Lustre file system.

42.3.5. Example

```
#include <stdio.h>
#include <lustre/lustreapi.h>

int main(int argc, char *argv[])
{
    int rc;
    if (argc != 2)
        return -1;
    rc = llapi_file_create(argv[1], 1048576, 0, 2, LOV_PATTERN_RAID0);
    if (rc < 0) {
```

```

    fprintf(stderr, "file creation has failed, %s\n",      strerror(-rc));
    return -1;
}
printf("%s with stripe size 1048576, striped across 2 OSTs,"
       " has been created!\n", argv[1]);
return 0;
}

```

42.4. llapi_quotactl

Use llapi_quotactl to manipulate disk quotas on a Lustre file system.

42.4.1. Synopsis

```

#include <lustre/lustreapi.h>
int llapi_quotactl(char " " *mnt, " " struct if_quotactl " " *qctl)

struct if_quotactl {
    __u32                qc_cmd;
    __u32                qc_type;
    __u32                qc_id;
    __u32                qc_stat;
    struct obd_dqinfo    qc_dqinfo;
    struct obd_dqblk     qc_dqblk;
    char                 obd_type[16];
    struct obd_uuid      obd_uuid;
};

struct obd_dqblk {
    __u64 dqb_bhardlimit;
    __u64 dqb_bsoftlimit;
    __u64 dqb_curspace;
    __u64 dqb_ihardlimit;
    __u64 dqb_isoftlimit;
    __u64 dqb_curinodes;
    __u64 dqb_btime;
    __u64 dqb_itime;
    __u32 dqb_valid;
    __u32 padding;
};

struct obd_dqinfo {
    __u64 dqi_bgrace;
    __u64 dqi_igrace;
    __u32 dqi_flags;
    __u32 dqi_valid;
};

struct obd_uuid {
    char uuid[40];
};

```

42.4.2. Description

The llapi_quotactl() command manipulates disk quotas on a Lustre file system mount. qc_cmd indicates a command to be applied to UID qc_id or GID qc_id.

Option	Description
LUSTRE_Q_GETQUOTA	Gets disk quota limits and current usage for user or group <i>qc_id</i> . <i>qc_type</i> is USRQUOTA or GRPQUOTA. <i>uuid</i> may be filled with OBD UUID string to query quota information from a specific node. <i>dqb_valid</i> may be set nonzero to query information only from MDS. If <i>uuid</i> is an empty string and <i>dqb_valid</i> is zero then cluster-wide limits and usage are returned. On return, <i>obd_dqblk</i> contains the requested information (block limits unit is kilobyte). Quotas must be turned on before using this command.
LUSTRE_Q_SETQUOTA	Sets disk quota limits for user or group <i>qc_id</i> . <i>qc_type</i> is USRQUOTA or GRPQUOTA. <i>dqb_valid</i> must be set to QIF_ILIMITS, QIF_BLIMITS or QIF_LLIMITS (both inode limits and block limits) dependent on updating limits. <i>obd_dqblk</i> must be filled with limits values (as set in <i>dqb_valid</i> , block limits unit is kilobyte). Quotas must be turned on before using this command.
LUSTRE_Q_GETINFO	Gets information about quotas. <i>qc_type</i> is either USRQUOTA or GRPQUOTA. On return, <i>dqi_igrace</i> is inode grace time (in seconds), <i>dqi_bgrace</i> is block grace time (in seconds), <i>dqi_flags</i> is not used by the current release of the Lustre software.
LUSTRE_Q_SETINFO	Sets quota information (like grace times). <i>qc_type</i> is either USRQUOTA or GRPQUOTA. <i>dqi_igrace</i> is inode grace time (in seconds), <i>dqi_bgrace</i> is block grace time (in seconds), <i>dqi_flags</i> is not used by the current release of the Lustre software and must be zeroed.

42.4.3. Return Values

llapi_quotactl() returns:

0 On success

-1 On failure and sets error number (errno) to indicate the error

42.4.4. Errors

llapi_quotactl errors are described below.

Errors	Description
EFAULT	<i>qctl</i> is invalid.
ENOSYS	Kernel or Lustre modules have not been compiled with the QUOTA option.
ENOMEM	Insufficient memory to complete operation.
ENOTTY	<i>qc_cmd</i> is invalid.

Errors	Description
ENOENT	<i>uuid</i> does not correspond to OBD or <i>mnt</i> does not exist.
EPERM	The call is privileged and the caller is not the super user.
ESRCH	No disk quota is found for the indicated user. Quotas have not been turned on for this file system.

42.5. llapi_path2fid

Use `llapi_path2fid` to get the FID from the pathname.

42.5.1. Synopsis

```
#include <lustre/lustreapi.h>
```

```
int llapi_path2fid(const char *path, unsigned long long *seq, unsigned long *oid,
```

42.5.2. Description

The `llapi_path2fid` function returns the FID (sequence : object ID : version) for the pathname.

42.5.3. Return Values

`llapi_path2fid` returns:

0 On success

non-zero value On failure

Introduced in Lustre 2.9

42.6. llapi_ladvise

Use `llapi_ladvise` to give IO advice/hints on a Lustre file to the server.

42.6.1. Synopsis

```
#include <lustre/lustreapi.h>
int llapi_ladvise(int fd, unsigned long long flags,
                 int num_advise, struct llapi_lu_ladvise *ladvise);

struct llapi_lu_ladvise {
    __u16 lla_advise;          /* advice type */
    __u16 lla_value1;        /* values for different advice types */
    __u32 lla_value2;
    __u64 lla_start;         /* first byte of extent for advice */
    __u64 lla_end;           /* last byte of extent for advice */
    __u32 lla_value3;
    __u32 lla_value4;
};
```



```
};
```

42.6.2. Description

The `llapi_ladvise` function passes an array of `num_advise` I/O hints (up to a maximum of `LAH_COUNT_MAX` items) in `ladvise` for the file descriptor `fd` from an application to one or more Lustre servers. Optionally, `flags` can modify how the advice will be processed via bitwise-or'd values:

- `LF_ASYNC`: Clients return to userspace immediately after submitting `ladvise` RPCs, leaving server threads to handle the advices asynchronously.
- `LF_UNSET`: Unset/clear a previous advice (Currently only supports `LU_ADVICE_LOCKNOEXPAND`).

Each of the `ladvise` elements is an `llapi_lu_ladvise` structure, which contains the following fields:

Field	Description
<code>lla_ladvise</code>	Specifies the advice for the given file range, currently one of: <code>LU_LADVISE_WILLREAD</code> : Prefetch data into server cache using optimum I/O size for the server. <code>LU_LADVISE_DONTNEED</code> : Clean cached data for the specified file range(s) on the server.
<code>lla_start</code>	The offset in bytes for the start of this advice.
<code>lla_end</code>	The offset in bytes (non-inclusive) for the end of this advice.
<code>lla_value1</code> <code>lla_value2</code> <code>lla_value3</code> <code>lla_value4</code>	Additional arguments for future advice types and should be set to zero if not explicitly required for a given advice type. Advice-specific names for these fields follow.
<code>lla_lockahead_mode</code>	When using <code>LU_ADVICE_LOCKAHEAD</code> , the 'lla_value1' field is used to communicate the requested lock mode, and can be referred to as <code>lla_lockahead_mode</code> .
<code>lla_peradvice_flags</code>	When using advices which support them, the 'lla_value2' field is used to communicate per-advice flags and can be referred to as 'lla_peradvice_flags'. Both <code>LF_ASYNC</code> and <code>LF_UNSET</code> are supported as peradvice flags.
<code>lla_lockahead_result</code>	When using <code>LU_ADVICE_LOCKAHEAD</code> , the 'lla_value3' field is used to communicate the result of the request, and can be referred to as <code>lla_lockahead_result</code> .

`llapi_ladvise()` forwards the advice to Lustre servers without guaranteeing how and when servers will react to the advice. Actions may or may not be triggered when the advices are received, depending on the type of the advice as well as the real-time decision of the affected server-side components.

A typical usage of `llapi_ladvise()` is to enable applications and users (via `lfs_ladvise`) with external knowledge about application I/O patterns to intervene in server-side I/O handling. For example, if a group of different clients are doing small random reads of a file, prefetching pages into OSS cache with big linear reads before the random IO is an overall net benefit. Fetching that data into each client cache with `ladvise()` may not be beneficial, due to much more data being sent to the clients.

`LU_LADVISE_LOCKAHEAD` merits a special comment. While it is possible and encouraged to use it directly in your application to avoid lock contention (primarily for writing to a single file from multiple clients), it will also be available in the MPI-I/O / MPICH library from ANL for use with the `i/o` aggregation mode of that library. This is intended (eventually) to be the primary way this feature is used.

At the time of writing, this support is proposed as a patch but is not yet merged in to the public ANL code base. Users are encouraged to check their MPICH documentation and/or check with their library provider about support.

While conceptually similar to the `posix_fadvise` and Linux `fadvise` system calls, the main difference of `llapi_ladvise()` is that `fadvise()/posix_fadvise()` are client side mechanisms that do not pass advice to the filesystem, while `llapi_ladvise()` sends advice or hints to one or more Lustre servers on which the file is stored. In some cases it may be desirable to use both interfaces.

42.6.3. Return Values

`llapi_ladvise` returns:

0 On success

-1 if an error occurred (in which case, `errno` is set appropriately).

42.6.4. Errors

Error	Description
ENOMEM	Insufficient memory to complete operation.
EINVAL	One or more invalid arguments are given.
EFAULT	Memory region pointed by <code>ladvise</code> is not properly mapped.
ENOTSUPP	Advice type is not supported.

42.7. Example Using the llapi Library

Use `llapi_file_create` to set Lustre software properties for a new file. For a synopsis and description of `llapi_file_create` and examples of how to use it, see Chapter 43, *Configuration Files and Module Parameters*.

You can set striping from inside programs like `ioctl`. To compile the sample program, you need to install the Lustre client source RPM.

A simple C program to demonstrate striping API - `libtest.c`

```
/* -*- mode: c; c-basic-offset: 8; indent-tabs-mode: nil; -*-  
 * vim:expandtab:shiftwidth=8:tabstop=8:
```

Setting Lustre Properties
in a C Program (llapi)

```
*
* lustredemo - a simple example of lustreapi functions
*/
#include <stdio.h>
#include <fcntl.h>
#include <dirent.h>
#include <errno.h>
#include <stdlib.h>
#include <lustre/lustreapi.h>
#define MAX_OSTS 1024
#define LOV_EA_SIZE(lum, num) (sizeof(*lum) + num * sizeof(*lum->lmm_objects))
#define LOV_EA_MAX(lum) LOV_EA_SIZE(lum, MAX_OSTS)

/*
* This program provides crude examples of using the lustreapi API functions
*/
/* Change these definitions to suit */

#define TESTDIR "/tmp"           /* Results directory */
#define TESTFILE "lustre_dummy" /* Name for the file we create/destroy */
#define FILESIZE 262144         /* Size of the file in words */
#define DUMWORD "DEADBEEF"     /* Dummy word used to fill files */
#define MY_STRIPE_WIDTH 2      /* Set this to the number of OST required */
#define MY_LUSTRE_DIR "/mnt/lustre/ftest"

int close_file(int fd)
{
    if (close(fd) < 0) {
        fprintf(stderr, "File close failed: %d (%s)\n", errno, strerror(errno));
        return -1;
    }
    return 0;
}

int write_file(int fd)
{
    char *stng = DUMWORD;
    int cnt = 0;

    for( cnt = 0; cnt < FILESIZE; cnt++) {
        write(fd, stng, sizeof(stng));
    }
    return 0;
}

/* Open a file, set a specific stripe count, size and starting OST
* Adjust the parameters to suit */
int open_stripe_file()
{
    char *tfile = TESTFILE;
    int stripe_size = 65536; /* System default is 4M */
    int stripe_offset = -1; /* Start at default */
    int stripe_count = MY_STRIPE_WIDTH; /*Single stripe for this demo*/
    int stripe_pattern = 0; /* only RAID 0 at this time */
    int rc, fd;
```

```
rc = llapi_file_create(tfile,
                      stripe_size,stripe_offset,stripe_count,stripe_pattern);
/* result code is inverted, we may return -EINVAL or an ioctl error.
 * We borrow an error message from sanity.c
 */
if (rc) {
    fprintf(stderr,"llapi_file_create failed: %d (%s) \n", rc, strerror(errno));
    return -1;
}
/* llapi_file_create closes the file descriptor, we must re-open */
fd = open(tfile, O_CREAT | O_RDWR | O_LOV_DELAY_CREATE, 0644);
if (fd < 0) {
    fprintf(stderr, "Can't open %s file: %d (%s)\n", tfile, errno, strerror(errno));
    return -1;
}
return fd;
}

/* output a list of uuids for this file */
int get_my_uuids(int fd)
{
    struct obd_uuid uuids[1024], *uuidp;          /* Output var */
    int obdcount = 1024;
    int rc,i;

    rc = llapi_lov_get_uuids(fd, uuids, &obdcount);
    if (rc != 0) {
        fprintf(stderr, "get uuids failed: %d (%s)\n",errno, strerror(errno));
    }
    printf("This file system has %d obds\n", obdcount);
    for (i = 0, uuidp = uuids; i < obdcount; i++, uuidp++) {
        printf("UUID %d is %s\n",i, uuidp->uuid);
    }
    return 0;
}

/* Print out some LOV attributes. List our objects */
int get_file_info(char *path)
{
    struct lov_user_md *lump;
    int rc;
    int i;

    lump = malloc(LOV_EA_MAX(lump));
    if (lump == NULL) {
        return -1;
    }

    rc = llapi_file_get_stripe(path, lump);

    if (rc != 0) {
        fprintf(stderr, "get_stripe failed: %d (%s)\n",errno, strerror(errno));
    }
}
```

```

        return -1;
    }

    printf("Lov magic %u\n", lump->lmm_magic);
    printf("Lov pattern %u\n", lump->lmm_pattern);
    printf("Lov object id %llu\n", lump->lmm_object_id);
    printf("Lov stripe size %u\n", lump->lmm_stripe_size);
    printf("Lov stripe count %hu\n", lump->lmm_stripe_count);
    printf("Lov stripe offset %u\n", lump->lmm_stripe_offset);
    for (i = 0; i < lump->lmm_stripe_count; i++) {
        printf("Object index %d Objid %llu\n", lump->lmm_objects[i].l_ost
    }

    free(lump);
    return rc;
}

/* Ping all OSTs that belong to this filesystem */
int ping_osts()
{
    DIR *dir;
    struct dirent *d;
    char osc_dir[100];
    int rc;

    sprintf(osc_dir, "/proc/fs/lustre/osc");
    dir = opendir(osc_dir);
    if (dir == NULL) {
        printf("Can't open dir\n");
        return -1;
    }
    while((d = readdir(dir)) != NULL) {
        if ( d->d_type == DT_DIR ) {
            if (! strcmp(d->d_name, "OSC", 3)) {
                printf("Pinging OSC %s ", d->d_name);
                rc = llapi_ping("osc", d->d_name);
                if (rc) {
                    printf(" bad\n");
                } else {
                    printf(" good\n");
                }
            }
        }
    }
    return 0;
}

int main()
{
    int file;
    int rc;
    char filename[100];

```

```
char sys_cmd[100];

sprintf(filename, "%s/%s", MY_LUSTRE_DIR, TESTFILE);

printf("Open a file with striping\n");
file = open_stripe_file();
if ( file < 0 ) {
    printf("Exiting\n");
    exit(1);
}
printf("Getting uid list\n");
rc = get_my_uuids(file);
printf("Write to the file\n");
rc = write_file(file);
rc = close_file(file);
printf("Listing LOV data\n");
rc = get_file_info(filename);
printf("Ping our OSTs\n");
rc = ping_osts();

/* the results should match lfs getstripe */
printf("Confirming our results with lfs getstripe\n");
sprintf(sys_cmd, "/usr/bin/lfs getstripe %s/%s", MY_LUSTRE_DIR, TESTFILE);
system(sys_cmd);

printf("All done\n");
exit(rc);
}
```

Makefile for sample application:

```
gcc -g -O2 -Wall -o lustredemo libtest.c -llustreapi
clean:
rm -f core lustredemo *.o
run:
make
rm -f /mnt/lustre/ftest/lustredemo
rm -f /mnt/lustre/ftest/lustre_dummy
cp lustredemo /mnt/lustre/ftest/
```

42.7.1. See Also

- Section 42.1, “llapi_file_create”
- Section 42.2, “llapi_file_get_stripe”
- Section 42.3, “llapi_file_open”
- Section 42.4, “llapi_quotactl”

Chapter 43. Configuration Files and Module Parameters

This section describes configuration files and module parameters and includes the following sections:

- Section 43.1, “Introduction”
- Section 43.2, “Module Options”

43.1. Introduction

LNet network hardware and routing are now configured via module parameters. Parameters should be specified in the `/etc/modprobe.d/lustre.conf` file, for example:

```
options lnet networks=tcp0(eth2)
```

The above option specifies that this node should use the TCP protocol on the eth2 network interface.

Module parameters are read when the module is first loaded. Type-specific LND modules (for instance, `ksocklnd`) are loaded automatically by the LNet module when LNet starts (typically upon `modprobe ptlrpc`).

LNet configuration parameters can be viewed under `/sys/module/lnet/parameters/`, and LND-specific parameters under the name of the corresponding LND, for example `/sys/module/ksocklnd/parameters/` for the `socklnd` (TCP) LND.

For the following parameters, default option settings are shown in parenthesis. Changes to parameters marked with a `W` affect running systems. Unmarked parameters can only be set when LNet loads for the first time. Changes to parameters marked with `Wc` only have effect when connections are established (existing connections are not affected by these changes.)

43.2. Module Options

- With routed or other multi-network configurations, use `ip2nets` rather than `networks`, so all nodes can use the same configuration.
- For a routed network, use the same 'routes' configuration everywhere. Nodes specified as routers automatically enable forwarding and any routes that are not relevant to a particular node are ignored. Keep a common configuration to guarantee that all nodes have consistent routing tables.
- A separate `lustre.conf` file makes distributing the configuration much easier.
- If you set `config_on_load=1`, LNet starts at `modprobe` time rather than waiting for the Lustre file system to start. This ensures routers start working at module load time.

```
# lctl
# lctl> net down
```

- Remember the `lctl ping {nid}` command - it is a handy way to check your LNet configuration.

43.2.1. LNet Options

This section describes LNet options.

43.2.1.1. Network Topology

Network topology module parameters determine which networks a node should join, whether it should route between these networks, and how it communicates with non-local networks.

Here is a list of various networks and the supported software stacks:

Network	Software Stack
o2ib	OFED Version 2

Note

The Lustre software ignores the loopback interface (100), but the Lustre file system uses any IP addresses aliased to the loopback (by default). When in doubt, explicitly specify networks.

43.2.1.2. ip2nets ("tcp")

`ip2nets` is a string that lists globally available networks, each with a set of IP address ranges. LNet determines the locally-available networks from this list by matching the IP address ranges with the local IPs of a node. Its purpose is to allow the same `modules.conf` file to be used across a variety of nodes on different networks. The string has the following syntax.

```

<ip2nets> ::= <net-match> [ <comment> ] { <net-sep> <net-match> }
<net-match> ::= [ <w> ] <net-spec> <w> <ip-range> { <w> <ip-range> }
[ <w> ]
<net-spec> ::= <network> [ "(" <interface-list> ")" ]
<network> ::= <nettype> [ <number> ]
<nettype> ::= "tcp" | "elan" | "o2ib" | ...
<iface-list> ::= <interface> [ "," <iface-list> ]
<ip-range> ::= <r-expr> "." <r-expr> "." <r-expr> "." <r-expr>
<r-expr> ::= <number> | "*" | "[" <r-list> "]"
<r-list> ::= <range> [ "," <r-list> ]
<range> ::= <number> [ "-" <number> [ "/" <number> ] ]
<comment> ::= "#" { <non-net-sep-chars> }
<net-sep> ::= ";" | "\n"
<w> ::= <whitespace-chars> { <whitespace-chars> }

```

`<net-spec>` contains enough information to uniquely identify the network and load an appropriate LND. The LND determines the missing "address-within-network" part of the NID based on the interfaces it can use.

`<iface-list>` specifies which hardware interface the network can use. If omitted, all interfaces are used. LNDs that do not support the `<iface-list>` syntax cannot be configured to use particular interfaces and just use what is there. Only a single instance of these LNDs can exist on a node at any time, and `<iface-list>` must be omitted.

`<net-match>` entries are scanned in the order declared to see if one of the node's IP addresses matches one of the `<ip-range>` expressions. If there is a match, `<net-spec>` specifies the network to

instantiate. Note that it is the first match for a particular network that counts. This can be used to simplify the match expression for the general case by placing it after the special cases. For example:

```
ip2nets="tcp(eth1,eth2) 134.32.1.[4-10/2]; tcp(eth1) *.*.*.*"
```

4 nodes on the 134.32.1.* network have 2 interfaces (134.32.1.{4,6,8,10}) but all the rest have 1.

```
ip2nets="o2ib 192.168.0.*; tcp(eth2) 192.168.0.[1,7,4,12]"
```

This describes an IB cluster on 192.168.0.*. Four of these nodes also have IP interfaces; these four could be used as routers.

Note that match-all expressions (For instance, *.*.*.*) effectively mask all other

<net-match> entries specified after them. They should be used with caution.

Here is a more complicated situation, the route parameter is explained below. We have:

- Two TCP subnets
- One Elan subnet
- One machine set up as a router, with both TCP and Elan interfaces
- IP over Elan configured, but only IP will be used to label the nodes.

```
options lnet ip2nets="tcp 198.129.135.* 192.128.88.98; \  
        elan 198.128.88.98 198.129.135.3; \  
        routes='cp 1022@elan # Elan NID of router; \  
        elan 198.128.88.98@tcp # TCP NID of router'
```

43.2.1.3. networks ("tcp")

This is an alternative to "ip2nets" which can be used to specify the networks to be instantiated explicitly. The syntax is a simple comma separated list of <net-spec>s (see above). The default is only used if neither 'ip2nets' nor 'networks' is specified.

43.2.1.4. routes ("")

This is a string that lists networks and the NIDs of routers that forward to them.

It has the following syntax (<w> is one or more whitespace characters):

```
<routes> ::= <route>{ ; <route> }  
<route> ::= [<net>[<w><hopcount>]<w><nid>[:<priority>]]{<w><nid>[:<priority>]}
```

Note: the priority parameter was added in release 2.5.

So a node on the network tcp1 that needs to go through a router to get to the Elan network:

```
options lnet networks=tcp1 routes="elan 1 192.168.2.2@tcpA"
```

The hopcount and priority numbers are used to help choose the best path between multiply-routed configurations.

A simple but powerful expansion syntax is provided, both for target networks and router NIDs as follows.

```
<expansion> ::= "[" <entry> { "," <entry> } "]"
<entry> ::= <numeric range> | <non-numeric item>
<numeric range> ::= <number> [ "-" <number> [ "/" <number> ] ]
```

The expansion is a list enclosed in square brackets. Numeric items in the list may be a single number, a contiguous range of numbers, or a strided range of numbers. For example, `routes="elan 192.168.1.[22-24]@tcp"` says that network `elan0` may be adjacent or behind another network (hopcount is undefined); and is accessible via 3 routers on the `tcp0` network (`192.168.1.22@tcp`, `192.168.1.23@tcp` and `192.168.1.24@tcp`).

`routes="[tcp,o2ib] 2 [8-14/2]@elan"` says that 2 networks (`tcp0` and `o2ib0`) are accessible through 4 routers (`8@elan`, `10@elan`, `12@elan` and `14@elan`). The hopcount of 2 means that traffic to both these networks will be traversed 2 routers - first one of the routers specified in this entry, then one more.

Duplicate entries, entries that route to a local network, and entries that specify routers on a non-local network are ignored.

Prior to release 2.5, a conflict between equivalent entries was resolved in favor of the route with the shorter hopcount. The hopcount, if omitted, is undefined, but is treated as 1 when being compared to other routes during selection (as if the remote network is adjacent).

Introduced in Lustre 2.5

Since 2.5, equivalent entries are resolved in favor of the route with the lowest priority number or shorter hopcount if the priorities are equal. The priority, if omitted, defaults to 0. The hopcount, if omitted, is undefined, but is treated as 1 when being compared to other routes during selection (as if the remote network is adjacent).

It is an error to specify routes to the same destination with routers on different local networks.

If a route string contains no hop count, then the hop count is undefined. Explicitly setting the hop count to 1 is recommended if the remote network is adjacent and `avoid_asym_router_failure` is enabled to ensure proper operation of the feature.

43.2.1.5. forwarding ("")

This is a string that can be set either to "enabled" or "disabled" for explicit control of whether this node should act as a router, forwarding communications between all local networks.

A standalone router can be started by simply starting LNet (`modprobe ptlrpc`) with appropriate network topology options.

43.2.1.6. accept (secure)

The acceptor is a TCP/IP service that some LNDs use to establish communications. If a local network requires it and it has not been disabled, the acceptor listens on a single port for connection requests that it redirects to the appropriate local network. The acceptor is part of the LNet module and configured by the following options:

Variable	Description
<code>accept</code> (<code>secure</code>)	The type of connections that the acceptor will allow from remote nodes.

Variable	Description
	<ul style="list-style-type: none"> • <code>secure</code> - Accept connections only from reserved TCP ports (below 1023). This is the default, and prevents userspace processes from trying to connect to the server. • <code>all</code> - Accept connections from any TCP port. This may be needed to allow connections on non-privileged ports, for example from a client in a virtual machine running in userspace. • <code>none</code> - Do not run the acceptor. This may prevent the client from receiving server RPCs if the TCP connection is lost and the server needs to contact the client for some reason (e.g. LDLM lock callback or size glimpse).
<code>accept_port</code> (988)	Port number on which the acceptor should listen for connection requests. All nodes in a site configuration that require an acceptor must use the same port.
<code>accept_backlog</code> (127)	Maximum length that the queue of pending connections may grow to (see <code>listen(2)</code>).
<code>accept_timeout</code> (5, W)	Maximum time in seconds the acceptor is allowed to block while communicating with a peer.
<code>accept_proto_version</code>	Version of the acceptor protocol that should be used by outgoing connection requests. It defaults to the most recent acceptor protocol version, but it may be set to the previous version to allow the node to initiate connections with nodes that only understand that version of the acceptor protocol. The acceptor can, with some restrictions, handle either version (that is, it can accept connections from both 'old' and 'new' peers). For the current version of the acceptor protocol (version 1), the acceptor is compatible with old peers if it is only required by a single local network.

43.2.1.7. `rnet_hhtable_size`

`rnet_hhtable_size` is an integer that indicates how many remote networks the internal LNet hash table is configured to handle. `rnet_hhtable_size` is used for optimizing the hash table size and does not put a limit on how many remote networks you can have. The default hash table size when this parameter is not specified is: 128.

43.2.2. `SOCKLND` Kernel TCP/IP LND

The `SOCKLND` kernel TCP/IP LND (`socklnd`) is connection-based and uses the acceptor to establish communications via sockets with its peers.

It supports multiple instances and load balances dynamically over multiple interfaces. If no interfaces are specified by the `ip2nets` or `networks` module parameter, all non-loopback IP interfaces are used. The

address-within-network is determined by the address of the first IP interface an instance of the `socklnd` encounters.

Consider a node on the 'edge' of an InfiniBand network, with a low-bandwidth management Ethernet (`eth0`), IP over IB configured (`ipoib0`), and a pair of GigE NICs (`eth1,eth2`) providing off-cluster connectivity. This node should be configured with '`networks=o2ib,tcp(eth1,eth2)`' to ensure that the `socklnd` ignores the management Ethernet and IPoIB.

Variable	Description
<code>timeout</code> (50,W)	Time (in seconds) that communications may be stalled before the LND completes them with failure.
<code>nconnds</code> (4)	Sets the number of connection daemons.
<code>min_reconnectms</code> (1000,W)	Minimum connection retry interval (in milliseconds). After a failed connection attempt, this is the time that must elapse before the first retry. As connections attempts fail, this time is doubled on each successive retry up to a maximum of ' <code>max_reconnectms</code> '.
<code>max_reconnectms</code> (6000,W)	Maximum connection retry interval (in milliseconds).
<code>eager_ack</code> (0 on linux, 1 on darwin,W)	Boolean that determines whether the <code>socklnd</code> should attempt to flush sends on message boundaries.
<code>typed_conns</code> (1,Wc)	Boolean that determines whether the <code>socklnd</code> should use different sockets for different types of messages. When clear, all communication with a particular peer takes place on the same socket. Otherwise, separate sockets are used for bulk sends, bulk receives and everything else.
<code>min_bulk</code> (1024,W)	Determines when a message is considered "bulk".
<code>tx_buffer_size, rx_buffer_size</code> (8388608,Wc)	Socket buffer sizes. Setting this option to zero (0), allows the system to auto-tune buffer sizes. Warning Be very careful changing this value as improper sizing can harm performance.
<code>nagle</code> (0,Wc)	Boolean that determines if <code>nagle</code> should be enabled. It should never be set in production systems.
<code>keepalive_idle</code> (30,Wc)	Time (in seconds) that a socket can remain idle before a keepalive probe is sent. Setting this value to zero (0) disables keepalives.

Configuration Files
and Module Parameters

Variable	Description
keepalive_intvl (2,Wc)	Time (in seconds) to repeat unanswered keepalive probes. Setting this value to zero (0) disables keepalives.
keepalive_count (10,Wc)	Number of unanswered keepalive probes before pronouncing socket (hence peer) death.
enable_irq_affinity (0,Wc)	Boolean that determines whether to enable IRQ affinity. The default is zero (0). When set, socklnd attempts to maximize performance by handling device interrupts and data movement for particular (hardware) interfaces on particular CPUs. This option is not available on all platforms. This option requires an SMP system to exist and produces best performance with multiple NICs. Systems with multiple CPUs and a single NIC may see increase in the performance with this parameter disabled.
zc_min_frag (2048,W)	Determines the minimum message fragment that should be considered for zero-copy sends. Increasing it above the platform's PAGE_SIZE disables all zero copy sends. This option is not available on all platforms.

Chapter 44. System Configuration Utilities

This chapter includes system configuration utilities and includes the following sections:

- Section 44.1, “l_getidentity”
- Section 44.2, “lctl”
- Section 44.3, “ll_decode_filter_fid”
- Section 44.5, “llog_reader”
- Section 44.6, “llstat”
- Section 44.7, “llverdev”
- Section 44.8, “lshowmount”
- Section 44.9, “lst”
- Section 44.10, “lustre_rmmod.sh”
- Section 44.11, “lustre_rsync”
- Section 44.12, “mkfs.lustre”
- Section 44.13, “mount.lustre”
- Section 44.14, “routerstat”
- Section 44.15, “tunefs.lustre”
- Section 44.16, “Additional System Configuration Utilities”

44.1. l_getidentity

The `l_getidentity` tool normally handles Lustre user/group mapping upcall.

44.1.1. Synopsis

```
l_getidentity { $FSNAME-MDT{xxxx}| -d } {uid}
```

44.1.2. Description

The `l_getidentity` utility is called from the MDS to map a numeric UID value into the list of supplementary group values for that UID, and writes this into the `mdt.*.identity_info` parameter file. The list of supplementary groups is cached in the kernel to avoid repeated upcalls. See Section 41.1, “User/Group Upcall” for more details.

The `l_getidentity` utility can also be run directly for debugging purposes to ensure that the UID mapping for a particular user is configured correctly, by using the `-d` argument instead of the MDT name.

44.1.3. Options

Option	Description
<code>\${FSNAME} -MDT{xxxx}</code>	Metadata server target name
<code>uid</code>	User identifier

44.1.4. Files

The parameter to set the `l_getidentity` path is:

```
mgs# lctl set_param -P mdt.*-MDT*.identity_upcall=path
```

44.2. lctl

The `lctl` utility is used for root control and configuration. With `lctl` you can directly control Lustre via an `ioctl` interface, allowing various configuration, maintenance and debugging features to be accessed.

44.2.1. Synopsis

```
lctl [--device devno] command [args]
```

44.2.2. Description

The `lctl` utility can be invoked in interactive mode by issuing the `lctl` command. After that, commands are issued as shown below. The most common `lctl` commands are:

```
dl
dk
device
network up/down
list_nids
ping nidhelp
quit
```

For a complete list of available commands, type `help` at the `lctl` prompt. To get basic help on command meaning and syntax, type `help command`. Command completion is activated with the TAB key (depending on compile options), and command history is available via the up- and down-arrow keys.

For non-interactive use, use the second invocation, which runs the command after connecting to the device.

44.2.3. Setting Parameters with lctl

Lustre parameters are not always accessible using the `procs` interface, as it is platform-specific. As a solution, `lctl {get,set}_param` provides a platform-independent interface to the Lustre tunables. Avoid any direct references to `/proc` and `/sys` files in scripts. For future portability, instead use `lctl {get,set}_param`, which handles these details internally.

When the file system is running, use the `lctl set_param` command on the affected node(s) to temporarily set parameters (mapping to items in). The `lctl set_param` command uses this syntax:

```
lctl set_param [-n] [-P] [-d] obdtype.obdname.property=value
```

For example:

```
mgs# lctl set_param mdt.testfs-MDT0000.identity_upcall=NONE
```

Introduced in Lustre 2.5

Use `-P` option to set parameters permanently. Option `-d` deletes permanent parameters. For example:

```
mgs# lctl set_param -P mdt.testfs-MDT0000.identity_upcall=NONE
mgs# lctl set_param -P -d mdt.testfs-MDT0000.identity_upcall
```

Many permanent parameters can be set with the `lctl conf_param` utility. In general, `lctl conf_param` can be used to specify any OBD device parameter settable in a `/proc/fs/lustre` file. The `lctl conf_param` command must be run on the MGS node, and uses this syntax:

```
obd/fsname.obdtype.property=value)
```

For example:

```
mgs# lctl conf_param testfs-MDT0000.mdt.identity_upcall=NONE
$ lctl conf_param testfs.llite.max_read_ahead_mb=16
```

Caution

The `lctl conf_param` command *permanently* sets parameters in the file system configuration for all nodes of the specified type.

To get current Lustre parameter settings, use the `lctl get_param` command on the desired node with the same parameter name as `lctl set_param`:

```
# lctl get_param [-n] obdtype.obdname.parameter
```

For example:

```
mgs# lctl get_param mdt.testfs-MDT0000.identity_upcall
```

To list Lustre parameters that are available to set, use the `lctl list_param` command, with this syntax:

```
# lctl list_param [-R] [-F] obdtype.obdname.*
```

For example, to list all of the parameters on the MDT:

```
oss# lctl list_param -RF mdt
```

For more information on using `lctl` to set temporary and permanent parameters, see Section 13.12.3, “Setting Parameters with `lctl`”.

Network Configuration

Option	Description
network up down tcp elan	Starts or stops LNet, or selects a network type for other <code>lctl</code> LNet commands.
list_nids	Prints all NIDs on the local node. LNet must be running.

Option	Description
<code>which_nid <i>nidlist</i></code>	From a list of NIDs for a remote node, identifies the NID on which interface communication will occur.
<code>ping <i>nid</i></code>	Checks LNet connectivity via an LNet ping. This uses the fabric appropriate to the specified NID.
<code>interface_list</code>	Prints the network interface information for a given <i>network</i> type.
<code>peer_list</code>	Prints the known peers for a given <i>network</i> type.
<code>conn_list</code>	Prints all the connected remote NIDs for a given <i>network</i> type.
<code>active_tx</code>	This command prints active transmits. It is only used for the Elan <i>network</i> type.
<code>route_list</code>	Prints the complete routing table.

Device Selection

Option	Description
<code>device <i>devname</i></code>	This selects the specified OBD device. All other commands depend on the device being set.
<code>device_list</code>	Shows the local Lustre OBDs, a/k/a d1.

Device Operations

Option	Description	
<code>list_param [-F -R] <i>parameter</i> [<i>parameter</i> ...]</code>	Lists the Lustre or LNet parameter name.	
	-F	Adds '/', '@' or '=' for directories, symlinks and writeable files, respectively.
	-R	Recursively lists all parameters under the specified path. If <i>param_path</i> is unspecified, all parameters are shown.
<code>get_param [-n -N -F] <i>parameter</i> [<i>parameter</i> ...]</code>	Gets the value of a Lustre or LNet parameter from the specified path.	
	-n	Prints only the parameter value and not the parameter name.
	-N	Prints only matched parameter names and not the values; especially useful when using patterns.
	-F	When -N is specified, adds '/', '@' or '=' for directories, symlinks and writeable files, respectively.

Option	Description
set_param [-n] <i>parameter=value</i>	Sets the value of a Lustre or LNet parameter from the specified path.
	-n Disables printing of the key name when printing values.
conf_param [-d] <i>device/fsname parameter=value</i>	<p>Sets a permanent configuration parameter for any device via the MGS. This command must be run on the MGS node.</p> <p>All writeable parameters under <code>lctl list_param</code> (e.g. <code>lctl list_param -F osc.*.* grep =</code>) can be permanently set using <code>lctl conf_param</code>, but the conversion of <code>list_param</code> names to <code>conf_param</code> names is not obvious, so it is preferred to use the <code>set_param -P</code> command.</p> <p>For more information on setting permanent parameters, see Section 13.12.3.2, “Setting Permanent Parameters” (Setting Permanent Parameters).</p>
	-d <i>device/fsname.parameter</i> Deletes a parameter setting (use the default value at the next restart). A null value for <i>value</i> also deletes the parameter setting.
activate	Re-activates an import after the deactivate operation. This setting is only effective until the next restart (see <code>conf_param</code>).
deactivate	Deactivates an import, in particular meaning do not assign new file stripes to an OSC. Running <code>lctl deactivate</code> on the MDS stops new objects from being allocated on the OST. Running <code>lctl deactivate</code> on Lustre clients causes them to return -EIO when accessing objects on the OST instead of waiting for recovery.
abort_recovery	Aborts the recovery process on a re-starting MDT or OST.

Note

Lustre tunables are not always accessible using the procfs interface, as it is platform-specific. As a solution, `lctl {get,set,list}_param` has been introduced as a platform-independent interface to the Lustre tunables. Avoid direct references to `/proc/{fs,sys}/{lustre,lnet}`. For future portability, use `lctl {get,set,list}_param` instead.

Virtual Block Device Operations

Lustre can emulate a virtual block device upon a regular file. This emulation is needed when you are trying to set up a swap space via the file.

Option	Description
<code>blockdev_attach filename /dev/loop_device</code>	Attaches a regular Lustre file to a block device. If the device node does not exist, <code>lctl</code> creates it. It is recommended that a device node is created by <code>lctl</code> since the emulator uses a dynamical major number.
<code>blockdev_detach /dev/loop_device</code>	Detaches the virtual block device.
<code>blockdev_info /dev/loop_device</code>	Provides information about the Lustre file attached to the device node.

Changelogs

Option	Description
<code>changelog_register</code>	Registers a new changelog user for a particular device. Changelog entries are saved persistently on the MDT with each filesystem operation, and are only purged beyond all registered user's minimum set point (see <code>lfs changelog_clear</code>). This may cause the Changelog to consume a large amount of space, eventually filling the MDT, if a changelog user is registered but never consumes those records.
<code>changelog_deregister id</code>	Unregisters an existing changelog user. If the user's "clear" record number is the minimum for the device, changelog records are purged until the next minimum.

Debug

Option	Description
<code>debug_daemon</code>	Starts and stops the debug daemon, and controls the output filename and size.
<code>debug_kernel [file] [raw]</code>	Dumps the kernel debug buffer to stdout or a file.
<code>debug_file input_file [output_file]</code>	Converts the kernel-dumped debug log from binary to plain text format.
<code>clear</code>	Clears the kernel debug buffer.
<code>mark text</code>	Inserts marker text in the kernel debug buffer.
<code>filter subsystem_id/debug_mask</code>	Filters kernel debug messages by subsystem or mask.
<code>show subsystem_id/debug_mask</code>	Shows specific types of messages.

Option	Description
<code>debug_list subsystems/types</code>	Lists all subsystem and debug types.
<code>modules path</code>	Provides GDB-friendly module information.

44.2.4. Options

Use the following options to invoke `lctl`.

Option	Description
<code>--device</code>	Device to be used for the operation (specified by name or number). See <code>device_list</code> .
<code>--ignore_errors</code> <code>ignore_errors</code>	Ignores errors during script processing.

44.2.5. Examples

```
lctl
$ lctl
lctl > dl
  0 UP mgc MGC192.168.0.20@tcp btbb24e3-7deb-2ffa-eab0-44dffe00f692 5
  1 UP ost OSS OSS_uuid 3
  2 UP obdfilter testfs-OST0000 testfs-OST0000_UUID 3
lctl > dk /tmp/log Debug log: 87 lines, 87 kept, 0 dropped.
lctl > quit
```

44.2.6. See Also

- Section 44.12, “`mkfs.lustre`”
- Section 44.13, “`mount.lustre`”
- Section 44.2, “`lctl`”
- Section 40.1, “`lfs`”

44.3. `ll_decode_filter_fid`

The `ll_decode_filter_fid` utility displays the Lustre object ID and MDT parent FID.

44.3.1. Synopsis

```
ll_decode_filter_fid object_file [object_file ...]
```

44.3.2. Description

The `ll_decode_filter_fid` utility decodes and prints the Lustre OST object ID, MDT FID, stripe index for the specified OST object(s), which is stored in the “`trusted.fid`” attribute on each OST object. This is accessible to `ll_decode_filter_fid` when the OST file system is mounted locally as type `ldisks` for maintenance.

The “`trusted.fid`” extended attribute is stored on each OST object when it is first modified (data written or attributes set), and is not accessed or modified by Lustre after that time.

The OST object ID (objid) may be useful in case of OST directory corruption, though LFSCK can normally reconstruct the entire OST object directory tree, see Section 36.4, “Checking the file system with LFSCK” for details. The MDS FID can be useful to determine which MDS inode an OST object is (or was) used by. The stripe index can be used in conjunction with other OST objects to reconstruct the layout of a file even if the MDT inode was lost.

44.3.3. Examples

```
root@oss1# cd /mnt/ost/lost+found
root@oss1# ll_decode_filter_fid #123454 #123455 #123458
#123454: objid=690670 seq=0 parent=[0x751c5:0xfce6e605:0x0]
#123455: objid=614725 seq=0 parent=[0x18d11:0xebba84eb:0x1]
#123458: objid=533088 seq=0 parent=[0x21417:0x19734d61:0x0]
```

This shows that the three files in lost+found have decimal object IDs - 690670, 614725, and 533088, respectively. The object sequence number (formerly object group) is 0 for all current OST objects.

The MDT parent inode FIDs are hexadecimal numbers of the form sequence:oid:idx. Since the sequence number is below 0x100000000 in all these cases, the FIDs are in the legacy Inode and Generation In FID (IGIF) namespace and are mapped directly to the MDT inode = seq and generation = oid values; the MDT inodes are 0x751c5, 0x18d11, and 0x21417 respectively. For objects with MDT parent sequence numbers above 0x200000000, this indicates that the FID needs to be mapped via the MDT Object Index (OI) file on the MDT to determine the internal inode number.

The idx field shows the stripe number of this OST object in the Lustre RAID-0 striped file.

44.4. llobdstat

The llobdstat utility displays the Lustre object ID and MDT parent FID.

44.4.1. Synopsis

```
llobdstat ost_name [interval]
```

44.4.2. Description

The llobdstat utility displays a line of OST statistics for the given ost_name every interval seconds. It should be run directly on an OSS node. Type CTRL-C to stop statistics printing.

44.4.3. Example

```
# llobdstat liane-OST0002 1
/usr/bin/llobdstat on /proc/fs/lustre/obdfilter/liane-OST0002/stats
Processor counters run at 2800.189 MHz
Read: 1.21431e+07, Write: 9.93363e+08, create/destroy: 24/1499, stat: 34, p\
unch: 18
[NOTE: cx: create, dx: destroy, st: statfs, pu: punch ]
Timestamp Read-delta ReadRate Write-delta WriteRate
-----
1217026053 0.00MB 0.00MB/s 0.00MB 0.00MB/s
1217026054 0.00MB 0.00MB/s 0.00MB 0.00MB/s
1217026055 0.00MB 0.00MB/s 0.00MB 0.00MB/s
1217026056 0.00MB 0.00MB/s 0.00MB 0.00MB/s
```

```
1217026057 0.00MB 0.00MB/s 0.00MB 0.00MB/s
1217026058 0.00MB 0.00MB/s 0.00MB 0.00MB/s
1217026059 0.00MB 0.00MB/s 0.00MB 0.00MB/s st:1
```

44.4.4. Files

```
/proc/fs/lustre/obdfilter/ostname/stats
```

44.5. llog_reader

The `llog_reader` utility translates a Lustre configuration log into human-readable form.

44.5.1. Synopsis

```
llog_reader filename
```

44.5.2. Description

The `llog_reader` utility parses the binary format of Lustre's on-disk configuration logs. `Llog_reader` can only read logs; use `tunefs.lustre` to write to them.

To examine a log file on a stopped Lustre server, mount its backing file system as `ldiskfs` or `zfs`, then use `llog_reader` to dump the log file's contents, for example:

```
mount -t ldiskfs /dev/sda /mnt/mgs
llog_reader /mnt/mgs/CONFIGS/tfs-client
```

To examine the same log file on a running Lustre server, use the `ldiskfs`-enabled `debugfs` utility (called `debug.ldiskfs` on some distributions) to extract the file, for example:

```
debugfs -c -R 'dump CONFIGS/tfs-client /tmp/tfs-client' /dev/sda
llog_reader /tmp/tfs-client
```

Caution

Although they are stored in the `CONFIGS` directory, `mountdata` files do not use the configuration log format and will confuse the `llog_reader` utility.

44.5.3. See Also

Section 44.15, “`tunefs.lustre`”

44.6. llstat

44.6.1. Synopsis

```
llstat [-c] [-g] [-i interval] stats_file
```

44.6.2. Description

The `llstat` utility displays statistics from any of the Lustre statistics parameter files on the local node that share a common format and are updated at `interval` seconds. To stop stats printing, use `CTRL-C`.

44.6.3. Options

Option	Description
-c	Clears the statistics file.
-i	Specifies the polling period (in seconds).
-g	Specifies graphable output format.
-h	Displays help information.
stats_file	Specifies either the full path to a statistics file or the shorthand reference, <code>mds</code> or <code>ost</code>

44.6.4. Example

To monitor `/proc/fs/lustre/ost/OSS/ost/stats` at 1 second intervals, run;

```
llstat -i 1 ost
```

44.6.5. Files

The `llstat` files are located at:

```
/proc/fs/lustre/mdt/MDS/*/stats
/proc/fs/lustre/mdt/*/exports/*/stats
/proc/fs/lustre/mdc/*/stats
/proc/fs/lustre/ldlm/services/*/stats
/proc/fs/lustre/ldlm/namespaces/*/pool/stats
/proc/fs/lustre/mgs/MGS/exports/*/stats
/proc/fs/lustre/ost/OSS/*/stats
/proc/fs/lustre/osc/*/stats
/proc/fs/lustre/obdfilter/*/exports/*/stats
/proc/fs/lustre/obdfilter/*/stats
/proc/fs/lustre/llite/*/stats
```

44.7. llverdev

The `llverdev` verifies a block device is functioning properly over its full size.

44.7.1. Synopsis

```
llverdev [-c chunksize] [-f] [-h] [-o offset] [-l] [-p] [-r] [-t timestamp] [-v] [
```

44.7.2. Description

Sometimes kernel drivers or hardware devices have bugs that prevent them from accessing the full device size correctly, or possibly have bad sectors on disk or other problems which prevent proper data storage. There are often defects associated with major system boundaries such as 2^{32} bytes, 2^{31} sectors, 2^{31} blocks, 2^{32} blocks, etc.

The `llverdev` utility writes and verifies a unique test pattern across the entire device to ensure that data is accessible after it was written, and that data written to one part of the disk is not overwriting data on another part of the disk.

It is expected that `llverdev` will be run on large size devices (TB). It is always better to run `llverdev` in verbose mode, so that device testing can be easily restarted from the point where it was stopped.

Running a full verification can be time-consuming for very large devices. We recommend starting with a partial verification to ensure that the device is minimally sane before investing in a full verification.

44.7.3. Options

Option	Description
<code>-c --chunksize</code>	I/O chunk size in bytes (default value is 1048576).
<code>-f --force</code>	Forces the test to run without a confirmation that the device will be overwritten and all data will be permanently destroyed.
<code>-h --help</code>	Displays a brief help message.
<code>-o <i>offset</i></code>	Offset (in kilobytes) of the start of the test (default value is 0).
<code>-l --long</code>	Runs a full check, writing and then reading and verifying every block on the disk.
<code>-p --partial</code>	Runs a partial check, only doing periodic checks across the device (1 GB steps).
<code>-r --read</code>	Runs the test in read (verify) mode only, after having previously run the test in <code>-w</code> mode.
<code>-t <i>timestamp</i></code>	Sets the test start time as printed at the start of a previously-interrupted test to ensure that validation data is the same across the entire file system (default value is the current time()).
<code>-v --verbose</code>	Runs the test in verbose mode, listing each read and write operation.
<code>-w --write</code>	Runs the test in write (test-pattern) mode (default runs both read and write).

44.7.4. Examples

Runs a partial device verification on `/dev/sda`:

```
llverdev -v -p /dev/sda
llverdev: permanently overwrite all data on /dev/sda (yes/no)? y
llverdev: /dev/sda is 4398046511104 bytes (4096.0 GB) in size
Timestamp: 1009839028
Current write offset: 4096 kB
```

Continues an interrupted verification at offset 4096kB from the start of the device, using the same timestamp as the previous run:

```
llverdev -f -v -p --offset=4096 --timestamp=1009839028 /dev/sda
llverdev: /dev/sda is 4398046511104 bytes (4096.0 GB) in size
Timestamp: 1009839028
write complete
read complete
```

44.8. Lshowmount

The lshowmount utility shows Lustre exports.

44.8.1. Synopsis

```
lshowmount [-ehlv]
```

44.8.2. Description

The lshowmount utility shows the hosts that have Lustre mounted to a server. This utility looks for exports from the MGS, MDS, and obdfilter.

44.8.3. Options

Option	Description
<code>-e</code> <code>--enumerate</code>	Causes lshowmount to list each client mounted on a separate line instead of trying to compress the list of clients into a hostrange string.
<code>-h</code> <code>--help</code>	Causes lshowmount to print out a usage message.
<code>-l</code> <code>--lookup</code>	Causes lshowmount to try to look up the hostname for NIDs that look like IP addresses.
<code>-v</code> <code>--verbose</code>	Causes lshowmount to output export information for each service instead of only displaying the aggregate information for all Lustre services on the server.

44.8.4. Files

```
/proc/fs/lustre/mgs/server/exports/uuid/nid
/proc/fs/lustre/mds/server/exports/uuid/nid
/proc/fs/lustre/obdfilter/server/exports/uuid/nid
```

44.9. Lst

The lst utility starts LNet self-test.

44.9.1. Synopsis

```
lst
```

44.9.2. Description

LNet self-test helps site administrators confirm that Lustre Networking (LNet) has been properly installed and configured. The self-test also confirms that LNet and the network software and hardware underlying it are performing as expected.

Each LNet self-test runs in the context of a session. A node can be associated with only one session at a time, to ensure that the session has exclusive use of the nodes on which it is running. A session is create, controlled and monitored from a single node; this is referred to as the self-test console.

Any node may act as the self-test console. Nodes are named and allocated to a self-test session in groups. This allows all nodes in a group to be referenced by a single name.

Test configurations are built by describing and running test batches. A test batch is a named collection of tests, with each test composed of a number of individual point-to-point tests running in parallel. These individual point-to-point tests are instantiated according to the test type, source group, target group and distribution specified when the test is added to the test batch.

44.9.3. Modules

To run LNet self-test, load these modules: libcfs, lnet, lnet_selftest and any one of the klnds (ksocklnd, ko2iblnd...). To load all necessary modules, run `modprobe lnet_selftest`, which recursively loads the modules on which `lnet_selftest` depends.

There are two types of nodes for LNet self-test: the console node and test nodes. Both node types require all previously-specified modules to be loaded. (The userspace test node does not require these modules).

Test nodes can be in either kernel or in userspace. A console user can invite a kernel test node to join the test session by running `lst add_group NID`, but the user cannot actively add a userspace test node to the test session. However, the console user can passively accept a test node to the test session while the test node runs `lst client` to connect to the console.

44.9.4. Utilities

LNet self-test includes two user utilities, `lst` and `lstclient`.

`lst` is the user interface for the self-test console (run on the console node). It provides a list of commands to control the entire test system, such as create session, create test groups, etc.

`lstclient` is the userspace self-test program which is linked with userspace LNDs and LNet. A user can invoke `lstclient` to join a self-test session:

```
lstclient -sesid CONSOLE_NID group NAME
```

44.9.5. Example Script

This is a sample LNet self-test script which simulates the traffic pattern of a set of Lustre servers on a TCP network, accessed by Lustre clients on an IB network (connected via LNet routers), with half the clients reading and half the clients writing.

```
#!/bin/bash
export LST_SESSION=$$
lst new_session read/write
lst add_group servers 192.168.10.[8,10,12-16]@tcp
```

```
lst add_group readers 192.168.1.[1-253/2]@o2ib
lst add_group writers 192.168.1.[2-254/2]@o2ib
lst add_batch bulk_rw
lst add_test --batch bulk_rw --from readers --to servers      brw read check\
=simple size=1M
lst add_test --batch bulk_rw --from writers --to servers      brw write chec\
k=full size=4K
# start running
lst run bulk_rw
# display server stats for 30 seconds
lst stat servers & sleep 30; kill $!
# tear down
lst end_session
```

44.10. lustre_rmmod.sh

The `lustre_rmmod.sh` utility removes all Lustre and LNet modules (assuming no Lustre services are running). It is located in `/usr/bin`.

Note

The `lustre_rmmod.sh` utility does not work if Lustre modules are being used or if you have manually run the `lctl network up` command.

44.11. lustre_rsync

The `lustre_rsync` utility synchronizes (replicates) a Lustre file system to a target file system.

44.11.1. Synopsis

```
lustre_rsync --source|-s src --target|-t tgt
  --mdt|-m mdt [--user|-u userid]
  [--xattr|-x yes/no] [--verbose|-v]
  [--statuslog|-l log] [--dry-run] [--abort-on-err]
```

```
lustre_rsync --statuslog|-l log
```

```
lustre_rsync --statuslog|-l log --source|-s source
  --target|-t tgt --mdt|-m mdt
```

44.11.2. Description

The `lustre_rsync` utility is designed to synchronize (replicate) a Lustre file system (source) to another file system (target). The target can be a Lustre file system or any other type, and is a normal, usable file system. The synchronization operation is efficient and does not require directory walking, as `lustre_rsync` uses Lustre MDT changelogs to identify changes in the Lustre file system.

Before using `lustre_rsync`:

- A changelog user must be registered (see `lctl (8) changelog_register`)

- AND -

- Verify that the Lustre file system (source) and the replica file system (target) are identical before the changelog user is registered. If the file systems are discrepant, use a utility, e.g. regular rsync (not `lustre_rsync`) to make them identical.

44.11.3. Options

Option	Description
<code>--source=src</code>	The path to the root of the Lustre file system (source) which will be synchronized. This is a mandatory option if a valid status log created during a previous synchronization operation (<code>--statuslog</code>) is not specified.
<code>--target=tgt</code>	The path to the root where the source file system will be synchronized (target). This is a mandatory option if the status log created during a previous synchronization operation (<code>--statuslog</code>) is not specified. This option can be repeated if multiple synchronization targets are desired.
<code>--mdt=mdt</code>	The metadata device to be synchronized. A changelog user must be registered for this device. This is a mandatory option if a valid status log created during a previous synchronization operation (<code>--statuslog</code>) is not specified.
<code>--user=userid</code>	The changelog user ID for the specified MDT. To use <code>lustre_rsync</code> , the changelog user must be registered. For details, see the <code>changelog_register</code> parameter in the <code>lctl</code> man page. This is a mandatory option if a valid status log created during a previous synchronization operation (<code>--statuslog</code>) is not specified.
<code>--statuslog=log</code>	A log file to which synchronization status is saved. When <code>lustre_rsync</code> starts, the state of a previous replication is read from here. If the status log from a previous synchronization operation is specified, otherwise mandatory options like <code>--source</code> , <code>--target</code> and <code>--mdt</code> options may be skipped. By specifying options like <code>--source</code> , <code>--target</code> and/or <code>--mdt</code> in addition to the <code>--statuslog</code> option, parameters in the status log can be overridden. Command line options take precedence over options in the status log.
<code>--xattryes/no</code>	Specifies whether extended attributes (xattrs) are synchronized or not. The default is to synchronize extended attributes. NOTE: Disabling xattrs causes Lustre striping information not to be synchronized.
<code>--verbose</code>	Produces a verbose output.
<code>--dry-run</code>	Shows the output of <code>lustre_rsync</code> commands (<code>copy</code> , <code>mkdir</code> , etc.) on the target file system without actually executing them.

Option	Description
<code>--abort-on-err</code>	Shows the output of <code>lustre_rsync</code> commands (<code>copy</code> , <code>mkdir</code> , etc.) on the target file system without actually executing them.

44.11.4. Examples

Register a changelog user for an MDT (e.g., MDT `lustre-MDT0000`).

```
$ ssh
$ MDS lctl changelog_register \
    --device lustre-MDT0000 -n
c11
```

Synchronize/replicate a Lustre file system (`/mnt/lustre`) to a target file system (`/mnt/target`).

```
$ lustre_rsync --source=/mnt/lustre --target=/mnt/target \
    --mdt=lustre-MDT0000 --user=c11 \
    --statuslog replicate.log --verbose
Lustre filesystem: lustre
MDT device: lustre-MDT0000
Source: /mnt/lustre
Target: /mnt/target
Statuslog: sync.log
Changelog registration: c11
Starting changelog record: 0
Errors: 0
lustre_rsync took 1 seconds
Changelog records consumed: 22
```

After the file system undergoes changes, synchronize the changes with the target file system. Only the statuslog name needs to be specified, as it has all the parameters passed earlier.

```
$ lustre_rsync --statuslog replicate.log --verbose
Replicating Lustre filesystem: lustre
MDT device: lustre-MDT0000
Source: /mnt/lustre
Target: /mnt/target
Statuslog: replicate.log
Changelog registration: c11
Starting changelog record: 22
Errors: 0
lustre_rsync took 2 seconds
Changelog records consumed: 42
```

Synchronize a Lustre file system (`/mnt/lustre`) to two target file systems (`/mnt/target1` and `/mnt/target2`).

```
$ lustre_rsync --source=/mnt/lustre \
    --target=/mnt/target1 --target=/mnt/target2 \
    --mdt=lustre-MDT0000 --user=c11
    --statuslog replicate.log
```

44.11.5. See Also

Section 40.1, “`lfs`”

44.12. mkfs.lustre

The `mkfs.lustre` utility formats a disk for a Lustre service.

44.12.1. Synopsis

```
mkfs.lustre target_type [options] device
```

where `target_type` is one of the following:

Option	Description
<code>--ost</code>	Object storage target (OST)
<code>--mdt</code>	Metadata storage target (MDT)
<code>--network=net,...</code>	Network(s) to which to restrict this OST/MDT. This option can be repeated as necessary.
<code>--mgs</code>	Configuration management service (MGS), one per site. This service can be combined with one <code>--mdt</code> service by specifying both types.

44.12.2. Description

`mkfs.lustre` is used to format a disk device for use as part of a Lustre file system. After formatting, a disk can be mounted to start the Lustre service defined by this command.

When the file system is created, parameters can simply be added as a `--param` option to the `mkfs.lustre` command. See Section 13.12.1, “Setting Tunable Parameters with `mkfs.lustre`”.

Option	Description
<code>--backfstype=fstype</code>	Forces a particular format for the backing file system such as <code>ldiskfs</code> (the default) or <code>zfs</code> .
<code>--comment=comment</code>	Sets a user comment about this disk, ignored by the Lustre software.
<code>--device-size=#>KB</code>	Sets the device size for loop devices.
<code>--dryrun</code>	Only prints what would be done; it does not affect the disk.
<code>--servicenode=nid,...</code>	Sets the NID(s) of all service nodes, including primary and failover partner service nodes. The <code>--servicenode</code> option cannot be used with <code>--failnode</code> option. See Section 11.2, “Preparing a Lustre File System for Failover” for more details.
<code>--failnode=nid,...</code>	Sets the NID(s) of a failover service node for a primary server for a target. The <code>--failnode</code> option cannot be used with <code>--servicenode</code> option. See Section 11.2, “Preparing a Lustre File System for Failover” for more details. <p>Note</p> <p>When the <code>--failnode</code> option is used, certain restrictions apply (see Section 11.2, “Preparing a Lustre File System for Failover”).</p>
<code>--fsname=filesystem_name</code>	The Lustre file system of which this service/node will be a part. The default file system name is <code>lustre</code> .

Option	Description
	<p data-bbox="816 296 894 327">Note</p> <p data-bbox="816 365 1317 396">The file system name is limited to 8 characters.</p>
--index= <i>index_number</i>	Specifies the OST or MDT number (0...N). This allows mapping between the OSS and MDS node and the device on which the OST or MDT is located.
--mkfsoptions= <i>opts</i>	Formats options for the backing file system. For example, ext3 options could be set here.
--mountfsoptions= <i>opts</i>	<p data-bbox="769 594 1425 653">Sets the mount options used when the backing file system is mounted.</p> <p data-bbox="816 684 959 716">Warning</p> <p data-bbox="816 753 1382 909">Unlike earlier versions of <code>mkfs.lustre</code>, this version completely replaces the default mount options with those specified on the command line, and issues a warning on <code>stderr</code> if any default mount options are omitted.</p> <p data-bbox="769 940 1062 972">The defaults for <code>ldiskfs</code> are:</p> <p data-bbox="769 999 1425 1058">MGS/MDT: <code>errors=remount-ro,iopen_nopriv,user_xattr</code></p> <p data-bbox="769 1089 1357 1121">OST: <code>errors=remount-ro,extents,malloc</code></p> <div data-bbox="662 1121 1425 1167" style="background-color: #cccccc; padding: 2px;">Introduced in Lustre 2.5</div> <p data-bbox="769 1194 1105 1226">OST: <code>errors=remount-ro</code></p> <p data-bbox="769 1266 1295 1297">Use care when altering the default mount options.</p>
--network= <i>net</i> ,...	Network(s) to which to restrict this OST/MDT. This option can be repeated as necessary.
--mgsnode= <i>nid</i> ,...	Sets the NIDs of the MGS node, required for all targets other than the MGS.
--param <i>key=value</i>	Sets the permanent parameter <i>key</i> to value <i>value</i> . This option can be repeated as necessary. Typical options might include:
	<pre data-bbox="545 1598 987 1656">--param sys.timeout=40></pre>
	<pre data-bbox="545 1671 971 1730">--param lov.stripe_size=2M</pre>
	<pre data-bbox="545 1745 987 1803">param lov.stripecount=2</pre>
	<pre data-bbox="545 1818 1260 1877">--param failover.mode=failout</pre>

Option	Description
<code>--quiet</code>	Prints less information.
<code>--reformat</code>	Reformats an existing Lustre disk.
<code>--stripe-count-hint=stripes</code>	Used to optimize the MDT's inode size.
<code>--verbose</code>	Prints more information.

44.12.3. Examples

Creates a combined MGS and MDT for file system `testfs` on, e.g., node `cfs21`:

```
mkfs.lustre --fsname=testfs --mdt --mgs /dev/sda1
```

Creates an OST for file system `testfs` on any node (using the above MGS):

```
mkfs.lustre --fsname=testfs --mgsnode=cfs21@tcp0 --ost --index=0 /dev/sdb
```

Creates a standalone MGS on, e.g., node `cfs22`:

```
mkfs.lustre --mgs /dev/sda1
```

Creates an MDT for file system `myfs1` on any node (using the above MGS):

```
mkfs.lustre --fsname=myfs1 --mdt --mgsnode=cfs22@tcp0 /dev/sda2
```

44.12.4. See Also

- Section 44.12, “`mkfs.lustre`” `mkfs.lustre`,
- Section 44.13, “`mount.lustre`” `mount.lustre`,
- Section 40.1, “`lfs`” `lfs`

44.13. `mount.lustre`

The `mount.lustre` utility starts a Lustre client or target service.

44.13.1. Synopsis

```
mount -t lustre [-o options] device mountpoint
```

44.13.2. Description

The `mount.lustre` utility starts a Lustre client or target service. This program should not be called directly; rather, it is a helper program invoked through `mount(8)`, as shown above. Use the `umount` command to stop Lustre clients and targets.

There are two forms for the `device` option, depending on whether a client or a target service is started:

Option	Description
<code>mgsname:/fsname[/subdir]</code>	Mounts the Lustre file system named <code>fsname</code> (optionally starting at subdirectory <code>subdir</code> within

Option	Description
	the filesystem, if specified) on the client at the directory <i>mountpoint</i> , by contacting the Lustre Management Service at <i>mgsname</i> . The format for <i>mgsname</i> is defined below. A client file system can be listed in <i>fstab(5)</i> for automatic mount at boot time, is usable like any local file system, and provides a full POSIX standard-compliant interface.
<i>block_device</i>	Starts the target service defined by the <code>mkfs.lustre(8)</code> command on the physical disk <i>block_device</i> . The <i>block_device</i> may be specified using <code>-L label</code> to find the first block device with that label (e.g. <code>testfs-MDT0000</code>), or by UUID using the <code>-U uuid</code> option. Care should be taken if there is a device-level backup of the target filesystem on the same node, which would have a duplicate label and UUID if it has not been changed with <code>tune2fs(8)</code> or similar. The mounted target service filesystem mounted at <i>mountpoint</i> is only useful for <code>df(1)</code> operations and appears in <code>/proc/mounts</code> to show the device is in use.

44.13.3. Options

Option	Description
<code>mgsname=mgsnode[:mgsnode]</code>	<i>mgsname</i> is a colon-separated list of <i>mgsnode</i> names where the MGS service may run. Multiple <i>mgsnode</i> values can be specified if the MGS service is configured for HA failover and may be running on any one of the nodes.
<code>mgsnode=mgsnid[,mgsnid]</code>	Each <i>mgsnode</i> may specify a comma-separated list of NIDs, if there are different LNet interfaces for that <i>mgsnode</i> .
<code>mgssec=flavor</code>	Specifies the encryption flavor for the initial network RPC connection to the MGS. Non-security flavors are: <code>null</code> , <code>plain</code> , and <code>gssnull</code> , which respectively disable, or have no encryption or integrity features for testing purposes. Kerberos flavors are: <code>krb5n</code> , <code>krb5a</code> , <code>krb5i</code> , and <code>krb5p</code> . Shared-secret key flavors are: <code>skn</code> , <code>ska</code> , <code>ski</code> , and <code>skpi</code> , see the Chapter 29, <i>Configuring Shared-Secret Key (SSK) Security</i> for more details. The security flavor for client-to-server connections is specified in the filesystem configuration that the client fetches from the MGS.
<code>skpath=file/directory</code>	<div style="background-color: #cccccc; padding: 2px;">Introduced in Lustre 2.9</div> Path to a file or directory with the keyfile(s) to load for this mount command. Keys are inserted into the

Option	Description
	KEY_SPEC_SESSION_KEYRING keyring in the kernel with a description containing <code>lustre:</code> and a suffix which depends on whether the context of the mount command is for an MGS, MDT/OST, or client.
<code>exclude=ostlist</code>	Starts a client or MDT with a colon-separated list of known inactive OSTs that it will not try to connect to.

In addition to the standard mount(8) options, Lustre understands the following client-specific options:

Option	Description
<code>always_ping</code>	Introduced in Lustre 2.9 The client will periodically ping the server when it is idle, even if the server <code>ptlrpc</code> module is configured with the <code>suppress_pings</code> option. This allows clients to reliably use the filesystem even if they are not part of an external client health monitoring mechanism.
<code>flock</code>	Enables advisory file locking support between participating applications using the <code>flock(2)</code> system call. This causes file locking to be coherent across all client nodes also using this mount option. This is useful if applications need coherent userspace file locking across multiple client nodes, but also imposes communications overhead in order to maintain locking consistency between client nodes.
<code>localflock</code>	Enables client-local <code>flock(2)</code> support, using only client-local advisory file locking. This is faster than using the global <code>flock</code> option, and can be used for applications that depend on functioning <code>flock(2)</code> but run only on a single node. It has minimal overhead using only the Linux kernel's locks.
<code>noflock</code>	Disables <code>flock(2)</code> support entirely, and is the default option. Applications calling <code>flock(2)</code> get an <code>ENOSYS</code> error. It is up to the administrator to choose either the <code>localflock</code> or <code>flock</code> mount option based on their requirements. It is possible to mount clients with different options, and only those mounted with <code>flock</code> will be coherent amongst each other.
<code>lazystatfs</code>	Allows <code>statfs(2)</code> (as used by <code>df(1)</code> and <code>lfs-df(1)</code>) to return even if some OST or MDT is unresponsive or has been temporarily or permanently disabled in the configuration. This avoids blocking until all of the targets are available. This is the default behavior since Lustre 2.9.0.

Option	Description
nolazystatfs	Requires that <code>statfs(2)</code> block until all OSTs and MDTs are available and have returned space usage.
user_xattr	Enables get/set of extended attributes by regular users in the <code>user.*</code> namespace. See the <code>attr(5)</code> manual page for more details.
nouser_xattr	Disables use of extended attributes in the <code>user.*</code> namespace by regular users. Root and system processes can still use extended attributes.
verbose	Enable extra mount/umount console messages.
noverbose	Disable mount/umount console messages.
user_fid2path	Enable FID-to-path translation by regular users. Note This option allows a potential security hole because it allows regular users direct access to a file by its Lustre File ID. This bypasses POSIX path-based permission checks, and could allow the user to access a file in a directory that they do not have access to. Regular POSIX file mode and ACL permission checks are still performed on the file itself, so users cannot access a file to which they have no permission.
nouser_fid2path	Disable FID to path translation by regular users. Root and processes with <code>CAP_DAC_READ_SEARCH</code> can still perform FID to path translation.

In addition to the standard mount options and backing disk type (e.g. `ldiskfs`) options, Lustre understands the following server-specific mount options:

Option	Description
nosvc	Starts the MGC (and MGS, if co-located) for a target service, not the actual service.
nomgs	Starts only the MDT (with a co-located MGS), without starting the MGS.
abort_recov	Aborts client recovery on that server and starts the target service immediately.
max_sectors_kb= <i>KB</i>	Introduced in Lustre 2.10 Sets the block device parameter <code>max_sectors_kb</code> limit for the MDT or OST target being mounted to specified maximum number of kilobytes. When <code>max_sectors_kb</code> isn't specified as a mount option, it will automatically be set to the <code>max_hw_sectors_kb</code> (up to a maximum of 16MiB) for that block device. This

Option	Description
	default behavior is suited for most users. When <code>max_sectors_kb=0</code> is used, the current value for this tunable will be kept.
<code>md_stripe_cache_size</code>	Sets the stripe cache size for server-side disk with a striped RAID configuration.
<code>recovery_time_soft=timeout</code>	<p>Allows <code>timeout</code> seconds for clients to reconnect for recovery after a server crash. This timeout is incrementally extended if it is about to expire and the server is still handling new connections from recoverable clients.</p> <p>The default soft recovery timeout is 3 times the value of the Lustre timeout parameter (see Section 39.5.2, “Setting Static Timeouts”). The default Lustre timeout is 100 seconds, which would make the soft recovery timeout default to 300 seconds (5 minutes). The soft recovery timeout is set at mount time and will not change if the Lustre timeout is changed after mount time.</p>
<code>recovery_time_hard=timeout</code>	<p>The server is allowed to incrementally extend its timeout up to a hard maximum of <code>timeout</code> seconds.</p> <p>The default hard recovery timeout is 9 times the value of the Lustre timeout parameter (see Section 39.5.2, “Setting Static Timeouts”). The default Lustre timeout is 100 seconds, which would make the hard recovery timeout default to 900 seconds (15 minutes). The hard recovery timeout is set at mount time and will not change if the Lustre timeout is changed after mount time.</p>
<code>noscrub</code>	Typically the MDT will detect restoration from a file-level backup during mount. This mount option prevents the OI Scrub from starting automatically when the MDT is mounted. Manually starting LFSCK after mounting provides finer control over the starting conditions. This mount option also prevents OI scrub from occurring automatically when OI inconsistency is detected (see Section 36.4.4.2, “Auto scrub”).

44.13.4. Examples

Starts a client for the Lustre file system `chipfs` at mount point `/mnt/chip`. The Management Service is running on a node reachable from this client via the `cfs21@tcp0` NID.

```
mount -t lustre cfs21@tcp0:/chipfs /mnt/chip
```

Introduced in Lustre 2.9

Similar to the above example, but mounting a subdirectory under `chipfs` as a fileset.

```
mount -t lustre cfs21@tcp0:/chipfs/v1_0 /mnt/chipv1_0
```

Starts the Lustre metadata target service from /dev/sda1 on mount point /mnt/test/mdt.

```
mount -t lustre /dev/sda1 /mnt/test/mdt
```

Starts the testfs-MDT0000 service (using the disk label), but aborts the recovery process.

```
mount -t lustre -L testfs-MDT0000 -o abort_recov /mnt/test/mdt
```

44.13.5. See Also

- Section 44.12, “mkfs.lustre”
- Section 44.15, “tunefs.lustre”
- Section 44.2, “lctl”
- Section 40.1, “lfs”

44.14. routerstat

The routerstat utility prints Lustre router statistics.

44.14.1. Synopsis

```
routerstat [interval]
```

44.14.2. Description

The routerstat utility displays LNet router statistics. If no *interval* is specified, then statistics are sampled and printed only one time. Otherwise, statistics are sampled and printed at the specified *interval* (in seconds).

44.14.3. Output

The routerstat output includes the following fields:

Output	Description
M	Number of messages currently being processed by LNet (The maximum number of messages ever processed by LNet concurrently)
E	Number of LNet errors
S	Total size (length) of messages sent in bytes/ Number of messages sent
R	Total size (length) of messages received in bytes/ Number of messages received
F	Total size (length) of messages routed in bytes/ Number of messages routed
D	Total size (length) of messages dropped in bytes/ Number of messages dropped

When an *interval* is specified, additional lines of statistics are printed including the following fields:

Output	Description
M	Number of messages currently being processed by LNet (The maximum number of messages ever processed by LNet concurrently)
E	Number of LNet errors per second
S	Rate of data sent in Mbytes per second/ Count of messages sent per second
R	Rate of data received in Mbytes per second/ Count of messages received per second
F	Rate of data routed in Mbytes per second/ Count of messages routed per second
D	Rate of data dropped in Mbytes per second/ Count of messages dropped per second

44.14.4. Example

```
# routerstat 1
M 0(13) E 0 S 117379184/4250 R 878480/4356 F 0/0 D 0/0
M 0( 13) E 0 S 7.00/ 7 R 0.00/ 14 F 0.00/ 0 D 0.00/0
M 0( 13) E 0 S 7.00/ 7 R 0.00/ 14 F 0.00/ 0 D 0.00/0
M 0( 13) E 0 S 8.00/ 8 R 0.00/ 16 F 0.00/ 0 D 0.00/0
M 0( 13) E 0 S 7.00/ 7 R 0.00/ 14 F 0.00/ 0 D 0.00/0
M 0( 13) E 0 S 7.00/ 7 R 0.00/ 14 F 0.00/ 0 D 0.00/0
M 0( 13) E 0 S 7.00/ 7 R 0.00/ 14 F 0.00/ 0 D 0.00/0
M 0( 13) E 0 S 7.00/ 7 R 0.00/ 14 F 0.00/ 0 D 0.00/0
M 0( 13) E 0 S 8.00/ 8 R 0.00/ 16 F 0.00/ 0 D 0.00/0
M 0( 13) E 0 S 7.00/ 7 R 0.00/ 14 F 0.00/ 0 D 0.00/0
...
```

44.14.5. Files

The `routerstat` utility extracts statistics data from the `LNet stats` parameter.

44.15. tunefs.lustre

The `tunefs.lustre` utility modifies configuration information on a Lustre target disk.

44.15.1. Synopsis

```
tunefs.lustre [options] /dev/device
```

44.15.2. Description

`tunefs.lustre` is used to modify configuration information on a Lustre target disk. This does not reformat the disk or erase the target information, but incorrectly modifying the configuration information may result in an unusable file system.

Caution

Changes made here affect a file system only when the target is mounted the next time.

With `tunefs.lustre`, parameters are "additive" -- new parameters are specified in addition to old parameters, they do not replace them. To erase all previously-specified `tunefs.lustre` parameters and use only newly-specified parameters, run:

```
$ tunefs.lustre --erase-params --param=new_parameters
```

The `tunefs.lustre` command can be used to set any parameter settable in a `/proc/fs/lustre` file and that has its own OBD device. The parameter names generally take the form `{obd/filename}.obdtype.parameter=value`. For example:

```
$ tunefs.lustre --param mdt.identity_upcall=NONE /dev/sda1
```

44.15.3. Options

The `tunefs.lustre` options are listed and explained below.

Option	Description
<code>--comment=comment</code>	Sets a user comment about this disk, ignored by Lustre.
<code>--dryrun</code>	Only prints what would be done; does not affect the disk.
<code>--erase-params</code>	Removes all previous parameter information.
<code>--servicenode=nid,...</code>	Sets the NID(s) of all service nodes, including primary and failover partner service nodes. The <code>--servicenode</code> option cannot be used with <code>--failnode</code> option. See Section 11.2, "Preparing a Lustre File System for Failover" for more details.
<code>--failnode=nid,...</code>	Sets the NID(s) of a failover service node for a primary server for a target. The <code>--failnode</code> option cannot be used with <code>--servicenode</code> option. See Section 11.2, "Preparing a Lustre File System for Failover" for more details. <p>Note</p> <p>When the <code>--failnode</code> option is used, certain restrictions apply (see Section 11.2, "Preparing a Lustre File System for Failover").</p>
<code>--fsname=filesystem_name</code>	The Lustre file system of which this service will be a part. The default file system name is <code>lustre</code> .
<code>--index=index</code>	Forces a particular OST or MDT index.
<code>--mountfsoptions=options</code>	Sets the mount options used when the backing file system is mounted.

Option	Description
	<p>Warning</p> <p>Unlike earlier versions of <code>tunefs.lustre</code>, this version completely replaces the existing mount options with those specified on the command line, and issues a warning on <code>stderr</code> if any default mount options are omitted.</p> <p>The defaults for <code>ldiskfs</code> are:</p> <pre>MGS/MDT: errors=remount-ro,iopen_nopriv,user_xattr OST: errors=remount-ro,extents,malloc</pre> <p>Introduced in Lustre 2.5</p> <pre>OST: errors=remount-ro</pre> <p>Do not alter the default mount options unless you know what you are doing.</p>
--network= <i>net</i> ,...	Network(s) to which to restrict this OST/MDT. This option can be repeated as necessary.
--mgs	Adds a configuration management service to this target.
--msgnode= <i>nid</i> ,...	Sets the NID(s) of the MGS node; required for all targets other than the MGS.
--nomgs	Removes a configuration management service to this target.
--quiet	Prints less information.
--verbose	Prints more information.
--writeconf	<p>Erases all configuration logs for the file system to which this MDT belongs, and regenerates them. This is dangerous operation. All clients must be unmounted and servers for this file system should be stopped. All targets (OSTs/MDTs) must then be restarted to regenerate the logs. No clients should be started until all targets have restarted.</p> <p>The correct order of operations is:</p> <ol style="list-style-type: none"> 1. Unmount all clients on the file system 2. Unmount the MDT and all OSTs on the file system 3. Run <code>tunefs.lustre --writeconf device</code> on every server

Option	Description
	4. Mount the MDT and OSTs
	5. Mount the clients

44.15.4. Examples

Change the MGS's NID address. (This should be done on each target disk, since they should all contact the same MGS.)

```
tunefs.lustre --erase-param --mgsnode=new_nid --writeconf /dev/sda
```

Add a failover NID location for this target.

```
tunefs.lustre --param="failover.node=192.168.0.13@tcp0" /dev/sda
```

44.15.5. See Also

- Section 44.12, “mkfs.lustre”
- Section 44.13, “mount.lustre”
- Section 44.2, “lctl”
- Section 40.1, “lfs”

44.16. Additional System Configuration Utilities

This section describes additional system configuration utilities for Lustre.

44.16.1. More Statistics for Application Profiling

Lustre includes per-client and improved MDT statistics:

- Per-client statistics tracked on the servers

Each MDS and OSS now tracks LDLM and operations statistics for every connected client, for comparisons and simpler collection of distributed job statistics.

```
{mds,obdfilter}.*.exports
```

- Improved MDT statistics

More detailed MDT operations statistics are collected for better profiling.

```
mdt.*.md_stats
```

44.16.2. Testing / Debugging Utilities

Lustre offers the following test and debugging utilities.

44.16.2.1. lr_reader

The `lr_reader` utility translates the content of the `last_rcvd` and `reply_data` files into human-readable form.

The following utilities are part of the Lustre I/O kit. For more information, see Chapter 33, *Benchmarking Lustre File System Performance (Lustre I/O Kit)*.

44.16.2.2. sgpdd-survey

The `sgpdd-survey` utility tests 'bare metal' performance, bypassing as much of the kernel as possible. The `sgpdd-survey` tool does not require Lustre, but it does require the `sgp_dd` package.

Caution

The `sgpdd-survey` utility erases all data on the device.

44.16.2.3. obdfilter-survey

The `obdfilter-survey` utility is a shell script that tests performance of isolated OSTs, the network via echo clients, and an end-to-end test.

44.16.2.4. ior-survey

The `ior-survey` utility is a script used to run the IOR benchmark. Lustre includes IOR version 2.8.6.

44.16.2.5. ost-survey

The `ost-survey` utility is an OST performance survey that tests client-to-disk performance of the individual OSTs in a Lustre file system.

44.16.2.6. stats-collect

The `stats-collect` utility contains scripts used to collect application profiling information from Lustre clients and servers.

Introduced in Lustre 2.9

44.16.3. Fileset Feature

With the fileset feature, Lustre now provides subdirectory mount support. Subdirectory mounts, also referred to as filesets, allow a client to mount a child directory of a parent filesystem, thereby limiting the filesystem namespace visibility on a specific client. A common use case is for a client to use a subdirectory mount when there is a desire to limit the visibility of the entire filesystem namespace to aid in the prevention of accidental file deletions outside of the subdirectory mount.

It is important to note that invocation of the subdirectory mount is voluntary by the client and does not prevent access to files that are visible in multiple subdirectory mounts via hard links. Furthermore, it does not prevent the client from subsequently mounting the whole file system without a subdirectory being specified.

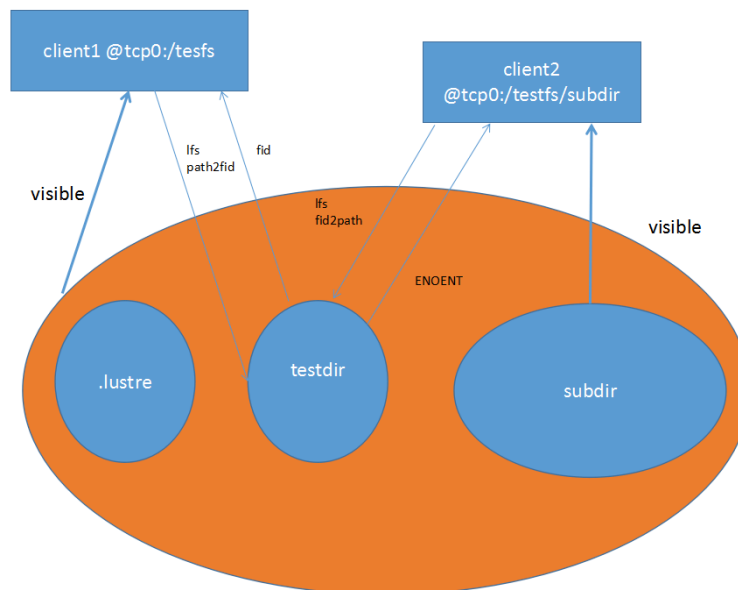
Figure 44.1. Lustre fileset

44.16.3.1. Examples

The following example will mount the `chipfs` filesystem on `client1` and create a subdirectory `v1_1` within that filesystem. `Client2` will then mount only the `v1_1` subdirectory as a fileset, thereby limiting access to anything else in the `chipfs` filesystem from `client2`.

```
client1# mount -t lustre mgs@tcp:/chipfs /mnt/chip
client1# mkdir /mnt/chip/v1_1

client2# mount -t lustre mgs@tcp:/chipfs/v1_1 /mnt/chipv1_1
```

You can check the created mounts in `/etc/mtab`. It should look like the following:

```
client1
mds@tcp0:/chipfs/ /mnt/chip lustre rw          0          0

client2
mds@tcp0:/chipfs/v1_1 /mnt/chipv1_1 lustre rw          0          0
```

Create a directory under the `/mnt/chip` mount, and get its FID

```
client1# mkdir /mnt/chip/v1_2
client1# lfs path2fid /mnt/chip/v1_2
[0x200000400:0x2:0x0]
```

If you try resolve the FID of the `/mnt/chip/v1_2` path (as created in the example above) on `client2`, an error will be returned as the FID can not be resolved on `client2` since it is not part of the mounted fileset on that client. Recall that the fileset on `client2` mounted the `v1_1` subdirectory beneath the top level `chipfs` filesystem.

```
client2# lfs fid2path /mnt/chip/v1_2 [0x200000400:0x2:0x0]
```

```
fid2path: error on FID [0x200000400:0x2:0x0]: No such file or directory

Subdirectory mounts do not have the .lustre pseudo directory, which prevents clients from opening
or accessing files only by FID.

client1# ls /mnt/chipfs/.lustre
      fid  lost+found

client2# ls /mnt/chipv1_1/.lustre
ls: cannot access /mnt/chipv1_1/.lustre: No such file or directory
```

Chapter 45. LNet Configuration C-API

This section describes the LNet Configuration C-API library. This API allows the developer to programmatically configure LNet. It provides APIs to add, delete and show LNet configuration items listed below. The API utilizes IOCTL to communicate with the kernel. Changes take effect immediately and do not require restarting LNet. API calls are synchronous

- Configuring LNet
- Enabling/Disabling routing
- Adding/removing/showing Routes
- Adding/removing/showing Networks
- Configuring Router Buffer Pools

45.1. General API Information

45.1.1. API Return Code

LUSTRE_CFG_RC_NO_ERR	0
LUSTRE_CFG_RC_BAD_PARAM	-1
LUSTRE_CFG_RC_MISSING_PARAM	-2
LUSTRE_CFG_RC_OUT_OF_RANGE_PARAM	-3
LUSTRE_CFG_RC_OUT_OF_MEM	-4
LUSTRE_CFG_RC_GENERIC_ERR	-5

45.1.2. API Common Input Parameters

All APIs take as input a sequence number. This is a number that's assigned by the caller of the API, and is returned in the YAML error return block. It is used to associate the request with the response. It is especially useful when configuring via the YAML interface, since typically the YAML interface is used to configure multiple items. In the return Error block, it is desired to know which items were configured properly and which were not configured properly. The sequence number achieves this purpose.

45.1.3. API Common Output Parameters

45.1.3.1. Internal YAML Representation (cYAML)

Once a YAML block is parsed it needs to be stored structurally in order to facilitate passing it to different functions, querying it and printing it. Also it is required to be able to build this internal representation from data returned from the kernel and return it to the caller, which can query and print it. This structure representation is used for the Error and Show API Out parameters. For this YAML is internally represented via this structure:

```
typedef enum {
    EN_YAML_TYPE_FALSE = 0,
    EN_YAML_TYPE_TRUE,
    EN_YAML_TYPE_NULL,
```

```
    EN_YAML_TYPE_NUMBER,
    EN_YAML_TYPE_STRING,
    EN_YAML_TYPE_ARRAY,
    EN_YAML_TYPE_OBJECT
} cYAML_object_type_t;

typedef struct cYAML {
    /* next/prev allow you to walk array/object chains. */
    struct cYAML *cy_next, *cy_prev;
    /* An array or object item will have a child pointer pointing
       to a chain of the items in the array/object. */
    struct cYAML *cy_child;
    /* The type of the item, as above. */
    cYAML_object_type_t cy_type;
    /* The item's string, if type==EN_YAML_TYPE_STRING */
    char *cy_valuestring;
    /* The item's number, if type==EN_YAML_TYPE_NUMBER */
    int cy_valueint;
    /* The item's number, if type==EN_YAML_TYPE_NUMBER */
    double cy_valuedouble;
    /* The item's name string, if this item is the child of,
       or is in the list of subitems of an object. */
    char *cy_string;
    /* user data which might need to be tracked per object */
    void *cy_user_data;
} cYAML;
```

45.1.3.2. Error Block

All APIs return a cYAML error block. This error block has the following format, when it's printed out. All configuration errors shall be represented in a YAML sequence

```
<cmd>:
- <entity>:
  errno: <error number>
  seqno: <sequence number>
  descr: <error description>
```

Example:

```
add:
- route
  errno: -2
  seqno: 1
  descr: Missing mandatory parameter(s) - network
```

45.1.3.3. Show Block

All Show APIs return a cYAML show block. This show block represents the information requested in YAML format. Each configuration item has its own YAML syntax. The YAML syntax of all supported configuration items is described later in this document. Below is an example of a show block:

```
net:
- nid: 192.168.206.130@tcp4
  status: up
```

```
interfaces:
  0: eth0
tunables:
  peer_timeout: 10
  peer_credits: 8
  peer_buffer_credits: 30
  credits: 40
```

45.2. The LNet Configuration C-API

45.2.1. Configuring LNet

```
/*
 * lustre_lnet_config_ni_system
 *   Initialize/Uninitialize the LNet NI system.
 *
 *   up - whether to init or uninit the system
 *   load_ni_from_mod - load NI from mod params.
 *   seq_no - sequence number of the request
 *   err_rc - [OUT] struct cYAML tree describing the error. Freed by
 *           caller
 */
int lustre_lnet_config_ni_system(bool up, bool load_ni_from_mod,
                                int seq_no, struct cYAML **err_rc);
```

IOCTL to Kernel:

IOC_LIBCFS_CONFIGURE or IOC_LIBCFS_UNCONFIGURE

Description:

Configuring LNet

Initialize LNet internals and load any networks specified in the module parameter if `load_ni_from_mod` is set. Otherwise do not load any network interfaces.

Unconfiguring LNet

Bring down LNet and clean up network interfaces, routes and all LNet internals.

Return Value

0: if success

-errno: if failure

45.2.2. Enabling and Disabling Routing

```
/*
 * lustre_lnet_enable_routing
```

```

*   Send down an IOCTL to enable or disable routing
*
*   enable - 1 to enable routing, 0 to disable routing
*   seq_no - sequence number of the request
*   err_rc - [OUT] cYAML tree describing the error. Freed by caller
*/
extern int lustre_lnet_enable_routing(int enable,
                                     int seq_no,
                                     cYAML **err_rc);

```

IOCTL to Kernel:

IOC_LIBCFS_ENABLE_RTR

Description:

Enabling Routing

The router buffer pools are allocated using the default values. Internally the node is then flagged as a Router node. The node can be used as a router from this point on.

Disabling Routing

The unused router buffer pools are freed. Buffers currently in use are not freed until they are returned to the unused list. Internally the node routing flag is turned off. Any subsequent messages not destined to this node are dropped.

Enabling Routing on an already enabled node, or vice versa

In both these cases the LNet Kernel module ignores this request.

Return Value

-ENOMEM: if there is no memory to allocate buffer pools

0: if success

45.2.3. Adding Routes

```

/*
* lustre_lnet_config_route
*   Send down an IOCTL to the kernel to configure the route
*
*   nw - network
*   gw - gateway
*   hops - number of hops passed down by the user
*   prio - priority of the route
*   err_rc - [OUT] cYAML tree describing the error. Freed by caller
*/
extern int lustre_lnet_config_route(char *nw, char *gw,
                                    int hops, int prio,
                                    int seq_no,
                                    cYAML **err_rc);

```

IOCTL to Kernel:

IOC_LIBCFS_ADD_ROUTE**Description:**

The LNet Kernel module adds this route to the list of existing routes, if one doesn't already exist. If the hops parameter is not specified then the hop count is set to "undefined"(-1). If the priority parameter is not specified then the priority is set to 0. All routes with the same hop and priority are used in round robin. Routes with lower number of hops and/or higher priority are preferred. 0 is the highest priority. "Undefined" hops (-1) is treated as 1 during route selection.

If a route already exists the request to add the same route is ignored.

Return Value

- EINVAL: if the network of the route is local
- ENOMEM: if there is no memory
- EHOSTUNREACH: if the host is not on a local network
- 0: if success

45.2.4. Deleting Routes

```
/*
 * lustre_lnet_del_route
 *   Send down an IOCTL to the kernel to delete a route
 *
 *   nw - network
 *   gw - gateway
 */
extern int lustre_lnet_del_route(char *nw, char *gw,
                                int seq_no,
                                cYAML **err_rc);
```

IOCTL to Kernel:**IOC_LIBCFS_DEL_ROUTE****Description:**

LNet will remove the route which matches the network and gateway passed in. If no route matches, then the operation fails with an appropriate error number.

Return Value

- ENOENT: if the entry being deleted doesn't exist
- 0: if success

45.2.5. Showing Routes

```
/*
 * lustre_lnet_show_route
```

```
*   Send down an IOCTL to the kernel to show routes
*   This function will get one route at a time and filter according to
*   provided parameters. If no filter is provided then it will dump all
*   routes that are in the system.
*
*   nw - network. Optional. Used to filter output
*   gw - gateway. Optional. Used to filter ouptut
*   hops - number of hops passed down by the user
*         Optional. Used to filter output.
*   prio - priority of the route. Optional. Used to filter output.
*   detail - flag to indicate whether detail output is required
*   show_rc - [OUT] The show output in YAML. Must be freed by caller.
*   err_rc - [OUT] cYAML tree describing the error. Freed by caller
*/
extern int lustre_lnet_show_route(char *nw, char *gw,
                                int hops, int prio, int detail,
                                int seq_no,
                                cYAML **show_rc,
                                cYAML **err_rc);
```

IOCTL to Kernel:

IOC_LIBCFS_GET_ROUTE

Description:

The routes are fetched from the kernel one by one and packed in a cYAML block, after filtering according to the parameters passed in. The cYAML block is then returned to the caller of the API.

An example with the detail parameter set to 1

```
route:
  net: tcp5
  gateway: 192.168.205.130@tcp
  hop: 1.000000
  priority: 0.000000
  state: up
```

An Example with the detail parameter set to 0

```
route:
  net: tcp5
  gateway: 192.168.205.130@tcp
```

Return Value

-ENOMEM: If no memory

0: if success

45.2.6. Adding a Network Interface

```
/*
 * lustre_lnet_config_net
 *   Send down an IOCTL to configure a network.
```

```
*
* net - the network name
* intf - the interface of the network of the form net_name(intf)
* peer_to - peer timeout
* peer_cr - peer credit
* peer_buf_cr - peer buffer credits
* - the above are LND tunable parameters and are optional
* credits - network interface credits
* smp - cpu affinity
* err_rc - [OUT] cYAML tree describing the error. Freed by caller
*/
extern int lustre_lnet_config_net(char *net,
                                char *intf,
                                int peer_to,
                                int peer_cr,
                                int peer_buf_cr,
                                int credits,
                                char *smp,
                                int seq_no,
                                cYAML **err_rc);
```

IOCTL to Kernel:

IOC_LIBCFS_ADD_NET

Description:

A new network is added and initialized. This has the same effect as configuring a network from the module parameters. The API allows the specification of network parameters such as the peer timeout, peer credits, peer buffer credits and credits. The CPU affinity of the network interface being added can also be specified. These parameters become network specific under Dynamic LNet Configuration (DLC), as opposed to being per LND as it was previously.

If an already existing network is added the request is ignored.

Return Value

-EINVAL: if the network passed in is not recognized.

-ENOMEM: if no memory

0: success

45.2.7. Deleting a Network Interface

```
/*
* lustre_lnet_del_net
* Send down an IOCTL to delete a network.
*
* nw - network to delete.
* err_rc - [OUT] cYAML tree describing the error. Freed by caller
*/
extern int lustre_lnet_del_net(char *nw,
                              int seq_no,
```

```
cYAML **err_rc);
```

IOCTL to Kernel:

```
IOC_LIBCFS_DEL_NET
```

Description:

The network interface specified is deleted. All resources associated with this network interface are freed. All routes going over that Network Interface are cleaned up.

If a non-existent network is deleted then the call returns -EINVAL.

Return Value

-EINVAL: if the request references a non-existent network.

0: success

45.2.8. Showing Network Interfaces

```
/*
 * lustre_lnet_show_net
 *   Send down an IOCTL to show networks.
 *   This function will use the nw parameter to filter the output.  If it's
 *   not provided then all networks are listed.
 *
 *   nw - network to show.  Optional.  Used to filter output.
 *   detail - flag to indicate if we require detail output.
 *   show_rc - [OUT] The show output in YAML.  Must be freed by caller.
 *   err_rc - [OUT] cYAML tree describing the error.  Freed by caller
 */
extern int lustre_lnet_show_net(char *nw, int detail,
                               int seq_no,
                               cYAML **show_rc,
                               cYAML **err_rc);
```

IOCTL to Kernel:

```
IOC_LIBCFS_GET_NET
```

Description:

The network interfaces are queried one at a time from the kernel and packed in a cYAML block, after filtering on the network (EX: tcp). If the detail field is set to 1, then the tunable section of the show block is included in the return.

An example of the detailed output

```
net:
  nid: 192.168.206.130@tcp4
  status: up
  interfaces:
    intf-0: eth0
  tunables:
    peer_timeout: 10
```

```
peer_credits: 8
peer_buffer_credits: 30
credits: 40
```

An example of none detailed output

```
net:
  nid: 192.168.206.130@tcp4
  status: up
  interfaces:
    intf-0: eth0
```

Return Value

-ENOMEM: if no memory to allocate the error or show blocks.

0: success

45.2.9. Adjusting Router Buffer Pools

```
/*
 * lustre_lnet_config_buf
 * Send down an IOCTL to configure buffer sizes. A value of 0 means
 * default that particular buffer to default size. A value of -1 means
 * leave the value of the buffer unchanged.
 *
 * tiny - tiny buffers
 * small - small buffers
 * large - large buffers.
 * err_rc - [OUT] cYAML tree describing the error. Freed by caller
 */
extern int lustre_lnet_config_buf(int tiny,
                                  int small,
                                  int large,
                                  int seq_no,
                                  cYAML **err_rc);
```

IOCTL to Kernel:

IOC_LIBCFS_ADD_BUF

Description:

This API is used to configure the tiny, small and large router buffers dynamically. These buffers are used to buffer messages which are being routed to other nodes. The minimum value of these buffers per CPT are:

```
#define LNET_NRB_TINY_MIN      512
#define LNET_NRB_SMALL_MIN    4096
#define LNET_NRB_LARGE_MIN    256
```

The default values of these buffers are:

```
#define LNET_NRB_TINY          (LNET_NRB_TINY_MIN * 4)
#define LNET_NRB_SMALL        (LNET_NRB_SMALL_MIN * 4)
#define LNET_NRB_LARGE        (LNET_NRB_LARGE_MIN * 4)
```

These default value is divided evenly across all CPTs. However, each CPT can only go as low as the minimum.

Multiple calls to this API with the same values has no effect

Return Value

-ENOMEM: if no memory to allocate buffer pools.

0: success

45.2.10. Showing Routing information

```

/*
 * lustre_lnet_show_routing
 *   Send down an IOCTL to dump buffers and routing status
 *   This function is used to dump buffers for all CPU partitions.
 *
 *   show_rc - [OUT] The show output in YAML. Must be freed by caller.
 *   err_rc - [OUT] struct cYAML tree describing the error. Freed by caller
 */
extern int lustre_lnet_show_routing(int seq_no, struct cYAML **show_rc,
                                   struct cYAML **err_rc);

```

IOCTL to Kernel:

IOC_LIBCFS_GET_BUF

Description:

This API returns a cYAML block describing the values of each of the following per CPT:

1. The number of pages per buffer. This is a constant.
2. The number of allocated buffers. This is a constant.
3. The number of buffer credits . This is a real-time value of the number of buffer credits currently available. If this value is negative, that indicates the number of queued messages.
4. The lowest number of credits ever reached in the system. This is historical data.

The show block also returns the status of routing, whether enabled, or disabled.

An exmaple YAML block

```

routing:
  - cpt[0]:
    tiny:
      npages: 0
      nbuffers: 2048
      credits: 2048
      mincredits: 2048
    small:
      npages: 1
      nbuffers: 16384

```

```
        credits: 16384
        mincredits: 16384
    large:
        npages: 256
        nbuffers: 1024
        credits: 1024
        mincredits: 1024
    - enable: 1
```

Return Value

-ENOMEM: if no memory to allocate the show or error block.

0: success

45.2.11. Showing LNet Traffic Statistics

```
/*
 * lustre_lnet_show_stats
 * Shows internal LNet statistics. This is useful to display the
 * current LNet activity, such as number of messages route, etc
 *
 * seq_no - sequence number of the command
 * show_rc - YAML structure of the resultant show
 * err_rc - YAML structure of the resultant return code.
 */
extern int lustre_lnet_show_stats(int seq_no, cYAML **show_rc,
                                  cYAML **err_rc);
```

IOCTL to Kernel:

IOC_LIBCFS_GET_LNET_STATS

Description:

This API returns a cYAML block describing the LNet traffic statistics. Statistics are continuously incremented by LNet while it's alive. This API returns the statistics at the time of the API call. The statistics include the following

1. Number of messages allocated
2. Maximum number of messages in the system
3. Errors allocating or sending messages
4. Cumulative number of messages sent
5. Cumulative number of messages received
6. Cumulative number of messages routed
7. Cumulative number of messages dropped
8. Cumulative number of bytes sent
9. Cumulative number of bytes received

10.Cumulative number of bytes routed

11.Cumulative number of bytes dropped

An example YAML block

```
statistics:
  msgs_alloc: 0
  msgs_max: 0
  errors: 0
  send_count: 0
  recv_count: 0
  route_count: 0
  drop_count: 0
  send_length: 0
  recv_length: 0
  route_length: 0
  drop_length: 0
```

Return Value

-ENOMEM: if no memory to allocate the show or error block.

0: success

45.2.12. Adding/Deleting/Showing Parameters through a YAML Block

```
/*
 * lustre_yaml_config
 *   Parses the provided YAML file and then calls the specific APIs
 *   to configure the entities identified in the file
 *
 *   f - YAML file
 *   err_rc - [OUT] cYAML tree describing the error. Freed by caller
 */
extern int lustre_yaml_config(char *f, cYAML **err_rc);

/*
 * lustre_yaml_del
 *   Parses the provided YAML file and then calls the specific APIs
 *   to delete the entities identified in the file
 *
 *   f - YAML file
 *   err_rc - [OUT] cYAML tree describing the error. Freed by caller
 */
extern int lustre_yaml_del(char *f, cYAML **err_rc);

/*
 * lustre_yaml_show
 *   Parses the provided YAML file and then calls the specific APIs
 *   to show the entities identified in the file
 *
 */
```



```
* f - YAML file
* show_rc - [OUT] The show output in YAML. Must be freed by caller.
* err_rc - [OUT] cYAML tree describing the error. Freed by caller
*/
extern int lustre_yaml_show(char *f,
                             cYAML **show_rc,
                             cYAML **err_rc);
```

IOCTL to Kernel:

Depends on the entity being configured

Description:

These APIs add/remove/show the parameters specified in the YAML file respectively. The entities don't have to be uniform. Multiple different entities can be added/removed/showed in one YAML block.

An example YAML block

```
---
net:
  - nid: 192.168.206.132@tcp
    status: up
    interfaces:
      0: eth3
    tunables:
      peer_timeout: 180
      peer_credits: 8
      peer_buffer_credits: 0
      credits: 256
      SMP: "[0]"
route:
  - net: tcp6
    gateway: 192.168.29.1@tcp
    hop: 4
    detail: 1
    seq_no: 3
  - net: tcp7
    gateway: 192.168.28.1@tcp
    hop: 9
    detail: 1
    seq_no: 4
buffer:
  - tiny: 1024
    small: 2000
    large: 512
...
```

Return Value

Return value will correspond to the return value of the API that will be called to operate on the configuration item, as described in previous sections

45.2.13. Adding a route code example

```

int main(int argc, char **argv)
{
    char *network = NULL, *gateway = NULL;
    long int hop = -1, prio = -1;
    struct cYAML *err_rc = NULL;
    int rc, opt;
    optind = 0;

    const char *const short_options = "n:g:c:p:h";
    const struct option long_options[] = {
        { "net", 1, NULL, 'n' },
        { "gateway", 1, NULL, 'g' },
        { "hop-count", 1, NULL, 'c' },
        { "priority", 1, NULL, 'p' },
        { "help", 0, NULL, 'h' },
        { NULL, 0, NULL, 0 },
    };

    while ((opt = getopt_long(argc, argv, short_options,
        long_options, NULL)) != -1) {
        switch (opt) {
            case 'n':
                network = optarg;
                break;
            case 'g':
                gateway = optarg;
                break;
            case 'c':
                rc = parse_long(optarg, &hop);
                if (rc != 0) {
                    /* ignore option */
                    hop = -1;
                    continue;
                }
                break;
            case 'p':
                rc = parse_long(optarg, &prio);
                if (rc != 0) {
                    /* ignore option */
                    prio = -1;
                    continue;
                }
                break;
            case 'h':
                print_help(route_cmds, "route", "add");
                return 0;
            default:
                return 0;
        }
    }

    rc = lustre_lnet_config_route(network, gateway, hop, prio, -1, &err_rc);

```

```
if (rc != LUSTRE_CFG_RC_NO_ERR)
    cYAML_print_tree2file(stderr, err_rc);

cYAML_free_tree(err_rc);

return rc;
}
```

For other code examples refer to

`lnet/utils/lnetctl.c`

Glossary

A

- ACL Access control list. An extended attribute associated with a file that contains enhanced authorization directives.
- Administrative OST failure A manual configuration change to mark an OST as unavailable, so that operations intended for that OST fail immediately with an I/O error instead of waiting indefinitely for OST recovery to complete

C

- Completion callback An RPC made by the lock server on an OST or MDT to another system, usually a client, to indicate that the lock is now granted.
- configlog An llog file used in a node, or retrieved from a management server over the network with configuration instructions for the Lustre file system at startup time.
- Configuration lock A lock held by every node in the cluster to control configuration changes. When the configuration is changed on the MGS, it revokes this lock from all nodes. When the nodes receive the blocking callback, they quiesce their traffic, cancel and re-enqueue the lock and wait until it is granted again. They can then fetch the configuration updates and resume normal operation.

D

- Default file layout An extended attribute on the filesystem root directory that describes the default stripe count, stripe size, and layout pattern used for new files created in a file system. This can be amended by using a default file layout on a directory or a per-file layout.
- Direct I/O A mechanism that can be used during read and write system calls to avoid memory cache overhead for large I/O requests. It bypasses the data copy between application and kernel memory, and avoids buffering the data in the client memory.
- Directory default file layout An extended attribute that describes the default file layout used for new files created within that directory. This is also inherited by new subdirectories created in that directory at creation time.
- Distributed Namespace Environment (DNE) A collection of metadata targets serving a single file system namespace. Without DNE, Lustre file systems are limited to a single metadata target for the entire name space. Without the ability to distribute metadata load over multiple targets, Lustre file system performance may be limited. The DNE functionality has two types of scalability. *Remote Directories* (DNE1) allows sub-directories to be serviced by an independent MDT(s), increasing aggregate metadata capacity and performance for independent sub-trees of the filesystem. This also allows performance isolation of workloads running in a specific sub-directory on one MDT from workloads on other MDTs. In Lustre 2.8 and later *Striped Directories* (DNE2) allows a single directory to be serviced by multiple MDTs.

E

EA	Extended attribute (also <i>xattr</i>). A small amount of metadata stored on a file that can be retrieved by a name associated with a particular inode. A Lustre file system uses EAs to store striping information (indicating the location of file data on OSTs). Examples of extended attributes are ACLs, striping information, and the FID of the file.
Eviction	The process of removing a client's state from the server if the client is unresponsive to server requests after a timeout or if server recovery fails. If a client is still running, it is required to flush the cache associated with the server when it becomes aware that it has been evicted.
Export	The state held by a server for a client that is sufficient to transparently recover all in-flight operations when a single failure occurs.
Extent	A range of contiguous bytes or blocks in a file that are addressed by a {start, length} tuple instead of individual block numbers.
Extent lock	An LDLM lock used by the OSC to protect an extent in an OST object for concurrent control of read/write, file size acquisition, and truncation operations.

F

Failback	The failover process in which the default active server regains control from the backup server that had taken control of the service.
Failout OST	An OST that is not expected to recover if it fails to answer client requests. A failout OST can be administratively failed, thereby enabling clients to return errors when accessing data on the failed OST without making additional network requests or waiting for OST recovery to complete.
Failover	The process by which a standby computer server system takes over for an active computer server after a failure of the active node. Typically, the standby computer server gains exclusive access to a shared storage device between the two servers.
FID	Lustre File Identifier. A 128-bit file system-unique identifier for a file or object in the file system. The FID structure contains a unique 64-bit sequence number (see <i>FLDB</i>), a 32-bit object ID (OID), and a 32-bit version number. The sequence number is unique across all Lustre targets (OSTs and MDTs).
Fileset	A group of files that are defined through a directory that represents the start point of a file system.
FLDB	FID Location Database. This database maps a sequence of FIDs to a specific target (MDT or OST), which manages the objects within the sequence. The FLDB is cached by all clients and servers in the file system, but is typically only modified when new servers are added to the file system.
Flight group	Group of I/O RPCs initiated by the OSC that are concurrently queued or processed at the OST. Increasing the number of RPCs in flight for high latency networks can increase throughput and reduce visible latency at the client.

G

Glimpse callback An RPC made by an OST or MDT to another system (usually a client) to indicate that a held extent lock should be surrendered. If the system is using the lock, then the system should return the object size and timestamps in the reply to the glimpse callback instead of cancelling the lock. Glimpses are introduced to optimize the acquisition of file attributes without introducing contention on an active lock.

I

Import The state held by the client for each target that it is connected to. It holds server NIDs, connection state, and uncommitted RPCs needed to fully recover a transaction sequence after a server failure and restart.

Intent lock A special Lustre file system locking operation in the Linux kernel. An intent lock combines a request for a lock with the full information to perform the operation(s) for which the lock was requested. This offers the server the option of granting the lock or performing the operation and informing the client of the operation result without granting a lock. The use of intent locks enables metadata operations (even complicated ones) to be implemented with a single RPC from the client to the server.

L

LBUG A fatal error condition detected by the software that halts execution of the kernel thread to avoid potential further corruption of the system state. It is printed to the console log and triggers a dump of the internal debug log. The system must be rebooted to clear this state.

LDLM Lustre Distributed Lock Manager.

lfs The Lustre file system command-line utility that allows end users to interact with Lustre software features, such as setting or checking file striping or per-target free space. For more details, see Section 40.1, “`lfs`”.

LFSCK Lustre file system check. A distributed version of a disk file system checker. Normally, `lfsck` does not need to be run, except when file systems are damaged by events such as multiple disk failures and cannot be recovered using file system journal recovery.

llite Lustre lite. This term is in use inside code and in module names for code that is related to the Linux client VFS interface.

llog Lustre log. An efficient log data structure used internally by the file system for storing configuration and distributed transaction records. An `llog` is suitable for rapid transactional appends of records and cheap cancellation of records through a bitmap.

llog catalog Lustre log catalog. An `llog` with records that each point at an `llog`. Catalogs were introduced to give `llogs` increased scalability. `llogs` have an originator which writes records and a replicator which cancels records when the records are no longer needed.

LMV	Logical Metadata Volume. A module that implements a DNE client-side abstraction device. It allows a client to work with many MDTs without changes to the <code>llite</code> module. The LMV code forwards requests to the correct MDT based on name or directory striping information and merges replies into a single result to pass back to the higher <code>llite</code> layer that connects the Lustre file system with Linux VFS, supports VFS semantics, and complies with POSIX interface specifications.
LND	Lustre network driver. A code module that enables LNet support over particular transports, such as TCP and various kinds of InfiniBand networks.
LNet	Lustre networking. A message passing network protocol capable of running and routing through various physical layers. LNet forms the underpinning of LNETrpc.
Lock client	A module that makes lock RPCs to a lock server and handles revocations from the server.
Lock server	A service that is co-located with a storage target that manages locks on certain objects. It also issues lock callback requests, calls while servicing or, for objects that are already locked, completes lock requests.
LOV	Logical Object Volume. The object storage analog of a logical volume in a block device volume management system, such as LVM or EVMS. The LOV is primarily used to present a collection of OSTs as a single device to the MDT and client file system drivers.
Lustre client	An operating instance with a mounted Lustre file system.
Lustre file	A file in the Lustre file system. The implementation of a Lustre file is through an inode on a metadata server that contains references to one or more objects on an OSSs.

M

mballoc	Multi-block allocator. Functionality in <code>ldiskfs</code> that enables the <code>ldiskfs</code> file system to allocate multiple blocks with a single request to the block allocator.
MDC	MetaData Client. A Lustre client component that sends metadata requests via RPC over LNet to the metadata target (MDT).
MDD	Metadata Disk Device. Lustre server component that interfaces with the underlying object storage device to manage the Lustre file system namespace (directories, file ownership, attributes).
MDS	MetaData Server. The server node that is hosting the metadata target (MDT).
MDT	MetaData Target. A storage device containing the file system namespace that is made available over the network to a client. It stores filenames, attributes, and the layout of OST objects that store the file data.
MDT0000	The metadata target storing the file system root directory, as well as some core services such as quota tables. Multiple metadata targets are possible in the same file system. MDT0000 must be available for the file system to be accessible.

MGS Management Service. A software module that manages the startup configuration and changes to the configuration. Also, the server node on which this system runs.

N

NID Network IDentifier. Encodes the type, network number, and network address of a network interface on a node for use by the Lustre file system.

Node affinity Node affinity describes the property of process threads to be affine to specific cores on a NUMA system. Without node affinity, an operating system scheduler may move threads across processors in a sub-optimal way that significantly reduces performance of the system overall.

NRS Network Request Scheduler. A subcomponent of the PtRPC layer, which specifies the order in which RPCs are handled by servers. This allows optimizing large numbers of incoming requests for disk access patterns, fairness between clients, and other administrator-selected policies.

NUMA Non-Uniform Memory Access. Describes a multi-processing architecture where the time taken to access specific memory differs depending on memory location relative to a given processor. Typically machines with multiple sockets are NUMA architectures.

O

OBD Object-Based Device. The generic term for components in the Lustre software stack that can be configured on the client or server. Examples include MDC, OSC, LOV, LMV, MDT, and OST.

OBD type Module that can implement the Lustre object or metadata APIs. Examples of OBD types include the LOV, OSC and OSD.

Object storage Refers to a storage-device API or protocol involving storage objects and offsets therein, rather than addressing storage by individual blocks.

opencache A cache of open file handles. This is a performance enhancement for NFS and files that are opened repeatedly on a client.

Orphan objects OST objects to which no Lustre file points. Orphan objects can arise from crashes and are automatically removed by an `llog` recovery between the MDT and OST. When a client deletes a file, the MDT unlinks it from the namespace. If this is the last link, it will atomically add the OST objects into a per-OST `llog`(in case a crash occurs) and then wait until the MDT unlink commits to disk. At this point, it is safe to destroy the OST objects. Once the OST object destroy is committed, the MDT `llog` records can be cancelled.

OSC Object Storage Client. The client module communicating to an OST mounted on an OSS.

OSD Object Storage Device. A generic, industry term for storage devices with a more extended interface than block-oriented devices such as disks. For the Lustre file system, this name is used to describe a software module that implements an object storage API in the kernel. It is also used to refer to an instance of an object storage device created by that driver. The OSD device is layered on a file system, either

	ldiskfs (ext4) or ZFS, with methods that implement create, destroy and other I/O operations on file inodes.
OSS	Object Storage Server. A server OBD that provides network access between the client and local OSTs.
OST	Object Storage Target. An OSD made accessible through a network protocol. Typically, an OST is associated with a unique OSD which, in turn is associated with a formatted disk file system on the server containing the data objects.
Overstriping	Using wide striping for a file that allocates multiple objects in a file to each OST. This allows the number of stripes to exceed the number of OSTs, and can improve scalability for IO and locking.

P

pdirops	A locking protocol in the Linux VFS layer that allows for directory operations performed in parallel.
Pool	OST pools allows the administrator to associate a name with an arbitrary subset of OSTs in a Lustre cluster. A group of OSTs can be combined into a named pool with unique access permissions and stripe characteristics.
Portal	A service address on an LNet NID that binds requests to a specific request service, such as an MDS, MGS, OSS, or LDLM. Services may listen on multiple portals to ensure that high priority messages are not queued behind many slow requests on another portal.
PtiRPC	An RPC protocol layered on LNet. This protocol deals with stateful servers and has exactly-once semantics and built in support for recovery.

R

Recovery	The process that re-establishes the connection state when a client that was previously connected to a server reconnects after the server restarts.
Remote directory	A remote directory describes a feature of Lustre DNE where a subdirectory may be stored on a different MDT than the parent directory. This is sometimes referred to as DNE1.
Replay request	The concept of re-executing a server request after the server has lost information in its memory caches and shut down. The replay requests are retained by clients until the server(s) have confirmed that the data is persistent on disk. Only requests for which a client received a reply and were assigned a transaction number by the server are replayed. Requests that did not get a reply are resent.
Resent request	An RPC request sent from a client to a server that has not had a reply from the server. This might happen if the request was lost on the way to the server, if the reply was lost on the way back from the server, or if the server crashes before or after processing the request. During server RPC recovery processing, resent requests are processed after replayed requests, and use the client RPC XID to determine if the resent RPC request was already executed on the server.
Revocation callback	Also called a "blocking callback". An RPC request made by the lock server (typically for an OST or MDT) to a lock client to revoke a granted DLM lock.

Root squash A mechanism whereby the identity of a root user on a client system is mapped to a different identity on the server to avoid root users on clients from accessing or modifying root-owned files on the servers. This does not prevent root users on the client from assuming the identity of a non-root user, so should not be considered a robust security mechanism. Typically, for management purposes, at least one client system should not be subject to root squash.

Routing LNet routing between different networks and LNDs.

RPC Remote Procedure Call. A network encoding of a request, often sent from a client to a server to perform a particular action.

S

Stripe A contiguous, logical extent of a Lustre file written to a single OST. Used synonymously with a single OST data object that makes up part of a file visible to user applications.

Striped Directory A striped directory is when metadata for files in a given directory are distributed evenly over multiple MDTs. Striped directories are only available in Lustre software version 2.8 or later. A user can create a striped directory to increase metadata performance of very large directories (e.g. 1M+ entries) by distributing the metadata requests in a single directory over two or more MDTs. This is sometimes called DNE2.

Stripe size The maximum number of bytes that will be written to an OST object in a RAID0-striped Lustre file before the next object in the file's layout is used, when writing data sequentially to a file. Once a full stripe has been written to each of the objects in the layout, the first object will be written to again in round-robin fashion.

Stripe count The number of OSTs holding objects for a RAID0-striped Lustre file.

T

T10-PI Checksum format defined by the T10 SCSI committee to store data checksums together with the data on supporting storage devices.

TBF Token Bucket Filter. NRS policy that assigns tokens to each rule proportional to the priority of RPCs submitted that match the rule. When the tokens for a rule have all been consumed within a time period, any remaining RPCs matching that rule must wait until the next time period to be processed.

W

Wide striping Strategy of using many OSTs to store stripes of a single file. This obtains maximum bandwidth access to a single file through parallel utilization of many OSTs. For more information about wide striping, see Section 19.9, "Lustre Striping Internals".

Index

A

- Access Control List (ACL), 321
 - examples, 322
 - how they work, 321
 - using, 321
- audit
 - change logs, 98

B

- backup, 167
 - aborting recovery, 135
 - index objects, 171
 - MDT file system, 171
 - MDT/OST device level, 170
 - new/changed files, 178
 - OST and MDT, 172
 - OST config, 133
 - OST file system, 171
 - restoring file system backup, 174
 - restoring OST config, 134
 - rsync, 168
 - examples, 169
 - using, 168
 - using LVM, 176
 - creating, 176
 - creating snapshots, 178
 - deleting, 180
 - resizing, 180
 - restoring, 178
 - ZFS to ldiskfs, 180, 180
 - ZFS ZPL, 180
- barrier, 343
 - impose, 344
 - query, 344
 - remove, 344
 - rescan, 345
- benchmarking
 - application profiling, 375
 - local disk, 367
 - MDS performance, 373
 - network, 369
 - OST I/O, 372
 - OST performance, 366
 - raw hardware with sgdd-survey, 364
 - remote disk, 370
 - tuning storage, 365
 - with Lustre I/O Kit, 363

C

- change logs (see monitoring)

- Client-side encryption, 326
- commit on share, 463
 - tuning, 464
 - working with, 463
- configlogs, 346
- configuring, 535
 - adaptive timeouts, 491
 - LNet options, 536
 - module options, 535
 - multihome, 68
 - network
 - accept, 538
 - forwarding, 538
 - ip2nets, 536
 - rnet_hhtable_size, 539
 - routes, 537
 - SOCKLND, 539
 - tcp, 537
 - network topology, 536

D

- debug
 - utilities, 569
- debugging, 435
 - admin tools, 436
 - developer tools, 436
 - developers tools, 444
 - disk contents, 442
 - external tools, 436
 - kernel debug log, 441
 - lctl example, 440
 - memory leaks, 448
 - message format, 437
 - procedure, 437
 - tools, 435
 - using lctl, 439
 - using strace, 442
- design (see setup)
- DLC
 - Code Example, 585
- dom, 224, 224, 228, 228, 229, 230, 231
 - disabledom, 231
 - domstripesize, 228
 - dom_stripesize, 230
 - intro, 224
 - lfsfind, 229
 - lfsgetstripe, 228
 - lfssetstripe, 224
 - usercommands, 224

E

- ea_inode
 - large_xattr, 161

encryption access semantics, 326
 encryption fscrypt policy, 330
 encryption key hierarchy, 328
 encryption modes usage, 328
 encryption threat model, 329
 errors (see troubleshooting)

F

failover, 16, 83
 and Lustre, 17
 capabilities, 16
 configuration, 17
 high-availability (HA) software, 84
 MDT, 18, 18
 OST, 19
 power control device, 83
 power management software, 83
 setup, 84
 feature overview
 configuration, 339
 file layout
 See striping, 182
 filefrag, 514
 fileset, 570
 fragmentation, 513

H

Hierarchical Storage Management (HSM)
 introduction, 283
 High availability (see failover)
 HSM
 agents, 284
 agents and copytools, 284
 archiveID backends, 284
 automatic restore, 286
 changelogs, 288
 commands, 286
 coordinator, 284
 file states, 286
 grace_delay, 288
 hsm_control, 287
 max_requests, 287
 policy, 287
 policy engine, 288
 registered agents, 285
 request monitoring, 286
 requests, 285
 requirements, 283
 robinhood, 289
 setup, 283
 timeout, 285
 tuning, 287

I

I/O, 258
 adding an OST, 264
 bringing OST online, 259
 direct, 265
 disabling OST creates, 259
 full OSTs, 258
 migrating data, 259
 OST space usage, 258
 pools, 261
 imperative recovery, 464
 Configuration Suggestions, 467
 MGS role, 464
 Tuning, 465
 inodes
 MDS, 30
 OST, 31
 installing, 24
 preparation, 50
 Introduction, 339
 Requirements, 339
 ior-survey, 570
 Isolation, 323
 client identification, 323
 configuring, 323
 making permanent, 324

J

jobstats (see monitoring)

K

Kerberos, 332

L

large_xattr
 ea_inode, 31
 lctl, 543
 ldiskfs
 formatting options, 29
 lfs, 504
 lfs_migrate, 512
 llobdstat, 549
 llog_reader, 550
 llstat, 550
 llverdev, 551
 ll_decode_filter_fid, 548
 LNet, 14, 66, 143, 143, 144, 144 (see configuring)
 best practice, 72
 buffer yaml syntax, 65
 capi general information, 573
 capi input params, 573
 capi output params, 573
 capi return code, 573

- cli, 56, 56, 56, 58, 61, 62, 62, 62, 64, 64, 64
 - asymmetrical route, 63
 - dynamic discovery, 60
- comments, 72
- Configuring LNet, 55
- cyaml, 573
- error block, 574
- escaping commas with quotes, 72
- features, 14
- hardware multi-rail configuration, 141
- InfiniBand load balancing, 141
- ip2nets, 68
- lustre.conf, 141
- lustre_lnet_config_buf, 581
- lustre_lnet_config_net, 578
- lustre_lnet_config_ni_system, 575
- lustre_lnet_config_route, 576
- lustre_lnet_del_net, 579
- lustre_lnet_del_route, 577
- lustre_lnet_enable_routing, 575
- lustre_lnet_show stats, 583
- lustre_lnet_show_buf, 582
- lustre_lnet_show_net, 580
- lustre_lnet_show_route, 577
- lustre_yaml, 584
- management, 139
- module parameters, 67
- network yaml syntax, 65
- proc, 495
- route checker, 71
- router yaml syntax, 65
- routes, 70
- routing example, 70
- self-test, 350
- show block, 574, 575
- starting/stopping, 139
- statistics yaml syntax, 65
- supported networks, 15
- testing, 70
- tuning, 379
- understanding, 14
- using NID, 66
- yaml syntax, 64

logs, 345

lr_reader, 570

lshowmount, 553

lsom

- enablelsom, 232
- intro, 232
- lfsgetsom, 233
- usercommands, 233

lst, 553

Lustre, 3

- at scale, 9

- cluster, 8
- components, 6
- configuring, 73
 - additional options, 81
 - for scale, 81
 - simple example, 76
 - striping, 81
 - utilities, 82
- features, 3
- fileset, 571
- I/O, 9
- LNet, 8
- MGS, 7
- Networks, 14
- requirements, 8
- storage, 9
- striping, 11
- upgrading (see upgrading)

lustre

- errors (see troubleshooting)
- recovery (see recovery)
- troubleshooting (see troubleshooting)

lustre_rmmod, 555

lustre_rsync, 555

LVM (see backup)

l_getidentity, 542

M

maintenance, 124, 131

- aborting recovery, 135
- adding a OST, 129
- adding an MDT, 129
- backing up OST config, 133
- bringing OST online, 259
- changing a NID, 127
- changing failover node address, 136
- Clearing a config, 128
- finding nodes, 125
- full OSTs, 259
- identifying OST host, 135
- inactive MDTs, 131
- inactive OSTs, 124
- mounting a server, 125
- pools, 261
- regenerating config logs, 126
- reintroducing an OSTs, 135
- removing an MDT, 131
- removing an OST, 130, 131
- restoring an OST, 130
- restoring OST config, 134
- separate a combined MGS/MDT, 136
- set an MDT to readonly, 137
- Tune fallocate, 137

MDT

- multiple MDSs, 161
- migrating metadata, 259, 259, 260, 260, 261
- mkfs.lustre, 558
- monitoring, 94, 100
 - additional tools, 105
 - change logs, 94, 95
 - jobstats, 100, 101, 102, 103, 104, 104
 - lljobstat, 105
 - Lustre Monitoring Tool, 105
- mount, 516
- mount.lustre, 560

MR

- addremotepairs, 147
- configuring, 145
- deleteinterfaces, 147
- deleteremotepairs, 148
- health, 154
- mrhealth
 - display, 157
 - failuretypes, 154
 - initialsetup, 159
 - interface, 155
 - value, 154
- mrrouting, 149
 - routingex, 149
 - routinghealth_aliveness, 153
 - routinghealth_config, 152
 - routinghealth_discovery, 153
 - routinghealth_routerhealth, 153
 - routingmixed, 151
 - routingresiliency, 151
- mrroutinghealth, 152
- multipleinterfaces, 145
- overview, 145
- multiple-mount protection, 268

O

- obdfilter-survey, 570
- operations, 107, 341
 - create, 341
 - default dir stripe policy, 116
 - degraded OST RAID, 111
 - delete, 341
 - erasing a file system, 121
 - failover, 110, 120
 - identifying OSTs, 122
 - list, 343
 - mkdir, 114
 - modify, 343
 - mount, 341
 - mounting, 108
 - mounting by label, 107

- multiple file systems, 111
- parameters, 116
- reclaiming space, 122
- remote directory, 113
- replacing an OST or MDS, 122
- setdirstripe, 114
- shutdownLustre, 108
- starting, 107
- striped directory, 114
- unmount, 342
- unmounting, 110
- ost-survey, 570

P

- performance (see benchmarking)
- pings
 - evict_client, 468
 - suppress_pings, 468
- pools, 261
 - usage tips, 264
- proc
 - adaptive timeouts, 491
 - block I/O, 480
 - client metadata performance, 489
 - client stats, 475
 - configuring adaptive timeouts, 491
 - debug, 499
 - free space, 496
 - LNet, 495
 - locking, 497
 - OSS journal, 488
 - read cache, 485
 - read/write survey, 477, 478
 - readahead, 484
 - RPC tunables, 482
 - static timeouts, 493
 - thread counts, 498
 - watching RPC, 474
- profiling (see benchmarking)
- programming
 - upcall, 518

Q

- Quotas
 - allocating, 277
 - configuring, 270
 - creating, 273
 - default, 275
 - enabling disk, 270
 - Interoperability, 278
 - known issues, 278
 - pools, 280
 - statistics, 279

usage, 275
verifying, 272

R

recovery, 455
 client eviction, 456
 client failure, 455
 commit on share (see commit on share)
 corruption of backing ldiskfs file system, 421
 corruption of Lustre file system, 422
 failed recovery, 458
 LFSCK, 423
 locks, 460
 MDS failure, 456
 metadata replay, 458
 network, 457
 oisscrub, 423
 orphaned objects, 422
 OST failure, 457
 unavailable OST, 422
 VBR (see version-based recovery)
reporting bugs (see troubleshooting)
restoring (see backup)
root squash, 322
round-robin algorithm, 219
routerstat, 565
rsync (see backup)

S

selinux policy check, 324
 determining, 324
 enforcing, 325
 making permanent, 325
 sending client, 325
setup, 25
 hardware, 25
 inodes, 30
 ldiskfs, 29
 limits, 31
 MDT, 26, 28
 memory, 35
 client, 35
 MDS, 35, 36
 OSS, 36, 37
 MGT, 28
 network, 37
 OST, 27, 29
 space, 27
sgpdd-survey, 570
space, 182
 considerations, 182
 determining MDT requirements, 28
 determining MGT requirements, 28

 determining OST requirements, 29
 determining requirements, 27
 free space, 219
 location weighting, 222
 striping, 182
stats-collect, 570
storage
 configuring, 39
 external journal, 41
 for best practice, 40
 for mkfs, 41
 MDT, 39
 OST, 39
 RAID options, 40
 SAN, 42
 performance tradeoffs, 40
striping (see space)
 allocations, 221
 configuration, 184
 considerations, 182
 count, 185
 Foreign, 217
 getting information, 187
 how it works, 182
 metadata, 114
 on specific OST, 187
 overview, 11
 per directory, 186
 per file system, 186
 PFL, 188
 remote directories, 188
 round-robin algorithm, 219
 SEL, 206
 size, 183
 stripe count limit, 186
 weighted algorithm, 219
 wide striping, 222
suppressing pings, 468

T

troubleshooting, 410
 'Address already in use', 415
 'Error -28', 416
 common problems, 412
 error messages, 411
 error numbers, 410
 OST out of memory, 420
 reporting bugs, 411
 slowdown during startup, 420
 timeouts on setup, 418
tunefs.lustre, 566
tuning, 377 (see benchmarking)
 for small files, 407

- Large Bulk IO, 406
- libcfs, 384
- LND tuning, 385
- LNet, 379
- lockless I/O, 403
- MDS binding, 379
- MDS threads, 378
- Network interface binding, 380
- Network interface credits, 380
- Network Request Scheduler (NRS) Tuning, 387
 - client round-robin over NIDs (CRR-N) policy, 390
 - Delay policy, 401
 - first in, first out (FIFO) policy, 390
 - object-based round-robin (ORR) policy, 391
 - Target-based round-robin (TRR) policy, 394
 - Token Bucket Filter (TBF) policy, 394
- OSS threads, 378
- portal round-robin, 381
- router buffers, 380
- service threads, 377
- with lfs ladvice, 404
- write performance, 407

U

- upgrading, 161
 - 2.X.y to 2.X.y (minor release), 165
 - major release (2.x to 2.x), 161
- utilities
 - debugging, 569
 - system config, 569

V

- version
 - which version of Lustre am I running?, xxiv
- Version-based recovery (VBR), 462
 - messages, 463
 - tips, 463

W

- weighted algorithm, 219
- wide striping, 31, 161, 222
 - large_xattr
 - ea_inode, 31

X

- xattr
 - See wide striping, 31