

**NOT FOR PUBLICATION
UNTIL RELEASED BY
THE SENATE ARMED SERVICES
COMMITTEE**

**STATEMENT OF
GENERAL JAMES L. JONES
COMMANDANT OF THE MARINE CORPS
UNITED STATES MARINE CORPS
BEFORE THE
SEAPOWERS SUBCOMMITTEE
OF THE
SENATE ARMED SERVICES COMMITTEE
MARCH 5, 2002**

**NOT FOR PUBLICATION
UNTIL RELEASED BY
THE SENATE ARMED SERVICES
COMMITTEE**

Chairman Kennedy, Senator Sessions, distinguished members of the Committee; it is my pleasure to report to you on the state of your Marine Corps. On behalf of all Marines and their families, I want to thank the Committee for your continued support. Your commitment to increasing the warfighting and crisis response capabilities of our Nation's armed forces and to improving the quality of life of our men and women in uniform is central to the strength of your Marine Corps. As a result, your Corps was ready when called upon on September 11, 2001. We thank you for your effort in ensuring that Marines and their families were poised to respond to the Nation's call in the manner Americans expect of their Corps.

The direction of the Corps is confident, clear, and unambiguous. The Corps understands its role as a force in readiness but also realizes that the world is changing. For 226 years, Marines have always been innovators in order to be ready for the next war. To assure success, we continually strive to be capable of rapidly adapting to new circumstances inasmuch as we recognize that the future is unpredictable.

The President's Fiscal Year 2003 Budget enables the Navy-Marine Corps Team to fight today's war on terrorism and transform itself to be ready for future challenges. This budget funds our 4th Marine Expeditionary Brigade anti-terrorism efforts, includes pay raises and new combat uniforms for our Marines and provides increased health care for our retirees. It also allows us to harness the new capabilities found in tilt-rotor technology and Short Take-Off and Vertical Landing aircraft. We have increased funding for our operating forces in day-to-day operations, training, equipment maintenance, and force protection. Additionally, our bases and stations are sustained by the President's budget, which improves such critical areas as family housing and bachelor

quarters. Furthermore, this budget's investments in ground equipment, ammunition and research and development will help us recover from prior year shortfalls.

Marines have a vision for the future, and we are moving forward with the modernization and transformational efforts needed to make this vision a reality. We fully understand that our vision cannot be achieved independently of our sister Services. Each of us has our own critical role to play in providing for our collective security. It is important that each of our contributions be, simultaneously, both unique and complementary. In particular, the Corps stresses the importance of our key partnership with the Navy. The Navy-Marine Corps Team has never been stronger, nor more necessary for our country. In fact, the essence of our combined power is our teamwork.

Americans have relied upon the Navy and Marine Corps Team to protect and promote the interests of the nation since our creation by the Continental Congress in 1775. After helping to win American independence, Naval Services acted time and again to ensure our freedom and set in motion the ascendancy of our Nation as a global power under the banner of democracy and its potential. During the darkest hours of our history, the Navy and Marine Corps Team has remained the most useful and most frequently used expression of our Nation's interests in forward presence and crisis response. Those of us who are privileged to serve in the Naval Services today have inherited a legacy that we are dedicated to preserving. Together we will continue to flourish, due to steadfast appreciation of our heritage and a commitment to a tradition of continuous innovation and change.

Teamwork is the bond that forever joins our Services and is the key to our enduring success. We have progressed from wooden ships of sail, with embarked

Marines, to modern networked Naval expeditionary strike forces that are forward deployed and full spectrum capable. We are a combined-arms force capable of ensuring America's access, including sustainable forcible entry operations to distant inland areas and austere locations. Always moving forward, we are incorporating advanced technologies to increase our capabilities to include exploiting the tremendous potential of sea control and power projection. Our innovation is not limited to equipment and weapons systems but is also reflected in the development of new operational concepts and organizational evolution. When crises emerge, the Nation can depend on the Navy and Marine Corps Team.

Today, I will describe the Marine Corps' relevance to the current security environment as well as our future role as America's sea-based, expeditionary, combined-arms force. I will also address the Marine Corps' role as the Nation's medium-weight expeditionary force, bridging the gap between America's Special Operations Forces and the Army's critical land war-winning capability. The preponderance of this statement will focus on the Marine Corps' transformation plans and our vision for the 21st Century.

I. The Marine Corps' Relevance: Power Projection from the Sea-base

For the United States to provide its citizens with security and prosperity at home and abroad it must continue to lead the effort in maintaining international stability. One only need consider the events of September 11th, and the fact that 30 percent of the United States Gross Domestic Product is directly related to global trade, to realize that America's well-being is inextricably linked to the international order. America must continue to establish and lead efforts to maintain stability around the world. This

challenge requires the integrated application of all elements of national power – economic, political, diplomatic, cultural, intellectual, technological, and military. Working in concert with the other components of national power, our armed forces perform a vital role in establishing and maintaining conditions that directly affect global stability and America’s security and prosperity. History shows that our men and women in uniform play a pivotal role in our Nation’s international credibility. It is not an exaggeration to claim that our Nation’s most important gift to world order is found in the service of our young men and women in uniform. Before anything good happens in the world, they are there establishing the framework for peace and stability.

Inasmuch as global stability is intrinsically tied to America’s relationship with other nations in the world community, the United States benefits significantly from military to military relationships around the globe. However, as nations continue to raise issues of sovereignty, especially during a crisis, we must find new ways to conduct our Nation’s necessary engagements and have the means to respond to crisis without being excessively restricted by geo-political issues. In the 21st Century, we are likely to see a change in the number and type of large, quasi-permanent American bases around the world as defined by the post-Cold War era. We must begin to develop alternatives to ensure that we are able to maintain our peacetime presence and our crisis response capabilities. 21st Century basing initiatives are issues that will have to be addressed in the near future.

We cannot deter aggression, nor defeat future adversaries, solely with military capabilities based at home. Regional engagement requires presence, and there is no such thing as truly effective “virtual presence.” The inherent mobility and flexibility of Naval

forces in providing off-shore basing options is an effective counter to increasing limitations to access and basing rights. America's stabilizing influence overseas is contingent upon our ability to deploy, employ, and sustain persistent military forces from the sea. Indeed, the Navy-Marine Corps Team's sea-based power projection capabilities are a cornerstone of our military's contribution to our enduring security and that of our allies.

Sea-based capabilities provided by the Navy-Marine Corps Team are an important means for America to cultivate its relationship with the world, providing the advantage, both in peacetime and in crisis response operations, of being able to control the size of our "footprint" ashore. Sea-basing also provides the operational advantages of force protection, operational maneuver space, and the sanctity of sovereign platforms from which we can engage adversaries.

The Navy-Marine Corps Team's sea-based capabilities have been re-validated over the past several months. In Afghanistan, sea-based Naval forces provided a significant portion of tactical air sorties and the initial deployment of major, sustained ground force presence, reaching over 600 miles inland. [See Figure 1]

Operation Enduring Freedom has also proven the value of the Navy-Marine Corps Team as an important element of a Joint Force.

SHIP TO OBJECTIVE MANEUVER (STOM)

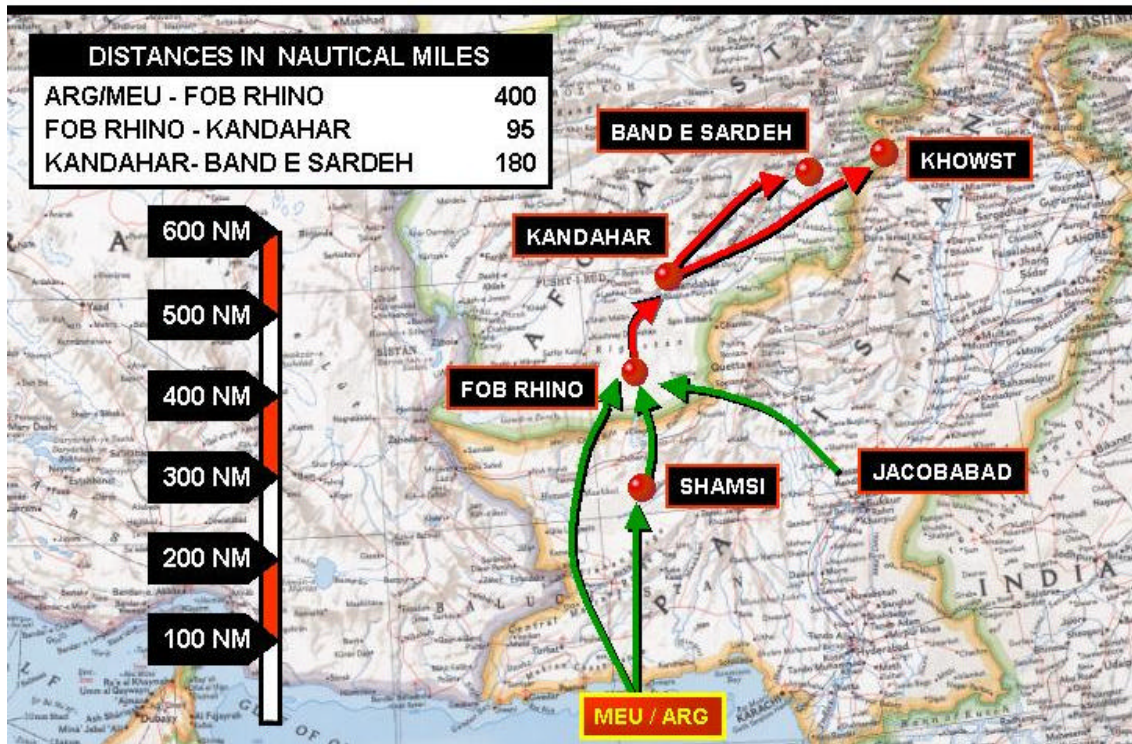

[Figure 1]

Important contributions were made through Marine integration with Special Operations Forces, the Army, and the Air Force in the areas of Intelligence, Surveillance, and Reconnaissance capabilities to long-range strike and close air support capabilities. The Marine Corps has demonstrated that the Marine brigade – a flexible, medium-weight, combined arms, expeditionary force – is not only responsive, but also a full and effective partner in Joint and Coalition operations.

II. The Marine Corps' Role: A Scalable, Sustainable, Forcible Entry Force.

The Marine Corps provides our Nation and its Joint Force Commanders the full scope of military capabilities required to respond to the broad spectrum of threats and

potential missions that confront America's armed forces today and in the future. For six percent of the Department of Defense's budget, the Marine Corps provides twenty percent of our Nation's ground combat maneuver battalions, tactical fixed-wing aircraft squadrons, and attack helicopter squadrons, as well as one-third of its active duty combat service support.

If there is a lesson to be learned from ongoing operations in Afghanistan, it is that there is tremendous power and capability in the diversity of our armed forces today. Joint Force Commanders must have the fullest possible range of options and capabilities available in order to apply the desired effects, both lethal and non-lethal, in any given scenario. Indeed, the flexibility and robustness of America's armed forces is a product of the varied and unique capabilities each Service contributes to our Nation. Accordingly, our capabilities need to be complementary, not duplicative, if we are to provide the diverse and versatile capabilities needed to confront the uncertain threats of the future. Together, our Joint force forms a mosaic of integrated capabilities to defeat the myriad threats and challenges we may face today and tomorrow. Enhancing these capabilities across the force is in the national interest.

Marine Air-Ground Task Forces have proven their utility in meeting challenges and exploiting opportunities. The versatility of the Marine Expeditionary Brigade is emblematic of the scalability of our Marine Air-Ground Task Forces. In size and capability, these brigades are midway between our "light" Marine Expeditionary Units and our "heavy" Marine Expeditionary Forces. Furthermore, our Marine Expeditionary Brigades can either deploy on amphibious shipping or be airlifted into a theater of operations to link up with equipment and supplies aboard Maritime Prepositioning Ships.

While the global war on terrorism has demonstrated the current capabilities of the Navy-Marine Corps Team, our continuous transformation and modernization promise even greater future capabilities for the Marine Corps. Transformation is an ongoing process, however, not an end-state. It spans decades of innovation and experimentation. It is also not limited to technology, but includes change in our organizational structure, operational concepts, and business practices.

The Marine Corps has always been at the forefront of transformation and innovation. Throughout our history, the Marine Corps has changed and evolved – from ship security, to naval constabulary, to light infantry, to an amphibious assault force, to an air-ground expeditionary team. In the past, our development of close air support, amphibious warfare, vertical envelopment, Short Take-Off and Vertical Landing technology, and maritime prepositioning have benefited our Joint warfighting capability. Today, the Marine Corps remains true to its warrior culture and continues in a tradition of change. Drawing on our history of transformation, the Marine Corps is moving forward with new concepts, innovation, and exciting experimentation. Our focus is on the creation of new capabilities, which will yield the operational advantages we seek to have in dealing with future conflicts.

III. The Marine Corps' Transformation: Concepts, Technologies, and Organizations

Although many think of transformation primarily in terms of weapons systems, true transformation results from a synthesis of new technologies with strategic vision, revolutionary operational concepts, and agile, adaptive organizations. Clearly, we must harness the potential military benefits of rapid advances in technology. The V-22 Osprey

is but one example of the potential of proven transformational technology. The path to transformation involves a robust program of experimentation with new concepts, capabilities and operational prototypes while actively pursuing forward-looking science and technology efforts. As we experiment and introduce new capabilities, we will rapidly mainstream the changes into our ready forces. [See Figure 2]

CONVERGENCE OF OPERATIONAL CAPABILITIES

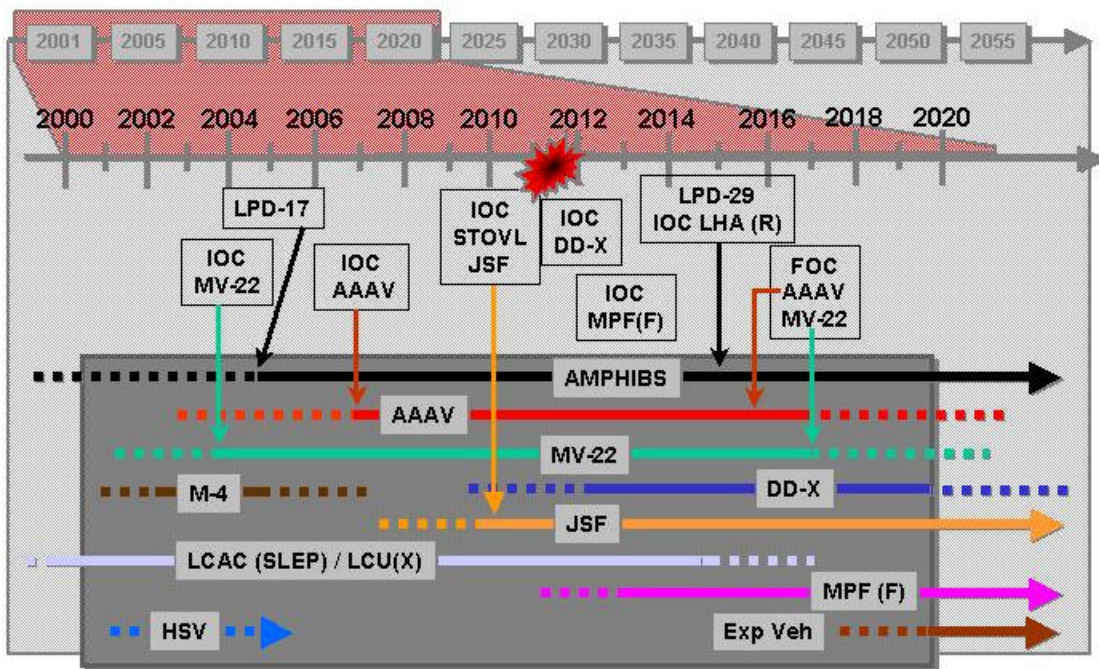

[Figure 2]

A. Transformation of Operational Concepts and Better Business Practices

Technological innovation plays a paradoxical role in military transformation. With each problem it solves, technological innovation tends to introduce new challenges

and opportunities. Operational concepts can offset these tensions by finding the means to capitalize on technological strengths and also guard against creating new weaknesses. In light of heightened fiscal awareness and the need to be effective with our resources, we must reform our business practices to maximize available resources and develop more expedient means of fielding programs and equipment. With this in mind, the Marine Corps is committed to transforming its operational concepts and business practices.

The ongoing process of conceptual change is embodied in the recent publication of our overarching concept, *Expeditionary Maneuver Warfare*. It is the foundation for the way the Marine Corps will conduct operations in the 21st Century. *Expeditionary Maneuver Warfare* is the union of our core competencies, maneuver warfare philosophy, expeditionary heritage, and the concepts by which we organize, deploy, and employ forces. It emphasizes the unique and proven capabilities the Marine Corps provides Joint Force Commanders and the synergy created when leveraged with the complementary capabilities of other Services and agencies. These capabilities translate into power projection designed to promote global security and reassure our allies and friends, while deterring and defeating adversaries and potential foes.

Central to our conceptual transformation is the potential power represented in a future integrated sea-base. At-sea arrival and assembly, selective off-load, and at-sea reconstitution capabilities stand to revolutionize the way Naval forces project power and influence around the globe. Our evolving logistics concepts promise indefinite sustainment of Marine forces, both afloat and ashore. As well, Marine forces afloat typically rely upon the Command, Control, Communications, and Computer (C4) capabilities aboard amphibious shipping to provide critical reach-back connectivity to

deployed elements of the Marine Air-Ground Task Force, and communications with Joint and multinational forces. These afloat C4 capabilities are crucial to the success of sea-basing and to achieving the full potential of Naval power projection.

The Marine Corps' sea-basing strategy is yet another illustration of continued transformation in operational concepts. Recognizing the increasing limitations on future basing potential of American forces overseas and the simultaneous need for the United States to maintain a forward presence, the Navy and the Marine Corps are developing a forward presence strategy as an extension and augmentation of our concept of sea-basing. Sea-basing is the formation of Joint assets at sea to project and sustain combat power ashore, while reducing or eliminating our landward logistics footprint during combat operations. The sea-based presence strategy boosts forward engagement during peacetime by increasing the number of countries that we may visit without being permanently stationed at large fixed-bases in host nations. Marines can deploy from country to country and advance diplomatic and informational efforts through military-to-military relations, small unit training, liaison exchanges, and exercises. III Marine Expeditionary Force's annual Cooperation Afloat Readiness and Training in the Asia-Pacific region is an illustration of this concept.

In addition to codifying overarching conceptual innovations, the Marine Corps is adjusting its tactics, techniques, and procedures to better support conceptual change. Marine Aviation Weapons and Tactics Squadron – 1 is adapting tactics, techniques, and procedures for the employment of aviation operations in urban terrain – a vital, yet challenging environment today and in the future. Advancements have been made in target selection and tracking, weapon selection and employment, friendly unit position

identification, command and control, and staff planning. Likewise, the Marine Corps is actively engaged in the development of the underlying concepts of Network Centric Warfare for Naval expeditionary forces. We are exploiting state-of-the-art information and networking technology to improve situational awareness and to integrate widely dispersed sensors, forces, and weapons. Network Centric Warfare will allow commanders to achieve mission objectives rapidly and decisively by concentrating the combined fire and maneuver of Naval forces afloat and ashore at decisive locations and times. Similarly, the Marine Corps led Joint Non-Lethal Weapons Directorate is forging the way for the development of non-lethal technologies, as well as the tactics, techniques, and procedures for effectively employing their effects. Congressional funding of the Non-Lethal Technology Innovation Center at the University of New Hampshire will continue to provide further stimulus for the experimentation and formulation of doctrine that guides the tactical use of these new weapons.

Just as it is transforming its doctrine, the Marine Corps is also transforming its business practices. Our readiness is a reflection of balancing the demands of current requirements around the globe with the imperative to invest and be prepared for the future. This balance can – over the long haul – be achieved only if resources are reallocated from overhead and support activities to our fighting forces. To accomplish this reallocation of resources, we are adopting better business practices to achieve greater cost-effectiveness. There are several different avenues that the Marine Corps is taking to make this happen. We are streamlining organizations to eliminate redundancy and maximize integration. We are also reducing excess support structures to free resources and focus on core competencies.

To transform our business practices, the Marine Corps must increasingly rely on business intelligence and associated technologies promoting access to information. We consider information to be a strategic asset, and by assuring access to information, we will improve the operational agility of the Marine Corps. Our efforts to promote enterprise management of information technology confirm our need for a common infrastructure that includes a shared data environment, realignment and consolidation of many of our information systems, and the search for cost-effective strategies.

Commercialization, privatization, and out-sourcing are among the methods the Marine Corps has used to reduce costs, but ultimately it is competition between public and private sources that has led to increased savings. The Marine Corps has initiated competition between government sources and private sector commercial sources for a broad number of activities, best seen in the Marine Corps' application of such competition vis-à-vis its bases and stations. To operate our 15 major installations – essentially providing the range of support services typical of a municipality – a labor force of approximately 20,000 Marines and 14,000 civilians are employed. One of the processes we have used in these competitions to save money is Activity-Based Costing and Management. This process provided our installation commanders information that enabled them to save over \$30 million last year by analytically measuring the costs of particular work and evaluating the performance of that work.

Another example of turning to the private sector and using competition to bring down costs is the success of our new camouflage utility uniform. The uniform was created, tested, produced, and fielded by the Marine Corps – with the use of a new digital camouflage design technique – through a single source vendor, yielding a product that is

superior in quality, comfort, and cost to that in existence today. We are extremely pleased with this innovative uniform that not only costs less in the long run, but is a product improvement benefiting our Marines. All of this was achieved within a one year period.

Just as the Marine Corps' new utility uniform is an example of both tactical and business innovation, so too the transformation of operational concepts and business practices are seen together in our Integrated Logistics Capability. The Integrated Logistics Capability is redefining and realigning our supply and maintenance process by providing our logisticians with greater awareness of equipment status, increasing their capacity to more rapidly and effectively respond to logistical requirements on the battlefield. The simple objective of our Integrated Logistics Capability is to avoid weighing down the warfighters with the requirement to haul, protect, and administer massive amounts of supply material. The foundation of this concept and business practice is a revolutionary change in military methodology: shifting from massive inventories to small inventories. With the use of new technologies and practices, proven in the private sector, the Corps will, in essence, create a "new order" for its logistics enterprise and undertake the revolutionary changes necessary to ensure that it continues to be the premier fighting force in the world. Second Force Service Support Group at Camp Lejeune, North Carolina, is currently testing many of these new processes in a year long "proof of concept" to validate the direction in which we are heading. These efforts will allow Marine logisticians to support the battlefield of the 21st Century with a smaller logistical footprint in a more cost-effective manner.

B. Transformation and Modernization Through Harnessing Technologies

With the foundation of requirements drawn from its new concepts, the Marine Corps is transforming its weapons systems and assets throughout the five elements of our Marine Air-Ground Task Forces – our ground, aviation, logistics, and command elements, as well as our supporting establishment. The following examples are but a few of our transformational and modernization efforts. Many of our investments involve modernization of existing capabilities vital to effectively and efficiently fulfill our core competencies. A more comprehensive description of the Marine Corps' entire acquisition program can be found in the Marine Corps' *Concepts & Issues: Forging the Future Marine Corps*.

Amphibious Shipping for Sea-basing

We are a maritime nation and we must capitalize on this part of our national character to ensure that we are ready for the challenges that are over the horizon. The requirement for our amphibious shipping remains the linchpin of the Corps' ability to influence the international security landscape, project power, and protect the Nation's interests during peacetime and crises. While it has long been recognized that we require an amphibious ship force structure capable of simultaneously lifting the assault echelons of three Marine Expeditionary Brigades, today's amphibious lift can support only two-thirds of this requirement in certain aspects of the lift footprint. I strongly recommend that we commit to redress this shortfall as a matter of urgent priority.

We are grateful for your support in replacing four classes of older ships with the new LPD-17 *San Antonio* amphibious ship class. Delivery of these 12 ships to the fleet is

currently planned to be complete in 2015. However, we remain concerned about further schedule slippage in the LPD-17 program. Such delays compromise our ability to fulfill our global forward presence responsibilities and must be avoided. Similarly, we are concerned with replacing the LHA-1 *Tarawa* class ships. Considering the extended time-frame for ship design, construction, and delivery, we need to ensure now that we are ready to replace the *Tarawa* class when they reach the end of their 35 year service life starting in 2011. [See Figure 3]

Expeditionary Lift (MEB Assault Echelons)

- Five lift fingerprints based on the 1991 DoN Lift II Study
- Assumes the 12th LPD 17 class ship delivers in FY15
- *LST 1184 & LSD 39 will decommission in FY02/03*
- *LHA Tarawa Class first decommission in FY11*
- *Current ships have serious problems*

FY	2002	2003	2004	2005	2006	2007	2015
Troops	2.73	2.68	2.68	2.71	2.67	2.66	2.63
Vehicle SqFt	2.10	2.01	2.01	2.08	2.14	2.17	2.48
Cargo CuFt	3.71	3.70	3.70	3.76	3.75	3.78	3.75
VTOL	3.25	3.25	3.25	3.3	3.32	3.35	3.43
LCAC	3.50	3.42	3.42	3.46	3.42	3.54	3.83

Expeditionary Lift Requirement: 3.0 MEB AE

[Figure 3]

The leases of our current fleet of Maritime Prepositioning Ships (MPS) will expire in FY 2009, FY 2010, and FY 2011. The development of advanced Maritime Prepositioning capabilities, High Speed Vessel platforms, and new lighterage vessels, will significantly increase the strength and flexibility of our sea-based expeditionary operations. The marriage of a modern amphibious fleet with modern Maritime

Prepositioning Shipping capable of hosting at-sea arrival and assembly of forces will minimize the requirement for access to secure ports and airfields, and give our Nation an unmatched asymmetrical advantage in projecting power.

Tilt-Rotor Aircraft

The V-22 Osprey remains the Corps’ number one aviation acquisition priority. Recent actions in Central Asia have only reinforced the immediate need for this truly transformational capability. [See Figure 4]



[Figure 4]

Tilt-rotor technology holds the promise to revolutionize aviation – we should not be afraid to embrace this promise. Both the Department of Defense’s Panel to Review the

V-22 Program and the National Aeronautics and Space Administration's Tiltrotor Aeromechanics Phenomena Assessment Panel concluded that tilt-rotor technology is sound and that mishaps have been the result of engineering deficiencies that can be solved. The V-22 will radically increase the Marine Corps and Special Operations Command's operational reach and tactical flexibility. The Osprey's superior range, speed, and payload will give Marines and Special Operations Forces the ability to accomplish combat missions and other operations from distances previously unattainable, with response times far faster than possible with other airframes. The battlespace of the future will demand capabilities that provide rapid and effective maneuver. Through the use of the V-22's increased speed and range, we not only improve our ability to influence the tempo of operations, but we provide our forces with greater survivability. These capabilities are the foundation for how we have planned to transform our operational concepts and intend to reorganize our force structure.

We are aware of the challenges associated with the Osprey but are pleased that the Under Secretary of Defense for Acquisition, Technology, and Logistics has announced that a new comprehensive flight test program for the V-22 will start this Spring. This flight test effort will be "event-driven," as opposed to being "time-driven." Both the Secretary of the Navy and the Under Secretary of Defense for Acquisition, Technology, and Logistics will periodically review flight test results to assess progress.

Short Take-Off and Vertical Landing Aircraft

In late October 2001, the contract was awarded for the Joint Strike Fighter, signaling a new era in naval aviation. The advantages of a stealthy strike fighter capable of taking off from an expeditionary base on land or at sea, fly in supersonic cruise, accomplish its mission with advanced sensors and weapons, then return to its expeditionary site are dramatic. This aircraft will transform the very foundations of tactical air power. It will provide the reliability, survivability, and lethality that our forces will need in the years ahead. Moreover, the Short Take-Off and Vertical Landing Joint Strike Fighter variant provides operational access to more than three to five times the number of airfields available around the world that are currently capable of supporting our so-called “legacy” aircraft. The Short Take-Off and Vertical Landing Joint Strike Fighter can also operate from both conventional carriers and amphibious assault ship decks, effectively doubling the number of shipborne platforms available for operations. As these highly capable aircraft move from sea-based platforms to expeditionary airfields, they can effectively decrease response time for missions by 75 percent and increase time-on-station by 50 percent. These capabilities represent a significant increase in strategic agility, operational reach, and tactical flexibility over conventional aircraft.

Fire Support Systems

Of critical interest to our Marine Air-Ground Task Forces is the status of our fire support systems on land, at sea, and in the air. We currently have an acute shortage of fire support. It is vital for us to move ahead with existing programs to provide our

Marines with this important warfighting enhancement. Indeed, the funding, testing, and development of our systems are vital. The Lightweight 155 Howitzer is needed to replace our aging “legacy” field artillery weapons. The High Mobility Artillery Rocket System, moreover, promises to be rapidly deployable and will be a key part of our expeditionary operations, firing both precision and area munitions under all weather conditions, as well as extending our ground-based fire support umbrella to 60 kilometers. In addition to these fire support systems, we need the Ground Weapon Locating Radar to protect our forces against our adversaries’ counter-battery fires. We should also continue to invest in Naval Surface Fire Support. Remedying the fire support shortfall we have lived with for much of the last two decades is crucial.

Advanced Amphibious Assault Vehicles

The Advanced Amphibious Assault Vehicle program remains the Corps’ highest ground acquisition priority and promises to allow high-speed surface maneuver from ship-to-shore as well as on land. This vehicle will be able to deploy to objectives from over the visual horizon, 25 miles and beyond, and will allow our ships to remain beyond the range of many threat weapons and surveillance systems. It will help off-set an enemy’s anti-access strategies and bolster expeditionary operations from the sea. Furthermore, the Bushmaster II 30mm cannon will give the vehicle a lethal direct fire capability. The Advanced Amphibious Assault Vehicle will be a decisive expeditionary warfare tool for operations in littoral areas world-wide.

High Speed Vessel

High-speed, intra-theater sealift, catamaran vessels provide phenomenal increases in speed and tactical flexibility for our Navy-Marine Corps Team. Building on operational use of the Royal Australian Navy's *HMS Jervis Bay*, our *Joint Venture High Speed Vessel* promises to reap new developments that will lead to new capabilities. Additionally, leasing the 331-foot commercial catamaran *Austal West Pac Express, III* Marine Expeditionary Force has demonstrated the viability of such vessels, using it to transport Marines and their equipment to training exercises through out Asia – lifting 950 Marines and 550 tons of materiel per trip, the equivalent of 14 to 17 military cargo aircraft. The Navy-Marine Corps Team's current requirement is for a craft that can transport 400 tons of cargo, travel 1,200 miles without refueling, and achieve a speed greater than 40 knots. We are confident in the High Speed Vessels capacity to deliver these capabilities and transform our intra-theater mobility.

Tactical Unmanned Aerial Vehicles

Unmanned Aerial Vehicles have already seen extensive action in the war against terrorism and their use is expanding. This technology's potential, combined with its ability to conduct dangerous missions without the risk of personnel casualties, make this a truly transformational asset. The Navy and Marine Corps' Vertical Take-Off and Landing Unmanned Aerial Vehicle Engineering Development Model program is designed to test and evaluate various sensor packages and the Tactical Control System architecture for use in future Tactical Unmanned Aerial Vehicles. In the interim, Marine Corps Pioneer systems will be upgraded to perform Unmanned Aerial Vehicle functions

(Reconnaissance, Surveillance, and Target Acquisition). Presently, Marine Corps Unmanned Aerial Vehicles are preparing to deploy to Central Command's area of responsibility.

Aerial Refueling

Replacement of our aging KC-130 Hercules fleet with KC-130J aircraft is necessary to ensure the viability and deployability of Marine Corps Tactical Aircraft Refueling and Assault Support well into the 21st Century. The KC-130J's performance features include increased cruising airspeed, night vision compatible interior and exterior lighting, enhanced rapid ground refueling capability, digital avionics, and powerful propulsion systems. These strengths promise lower life-cycle expenses and eliminate the need for costly KC-130F/R Service Life Extension Programs. In sum, the KC-130J gives us the aerial refueling capability required to meet our current and future tactical aerial refueling demands.

Maritime Prepositioning Shipping Support Facility

Supporting the Marine Corps' Maritime Prepositioning Shipping, the Blount Island facility in Jacksonville, Florida, is truly a national asset that must be secured for long-term use. Its peacetime mission to support the Maritime Prepositioning Force has been of exceptional value to the Corps, but its wartime capability of supporting massive logistics sustainment from the Continental United States gives it strategic significance. The purchase of Blount Island is planned for Fiscal Year 2004, when our current lease of the facility will expire.

Command and Control

Command and Control technologies being introduced into Marine operating Forces are key to making Expeditionary Maneuver Warfare a reality. Marine forces once ashore will utilize the Lightweight Multi-band Satellite Terminal, Tactical Data Network, and High Frequency Automatic Link Establishment Radios to link widely dispersed forces into the Network Centric environment. These technologies will result in capabilities that will greatly increase the operational agility of your Marine Corps.

C. Transformation of Organizational Structure

The transformation of our weapons systems and equipment as well as our operational concepts and business practices is a difficult task. Transforming how we organize ourselves is even more difficult. Nonetheless, building on its institutional legacy of adapting to match the threats and missions of a given time, the Marine Corps is reorganizing its structure. Furthermore, at the core of transforming our organization, is the optimizing of our greatest asset, our Marines.

One of our leading examples of transformational reorganization is the 4th Marine Expeditionary Brigade (Anti-Terrorism). The 4th MEB (AT) combined our Marine Security Guards stationed at America's embassies around the world, Fleet Anti-Terrorist Security Teams, and Chemical Biological Incident Response Force with an organic aviation component, combat service support element, and specialized anti-terrorism infantry battalion, as well as a command element with dedicated planners, coordinators, and liaison officers for anti-terrorism operations. The 4th MEB (AT) has had an

immediate impact, deploying to our re-opened embassy in Kabul, as well as supporting anthrax decontamination at the Capitol and security at the Olympics and the State-of-the-Union address. In the near future, all deployable units will deploy with an anti-terrorism capability.

In addition to standing up the 4th MEB (AT), we are looking at other organizational transformation initiatives. We are looking at additional ways to optimize our forces by realigning outdated structures to reflect new realities. Now is the time to consider how to best organize our forces to meet the needs of this transformational era.

Similar self-examination has led to successful change in our supporting establishment. Three illustrations of this are Marine Corps Combat Development Command, the Marine Corps Intelligence Activity in Quantico, Virginia, and Materiel Command in Albany, Georgia. By reorganizing the Marine Corps Combat Development Command we have redefined its role in supporting Marine Operating Forces and the Service Headquarters. It has emerged as the Corps' home for long-range thinking and has taken on the role of coordinating requirements with the Navy as well as facilitating the Marine Corps' relationship with Joint Forces Command. The Marine Corps Intelligence Activity, likewise, has been highly successful in validating our intelligence reach-back concept. Exploiting both new command relationships and connectivity, the Marine Corps Intelligence Activity is providing timely, accurate intelligence to our globally deployed tactical forces. Similarly, by establishing Materiel Command we have created a unity of effort and streamlined processes for the Marine Corps' acquisition and logistics support functions and ground weapons/equipment life cycle management processes. Material Command transformation initiatives for materiel readiness

improvements and increased visibility of total ownership costs will achieve significant future cost avoidance and savings. This allows the Installations and Logistics Department at Headquarters Marine Corps to more effectively concentrate on policy decisions and support to the operating forces and the regional combatant commanders. In each of these reorganizations, optimizing efforts of the men and women who serve our Corps has been our primary intent.

Our People

Our highest priority remains unchanged: Marines, their families and our civilian workforce. The most advanced aircraft, ship, or weapons system is of no value without highly motivated and well-trained people. People and leadership remain the real foundations of the Corps' capabilities.

It is important to note that the Marine Corps operates as a Total Force, including elements of both active and reserve components. We continue to strengthen the exceptional bonds within our Total Force by further integrating the Marine Corps Reserve into ongoing operations and training. Both Marine Expeditionary Force Augmentation Command Elements, two infantry battalions, two heavy helicopter squadrons, two aerial refueler transport detachments, as well as other units have been mobilized to support Operation Enduring Freedom. Called to duty, over 3,000 Marine Reservists are providing seamless support from operational tempo relief at Guantanamo Bay to augmentation at Camp Pendleton and Camp Lejeune.

Because our people are our number one priority, safety in the Marine Corps is a critical concern. While it is essential to maintaining our readiness, it is also a vital

element of the quality of life that we provide our Marines and their families. I am pleased to report that 2001 was a banner year for safety in the Marine Corps. The Aviation community set a record, posting the lowest Class A mishap rate in the Corps' history. Through education, vigilance, and command involvement we reduced privately owned vehicle fatalities 39 percent last year. And overall, we had our second lowest mishap fatality rate in 14 years. These are all very positive signs in our quest to safeguard our most precious assets, our Marines.

One factor contributing to our safety challenge is that we are a young force. The average age of our Marines is 24, roughly six to eight years younger than the average age of the members of the other services. This is part of the culture of the Corps as our unique force structure shows 68 percent of our Marines being on their first enlistment at any one time. The nature of our force structure requires us to annually recruit 41,000 men and women into our enlisted ranks. To fill this tremendous demand, our recruiters work tirelessly and have consistently met our accession goals in quality and quantity for over six and a half years. The performance of our recruiters has been superb.

Retention is just as important as recruiting. We are proud that we are meeting our retention goals across nearly all military occupational specialties. Intangibles – such as the desire to serve the Nation, to belong to a cohesive organization, and to experience leadership responsibilities through service in the Corps – are a large part of the reason we can retain the remarkable men and women who choose to stay on active duty. Concrete evidence of this phenomenon is seen in our deployed units, which continually record the highest reenlistment rates in the Corps. The Selective Reenlistment Bonus Program has been an additional, powerful tool to meet our retention goals. Increases for the Selective

Reenlistment Bonus Program, as well as the targeted pay raise initiative, will go a long way toward meeting our retention goals and helping take care of our Marines and their families.

While we recruit Marines, generally, we retain families. The effectiveness of our Marines is dependent, in large measure, on the support they receive from their loved ones. Our families are therefore vital to our readiness. Increased pay, as well as improved housing and health care, directly influence our families' quality of life and, in turn, enhances the readiness of our units. Your support of our families' quality of life has greatly contributed to our retention success. We are extremely thankful for the enactment of much-needed improvements to the TRICARE system for our active duty personnel and for our retired veterans. Thank you, as well, for continuing to support increases in the Basic Allowance for Housing that help our Marines meet the rising costs of rent and utilities within the limits of their housing allowances.

This Committee has provided considerable support to our Marines and their families and the Marine Corps has also improved services to our families in hopes of further enhancing their quality of life. We have established Marine Corps Community Services aboard our installations to better provide for both our Marine families as well as our single Marines, who constitute nearly 60 percent of our total active force. We have also sought to recognize and support our Marines and families with special needs and I am proud to say that both the Marine Corps' Exceptional Family Member Program and the Military Committee for Persons with Disabilities were the recipients of the 2001 S. Robert Cohen Annual Achievement Award for their commitment to facilitating and coordinating support and services to families with special needs.

Similarly, seeking to be more responsive to our Marines and to enhance their career opportunities, we have undertaken a number of manpower reforms to better manage the force. Through the personal involvement of commanders, career planners, and leaders throughout the chain of command, we have been able to meet our retention goals, stabilize our force, and reduce the burden on our recruiters. We are investing considerable resources to successfully recruit, develop, and retain the civilians who work alongside our Marines. Our strategic plan in this regard is to develop civilian career programs that integrate and advance technical and leadership competencies.

We are also investing in our Marines by improving how we train and educate them. We believe the old adage, “you fight the way you train.” Because of this, our training exercises are becoming increasingly Joint and combined to provide our Marines with the experience that they will need when they are called upon to respond to crises that require them to work alongside our sister services and partners from other nations. Our ability to effectively operate in both joint and coalition environments was clearly evident in the experiences of the Marines of Task Force 58 in Afghanistan. However, we are increasingly finding that the training and mission effectiveness of our Marines is degraded by the many forms of encroachment on our bases and stations. We need your continued support to ensure that the growing complexity and expense of encroachment issues do not curtail our efforts to conduct meaningful training. Encroachment issues will continue to be a 21st Century problem.

Experience, in tandem with education, is the best foundation for dealing with both difficulty and fortuity. Accordingly, we are not solely focused on training our Marines, but on educating them as well. We have expanded our non-resident education programs

to ensure that greater numbers of Marines have the opportunity to better themselves. We are also adjusting our policies to better accommodate family realities – such as spouses with careers or children with exceptional needs – when selecting officers to attend various schools that require a change in duty station. We have instituted a “National Fellows program” for competitively selected junior officers and staff non-commissioned officers to experience the corporate world, think tanks, non-governmental organizations, and the workings of Congress. The experiences they receive will broaden perspectives and provide valuable insights that will strengthen our capacity to innovate and adapt in the years to come.

The Marine Corps’ commitment to training and education, as well as our commitment to our “warrior culture,” is reinforced in our recently instituted martial arts program. We have developed a discipline unique to the Corps and we are in the process of training every Marine in its martial skills. This program promotes both physical prowess and mental discipline. Successive levels of achievement are rewarded with different colored belts reflecting a combination of demonstrated character, judgment, and physical skill. This training will benefit Marines in the complex missions we face; especially in peacekeeping and peacemaking operations where physical stamina and mental discipline are vital to success. At its heart, our martial arts training is fundamentally focused on mentoring our young men and women and helping them to understand that the keys to mission accomplishment are often a matter of combining intelligence, strength, and self-control to influence circumstances, rather than simply resorting to the application of deadly force. The warrior ethos we instill in our Marines,

transforms them into intelligent and disciplined warriors, and mirrors the Marine Corps' own transformation in equipment, doctrine, and structure.

IV. Conclusion

In summary, the Marine Corps' transformation is a synthesis of new operational concepts and better business practices, leap-ahead technologies, and realigned organizations. This transformation promises to exponentially increase the Corps' sea-based capabilities as America's medium-weight expeditionary force in the years ahead. Our capabilities, combined with those of our sister Services, form an integrated array that provides America with the diversity and versatility she needs to confront different threats and environments and accomplish disparate missions. In close partnership with the Navy, we are proud of what our Corps contributes as America's forward engagement and expeditionary combined-arms force. We are grateful to you for your leadership and for the unwavering support you provide to your Corps of Marines.