

How to remove 206GTi front bumper (© PVL)



This is how it looks like with the old grill...



and this closer

How to remove 206GTi front bumper (© PVL)



Remove the four mushroom clips (holding the plastic grill to the car) by...ae second one three ribs to the right of the filler hole, in the middle between the two longitude ribs



pulling out the centre piece first and the outer parts secondly.

How to remove 206GTi front bumper (© PVL)



Remove the M6 Torx30 bolts, situated on the two ends of the upper grill.



Bend the plastic grill up/forwards past the security hook.

How to remove 206GTi front bumper (© PVL)



Grab down behind the grill and loosen it by simply squeezing the six clips one by one...



...until it's free and remove it from the car.

How to remove 206GTi front bumper (© PVL)



Loosen the M6 Torx30 bolt located bang in the middle, just behind the lion.



Now comes the sweaty part: taking off the colour coded plastic section “between” the headlights. If you have and nails and you have some strength in your fingers, it’s possible to pull it towards you loosening it from the front wheel arch. If not use something to pry it loose, but at all circumstances **do not use a screwdriver!**

How to remove 206GTi front bumper (© PVL)



This is how it looks when it has popped off neatly...



...but sometimes the clips will break!

How to remove 206GTi front bumper (© PVL)



This is how a new one looks like ☺ ...

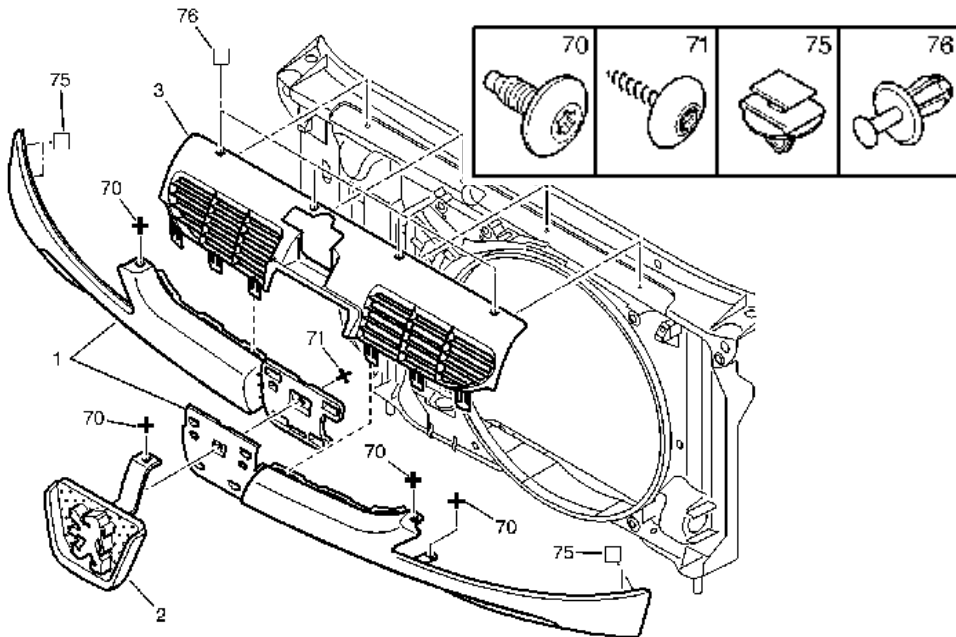

...but don't worry as they only cost a few cents, but have at least four ready before starting this! The number for these clips (75) is: 6995 X3
The number for the named "mushroom" clips (76) is: 6997 83, if you broke one or two.

How to remove 206GTi front bumper (© PVL)

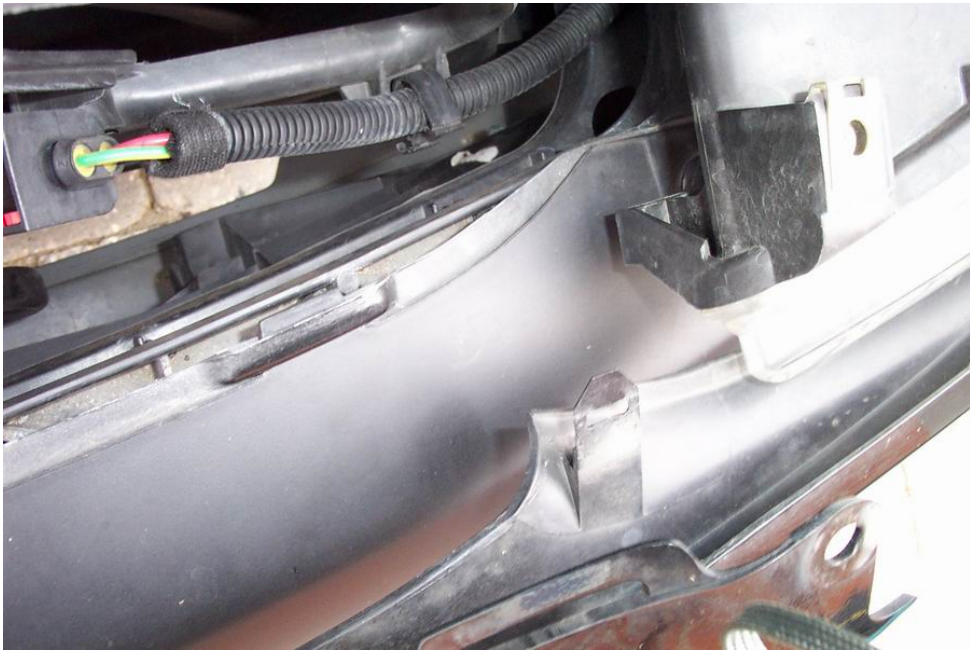

The remaining clips holding this piece to the headlights are sitting low in the corners. Push them one at the time downwards and release it from the headlight unit.

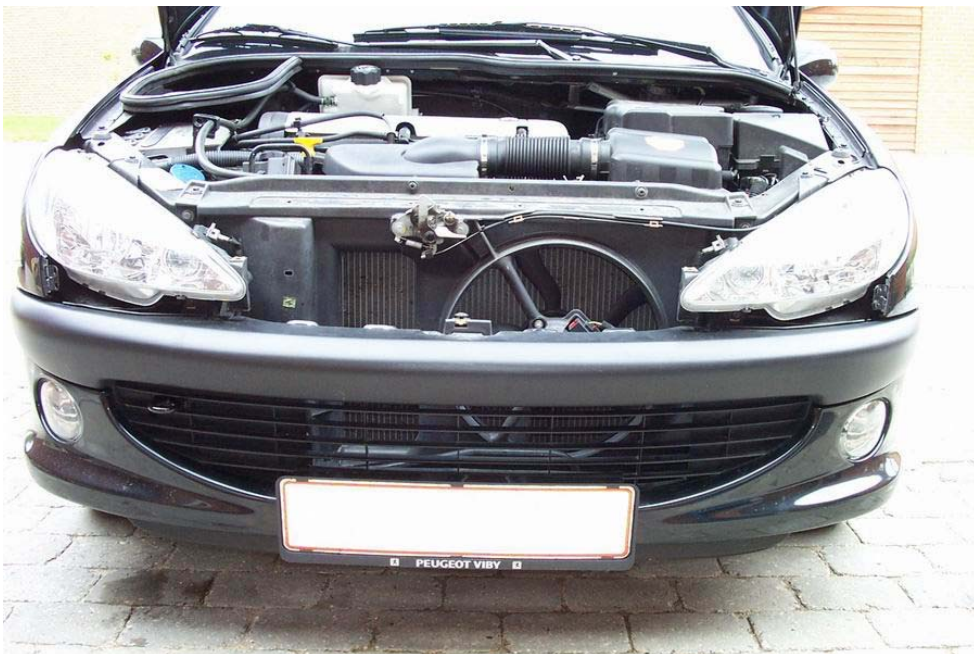

Now the front looks like this.

How to remove 206GTi front bumper (© PVL)



Now the M6 Torx30 bolts under the headlights have to be taken out. This is possible without removing the headlight units...



by using a Torx30 bit...

How to remove 206GTi front bumper (© PVL)

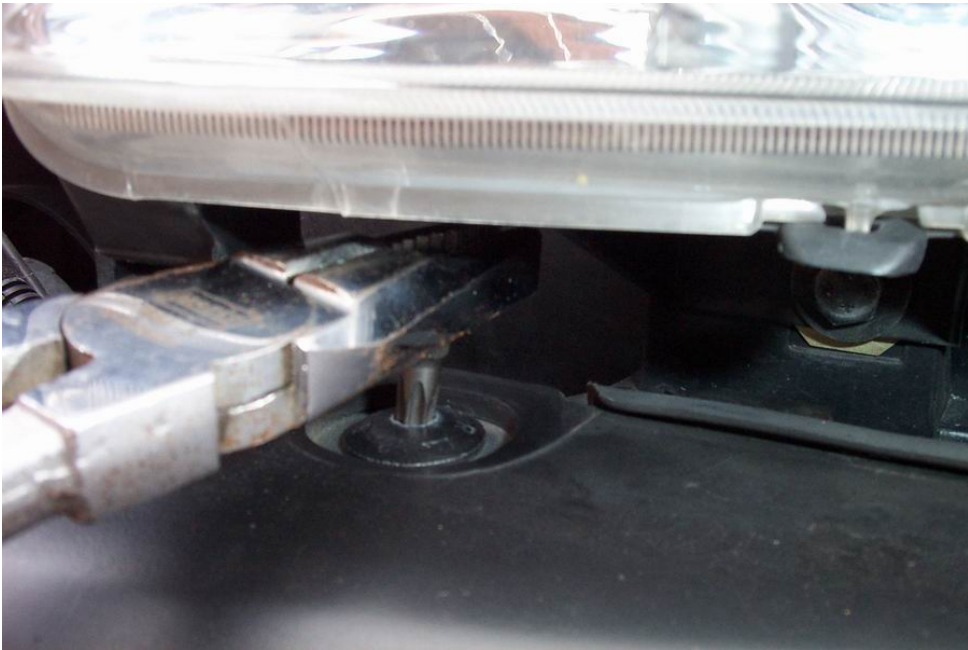

...and for instance a set of combination pliers. The bolts are normally not sitting very tight, so this will not be a big problem. After one turn the bolt will be freed enough to turn it out by hand. Mind you there are two, one on each side.



Crawl under the car and remove the two Torx20 parkers, positioned left and right of the spoiler...

How to remove 206GTi front bumper (© PVL)



...and remove the remaining two Torx20 parkers left and right around the corner, close to the front wheels.



Since you're still on the ground; remove the front inner wings (left and right) by taking out the mushroom clip (the same as from step 3) situated close to you in front of the front spring...

How to remove 206GTi front bumper (© PVL)



...and the other one which is positioned deeper in the wheel bay just to the left (when working on the left side of the car, of coarse)



Take the inner wings out.

How to remove 206GTi front bumper (© PVL)



Still sitting on the floor; remove the M6 nuts which are holding the bumper edges on it's place.



Take the connectors from the foglights...

How to remove 206GTi front bumper (© PVL)



...by pushing in the steel retaining clip.



We're almost there: remove at the underside of the bumper the two M6x20 bolts, which are connecting the bumper with the steel transverse chassis bar...

How to remove 206GTi front bumper (© PVL)



...pull the bumper edges down, out of the arches and call a mate and ask him to hold the bumper!



The last thing holding the bumper on its place is a Torx20x30 bolt positioned in the middle of the bumper, in-between the head lights, just left from the Torx20 bolt you loosened in step 9

How to remove 206GTi front bumper (© PVL)



Take the bumper off the car together with your mate each of you at one far corner and **mind the paintwork** while doing this. Now your car should look like this.



If one wants to take out the grill, put the bumper down on the grass (or something else soft and non-scratching) with the backside up. The grill is simply clipped on the bumper by means of several retraining clips, moulded in the bumper. It's fairly easy to take it off.

How to remove 206GTi front bumper (© PVL)



Support the bumper from the underside and put the new grill into place.



To put the bumper back, simply go in reverse order, minding the paint and noting that the front inner wings have to be slid back **under** the rear half of the inner wing. Keep also the markings in mind when you put the various nuts, bolts and parkers back, so all the items you removed will be bolted tight in the same position as they were. Then it looks like this...

How to remove 206GTi front bumper (© PVL)



...and like this in close up,

More HOW-TO's available at www.206gti.net including:

- What lights where
- Removing Door Trim
- DIY Oil Change
- Taking the Lower Console Apart
- Changing Licence Plate Lights
- Intake Modifications
- '04 Tweeter Change
- Changing Front Pads and Discs
- How to check the Throttle Cable
- How to Remove the outside mirror
- Inside the Key
- How to remove the air intake
- Changing your air filter
- DIY OEM Phone holder Install
- How to fix the buzzing at 2800rpm
- How to change the Aircon lights

NOTE: ALL instructions are undertaken at your own risk – 206gti.net nor the author of the "HOW-TO" do not take any responsibility for matters arising from the use of this document. We recommend that you seek professional assistance in performing any motor vehicle maintenance.