

Multi Technology System INC.

Company Profile



Best technology, automation systems, Quality and safety.

Solutions for Automation



To provide customers
excellent-quality
Products and service

To manufacture
best-quality products
that customers rely on

Table of Contents

1	GREETINGS
2	BRIEF HISTORY
3	COMPANY BROCHURE
4	M'Tech System Demo Staion
5	CUSTOMER
6	MAJOR ITEM
7	MAJOR PROJECTS
8	PURGE TESTING PROCEDURE
9	INSPECTION
10	QUALITY

Greetings



// TECHNOLOGIES INNOVATION

M.TECH SYSTEM INC.

The First step of control starts with the precise measurement of value.

Since it's establishment in 2002, MTECH has been engaged in manufacturing of the PLC & HMI System and Air Purge Panel.

We are realizing defect-free production through supplying and accurate and efficient system to various area industrial work places and the latest equipment

MTECH has developed it's own technology and quality to meet international standards and will continue to find new way for better the service to our customers. ALL of MTECH employees are committed to serve their customers with integrity and diligence. We will try it's utmost until it can solve problem in any place and anytime at the request of customers.

Thank you.

President Suck Chul KANG

BRIEF HISTORY

NOW

- Going to get The Certificate INNOBIZ
- Obtained The Certificate of R&D Center

2014

- M'TECH System Factory Extension
- Rockwell RcSI (AB PLC) Certificate

2012

- Samsung Total Certificate
- Headquarter has just acquired a new office for the extent and move

2009

- KGS Certificate for Technical Capability & Production Organization

2008

- SK Energy Certificate
- Venture Business Certificate

2006

- Obtained The Certificate of ISO 9001:2000

2002

- Established M Tech System INC.



2002 - NOW
MULTI TECHNOLOGY SYSTEM INC.



COMPANY BROCHURE

HEAD OFFICE

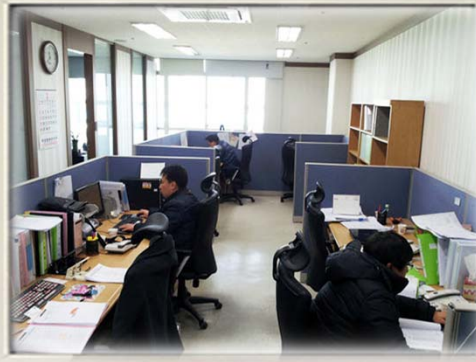

FACTORY



OFFICE

#904 101-Dong Digital-Empire II, 88,
Sinwon-ro, Yeongtong-Gu, Suwon-City,
Gyeonggi-Do, Korea

TEL : 82-31-695-6370~2
FAX : 82-31-695-6373

FACTORY

62-11, Dontanjiseong-ro 206 beon-gil,
Hwaseong-si, Gyeonggi-do, Korea

TEL : 82-31-236-1262
FAX : 82-31-236-1273



OFFICE

#904 101-Dong Digital-Empire II, 88,
Sinwon-ro, Yeongtong-Gu, Suwon-City,
Gyeonggi-Do, Korea

TEL : 82-31-695-6370~2
FAX : 82-31-695-6373

FACTORY

62-11, Dontanjiseong-ro 206 beon-gil,
Hwaseong-si, Gyeonggi-do, Korea

TEL : 82-31-236-1262
FAX : 82-31-236-1273



COMPANY BROCHURE



CONFERENCE ROOM

The conference room is provided for your convenience and are equipped with everything they could to make our customers feel welcome.

Mtech System Demo Station

PLC & HMI System Overview

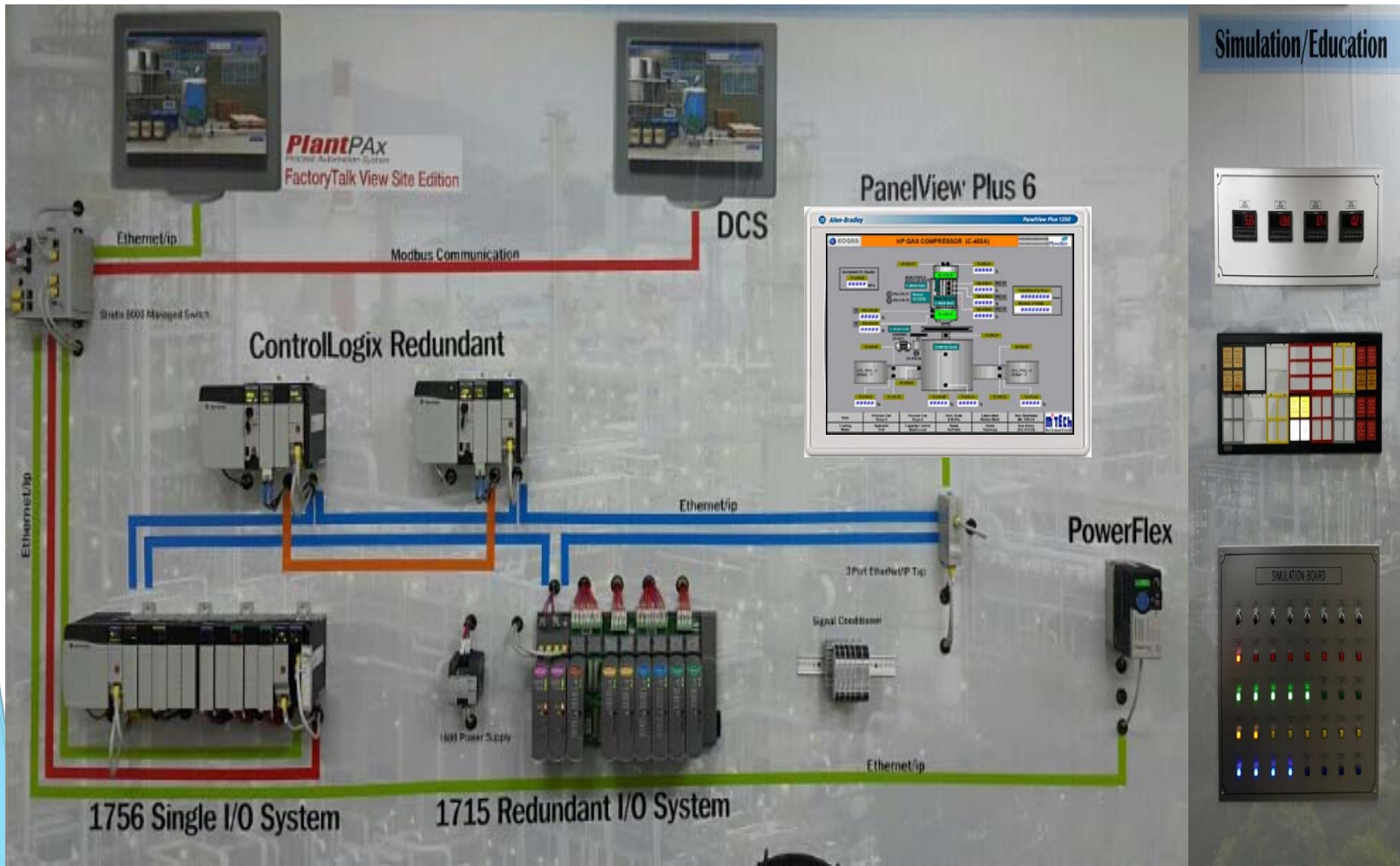

DEMO ROOM

We are equipped with the best equipment that can test the quality and performance.

We constantly research and development for sustainable growth, and can immediately test at any time.

CUSTOMER

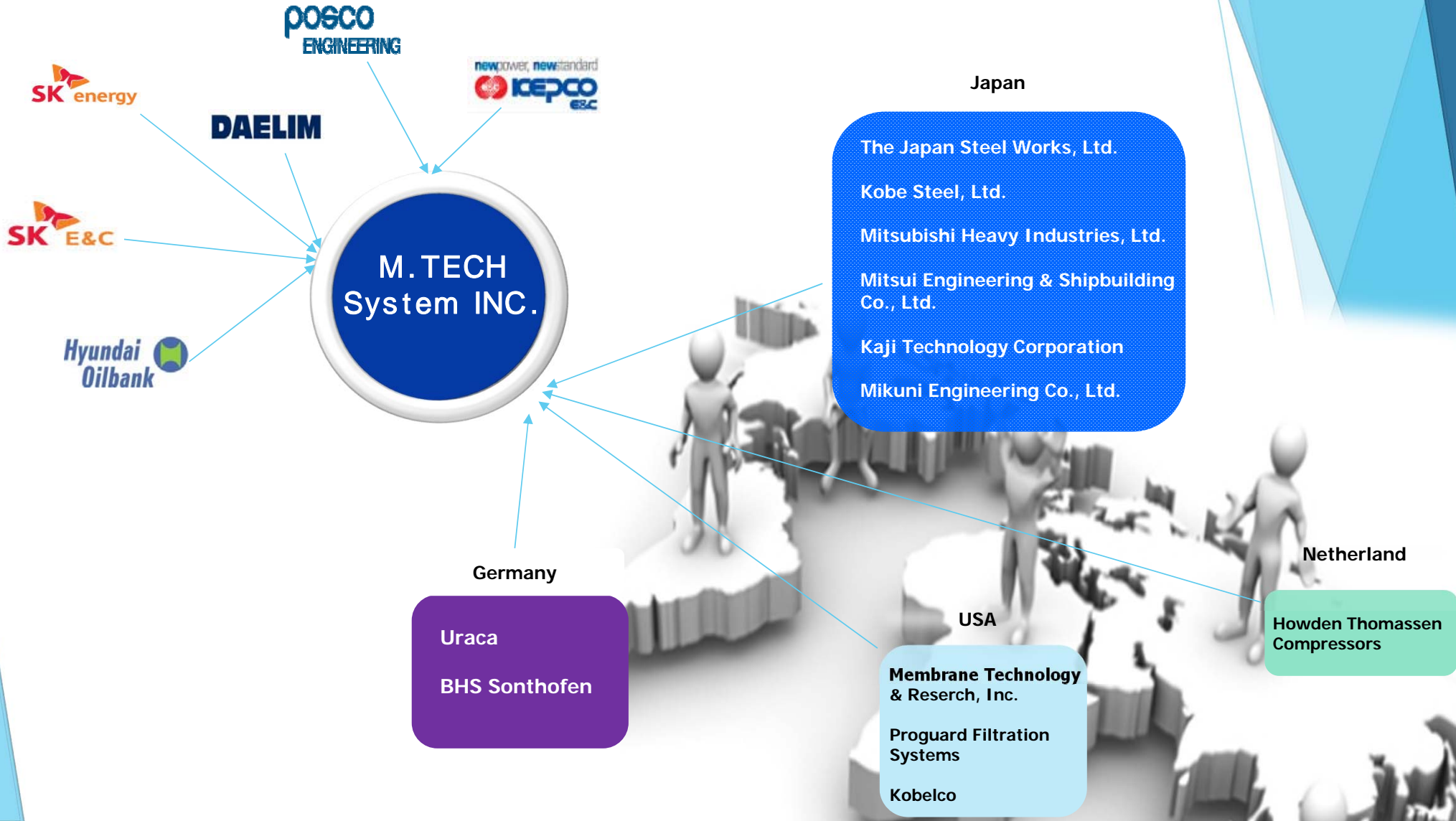

MAJOR ITEM

Local Control Panel

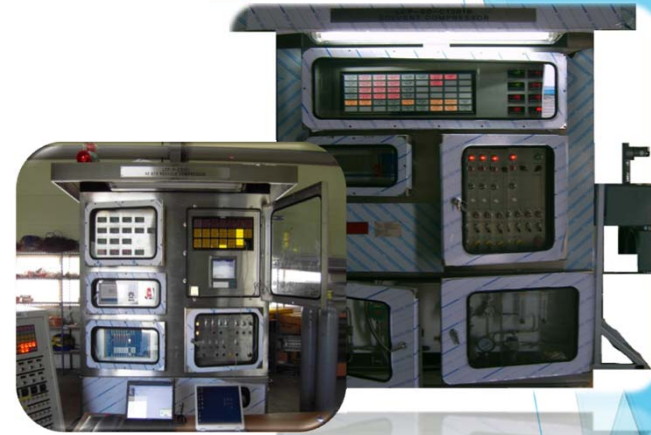
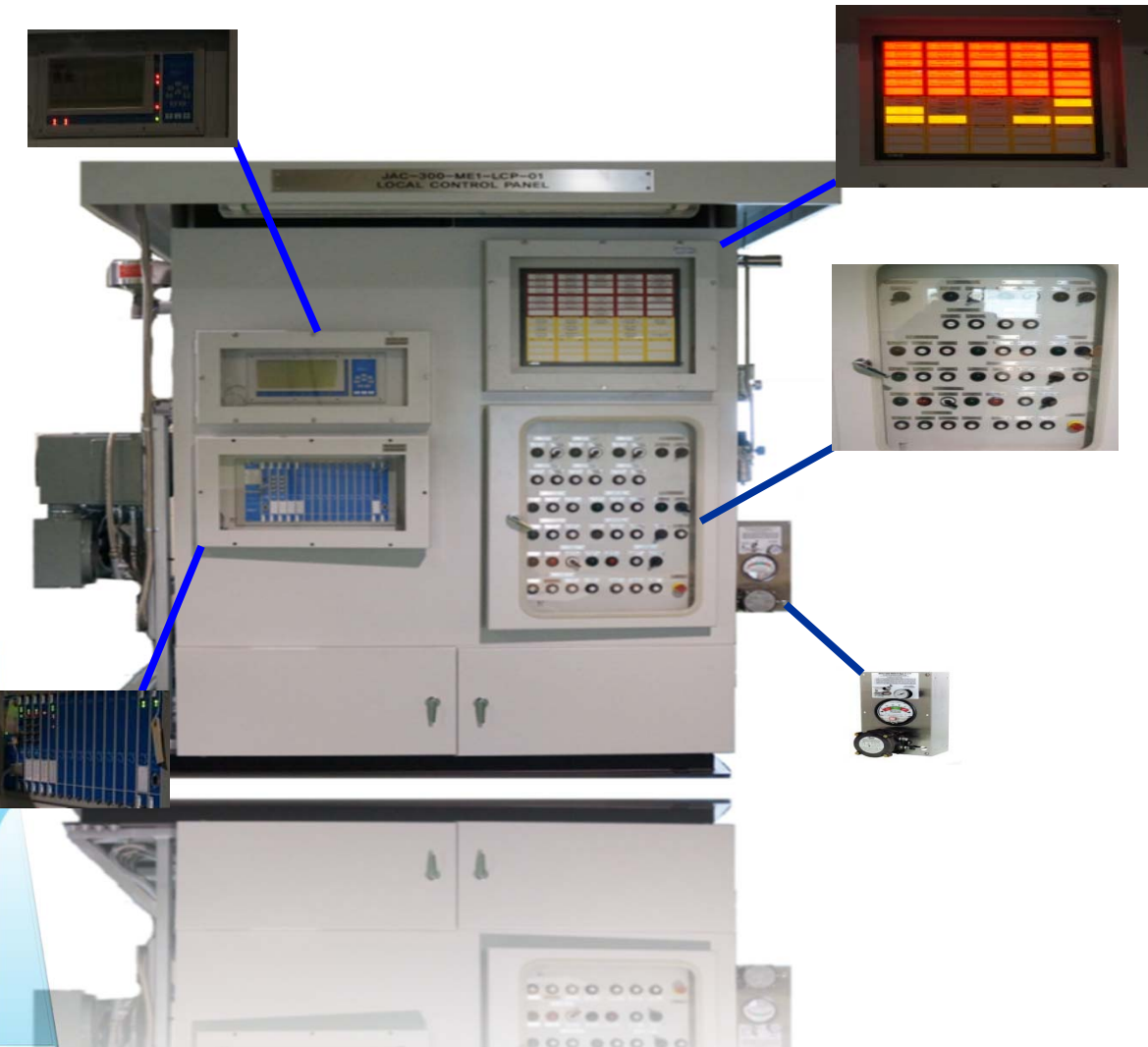

Filter System

Recycle Compressor

Make-Up Compressor

Off Gas Compressor

Fuel Gas Compressor

Gas Blower

Hydrogen Recovery Unit

Water Injection Pump

MAJOR ITEM

HMI System



Filter System

Recycle Compressor

Make-Up Compressor

Off Gas Compressor

Fuel Gas Compressor

Gas Blower

Hydrogen Recovery Unit

Water Injection Pump

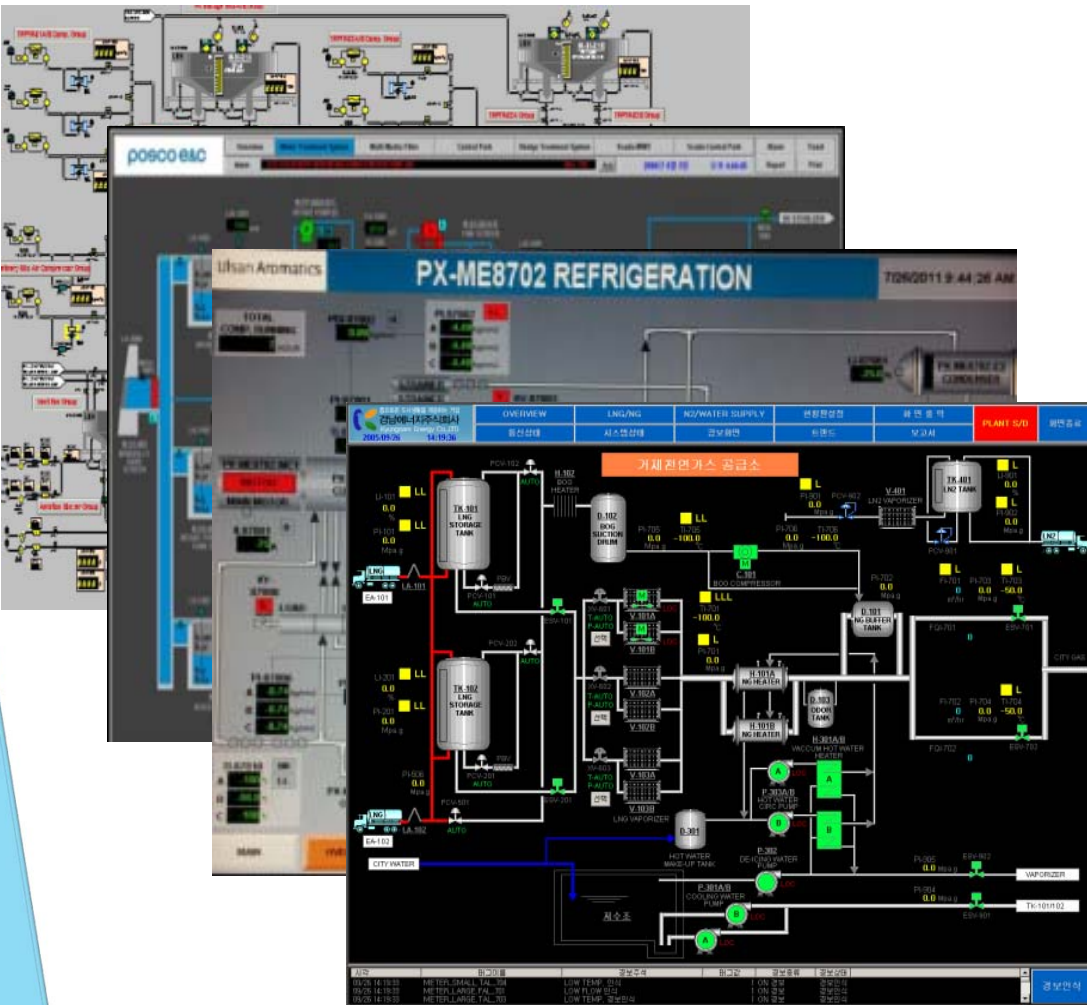

MAJOR ITEM

PLC System

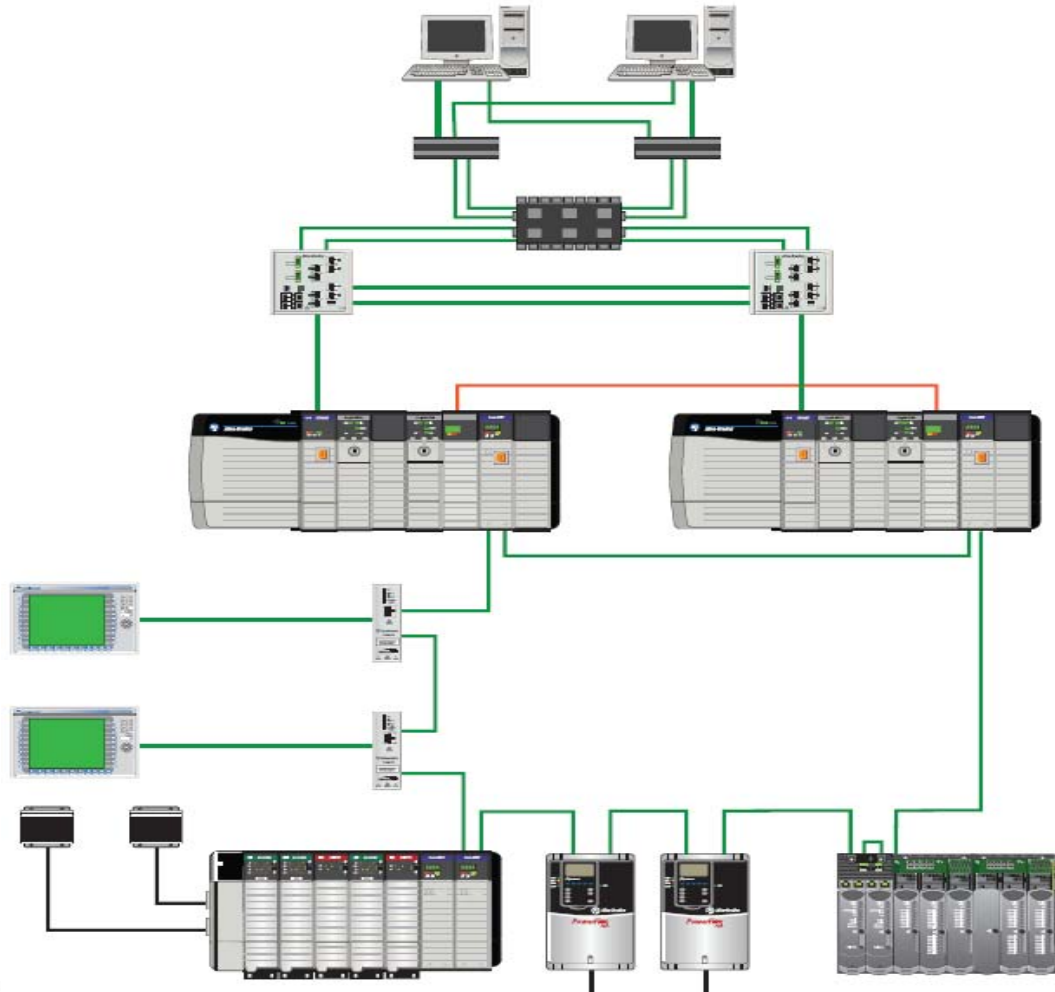

Filter System

Recycle Compressor

Make-Up Compressor

Off Gas Compressor

Fuel Gas Compressor

Gas Blower

Hydrogen Recovery Unit

Water Injection Pump

MAJOR ITEM

Purge / Pressurization System

Package Control Panel with Air Purge System

1. Feed Filter
2. Candle Filter
3. Recycle Compressor
4. Make-Up Compressor
5. OFF GAS Compressor
6. MAIN GAS BLOWER
7. Hydrogen Recovery Unit
8. Water Injection Pump

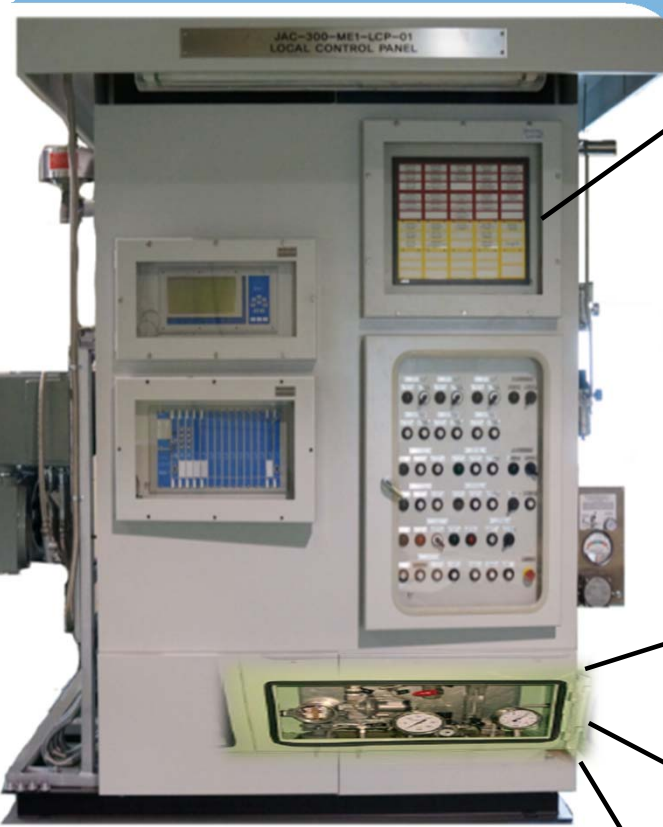

Safety glass



Explosion Proof Switches

Purge System

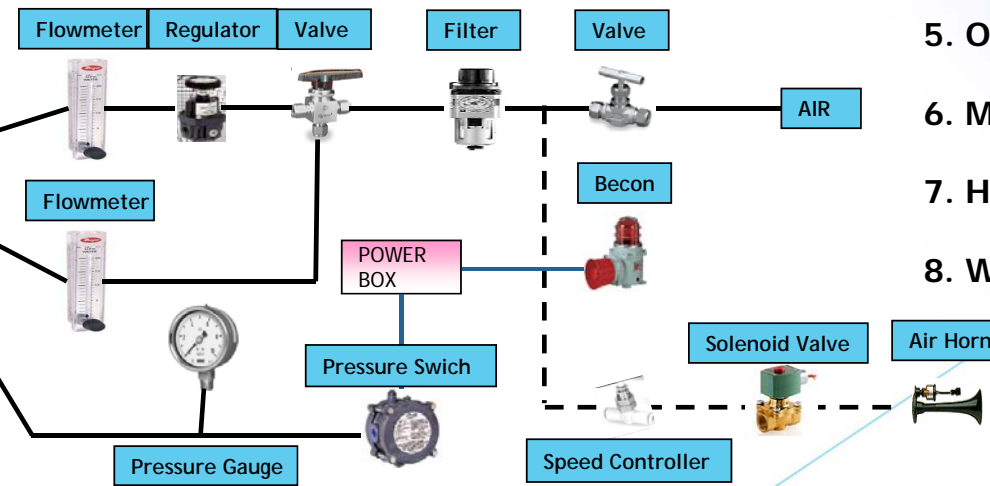

Flowmeter

Regulator

Valve

Filter

Valve

AIR

Flowmeter

Becon

POWER BOX

Pressure Switch

Pressure Gauge

Speed Controller

Solenoid Valve

Air Horn

MAJOR PROJECT

Hyundai Oil Bank- #2 HOU Project

PROJECT	ITEM NAME	Q'TY	SUPPLIER	NOTE
#2 HOU PROJECT (#2 HOU PROJECT full PLC's 90 professional orders)	FEED FILTER	8	PROGUARD (USA)	
	CANDLE FILTER	1	BHS (GERMANY)	
	PDS H2 RECYCLE COMPRESSOR	2	MIKUNI (JAPAN)	
	MAKE-UP COMPRESSOR	2	MIKUNI (JAPAN)	
	HYDROGEN MAKE-UP COMPRESSOR	4	HTC (NETHERLAND)	
	OFF GAS COMPRESSOR	2	HTC (NETHERLAND)	
	MAIN GAS BLOWER	1	INO (KOREA)	
	HYDROGEN RECOVERY UNIT	1	MTR (USA)	



MAJOR PROJECT

SK Innovation – New PX Project

PROJECT	ITEM NAME	Q'TY	SUPPLIER	NOTE
NEW PX PROJECT (SK NEW PX PROJECT full PLC's 80~90 professional orders)	RECIPROCATING COMPRESSOR	2	MES (JAPAN)	
	REFRIGERATION PACKAGE	3	YUSUNG ENGINEERING (KOREA)	
	FLARE STACK CONTROL PANEL	1	JOHN ZINK HAMWORTHY COMBUSTION (KOREA)	



MAJOR PROJECT

SK Innovation – V Project

PROJECT	ITEM NAME	Q'TY	SUPPLIER	NOTE
V PROJECT (SK V PROJECT full PLC's 80~90 professional orders)	RECYCLE COMPRESSOR	2	MES (JAPAN)	
	OFF-GAS COMPRESSOR	2	MES (JAPAN)	
	MAKE-UP COMPRESSOR	2	MES (JAPAN)	
	RECYCLE COMPRESSOR	2	MES (JAPAN)	
	NET GAS COMPRESSOR	2	MES (JAPAN)	
	REFRIGERATION PACKAGE	2	YUSUNG ENGINEERING (KOREA)	
	REFRIGERATION PACKAGE	1	MYCOM(KOREA)	
	FLARE STACK CONTROL PANEL	1	JOHN ZINK HAMWORTHY COMBUSTION (KOREA)	
	VIBRATION MONITERING SYSTEM	1	HYUNDAI ENGINEERIGN & CONSTRUCTION (KOREA)	

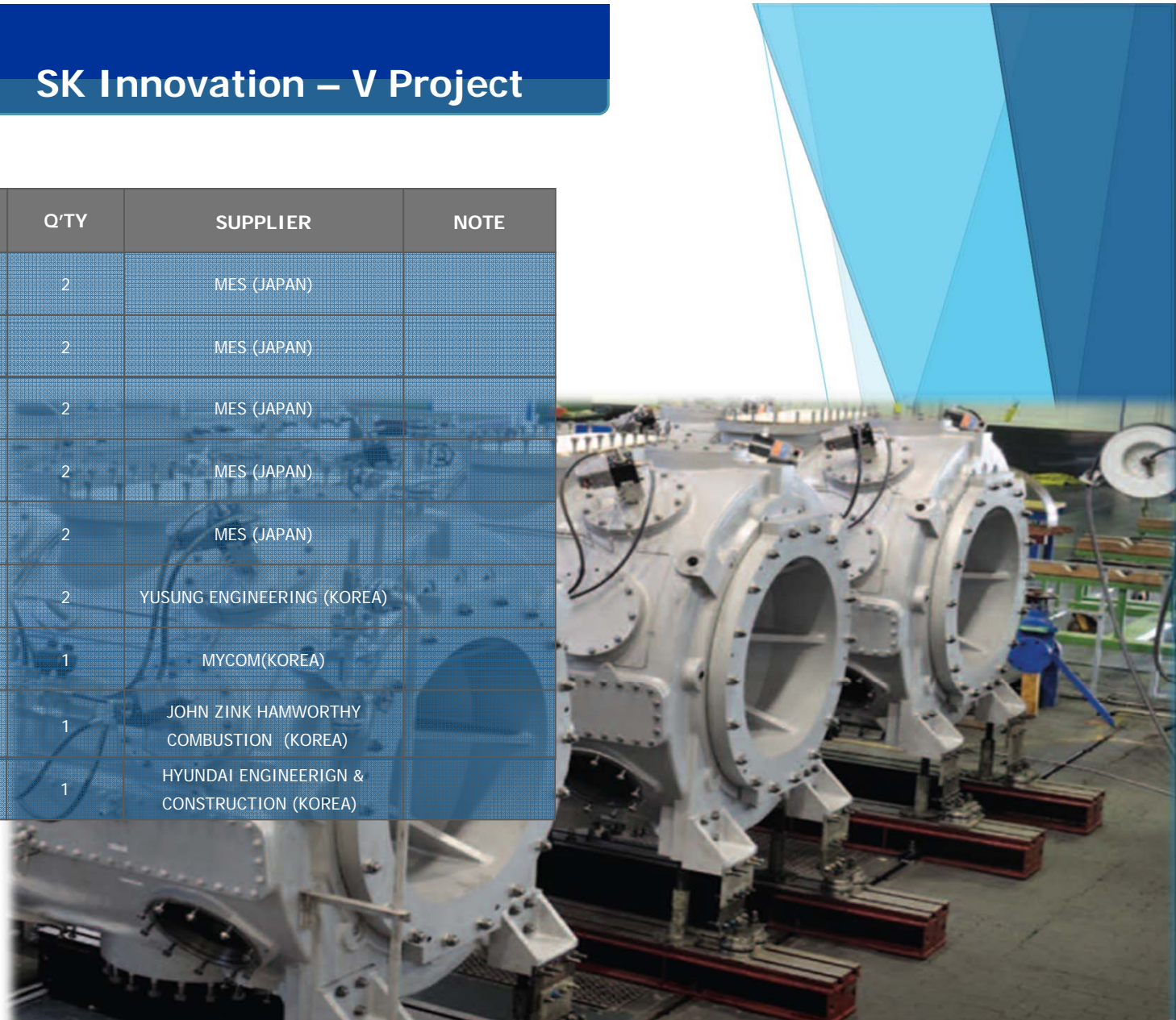

MAJOR PROJECT

SK Ulsan PDH Project

PROJECT	ITEM NAME	Q'TY	SUPPLIER	NOTE
SK Ulsan PDH Project	FEED GAS COMPRESSOR	4	MES (JAPAN)	AB PLC (HMI)
	GAS FILTER	3	MHI (JAPAN)	AB PLC (HMI)
	Reactor Valve Control System	7	EMERSON(KOREA)	AB PLC (HMI)
	Floating Oil Skimmer Package	1	DS21(KOREA)	-

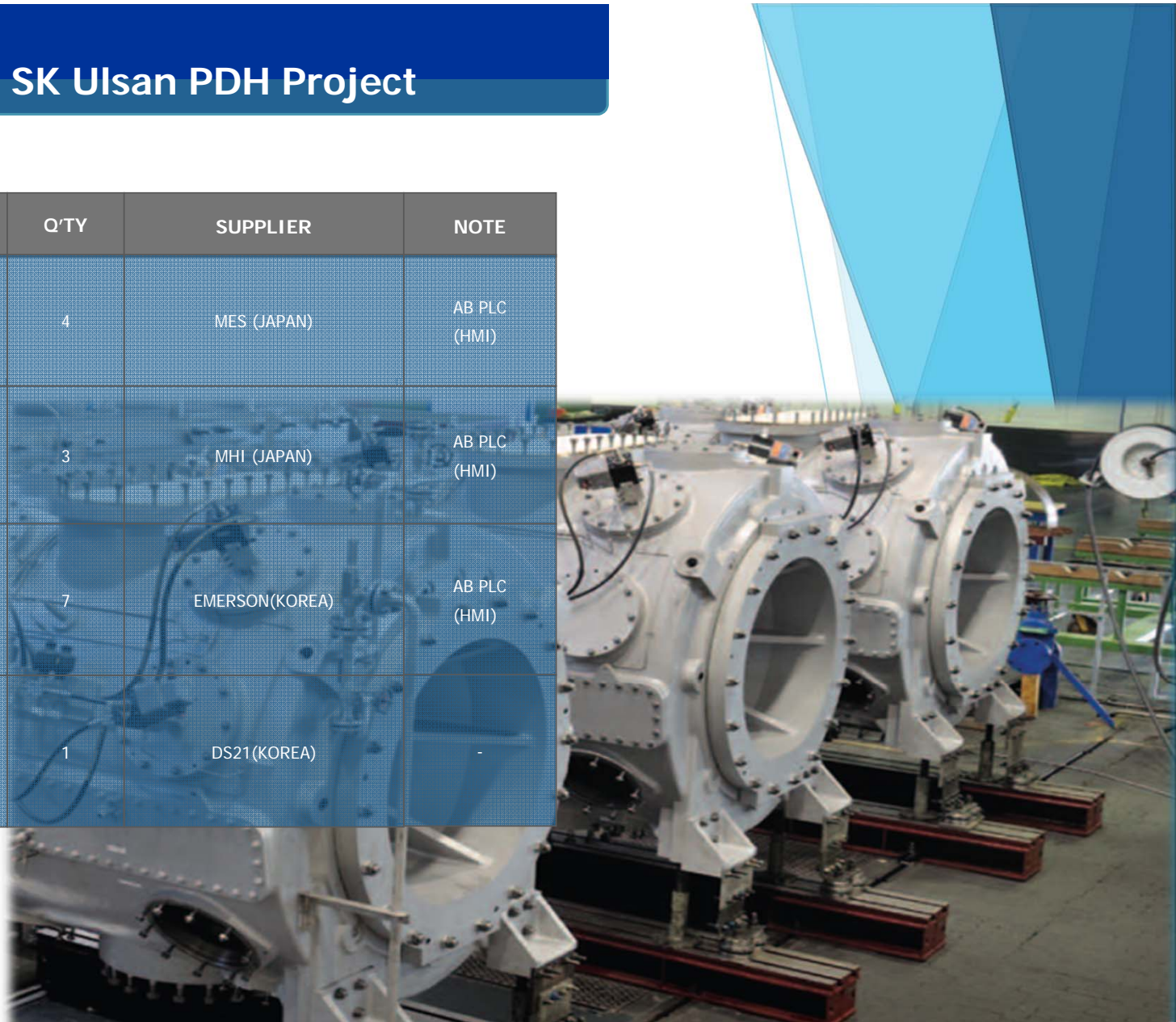

Major Experience List

PLC & HMI System

Date	Project	Item	Owner
2002	Gulpochun Valva Station Scada System	GE Fanuc PLC (90-30)	Daehan Oil Pipeline Co. Ltd.
2003	Songdo New City North Gate Control System	LS PLC (Glofa), HMI	Incheon City
2003	Goksung Station Scada System	AB PLC (PLC-5)	Daehan Oil Pipeline Co. Ltd.
2003	Coal Dosing System	LS PLC (Glofa)	LafargeHalla Cement
2004	Samchonpo Unit 5,6 ASH Handling System	Modicon PLC (Quantum), HMI	Korea South-East Power Co. Ltd.
2005	Methanex Methanol TK Upgrade-Yeosu	LS PLC (Glofa), HMI	Yeosu Tank Terminal
2005	Ggeoje Natural Gas Service Plant	LS PLC (Glofa), HMI	Kyungnam Energy Co. Ltd.
2006	Samchonpo Small Power Plant	AB PLC (Contrologix), HMI	Korea South-East Power Co. Ltd.
2007	Youngheung Unit 3,4 ASH Refinery System	AB PLC (Contrologix), HMI	Korea South-East Power Co. Ltd.
2007	Youngheung Unit 3,4 ASH Shipping System	AB PLC (Contrologix), HMI	Korea South-East Power Co. Ltd.
2008	No.2 HNH Project	AB PLC (Contrologix), HMI	SK Energy
2008	Donghae Unit 1,2 Imported Coal Unloading	AB PLC (Contrologix), HMI	Korea East-West Power Co. Ltd.
2009	New Songdo City Central Part (SeaWater Intake)	AB PLC (Contrologix), HMI	Incheon City
2009	Incheon LNG Combined Power Plant No.5~6-HVAC	AB PLC (Contrologix), HMI	POSCO Power

Major Experience List

PLC & HMI System

Date	Project	Item	Owner
2010	Incheon LNG Combined Power Plant No.5~6-Waste Water	AB PLC (Contrologix), HMI	POSCO Power
2010	Gwangyang off-gas combined power Plant - Seawater	AB PLC (Contrologix), HMI	POSCO Power
2010	Kang-dong district collective energy supply facilities construction	AB PLC (Contrologix), HMI	Daehan City Gas Co., Ltd.
2011	SMB PILOT CONSTRUCTION(PLC & HMI PART)	AB PLC (Contrologix), HMI	SK Energy
2011	Sihwa dyeing using renewable energy supply business	AB PLC (Contrologix), HMI	KOREA INDUSTRIAL COMPLEX CORP
2011	Bundang Absorption Heat Pump System ESCO	LS PLC (XGT), HMI	KOREA SOUTH -EAST POWER
2011	Ilsan Absorption Heat Pump System ESCO	LS PLC (XGT), HMI	KOREA EAST-WEST POWER
2012	SUR IPP PROJECT	AB PLC (Contrologix), HMI	Phoenix POWER COMPANY
2012	NAC Electric Power #3 Plant 2B3T PLC System	AB PLC (Contrologix), HMI	SK Energy
2012	NAC Electric Power #3 Plant RO PLC System	AB PLC (Contrologix), HMI	SK Energy
2012	JAC CCR Project / FAR Control Panel	AB PLC (Contrologix), HMI	SK E&C / JAC
2012	Dangjin Terminal Unit 3,4	AB PLC (Contrologix), HMI	Power Engineering / Korea East-West Power
2013	HCC ORANGE PROJECT / RCP FOR CVD OFF GAS COMPRESSOR	Siemens PLC, HMI	Howden Thomassen Compressors / Hanhwa
2013	The 2nd Pyeong Taek Combined Cycle Power Plant	AB PLC (Contrologix), HMI	KOBELCO USA. / Korea Western Power
2013	Pocheon LNG Power Plant	AB PLC (Contrologix), HMI	KOBELCO USA. / Pocheon Power

Major Experience List

Air Purge Panel

Date	Project	Item	Contract / Client
2004	PP Project	Hydrogen Compressor	Kaji Technology Corporation / SK Corp.
2005	GE Project – No.4&5 M04	Reciprocating Compressor	Mitsui Engineering & Shipbuilding / SK Corp.
2005	GE Project – GDS	Reciprocating Compressor	Mitsui Engineering & Shipbuilding / SK Corp.
2005	HOU Project	Reactor Feed Pump	Nigata Worthington / SK Corp.
2005	FCC Project	Replacement of #2 HP-C2105 Emg' Compressor	Howden / SK Corp.
2005	FCC Project	Replacement of RC-C4901 Merox Air Compressor	Airdyne / SK Corp.
2006	NEP Debottleneck Project	Butadieme Gas Compressor	Kobe Steel, Ltd. / SK Corp.
2007	LG Chem. Revamping Project	Butadieme Gas Compressor	Kobe Steel, Ltd. / LG Chem
2007	#1 SRU Project	Local Control Panel	SKEC / SK Corp.
2007	HOU Project	VRDS_Pump Governor Control System	Power Engineering / SK Corp.
2007	New FCC Project	Hydrogen Recycle Compressor	Mitsui Engineering & Shipbuilding / SK Energy
2007	New FCC Project	Make-Up Compressor	Mitsui Engineering & Shipbuilding / SK Energy
2007	New FCC Project	Water Injection Pump	Uraca / SK Energy
2007	HPPO Project	C3=Compressor	The Japan Steel Works, Ltd / SKC

Major Experience List

Air Purge Panel

Date	Project	Item	Owner
2007	New FCC Project	Hydrogen Recovery SKID	Membrane Technology & Research, Inc. / SK Energy
2007	New FCC Project	Spent Catalyst Handling System	Jeio Co., Ltd. / SK Energy
2007	New FCC Project	Air Heater Package	Hanyang Industry Co., Ltd. / SK Energy
2007	New FCC Project	Incinerator Package	Hanyang Industry Co., Ltd. / SK Energy
2007	New FCC Project	Thermal Reactor	Hanyang Industry Co., Ltd. / SK Energy
2007	New FCC Project	Emergency Hydrogen Compressor	Kaji Technology Corporation / SK Energy
2007	New FCC Project	Co Boiler	Mitsubishi Heavy Industries, Ltd / SK Energy
2008	SM Revamping Project	Vent Gas Compressor	Kobe Steel, Ltd. / Lotte Daesan
2008	PE 290,000 T/Yr Plant	Vent Recovery Compressor	The Japan Steel Works, Ltd / Lotte Daesan Petro
2009	SDA Project	Solvent Compressor	Mitsui Engineering & Shipbuilding . / SK Energy
2009	EPDM Debottlenecking Project	ReCycle Monomer 2nd Compressor	Kobe Steel, Ltd. / SK Energy
2009	#2 BTX Project	Compressor (P-C3101) Turbine Drive	SK Energy / SK Energy
2010	HCC (OBL) Project	H2 Rich Gas Compressor	Mitsui Eng. / SK Energy
2010	HDO #2 HOU Project	CANDLE FILTER	BHS / Hyundai Oil Bank
2010	HDO #2 HOU Project	PDS H2 Recycle Compressor	Mikuni Eng. / Hyundai Oil Bank

Major Experience List

Air Purge Panel

Date	Project	Item	Contract / Client
2010	HDO #2 HOU Project	Make-Up Compressor	Mikuni Eng. / Hyundai Oil Bank
2010	HDO #2 HOU Project	HYDROGEN MAKE-UP COMPRESSOR	Thomassen Compressor System / Hyundai Oilbank
2010	HDO #2 HOU Project	OFF GAS COMPRESSOR	Thomassen Compressor System / Hyundai Oilbank
2010	HDO #2 HOU Project	MAIN GAS BLOWER	INO Technologies INC/ Hyundai Oilbank
2010	HDO #2 HOU Project	HYDROGEN RECOVERY UNIT	Membrane Technology & Research/ Hyundai Oilbank
2011	No.4 SRP FA3511, 3611 LCP	Air Purge Panel	SK ENERGY / SK Energy
2011	P2(P4PE) Project	LCP for PK-4301 Recycle Gas Compressor	JSW / Honam Petrochemical
2011	SK H-Project	INSTRUMENT AIR DRYER	SEYANG / SK Energy
2011	SK H-Project	HEATER LOCAL PANEL & IGNITION TRANSFORMER BOX	SAMWON / SK Energy
2011	SK H-Project	RECYCLE GAS COMPRESSOR	Howden Thomassen Compressors / SK Energy
2012	SK H-Project	HYDROGEN RECOVERY UNIT	Membrane Technology & Research / SK Energy
2012	SK H-Project	BMS LOCAL CONTROL PANEL	FORECO / SK Energy
2012	Jurong Aromatic Complex Project	BN MONITOR PANEL	UOP (G-PEM Engineers, Inc) / JAC
2012	SK H-Project	MAKE-UP GAS COMPRESSOR	Mitsui Engineering Shipbuilding Co. Ltd / SK Energy
2012	HDO CH4 Project	CH4 RICH GAS COMPRESSOR	Howden Thomassen Compressors / SK Energy

Major Experience List

Air Purge Panel

Date	Project	Item	Contract / Client
2012	Jurong Aromatic Complex Project	Jurong Recovery Plus FAB / Local Control Panel	UOP (G-PEM Engineers, Inc) / JAC
2012	Jurong Aromatic Complex Project	FAR CONTROL PANEL	HISCO / JAC
2012	Jurong Aromatic Complex Project	REFRIGERATION PACKAGE	MYCOM / JAC
2012	UT Boiler Panel Replacement	UT BOILER PANEL	SAMSUNG TOTAL
2013	HCC ORANGE PROJECT	RCP FOR CVD OFF GAS COMPRESSOR	Howden Thomassen Compressors / HANHWA
2013	H-Project	LOCAL CONTROL PANEL FOR FEED FILTER	SKEC / SK Innovation
2013	Petron Bataan Refinery	LOCAL CONTROL PANEL	KAJI TECHNOLOGY CORPORATION
2013	Hydropocket Control Panel	Hydropocket Control Panel	Howden Thomassen Compressors / SK Innovation
2013	No.2 FCC Revamp Project	LOCAL CONTROL PANEL	MITSUBISHI / SK Innovation
2013	LG CHEM.	EXTRUDER SYSTEM	FA-men / LG Chemical
2013	JG Summit Petrochemical Corp	REMOTE CONTROL PANEL	Kaji Tech / JG Summit Petrochemical Corp.
2013	New PX Project	Reciprocating Compressor	Mitsuiengineering and Shipbuilding / SK Innovation
2013	V - Project	Recycle Compressor	Mitsuiengineering and Shipbuilding / SK Innovation
2013	V - Project	Make-up Compressor	Mitsuiengineering and Shipbuilding / SK Innovation
2013	V - Project	Recycle Compressor	Mitsuiengineering and Shipbuilding / SK Innovation

Major Experience List

Air Purge Panel

Date	Project	Item	Contract / Client
2013	V - Project	Net Gas Compressor	Mitsuiengineering and Shipbuilding / SK Innovation
2013	JAC Project	Local control Panel	SK E&C/ JAC
2013	JAC Project	Motor Control Panel	SK E&C/ JAC
2013	#2 NHT Expansion Project	Local control Panel	Mitsuiengineering and Shipbuilding / SK Innovation
2013	New PX Project	Refrigeration Package	Yusung Engineering / SK Innovation
2013	V - Project	Refrigeration Package	Yusung Engineering / SK Innovation
2013	Nexlene Project	Local control Panel	DAEGA POWDER SYSTEM / SK Innovation
2013	New PX Project	Refrigeration Package	MYCOM / SK Innovation
2013	Samsung Total	EXTRUDER SYSTEM	FA-men / Samsung Total
2013	Samcheok LNG Terminal Project	Local control Panel	Howden Thomassen Compressors / KOGAS
2013	New PX Project	Local control Panel	John Zink Hamworthy Combustion / SK Innovation
2013	V - Project	Local control Panel	John Zink Hamworthy Combustion / SK Innovation
2013	V - Project	VMS Panel	Hyundai E&C / SK Innovation
2014	No.1 RFCC Catalyst MU System Upgrade Project	Local Control Panel	Intercat Equipment, Inc.
2014	OCI P4 Project	Local Control Panel	Howden Thomassen Compressors

Purge Testing Procedure

Product Check



Dilution Test



Temperature Measurement And Alarm Test



Inspection

Specification & Visual Check



Product Function Test

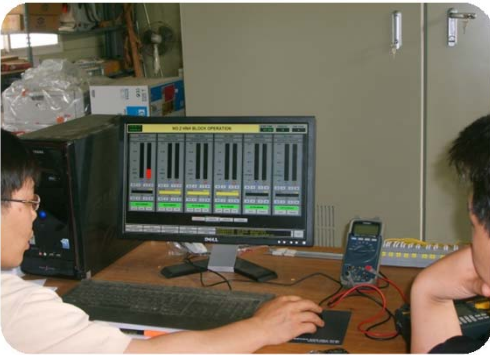

Quality

Quality Procedures

INQUIRY

- ESTIMATE REVIEW REPORT
- QUOTATION

DESIGN

- DESIGN REVIEW REPORT
- DETAILED DESIGN
- REVIEW REPORT
- DESIGN CHANGES

MANUFACTURE

- CUSTOMER SUPPLIES LIST
- IMPORT INSPECTION

INSPECTION

- FACTORY ACCEPTANCE TEST
- CLIENT, CONSTRUCT WITNESS INSPECTION
- DELIVERY
- A/S

계약 검토서		계약	일부	일괄
계약번호				
계약명				
계약 일자				
계약 기간				
계약 내용	시공, 설계, 시공감리, 유지관리, VDR, VDR, 유지, 시공, A/S 등			
계약 대상				
계약 금액				
계약 조건				
계약 기타				
계약 담당				
계약 승인				
계약 일자				
계약 장소				
계약 기타				

설계변경요구 및 통보서	
변경번호	
변경일자	
변경내역	
변경이유	
변경부서	
변경인	
변경일자	
변경장소	
변경기타	

고객제공품 관리대장	
고객명	
제공품명	
제공일자	
제공장소	
제공인	
제공일자	
제공장소	
제공기타	

INSPECTION TEST PROCEDURE			
PROJECT		JOB No. (C/F)	
		JOB No. (C/F)	
		Doc. No.	
		Revision No.	
		Rev. No.	
		PAGE	2 OF 3
INSPECTION ITEM	DESCRIPTION OF INSPECTION	JUDGMENT STANDARDS	REMARK
1. Final Inspection	Final Inspection	Acceptance	
2. Material Inspection	Material Inspection	Acceptance	
3. Dimensional Inspection	Dimensional Inspection	Acceptance	

M Tech System Quality

- To provide customers excellent-quality products and service
- To manufacture best quality products that customers rely on