

# BIONICLE

FERO &  
SKIRTMIX



Ages/edades

**8-16**

**8990**





1

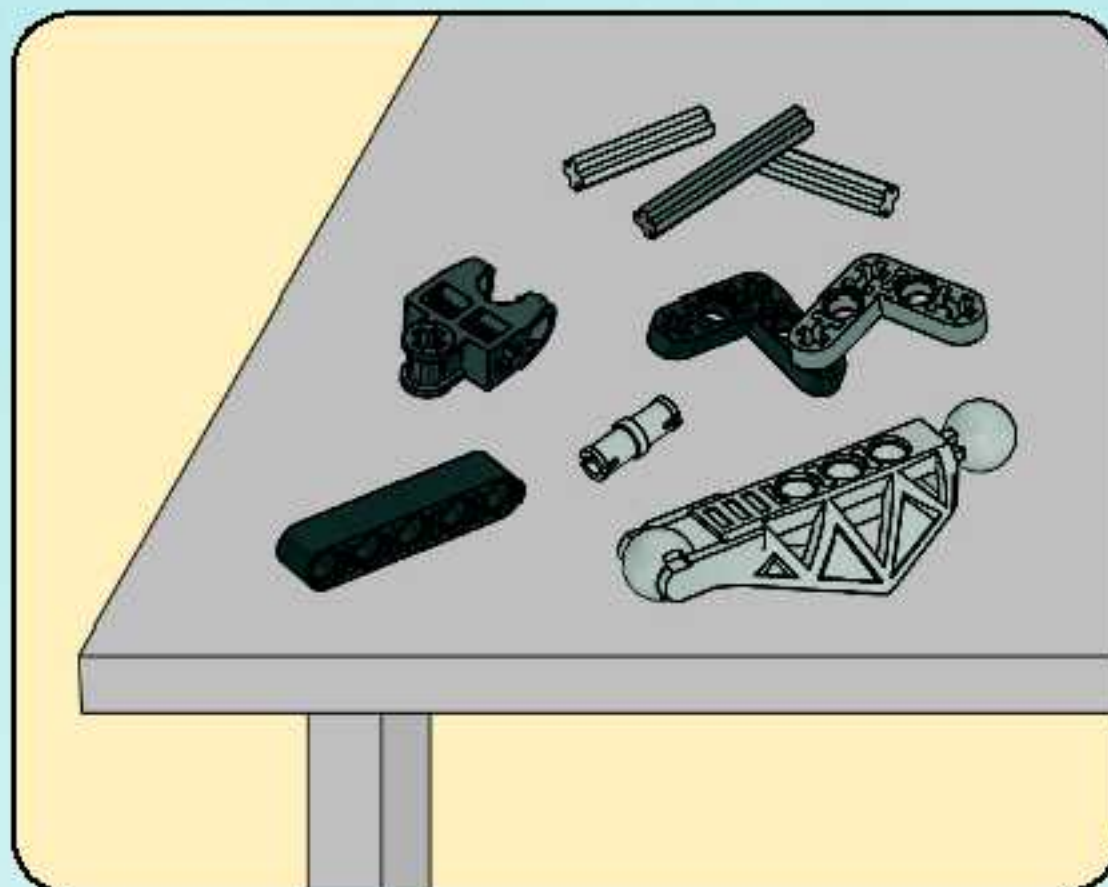

2

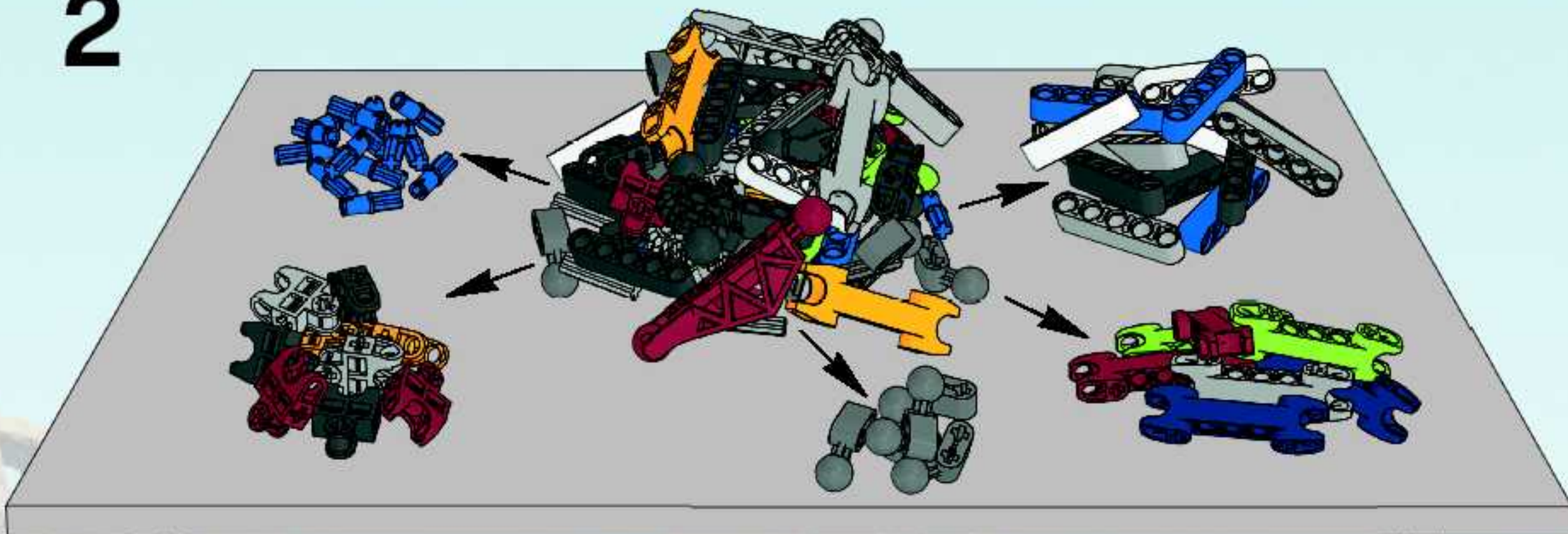

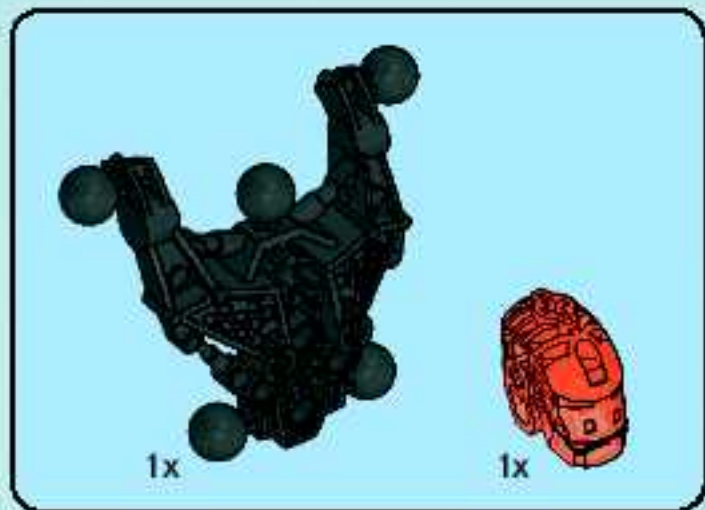

1

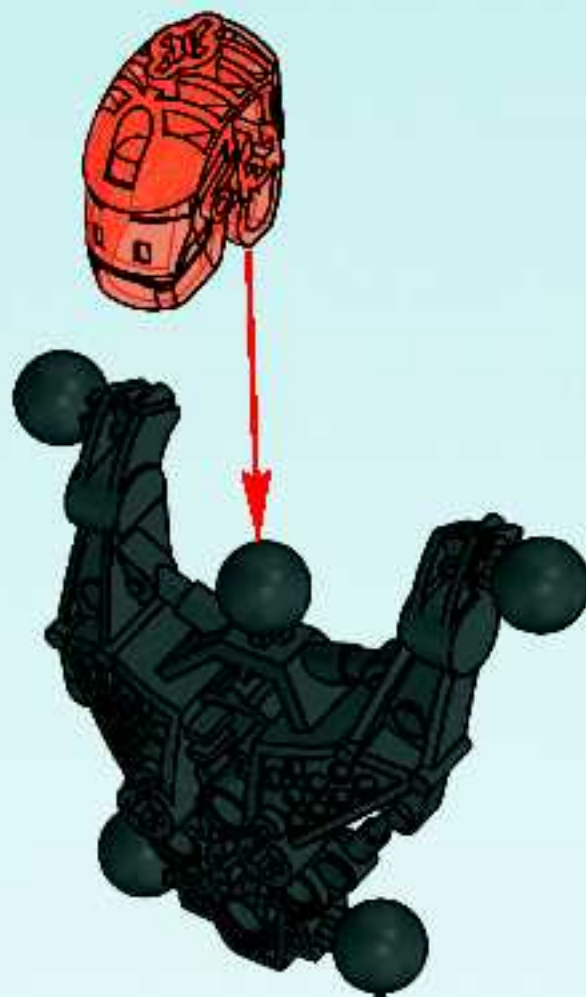



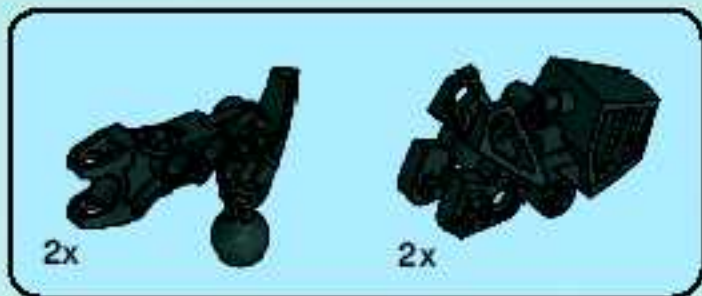

2

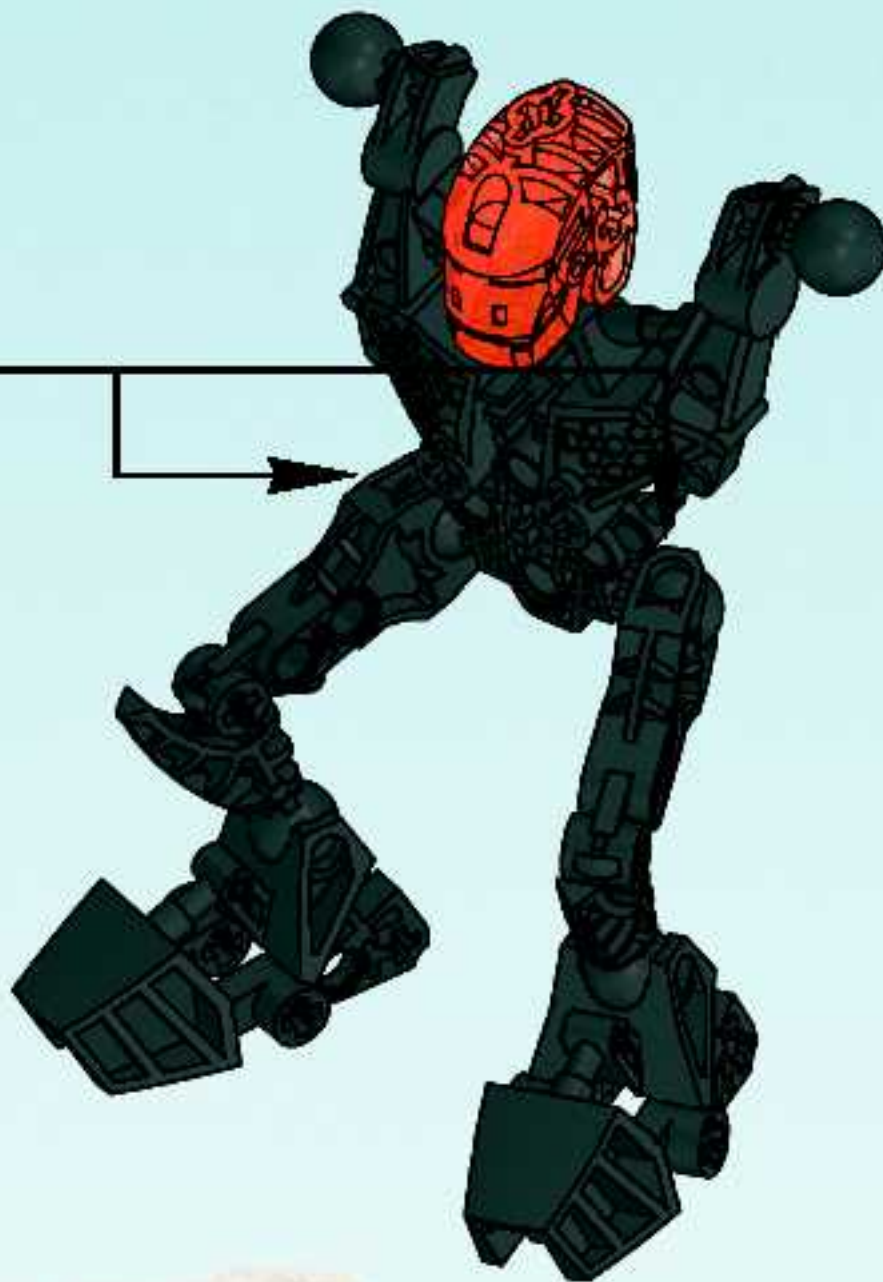
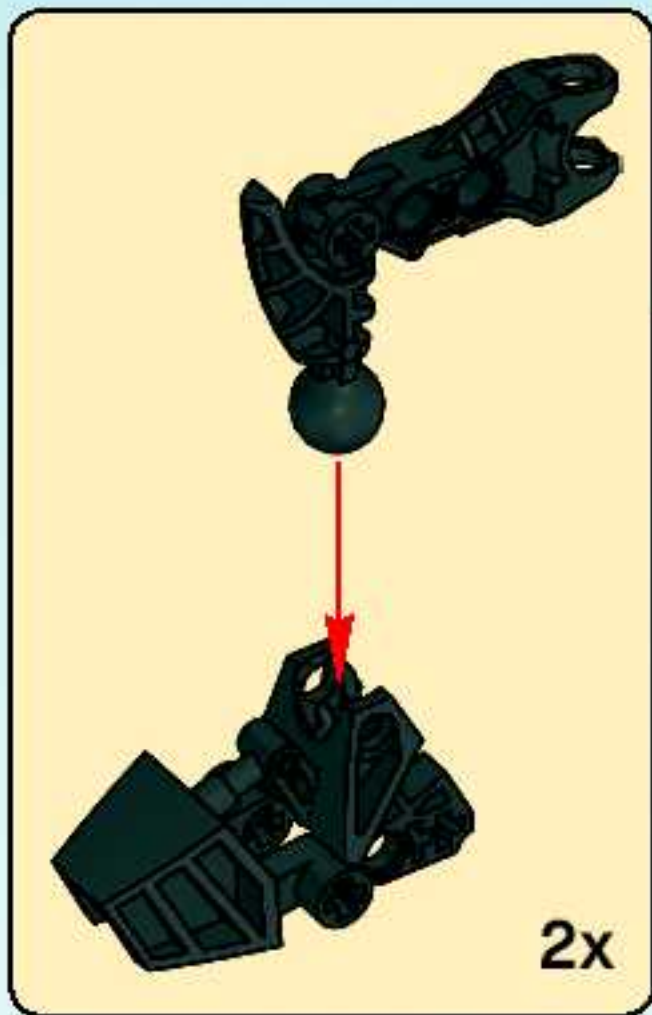

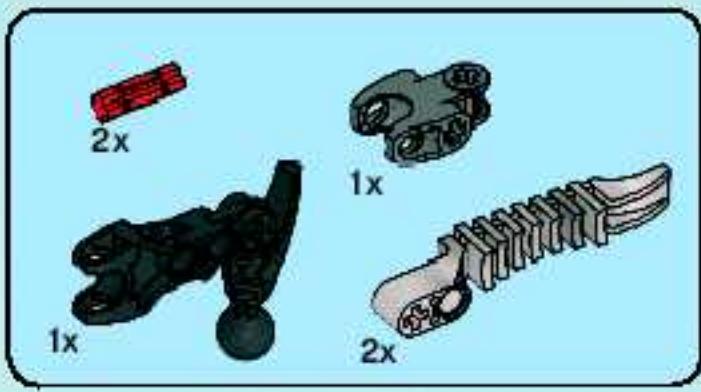

**3**

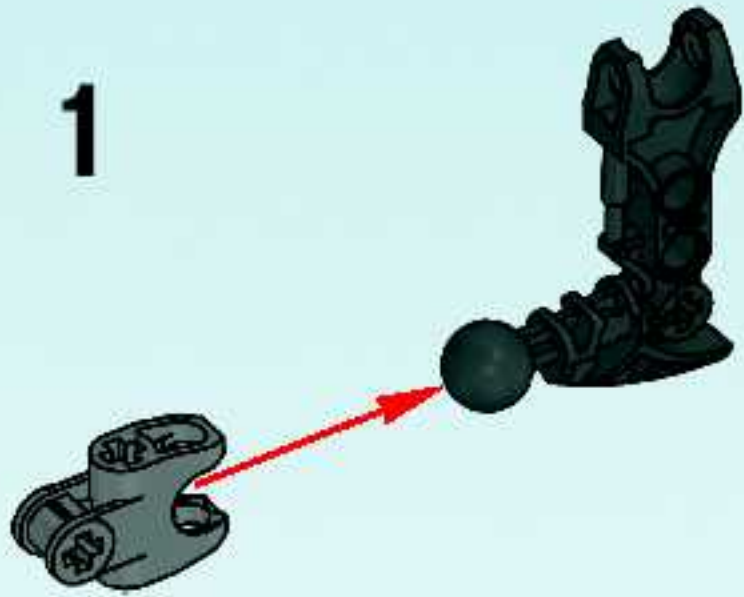

**2**



**3**

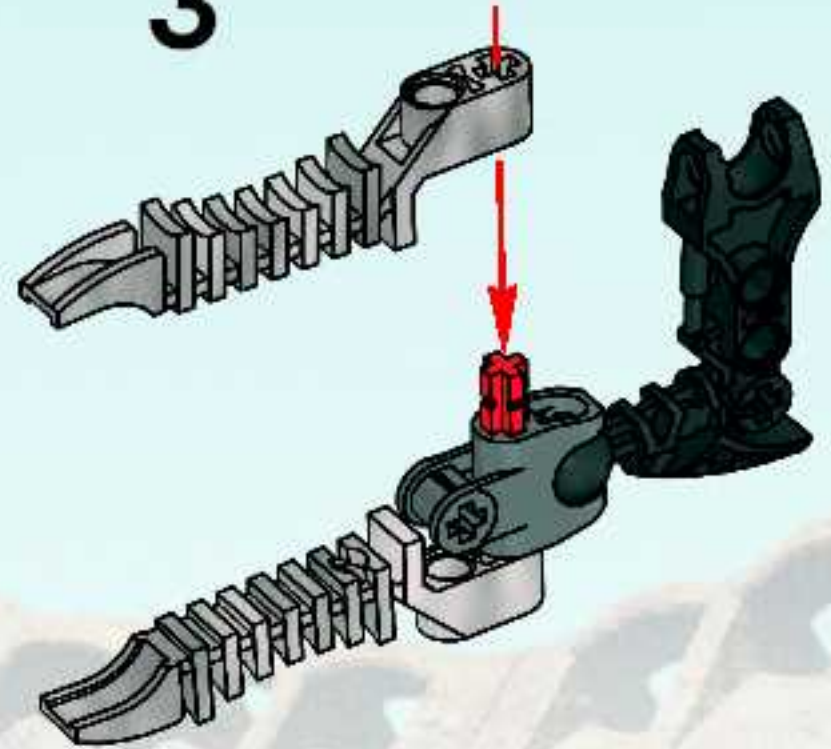





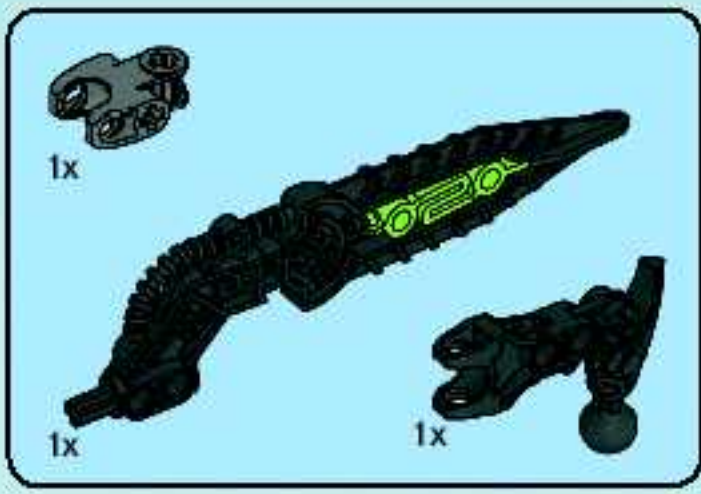

4

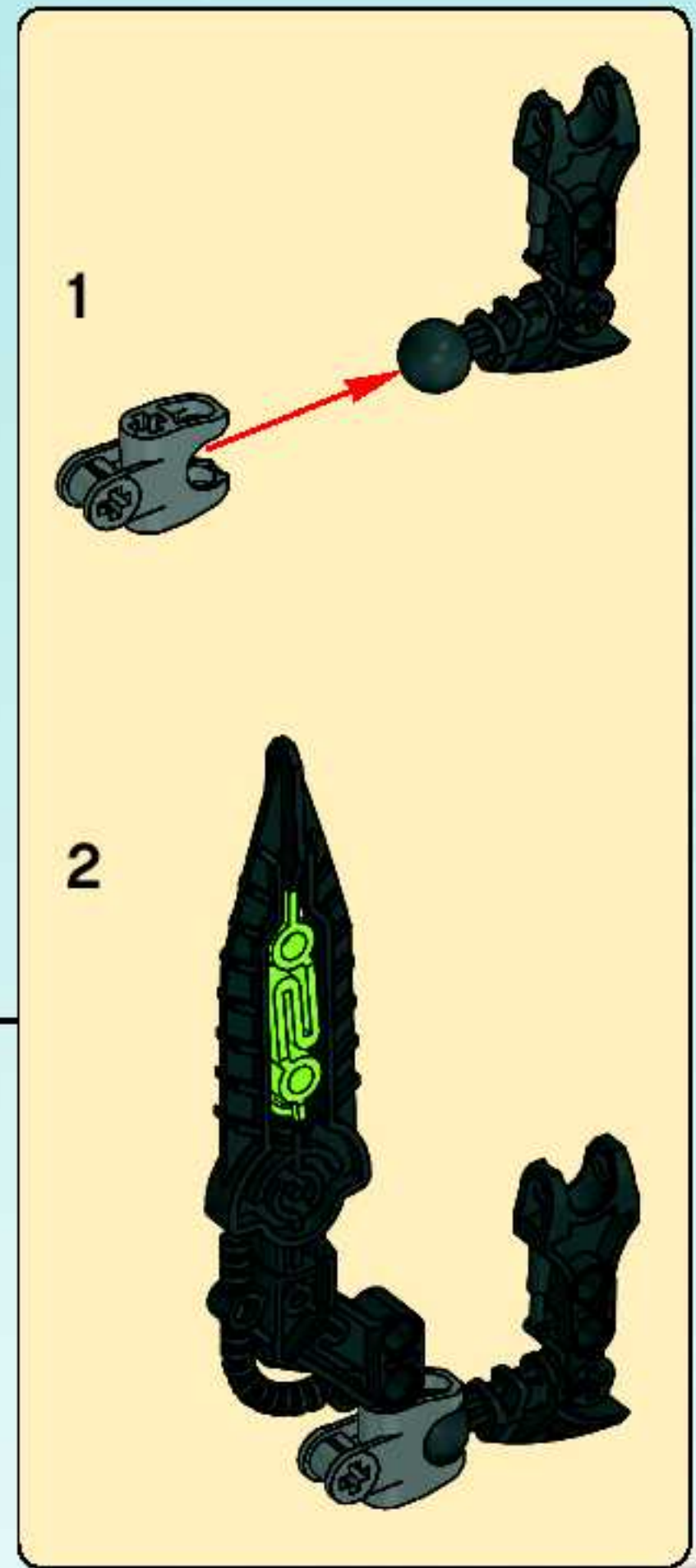



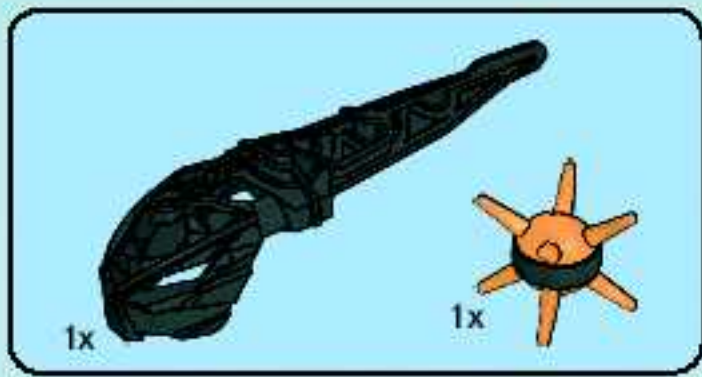

5

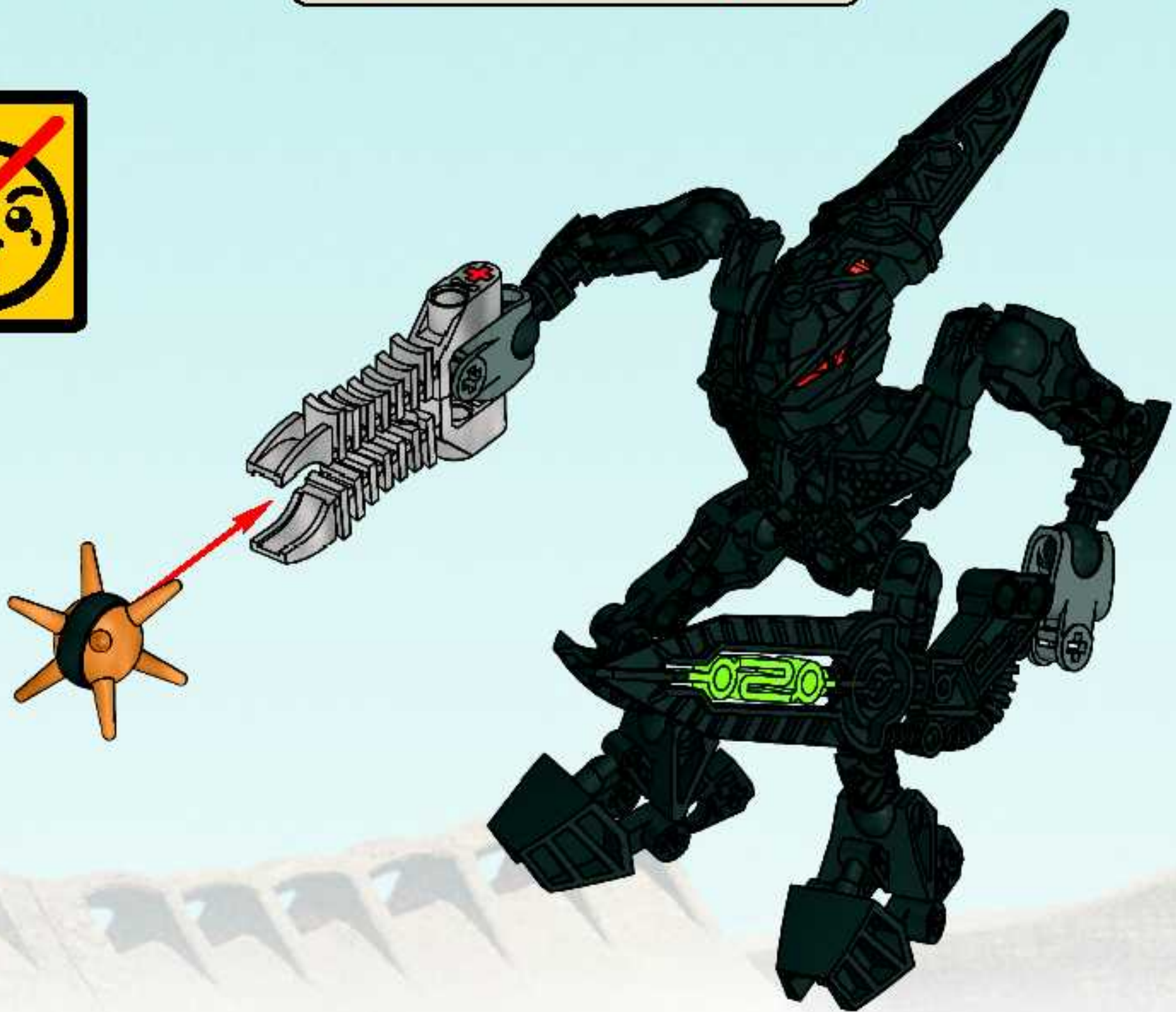
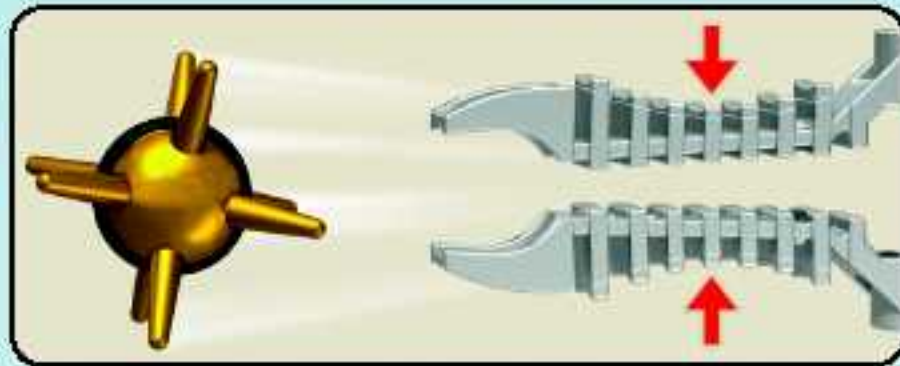
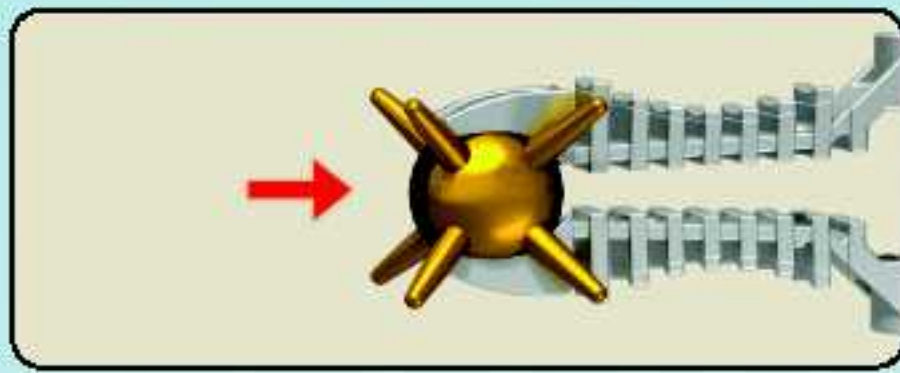





6





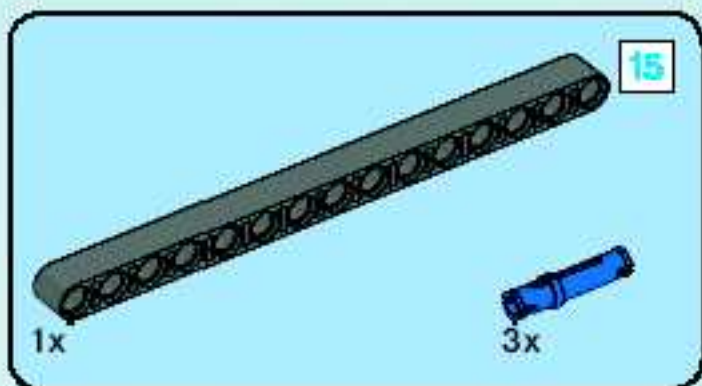
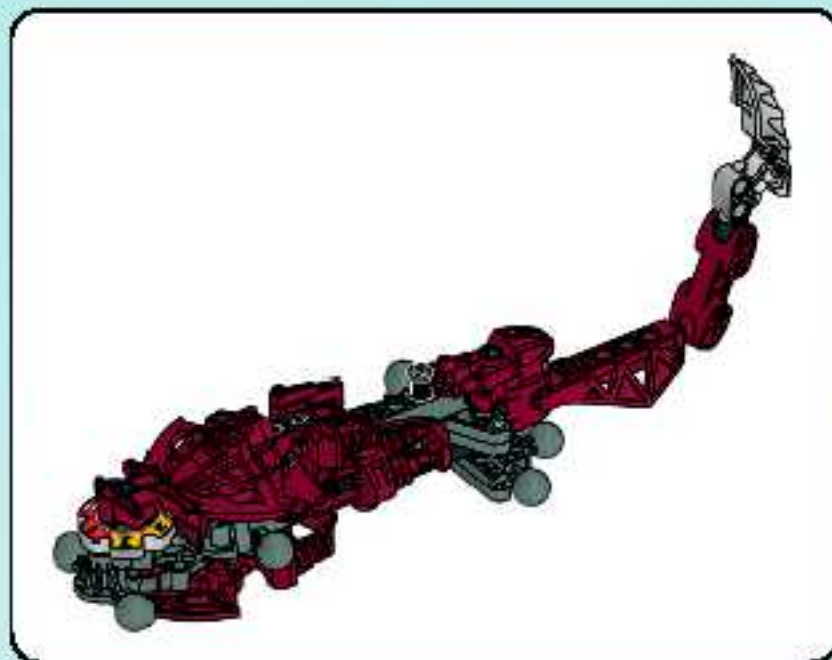
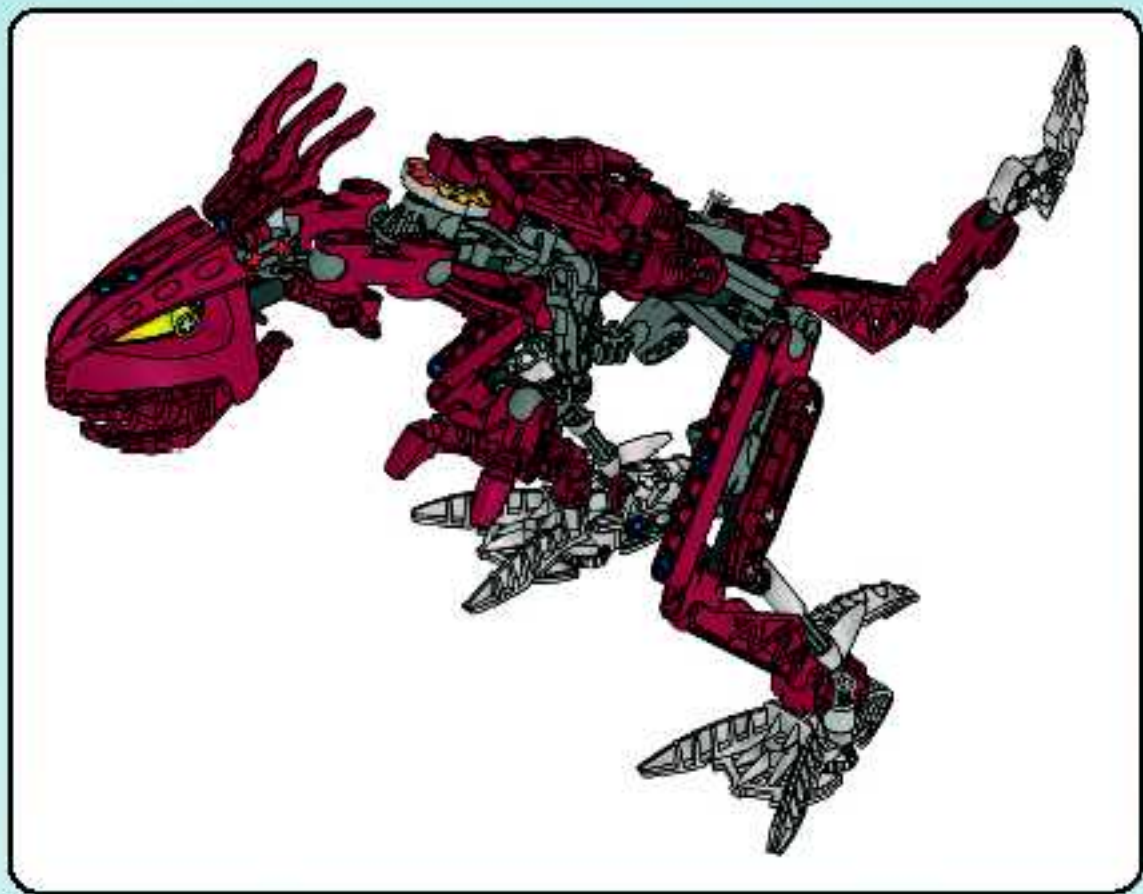

1

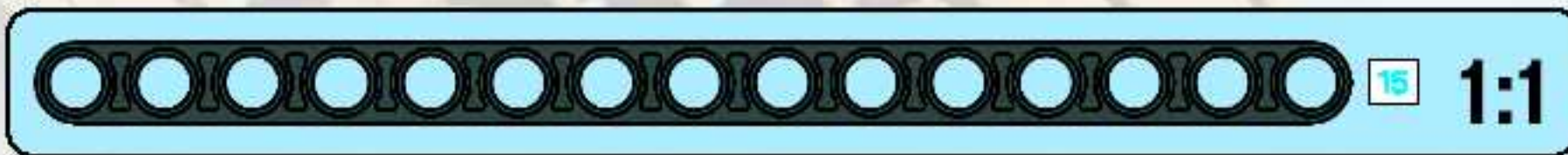
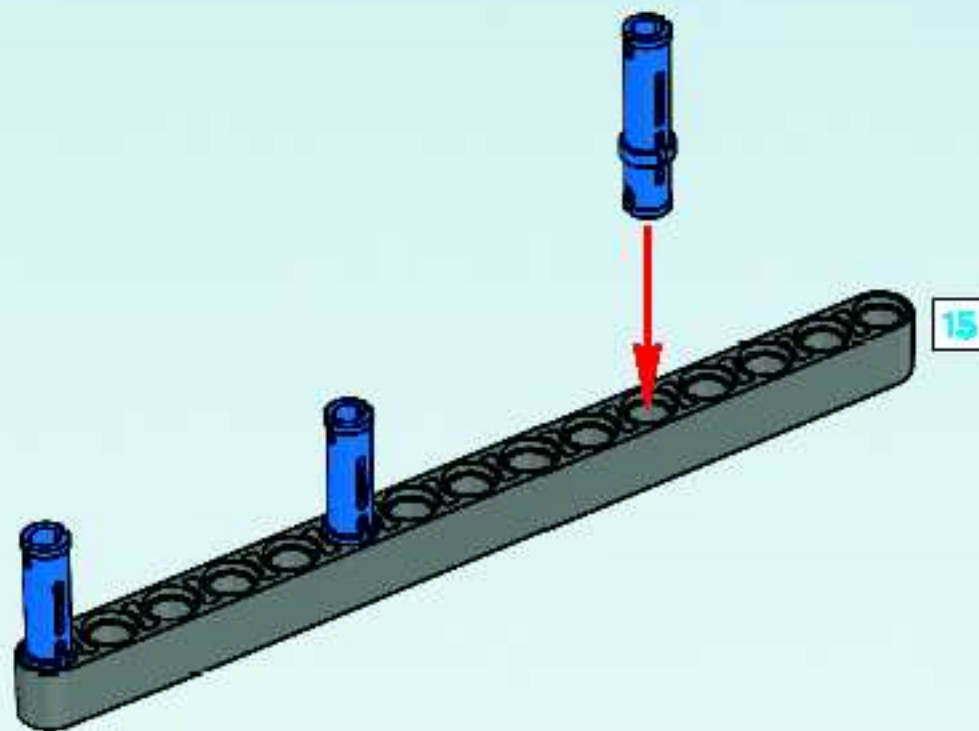





2

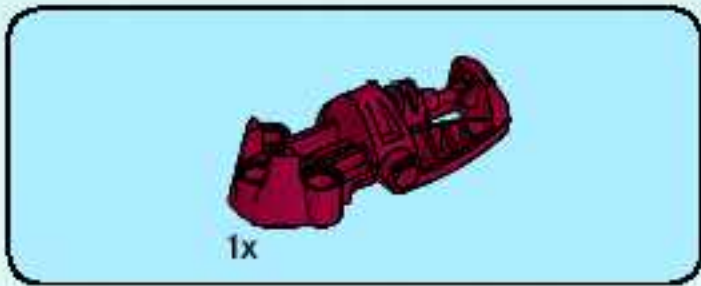
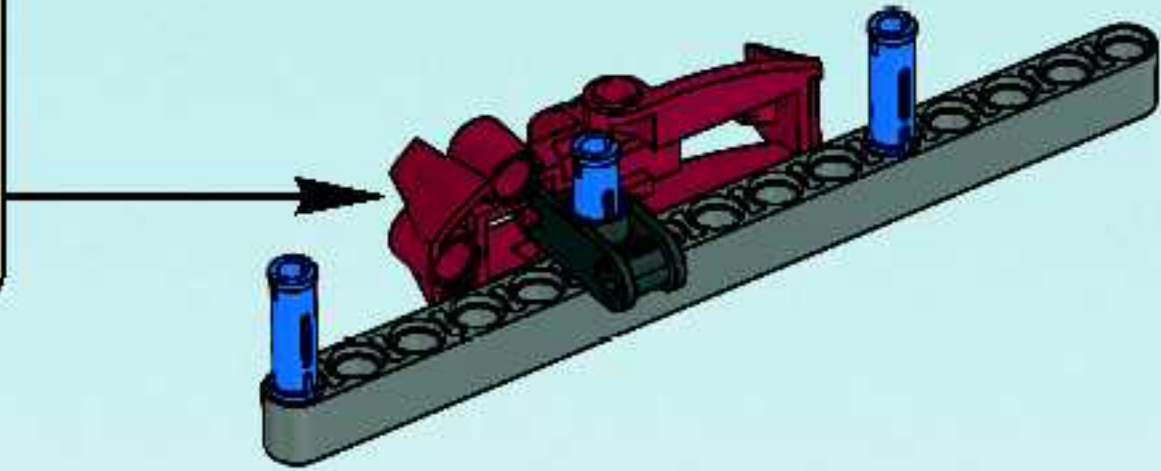
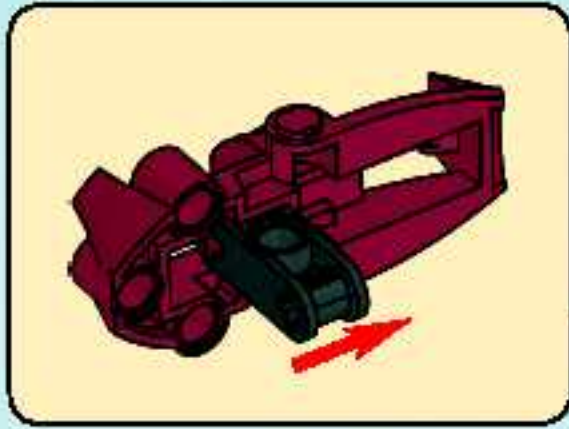

3

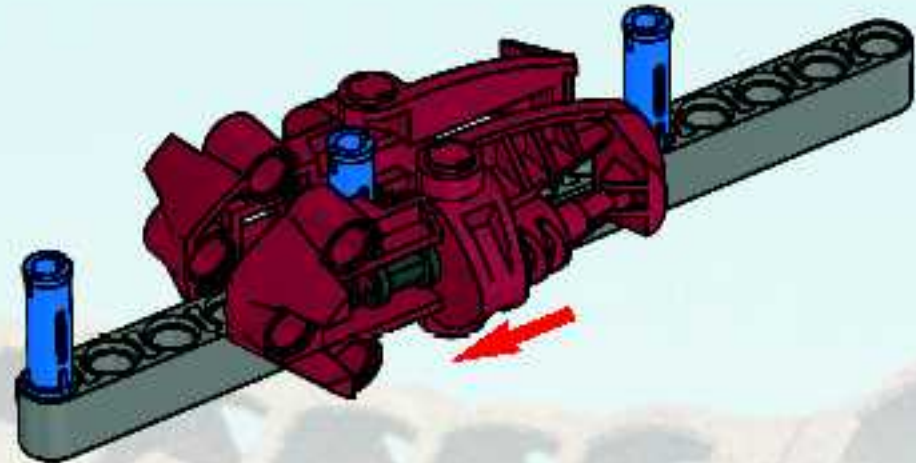



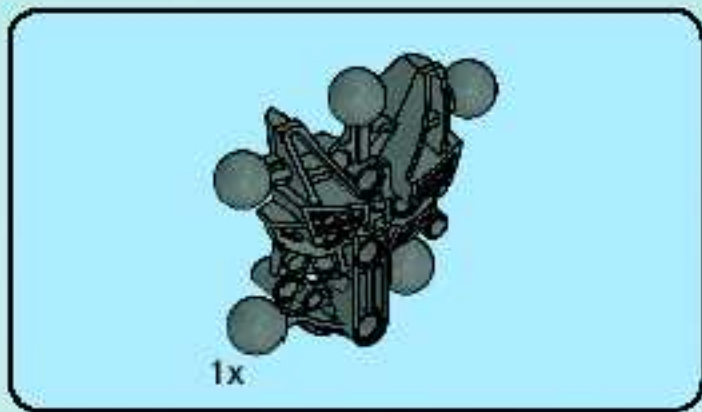

4

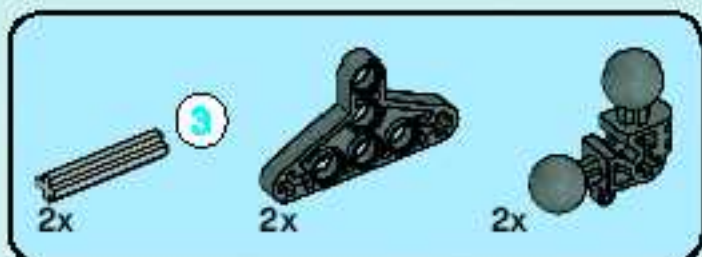
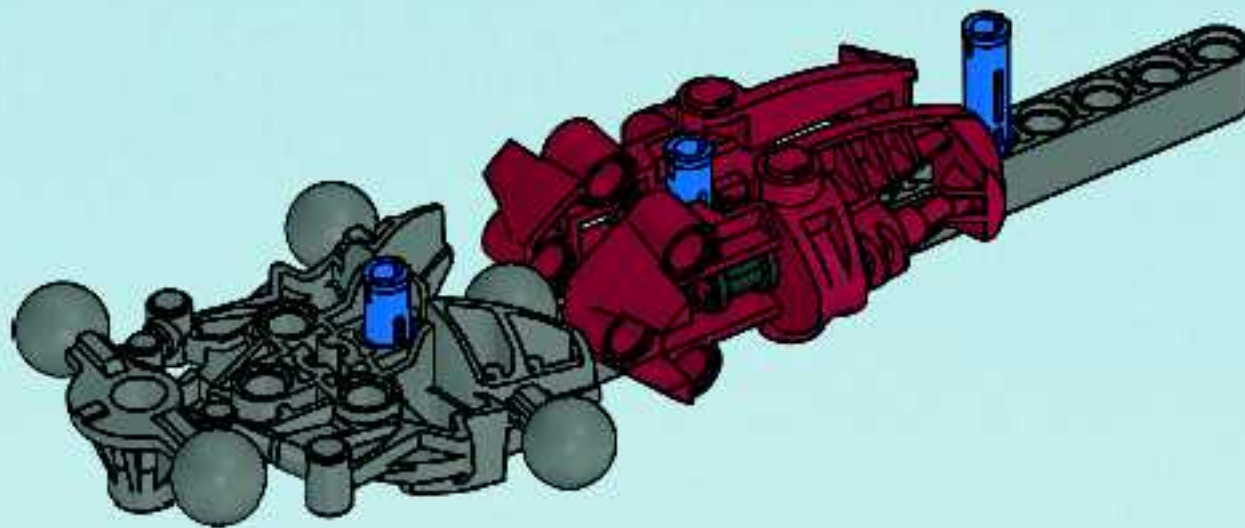

5

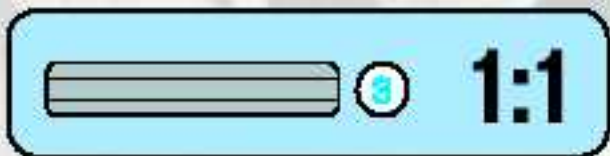
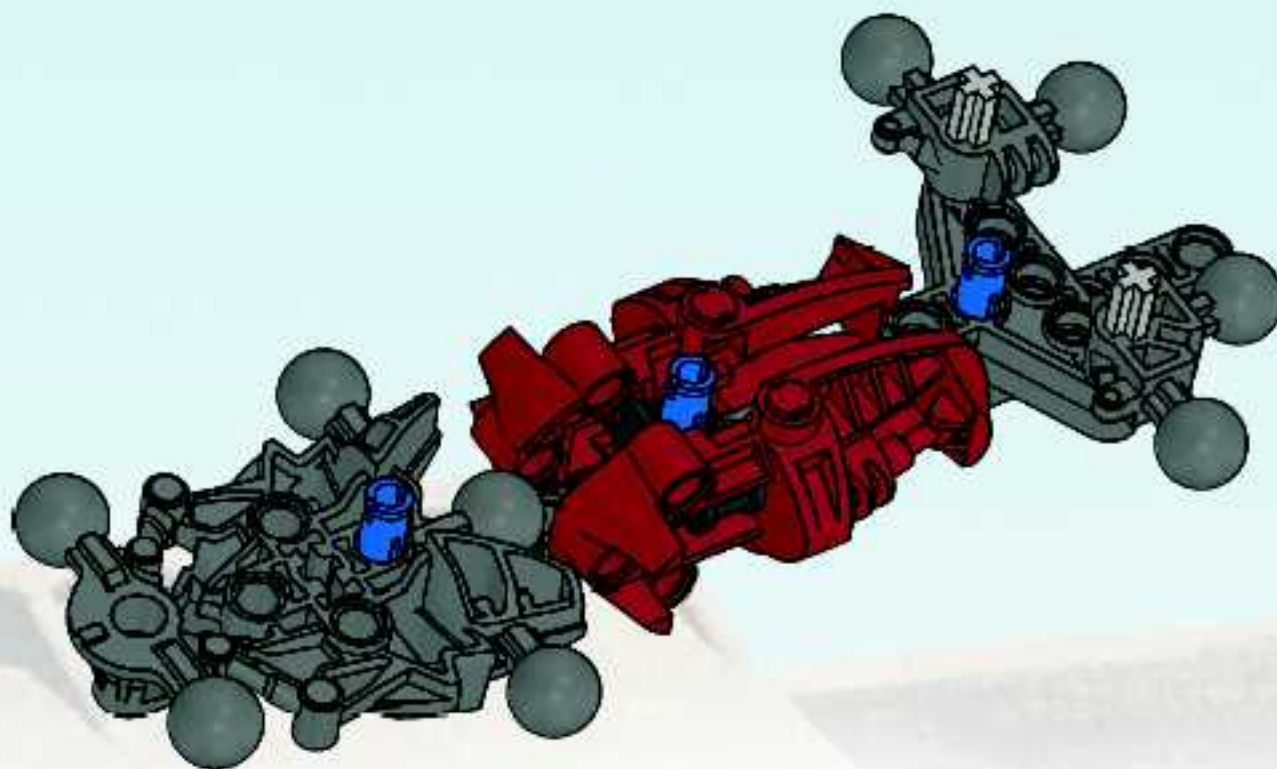
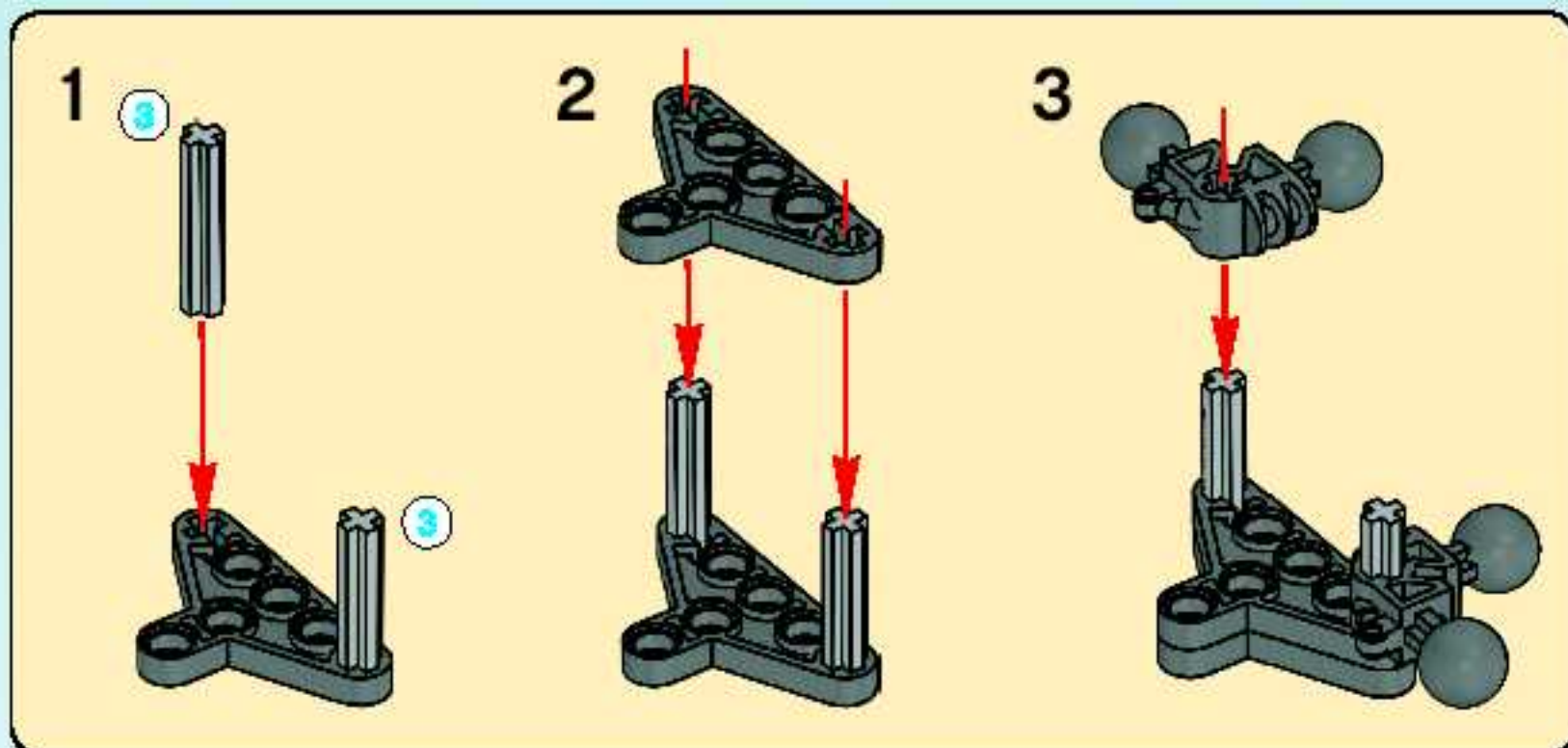





6

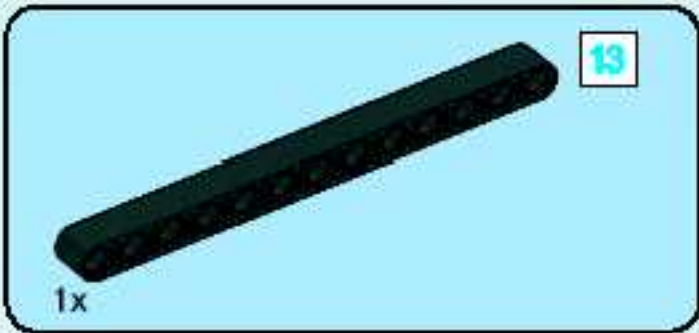
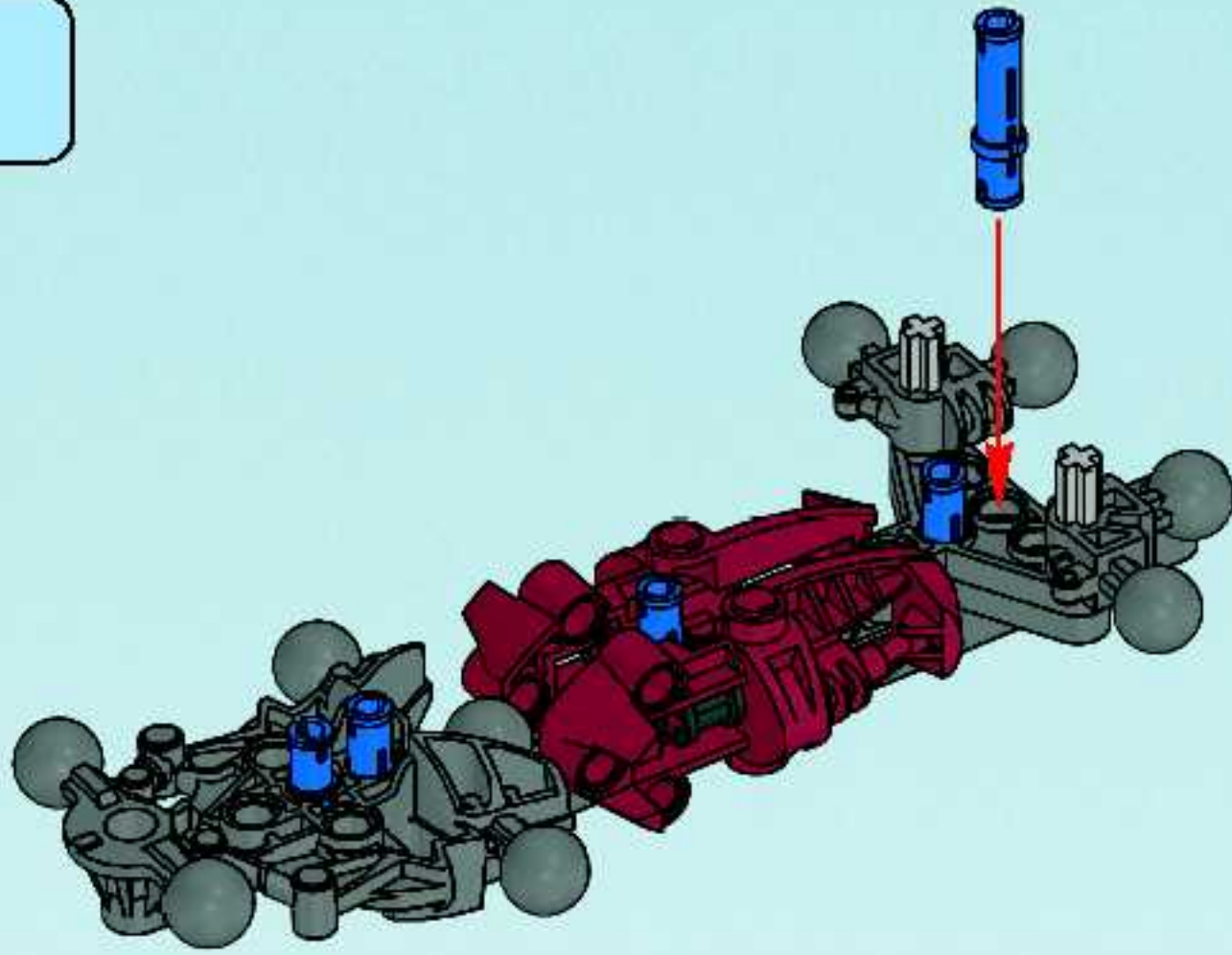

7

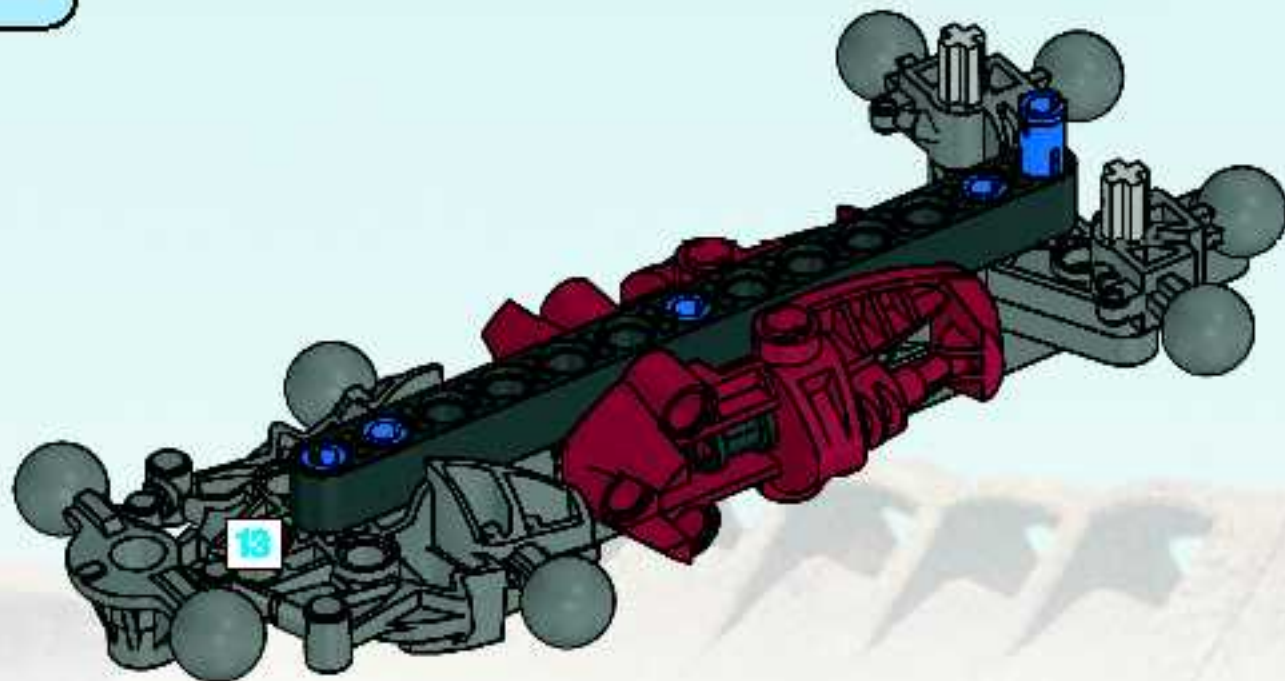
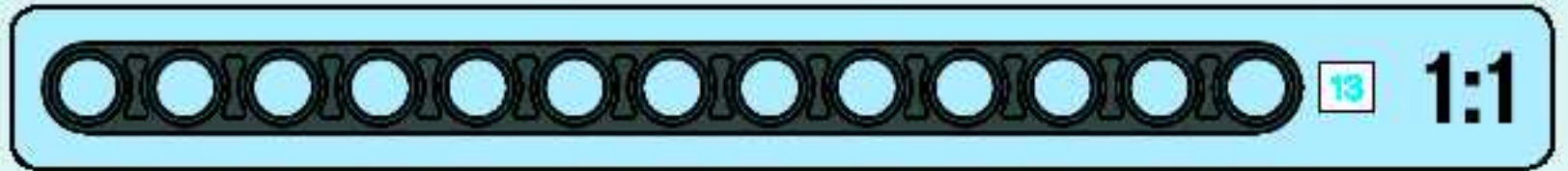

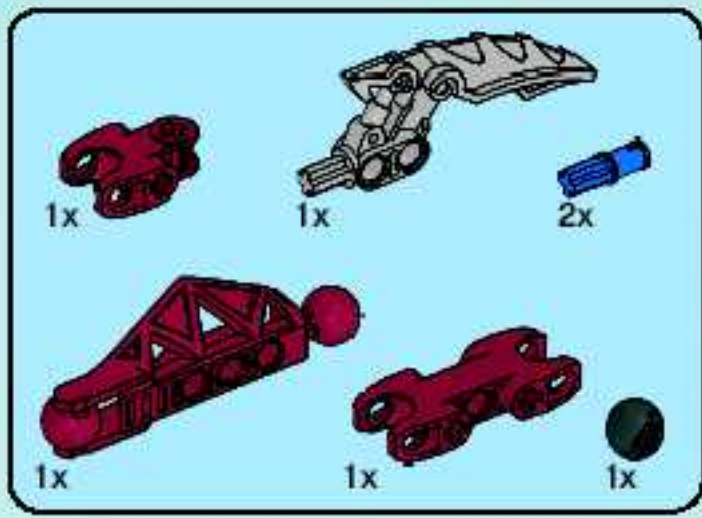

8

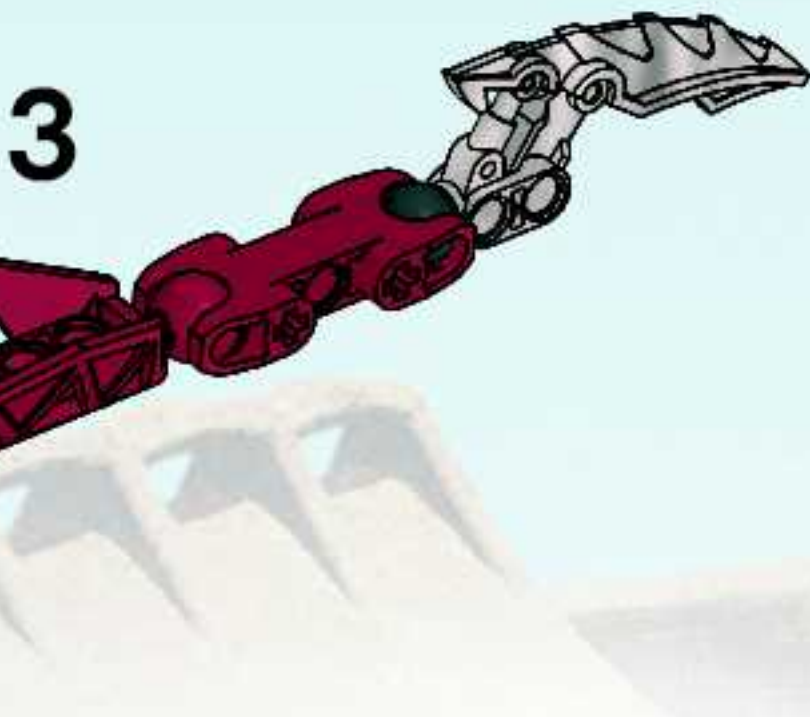
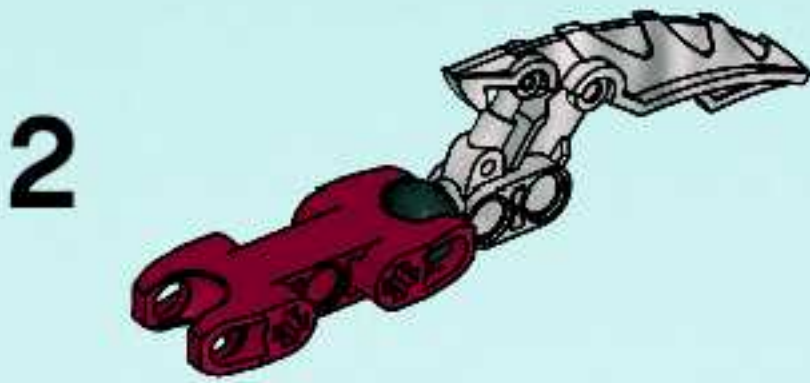
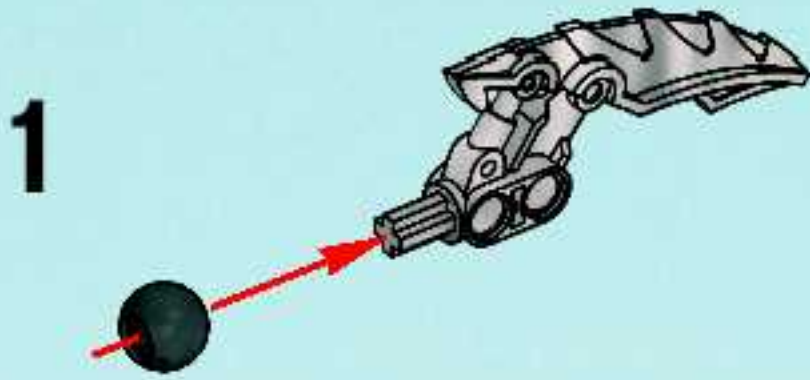



4

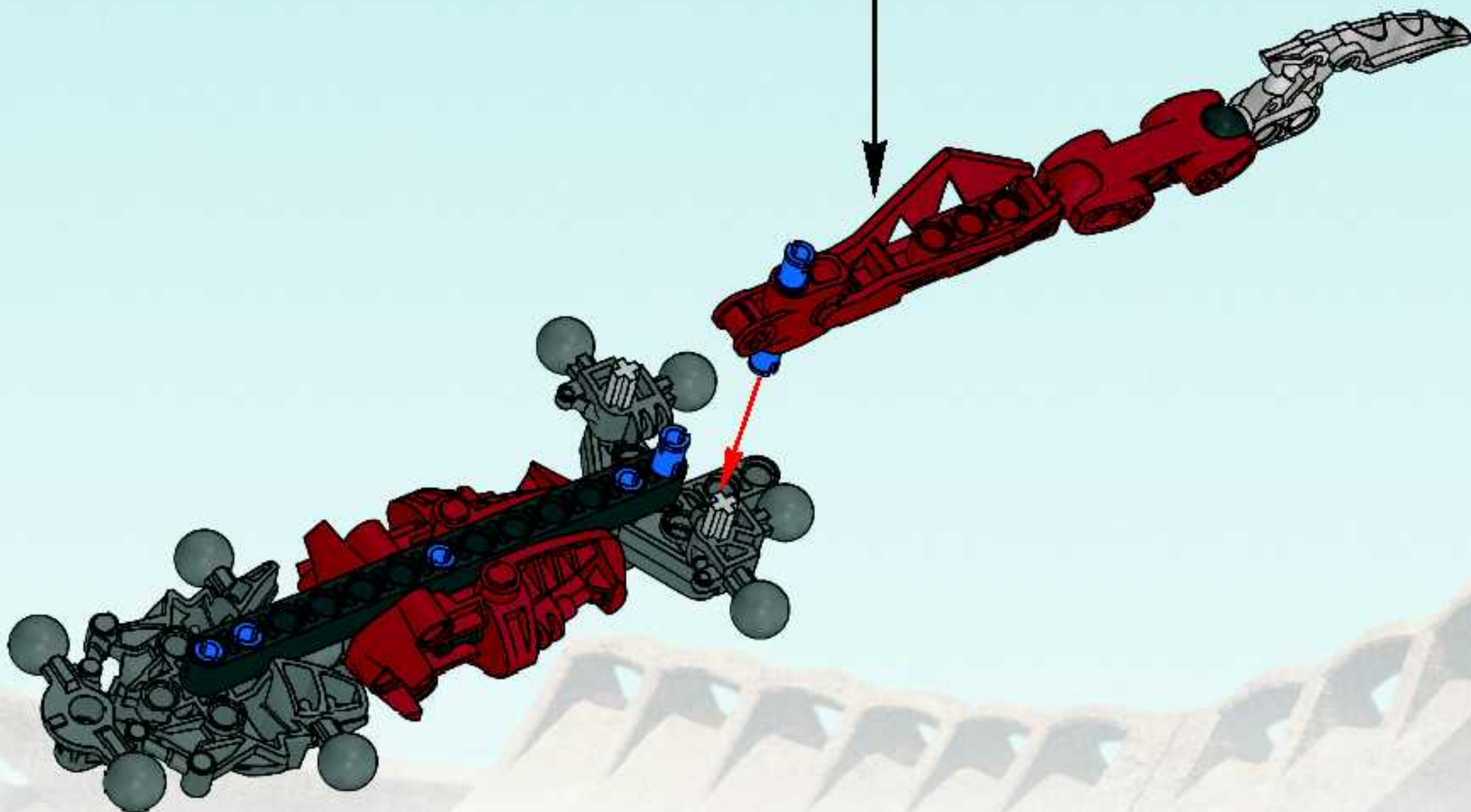
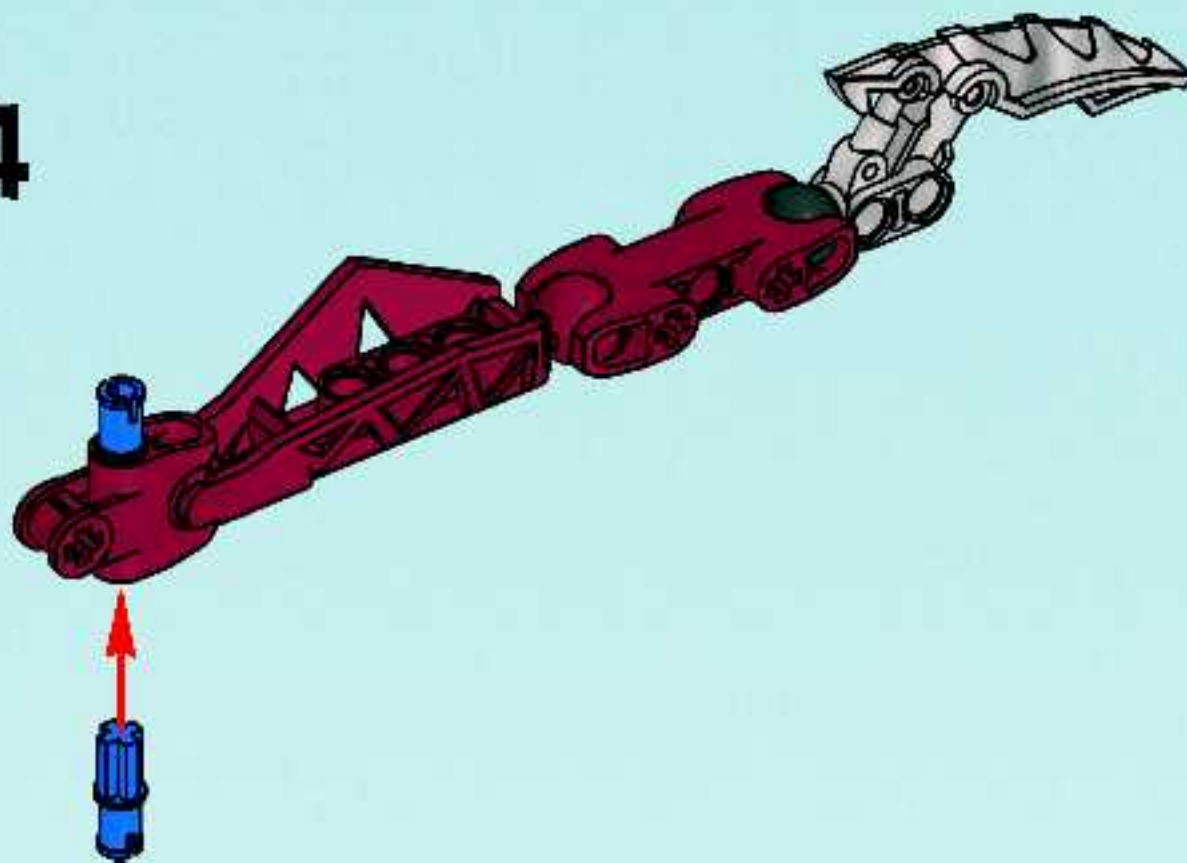

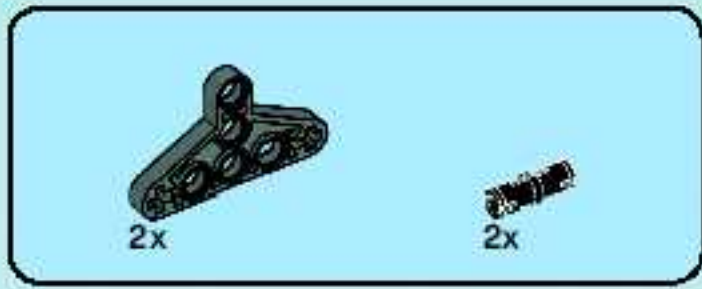

9

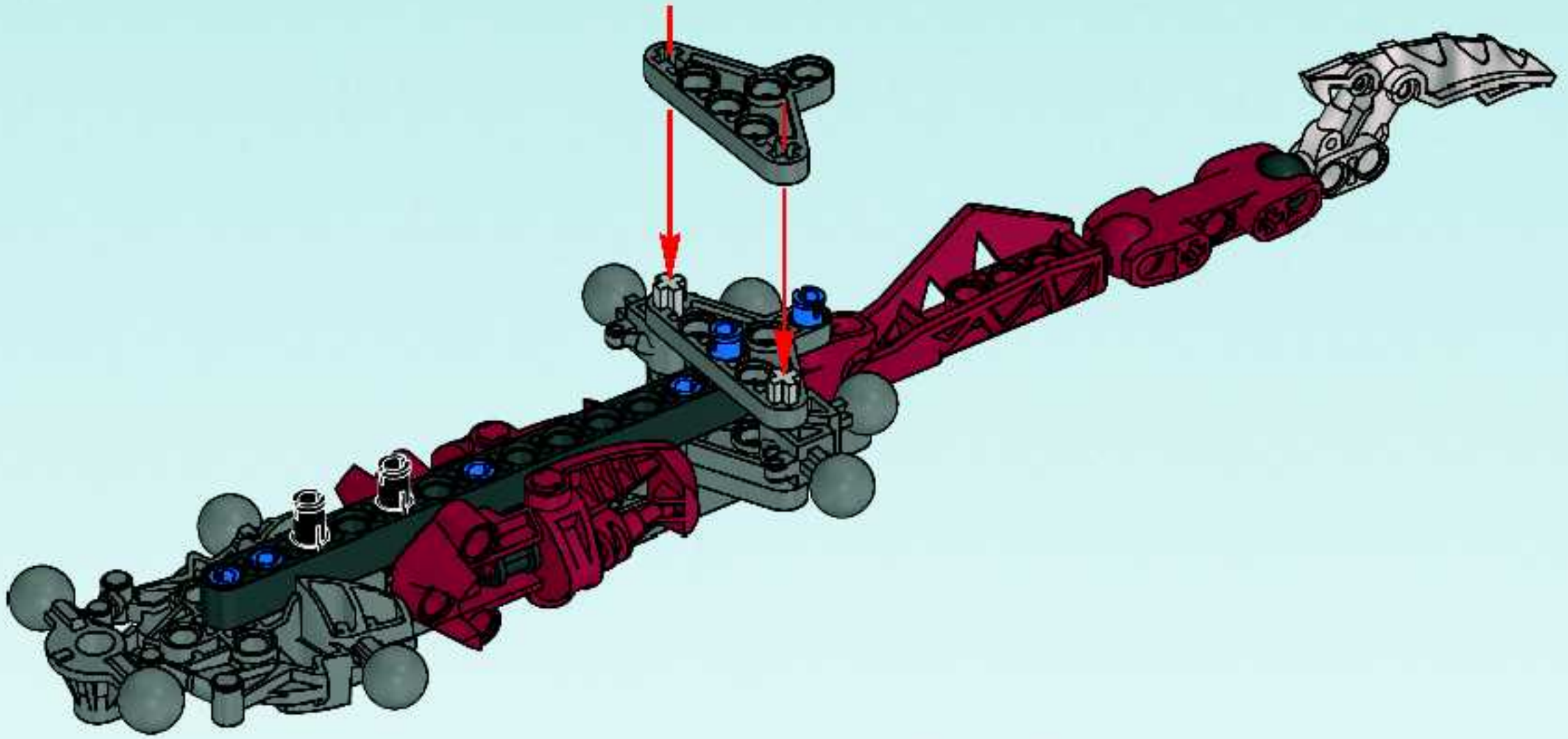



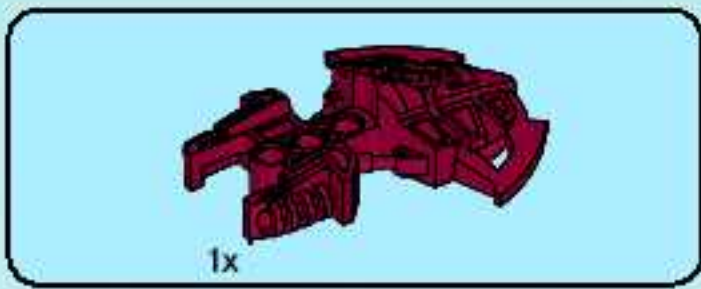

10

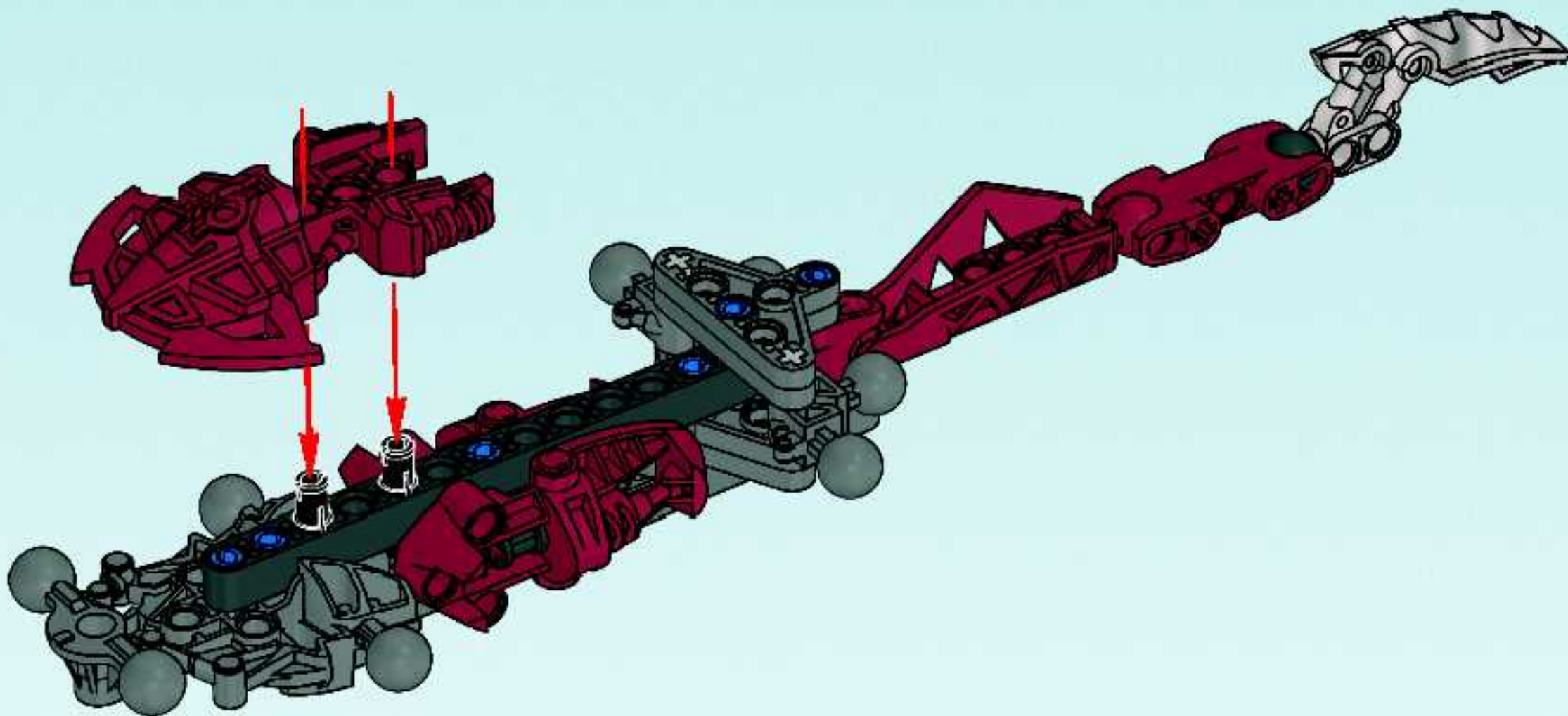



11

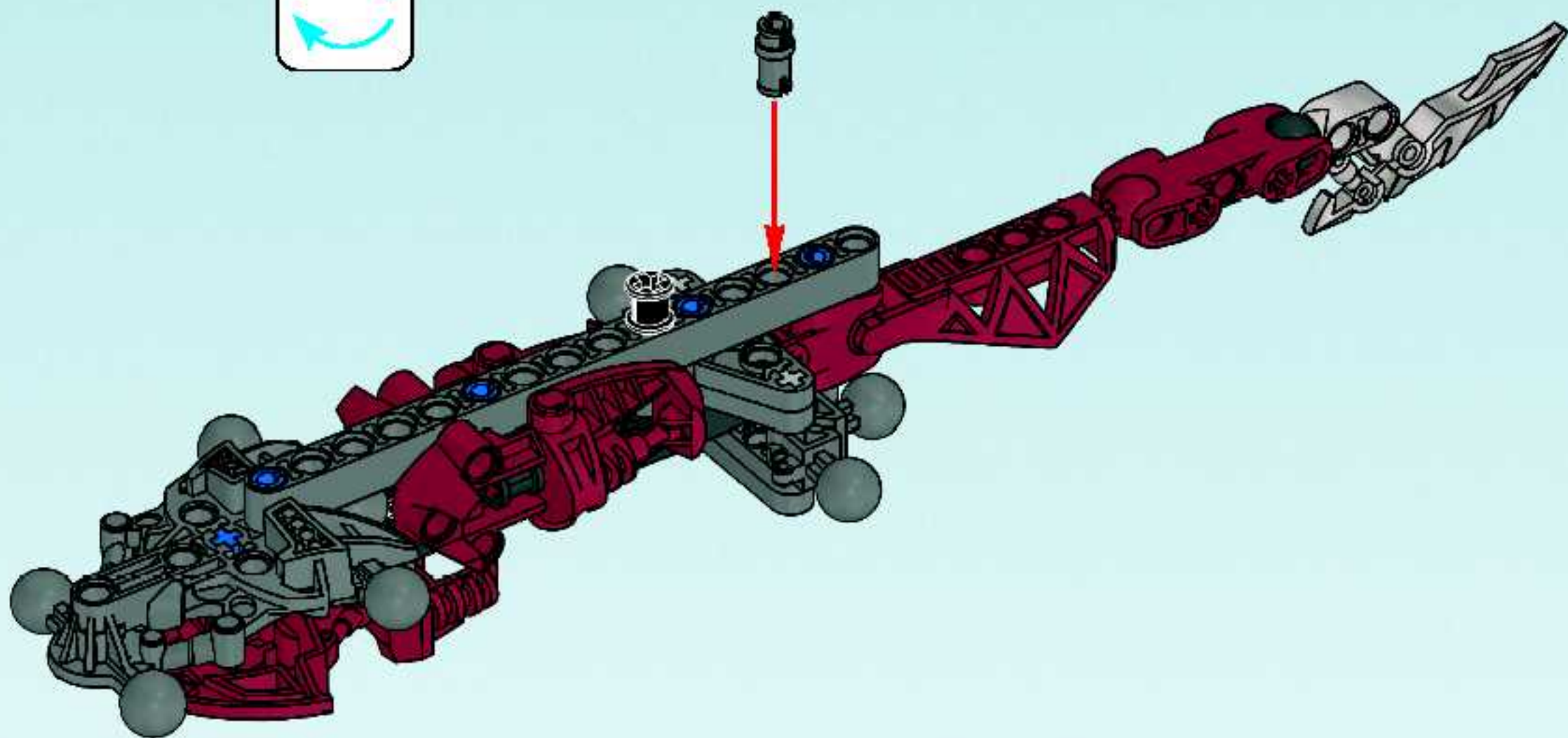





12

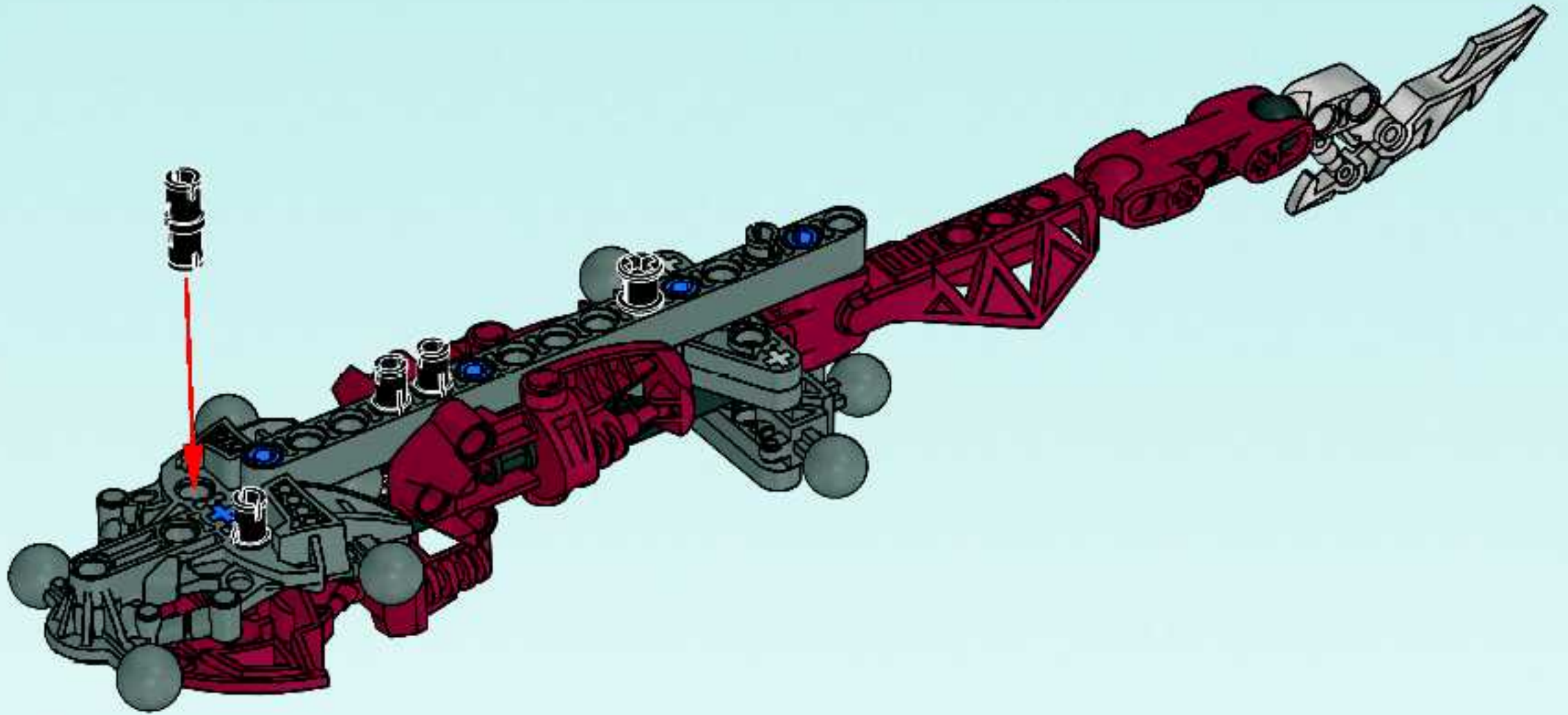

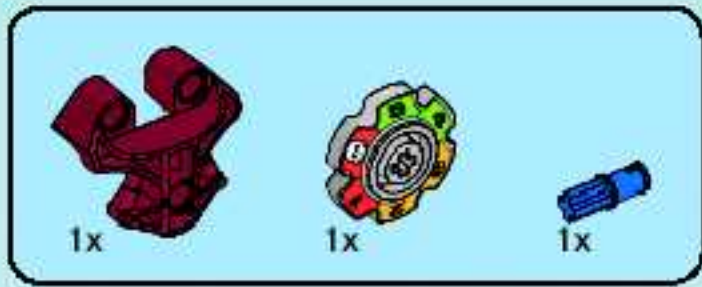

13

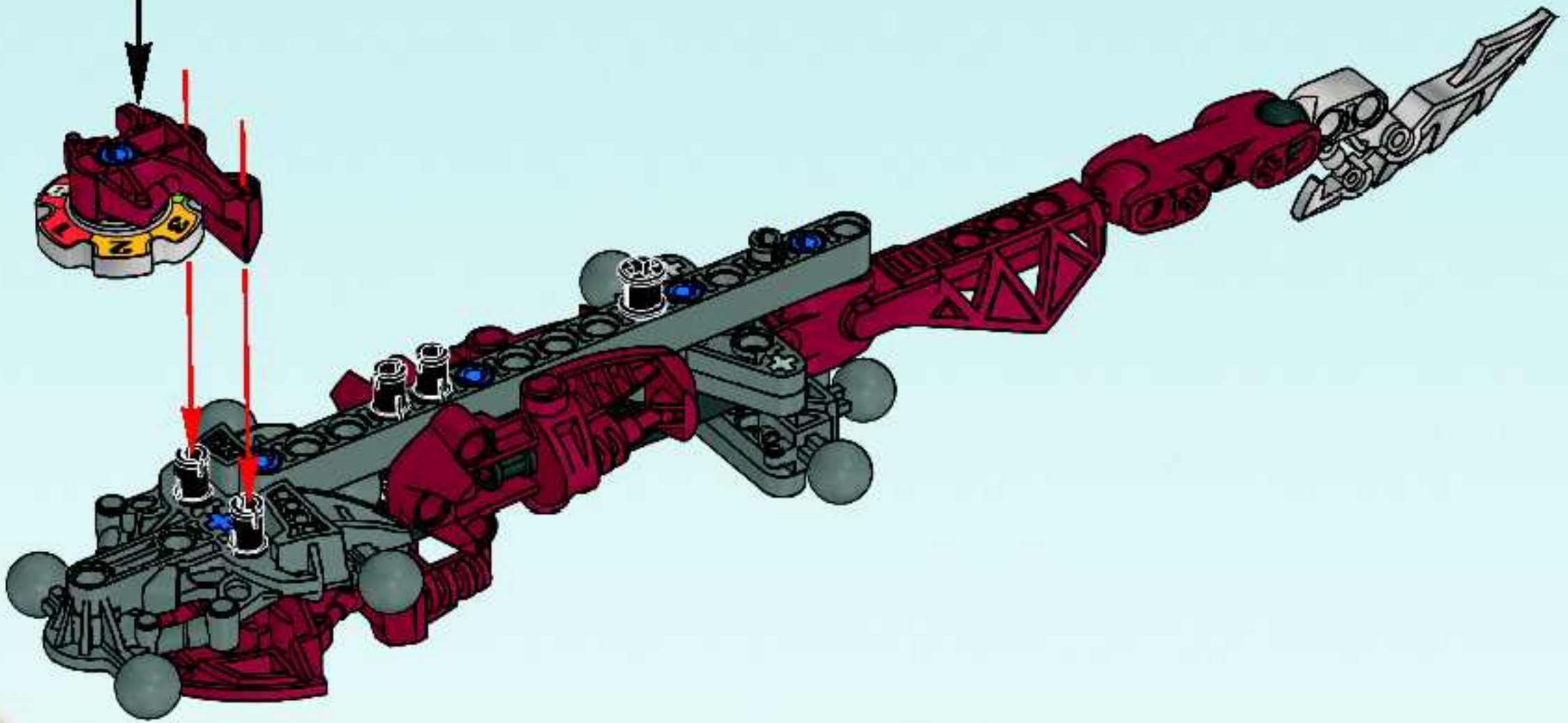
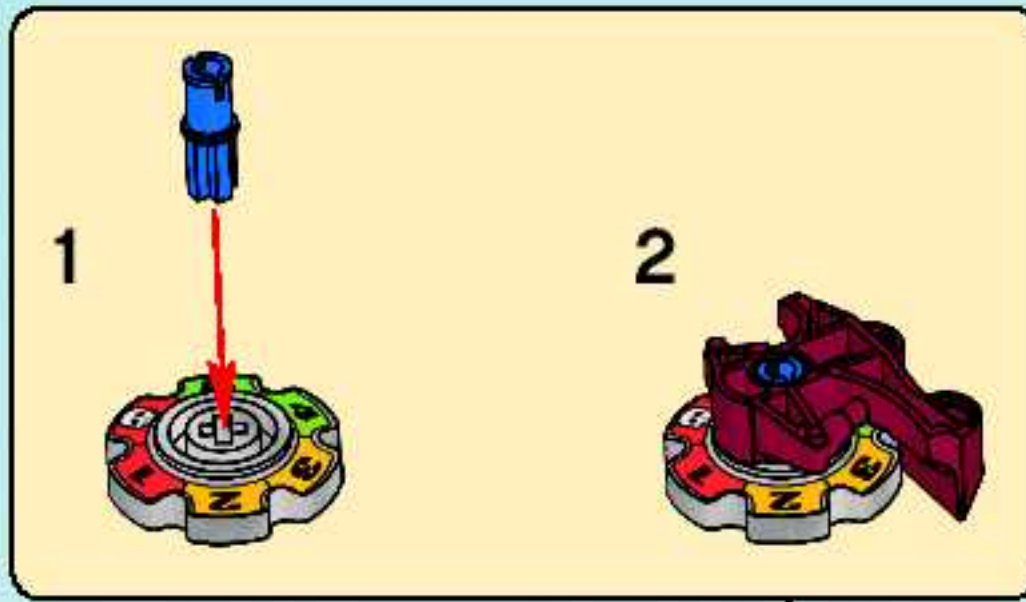



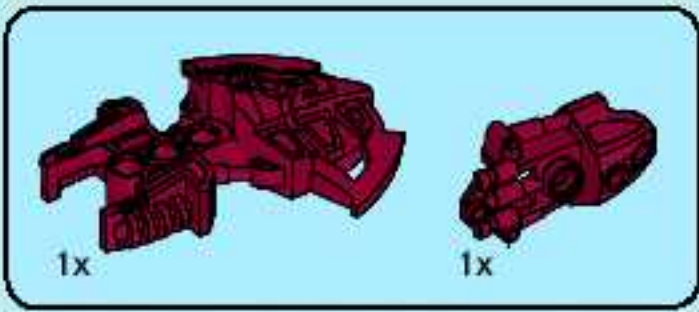

14

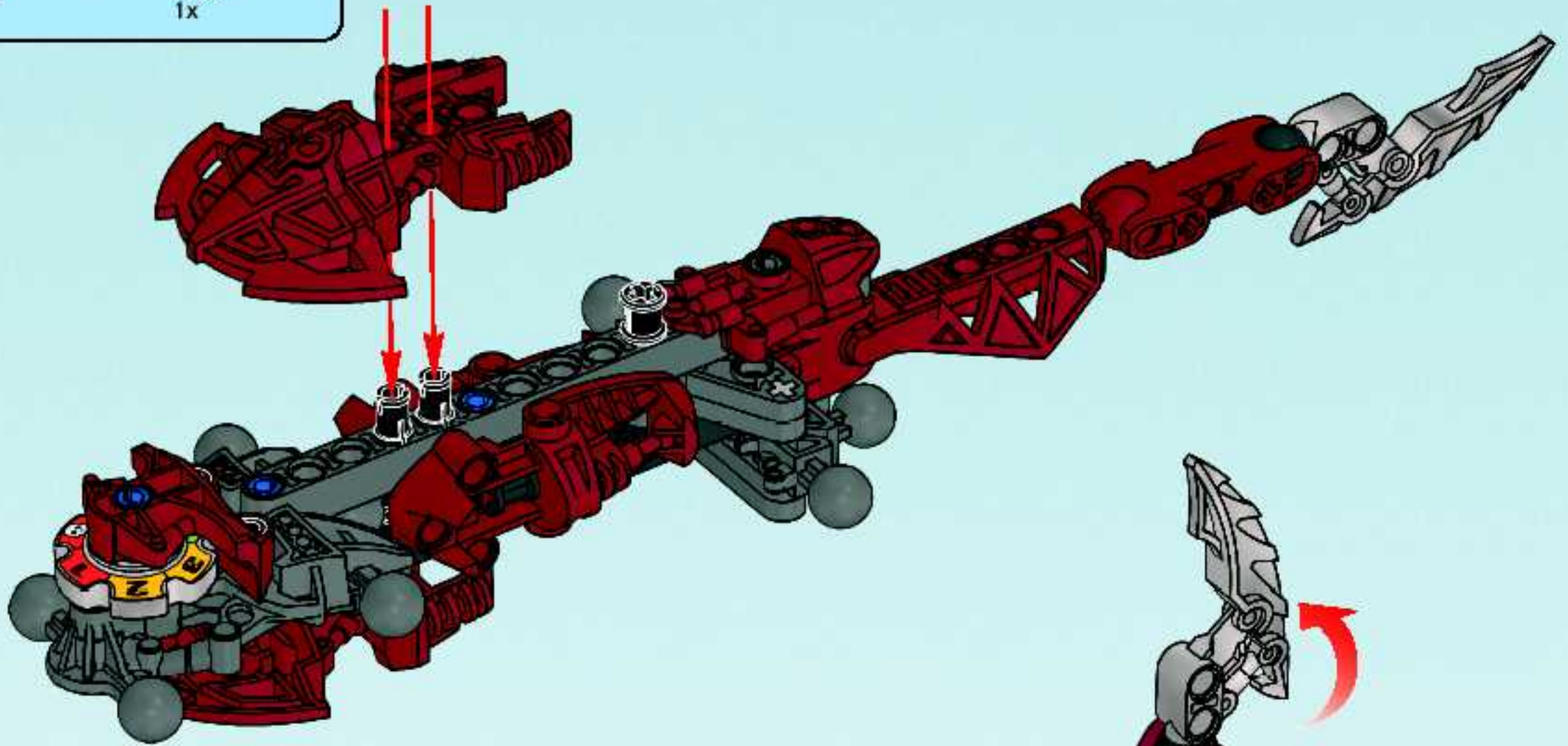

15

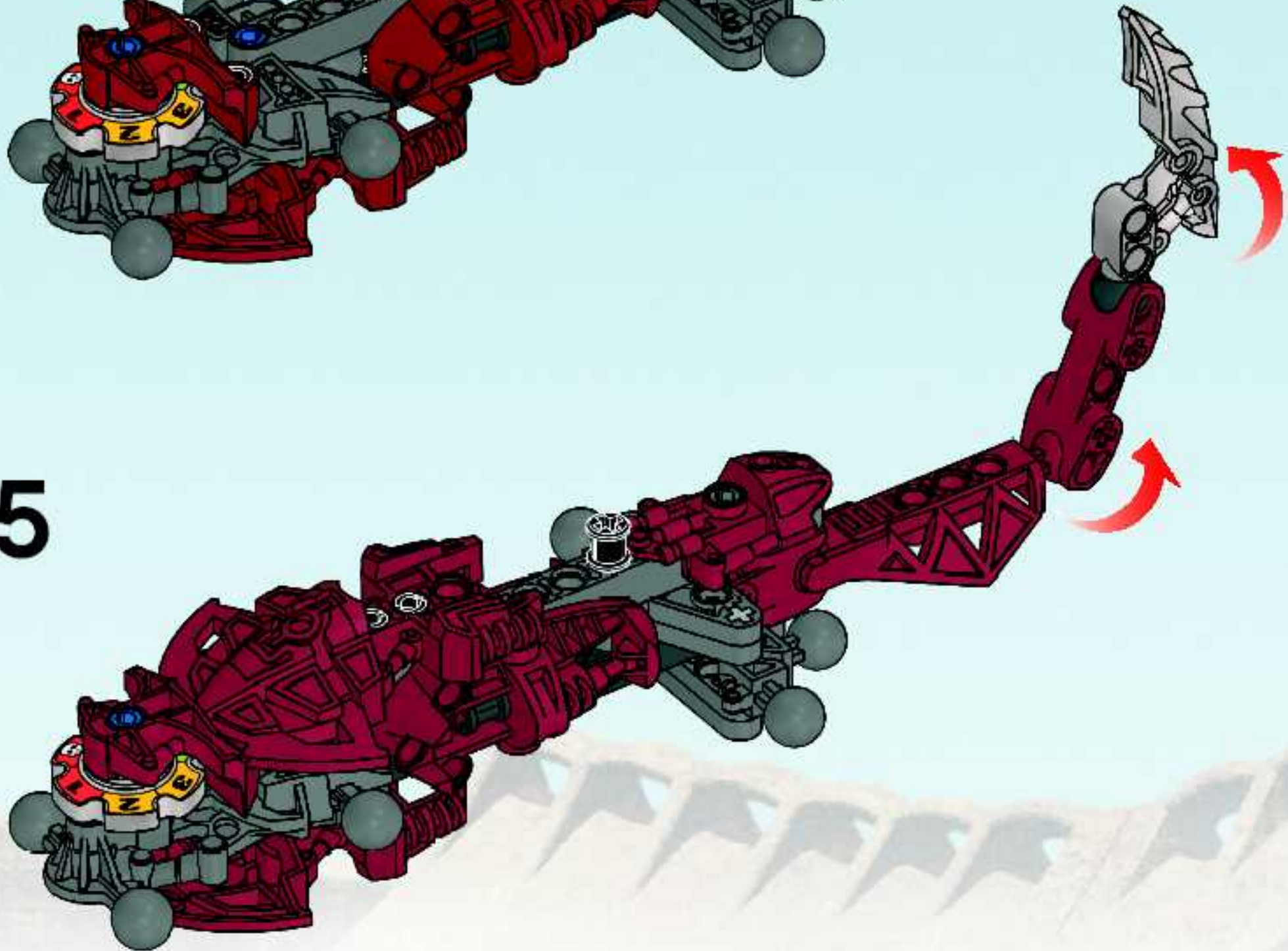

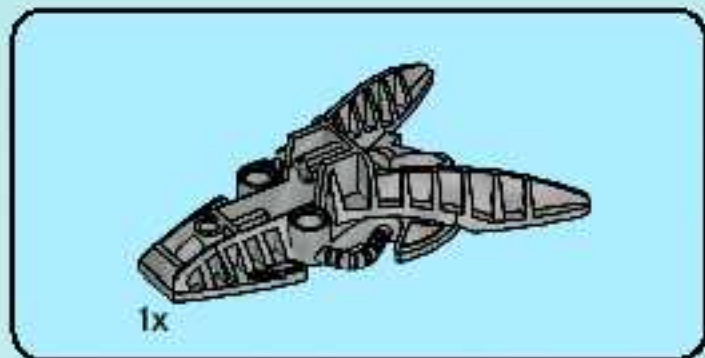
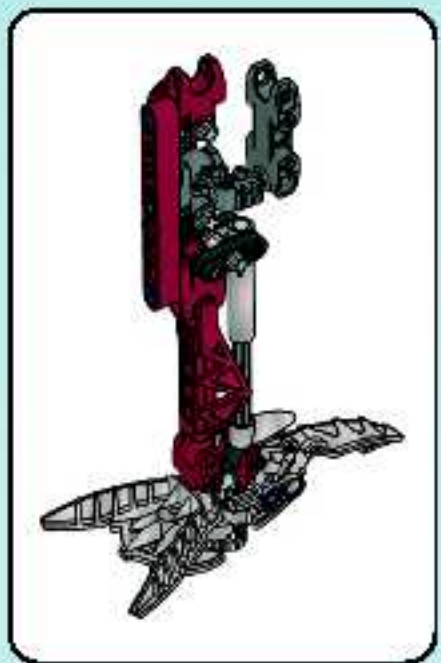

1

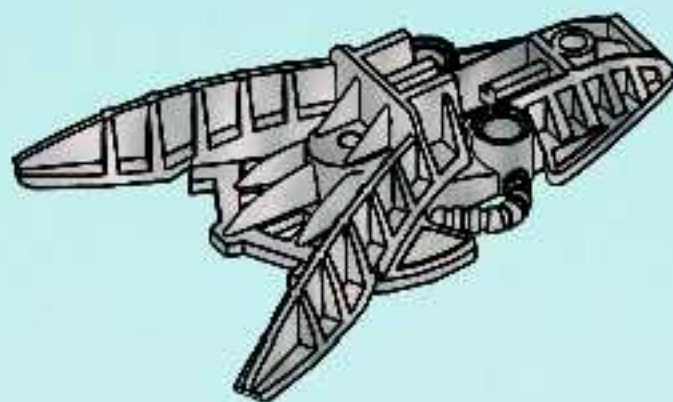

2

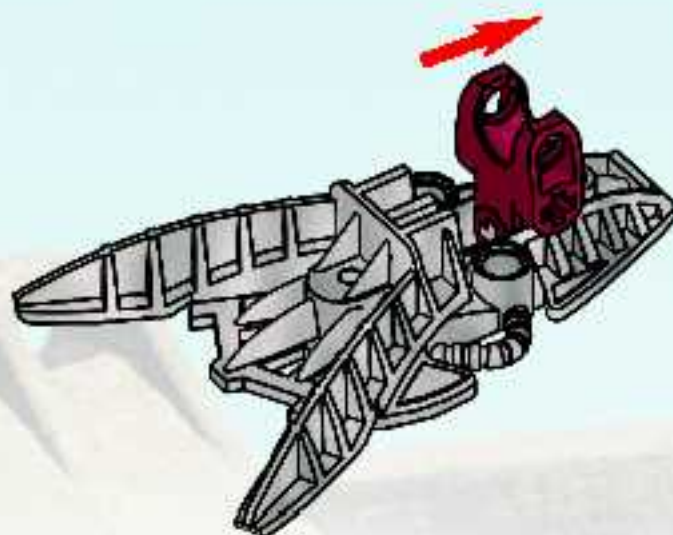





3

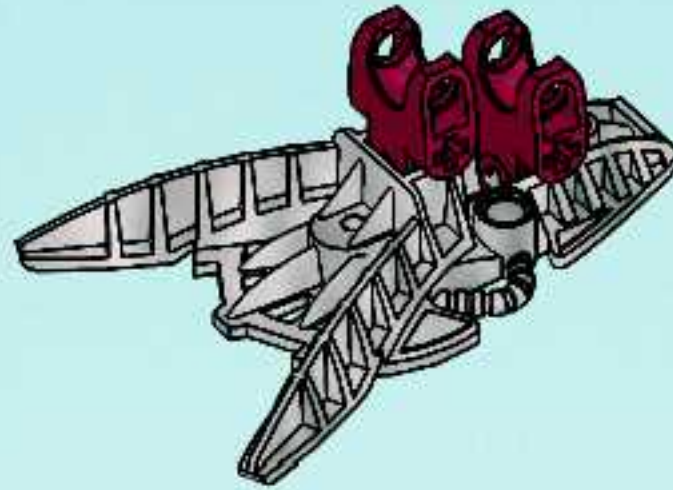

4

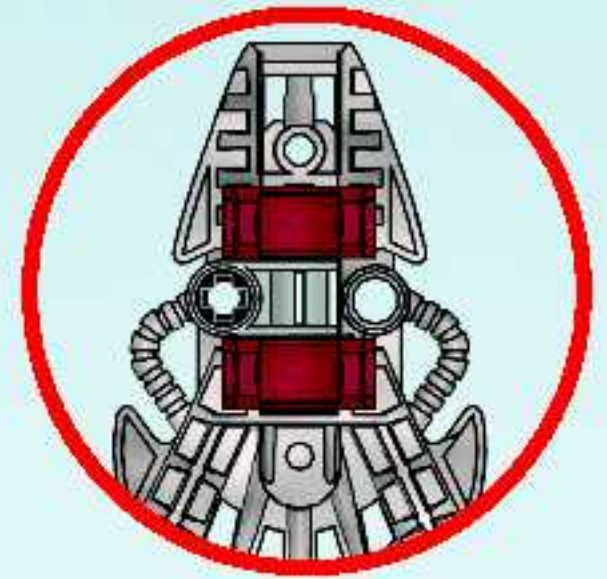
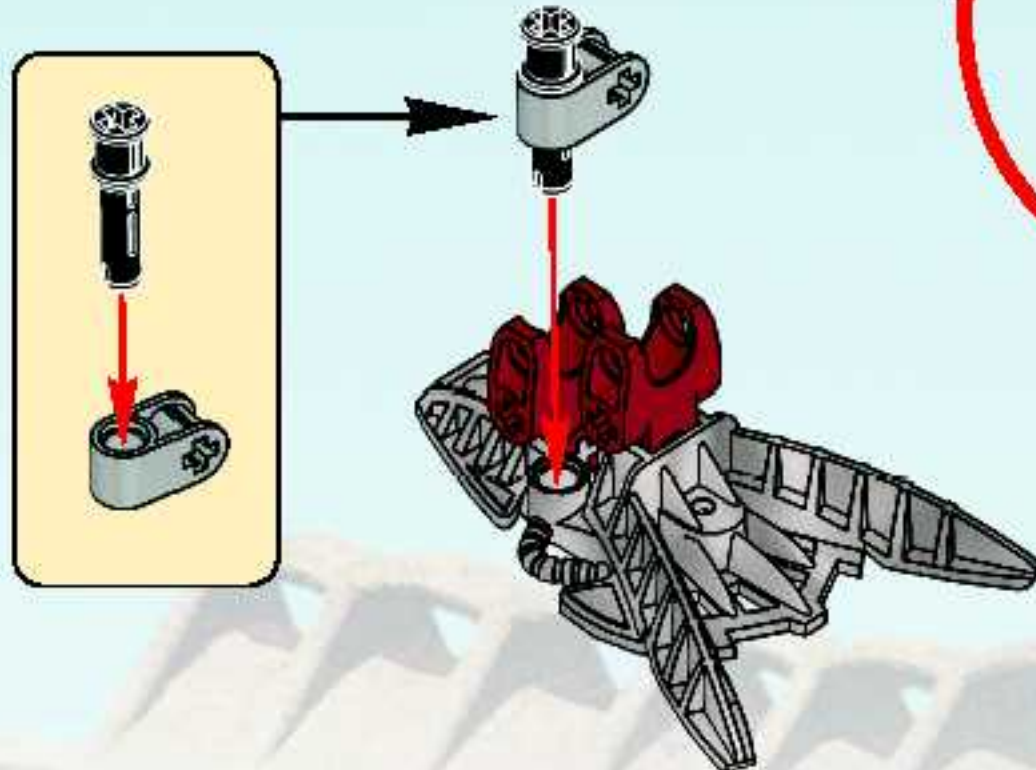

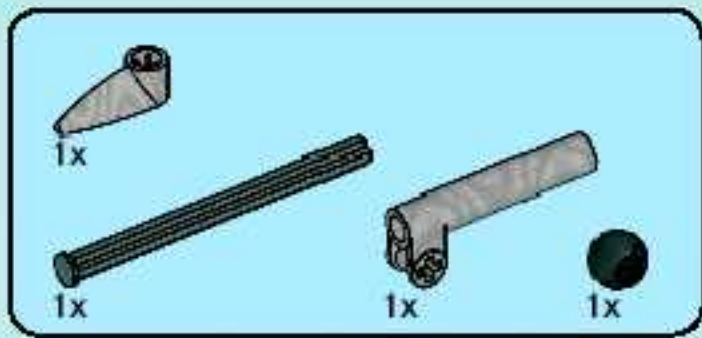

5

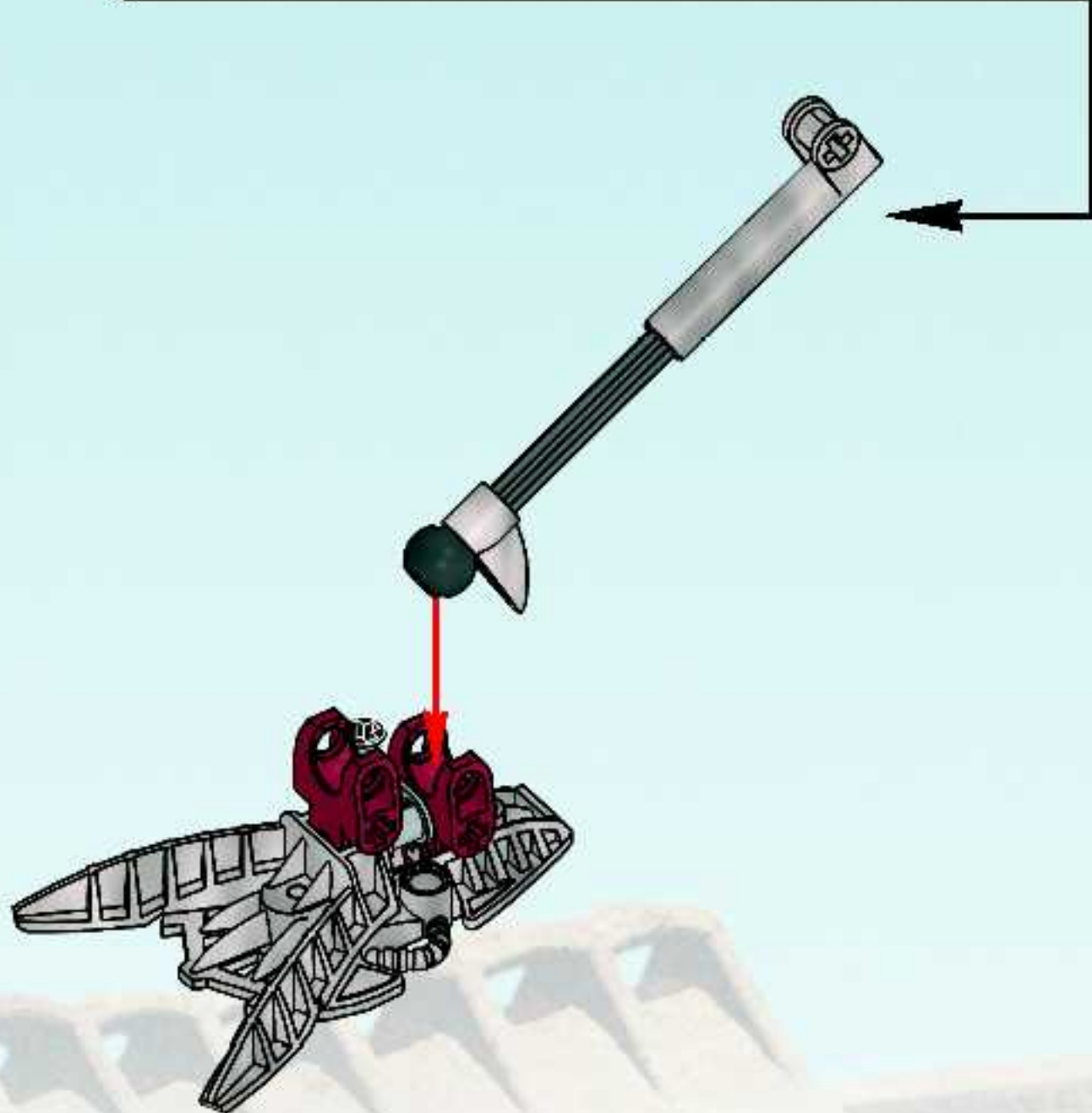
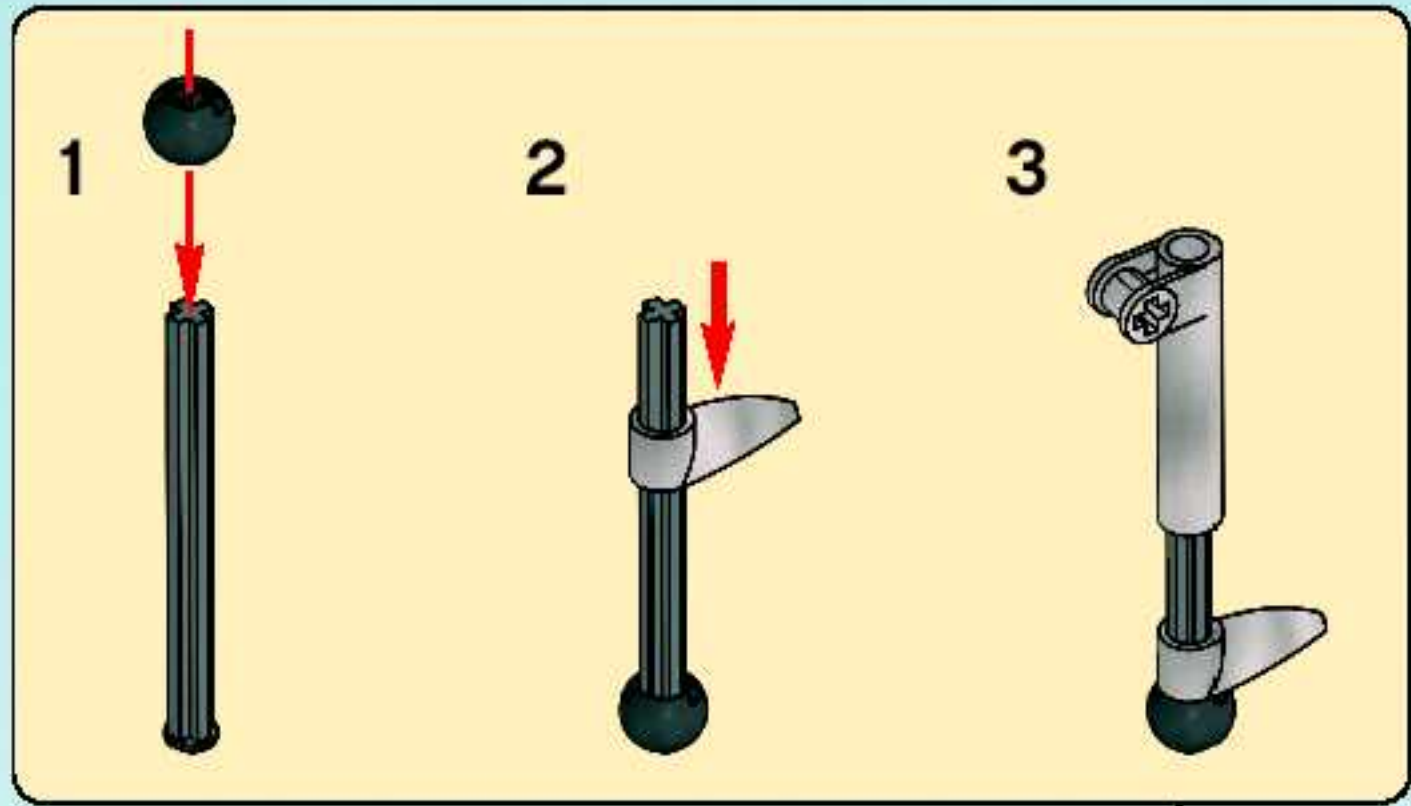



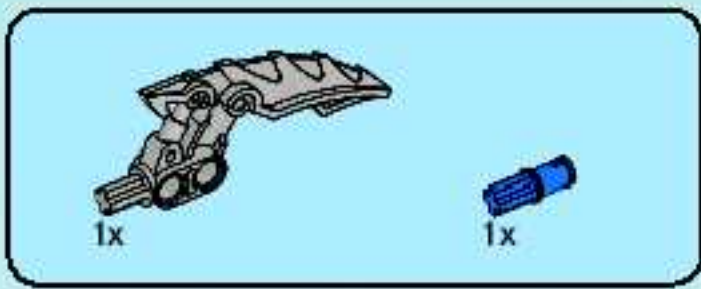

6

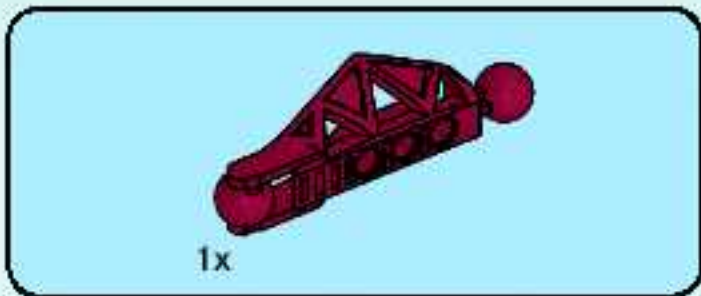
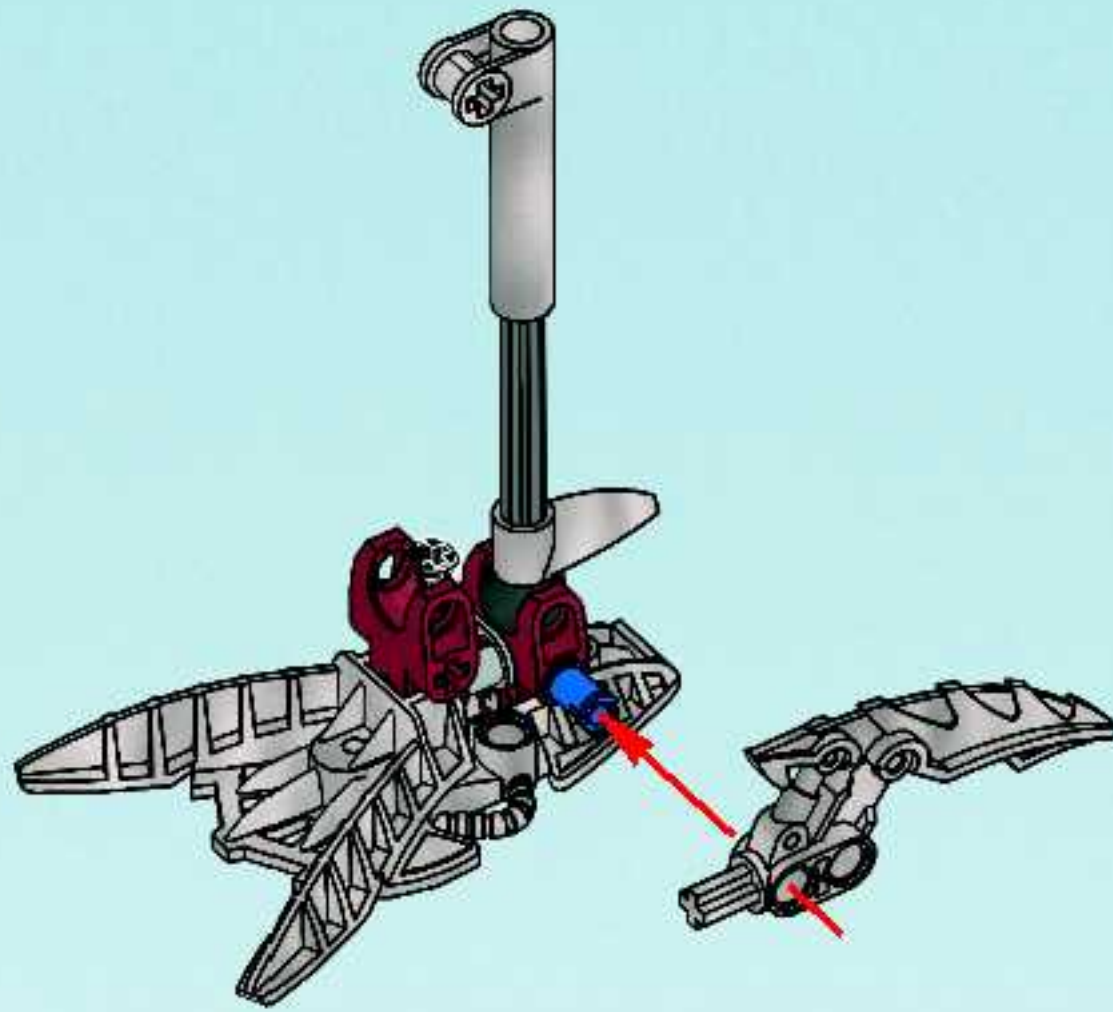

7

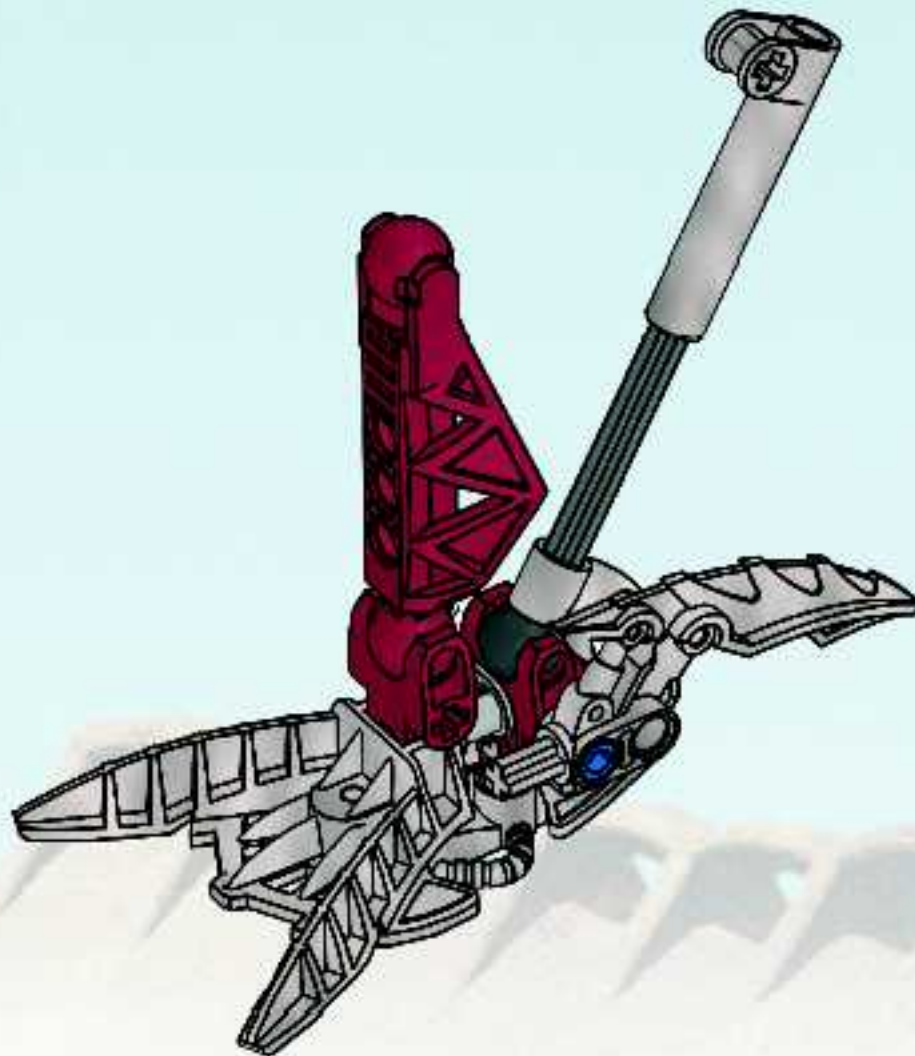

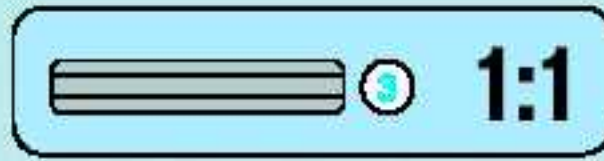
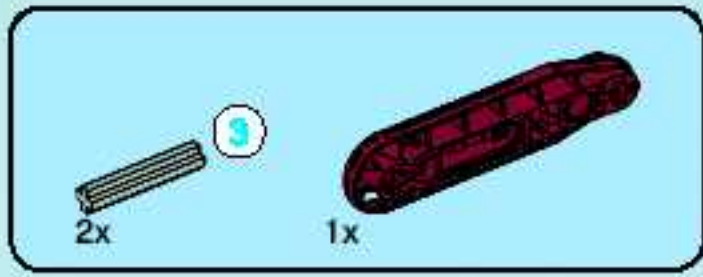
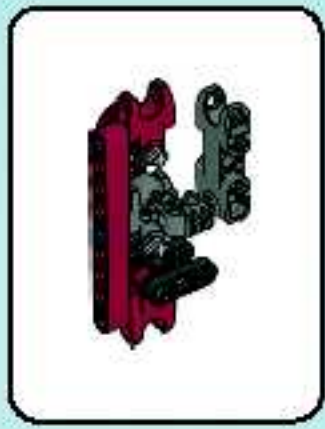

1

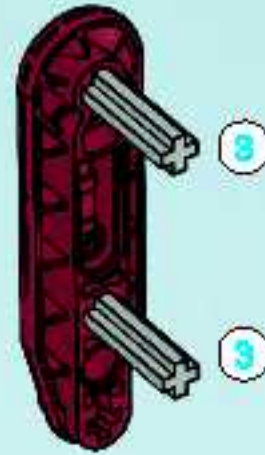

2

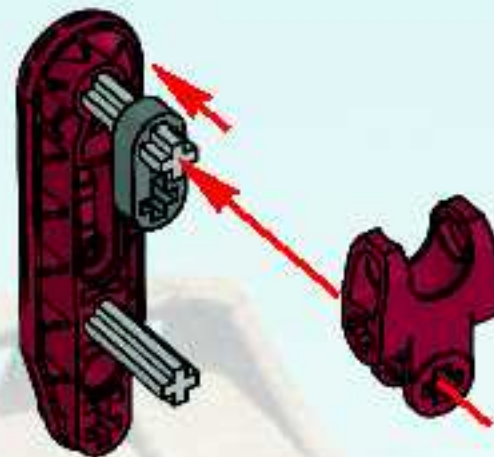





3

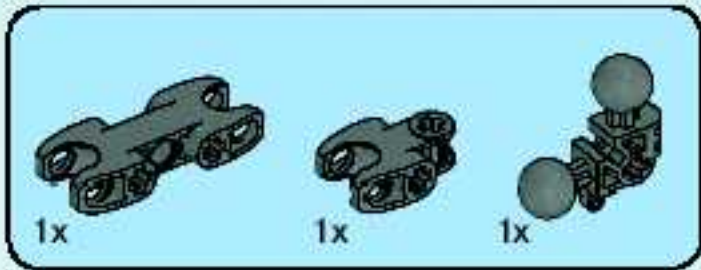

4

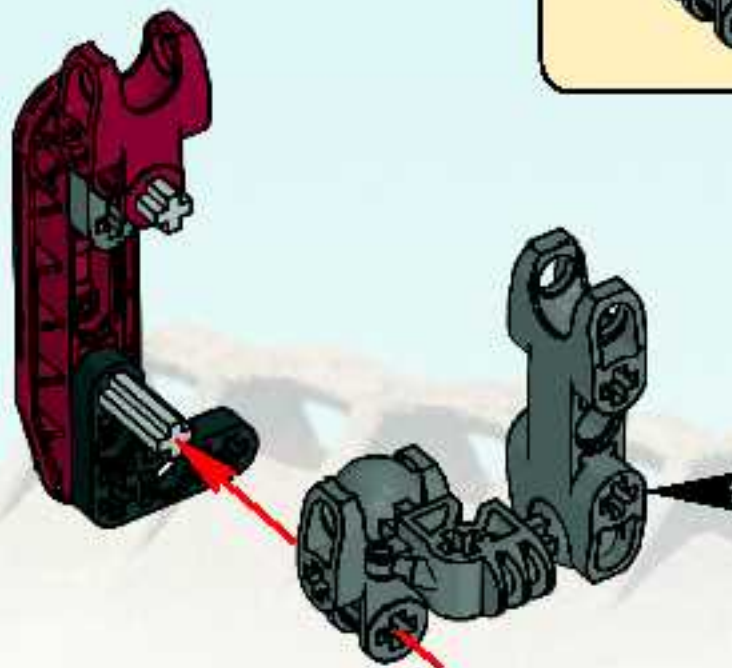
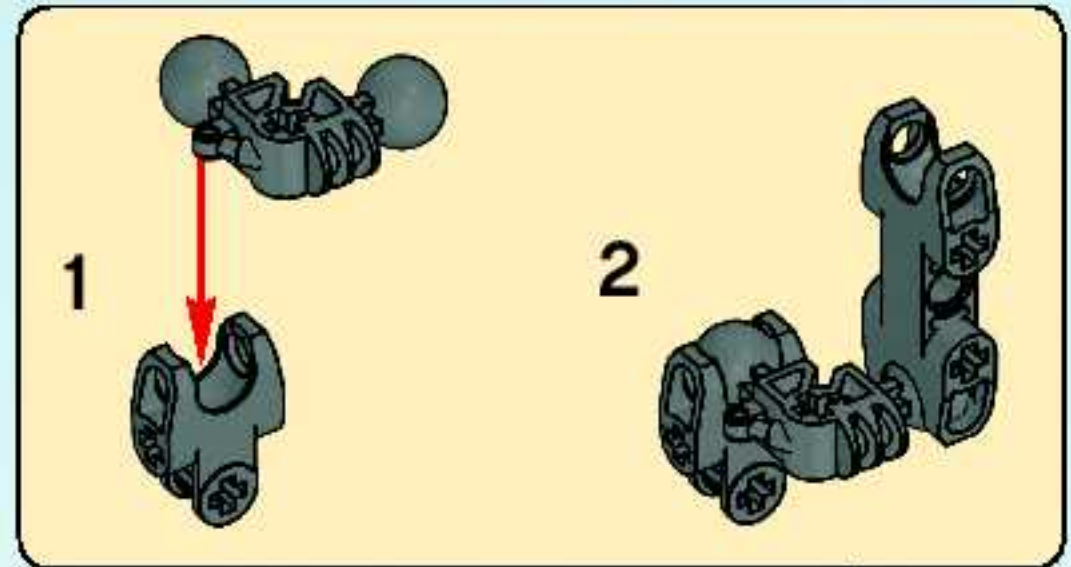

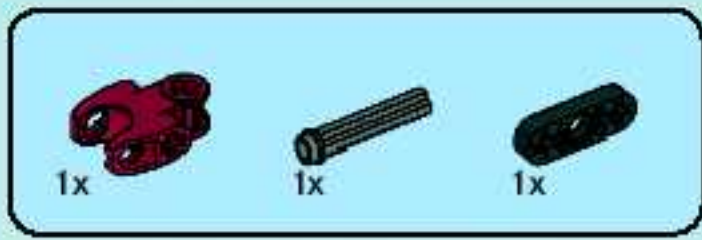

5

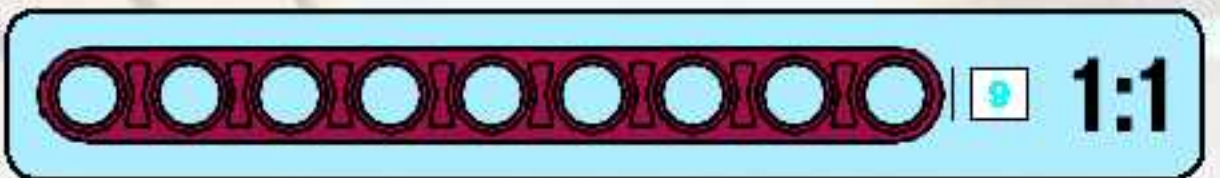
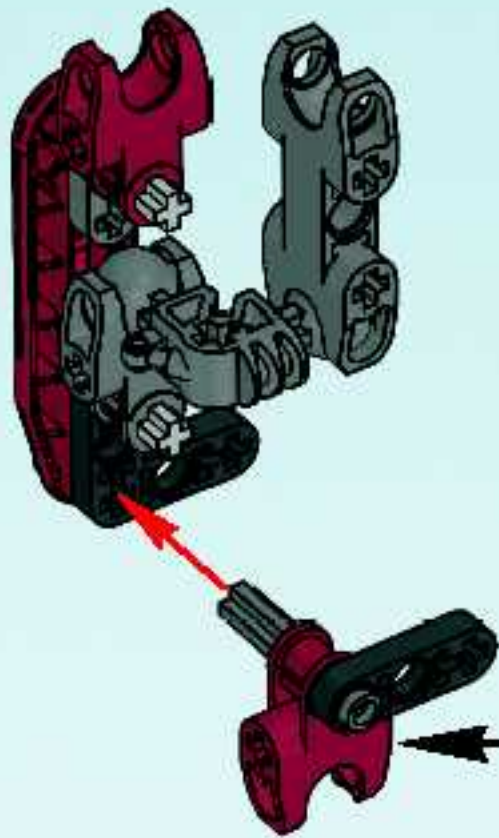
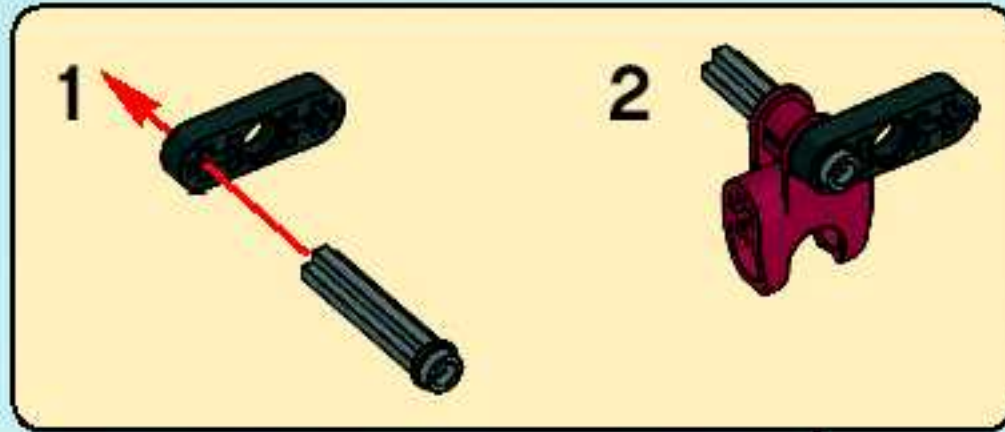



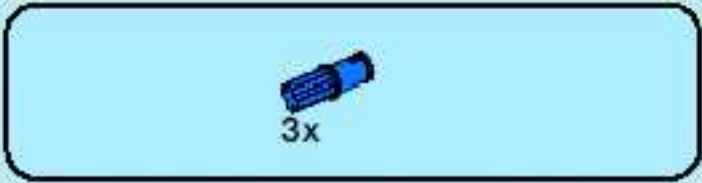

6

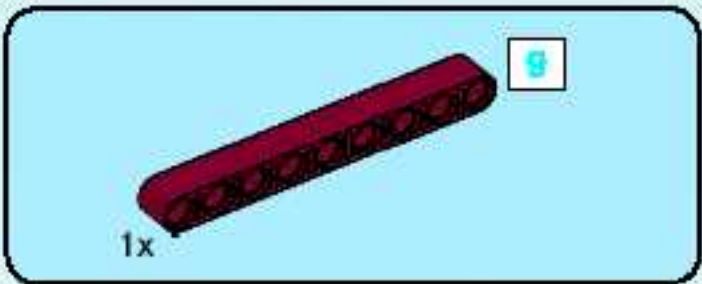
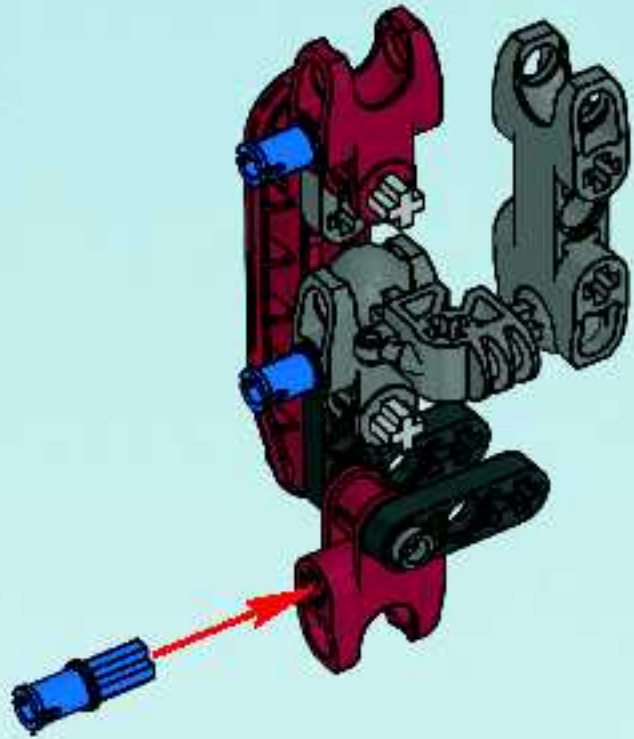

7

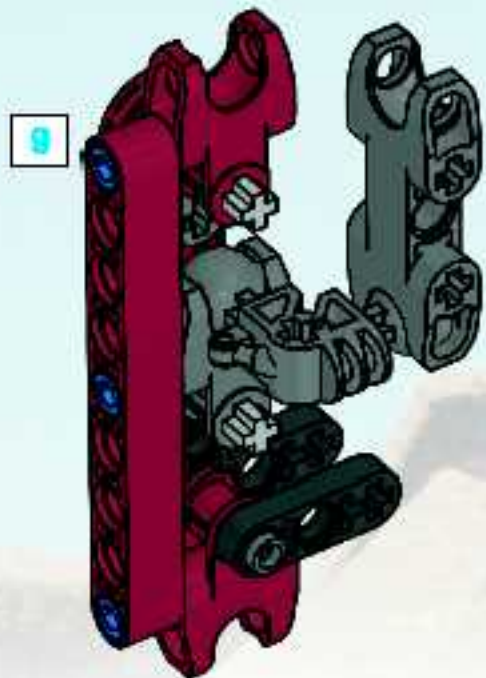

8

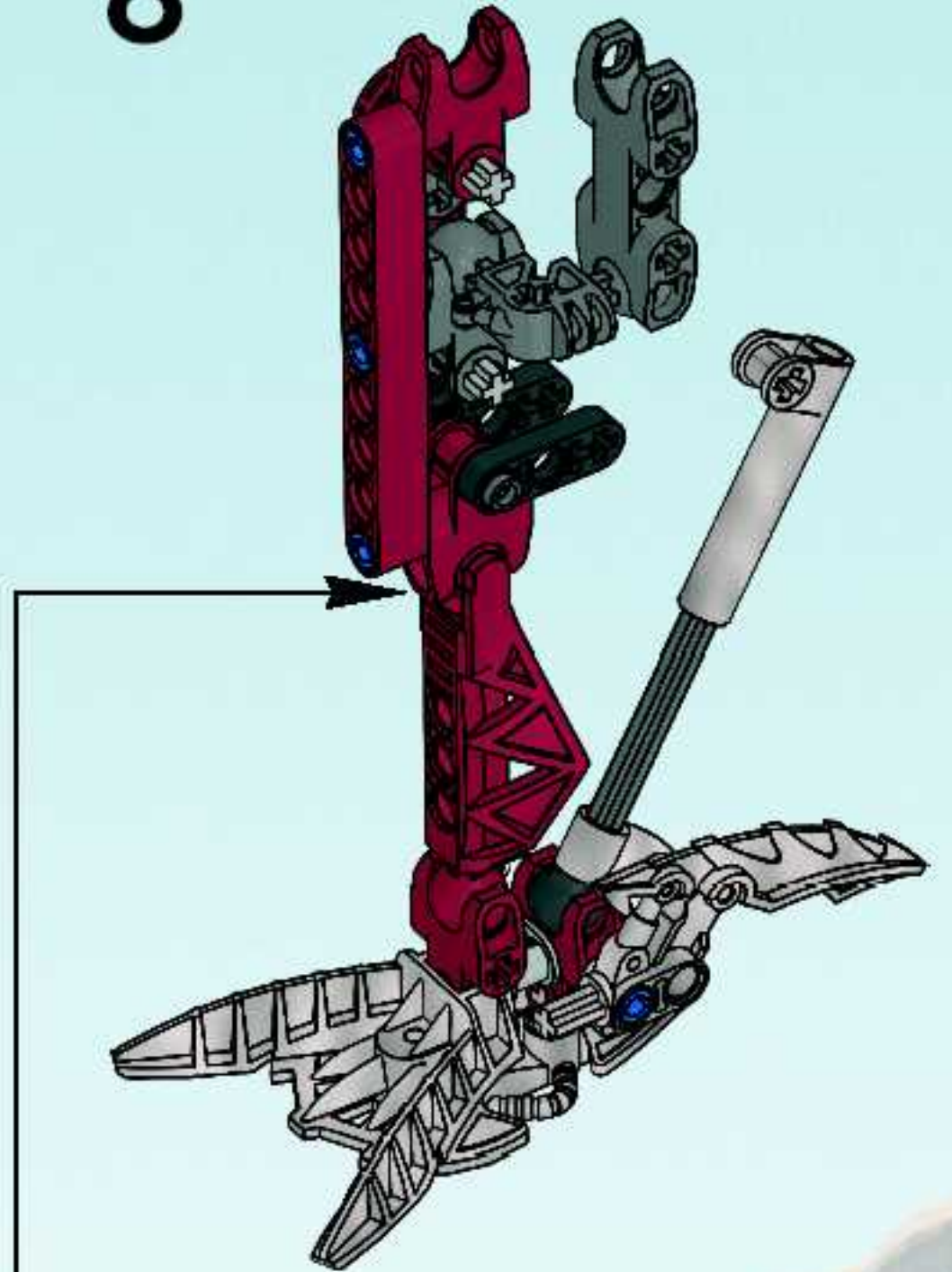

9

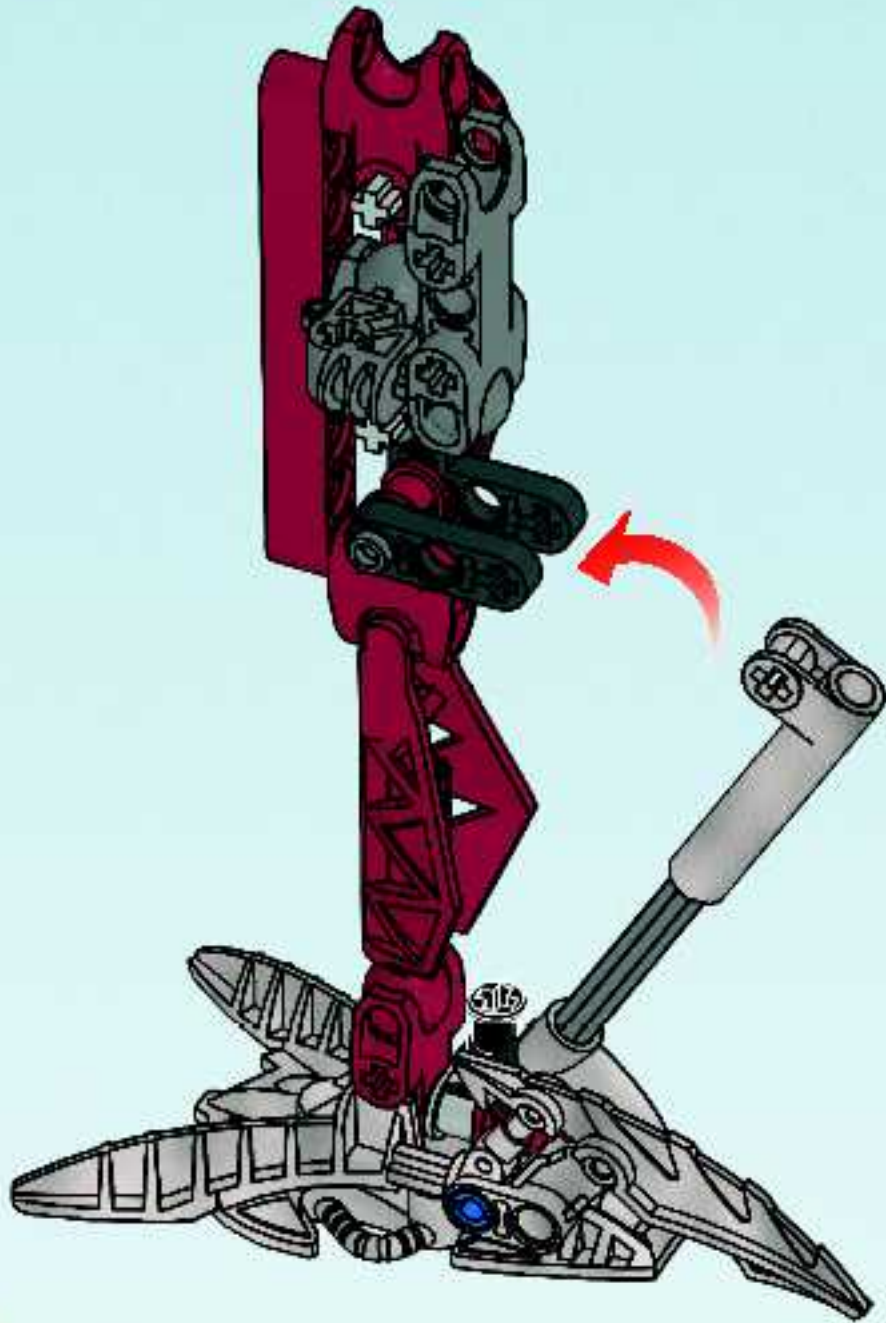

10

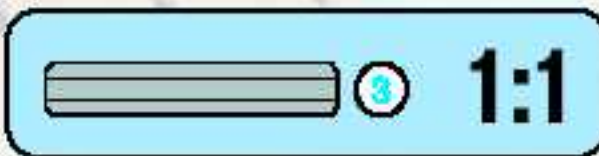
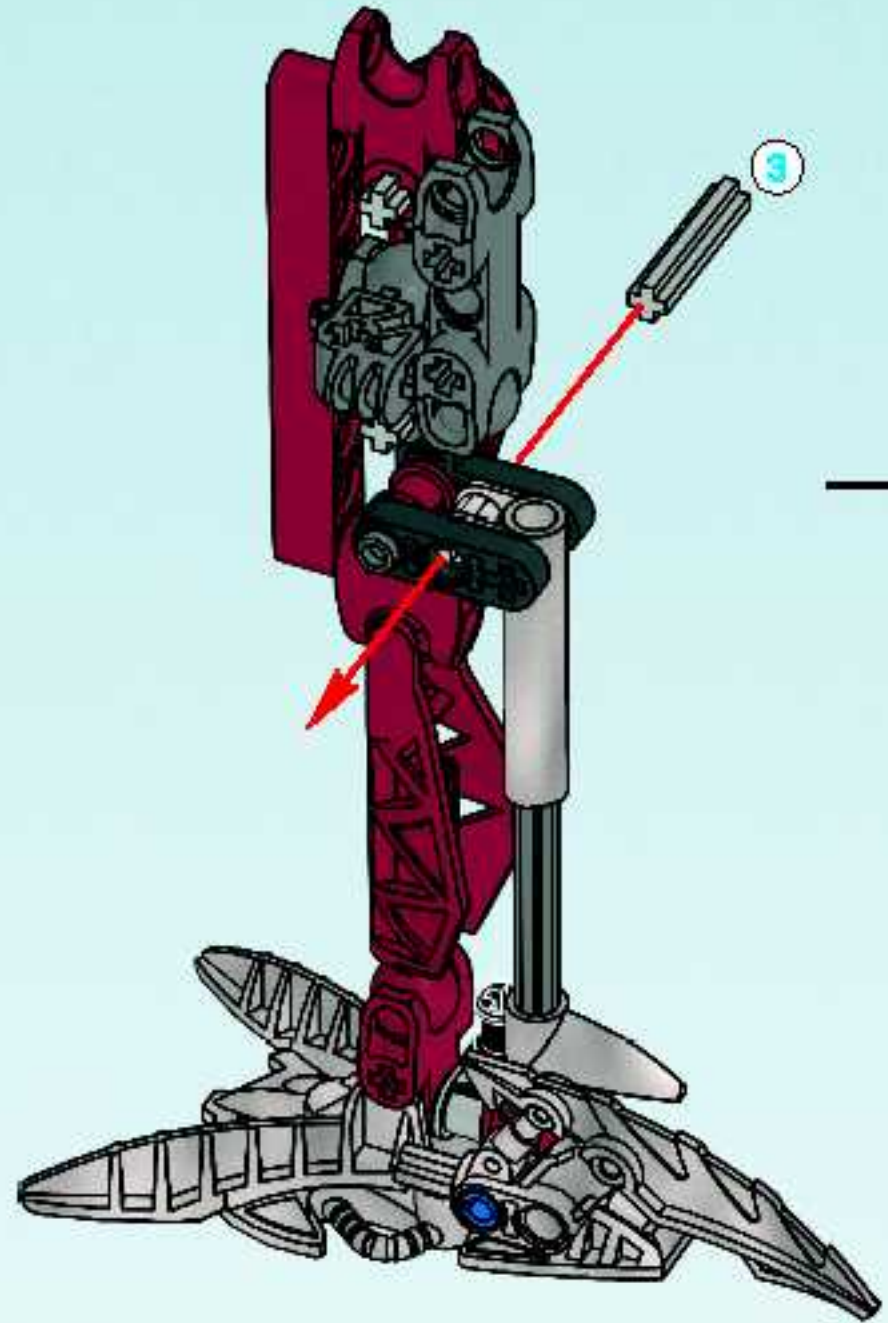
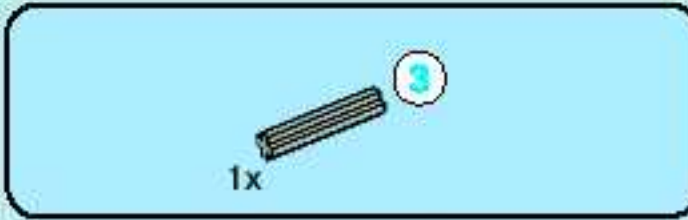



11

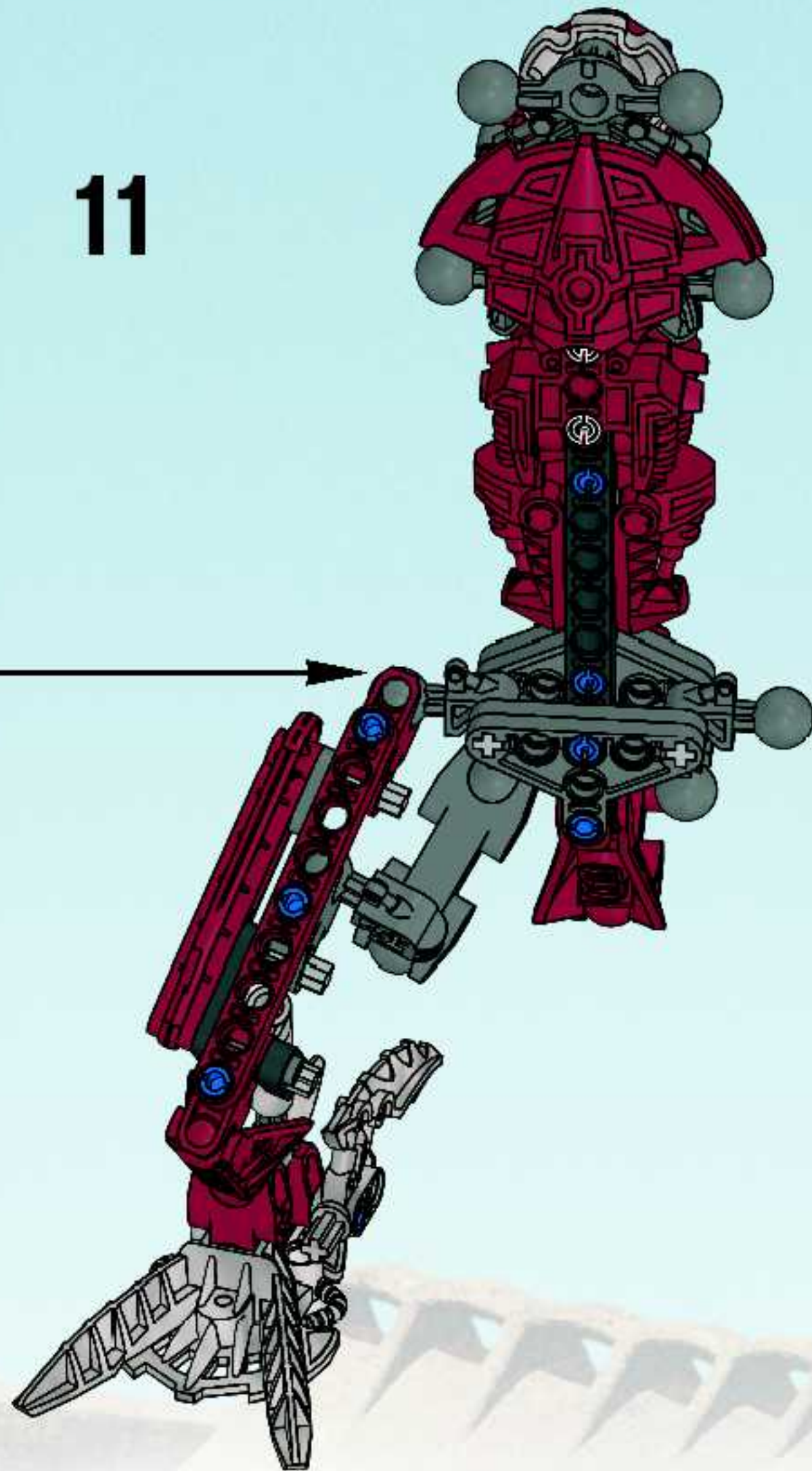

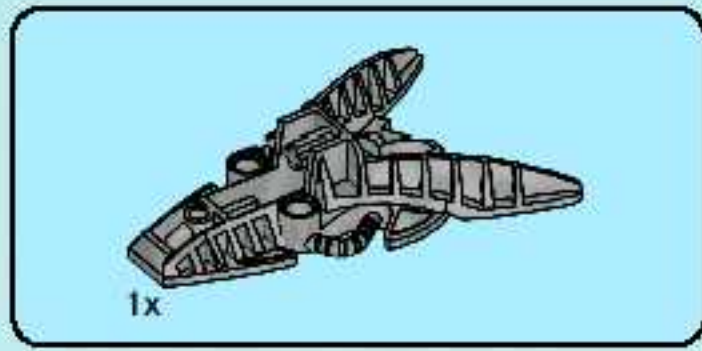
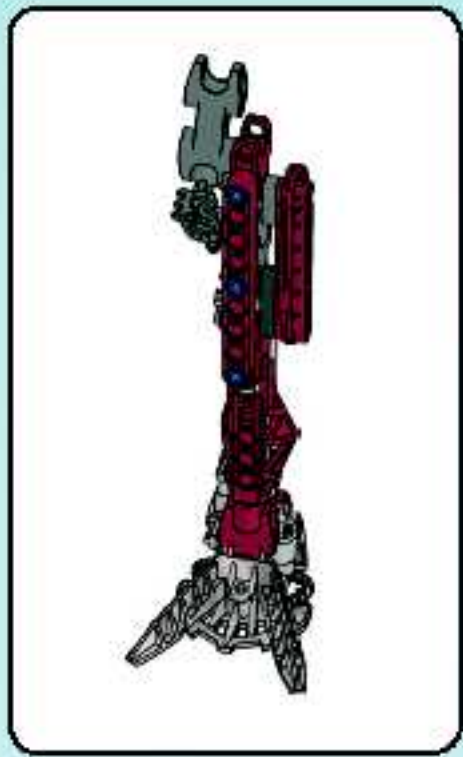

1

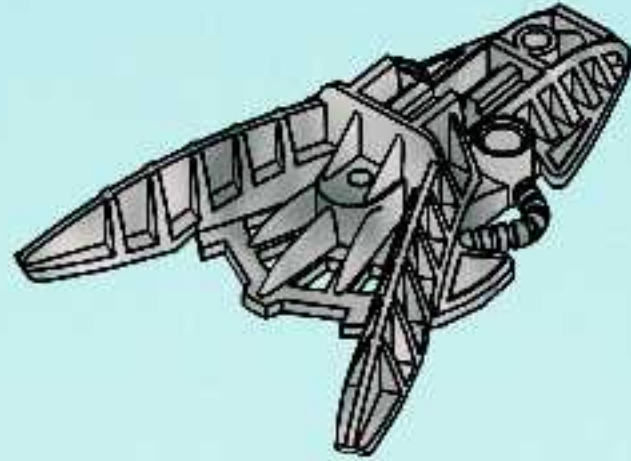

2

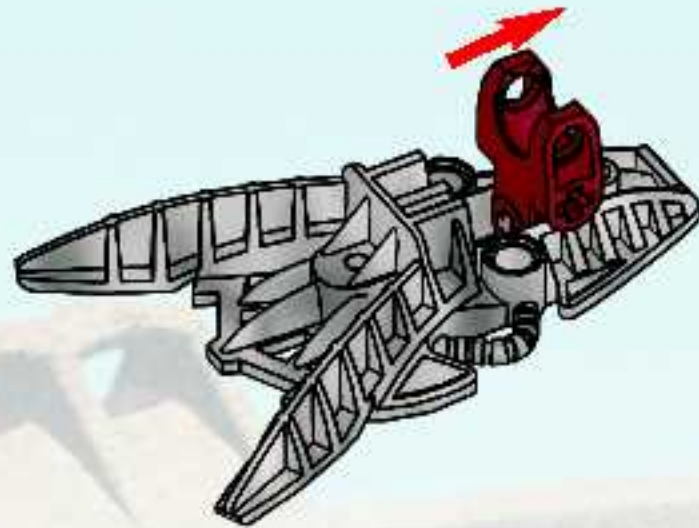



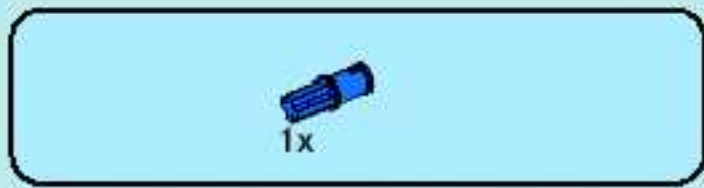

3

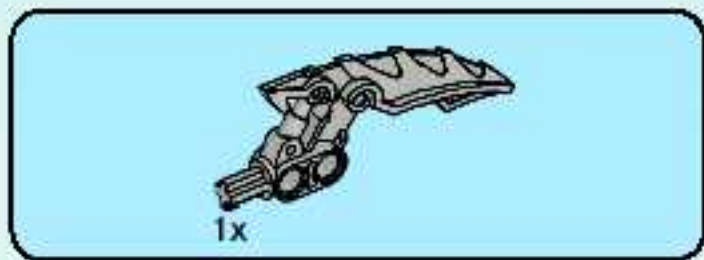
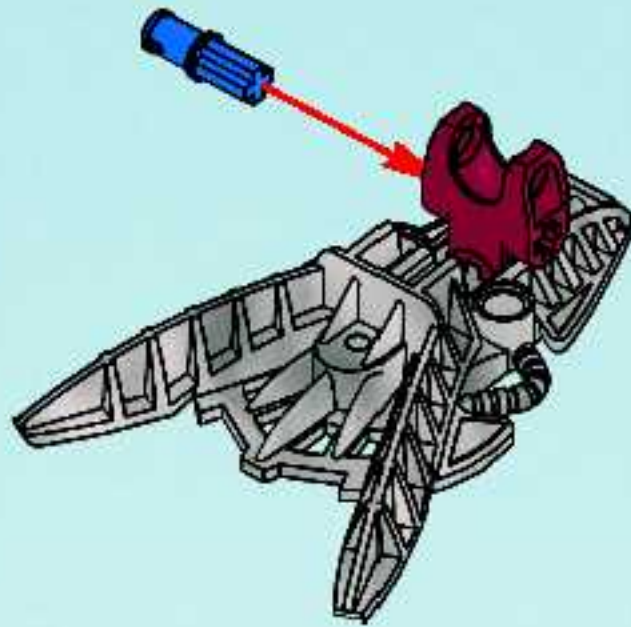

4

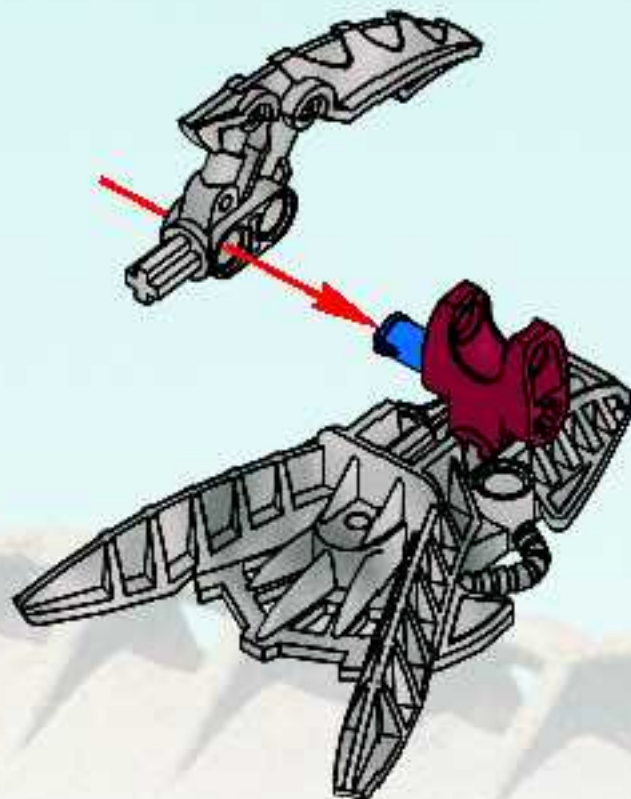



5

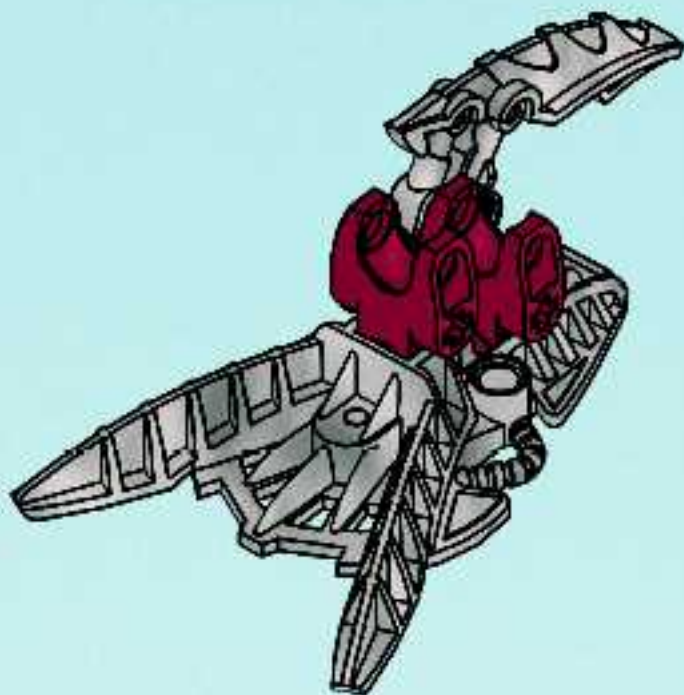

6

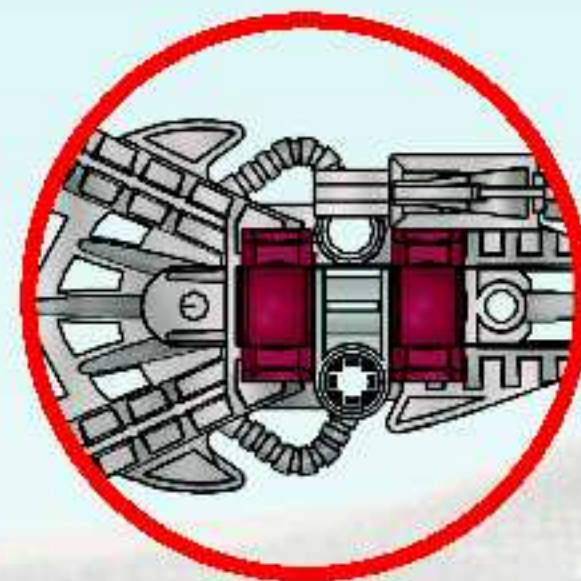
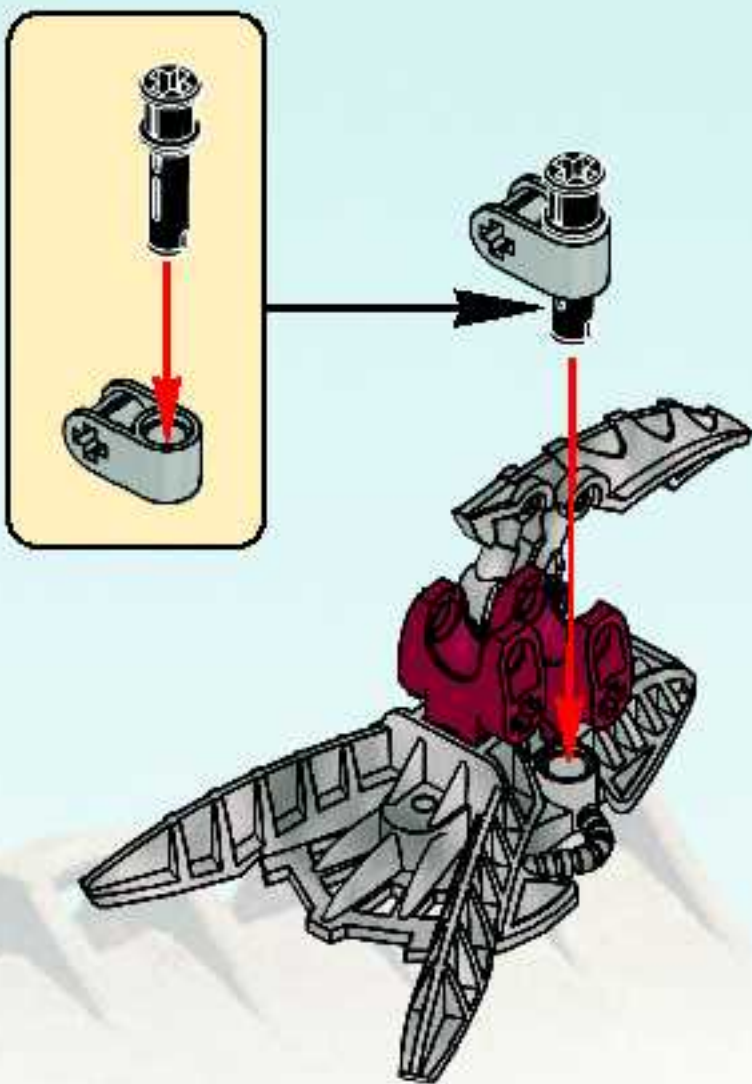



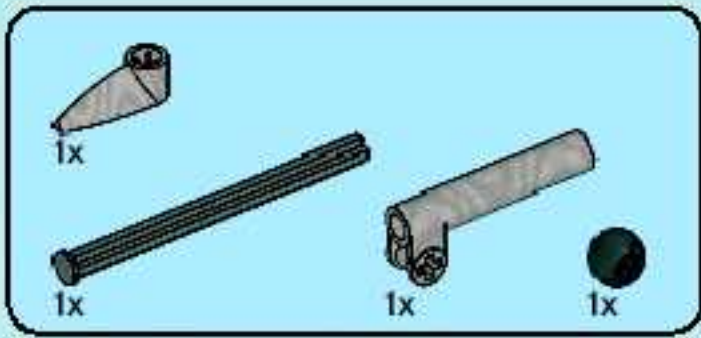

7

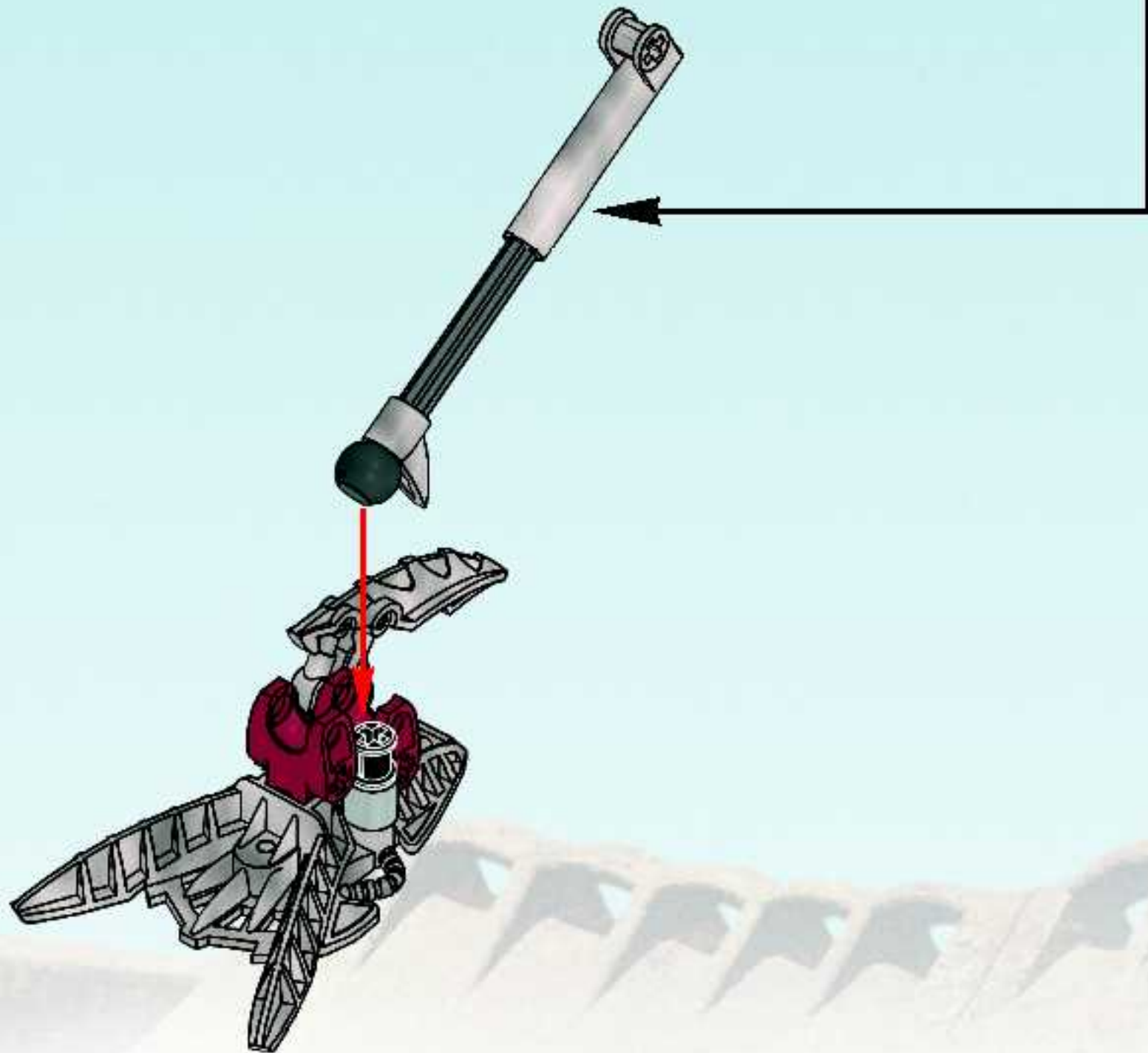
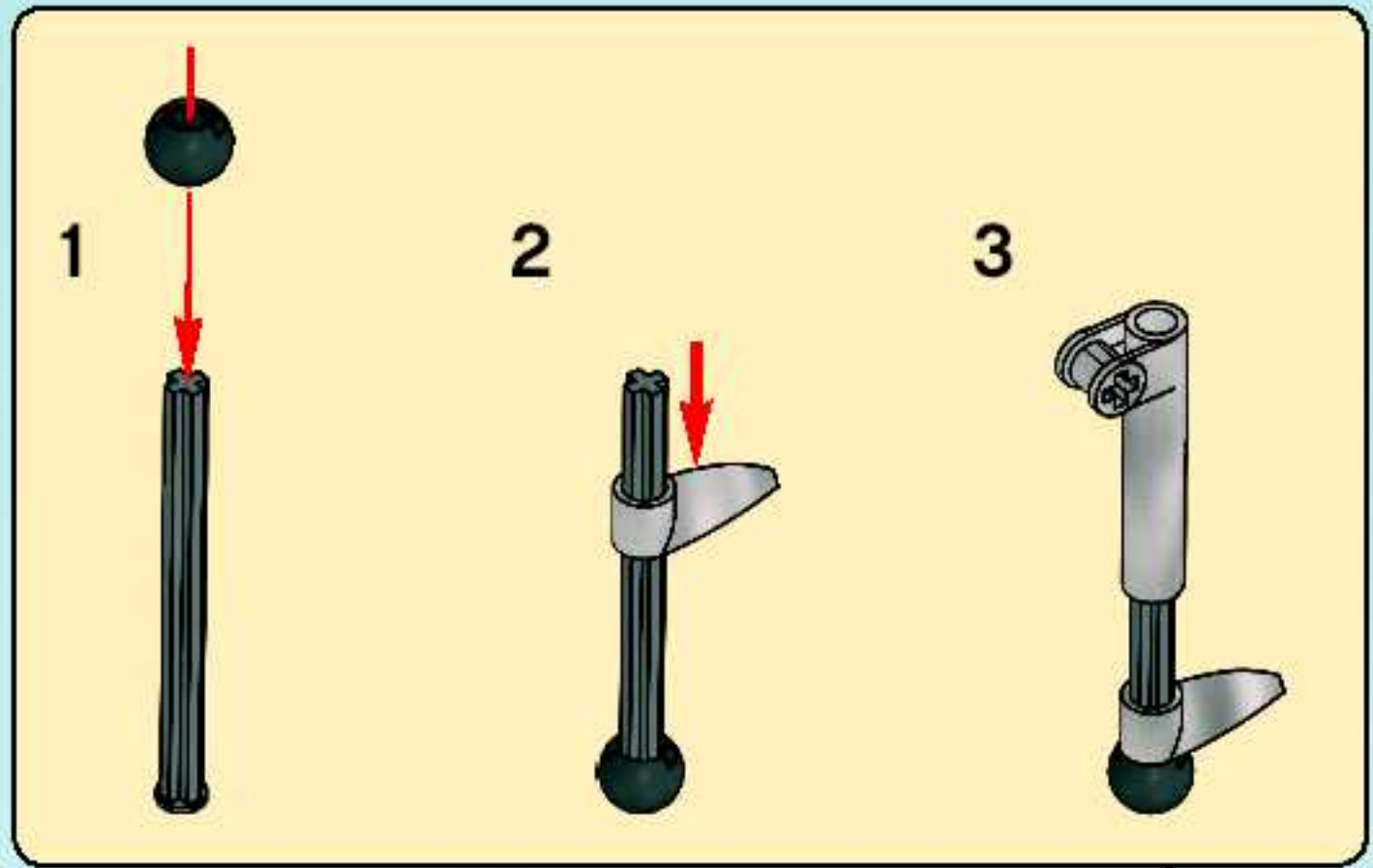

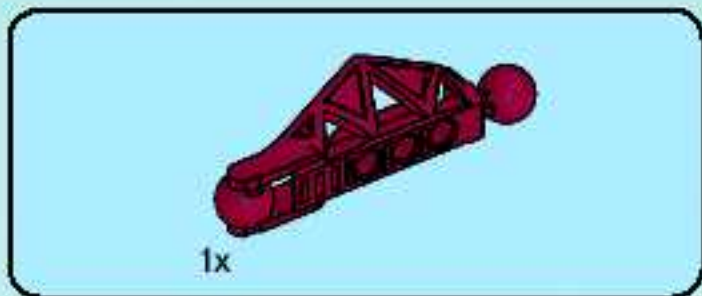

8

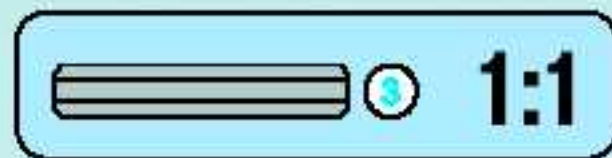
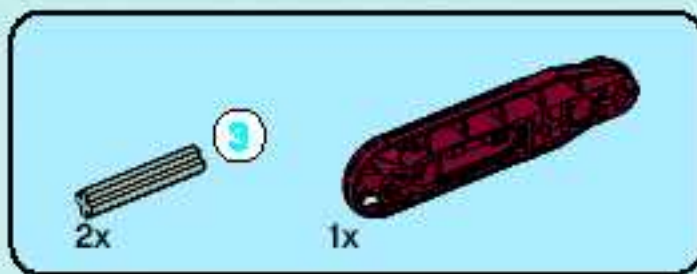
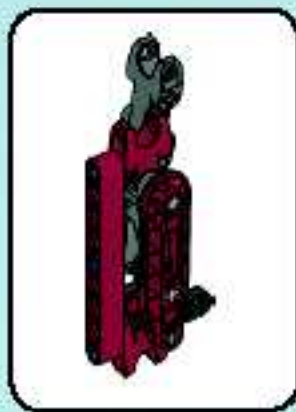

1

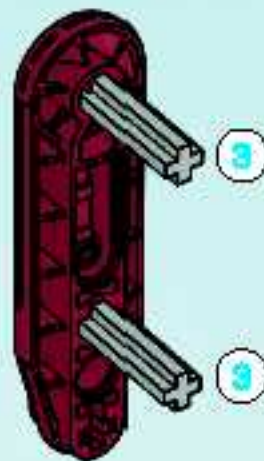

2

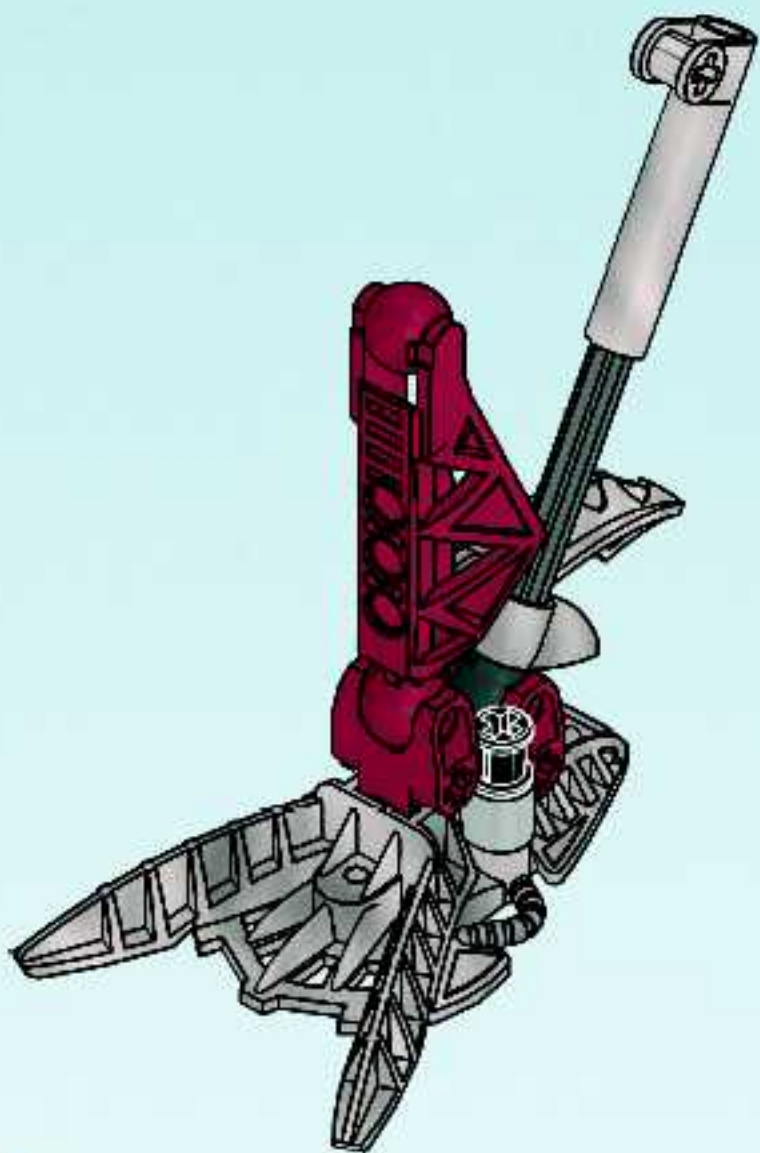
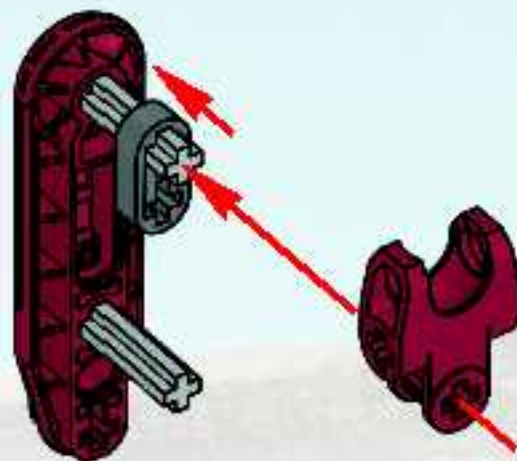





3

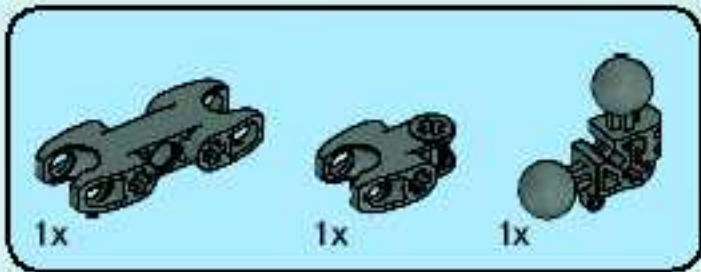
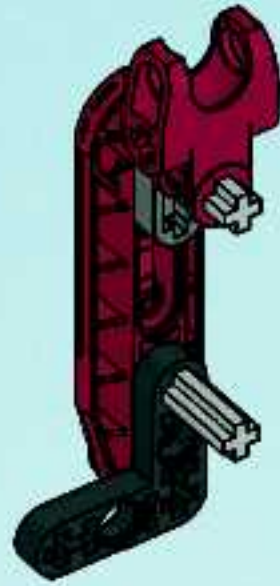

4

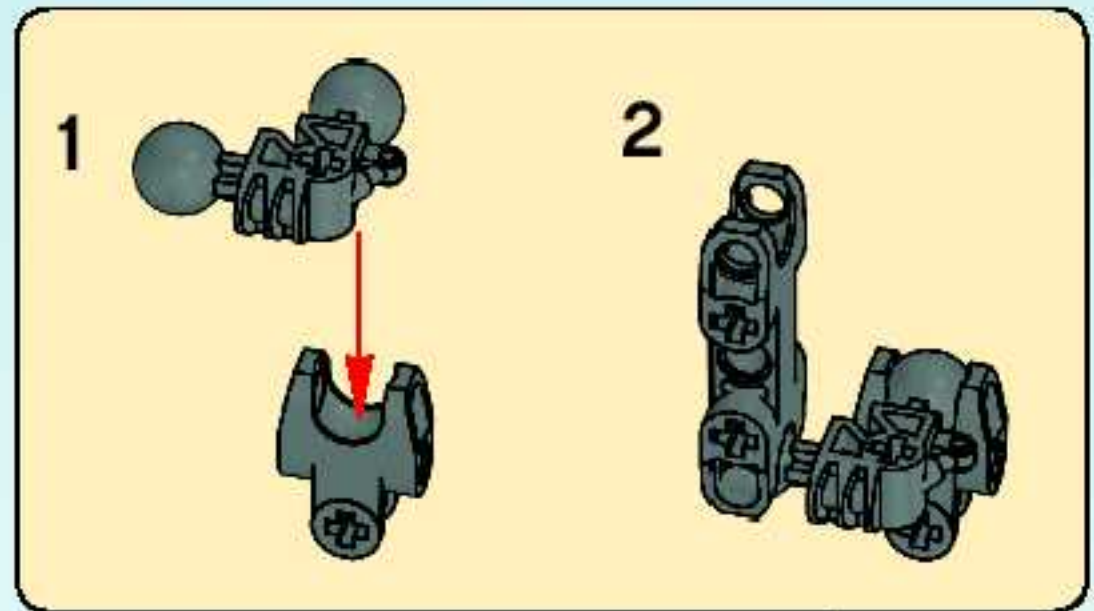
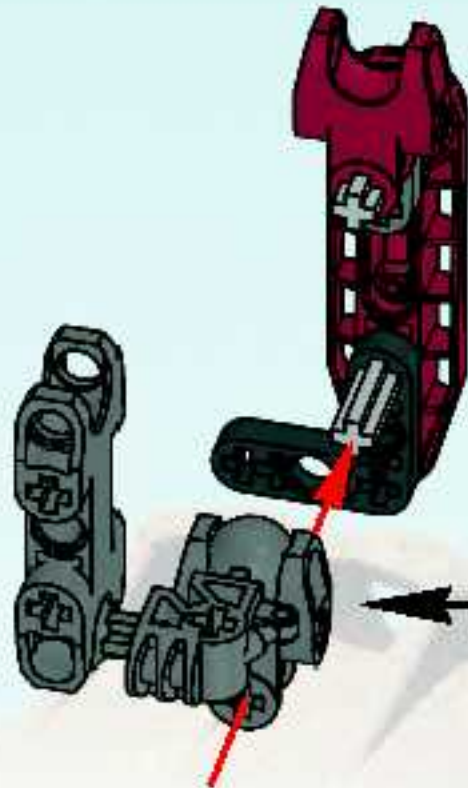

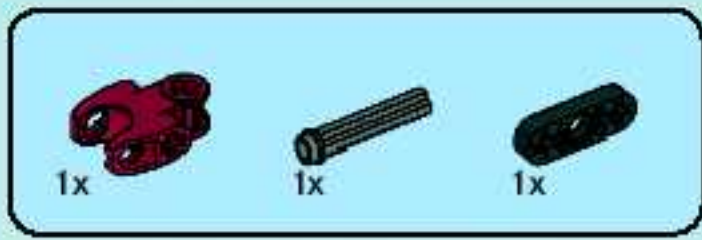

5

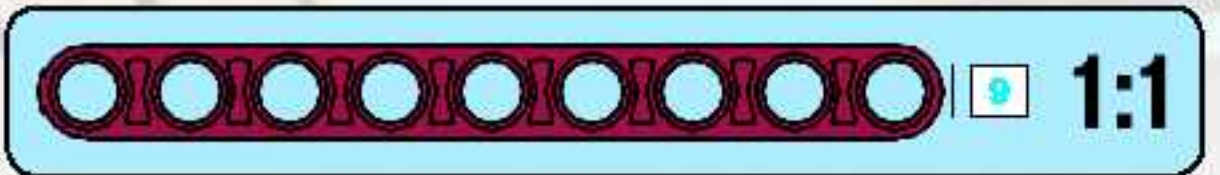
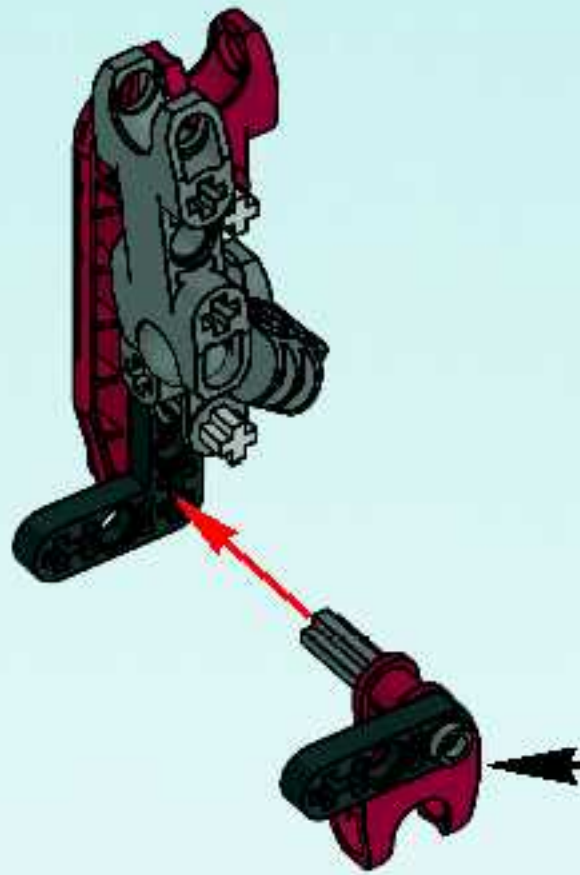
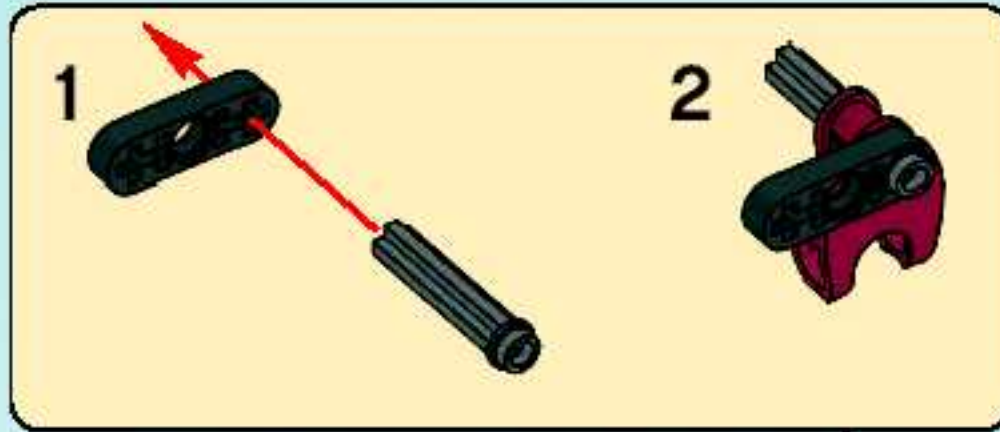



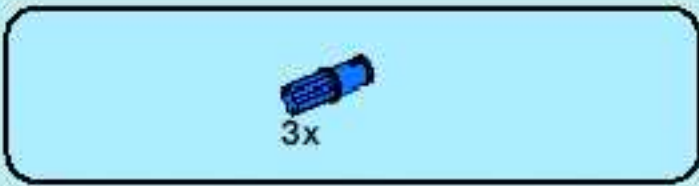

6

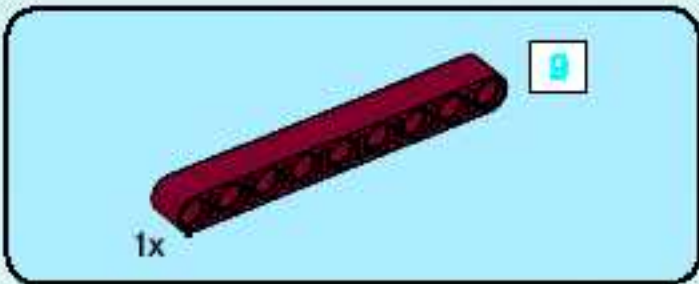

7

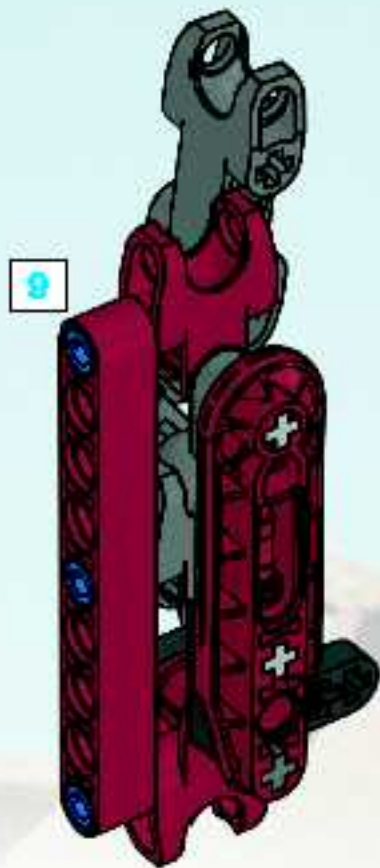

8

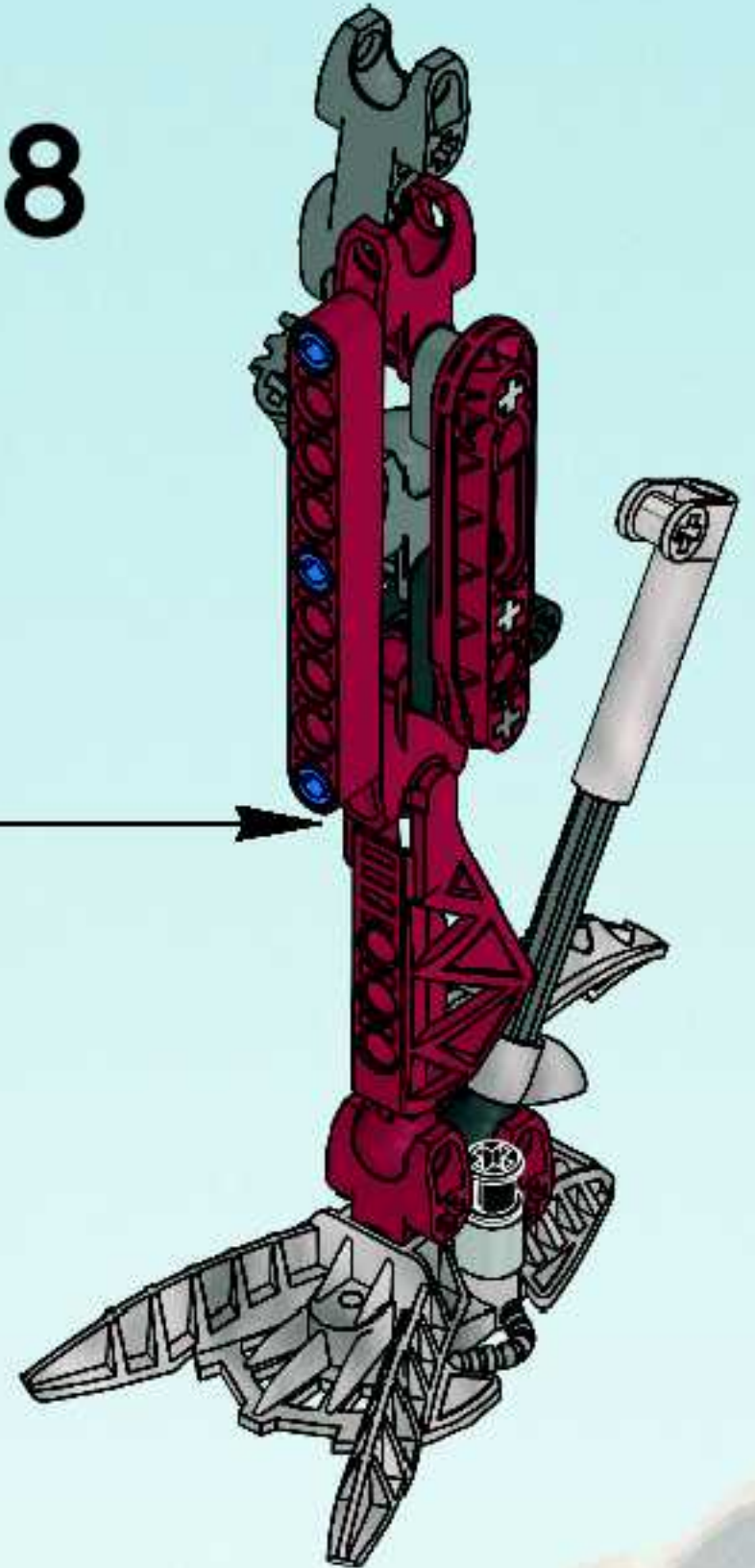

9

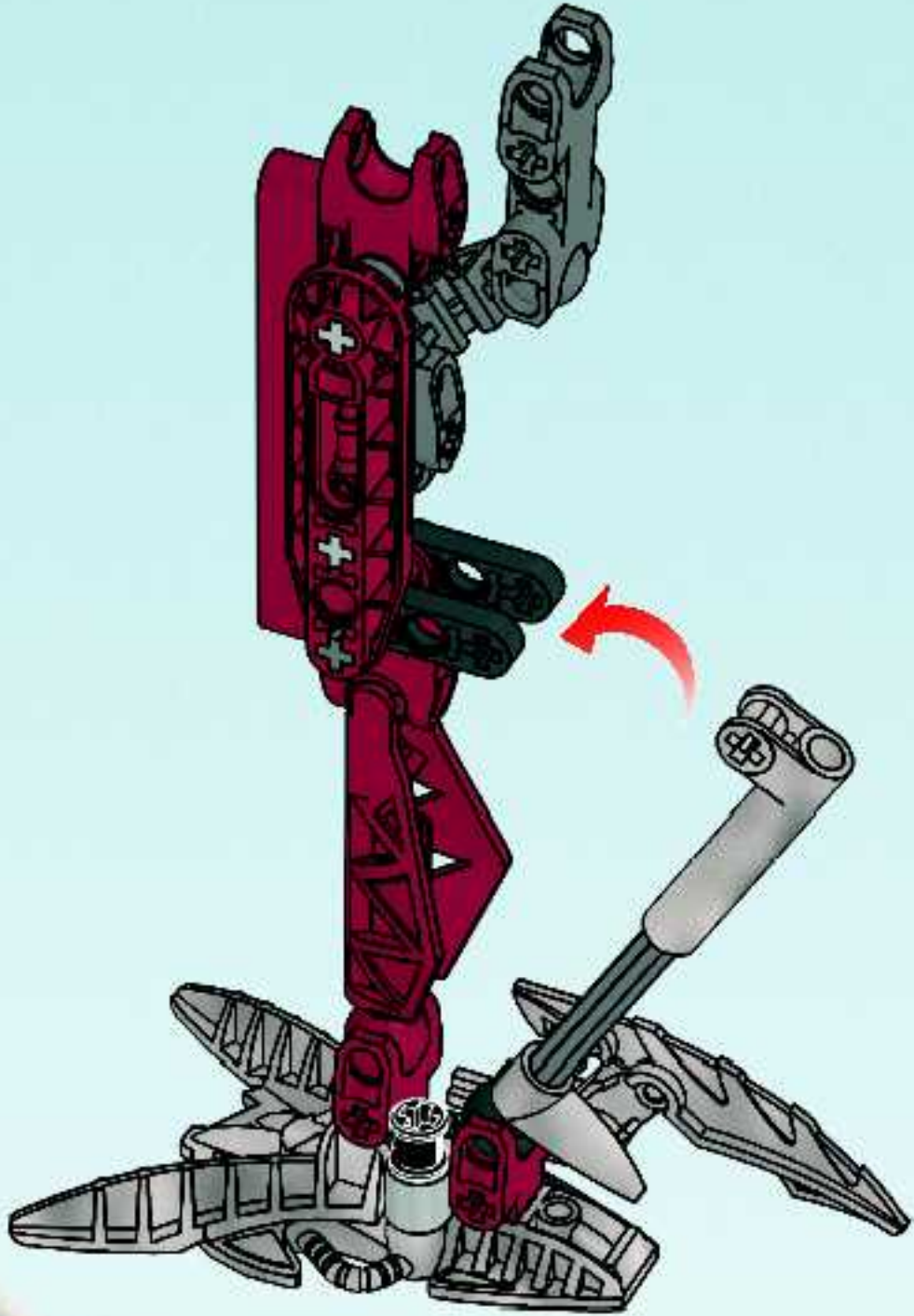

10

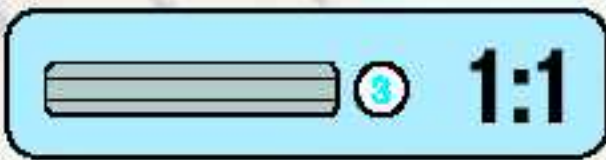
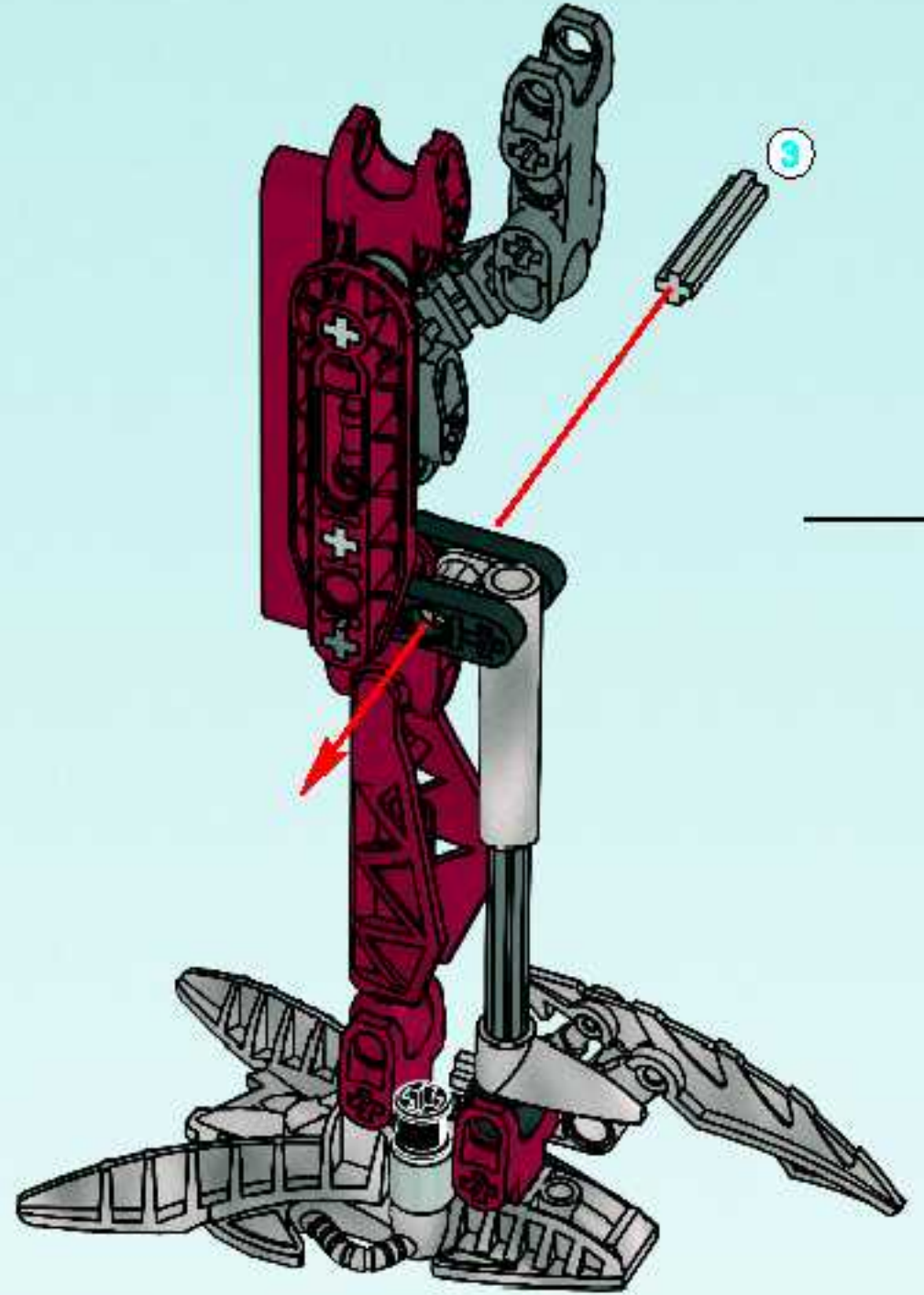
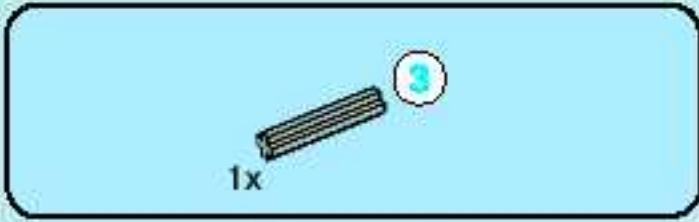



11

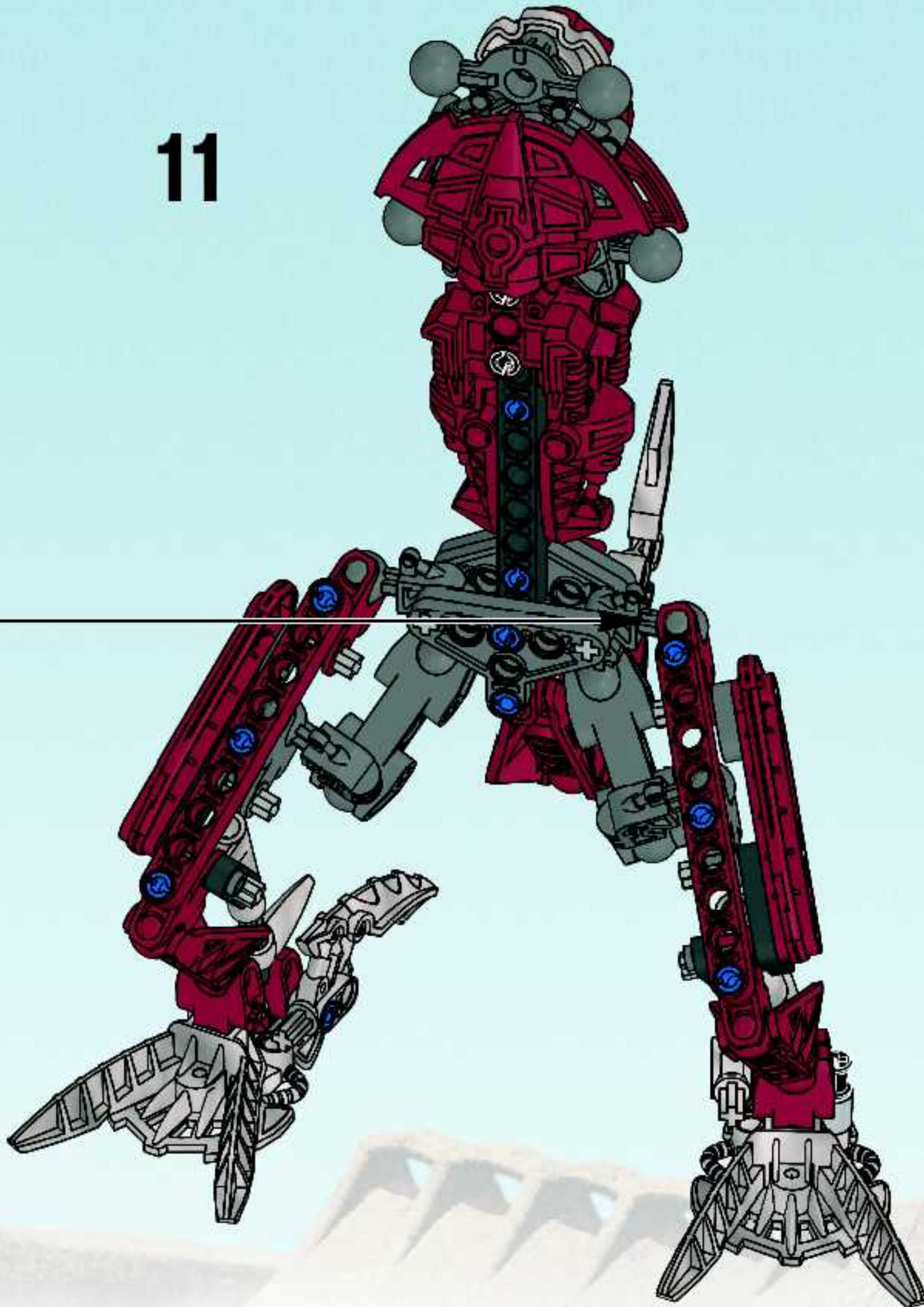



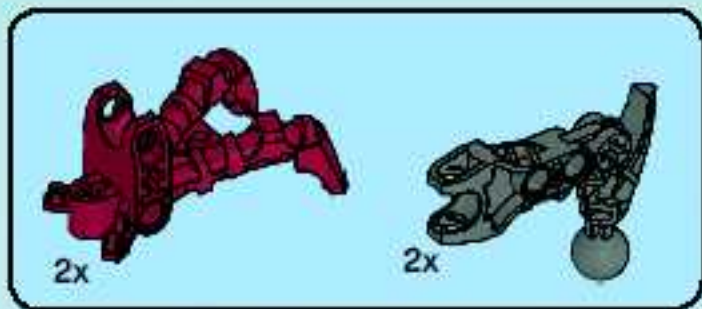

12

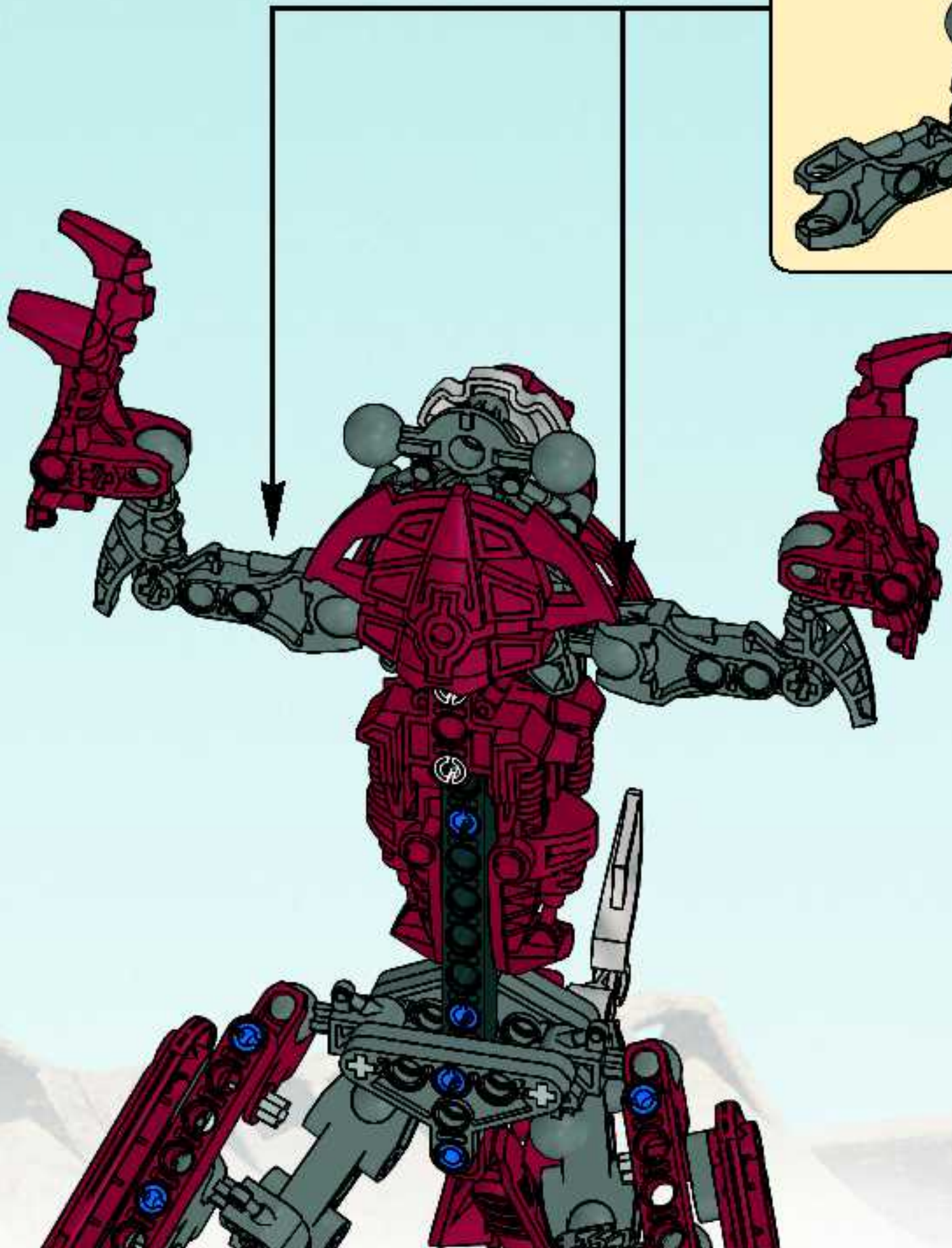
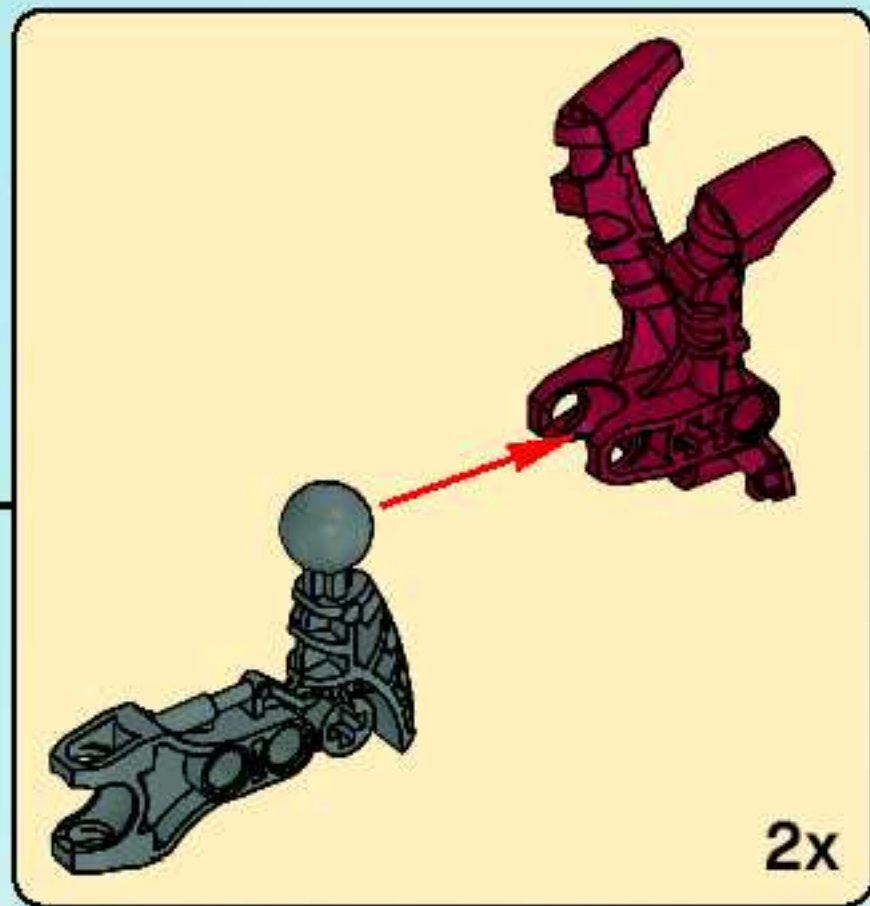



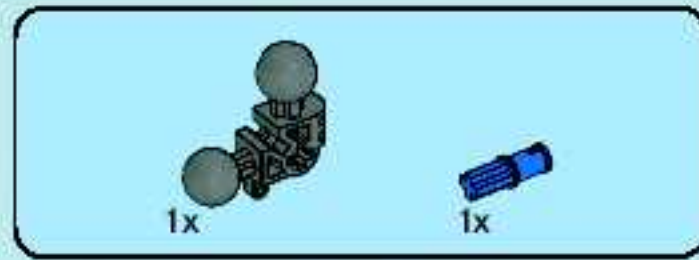
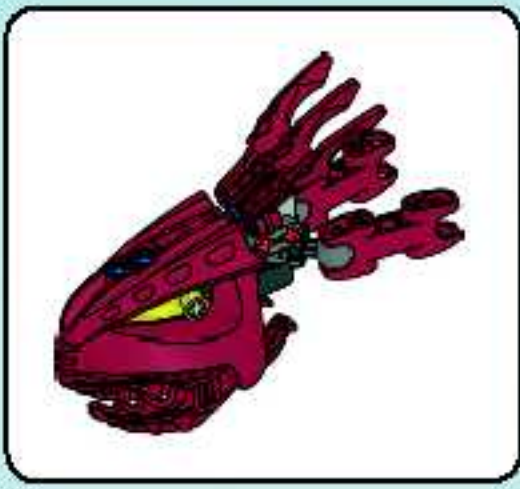

1

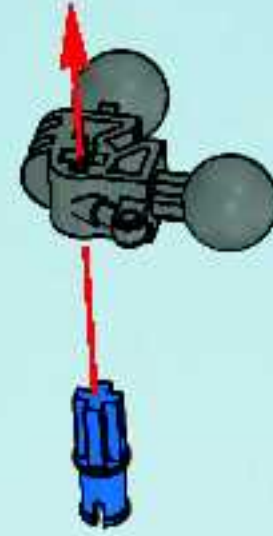

2

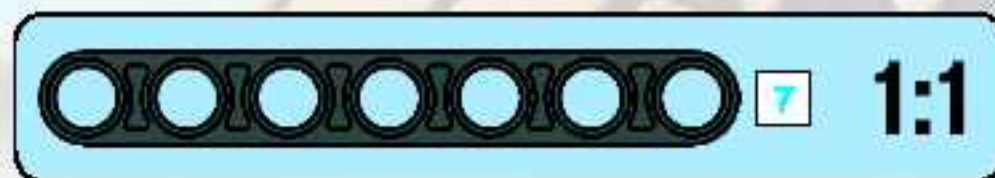
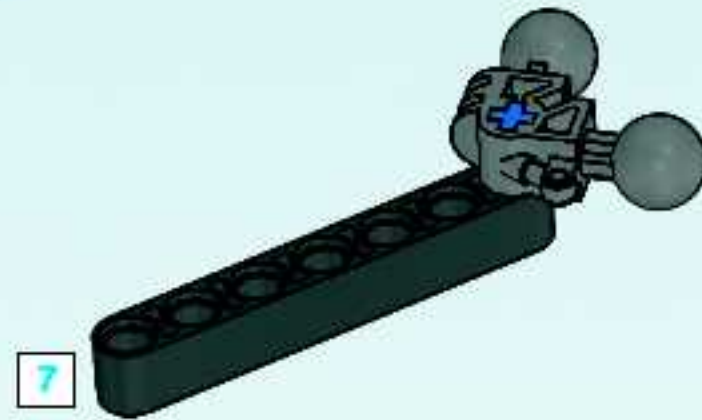

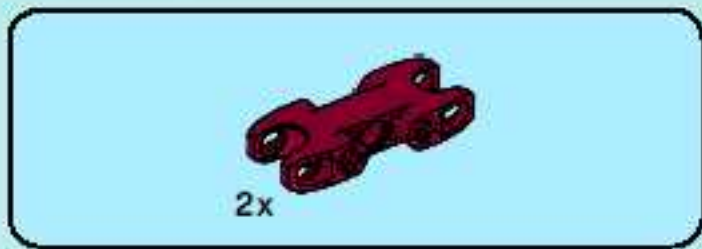

3

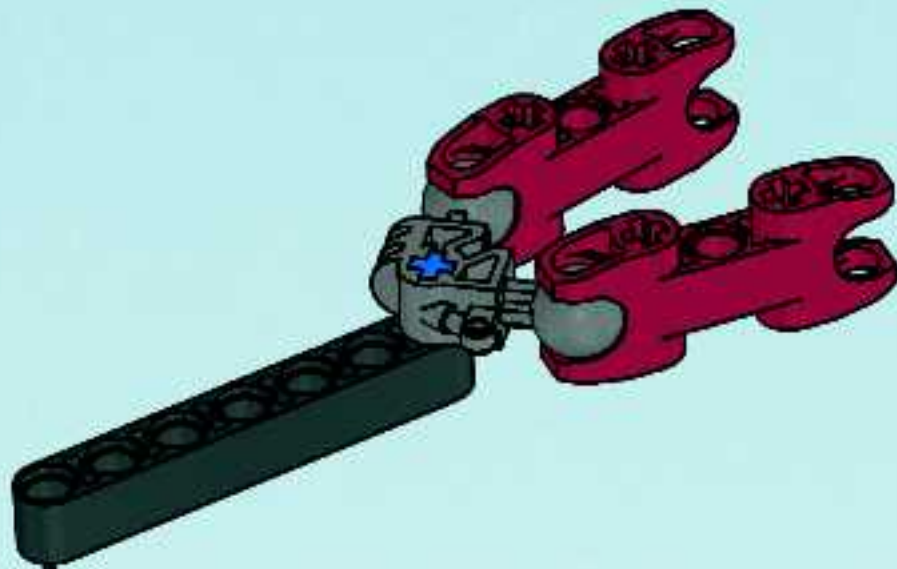

4

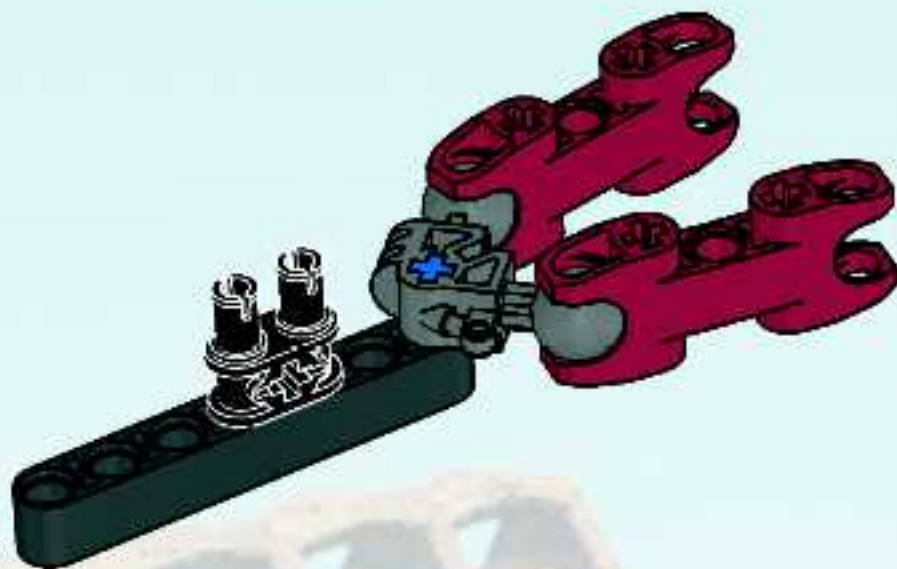



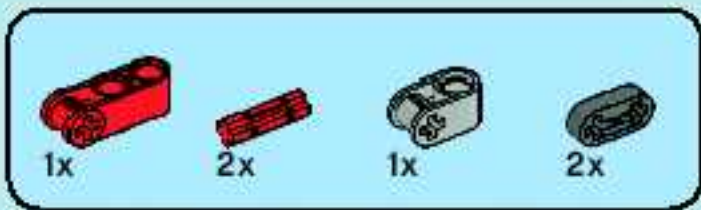

5

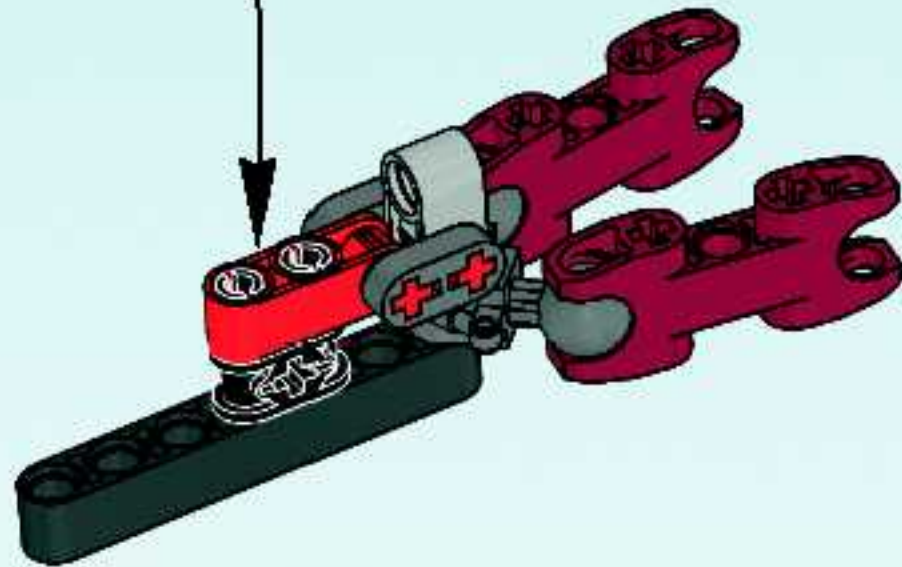
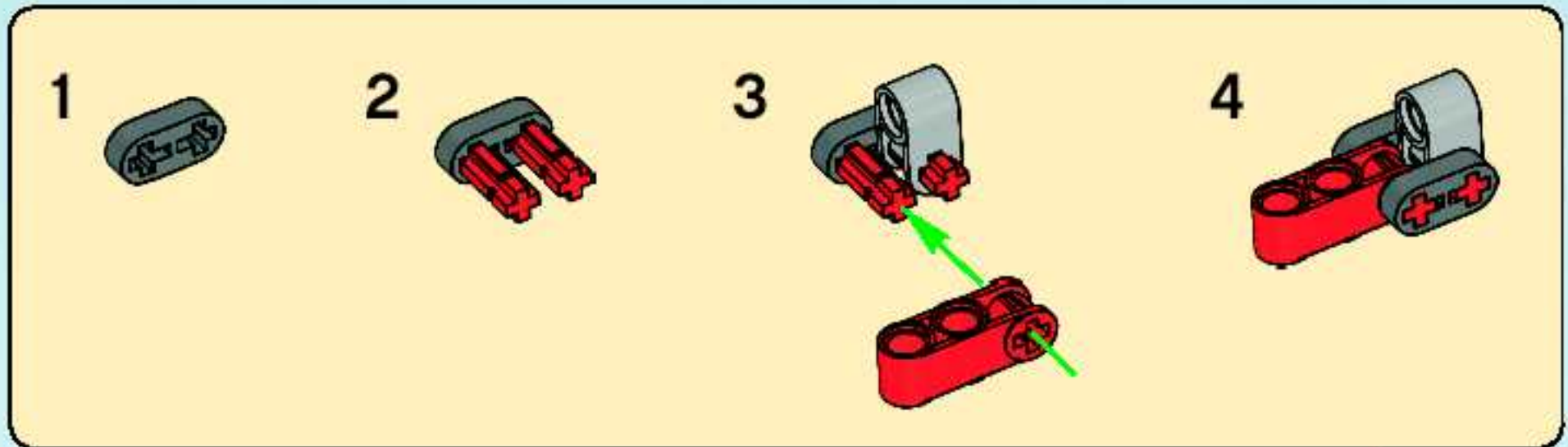

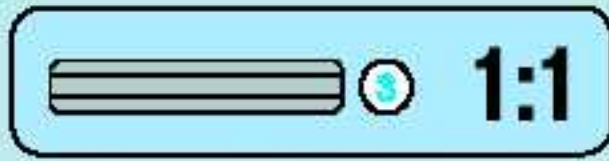
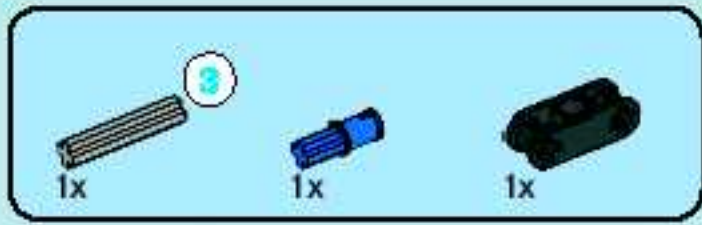

6

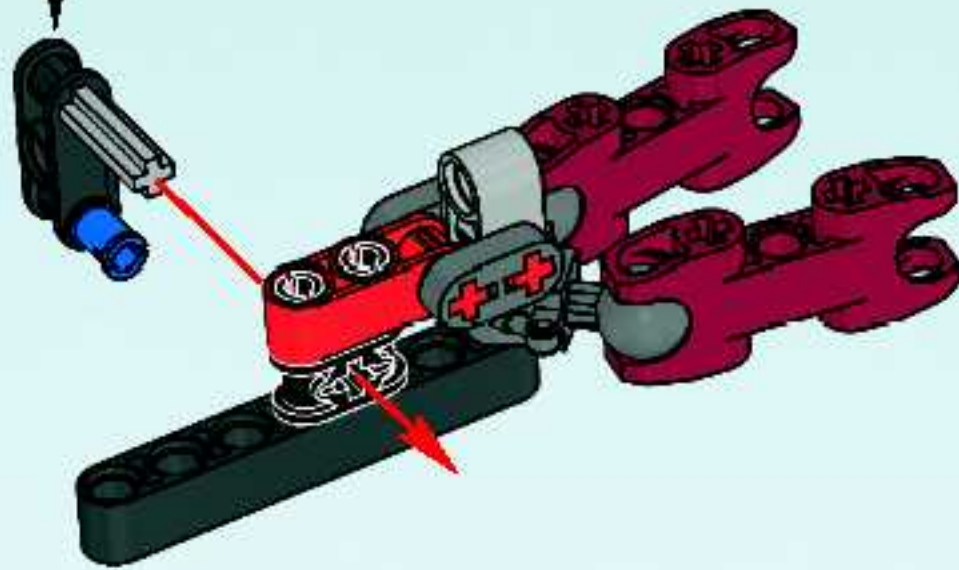
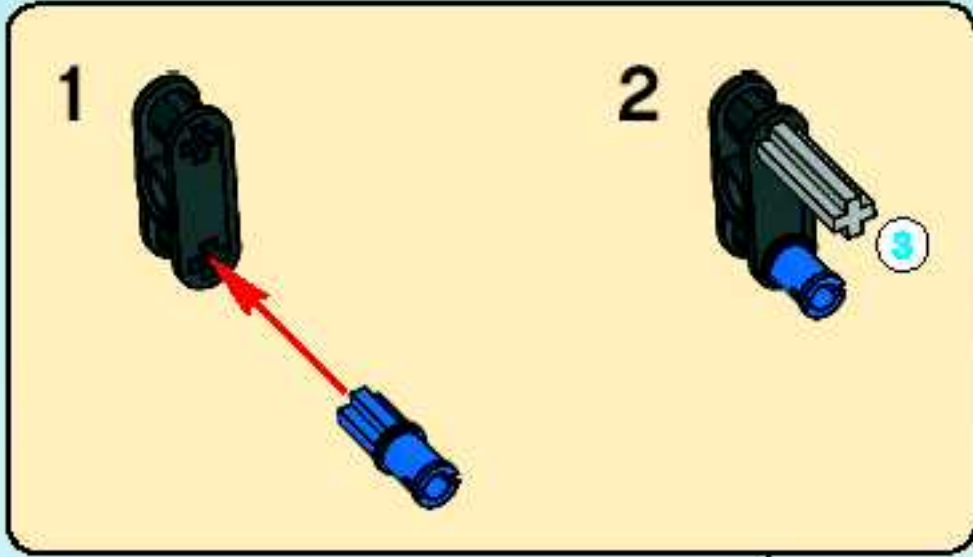



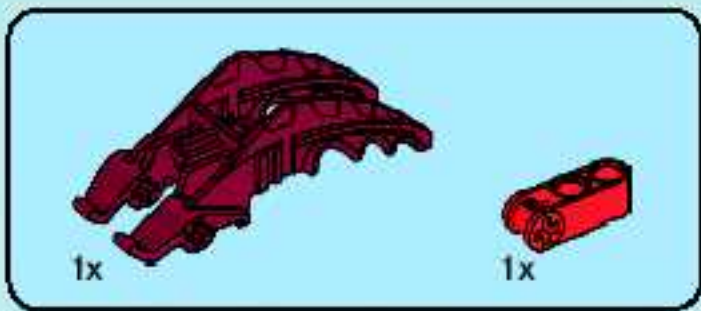

7

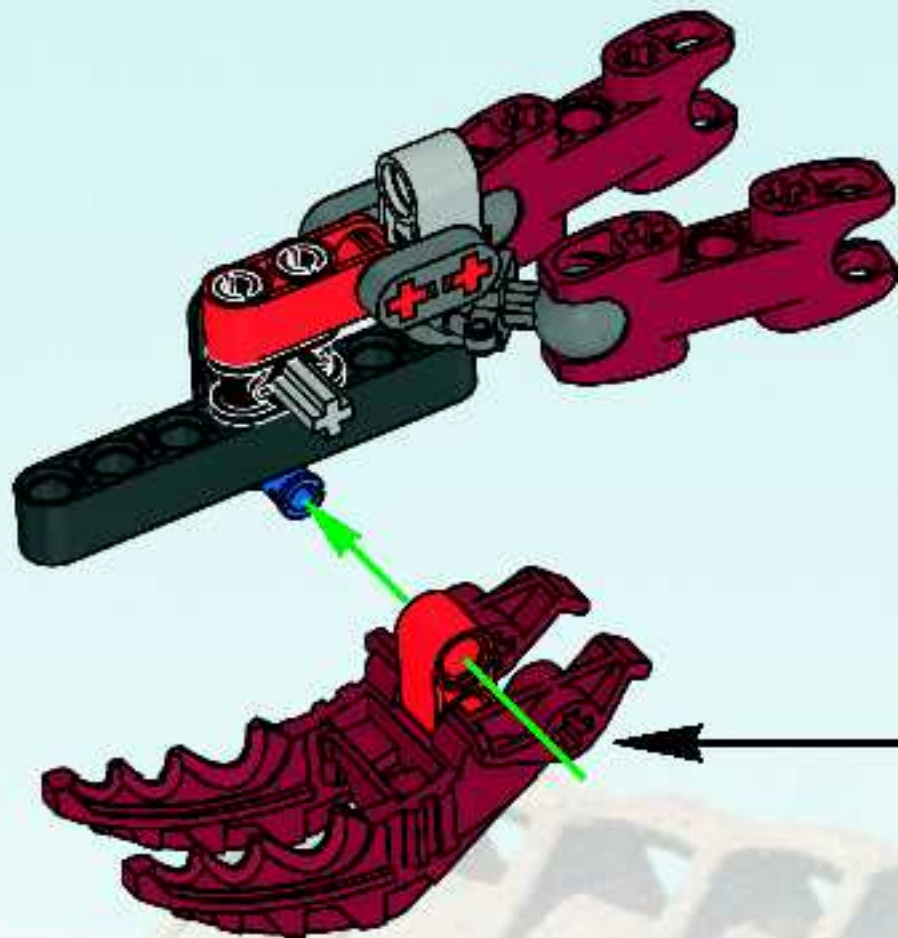
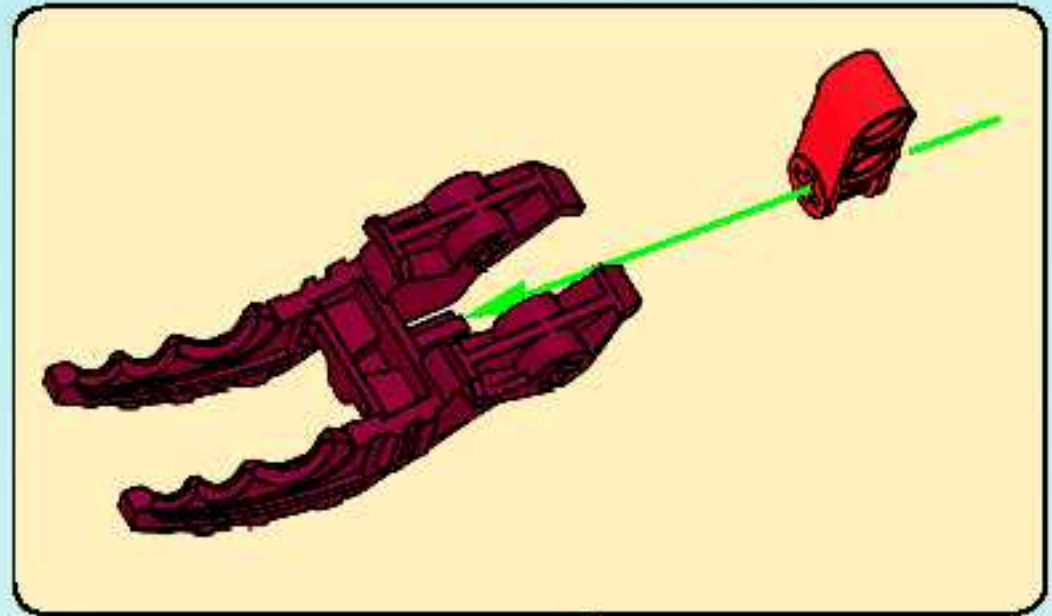



8

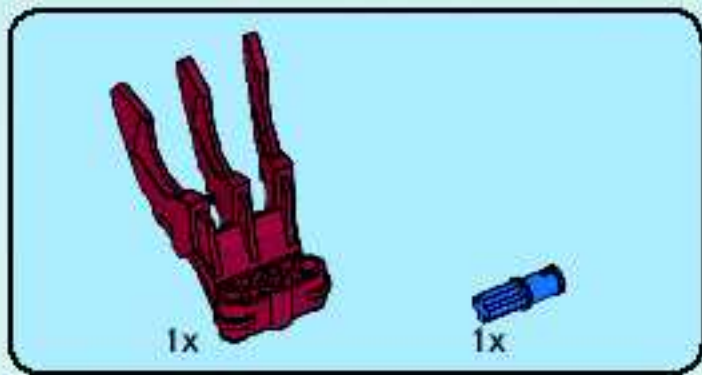
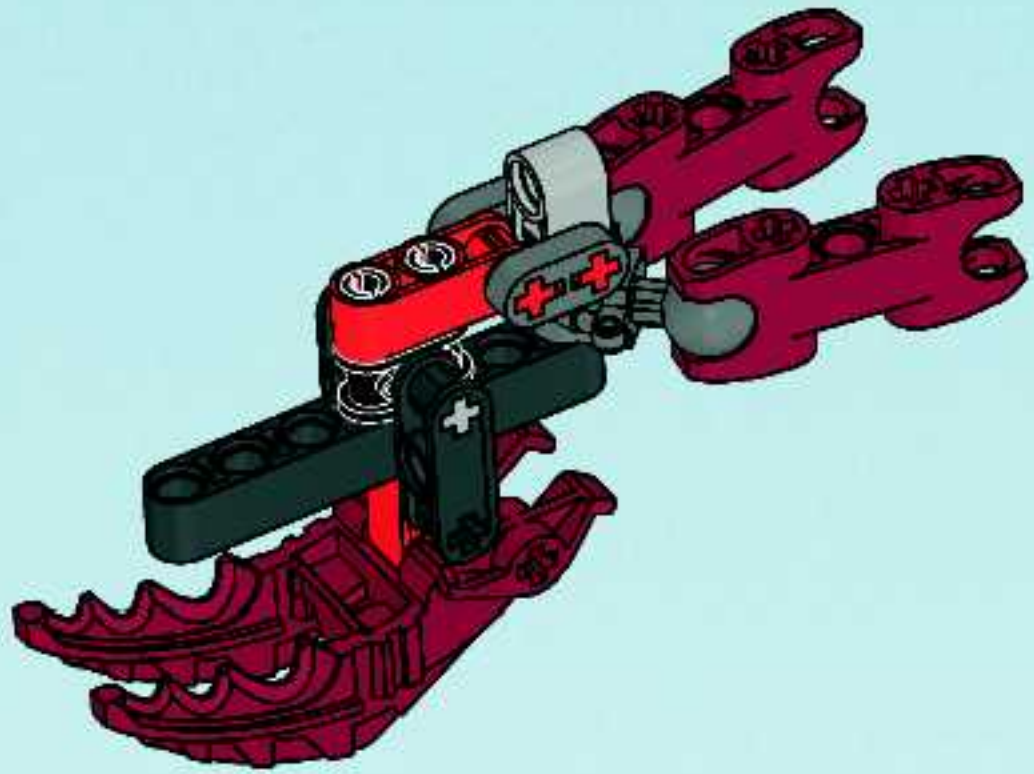

9

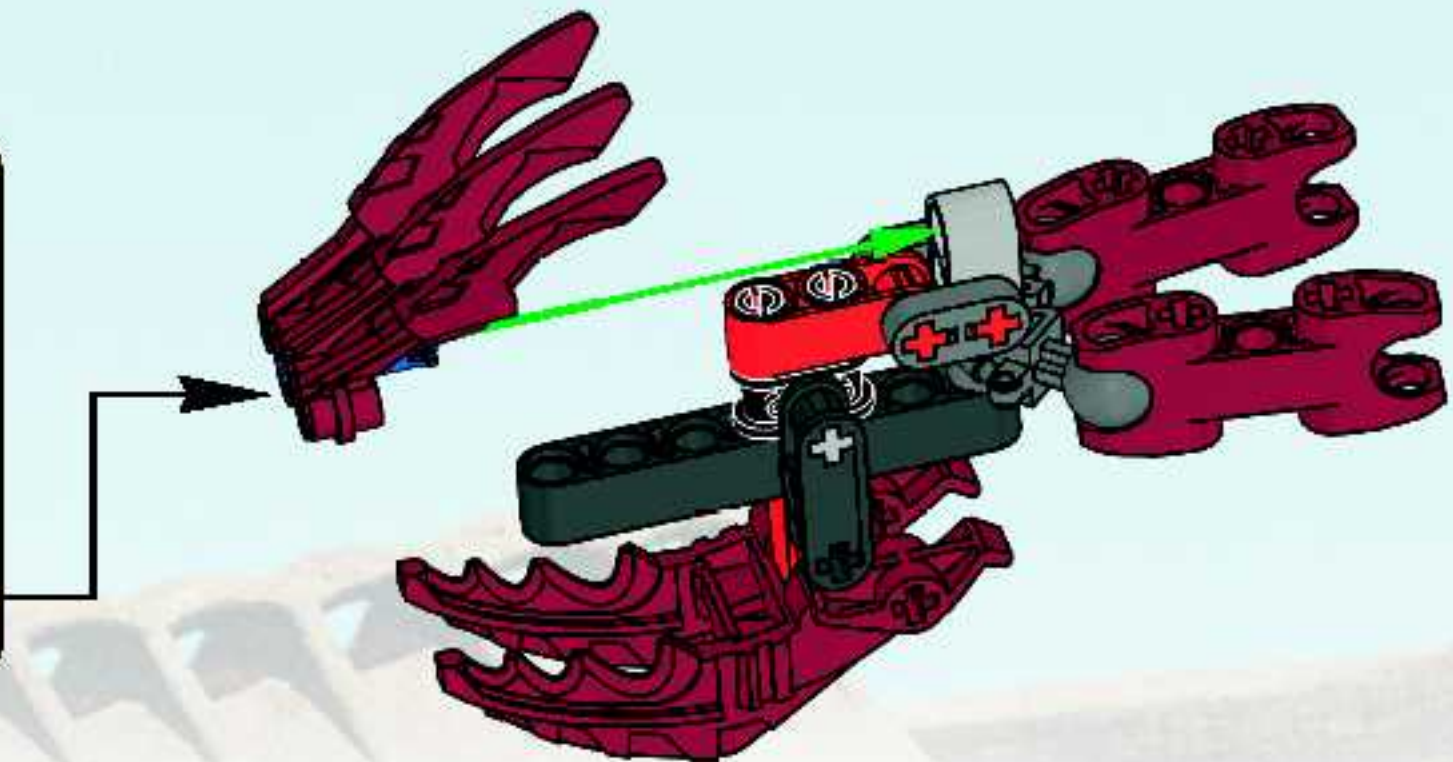
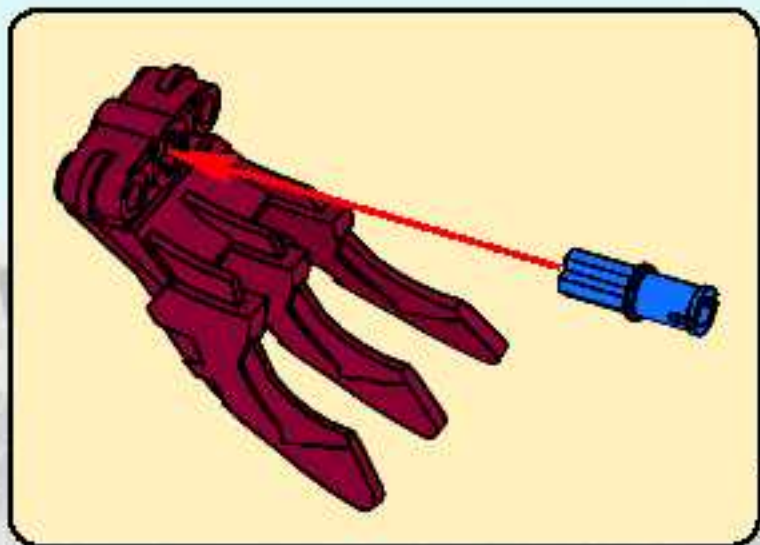



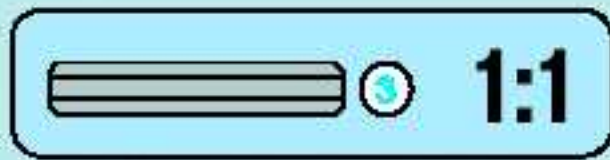
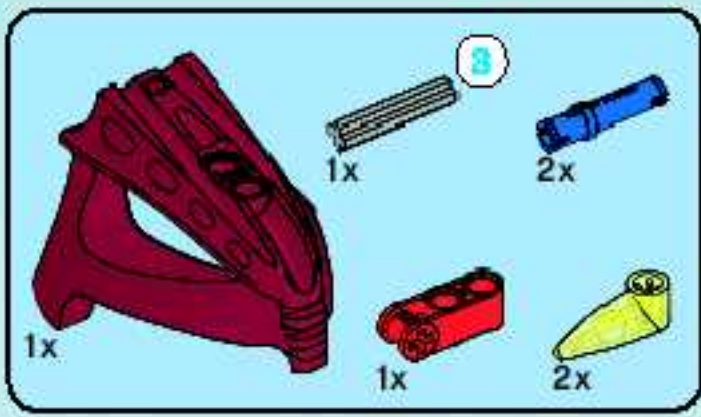

10

1

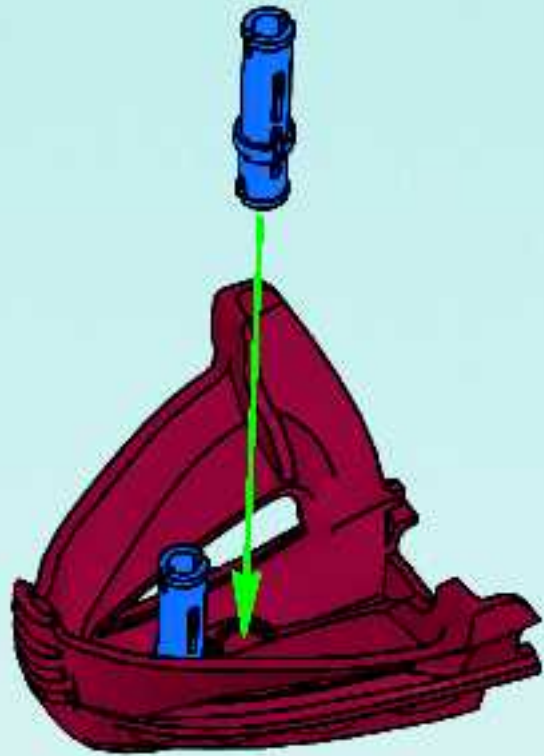

2



3

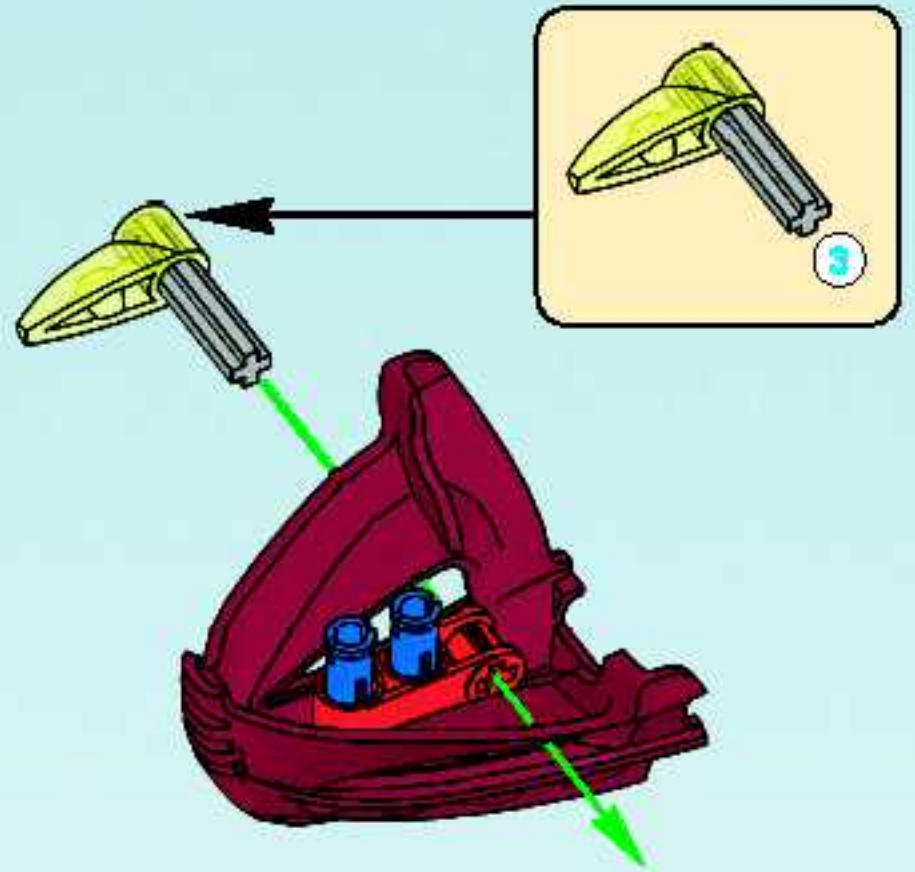

4

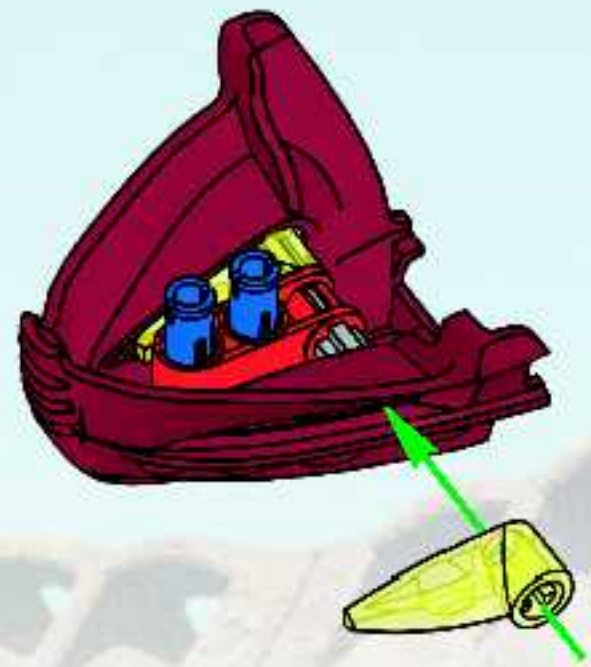

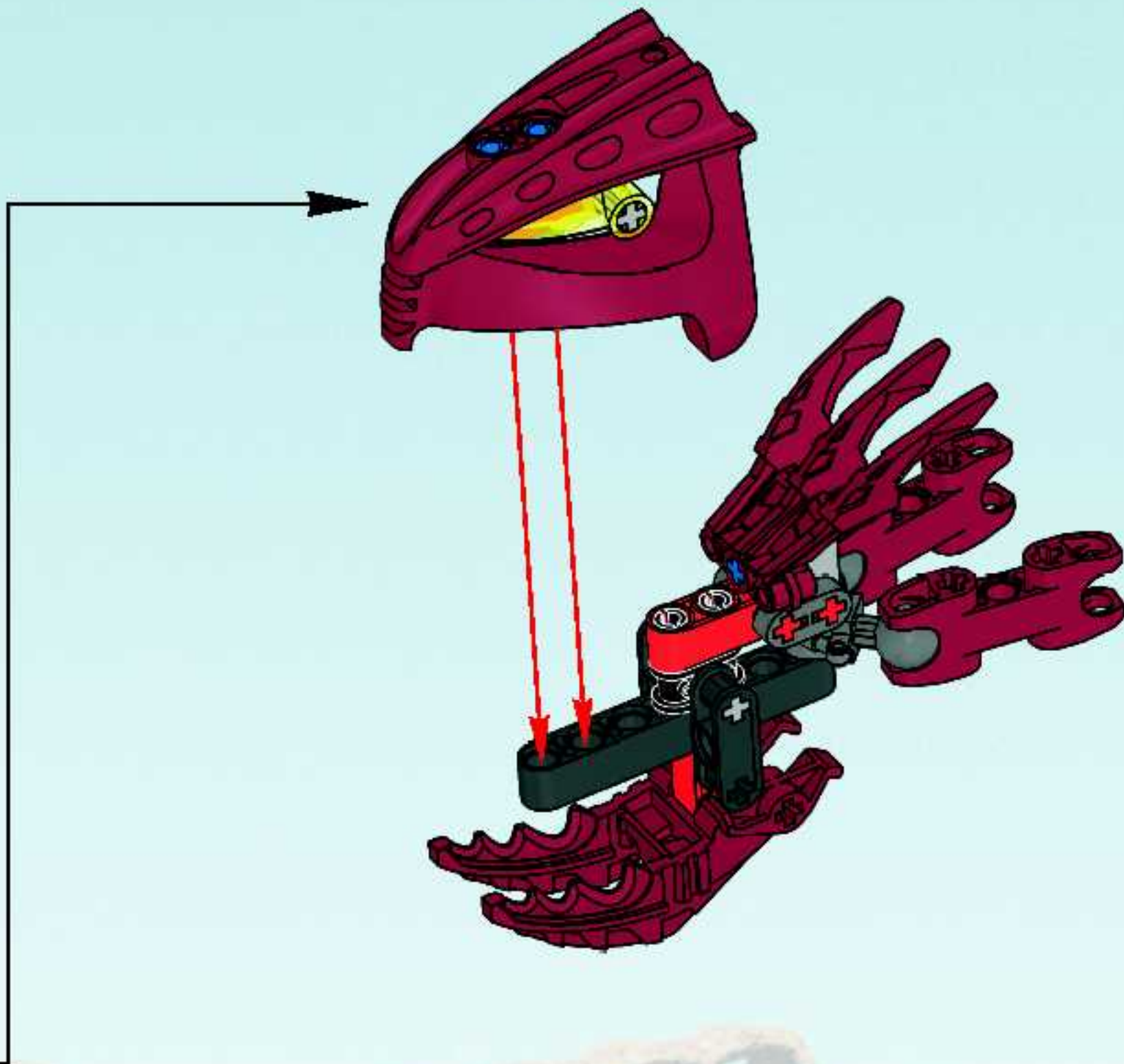



11

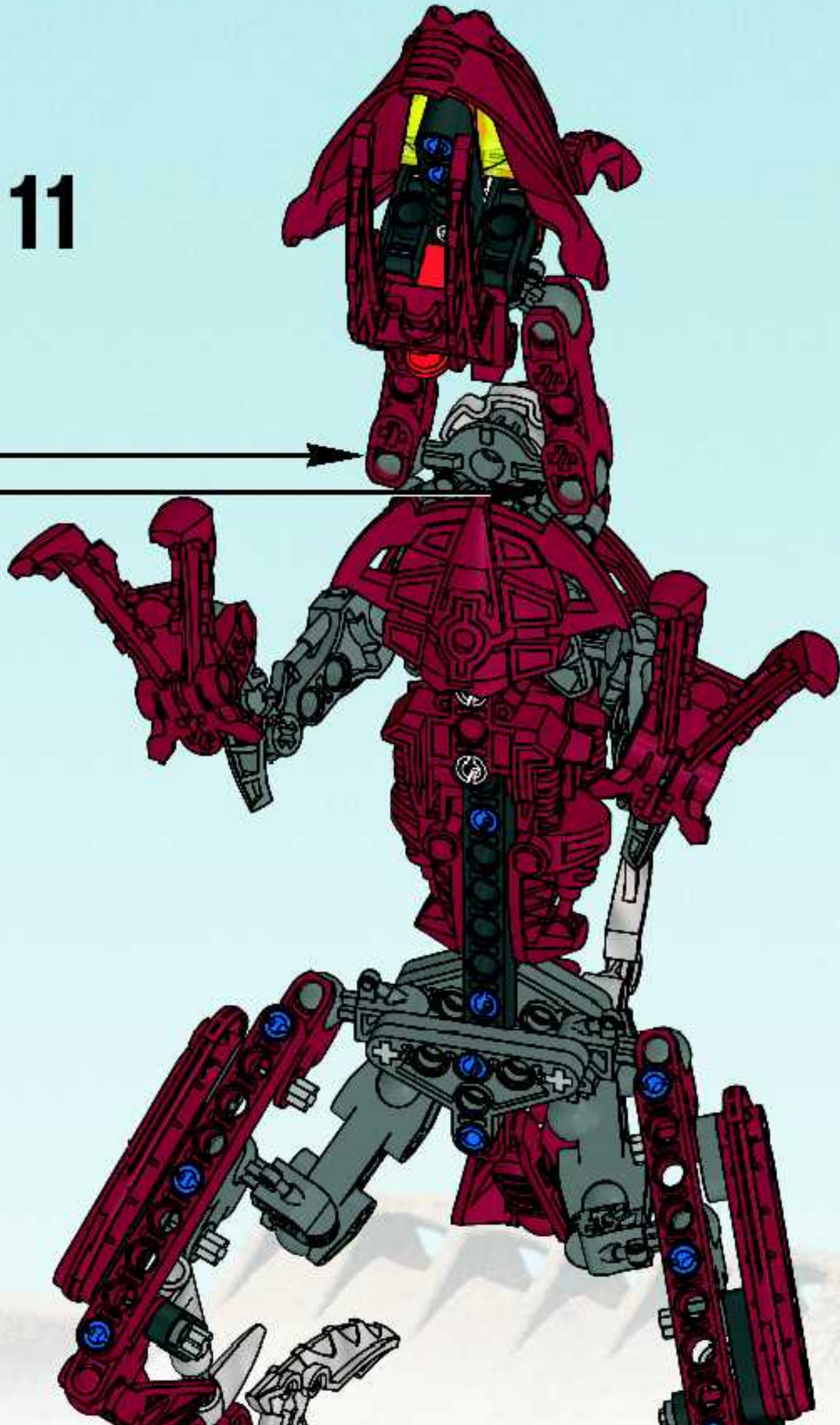



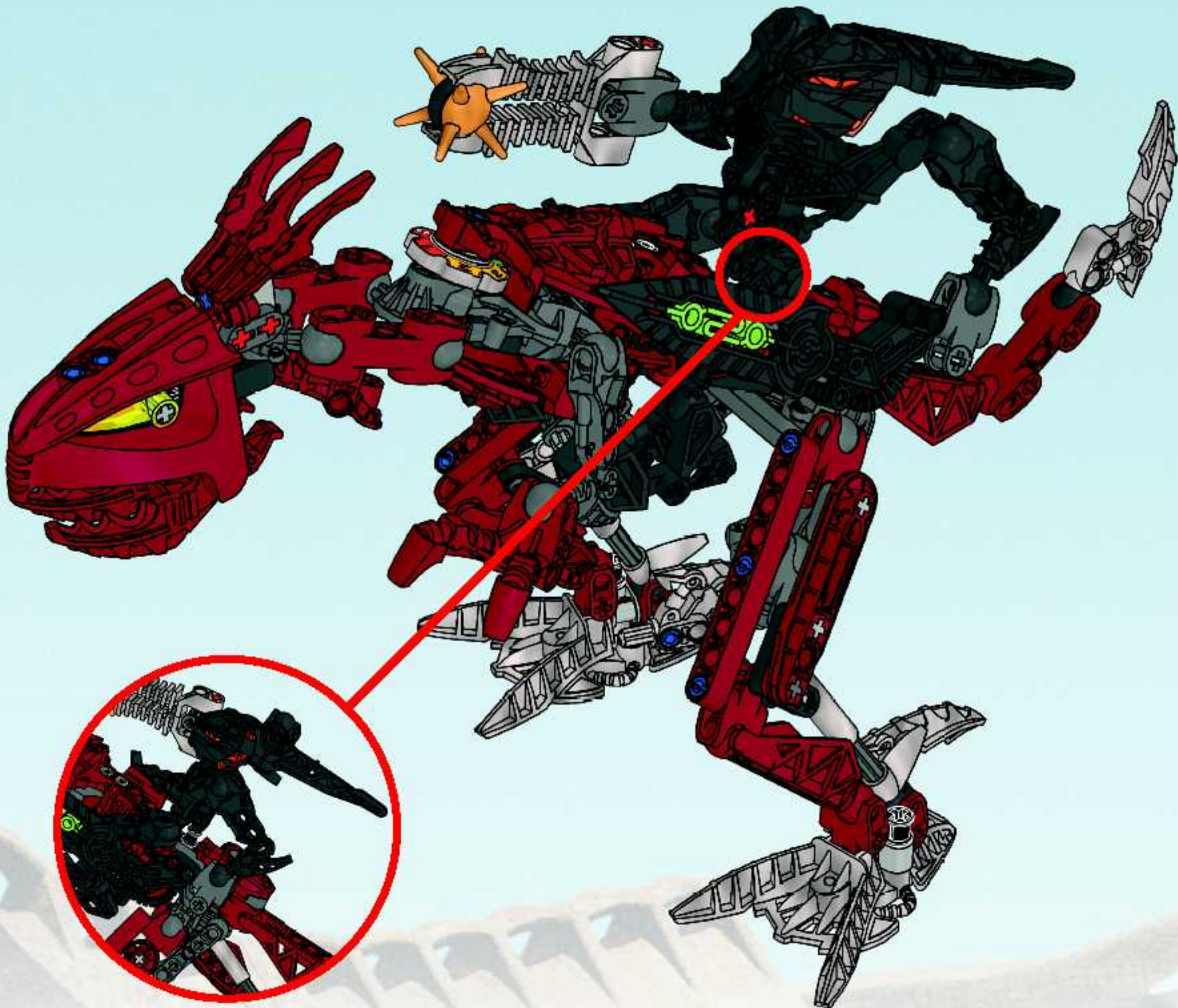





3x  
4539264



9x  
4540569



2x  
4540572



1x  
4540739



2x  
4540567



2x  
4540571



1x  
4539835



1x  
4540566



2x  
4540570



2x  
4539283



3x  
4540568



1x  
4539292



1x  
4539836



6x  
4121715



3x  
4140801



1x  
4119589



4x  
4526578



1x  
4107765



3x  
4121667



3x  
4286267



2x  
4107828



2x  
4112287



2x  
4538946



1x  
4495935



1x  
4520075



1x  
4522933



1x  
4541817



1x  
4537504



2x  
4163577



15x  
4206482



6x  
4514553



10x  
4211815



3x  
4211775

7

13



1x  
4211050



2x  
4211086



2x  
4520068



2x  
4519254



4x  
4519225



2x  
4499858



5x  
4540593



1x  
4542576



4x  
4210980



4x  
4210689



1x  
4516400



5x  
4142865



3x  
4175442



2x  
4177440



1x  
4544529



2x  
4494486



2x  
4546416



2x  
4276534



3x  
4497138



1x  
4546585



1x  
4540702

15

3

9



Customer Service

Kundenservice

Service Consommateurs

Servicio Al Consumidor

www.lego.com/service or dial

: 00800 5346 5555

: 1-800-422-5346



8983

8981

8982

8976

8975

8990

8977

8980



8974



8979

8973

8978



8972



8991

For more rules on advanced multi-figure game play - check out

Pour plus d'information concernant les règles des jeux de niveau avancé avec plusieurs figurines, visitez

Para más información sobre instrucciones de juego avanzado con varias figuras, consulta

www.BIONICLE.com



# GLATORIAN BIONICLE

FOR VICTORY - FOR GLORY - FOR POWER



LEGO





8978



8979



8980



8981



8983



8982





8972



8973



8974

[www.BIONICLE.com](http://www.BIONICLE.com)



8975



8977



8976





WWW.BIONICLE.COM

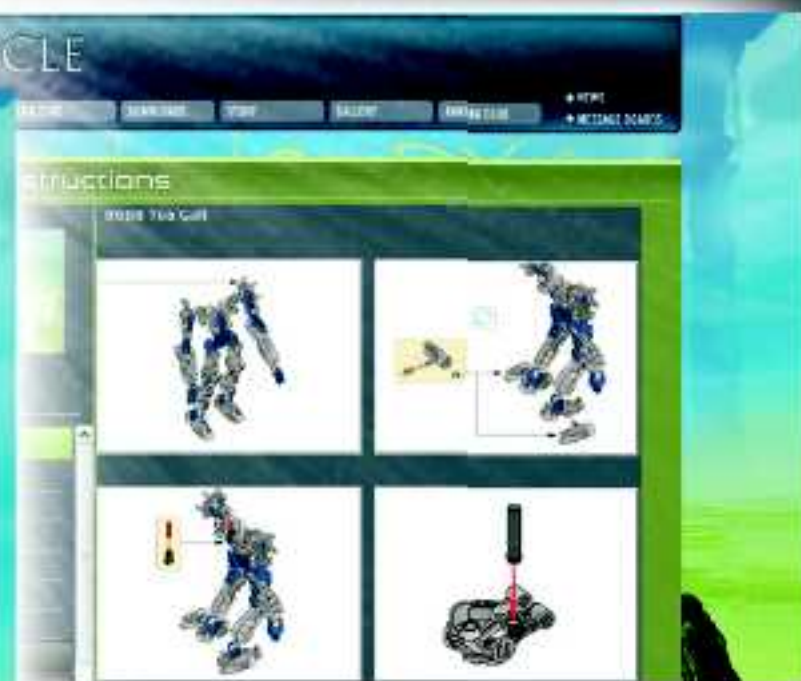



[www.nielsen.com/LEGO](http://www.nielsen.com/LEGO)



## WIN LEGO® PRODUCTS

Fill out a survey and you might WIN a cool LEGO product  
NO PURCHASE NECESSARY

Open to all residents where not prohibited

Go to [www.nielsen.com/LEGO](http://www.nielsen.com/LEGO) to fill out a survey for a chance to win a LEGO product.

## WIN LEGO® PRODUCTEN

Vul een enquêteformulier in en maak kans op een cool LEGO® product!

Kopen niet nodig

Iedereen uit landen waar geen enquêteverbod geldt mag deelnemen.

Ga naar [www.nielsen.com/LEGO](http://www.nielsen.com/LEGO), vul een enquêteformulier in en maak kans op een LEGO product.

## GEWINNE LEGO® PRODUKTE

Nimm an der Umfrage teil und GEWINNE ein tolles LEGO® Produkt!

Die Teilnahme am Gewinnspiel führt zu keinerlei Kaufverpflichtungen

Teilnahme in allen nicht ausgeschlossenen Ländern möglich

Wir verlosen unter allen Teilnehmern der Umfrage auf [www.nielsen.com/LEGO](http://www.nielsen.com/LEGO) LEGO Produkte.

## GAGNE DES PRODUITS LEGO®

Réponds à un questionnaire et tu pourrais GAGNER un produit LEGO® très cool !

Aucune obligation d'achat

Ouvert à tous les résidents des pays autorisés.

Visite [www.nielsen.com/LEGO](http://www.nielsen.com/LEGO) pour répondre à un questionnaire et avoir une chance de gagner un produit LEGO.

## レゴ®製品を「当てよう」

アンケートに記入して、かっこいいレゴ®製品を当てよう！

お買い上げの必要はありません。

禁止されていない限り、すべての皆様にご利用いただけます。

[www.nielsen.com/LEGO](http://www.nielsen.com/LEGO)にアクセスして、アンケートにご記入ください。当選者にはレゴ®製品を差し上げます。





FREE! GRATIS! GRATUIT!



club MAGAZINE™

www.LEGOclub.com



00800 5346 5555\*

1-866-534-6258 • 1-877-518-5346

US & Canada only

Canada seulement

VISIT THE WORLD'S BIGGEST LEGO® SHOP!

[www.LEGOshop.com](http://www.LEGOshop.com)



[www.LEGO.com](http://www.LEGO.com)

\* Free phone, mobile charges may apply. \* Numéro sans frais. Des frais peuvent s'appliquer avec les téléphones cellulaires. \* Gebührerfrei, Kosten für Anrufe aus Mobilfunknetzen können anfallen. \* Gratis telefonnummer vanaf vaste lijn. \* Débit est gratuit au moment de l'appeler. \* Det är gratis, när du ringer från fast telefon. \* Det är gratis, när du ringer från en fast telefon.