

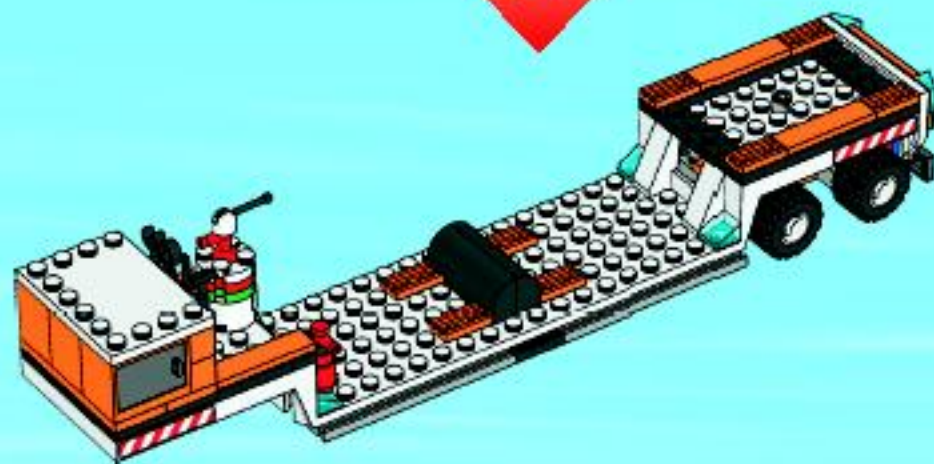

CITY

7686

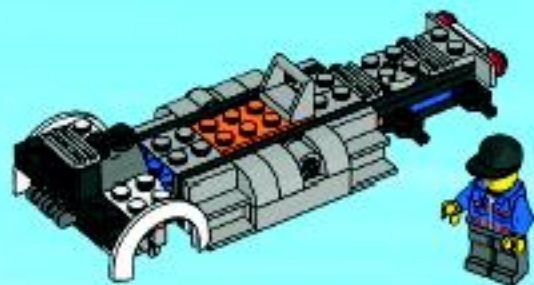



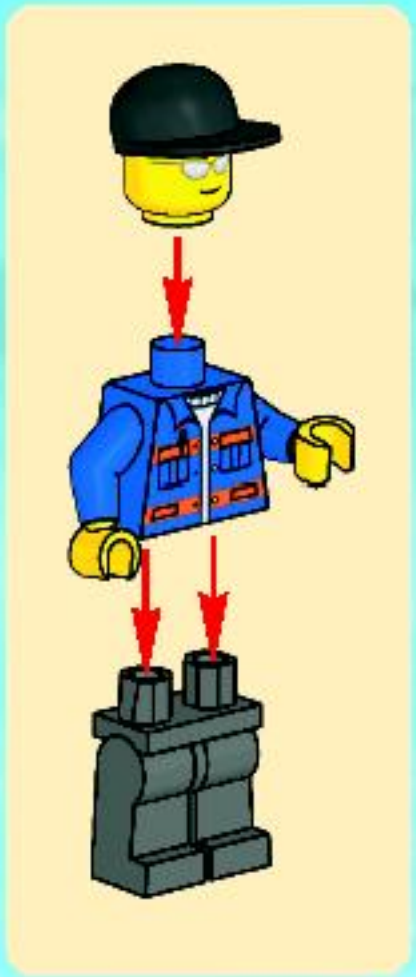
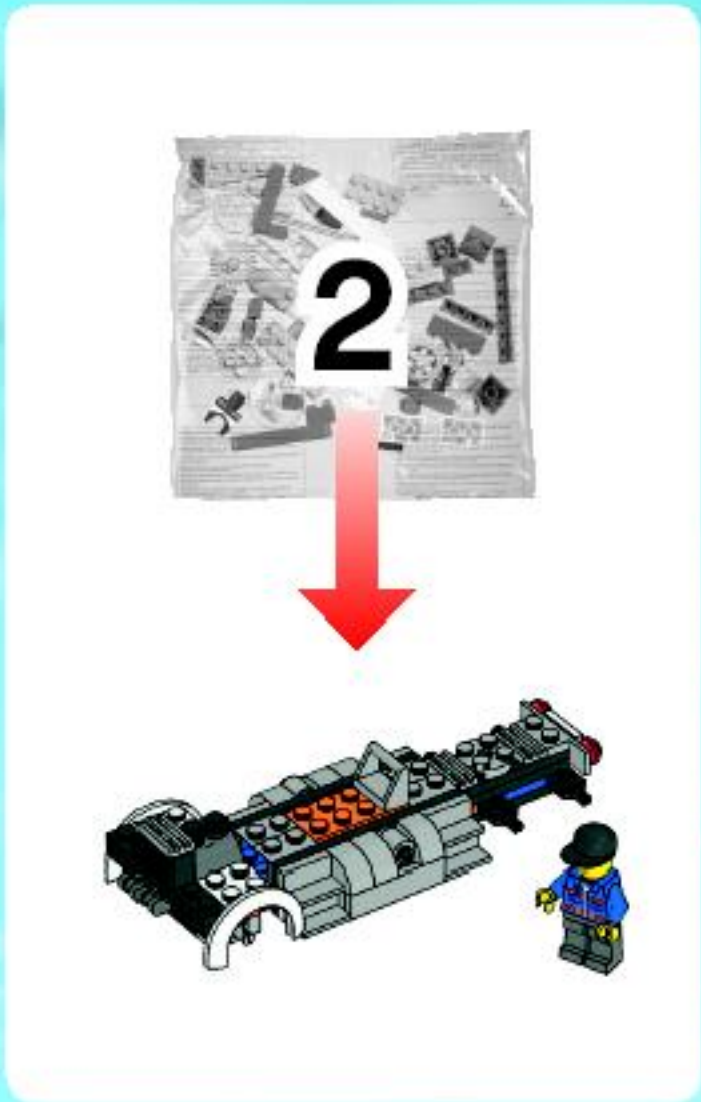

1

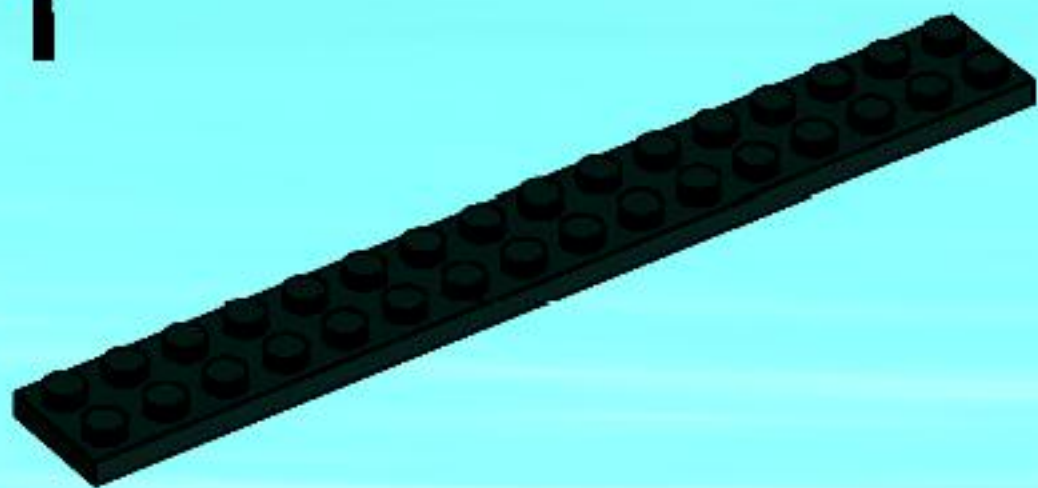

2

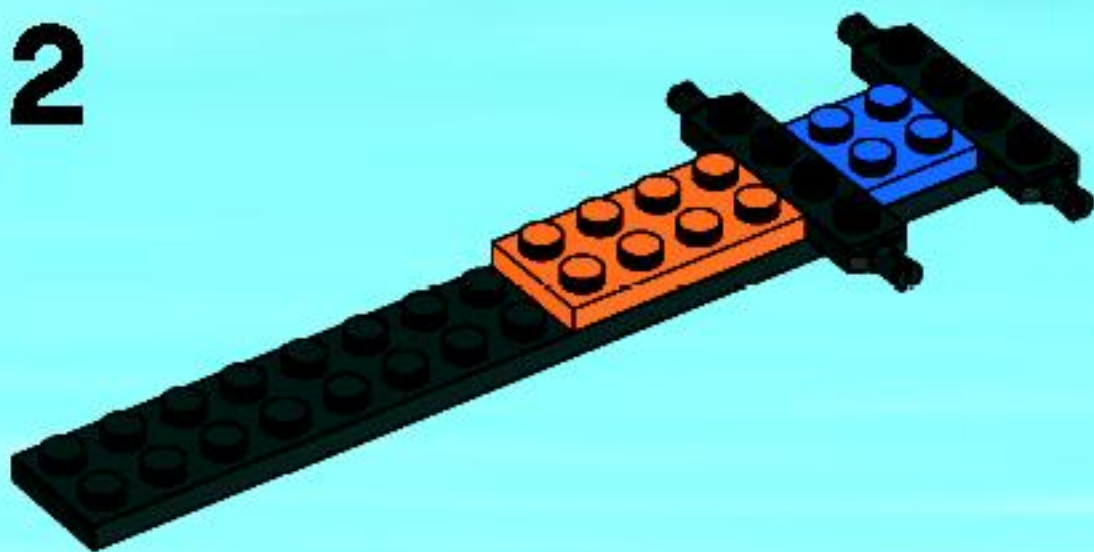

3

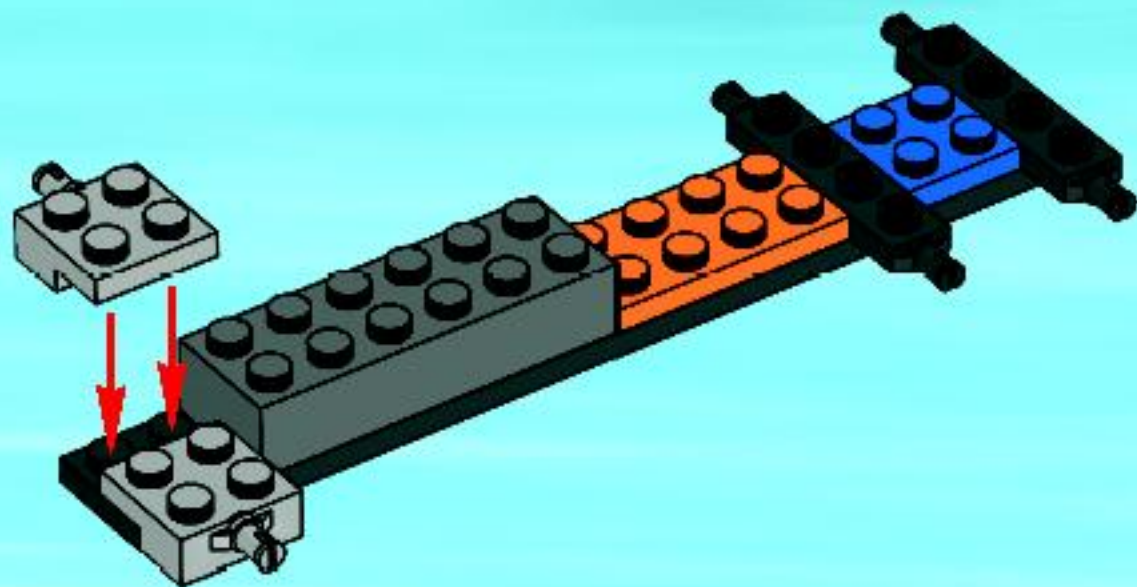

4

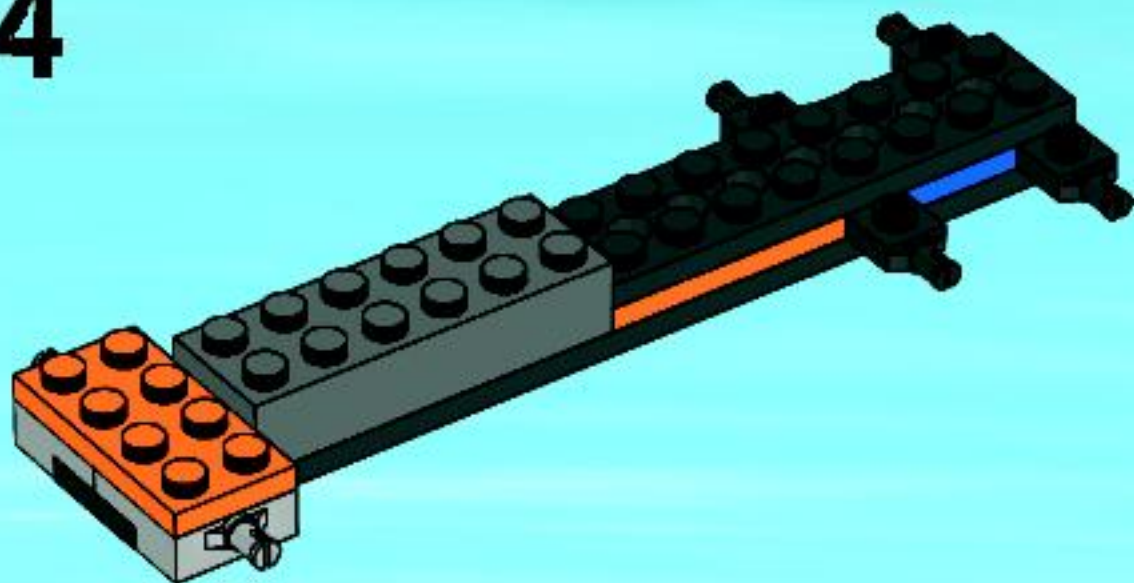

5

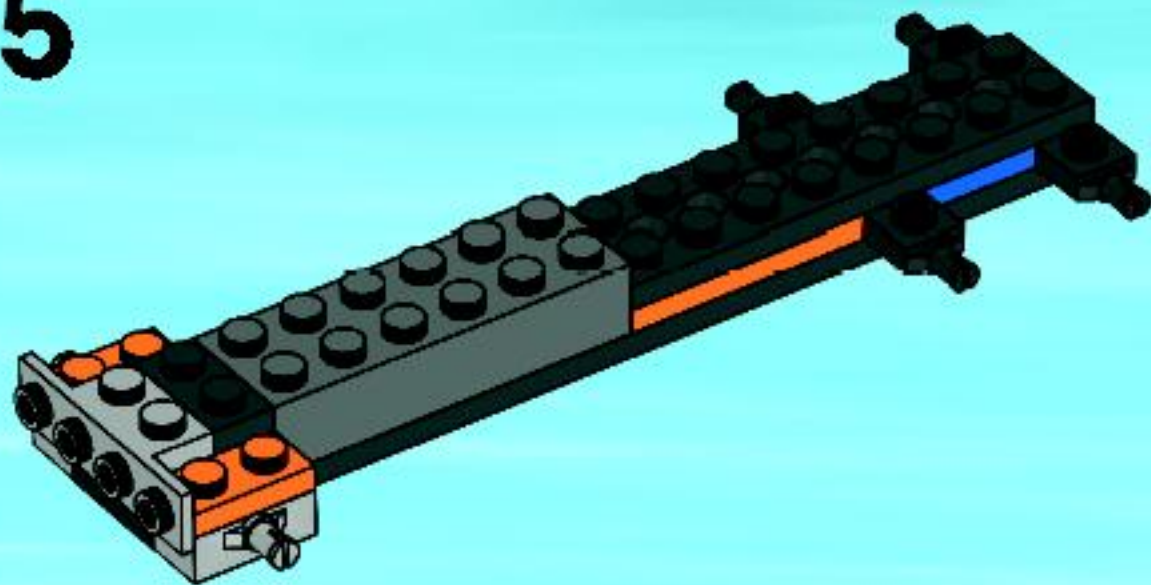

6

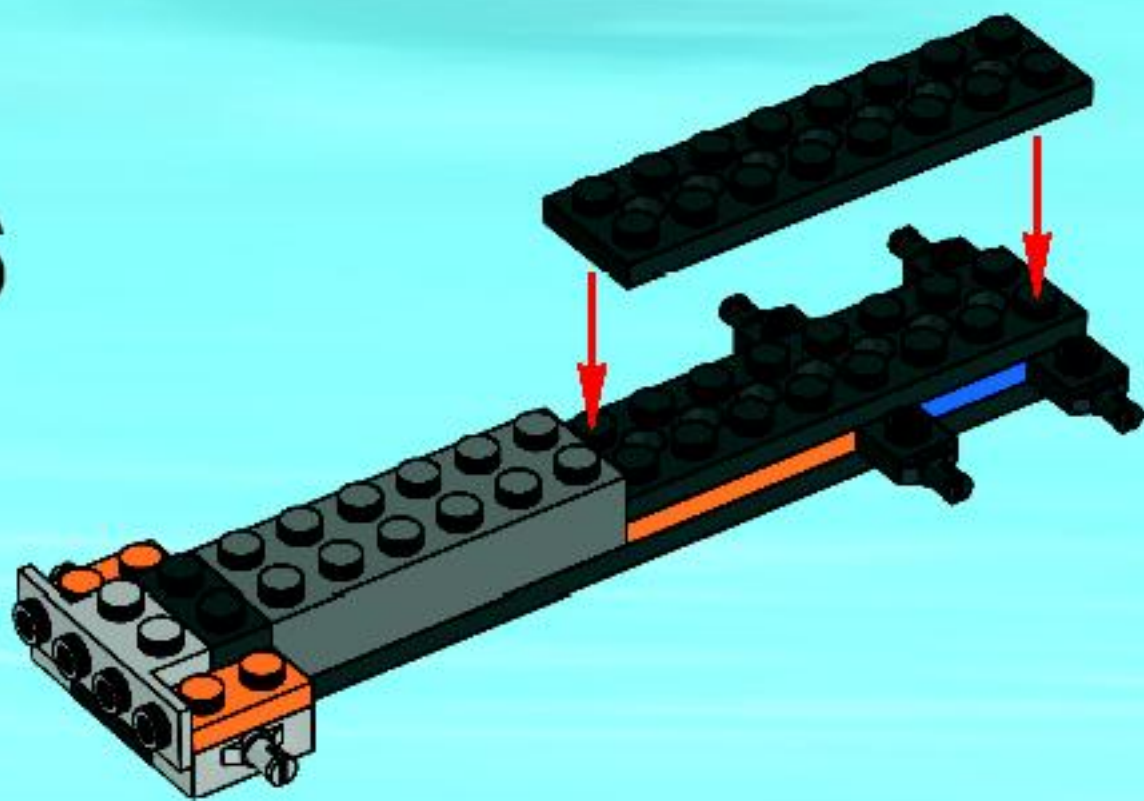

1

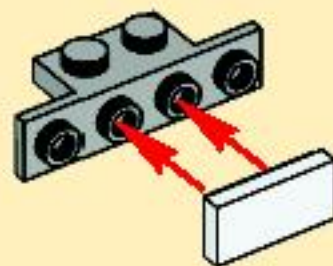

2



7

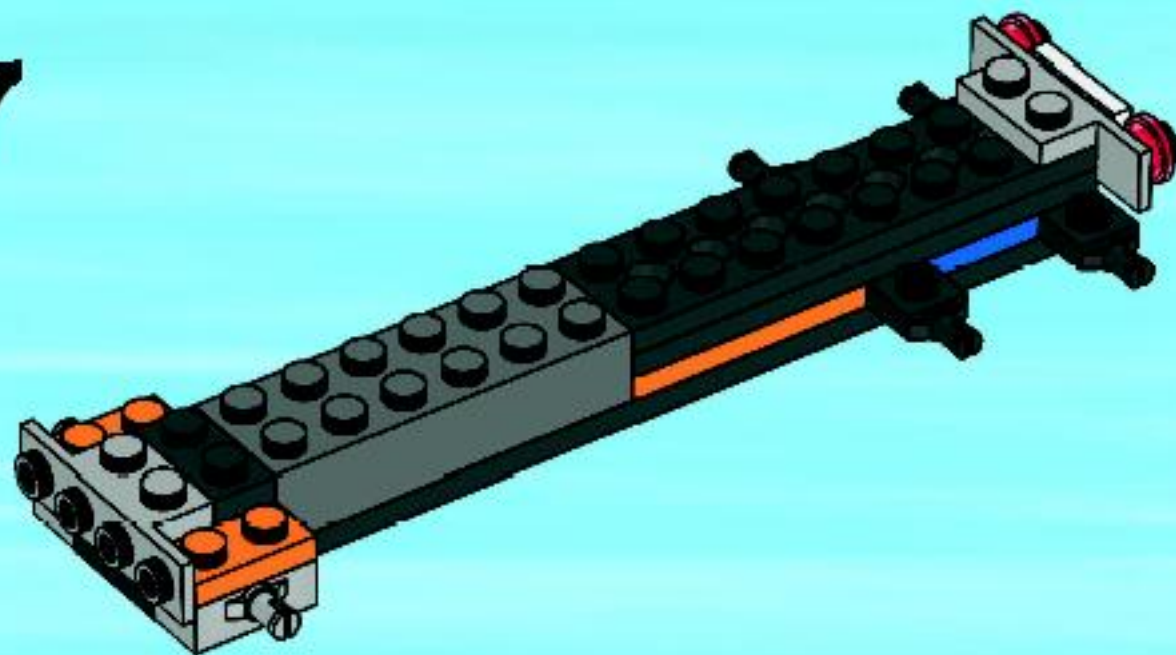

8

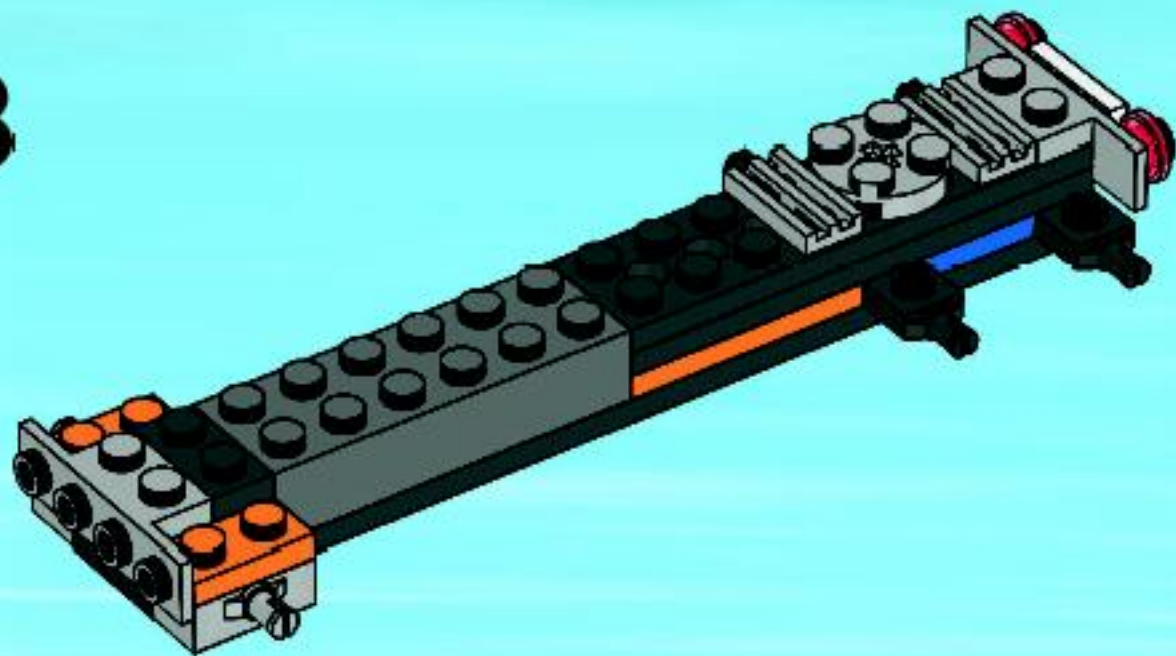

9

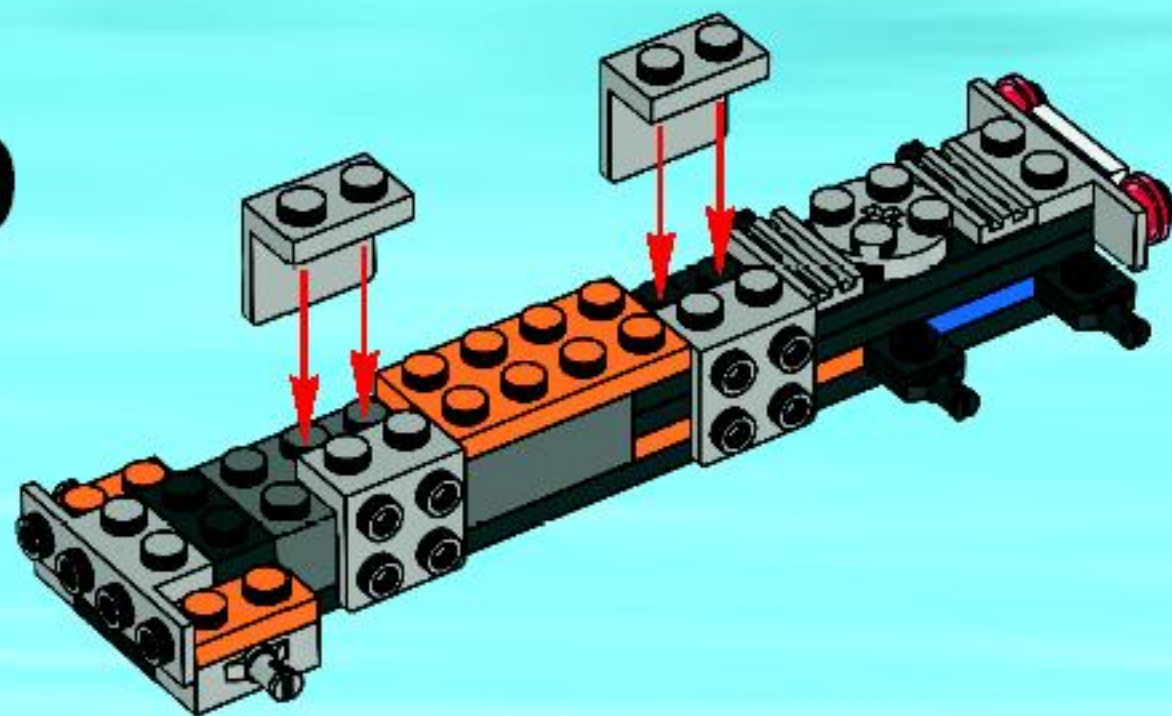

10

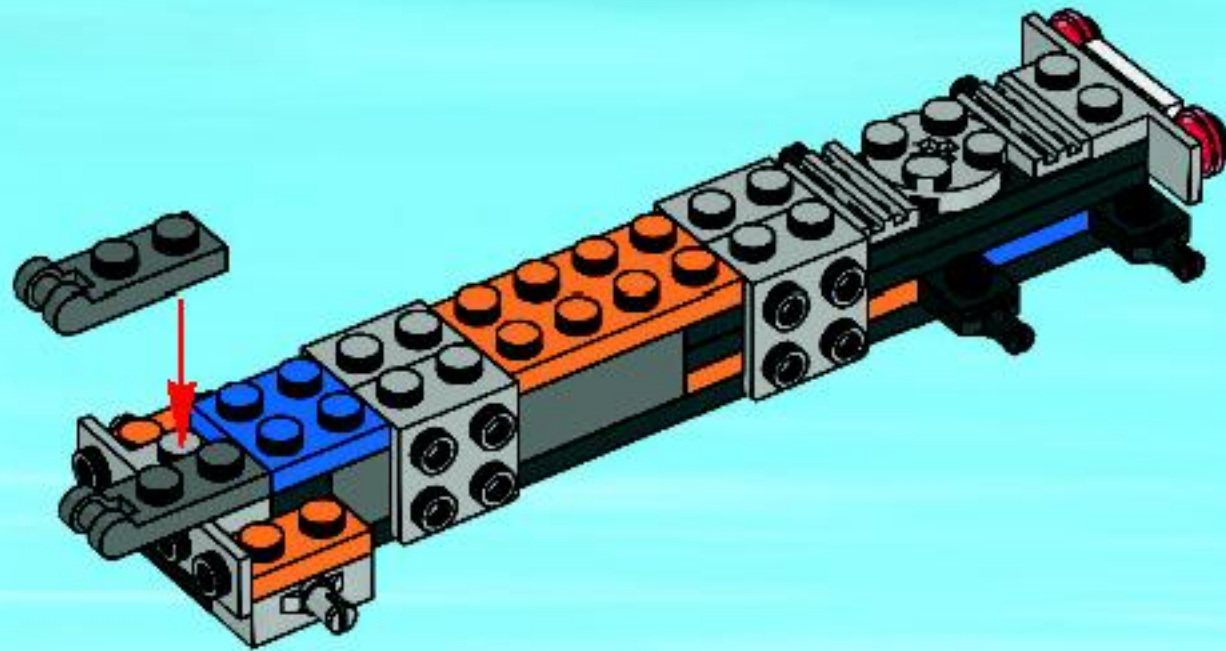

11

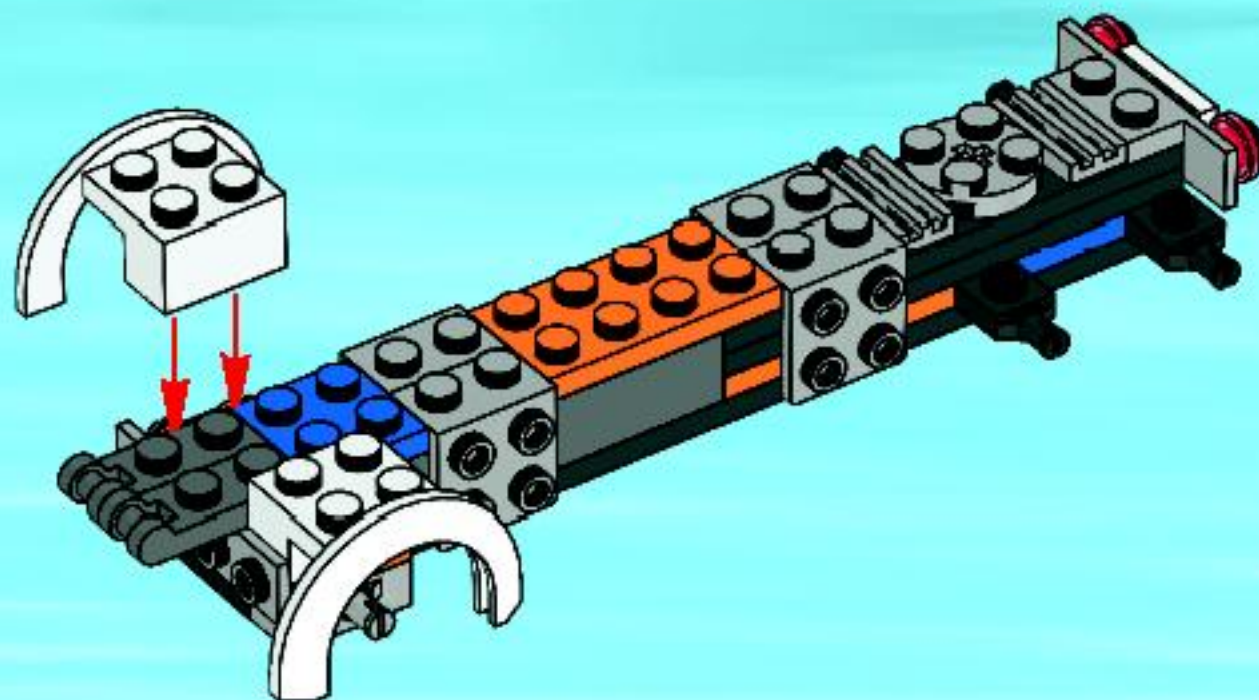

12

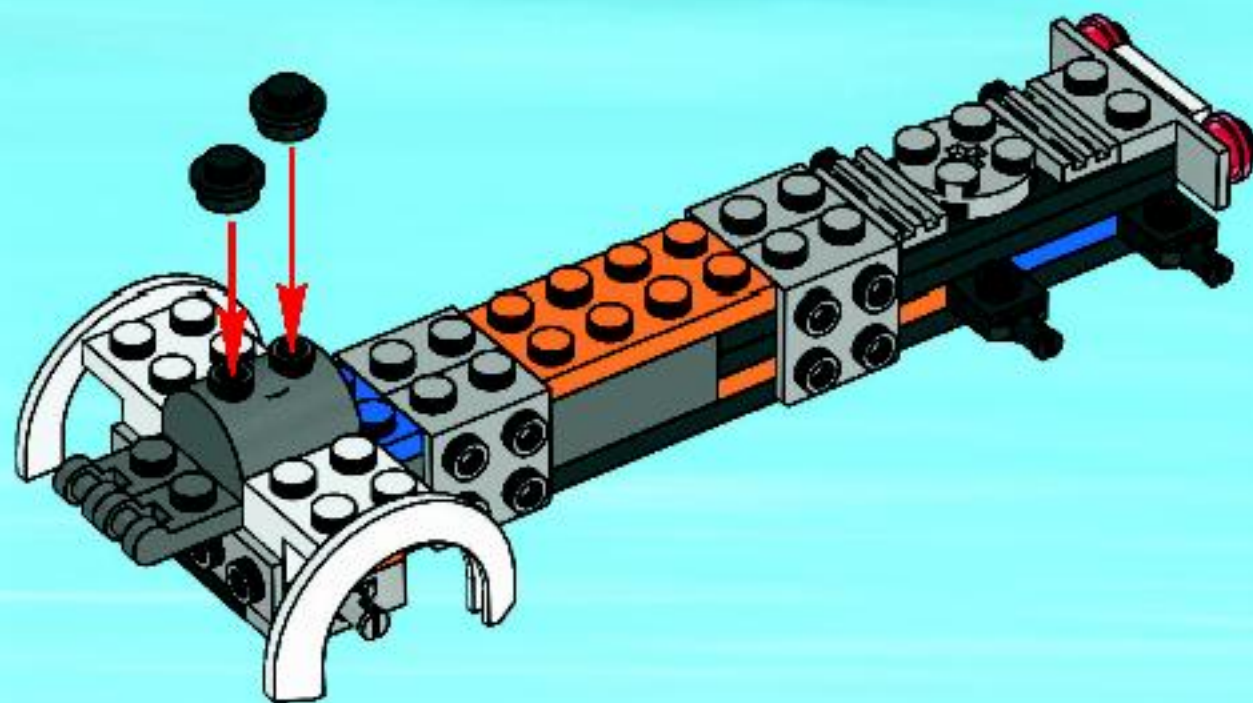

1

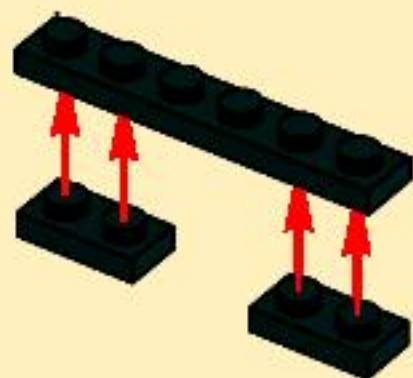

2

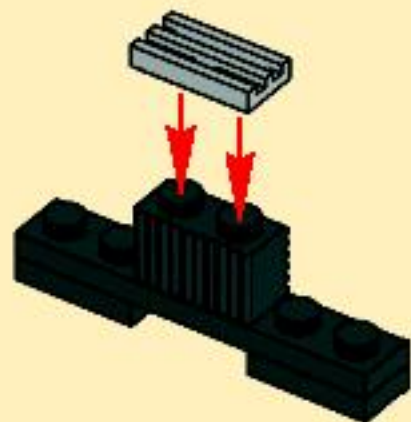

13

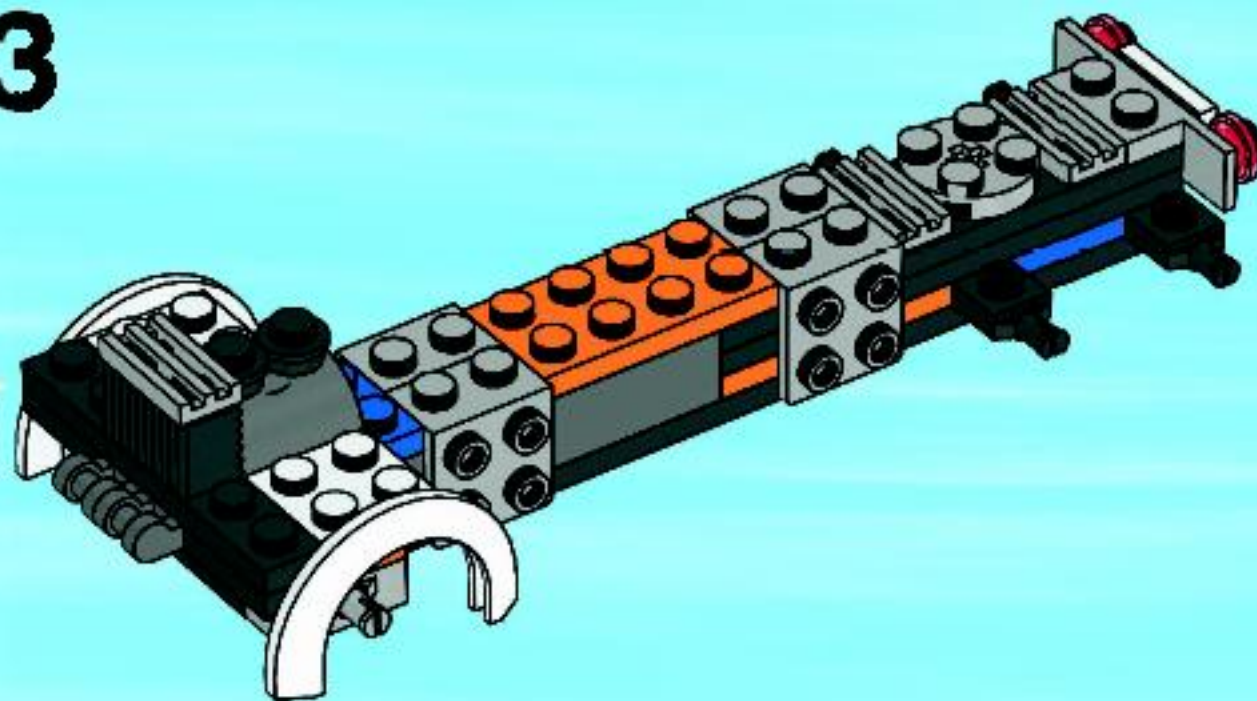



2x

1

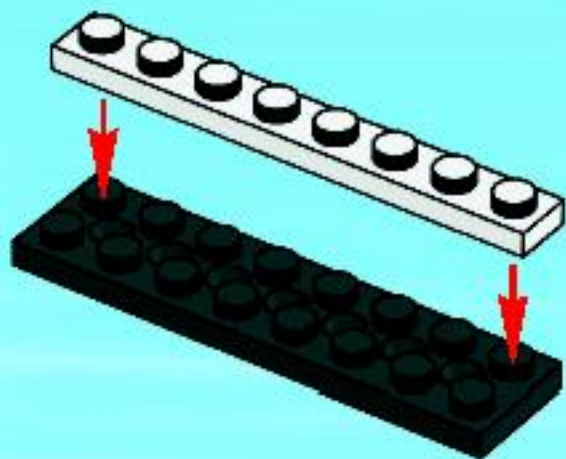

2

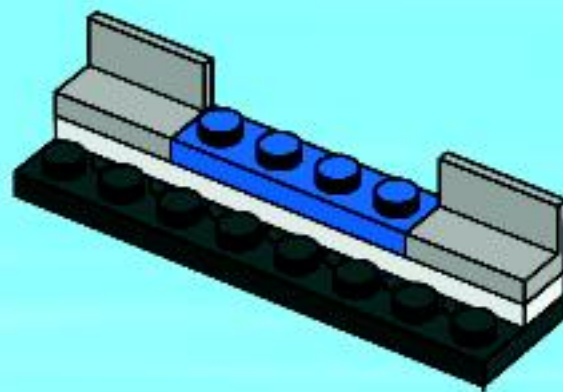

3

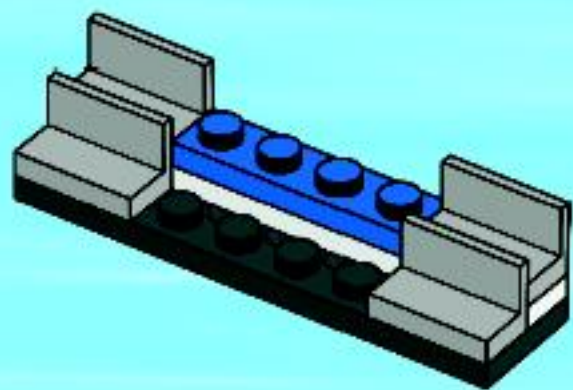

4

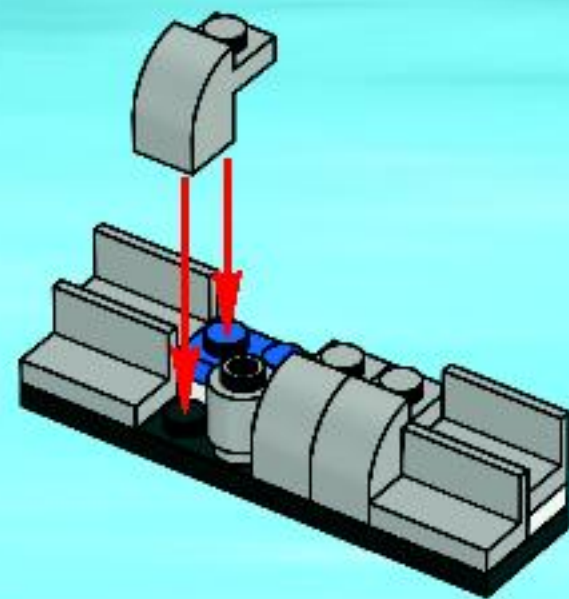

5

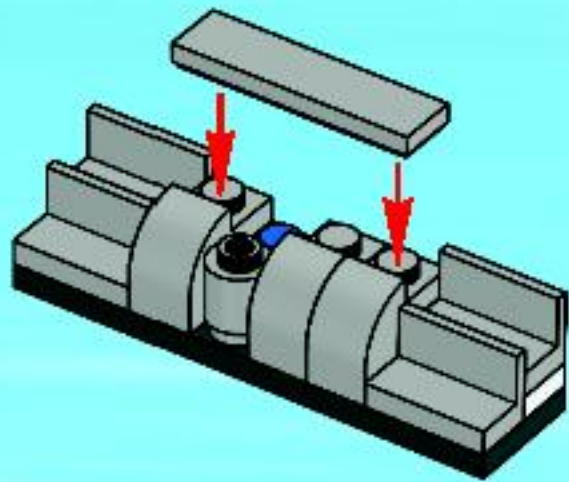

2x

14

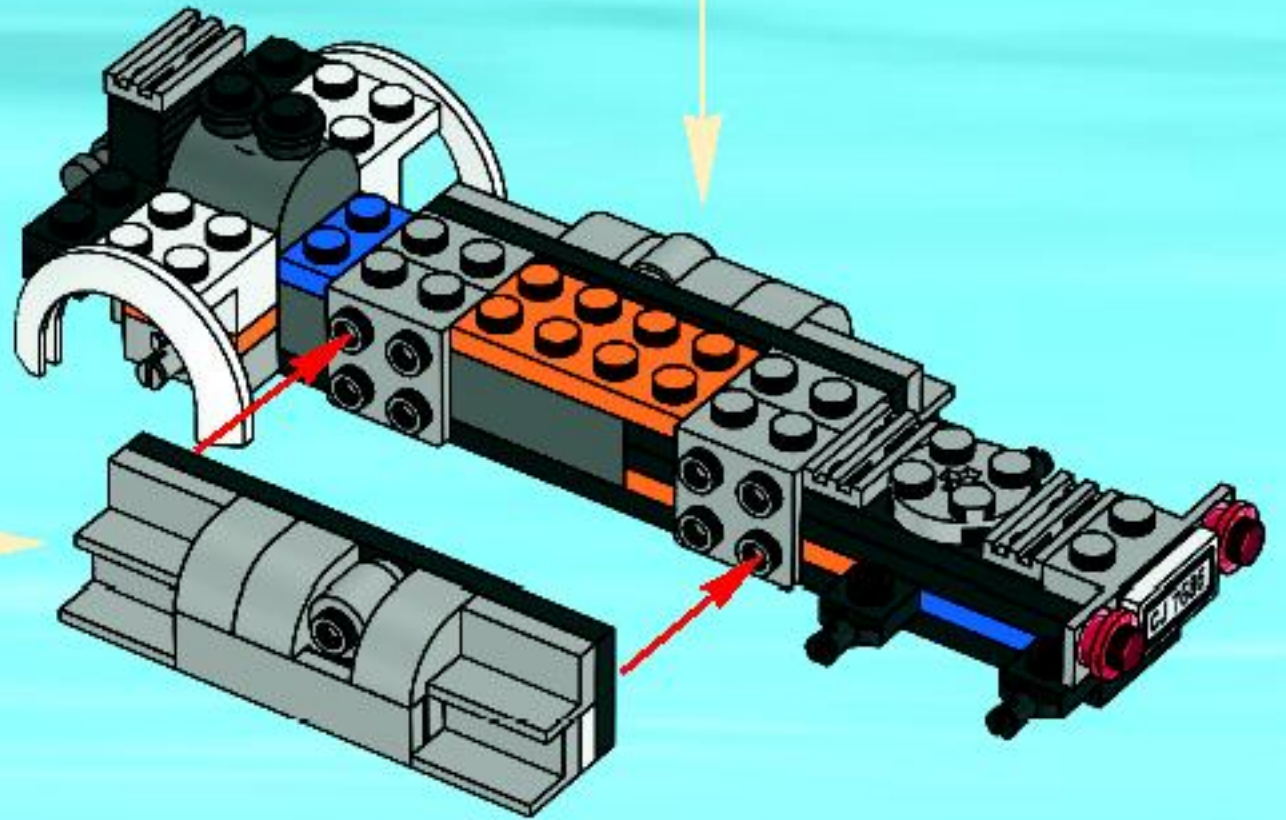

15

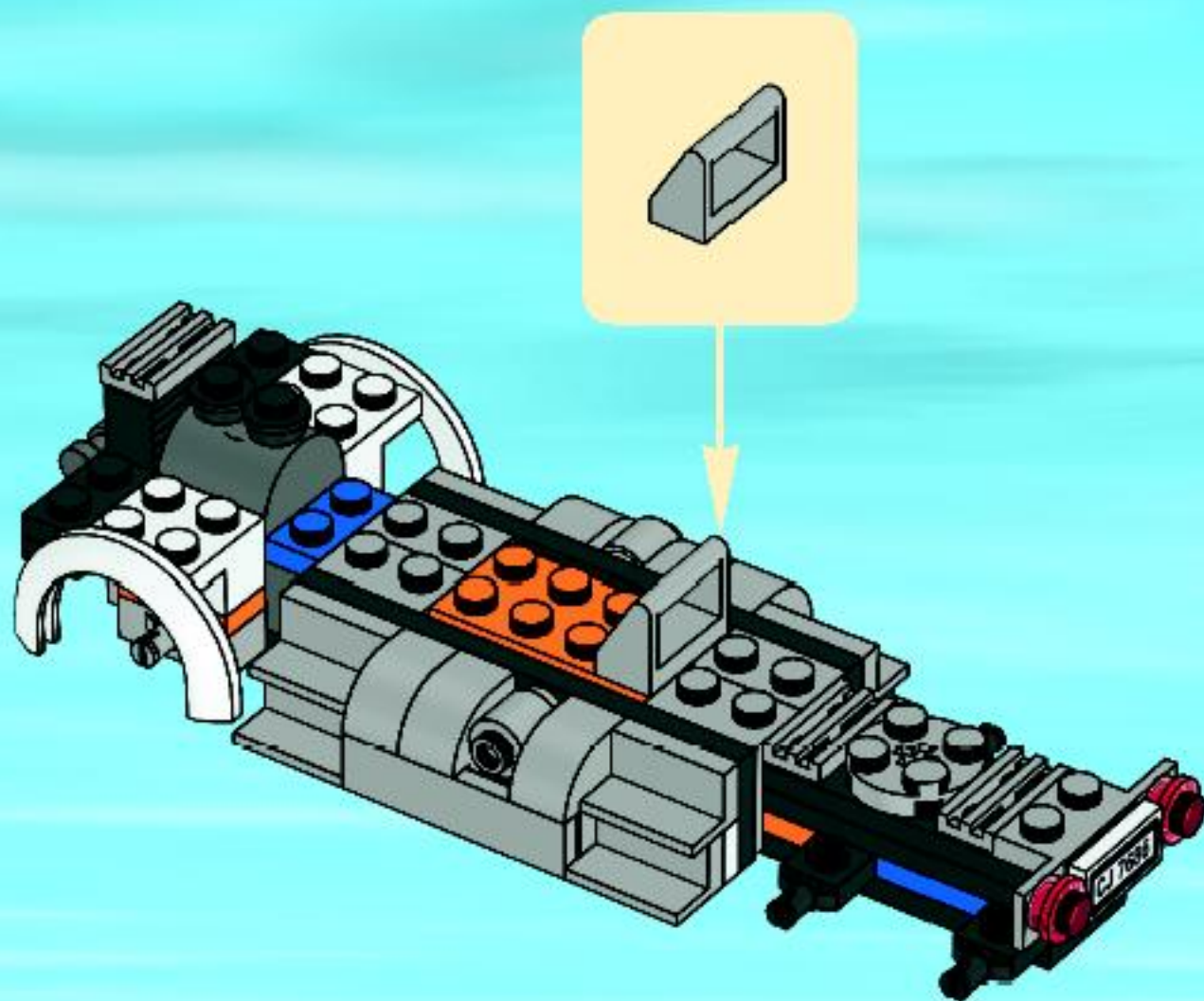

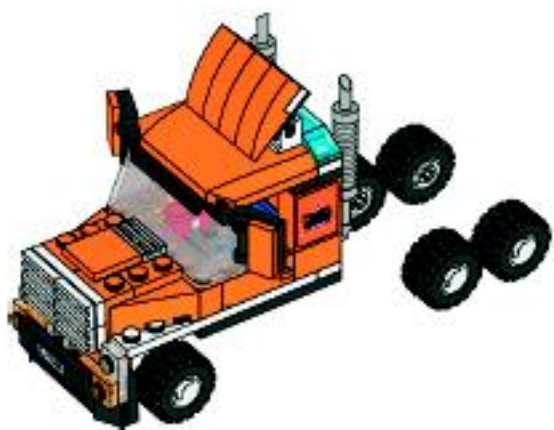

1

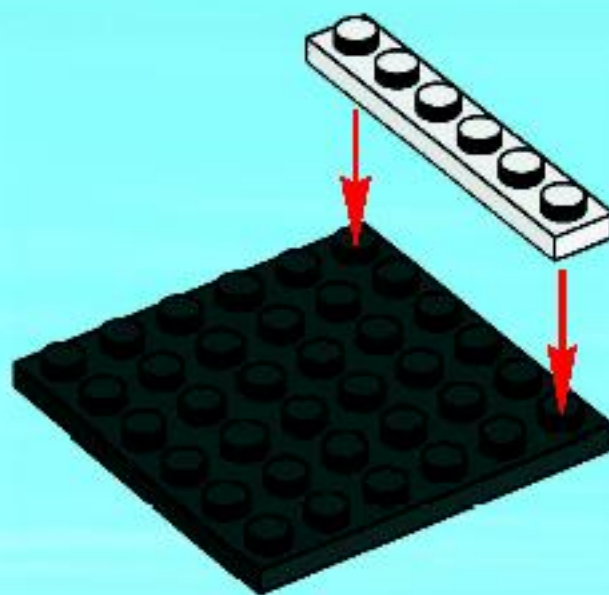

2

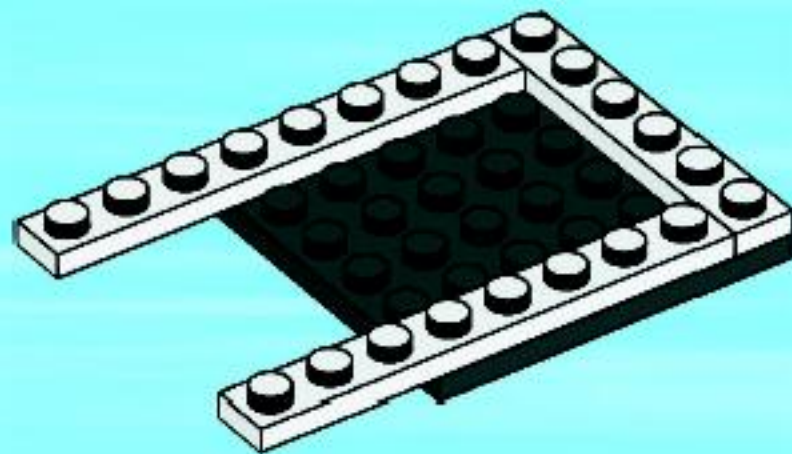

3

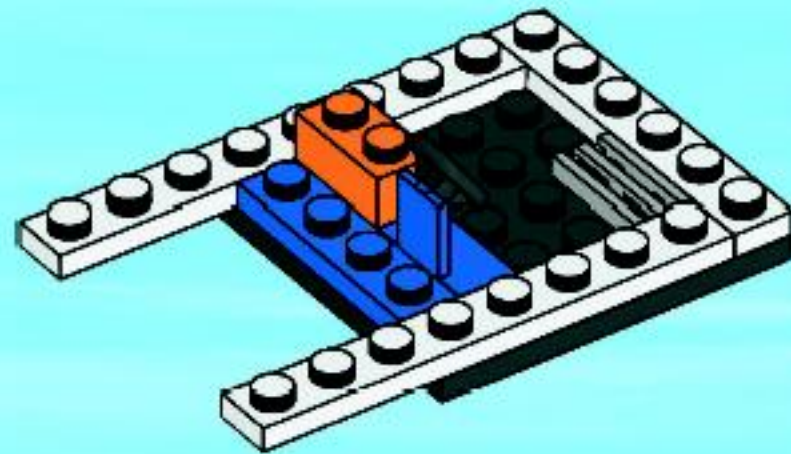

4

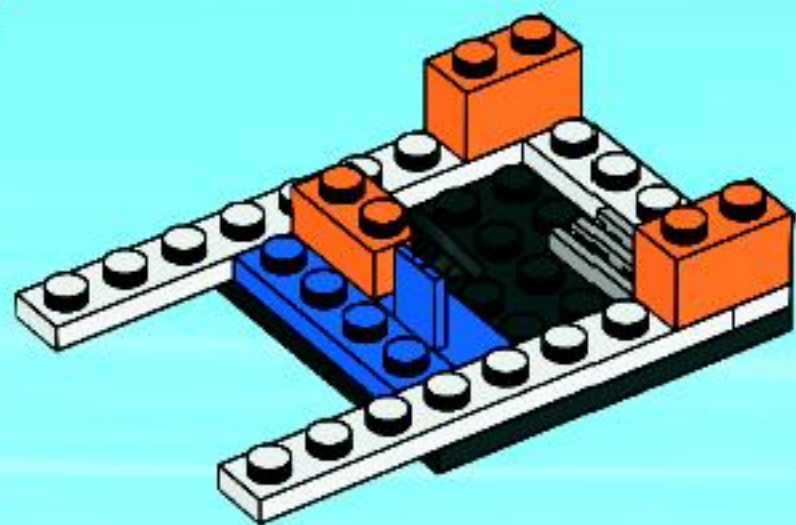

5

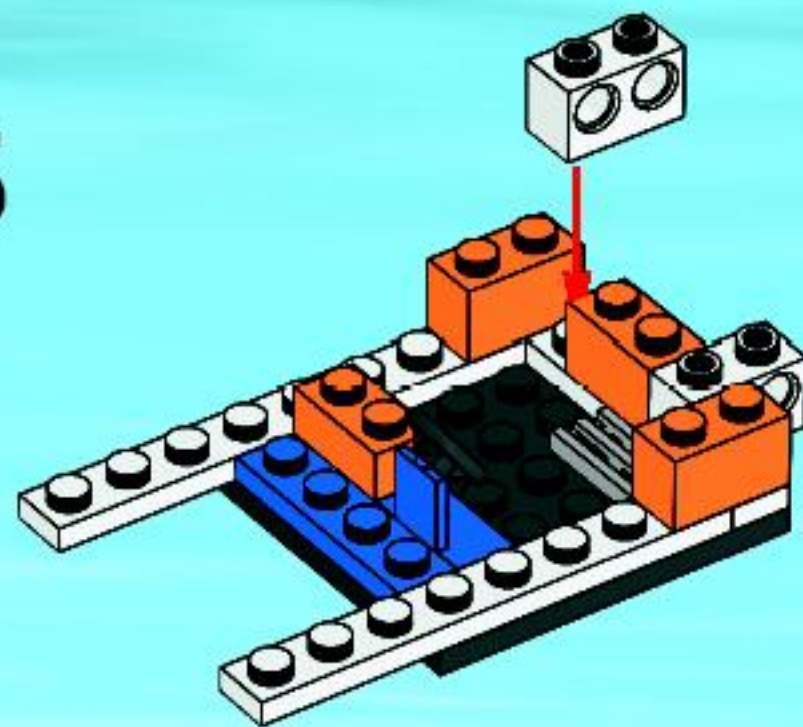



6

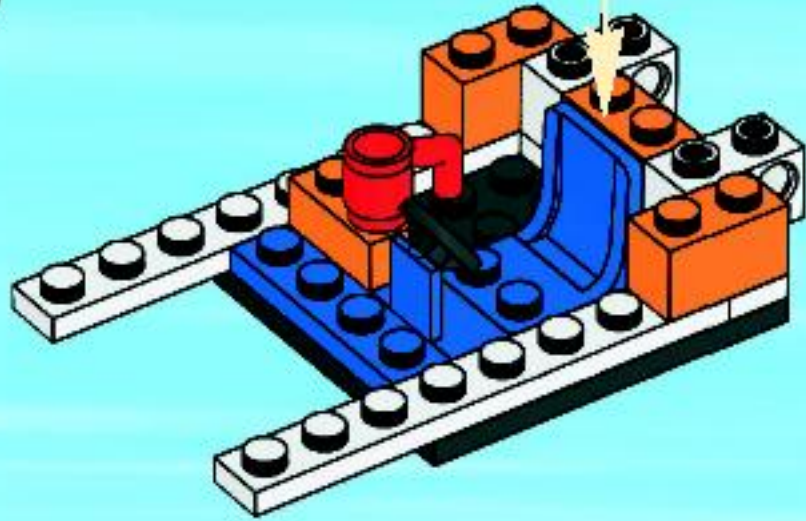

7

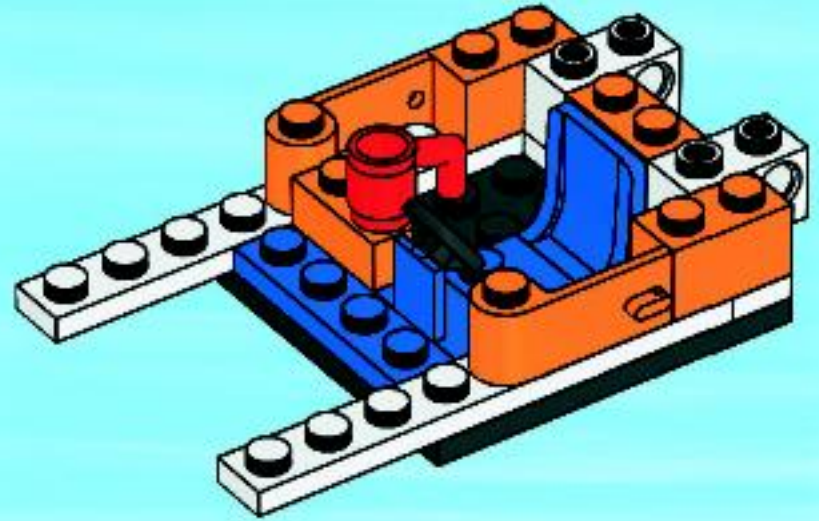

8

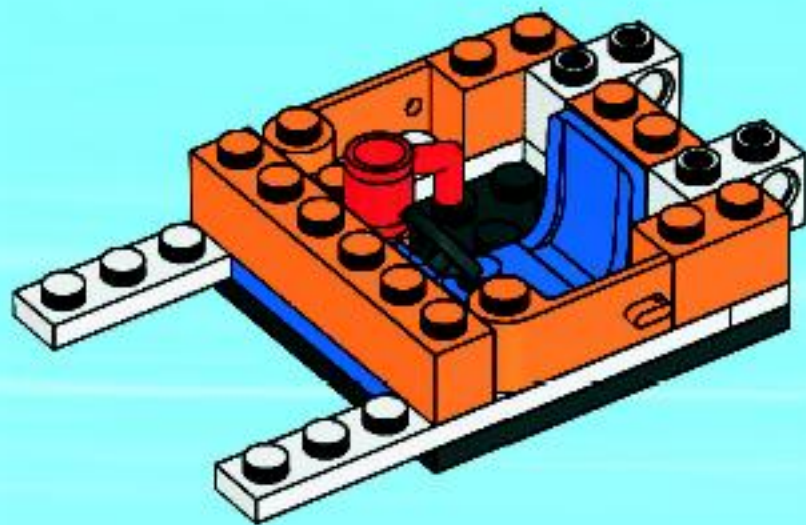

9

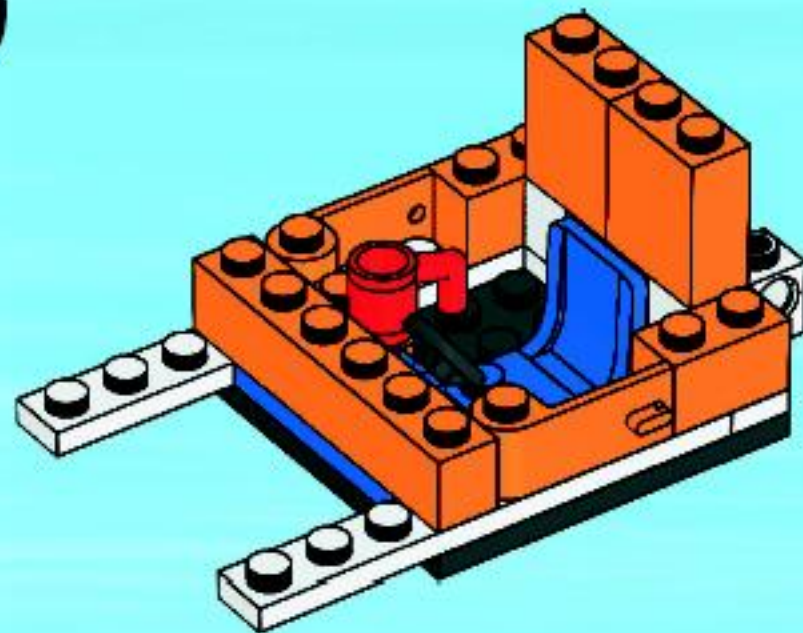

10

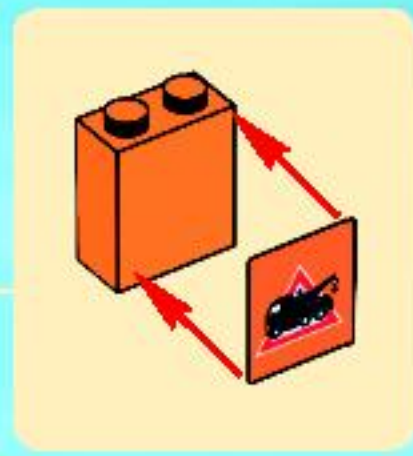
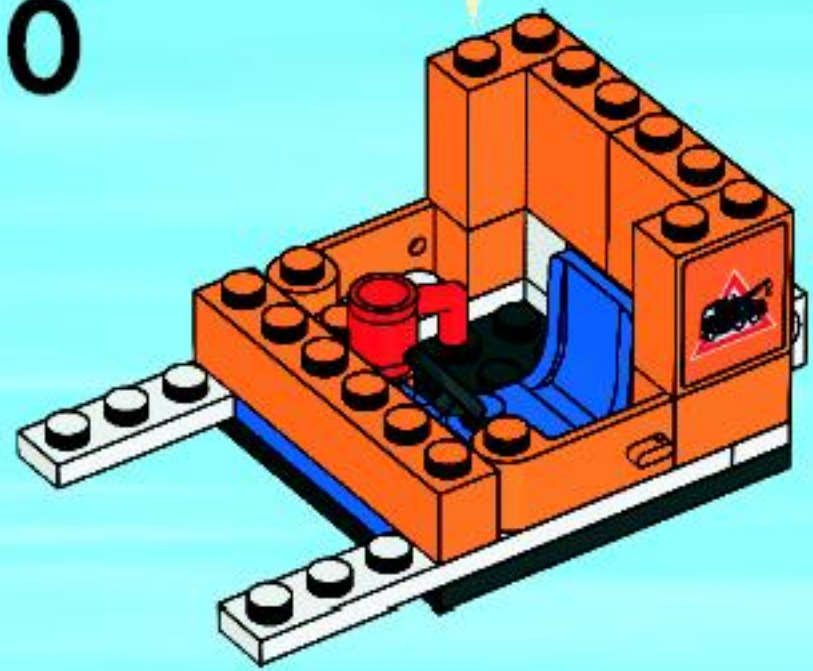
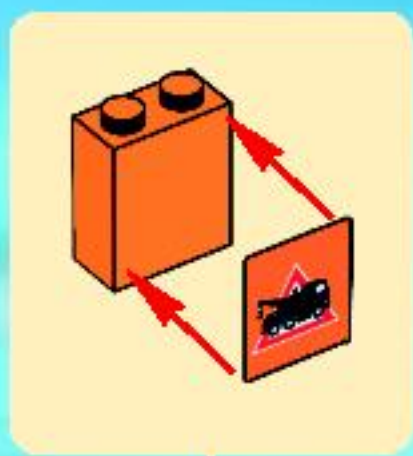

1

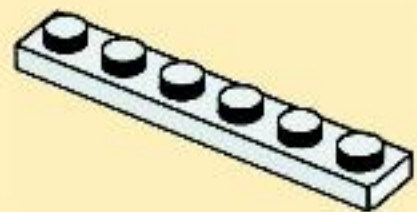

2

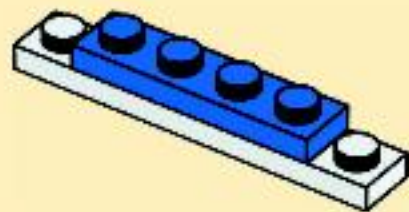

3

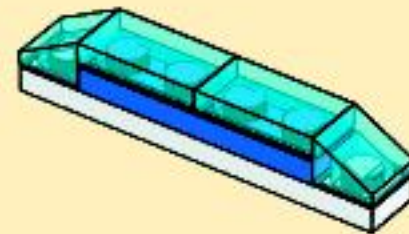

12

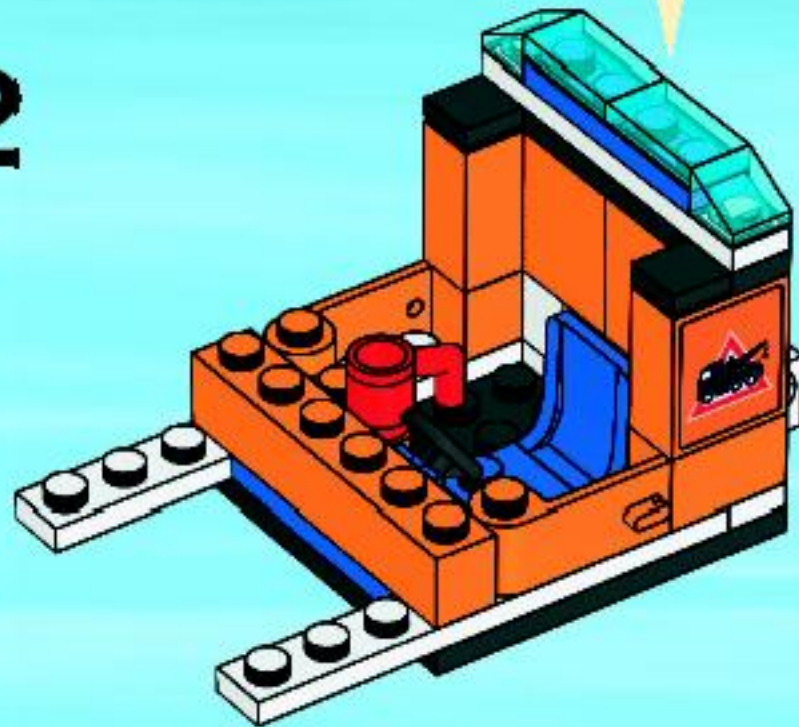

13

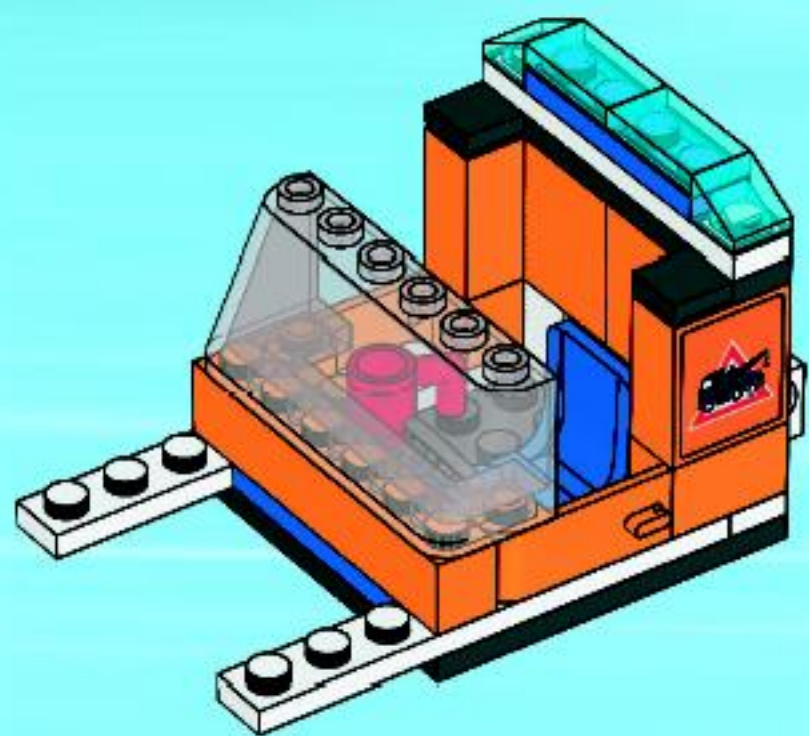

14

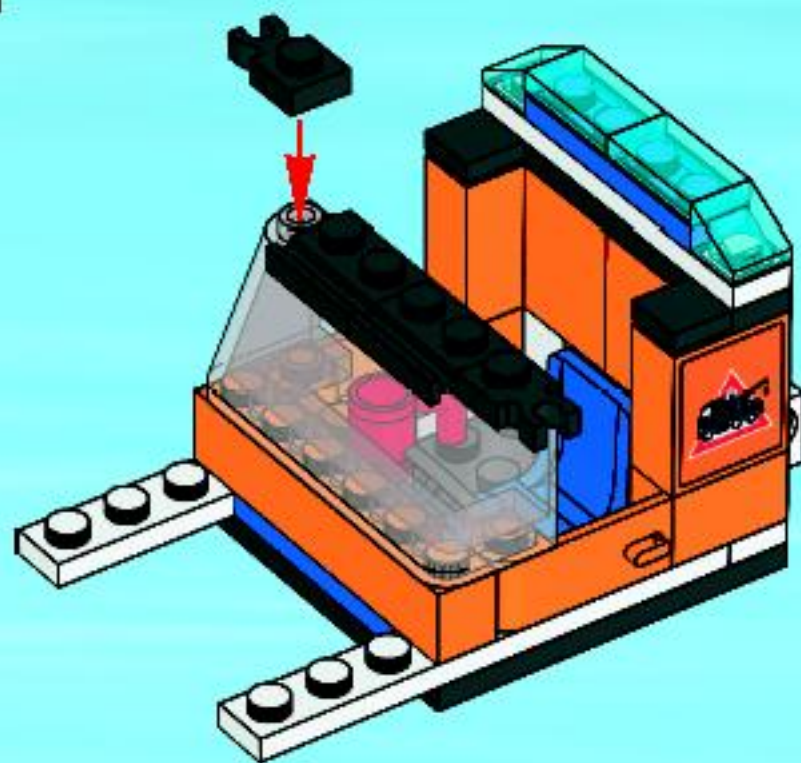

15

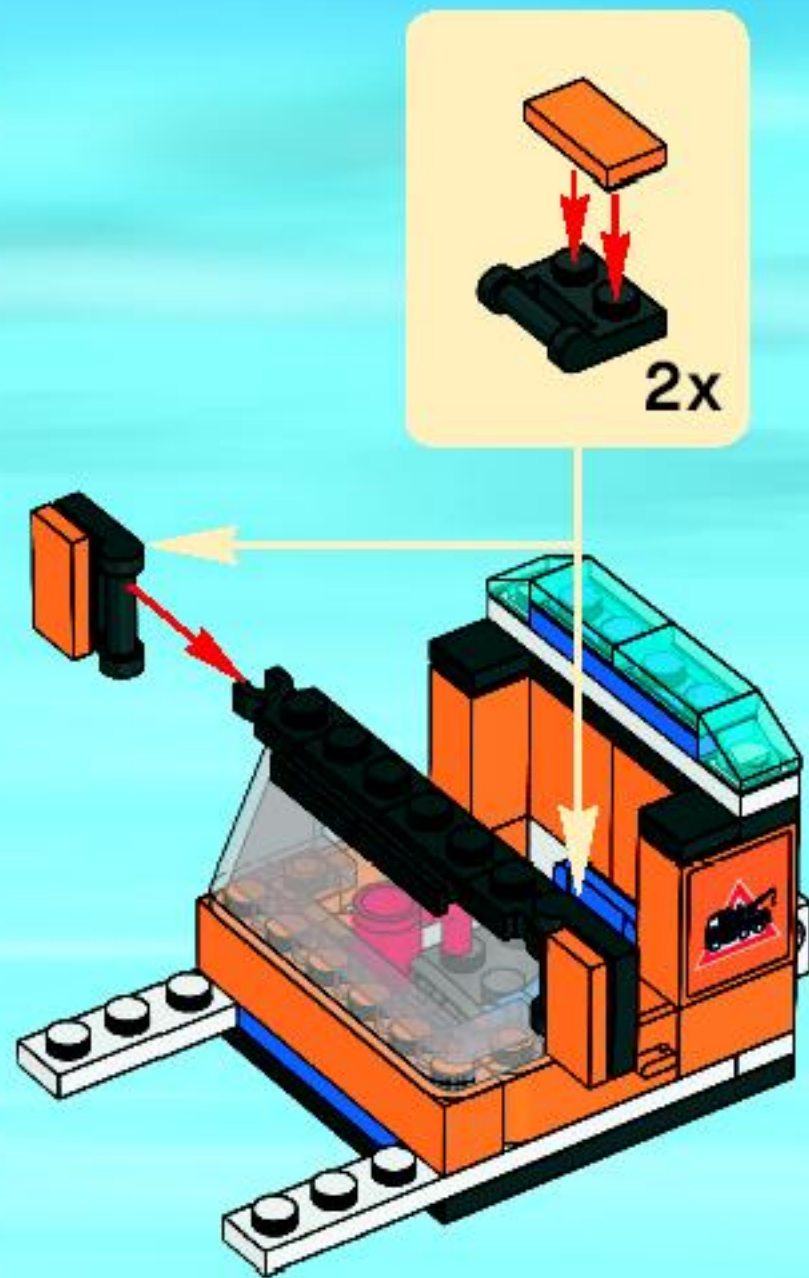

16

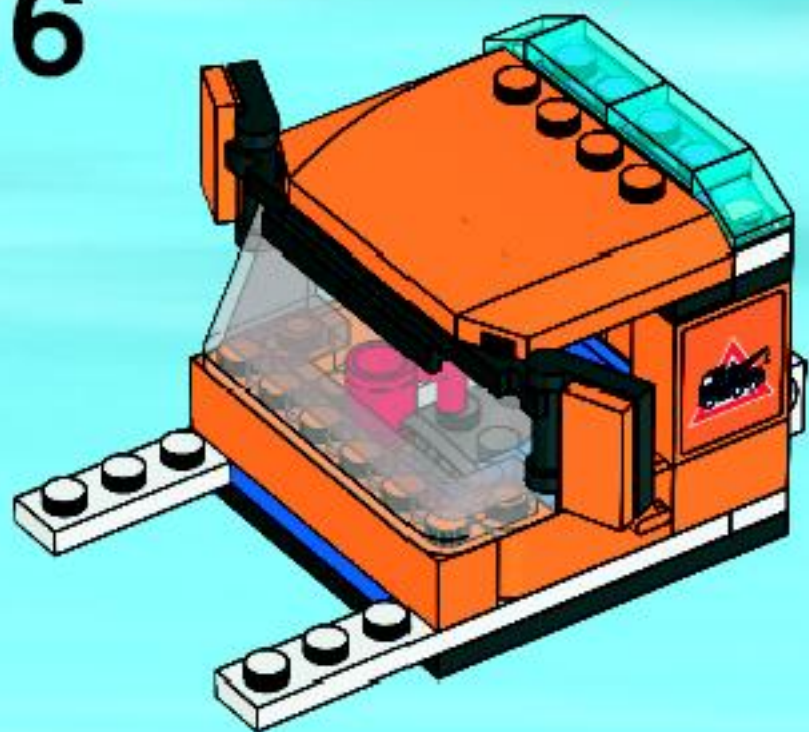

17

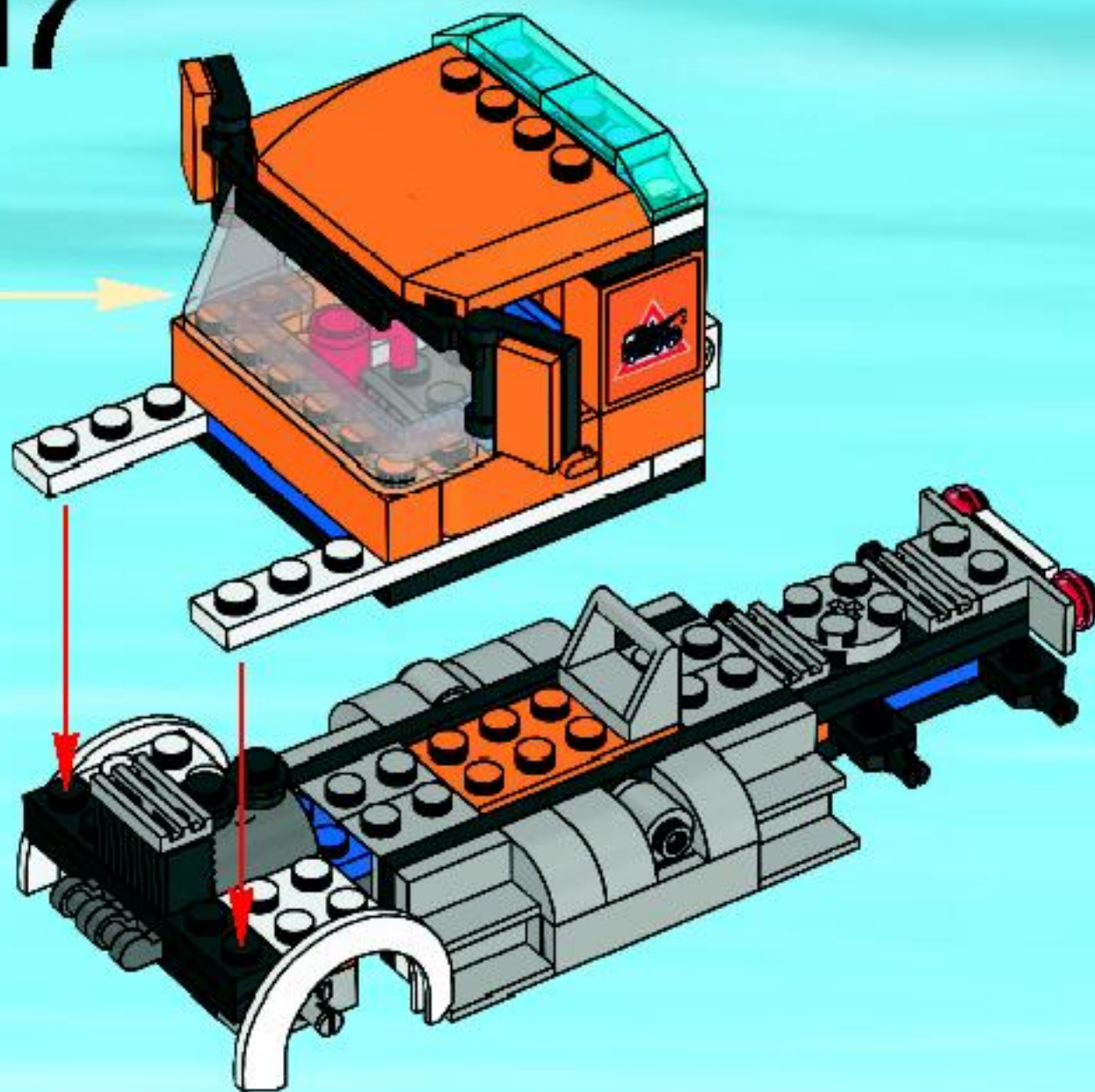

18

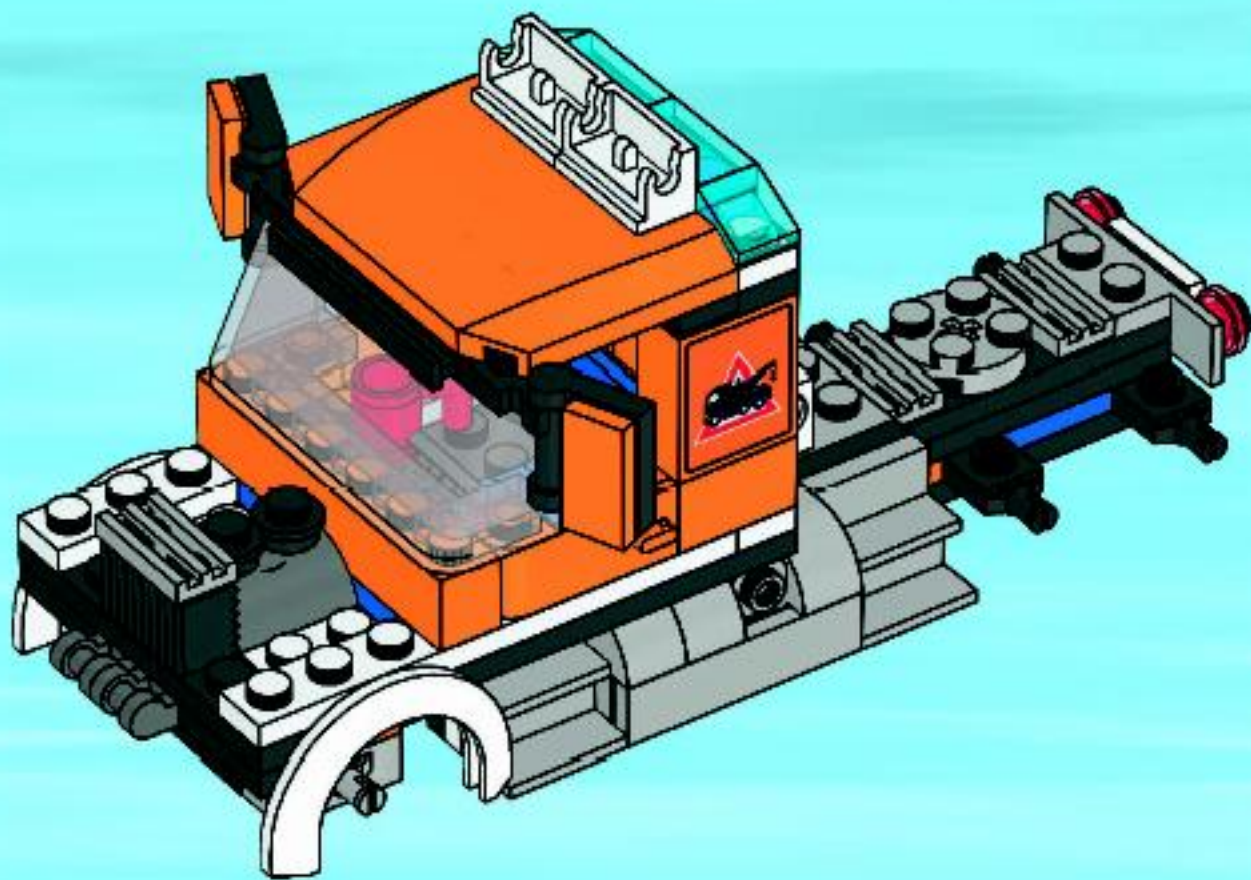

19

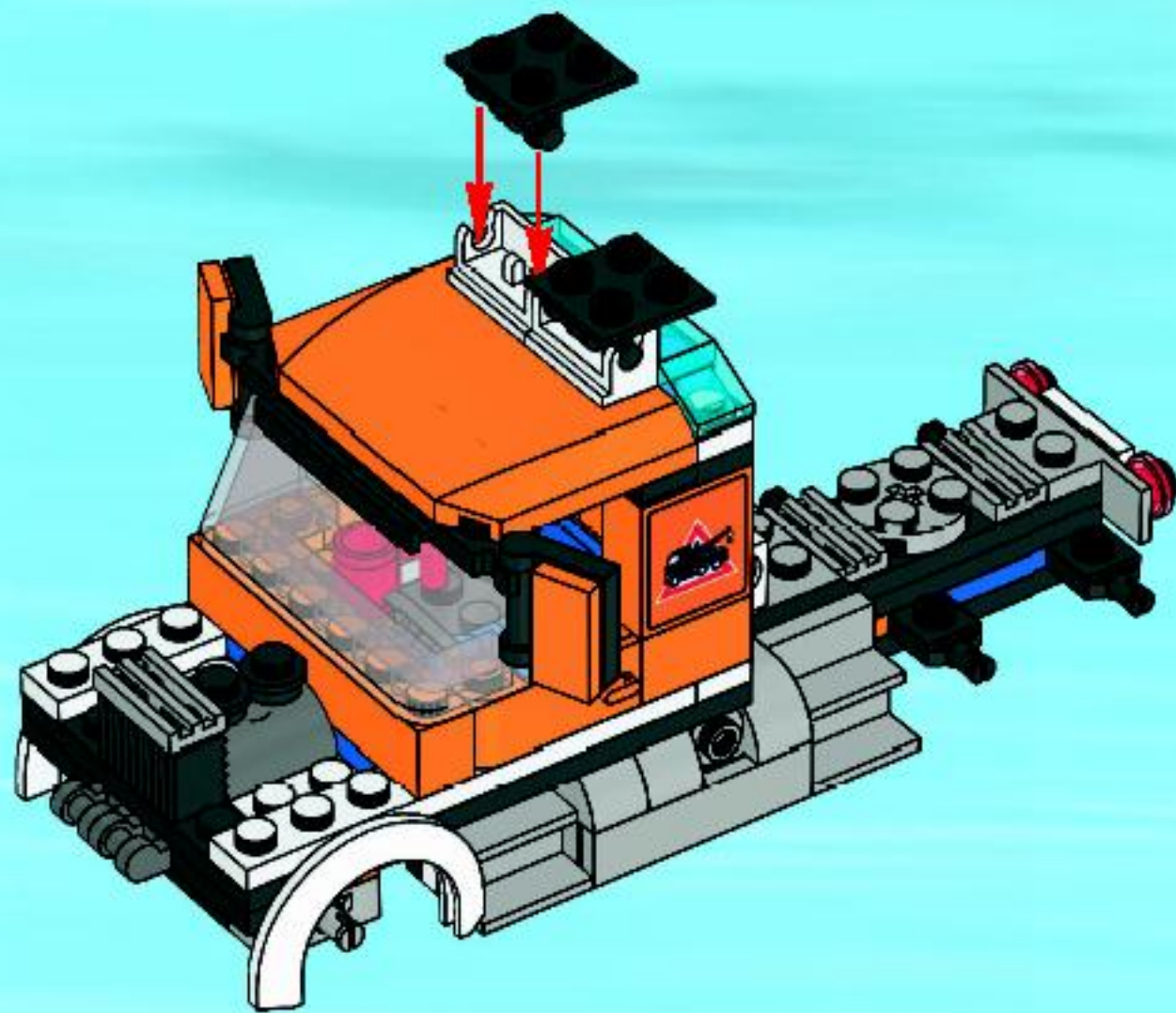

1

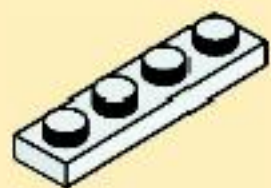

2

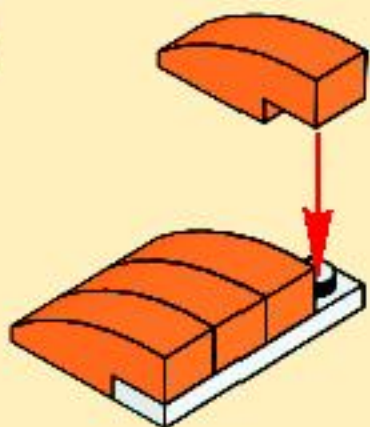

20

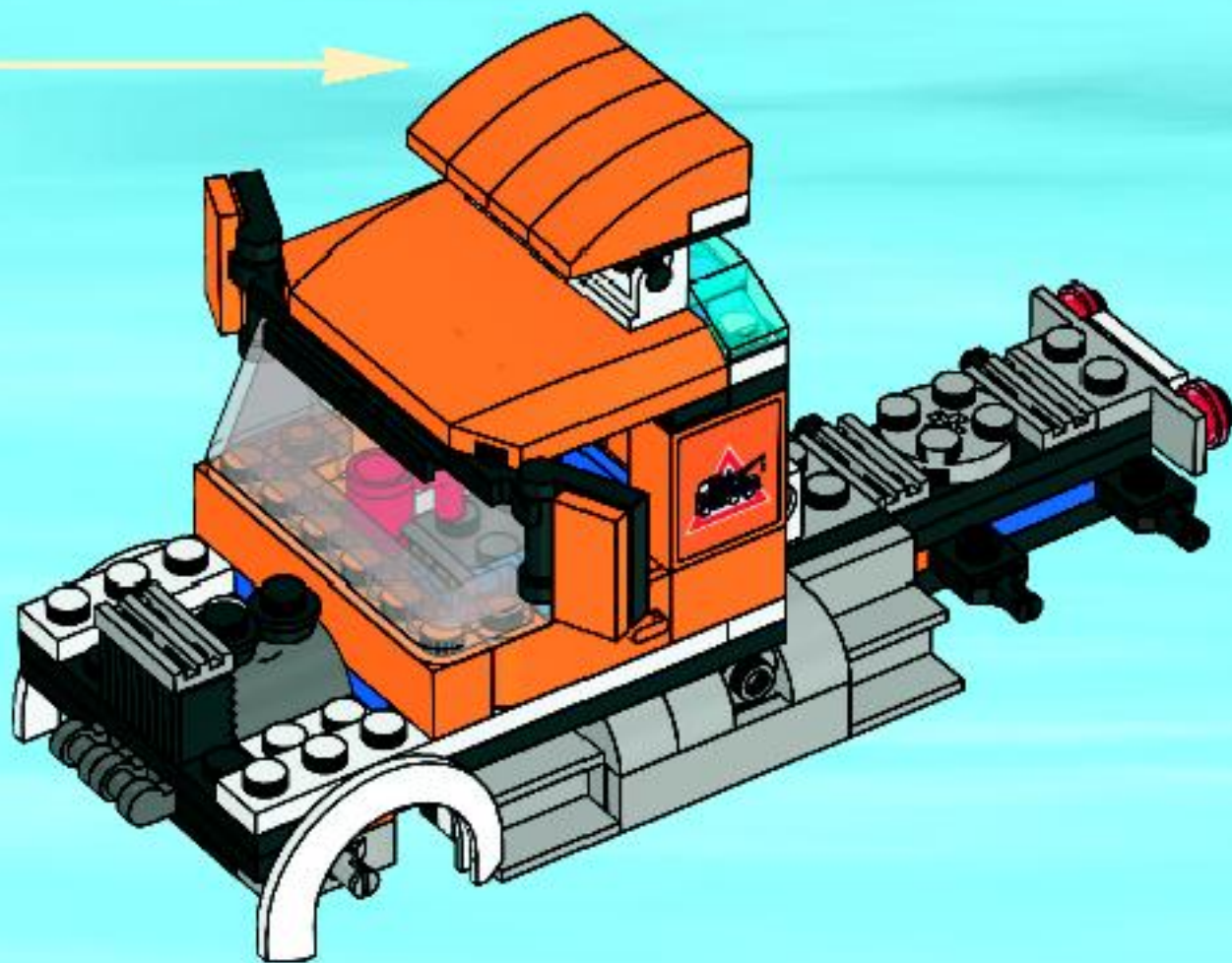

21

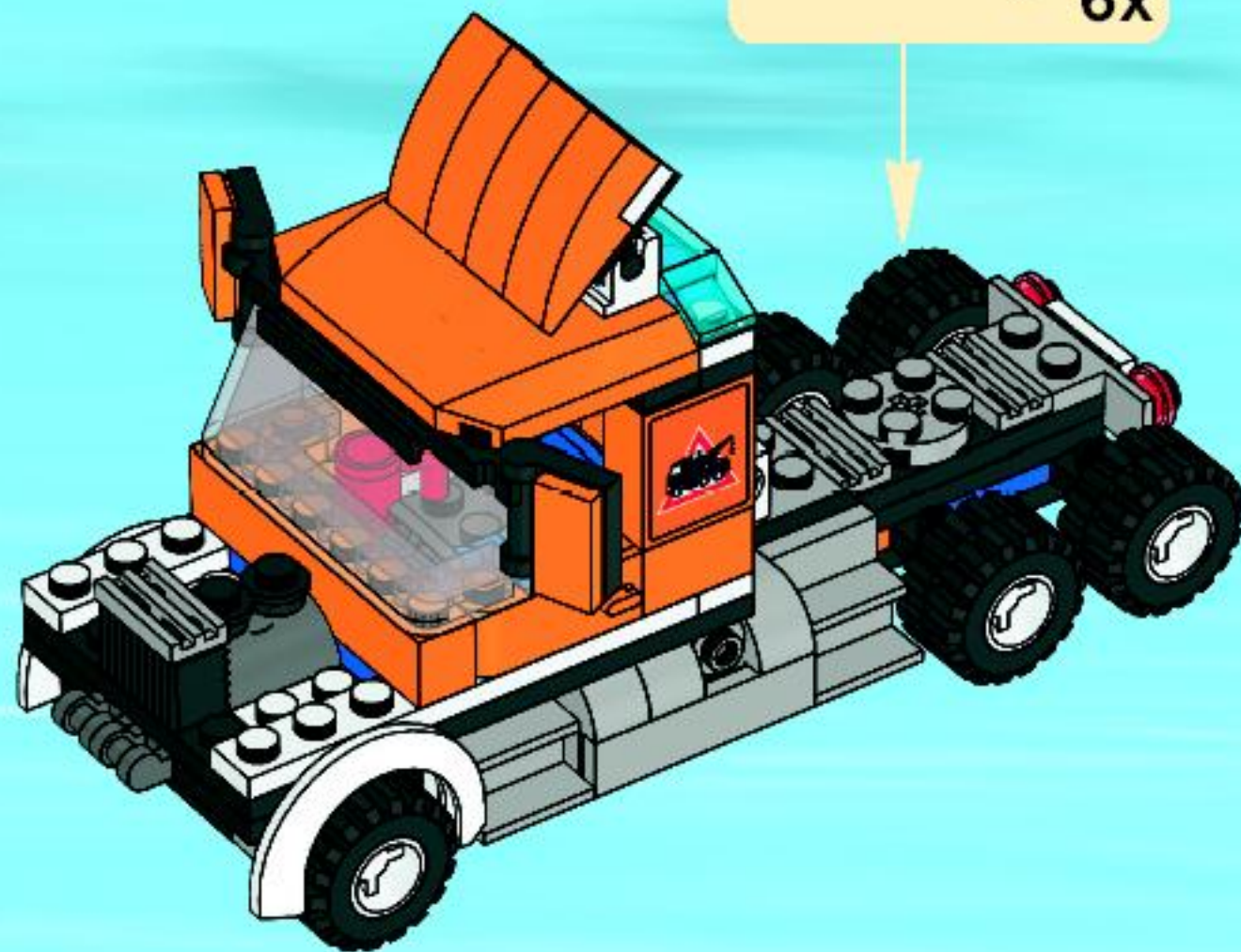



1



2

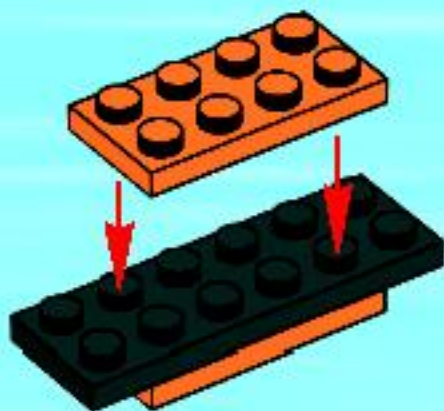

3

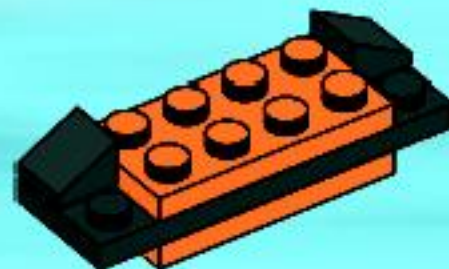

4



5

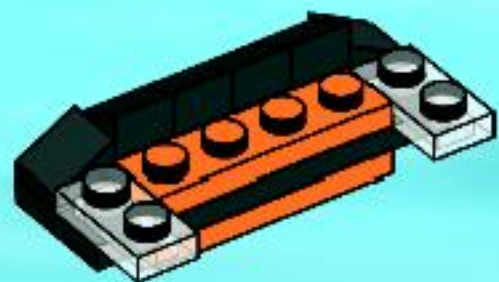

7

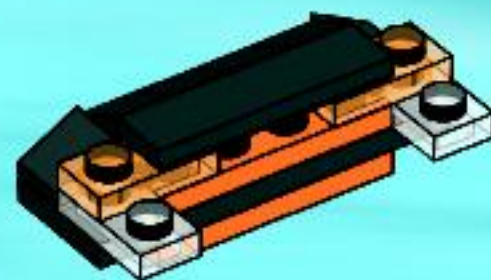

6



8



22





1

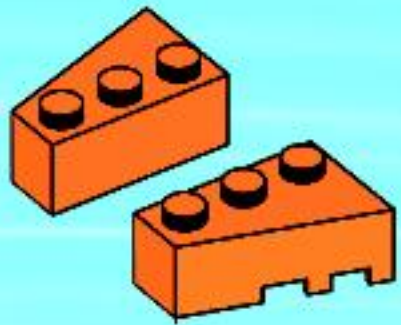

2

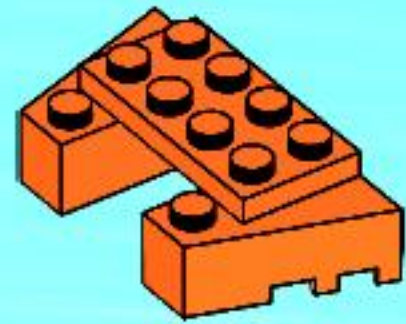

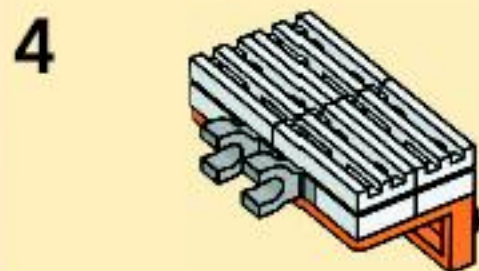
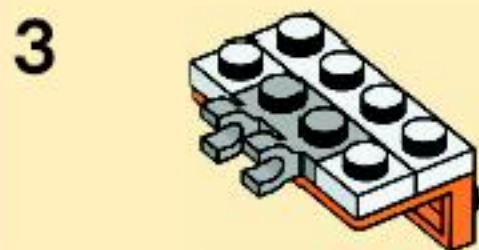
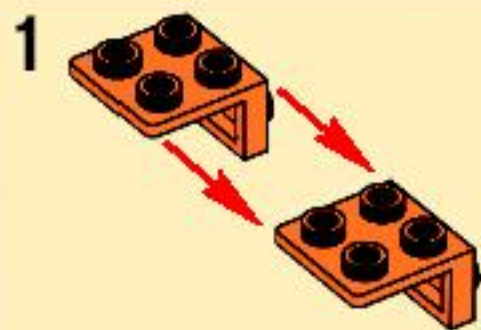

3

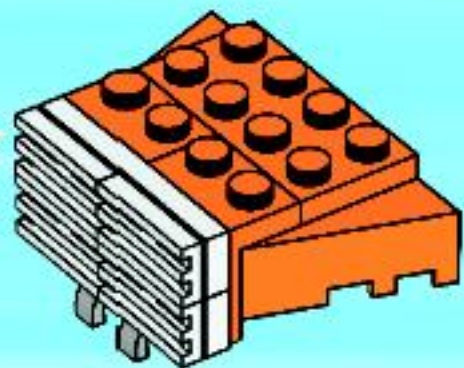

4

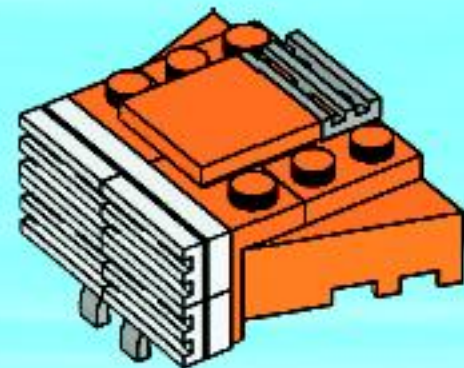

23



24





+

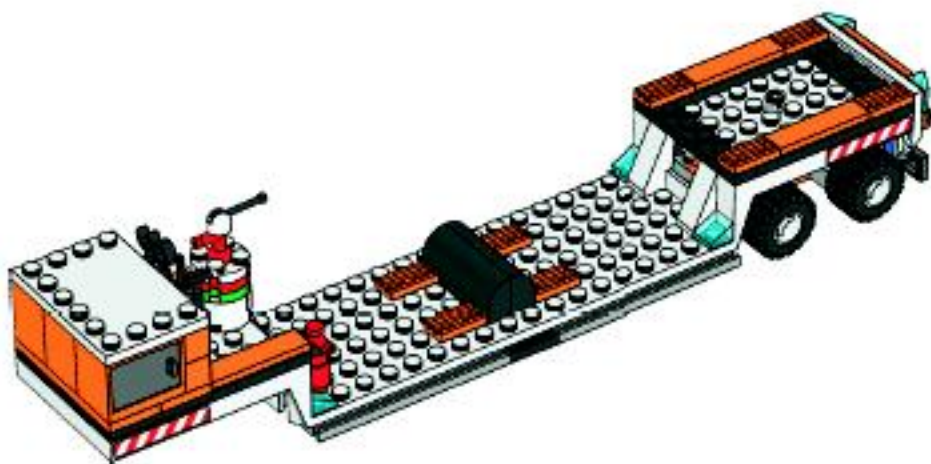

1

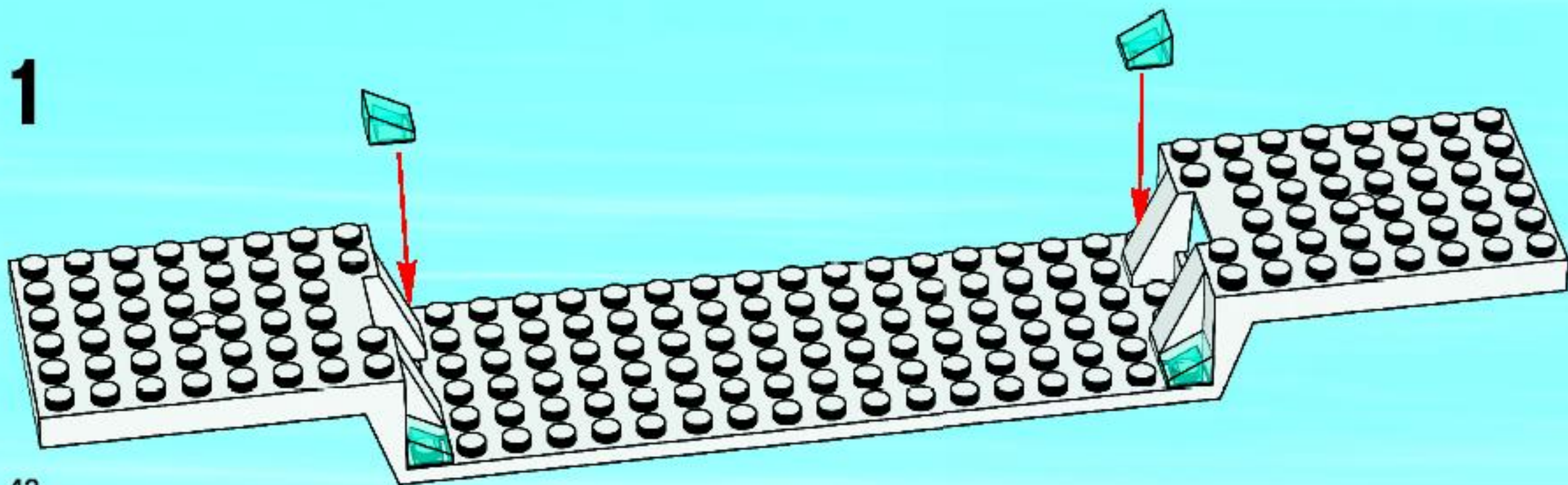

2

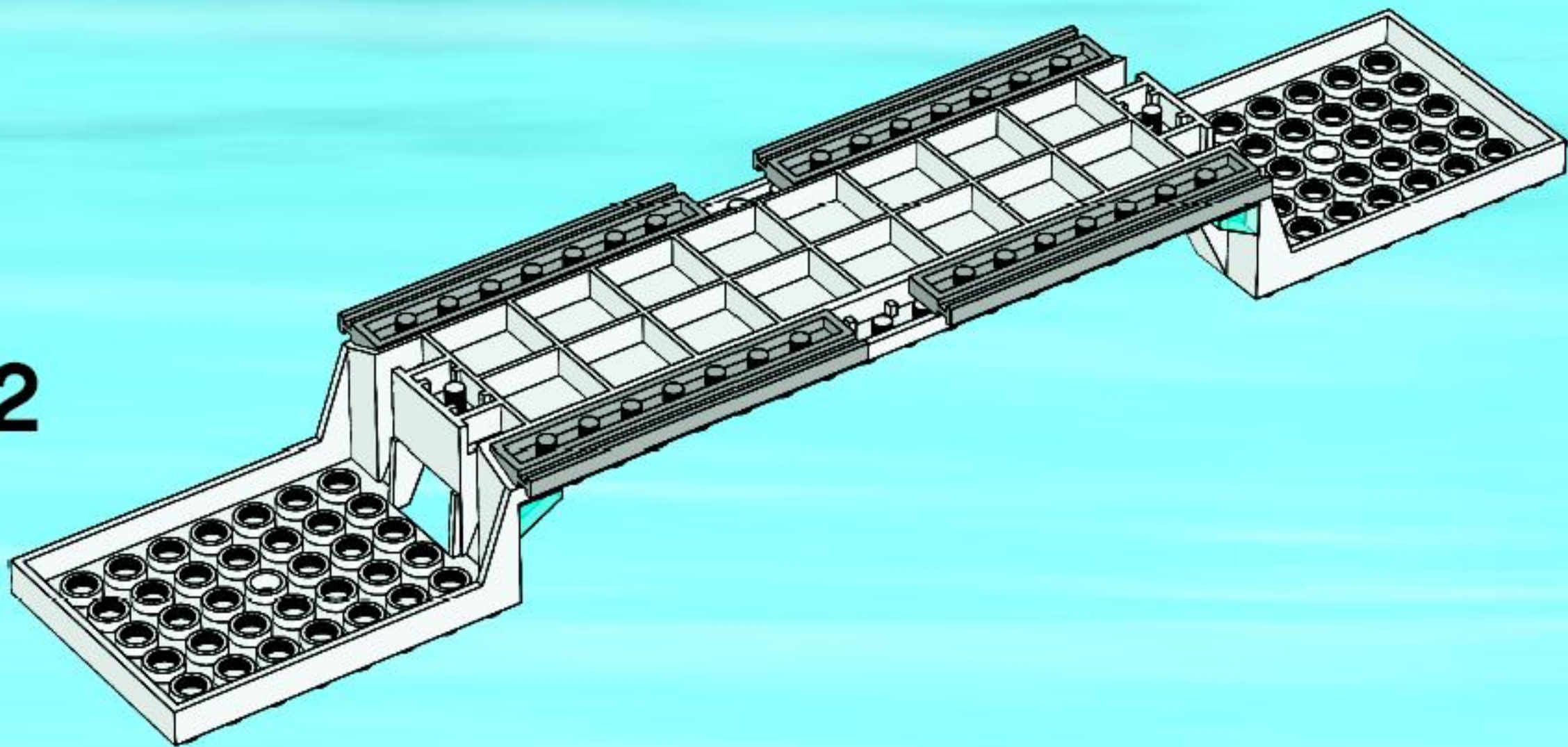

3

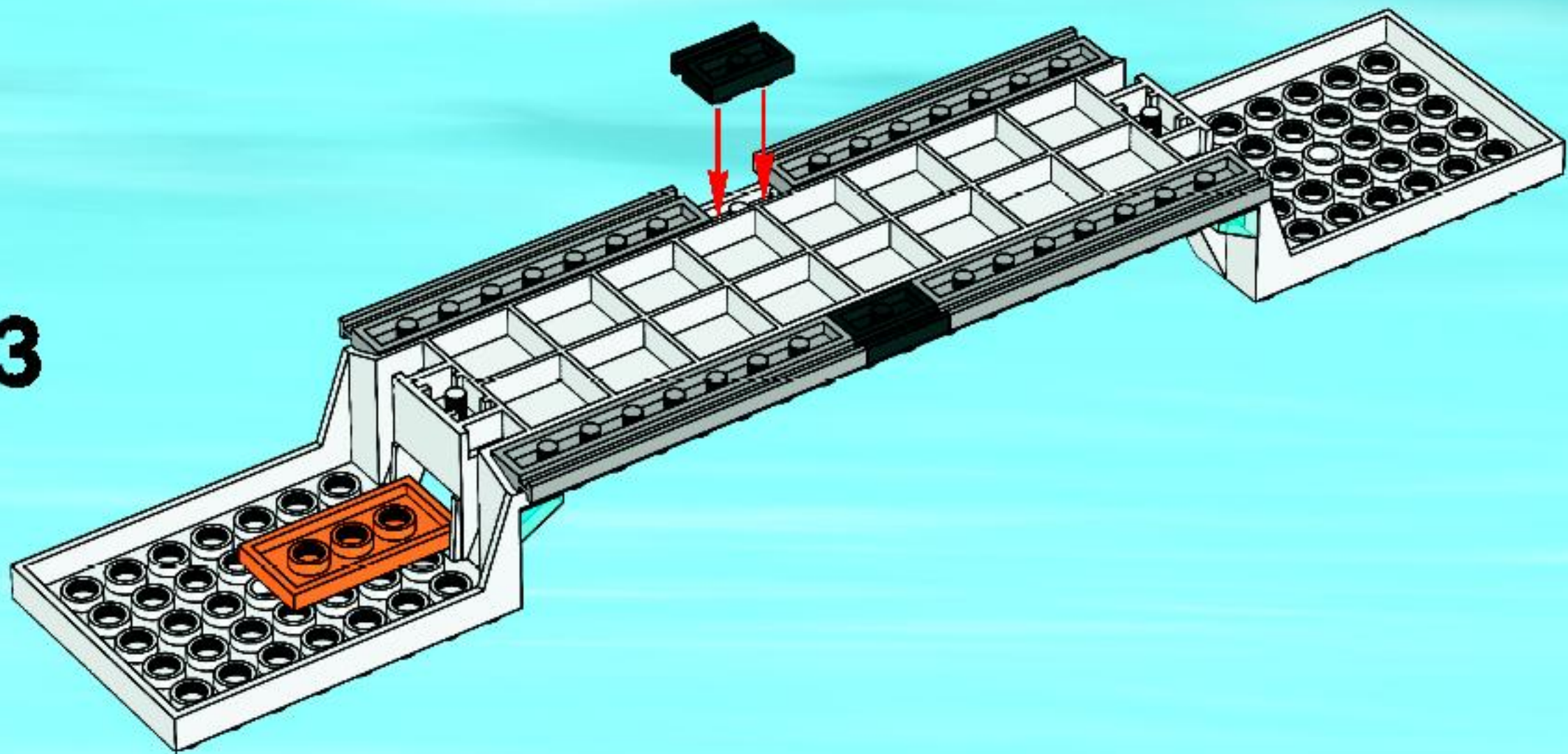

4

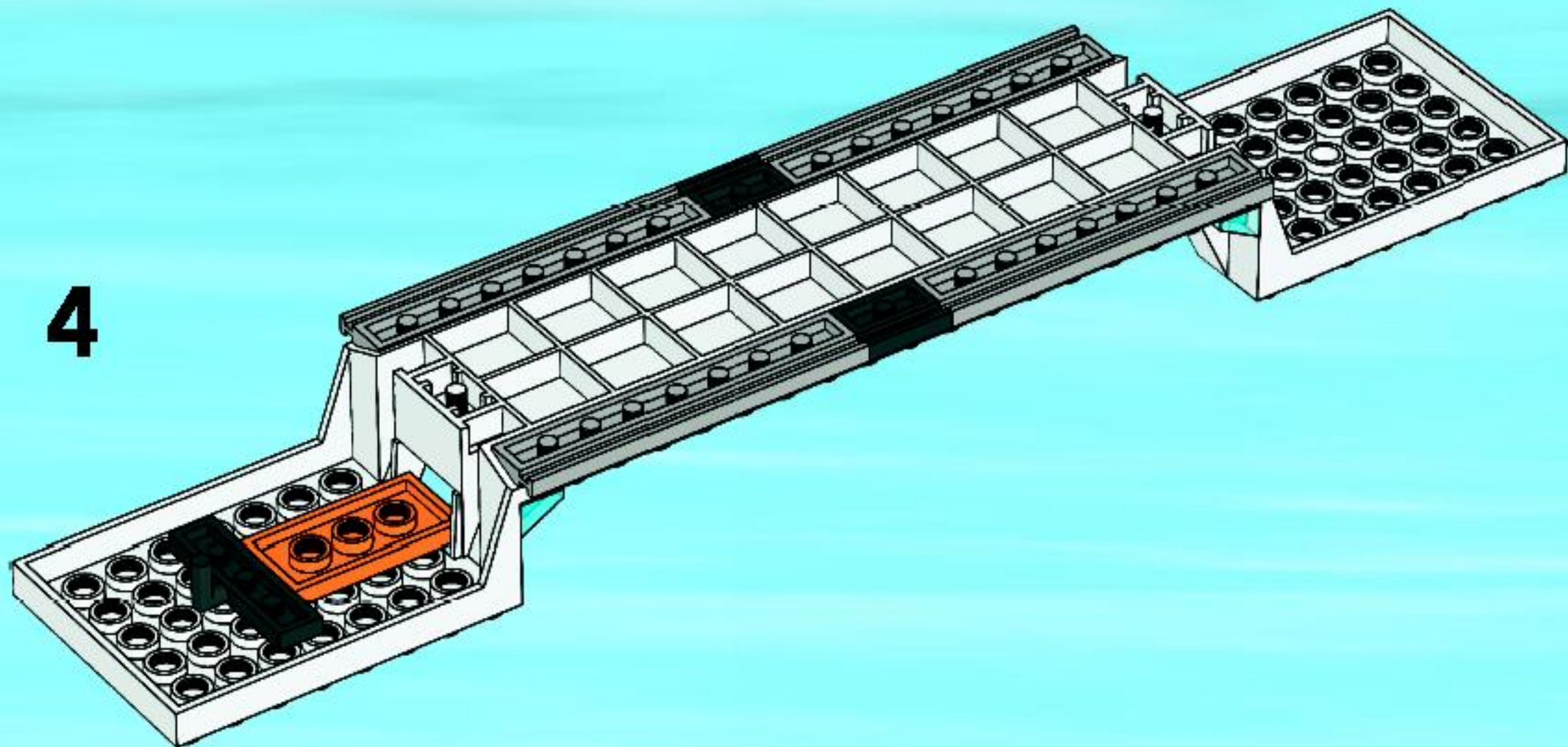

5

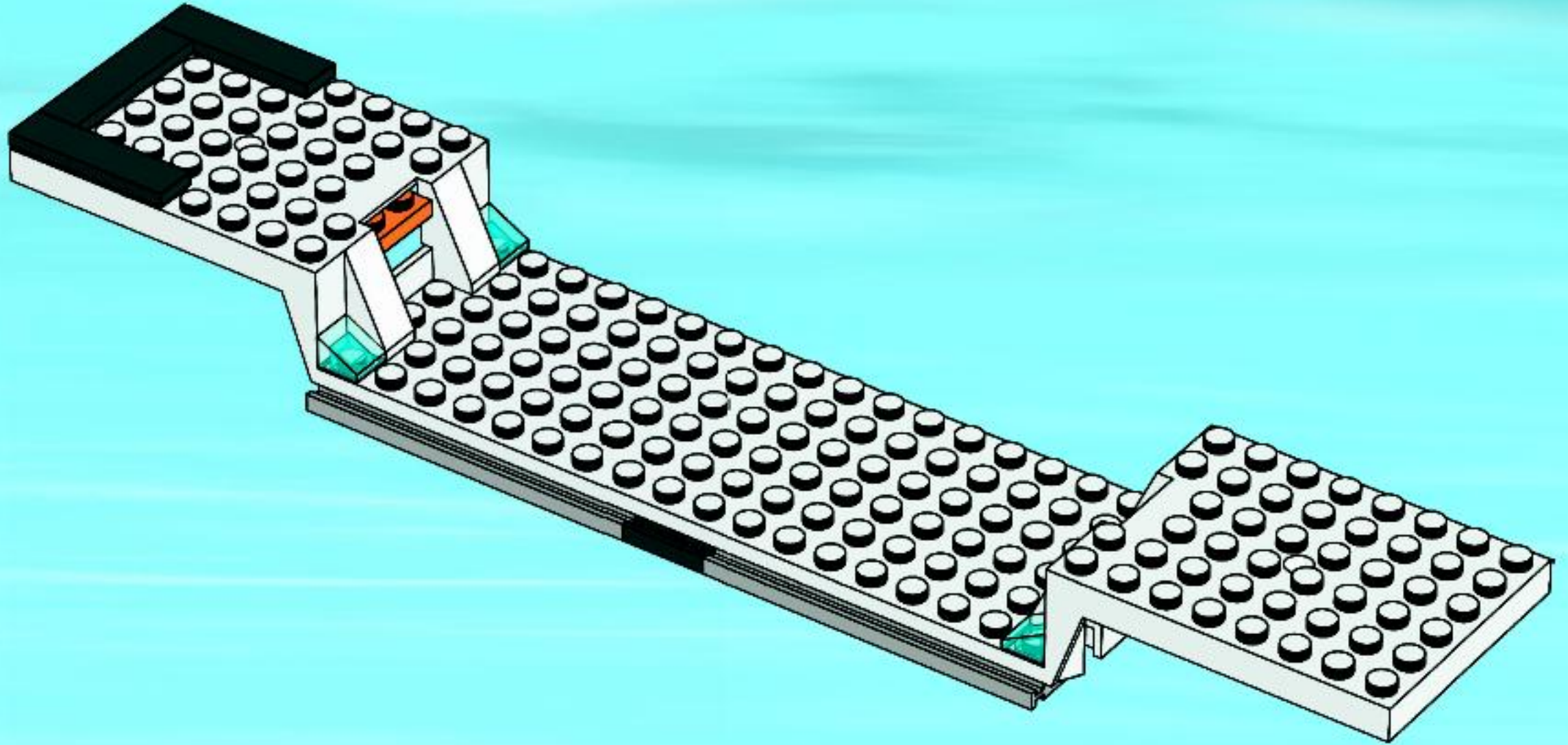

6

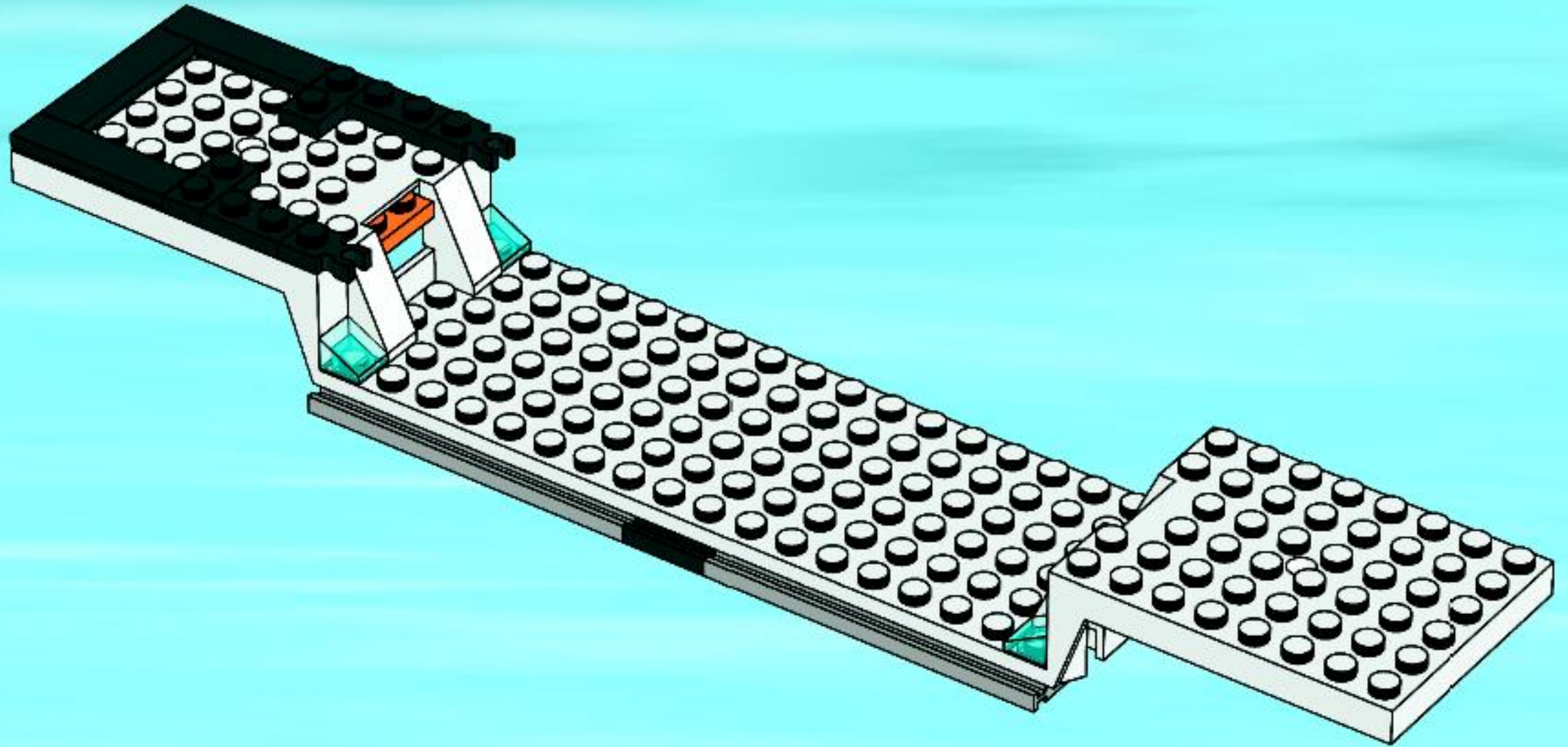



1

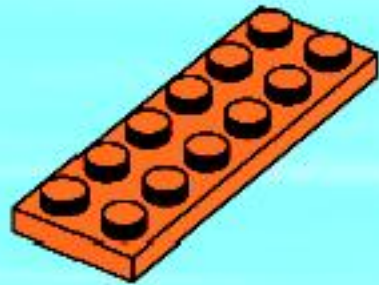

2

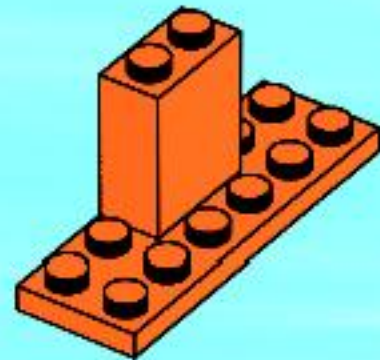

1

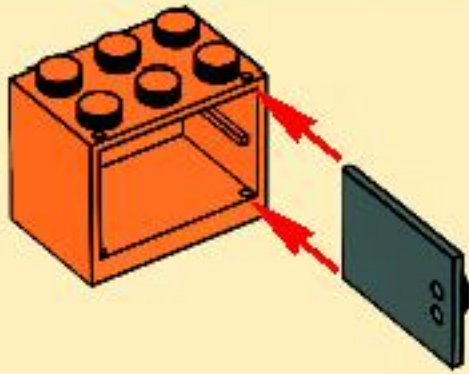

2

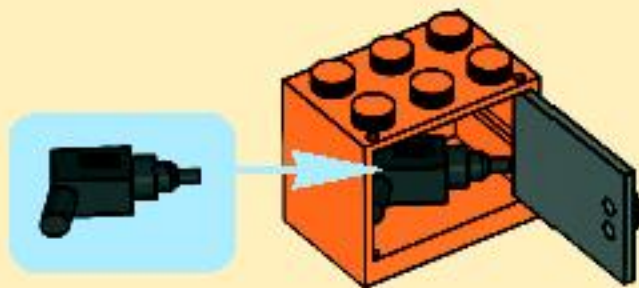

3



3

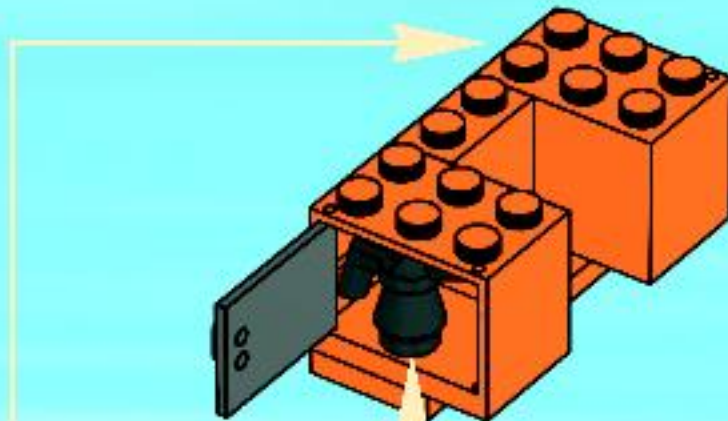

4

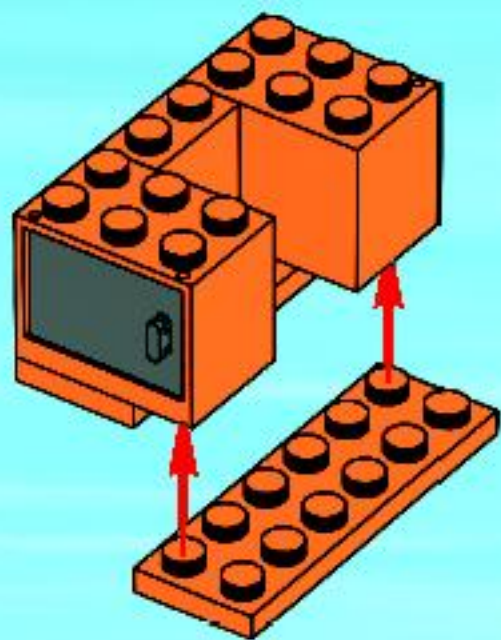

5

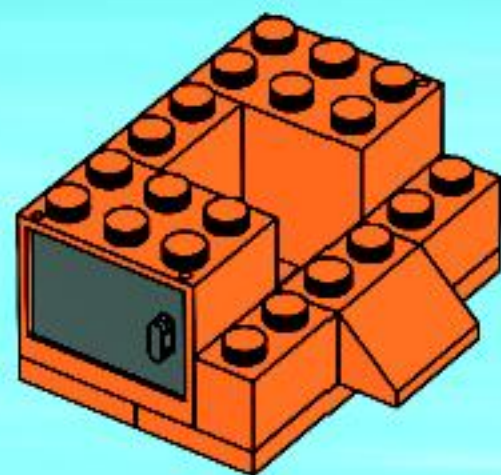

6

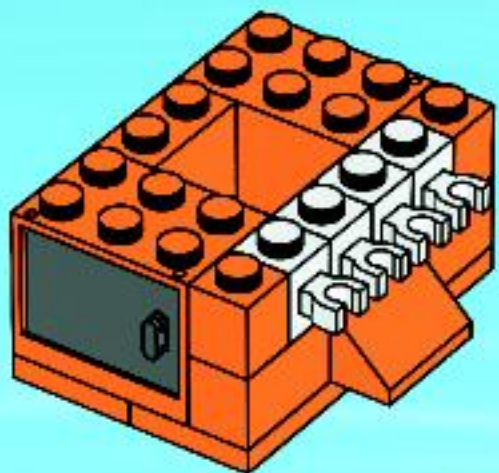

7

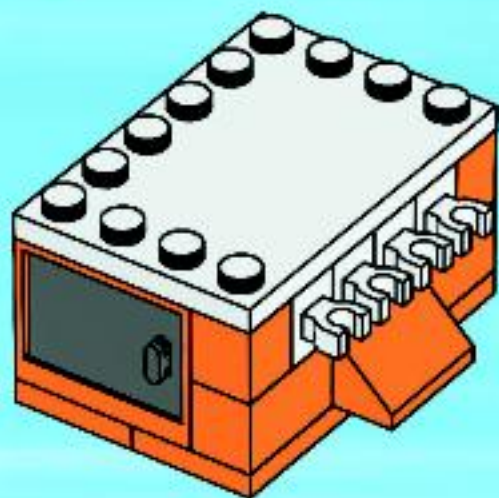

8



8

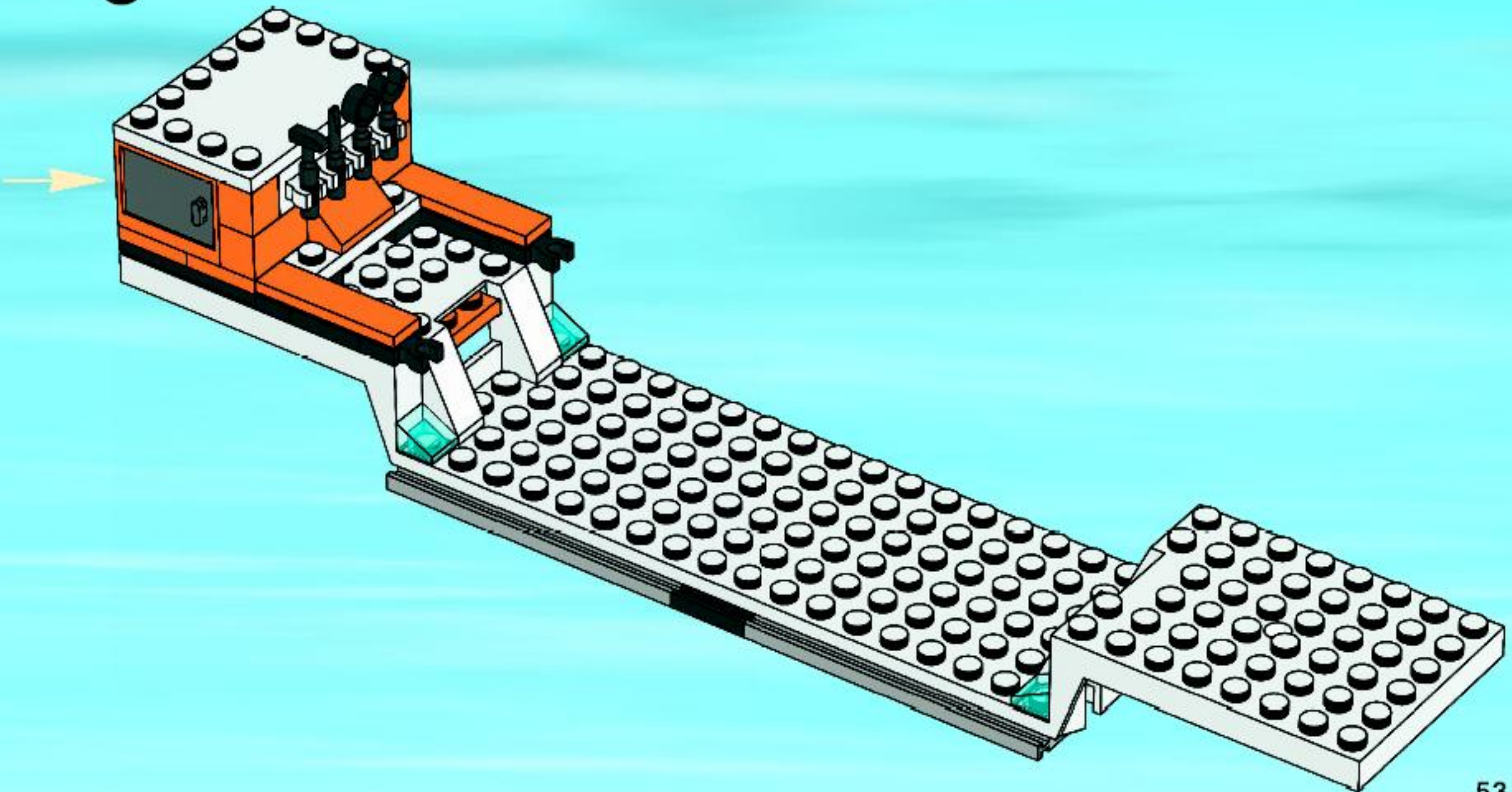

1



2



3



4



9

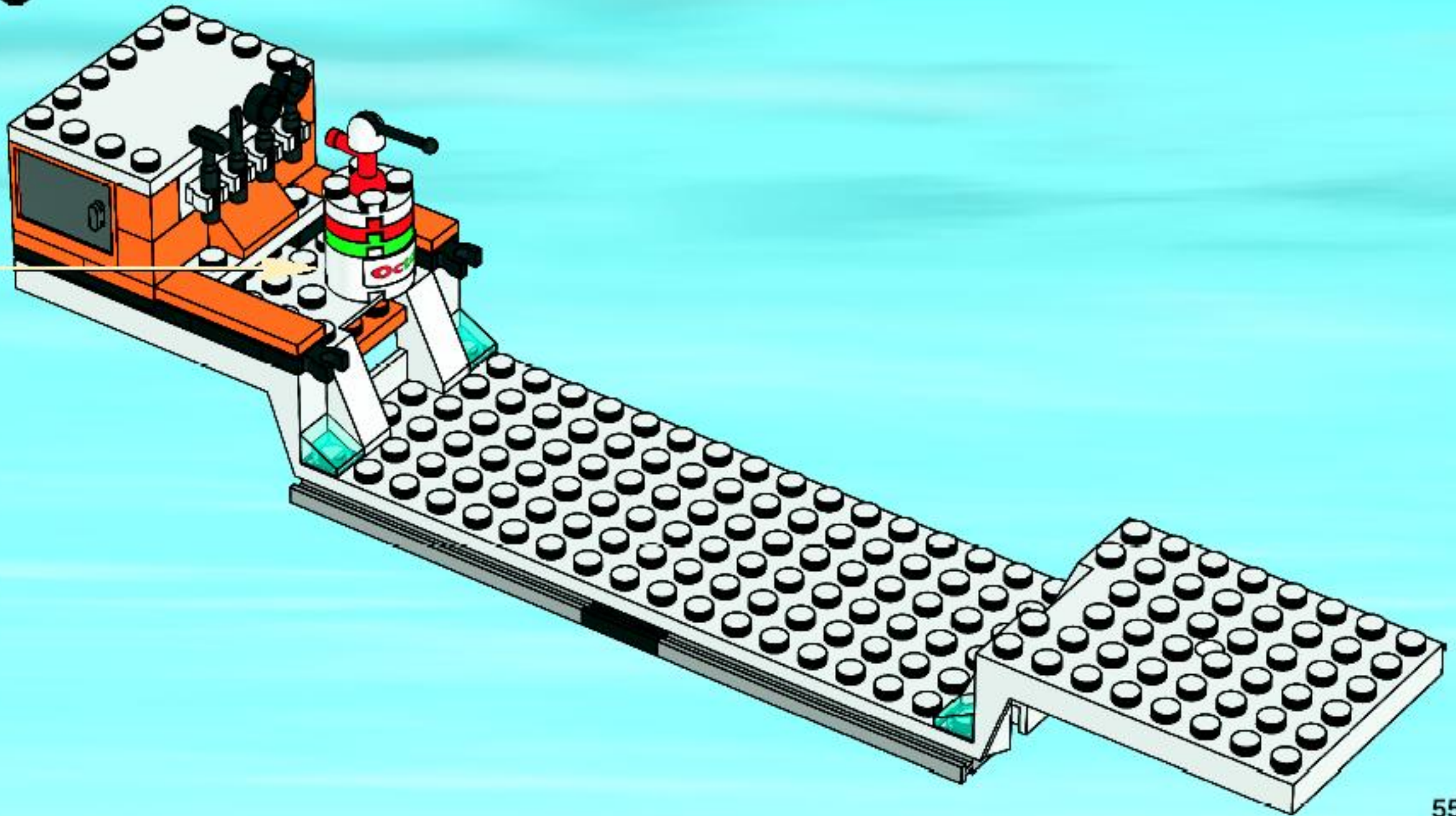

10

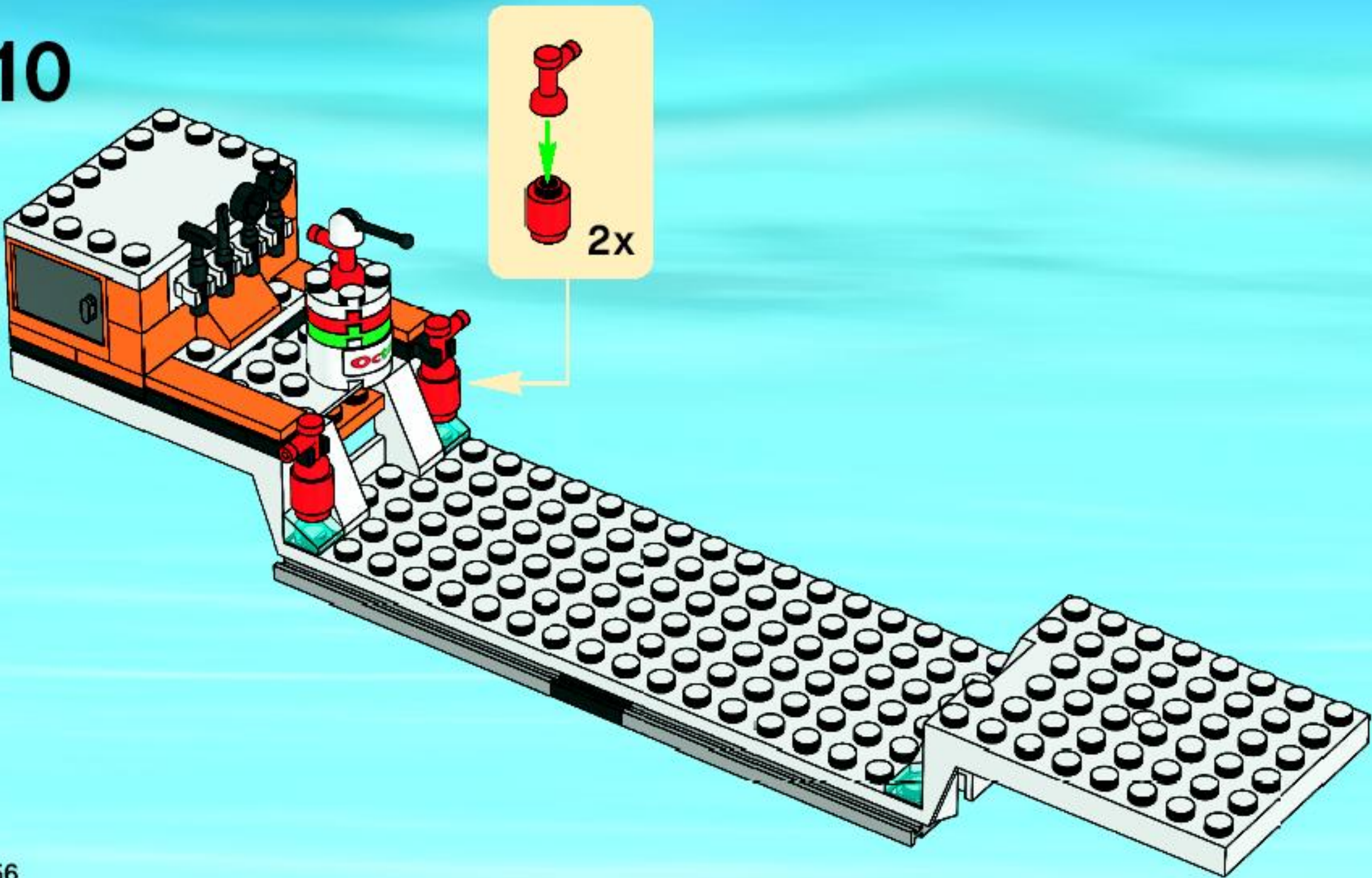

11

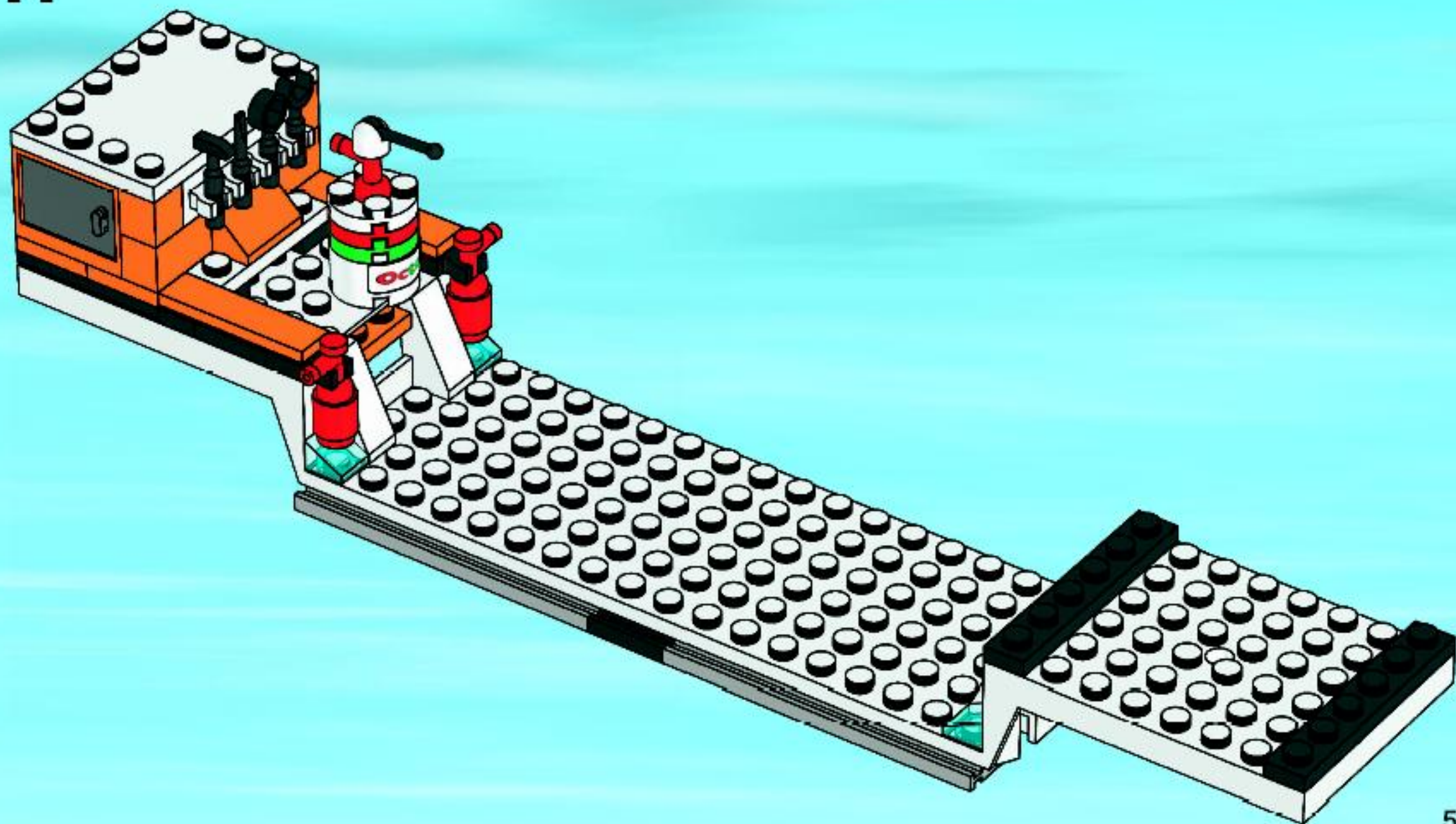

12

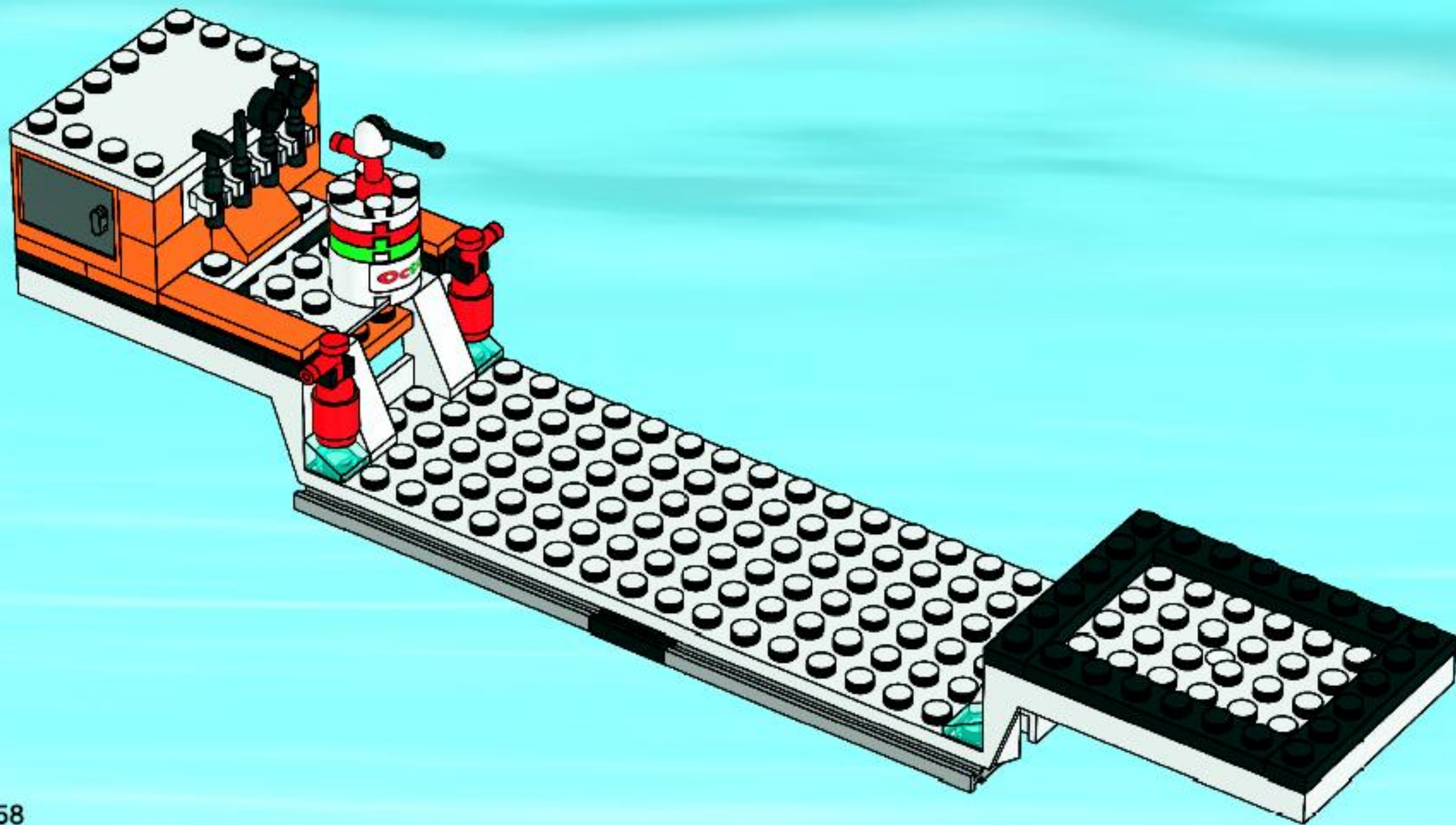

13

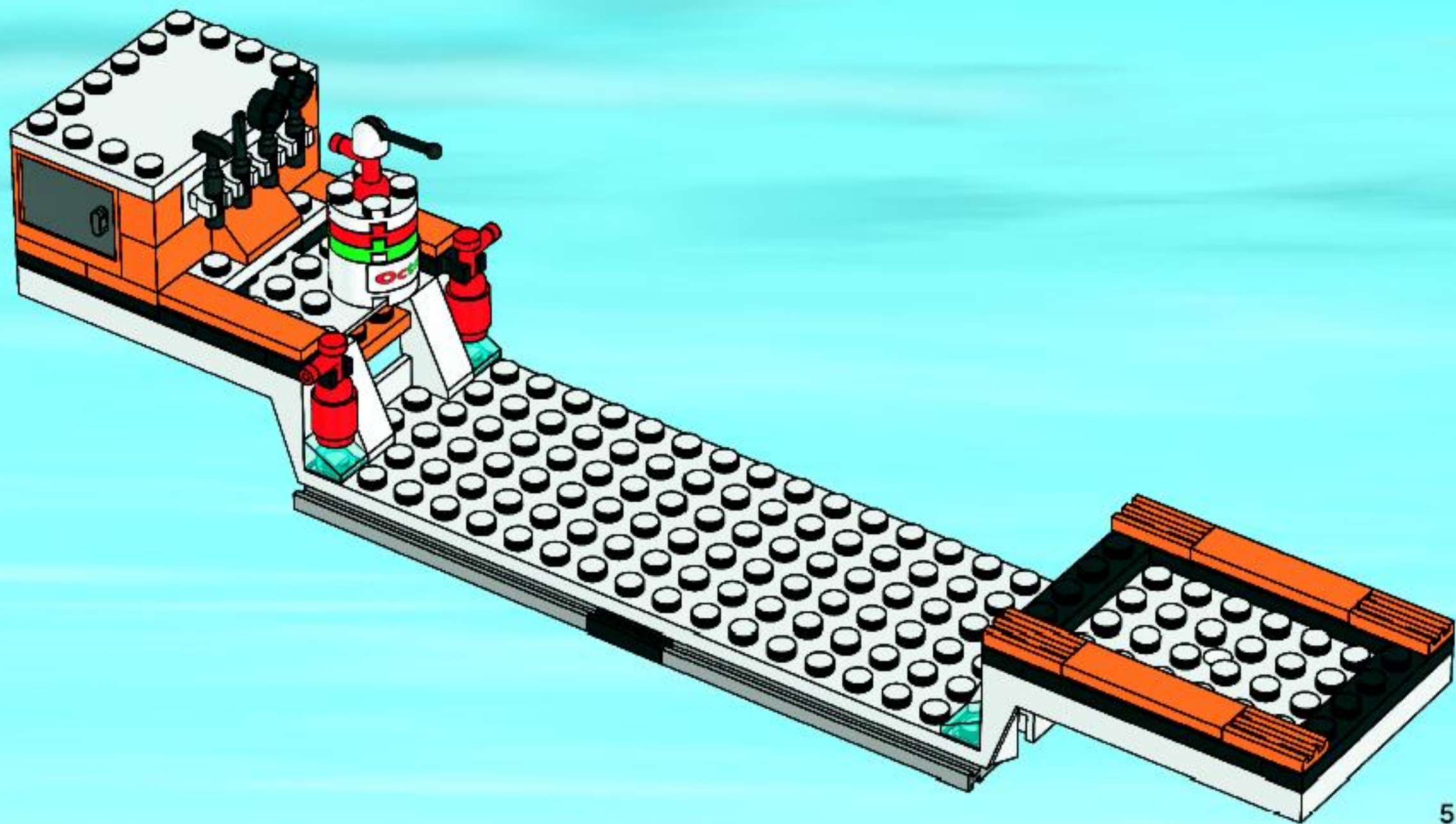



1

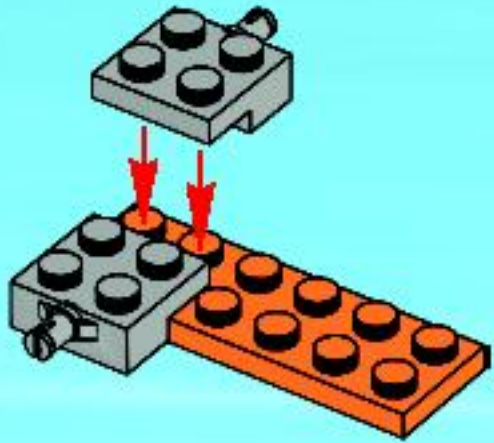

2

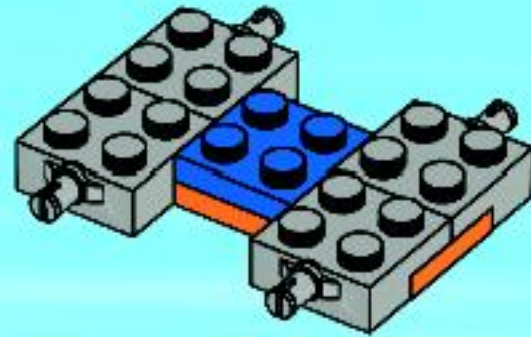

3

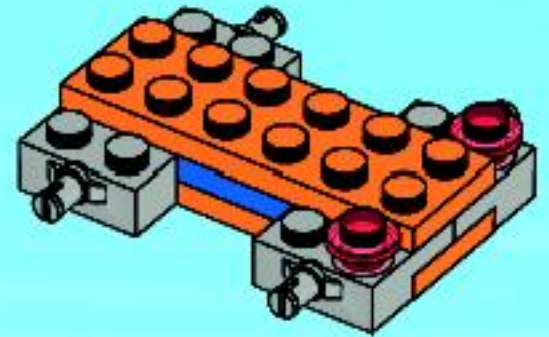

4

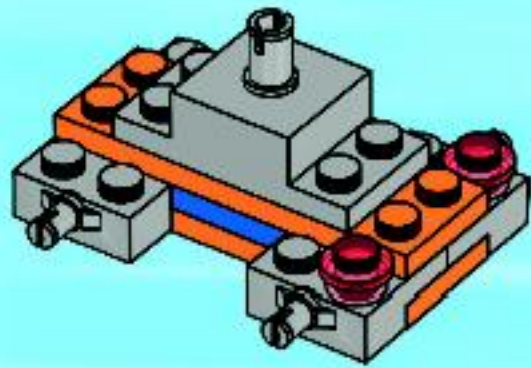

5

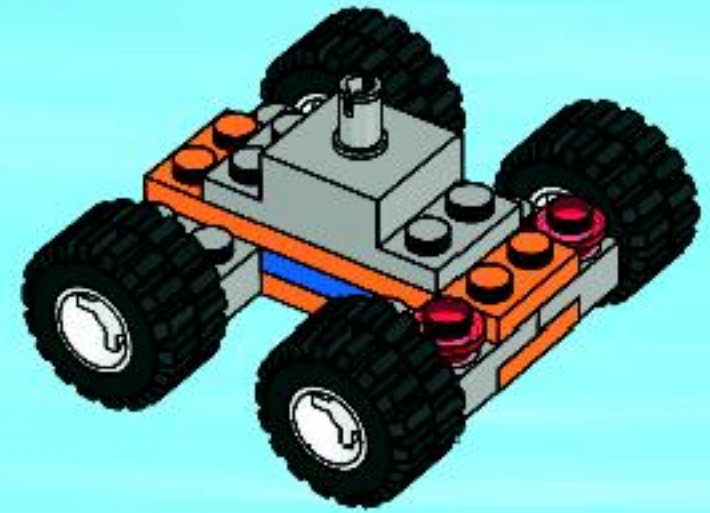

6

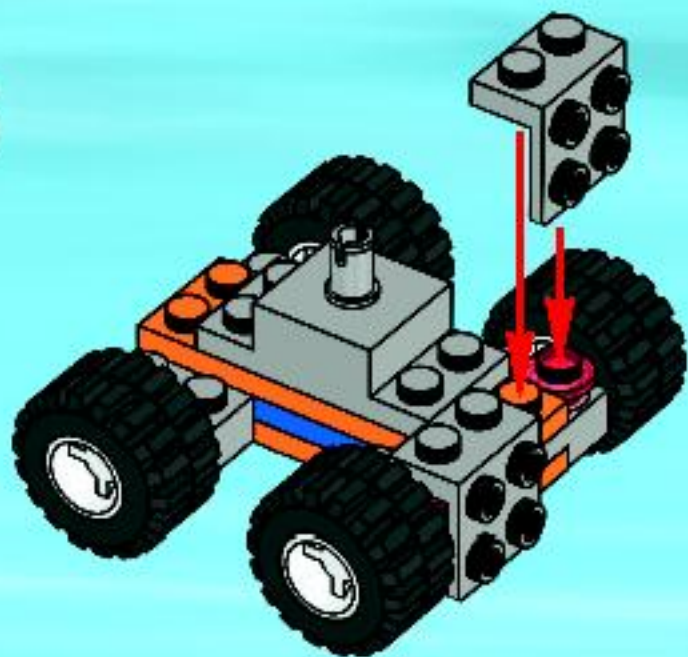

7

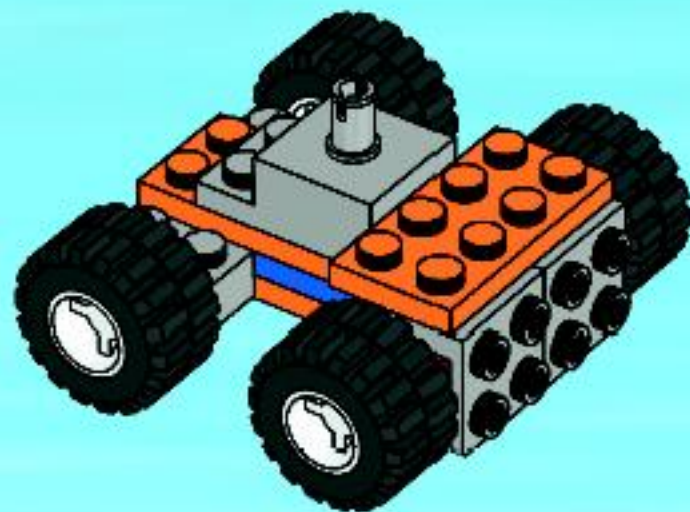

8

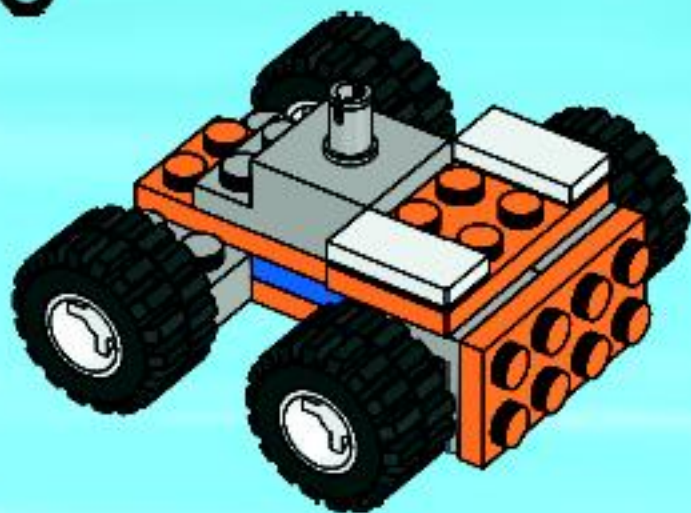

9

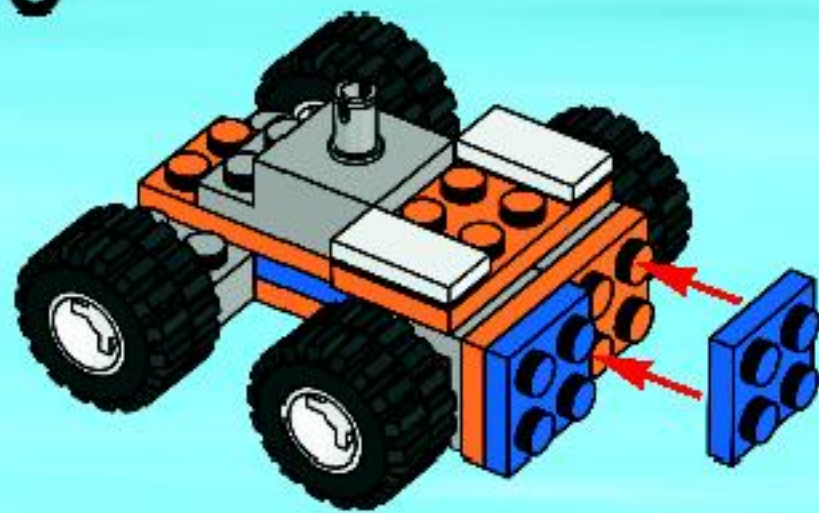

14

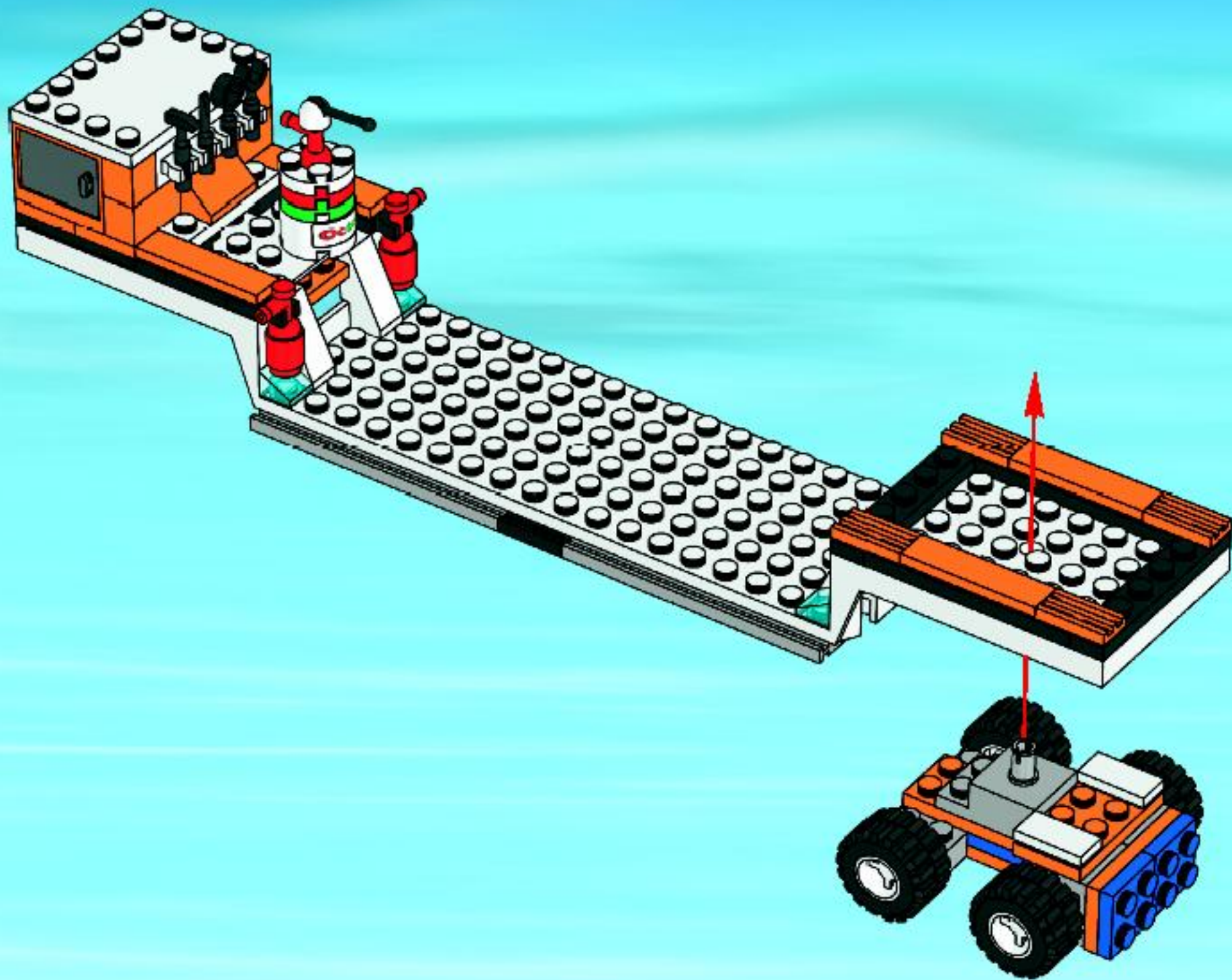



1



2



3

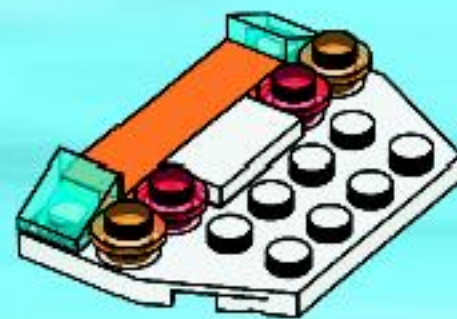

4

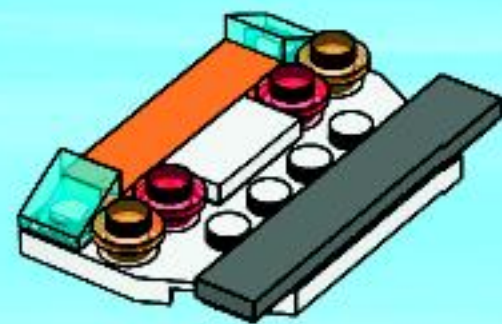

5



15

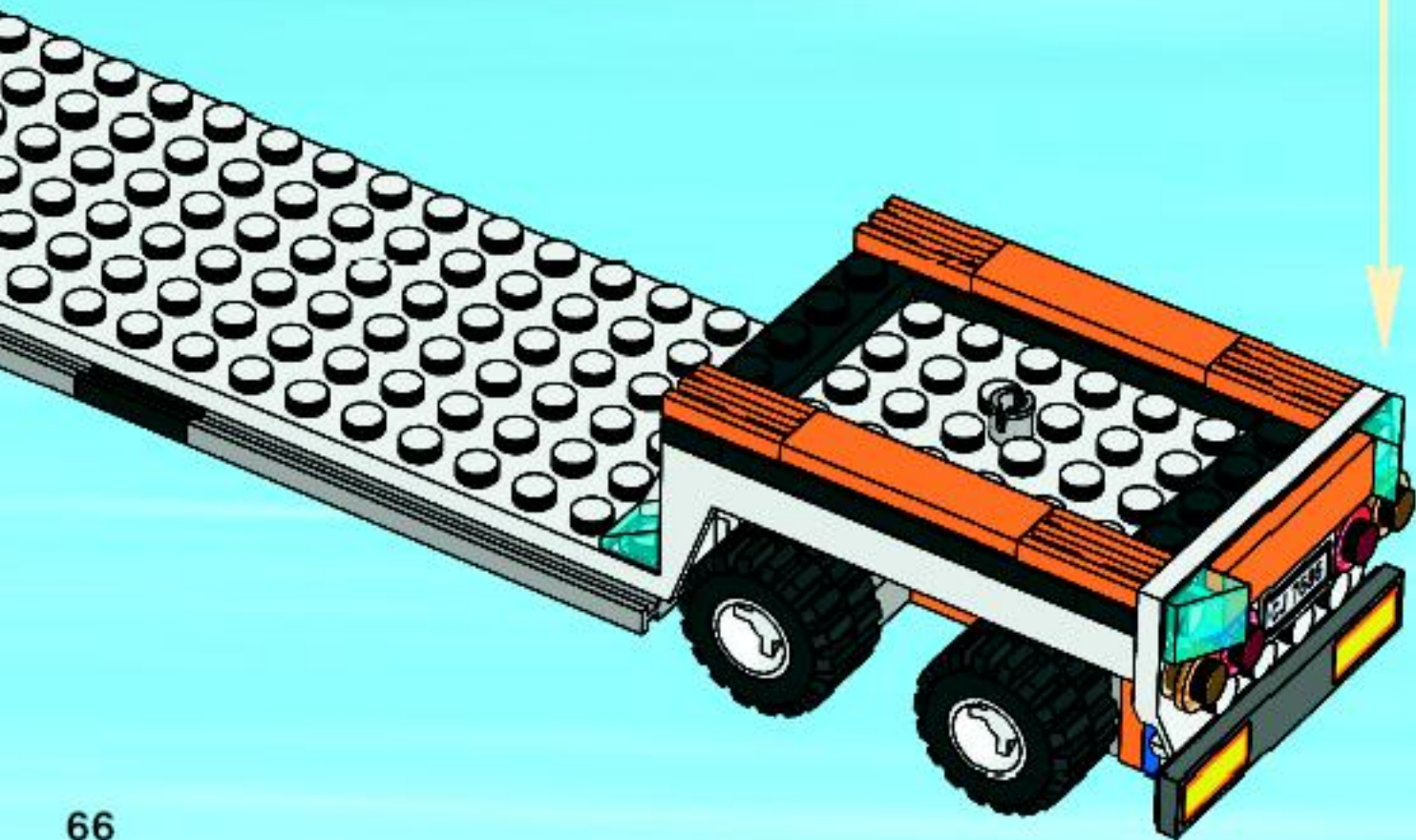

16





17



19

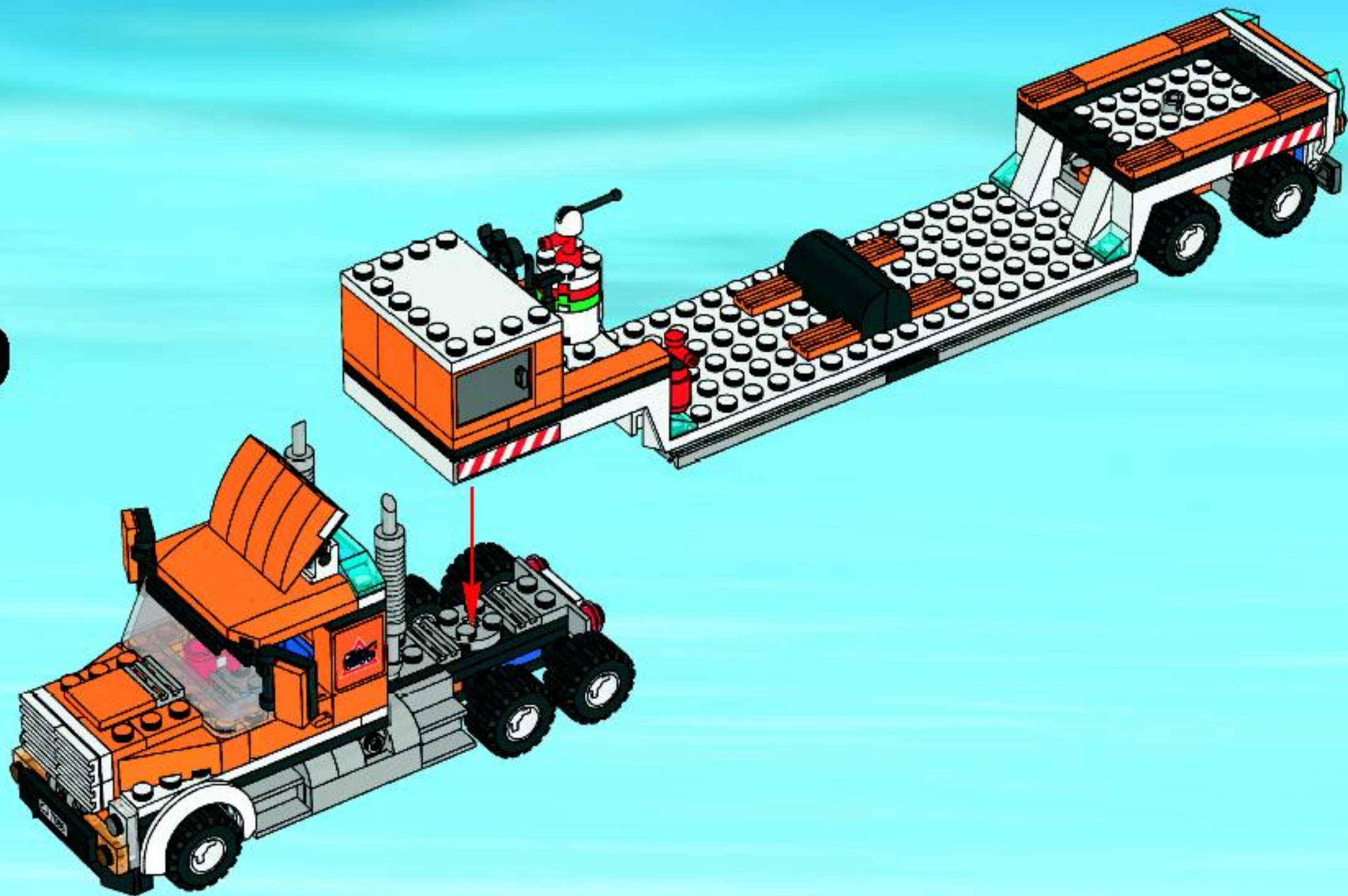

20



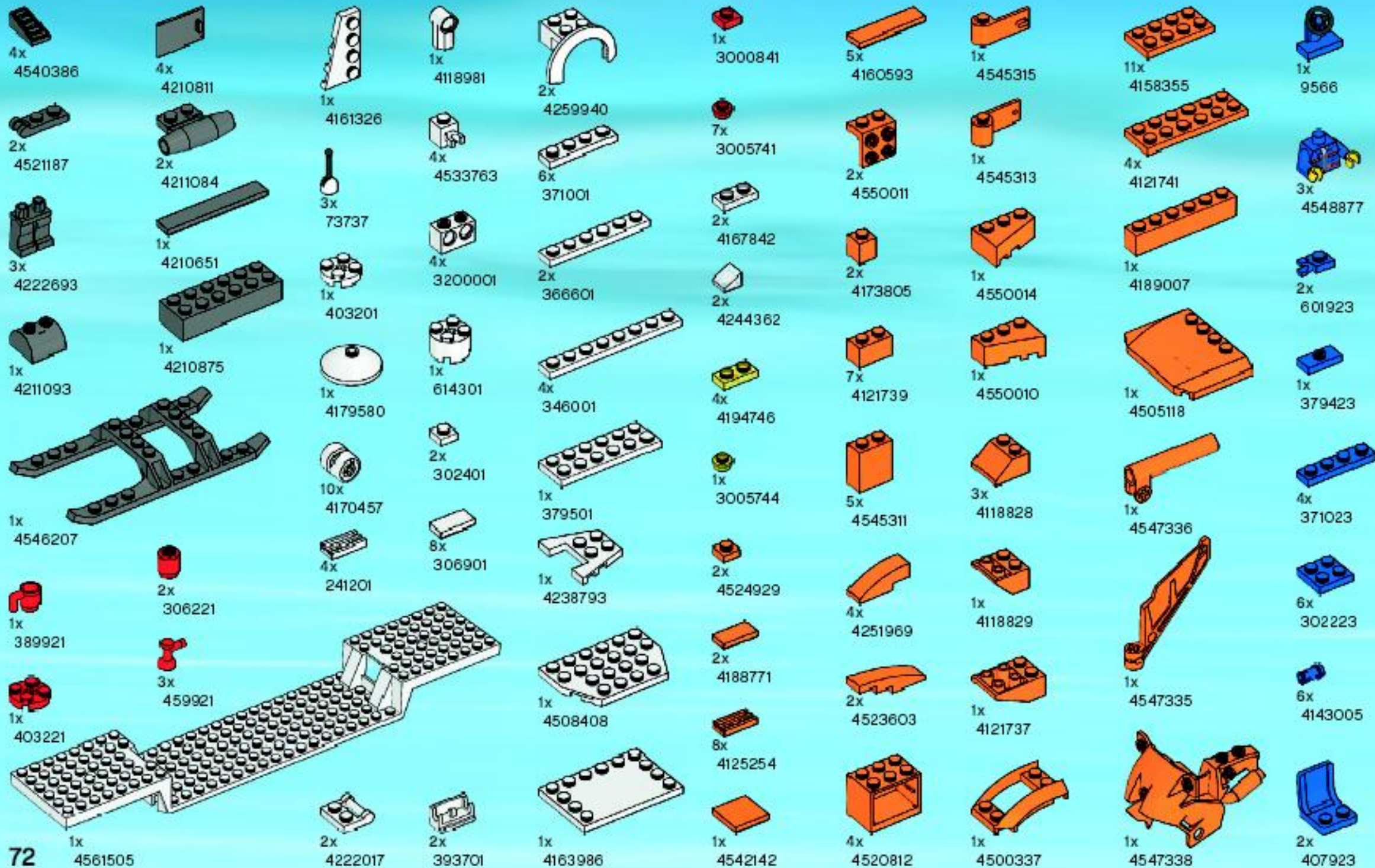



Customer Service

Kundenservice

Service Consommateurs

Servicio Al Consumidor

www.lego.com/service or dial



: 00800 5346 5555

: 1-800-422-5346

LEGO

CITY



7630



7631



7632



7633

FREE! GRATIS! GRATUIT!



club
MAGAZINE™

www.LEGOclub.com



00800 5346 5555*        

  **1-866-534-6258 • 1-877-518-5346**

US & Canada only

Canada seulement

* FreePhone. Mobile charges may apply. * Numéro sans Frais. Des Frais peuvent s'appliquer avec les téléphones cellulaires. * Get it for free! Kosten für Anrufe aus Mobilfunknetzen können anfallen. * Gratis telefonnummer vând vase lista. * Deber este gratis nummer, wir du ringer Pro Posttelefon. * Det är gratis, wir du ringer. Från en Post telefon.



VISIT THE WORLD'S
BIGGEST LEGO® SHOP!

www.LEGOshop.com



WIN LEGO® PRODUCTS

Fill out a survey and you might WIN a cool LEGO product
NO PURCHASE NECESSARY

Open to all residents where not prohibited

Go to www.nielsen.nm.dk/LEGO to fill out a survey for a chance to win a LEGO product.

WIN LEGO® PRODUCTEN

Vul een enquêteformulier in en maak kans op een cool LEGO® product
Kopen niet nodig

Iedereen uit landen waar geen enquêteverbod geldt mag deelnemen.
Ga naar www.nielsen.nl/m.dk/LEGO, vul een enquêteformulier in en maak kans op een LEGO product.

GEWINNE LEGO® PRODUKTE

Nimm an der Umfrage teil und GEWINNE ein tolles LEGO® Produkt!
Die Teilnahme am Gewinnspiel führt zu keinerlei Kaufverpflichtungen
Teilnahme in allen nicht ausgeschlossenen Ländern möglich
Wir verlosen unter allen Teilnehmern der Umfrage auf
www.nielsen.nl/m.dk/LEGO LEGO Produkte.

GAGNE DES PRODUITS LEGO®

Réponds à un questionnaire et tu pourrais GAGNER un produit LEGO® très cool !

Aucune obligation d'achat.

Ouvert à tous les résidents des pays autorisés.

Visite www.nielsen.nl/m.dk/LEGO pour répondre à un questionnaire et avoir une chance de gagner un produit LEGO.

レゴ®製品を「当てよう」

アンケートに記入して、かっこいいレゴ®製品を当てよう！
お買い上げの必要はありません。

禁止されていない限り、すべての皆様にご利用いただけます。
www.nielsen.nl/m.dk/LEGOにアクセスして、アンケートにご記入ください。当選者にはレゴ製品を差し上げます。

