



Disney · PIXAR  
**Toy**  
STORY



7592



1

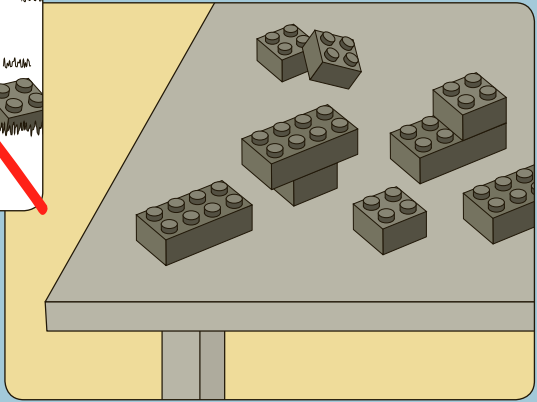
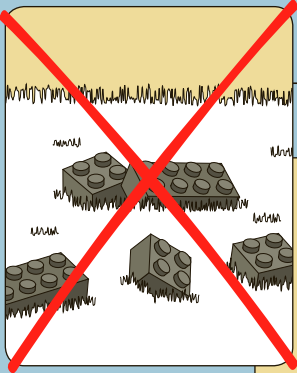

2





3





1x



1x

1



4x

2



1x



1x

3

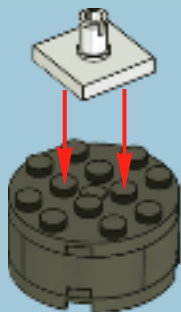

4



4x

4

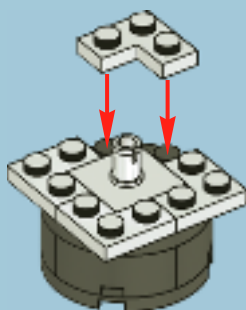

1x

5

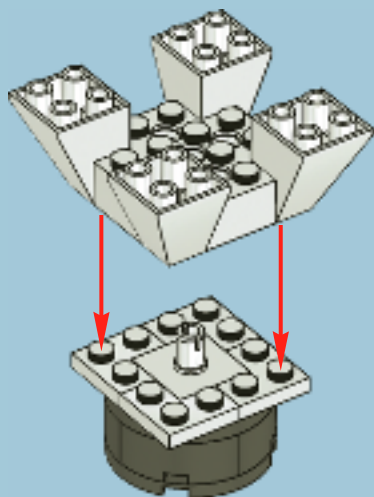



1x

# 6

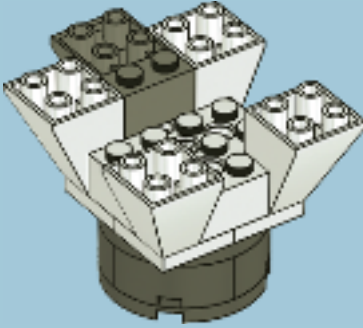

1x



1x



1x



1x

# 7

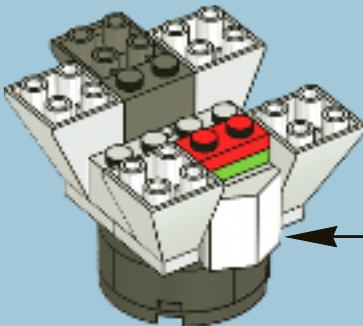

## 1

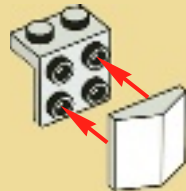

## 2



## 3

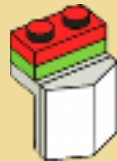

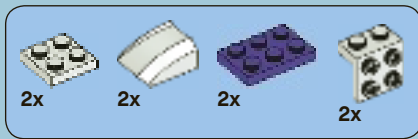

8

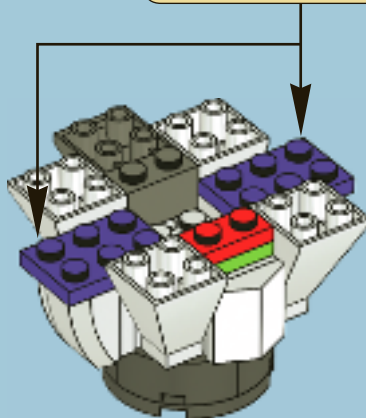
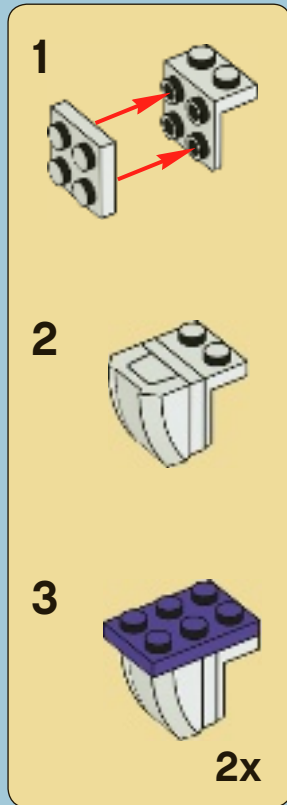



1x

# 9

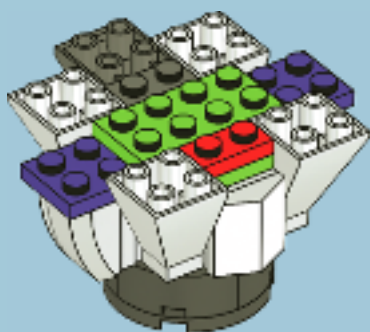

2x



1x

# 10

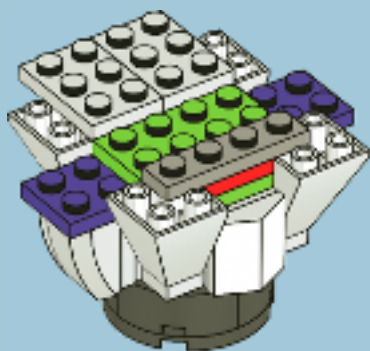





2x

# 11

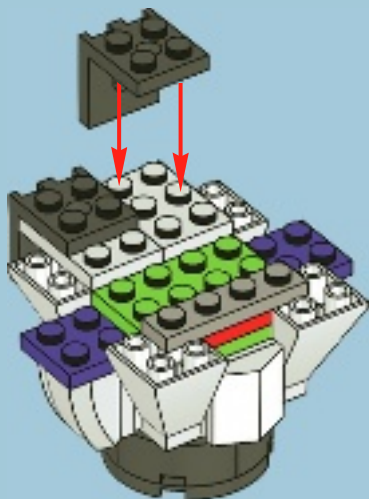

2x

# 12

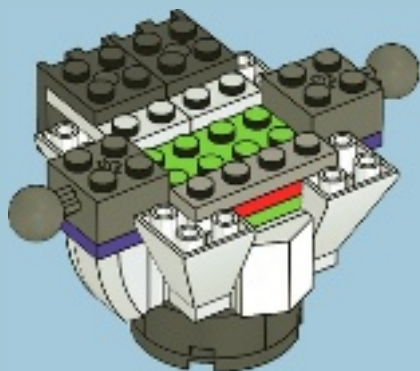



4x

# 13

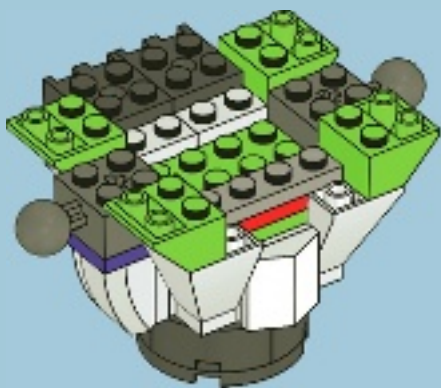

1x



2x

# 14

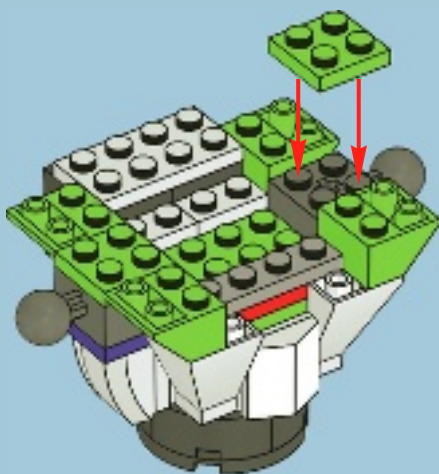



2x

# 15

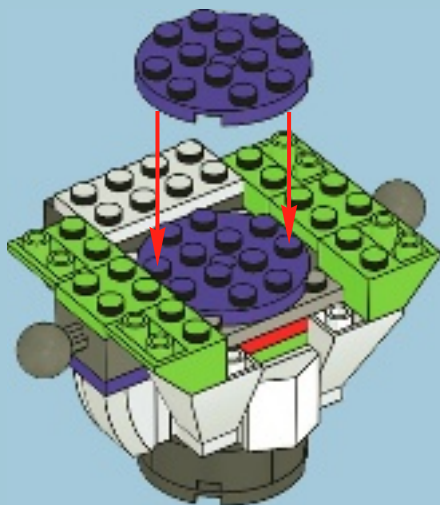

1x



1x

# 16

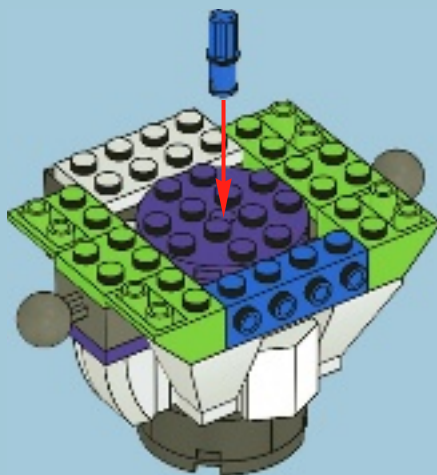

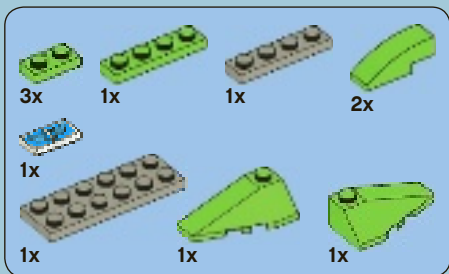

# 17

1

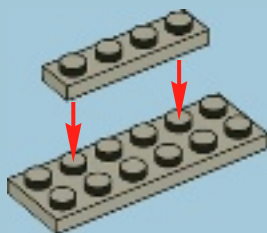

2

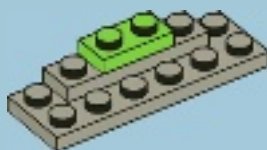

3

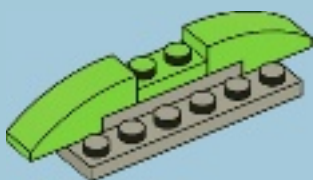

4

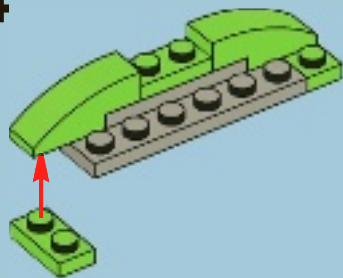

6

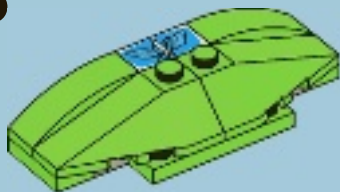

5

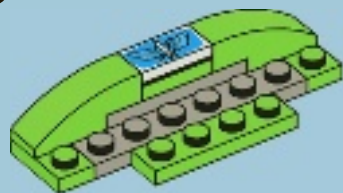

7

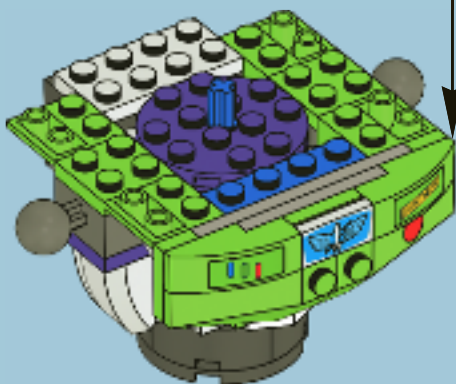
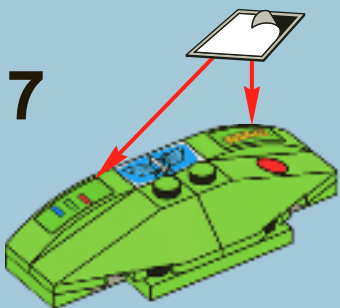

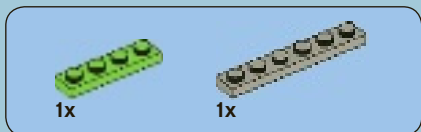

# 18

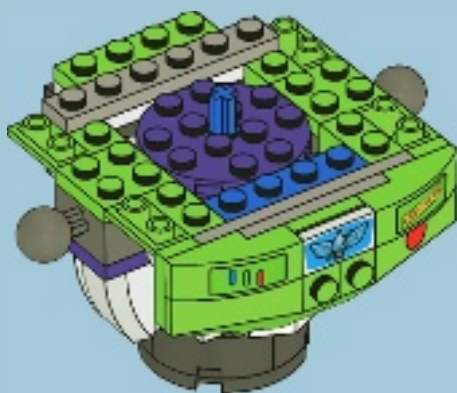

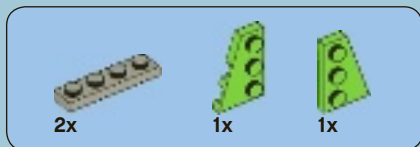

# 19

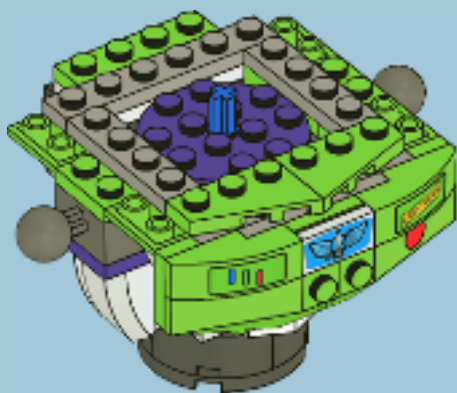

# 20

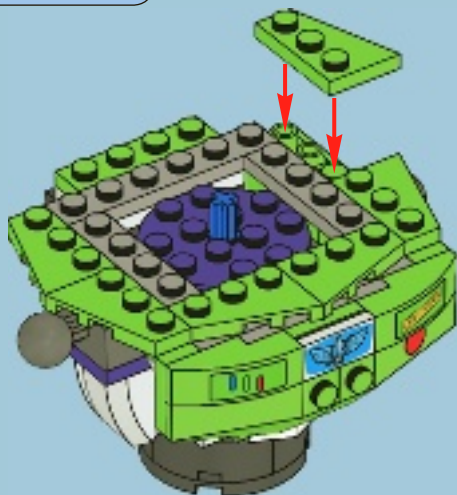



1x



2x

# 21

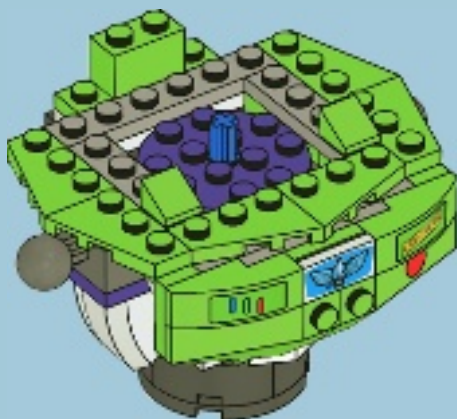

2x

# 22

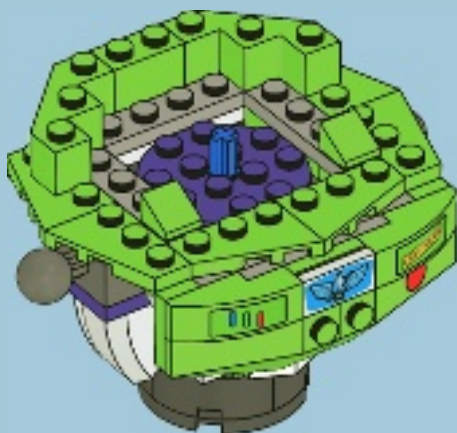



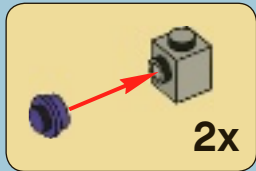
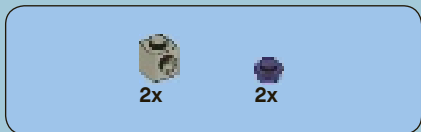

# 23

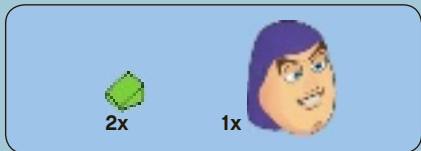
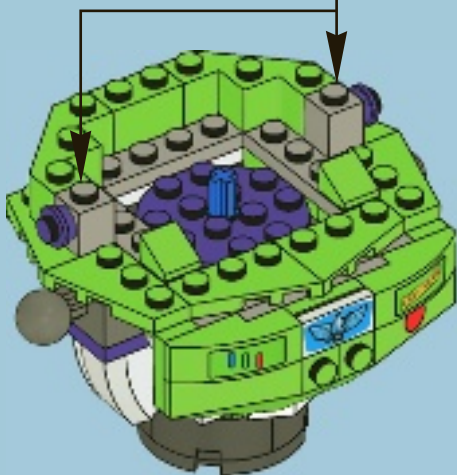

# 24



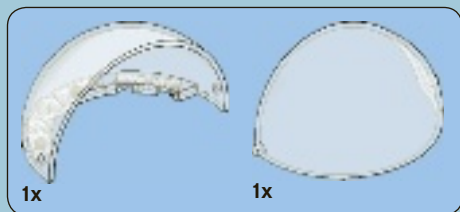

25

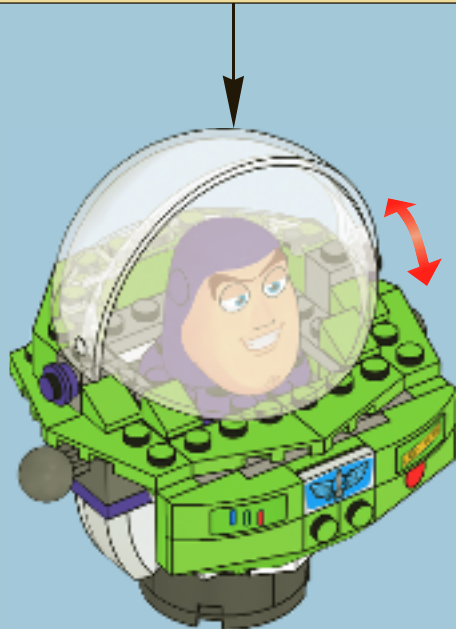
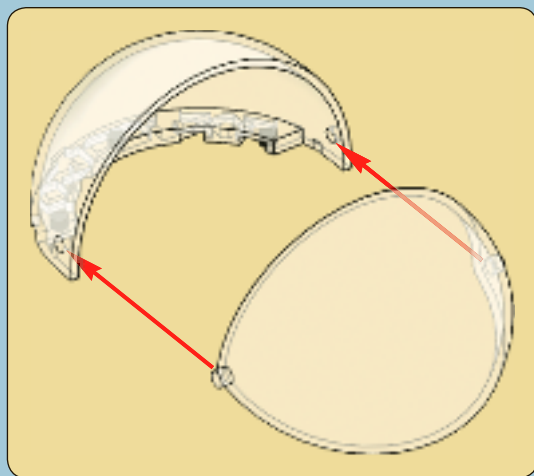

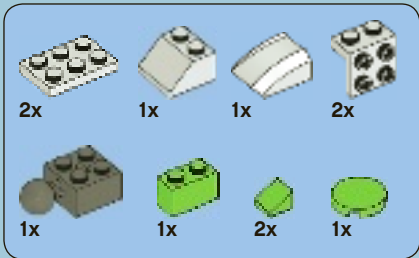
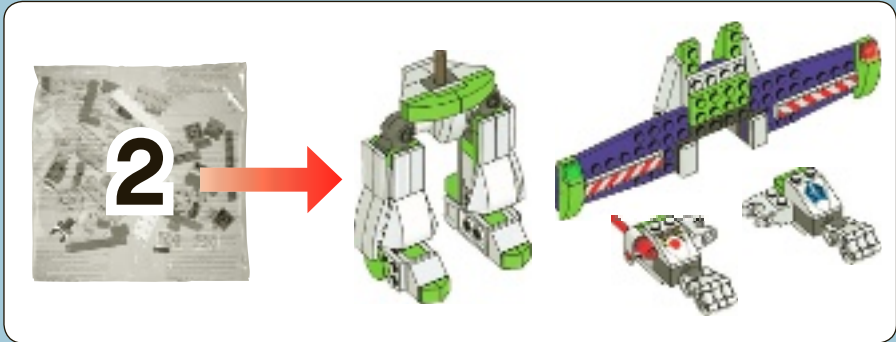

1



**2**

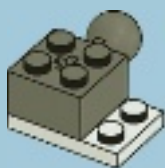

**3**

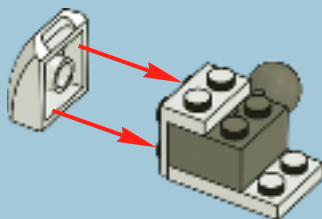

**4**





8

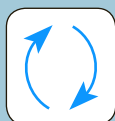

9

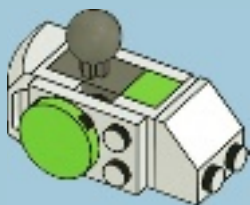

10

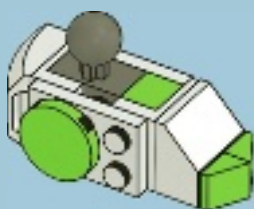

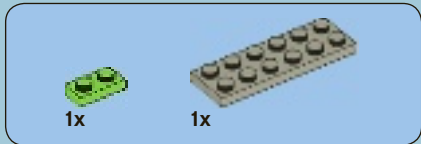

1

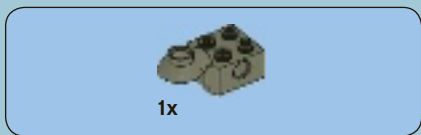

2

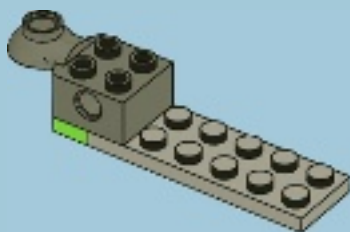



1x



1x

# 3

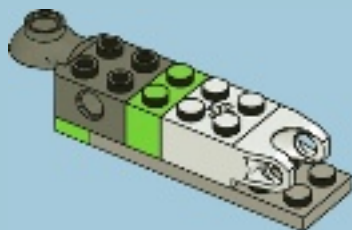

1x



1x

# 4

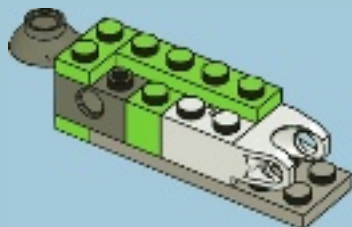





2x

5

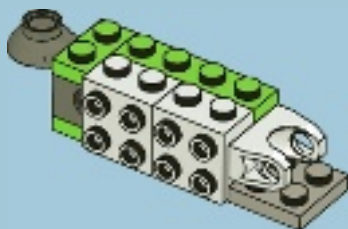

4x

6

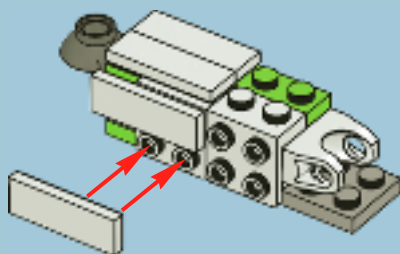

7

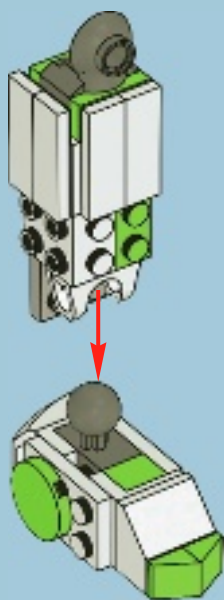



1x

8

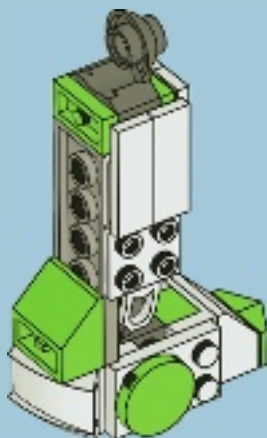

1x

9

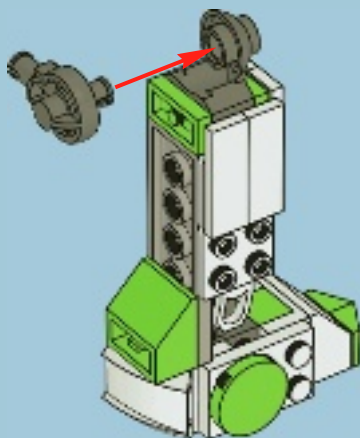



2x

# 10

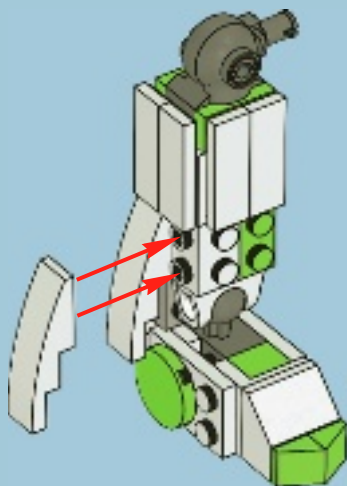
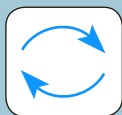

1x

# 11

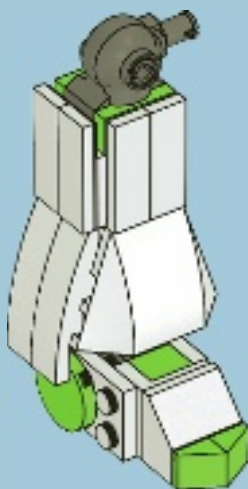



1x

1



2x

2

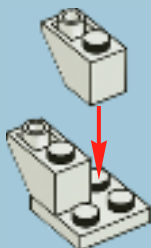



2x

# 3

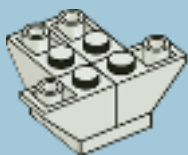

1x



1x



1x

# 4

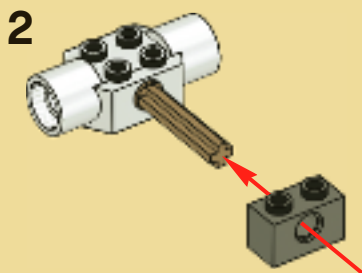
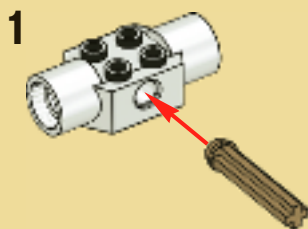



2x

5

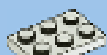
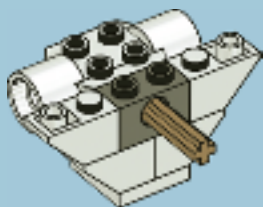

1x



2x

6

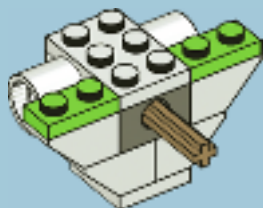



1x



1x

7

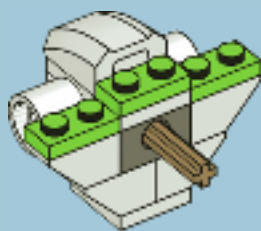

2x

8

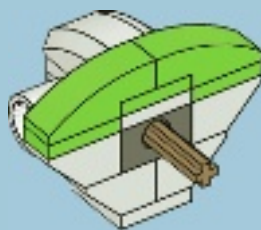



9

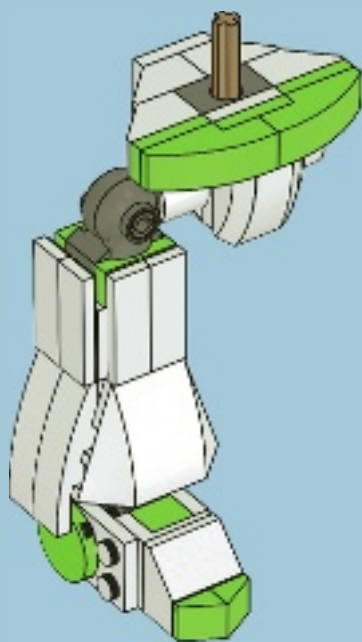



1



2



**3**

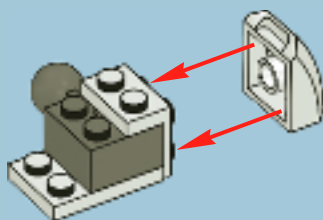

**4**



5

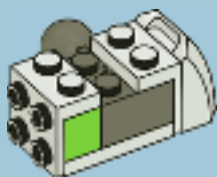

6

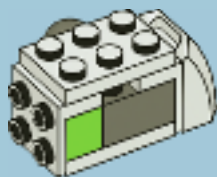

7



8

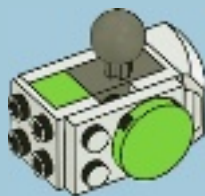

9

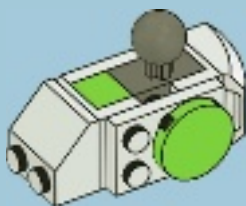

10

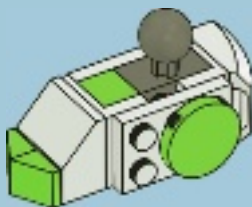



1x



1x

# 1

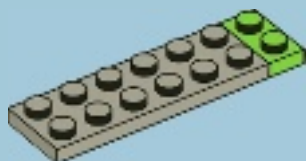

1x

# 2

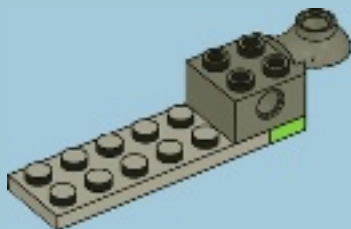



1x



1x

# 3



1x



1x

# 4

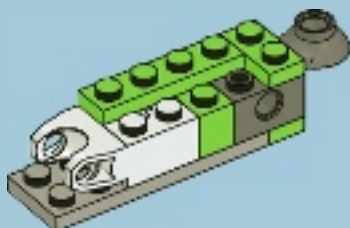



2x

5

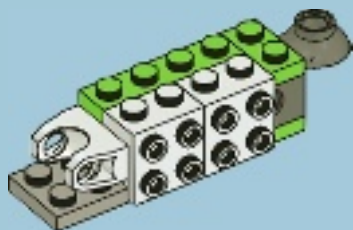

4x

6

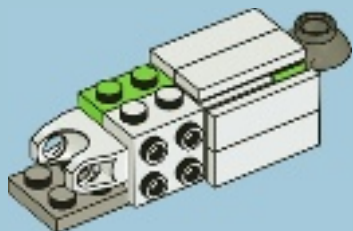



7

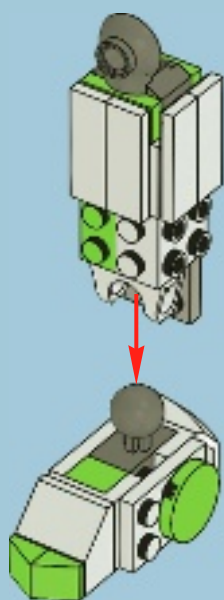



1x

8

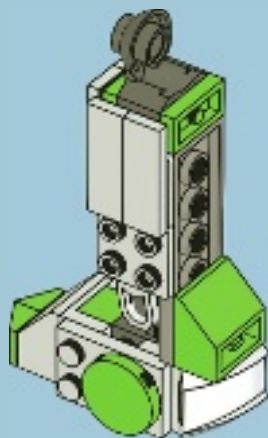

1x

9

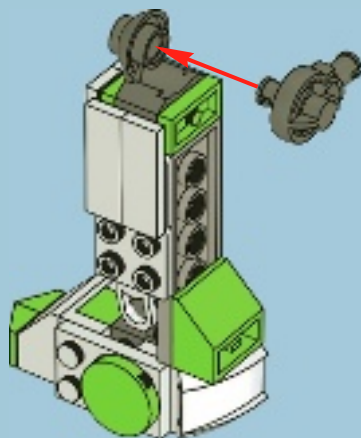



2x

# 10

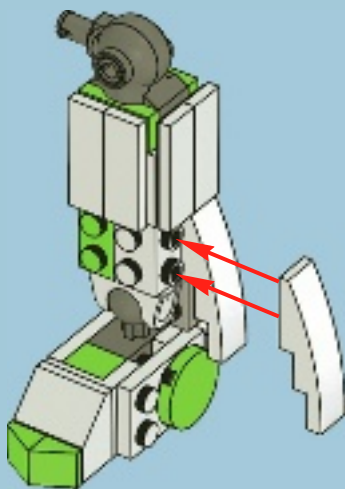

1x

# 11

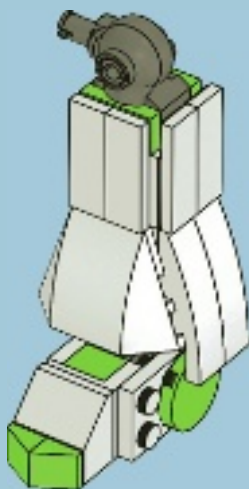

12

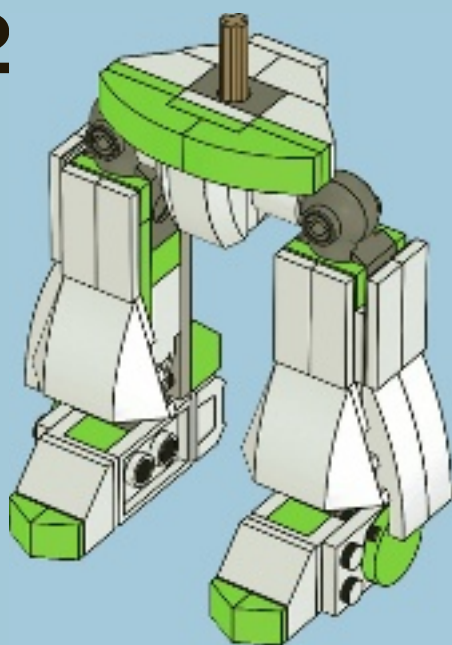

13

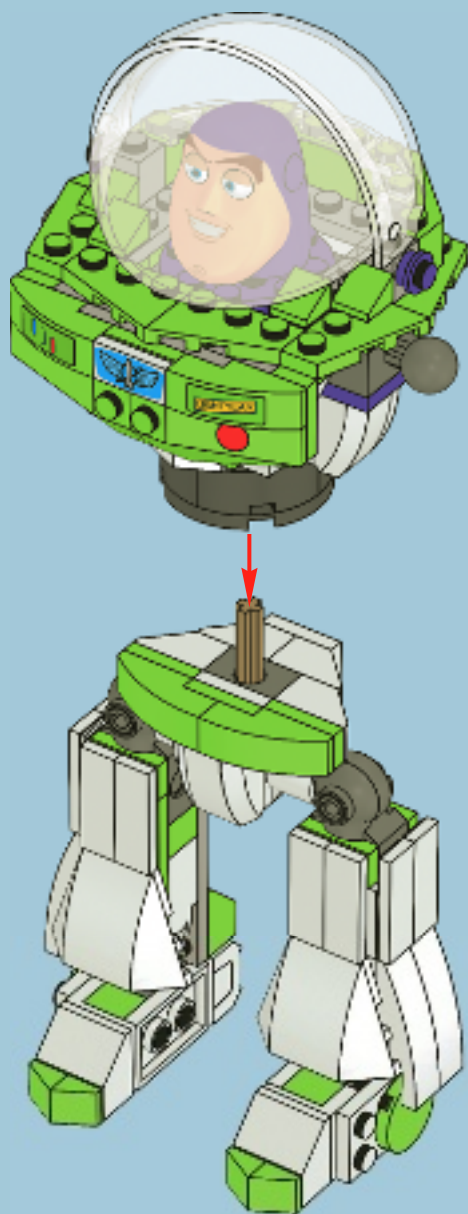



1x



1x



1x



1x



1x



2x



1x



1x

# 14

## 1



## 2

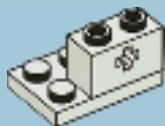

3

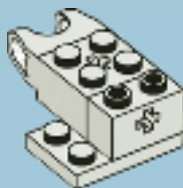

4



5



6

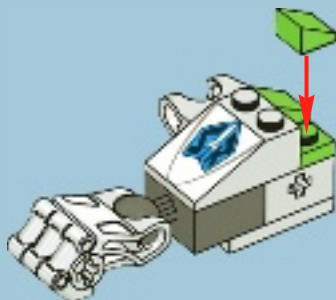

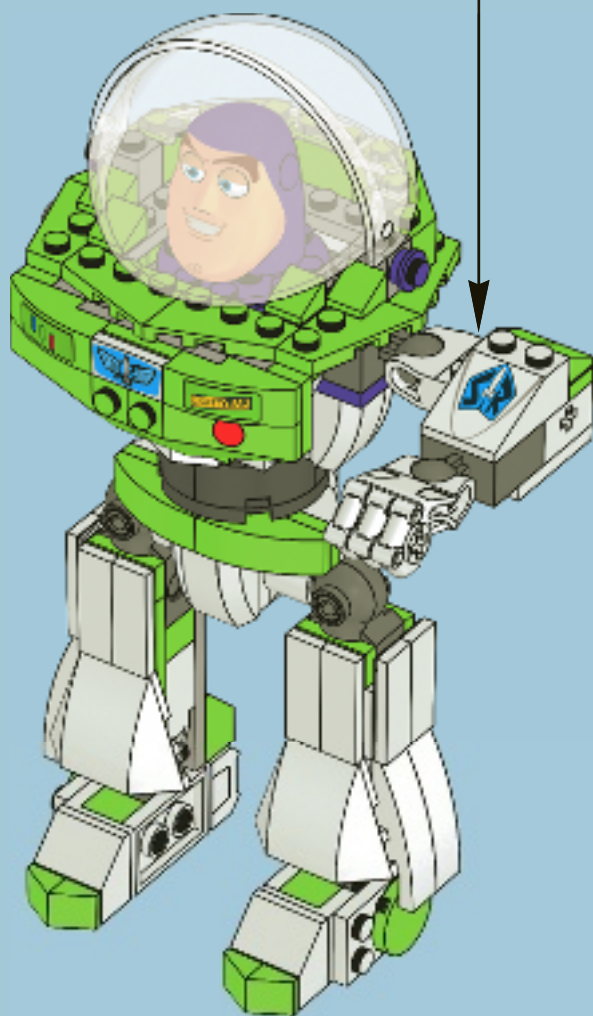





1x



2x



1x



1x



1x



1x



1x



1x



1x



1x

# 15

1

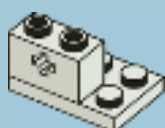

2



3



4

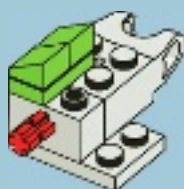

5

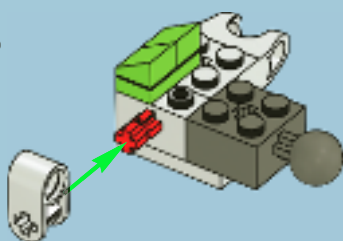

6



7

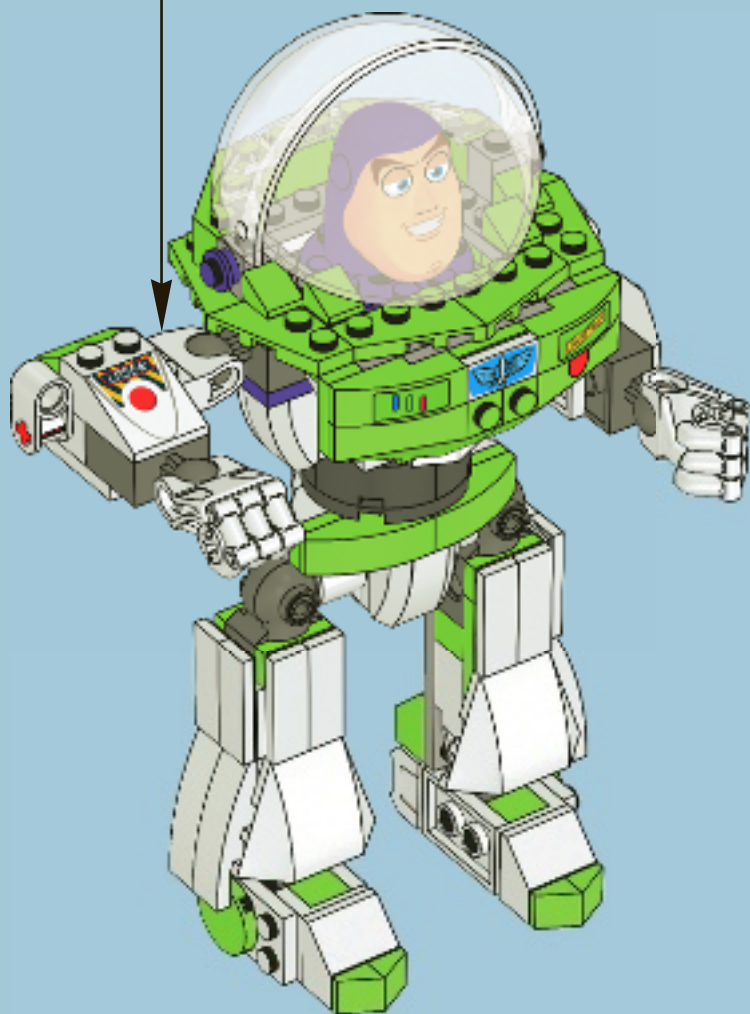
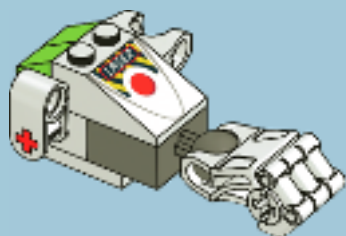



1x



1x

# 16

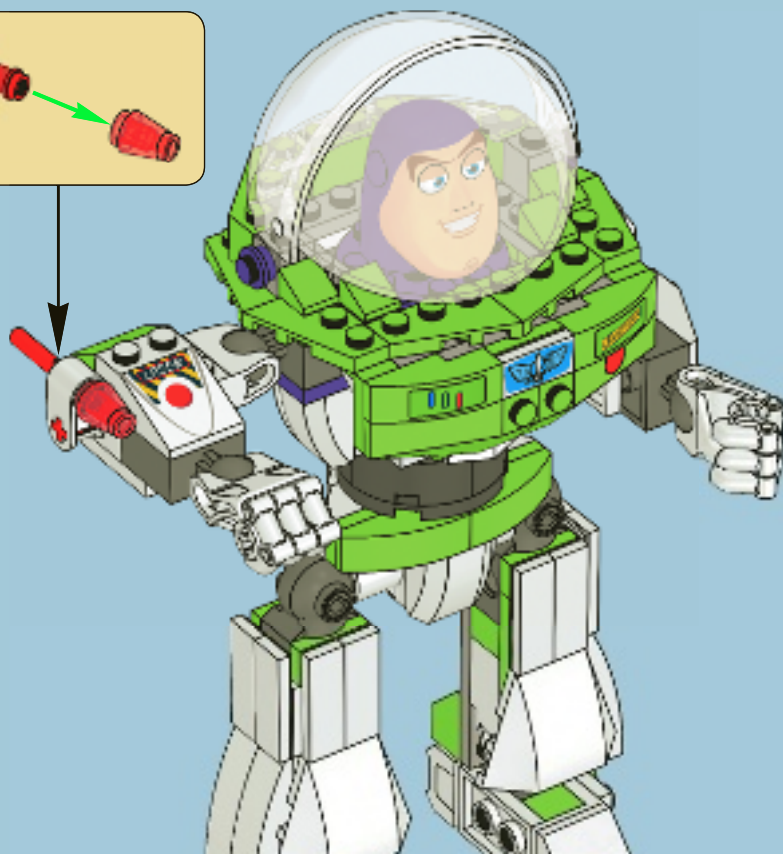
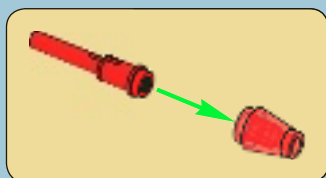



**1**



**2**





1x



2x

3

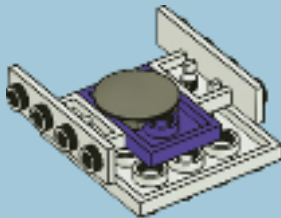

2x

4

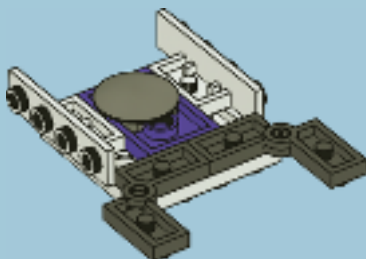

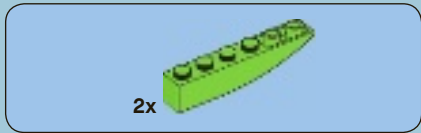

5

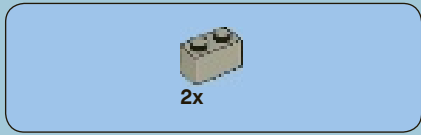
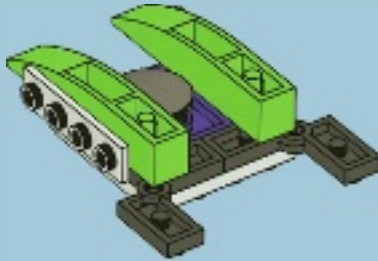

6

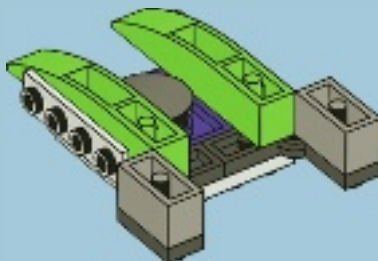



2x

7

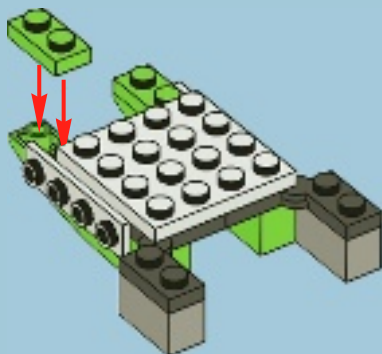

2x

8

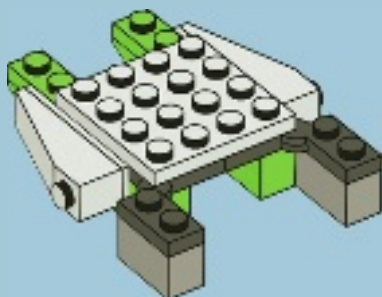



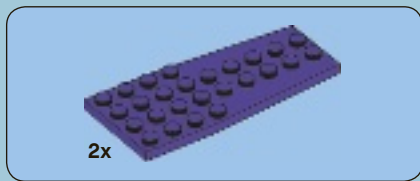

9

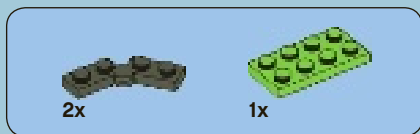
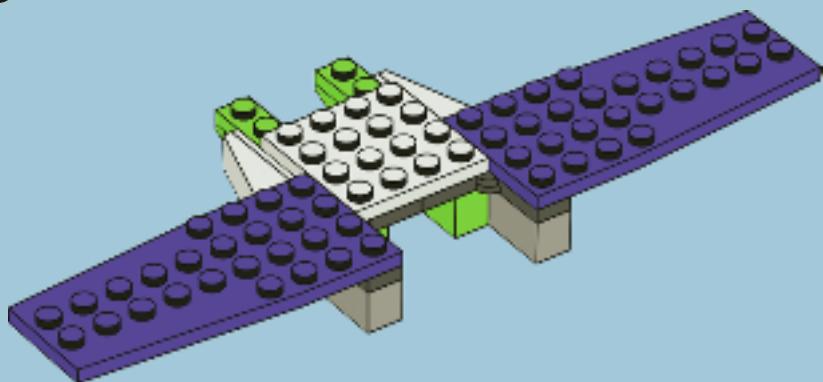

10

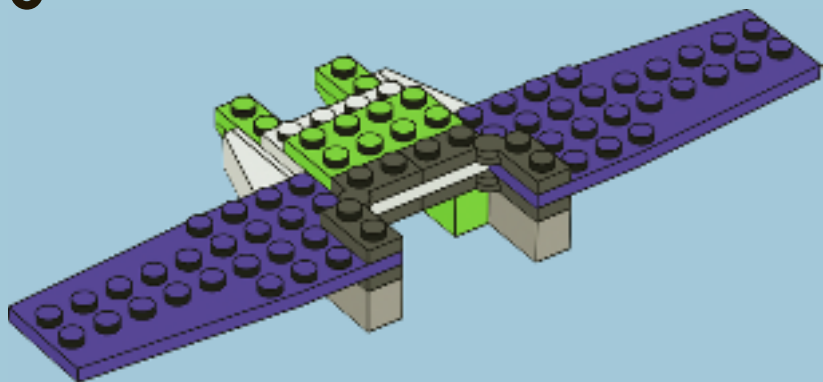

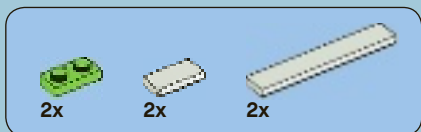

11

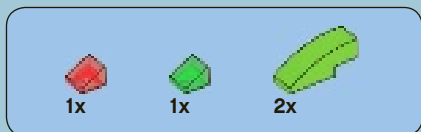
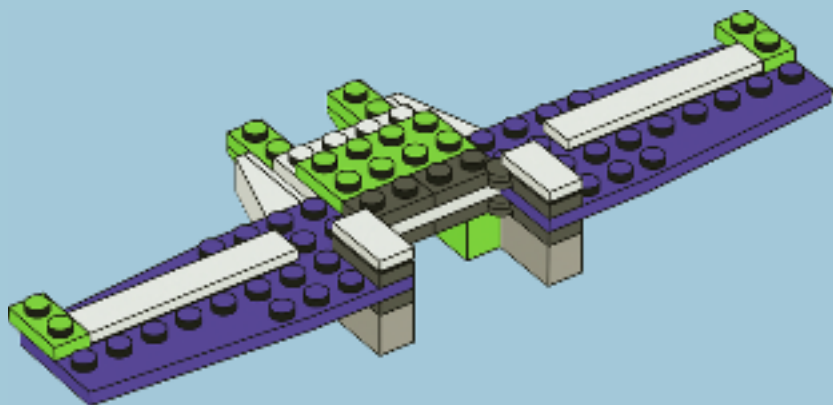

12

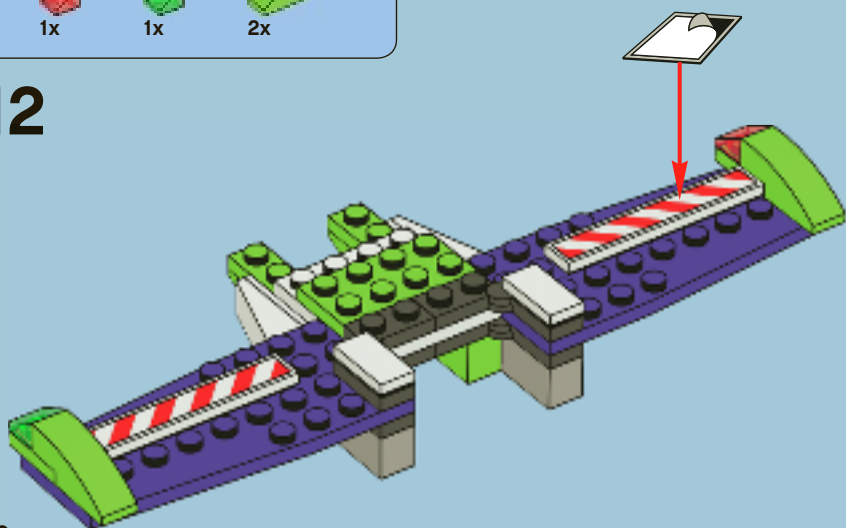

13

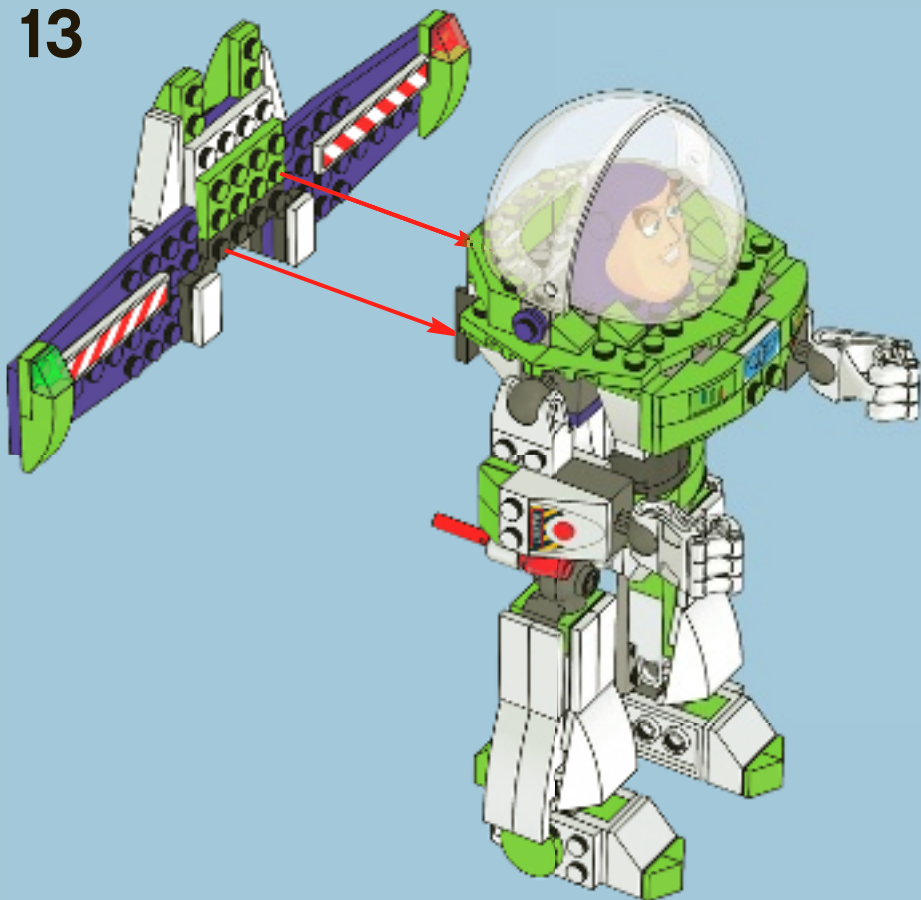



Disney · PIXAR  
**TOY**  
STORY

**7590**



**7594**



**7593**



**7595**



LEGO and the LEGO logo are trademarks of the LEGO group.  
©2010 The LEGO group.  
© Disney/Pixar.







2x  
4233486



4x  
4578559



1x  
4218492



6x  
366501



2x  
303901



1x  
4578606



1x  
4578561



1x  
4578562



4x  
4518992



2x  
4567878



5x  
4195869



1x  
4173670



1x  
4578563



2x  
306901



8x  
4558168



2x  
663601



3x  
302201



9x  
302101



1x  
302001



1x  
4243812



11x  
4615649



2x  
4282737



2x  
4539157



2x  
4515359



1x  
4565969



1x  
4212411



1x  
4543857



1x  
4206482



4x  
4567436



2x  
395626



4x  
74011



2x  
4515350



1x  
4526119



1x  
4142865



1x  
614321



1x  
302321



5x  
4164022



2x  
4568657



12x  
4504372



6x  
4529679



1x  
4568655



1x  
4568654



6x  
4537928



2x  
4578749



17x  
4164037



2x  
4537937



4x  
4187743



2x  
4537936



3x  
4539907



3x  
4539908



2x  
4541957



1x  
4563687



1x  
4566927



2x  
4211388



2x  
4558953



4x  
4211445



1x  
4211438



3x  
4211452



2x  
4568656



3x  
4225142



2x  
4568772



2x  
4566522



1x  
4566101



1x  
4544720



1x  
4244363



1x  
4244573



6x  
4497253



2x  
4227395



1x  
4211111



1x  
4211064



1x  
4278274



2x  
4522784



1x  
246001



4x  
242001



1x  
4578724



1x  
4566183



1x  
4566184



## Customer Service

Kundenservice

Service Consommateurs

Servicio Al Consumidor

[www.lego.com/service](http://www.lego.com/service) or dial



00800 5346 5555 :

1-800-422-5346 :



**FREE! GRATIS! GRATUIT!**

**LEGO**

**club**  
MAGAZINE™

**www.LEGOclub.com**



**00800 5346 5555\***



**1-866-534-6258 • 1-877-518-5346**

UK & Canada only

Canada seulement

\* Freephone. Mobile charges may apply. \* Numéro sans Frais. Des Frais peuvent s'appliquer avec les téléphones cellulaires.  
\* Gebührenfrei, Kosten für Anrufer aus Mobilfunknetzen können abweichen. \* Gratis telefoonnummer vanaf vaste lijn.  
\* Det er ett gratis nummer, när du ringer Fra Fasttelefon. \* Det är gratis, när du ringer Från en Fast telefon.



**VISIT THE WORLD'S  
BIGGEST LEGO® SHOP!**

**www.LEGOshop.com**



# WIN!

Go to [www.nielsen.com/LEGO](http://www.nielsen.com/LEGO)  
to fill out a survey for a chance  
to win a cool LEGO® Product.

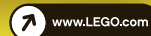

No purchase necessary.  
Open to all residents where not prohibited.



## [www.nielsen.com/LEGO](http://www.nielsen.com/LEGO)

### GEWINNE!

Nimm an der Umfrage auf  
[www.nielsen.com/](http://www.nielsen.com/)  
LEGO teil und hab die Chance ein cooles  
LEGO Produkt zu gewinnen!

Die Teilnahme am Gewinnspiel führt zu keinerlei  
Kaufverpflichtungen. Teilnahme in allen nicht  
ausgeschlossenen Ländern möglich.

### WIN!

Ga naar [www.nielsen.com/LEGO](http://www.nielsen.com/LEGO),  
vul een enquêteformulier in en  
maak kans op een  
cool LEGO® product.

Geen aankoopverplichting.  
Iedereen mag deelnemen, uitgezonderd  
ingezetenden  
van landen waar een enquêteverbod geldt.

### GAGNE!

Visite [www.nielsen.com/LEGO](http://www.nielsen.com/LEGO)  
pour répondre à un questionnaire  
et avoir une chance de gagner  
un produit LEGO® très cool!

Aucune obligation d'achat.  
Ouvert à tous les résidents des pays  
autorisés.

### 当てよう!

[www.nielsen.com/LEGO](http://www.nielsen.com/LEGO)  
にアクセスして、  
アンケートにご記入ください。  
当選者にはレゴ®製品を  
差し上げます。

お買い上げの必要はありません。  
禁止されていない限り、すべての皆様にご利用いただけます。