



PRINCE OF  
**PERSIA**  
THE SANDS OF TIME



7571



**WARNING: CHOKING HAZARD.**  
Toy contains small parts and a small ball.  
Not for children under 3 years.



1

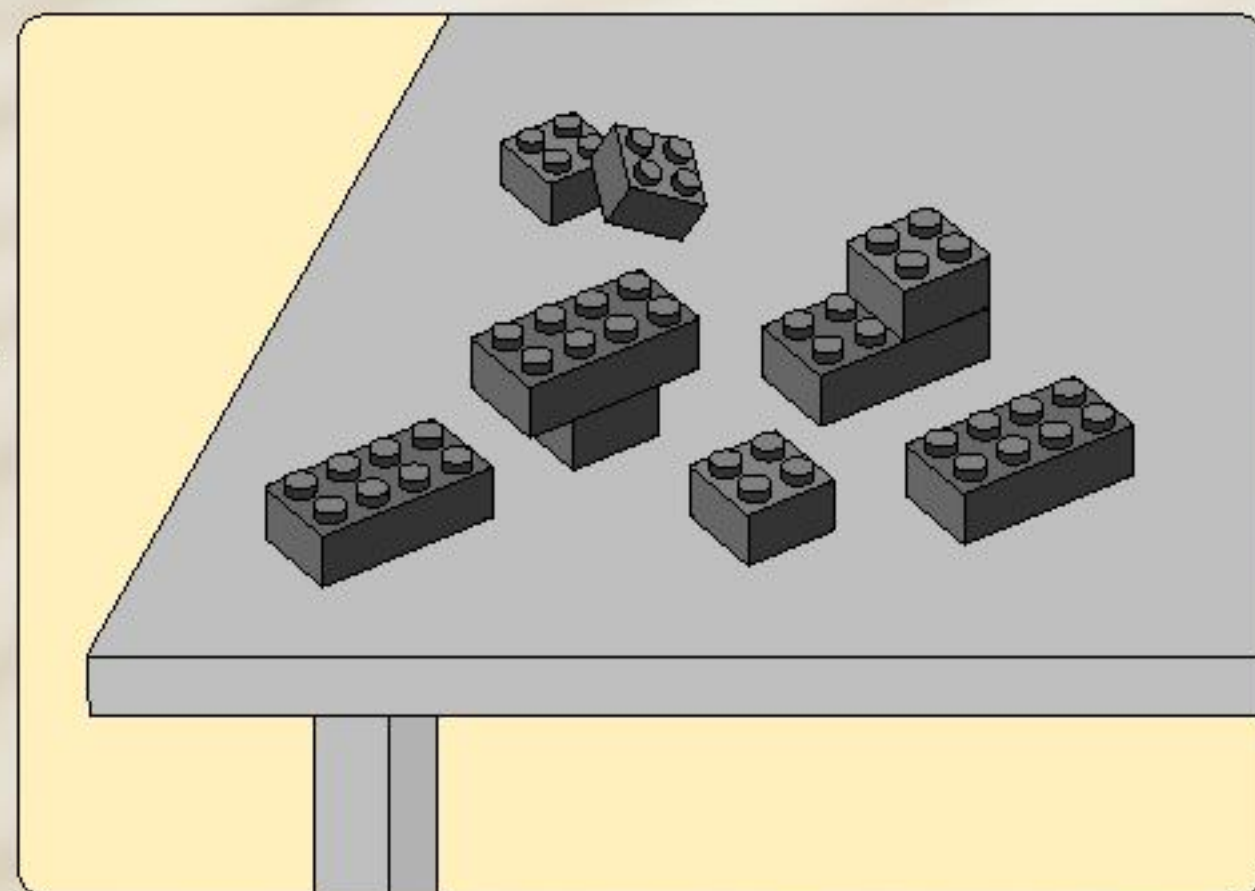
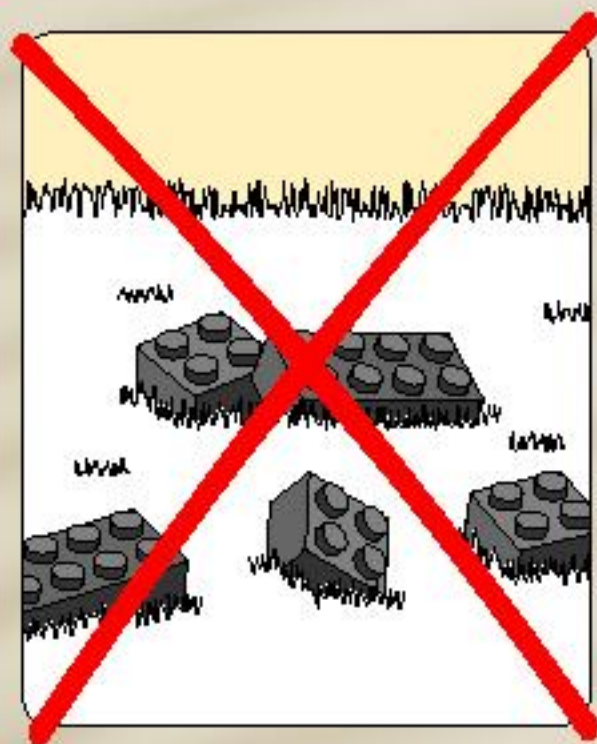

2

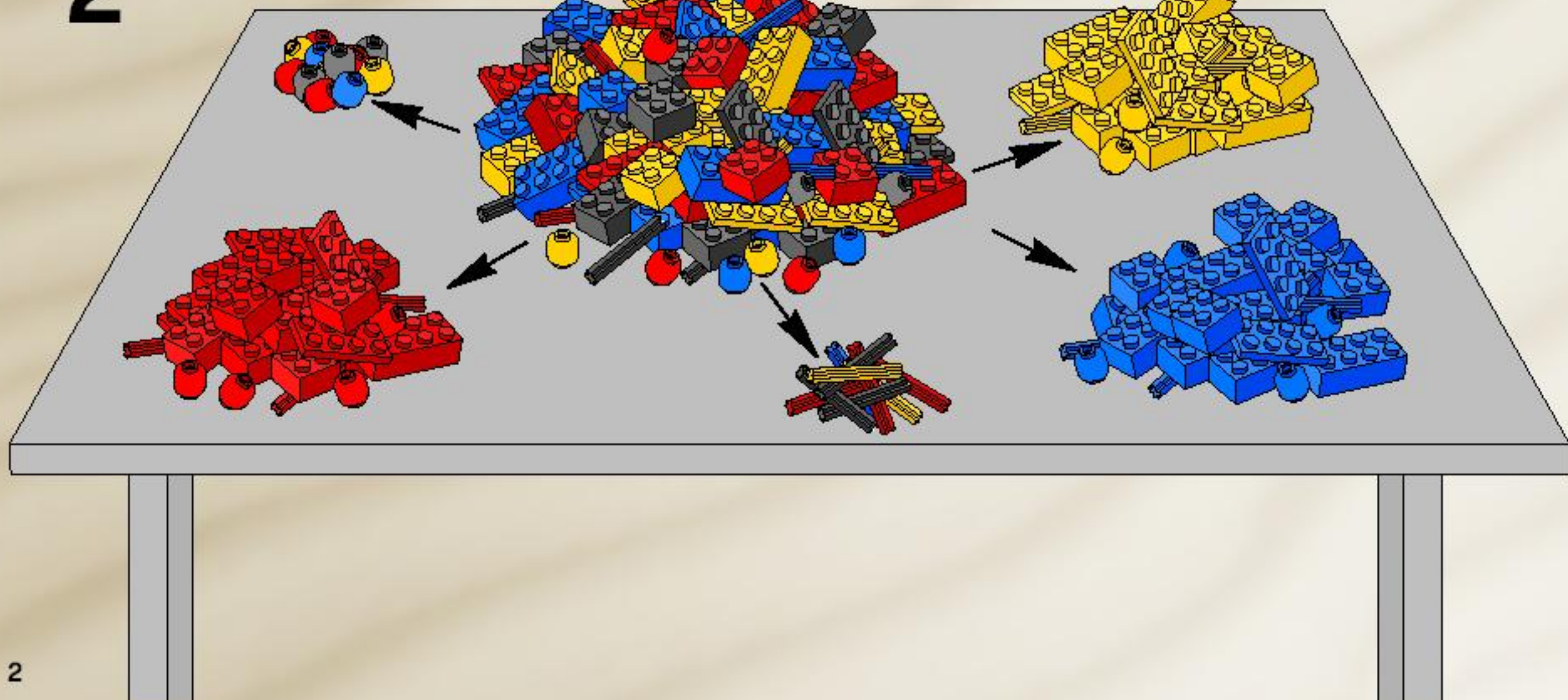



# 3

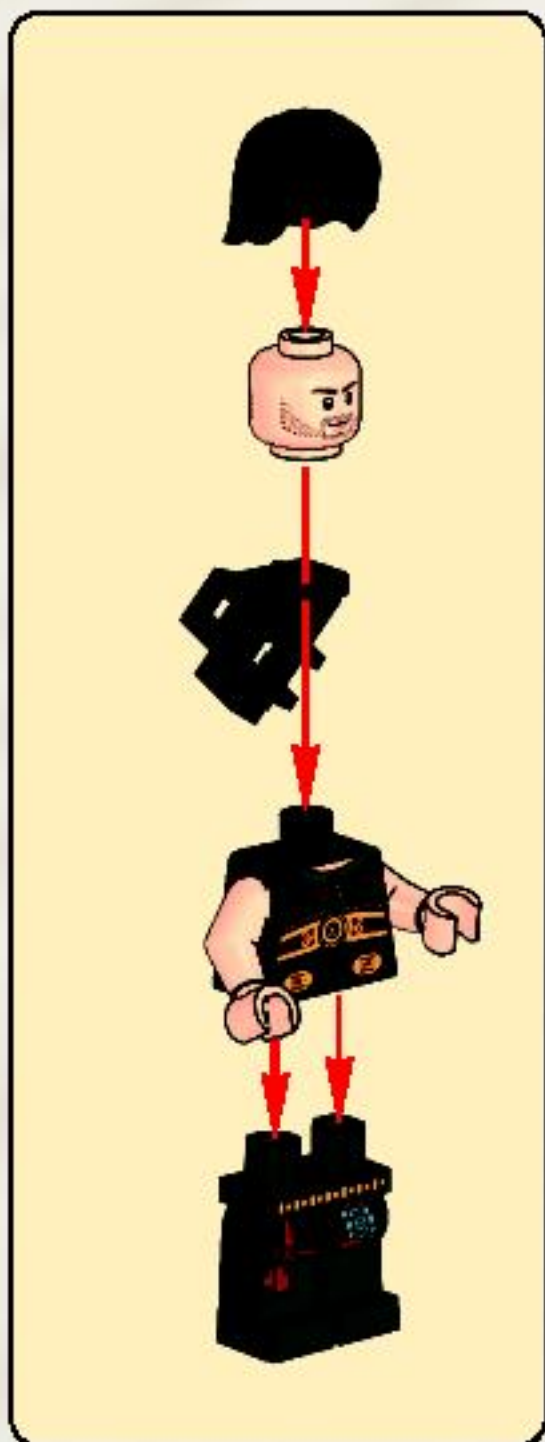

**AVERTISSEMENT : RISQUE D'ÉTOUFFEMENT.**  
Le jouet contient des petites pièces ainsi qu'une petite boule.  
Il ne convient pas aux enfants de moins de 3 ans.



**ADVERTENCIA: PELIGRO DE ASFIXIA.**  
Juguete que contiene partes pequeñas y una pelota pequeña.  
No recomendado para niños menores de 3 años.

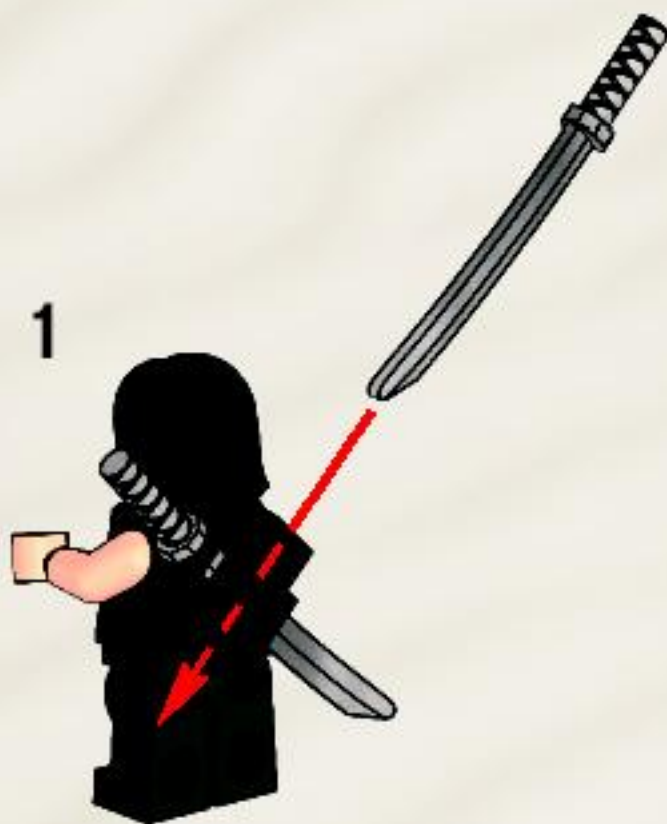

2



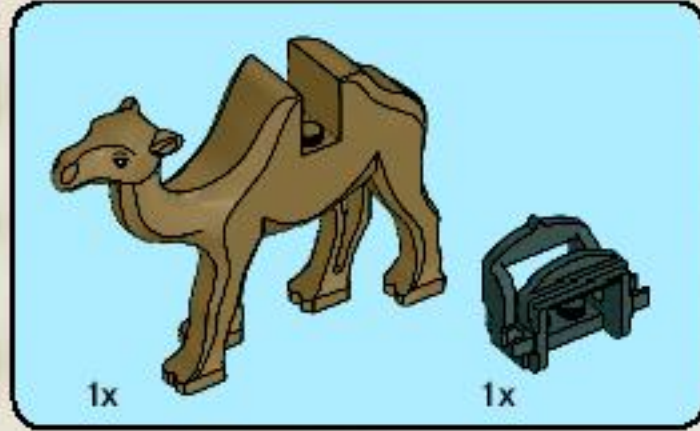
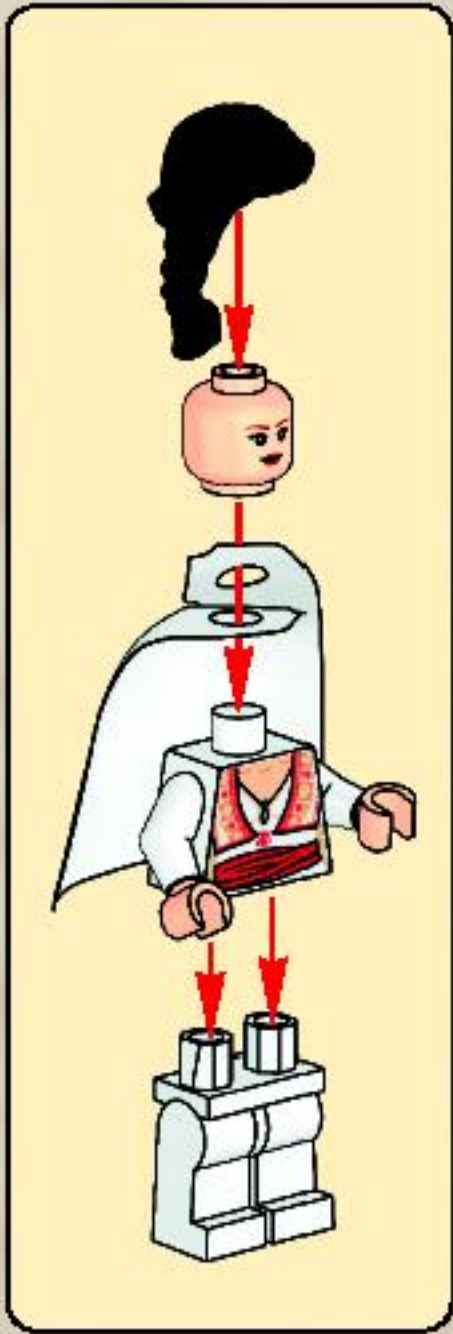

1

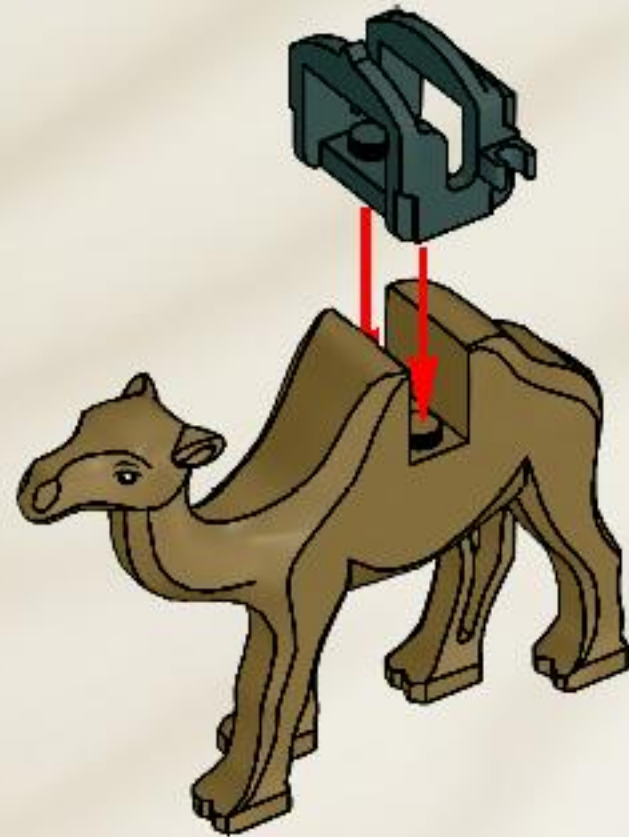



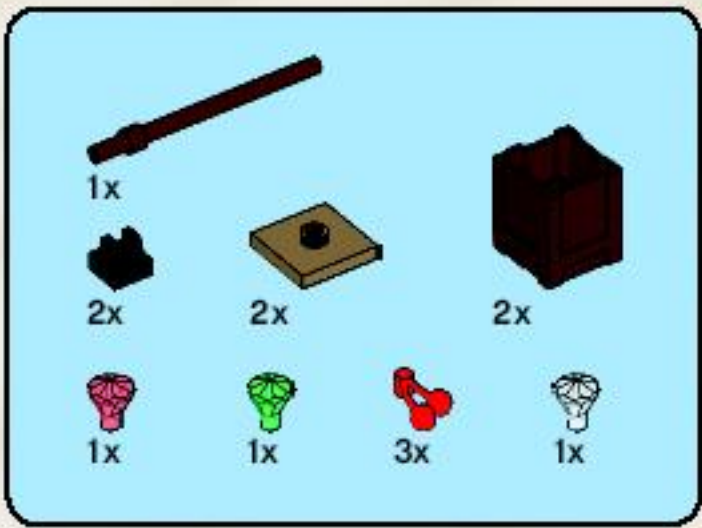

2

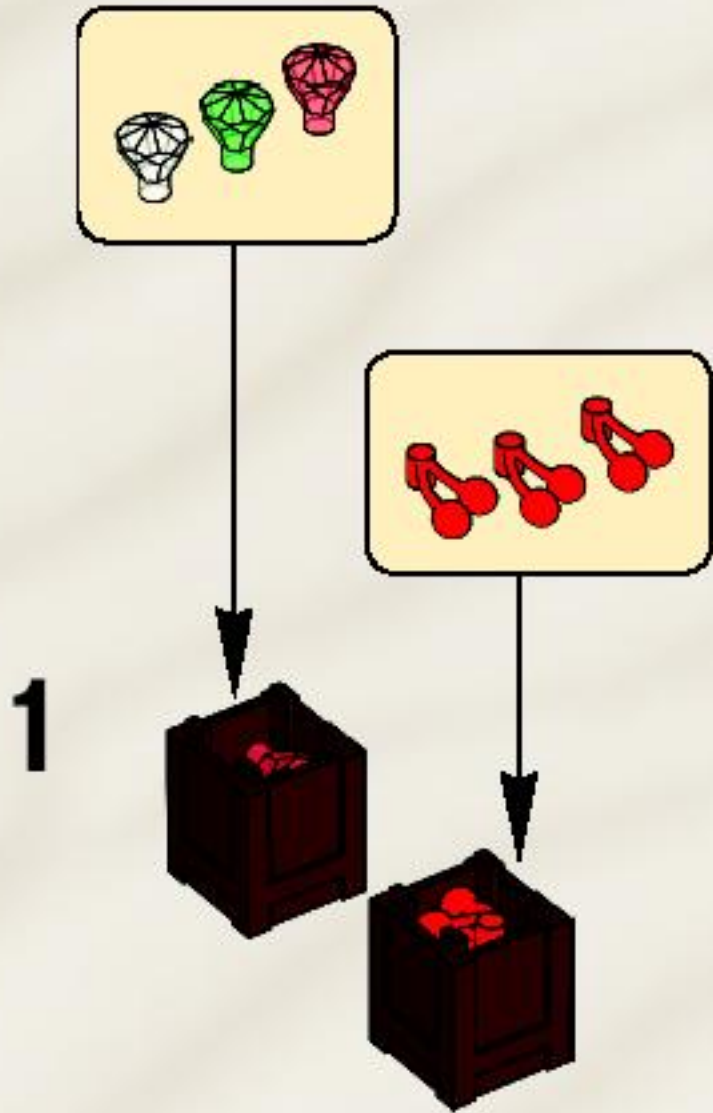

2

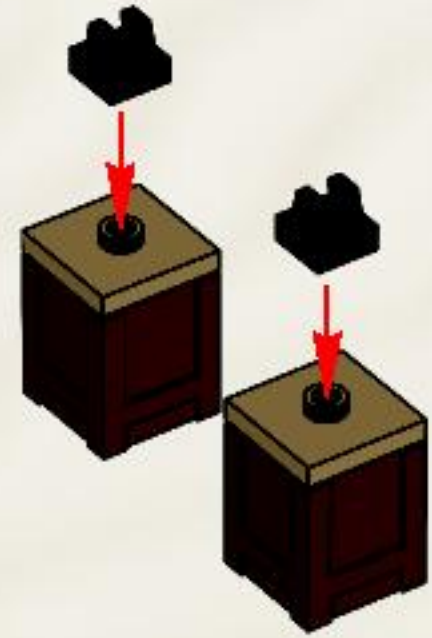

3

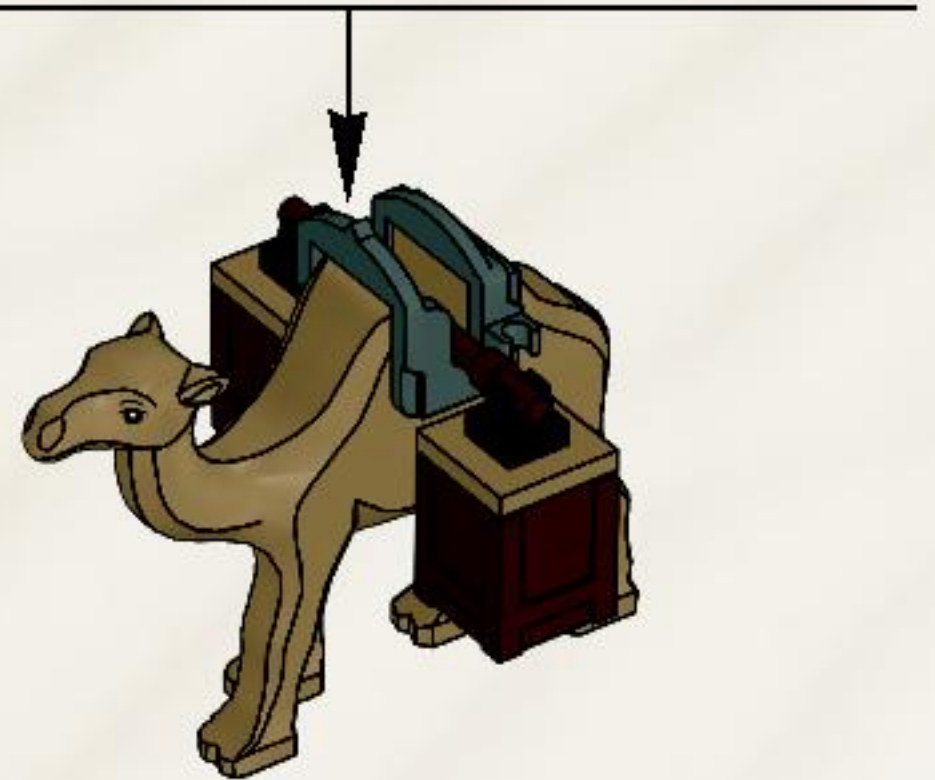
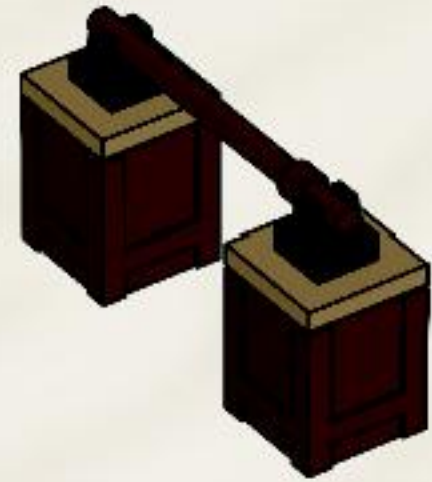

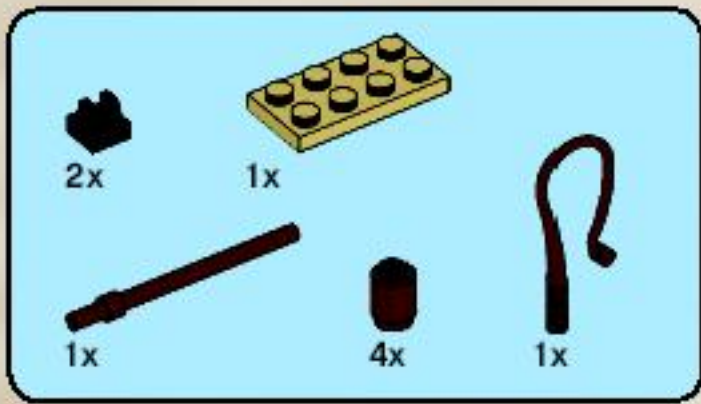

3

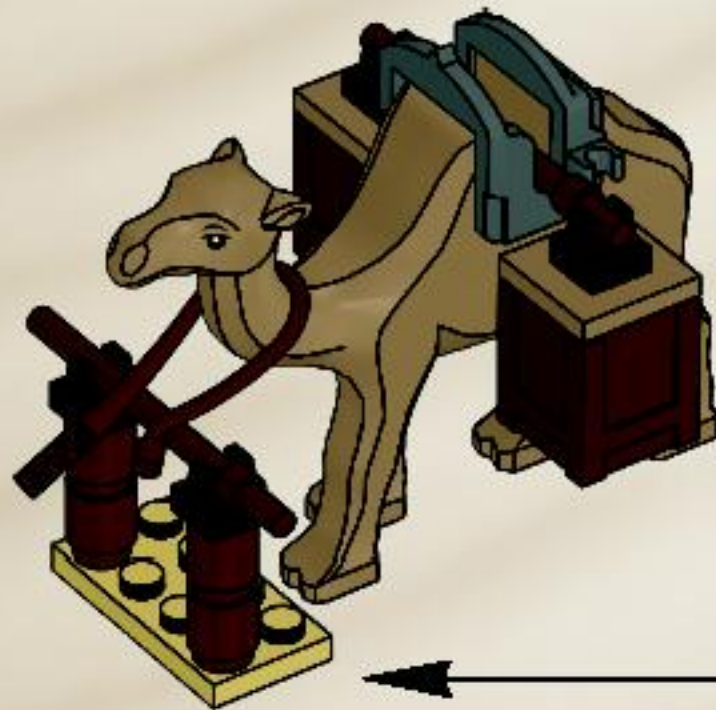
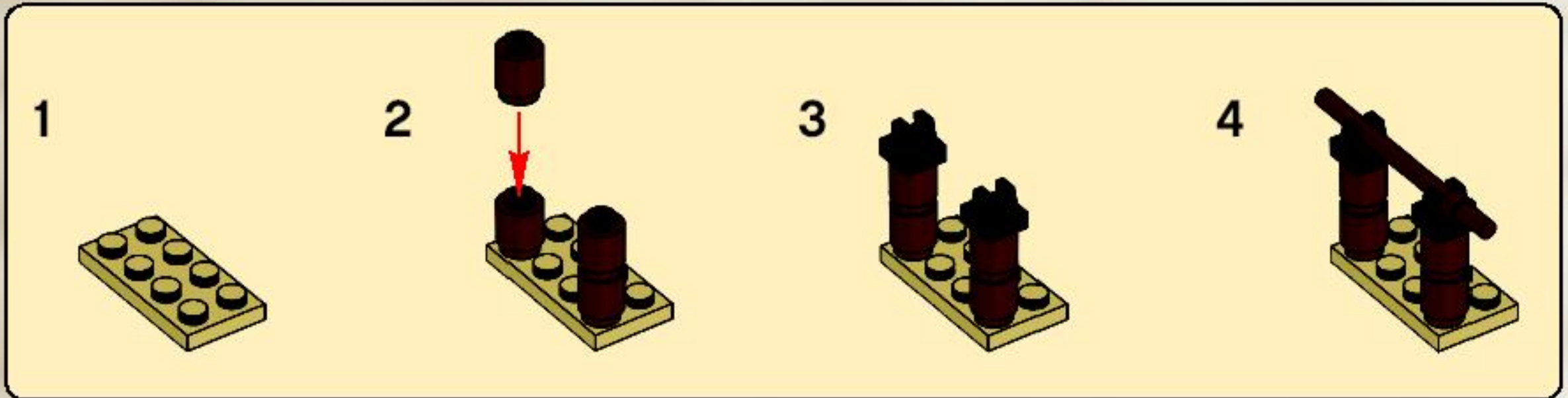

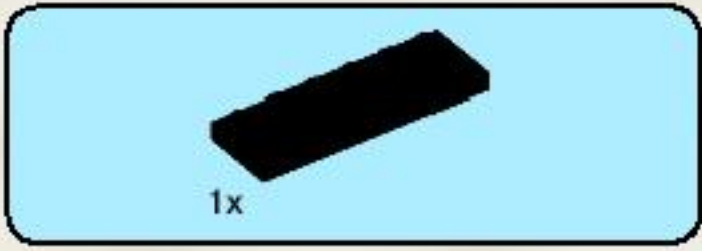

1

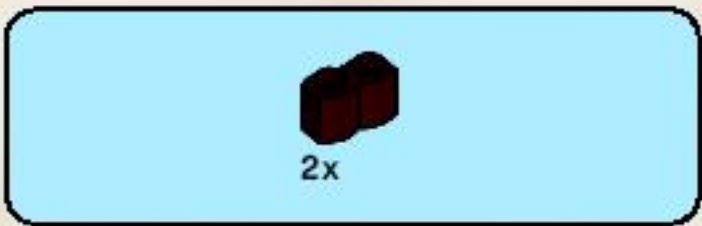

2



3



4

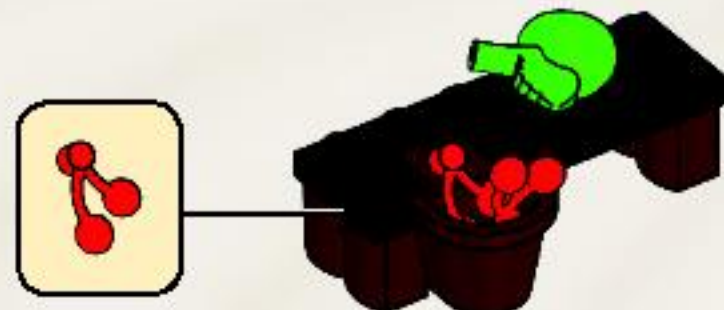



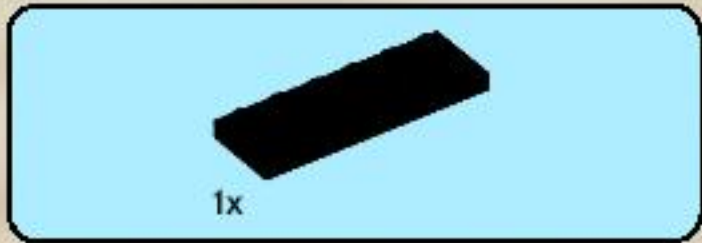

1



2

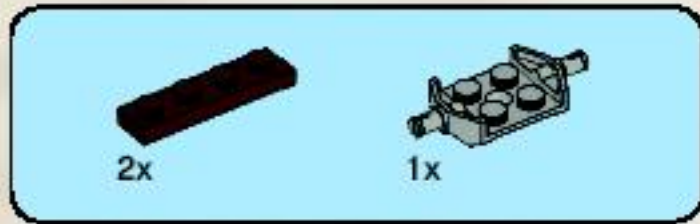

3

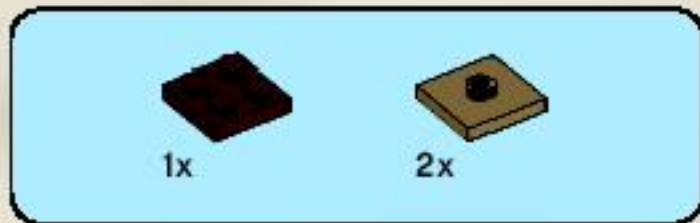

4







5

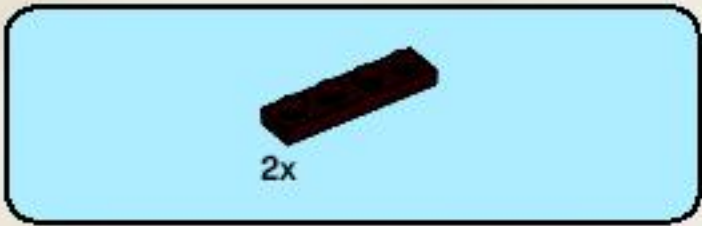
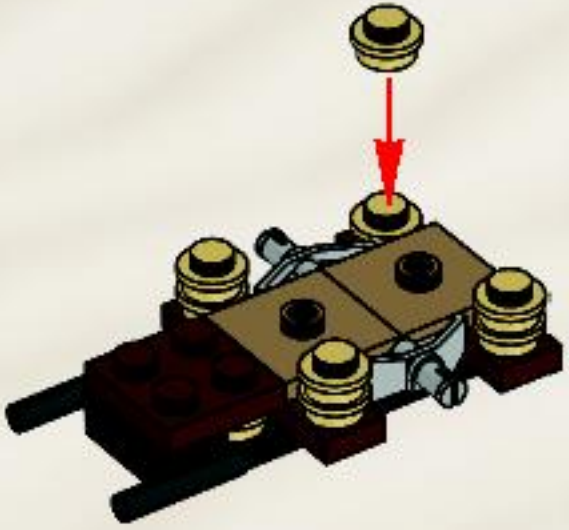

6

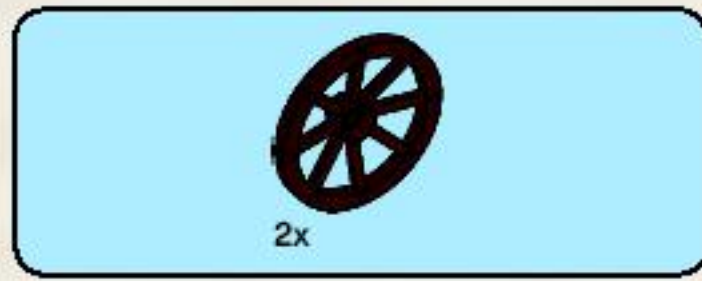
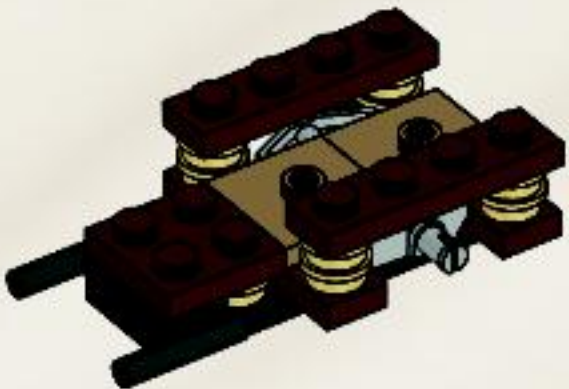

7



8



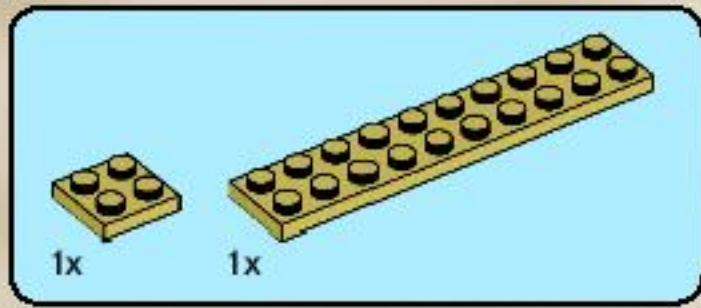
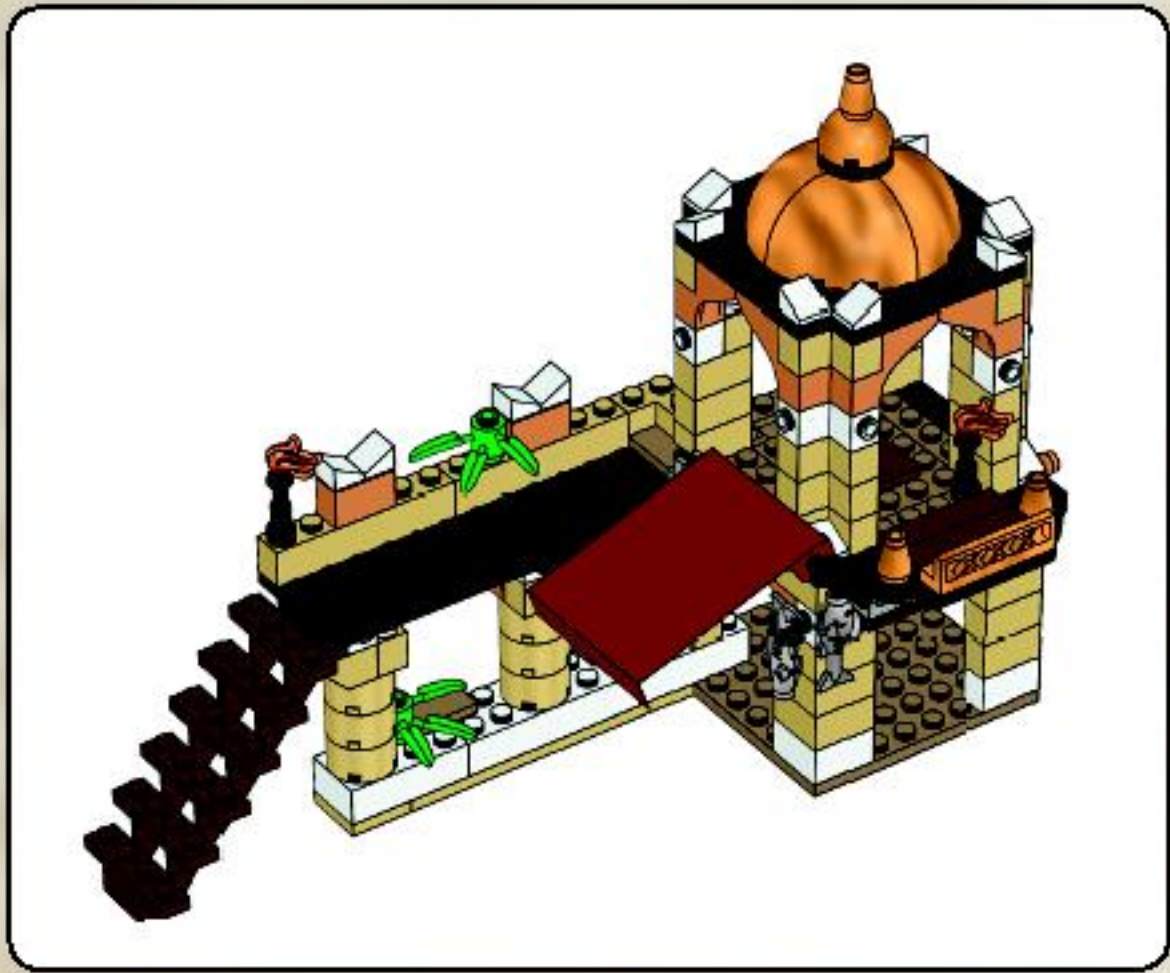

1

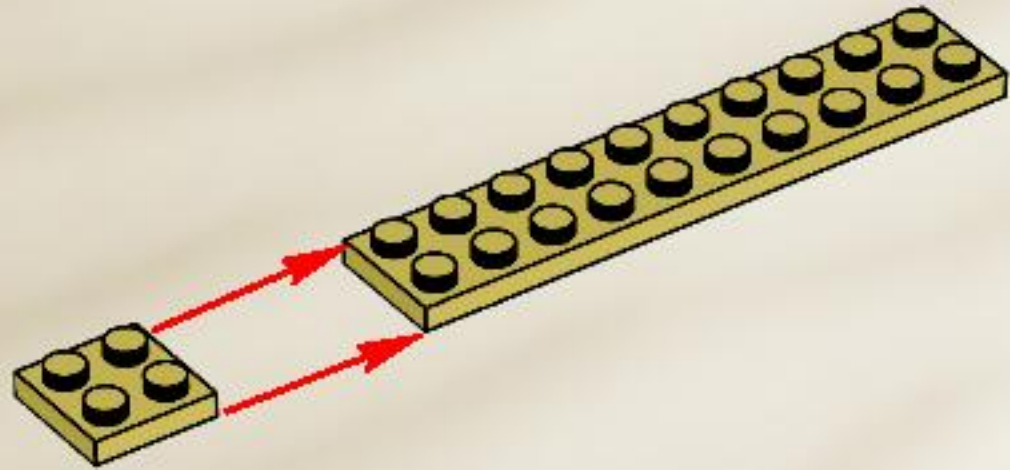



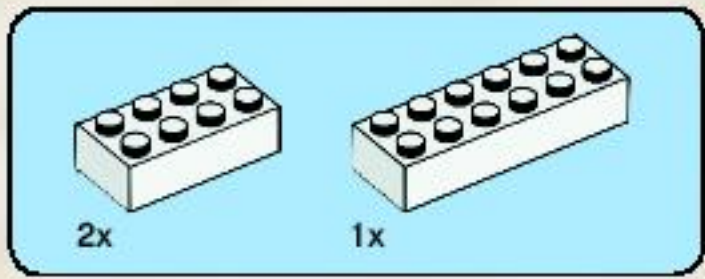

2

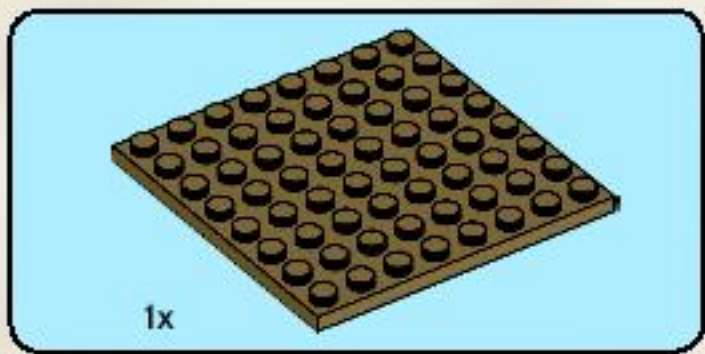
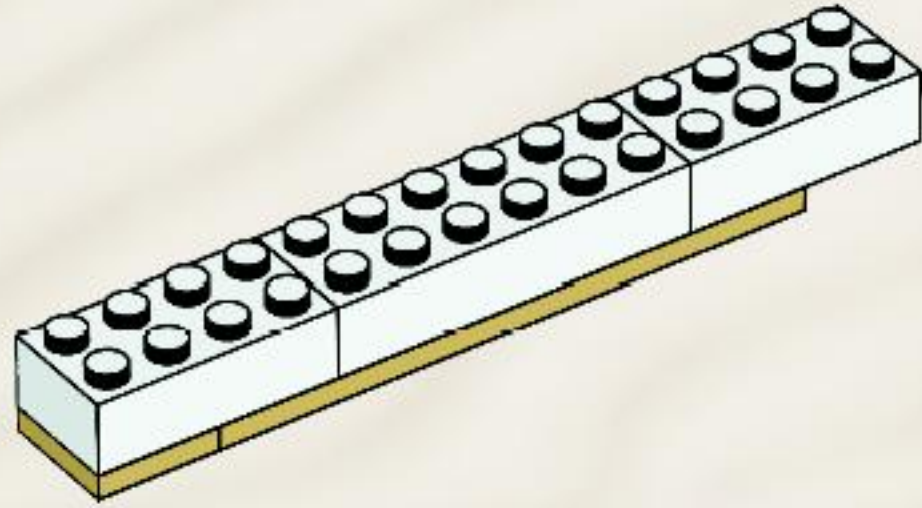

3

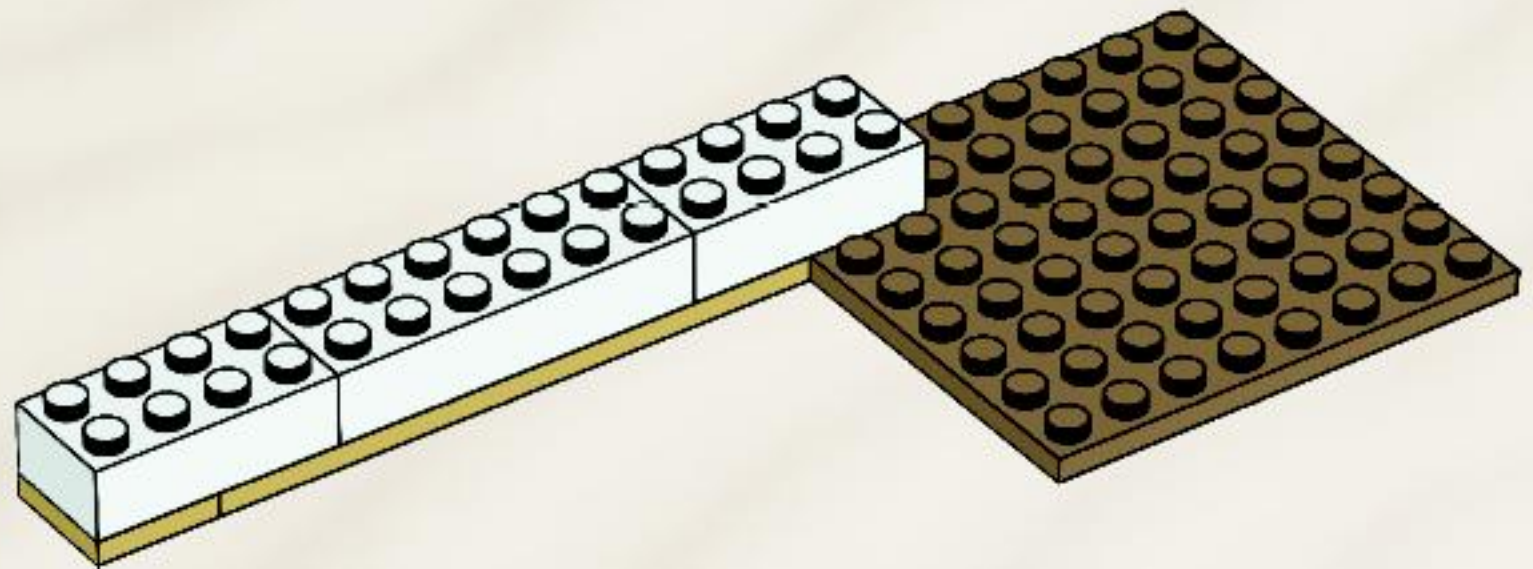

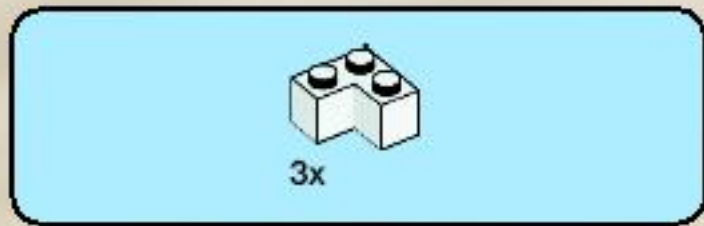

4

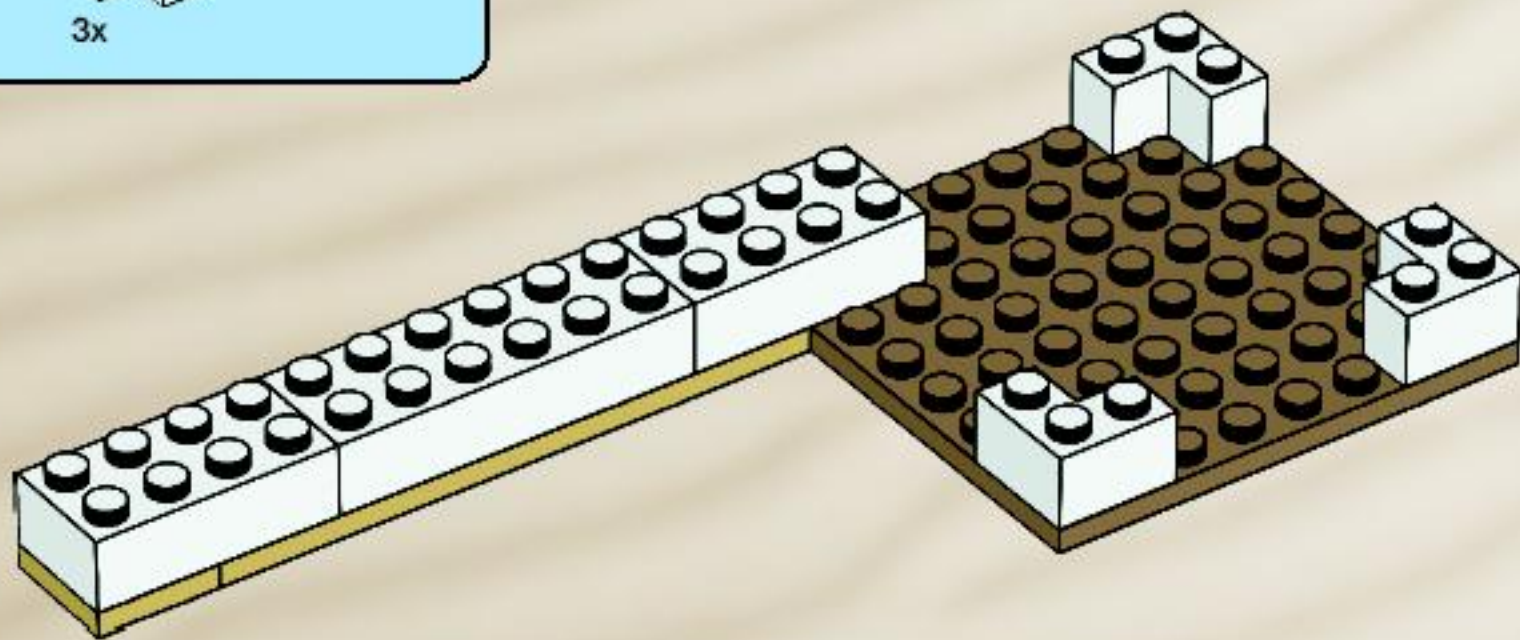

5

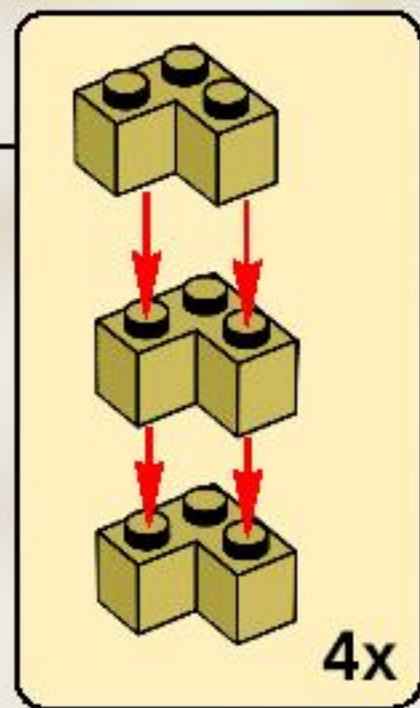
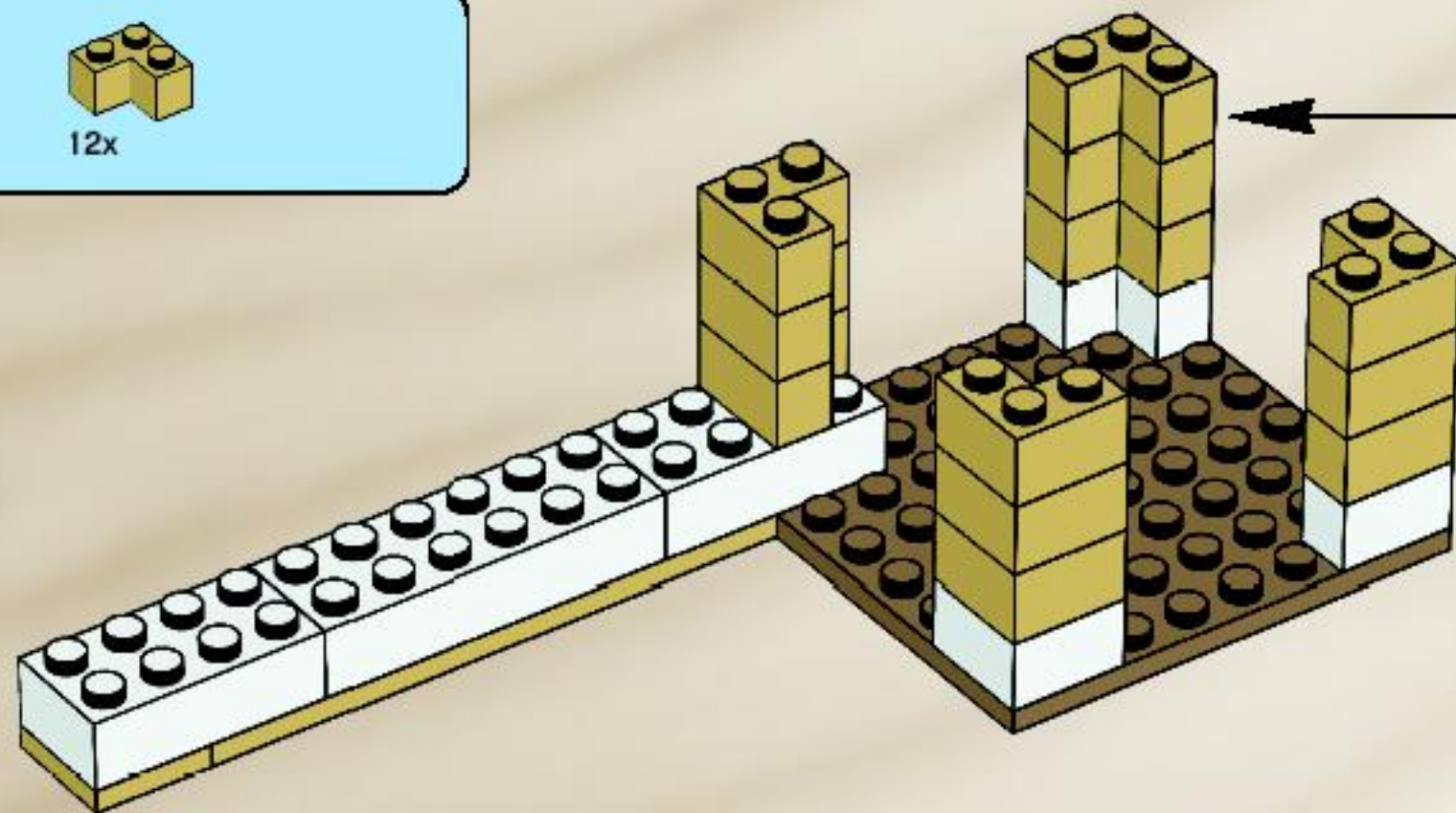



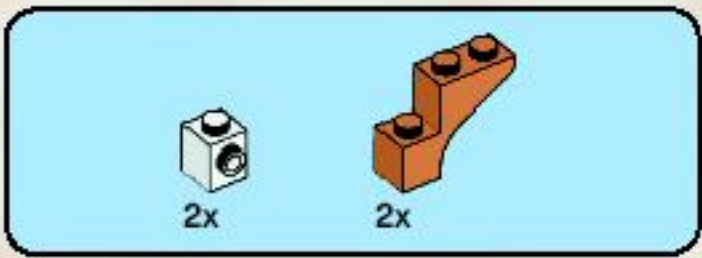

6

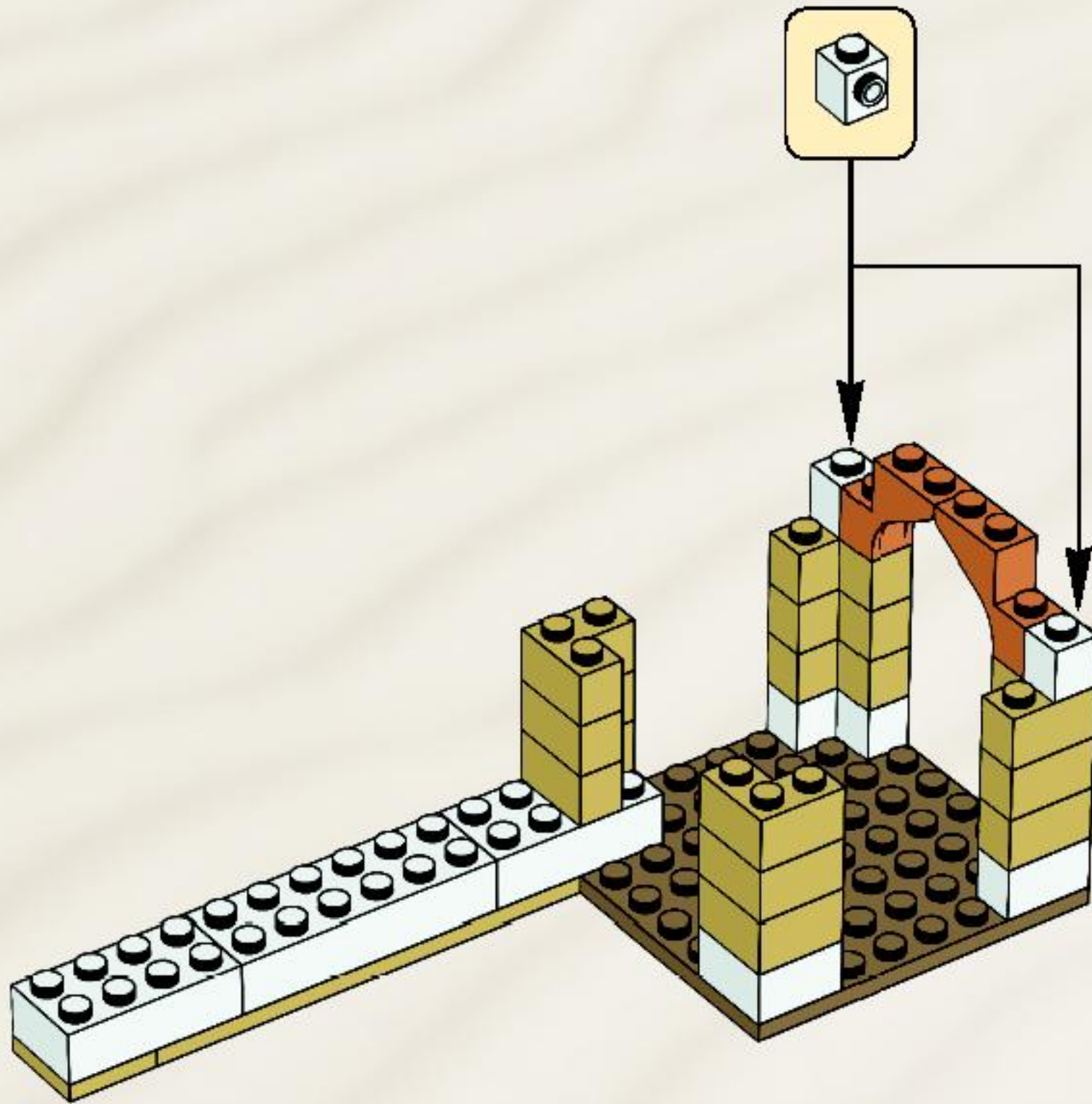

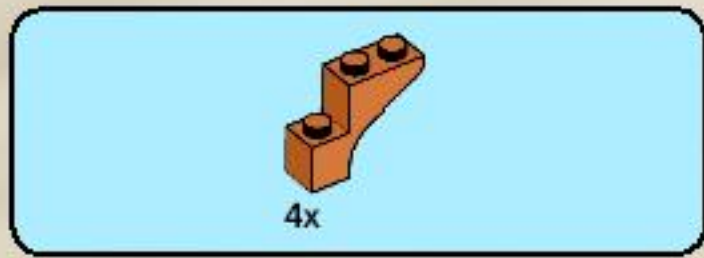

7

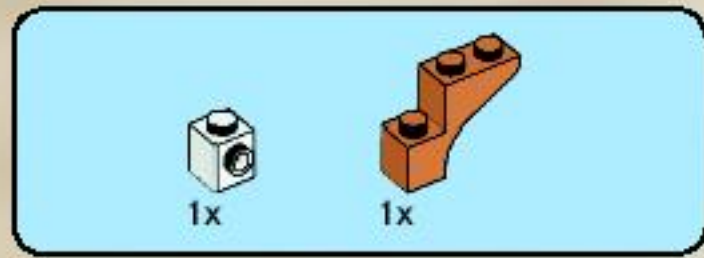
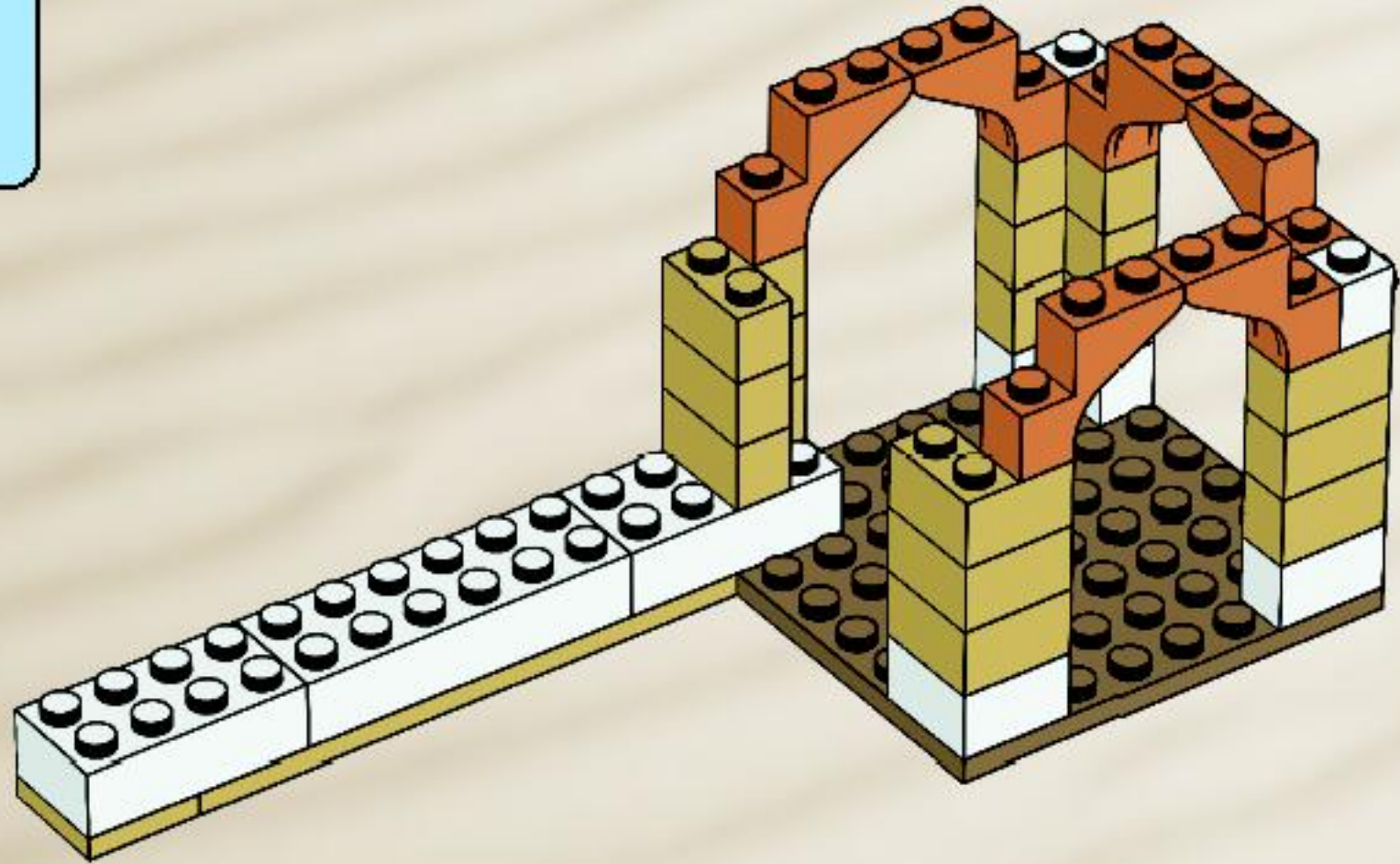

8

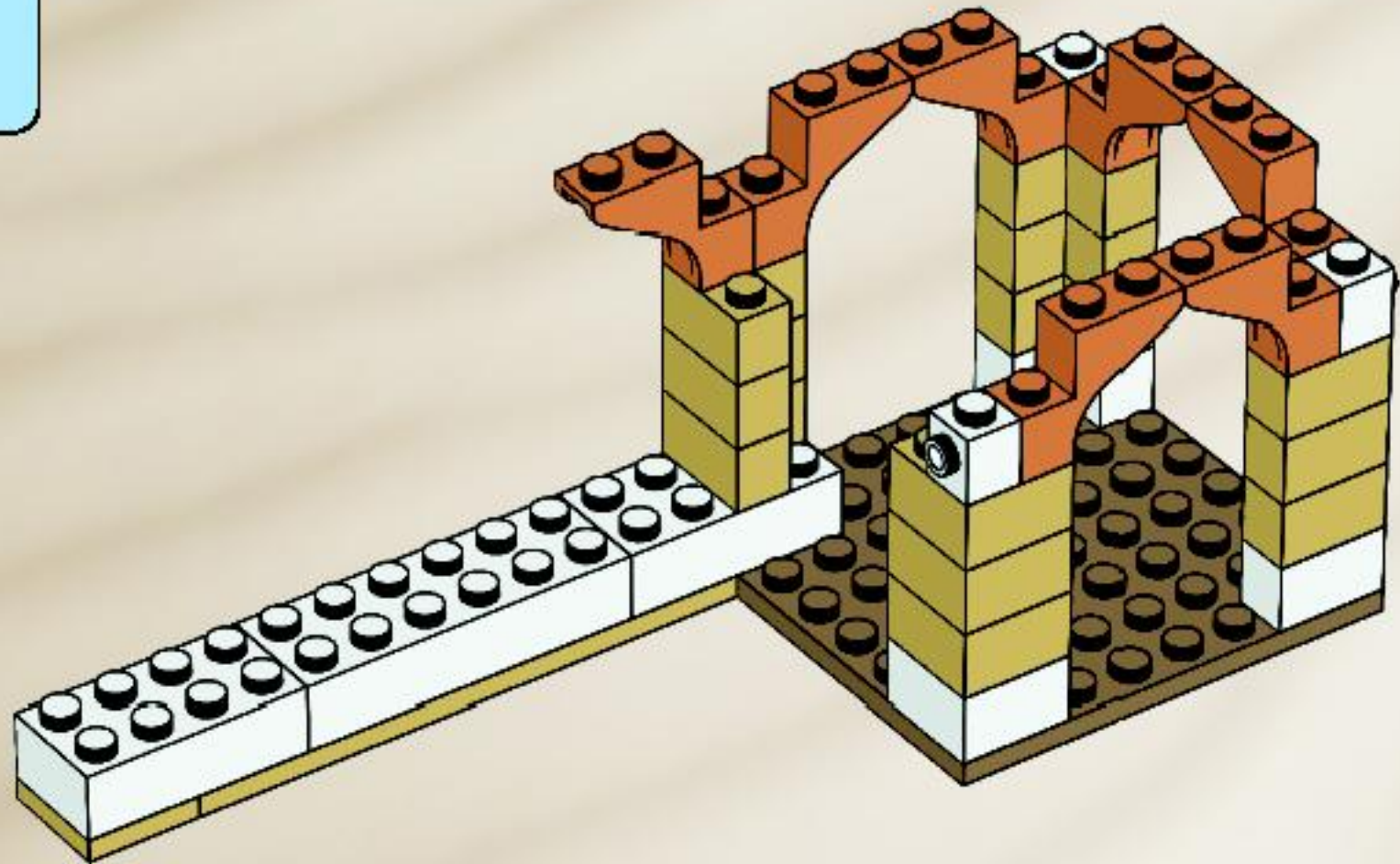



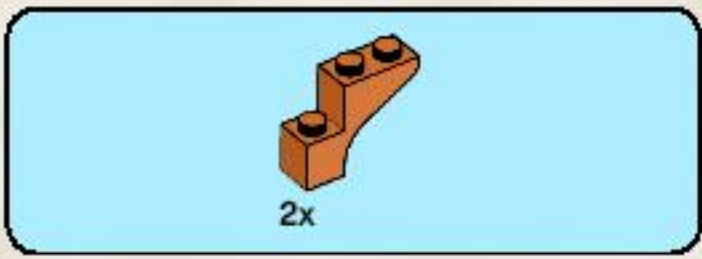

9

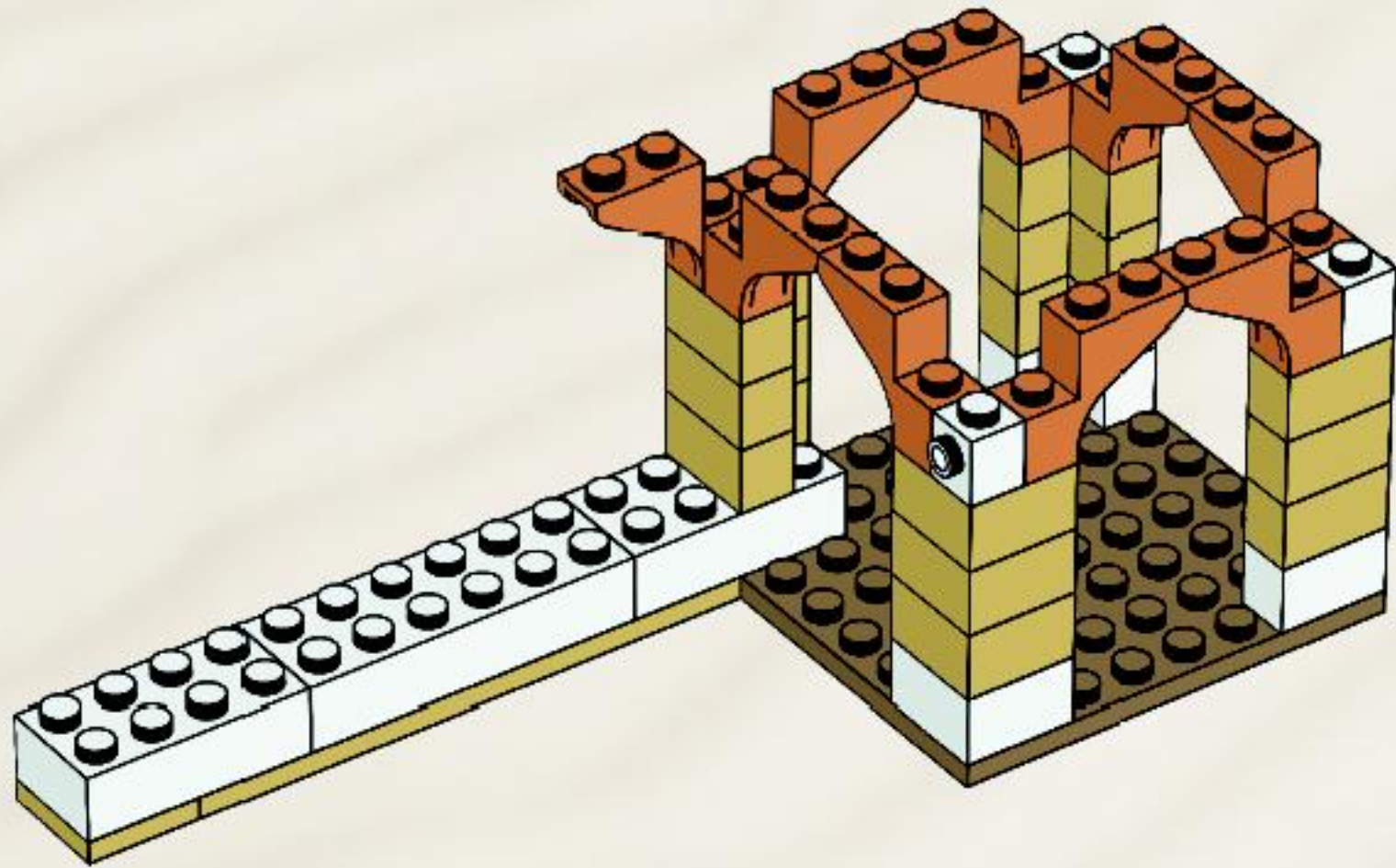



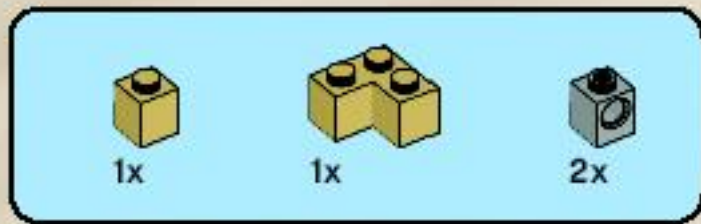

10

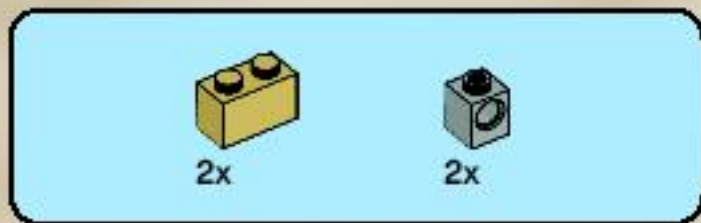
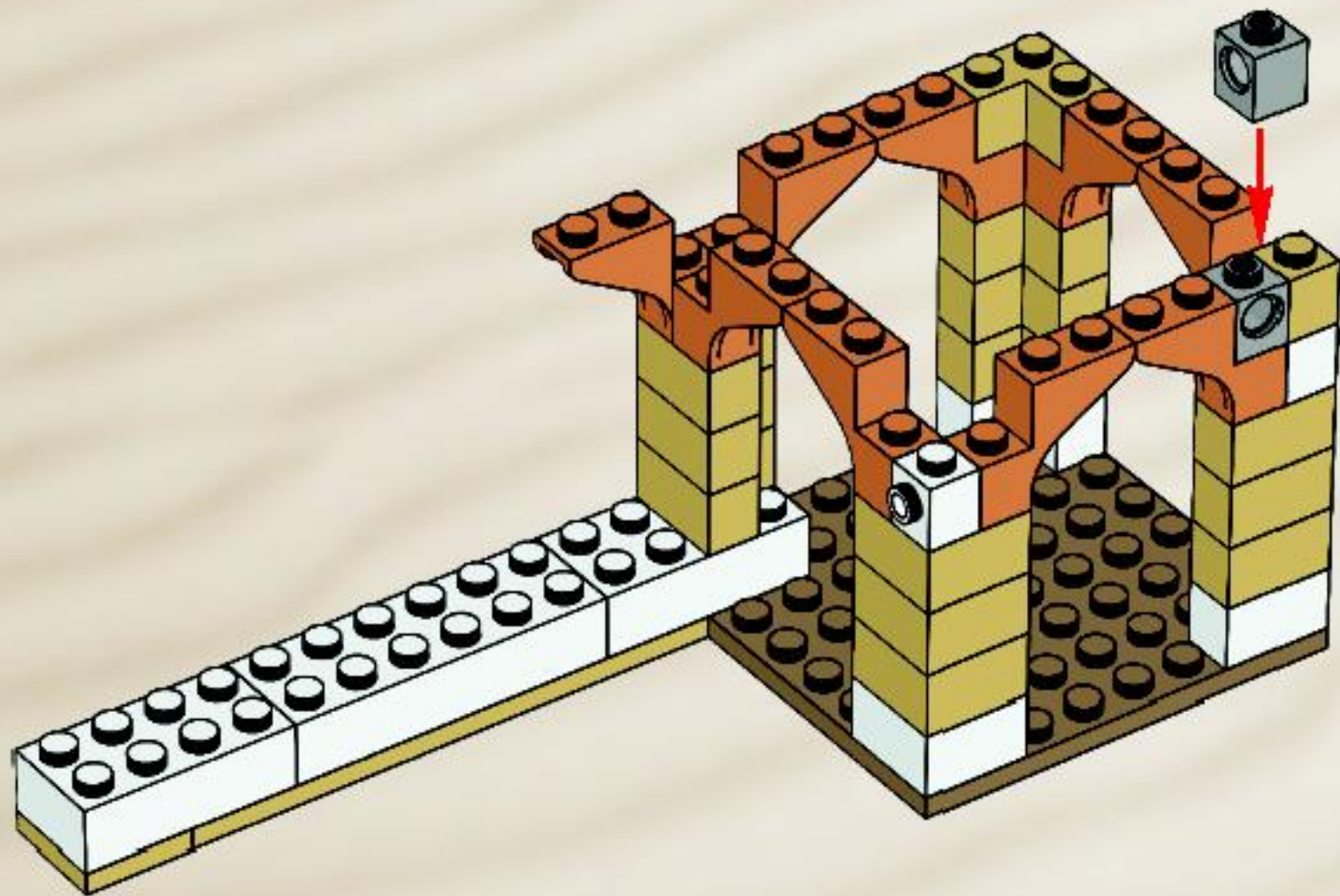

11

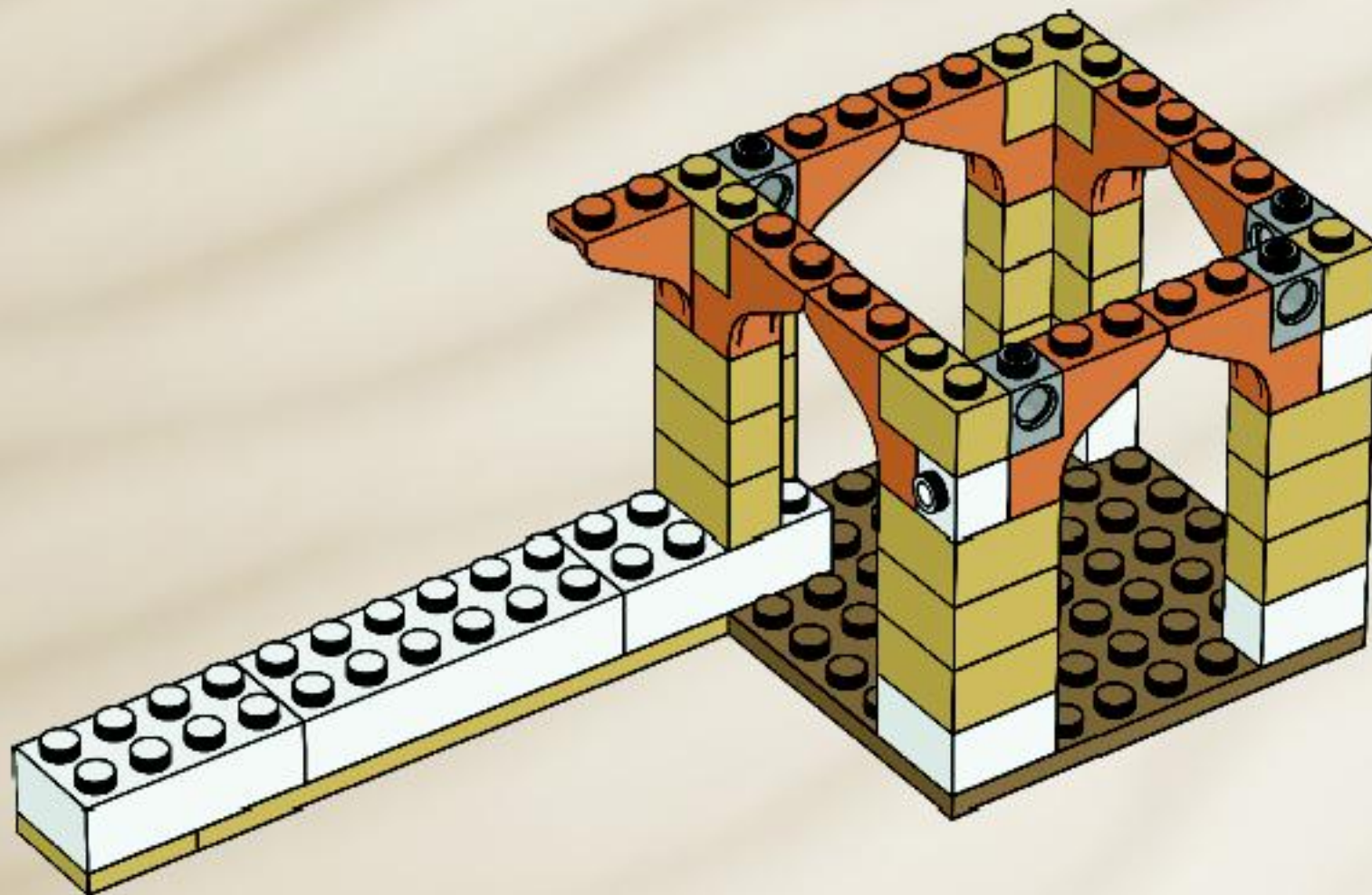



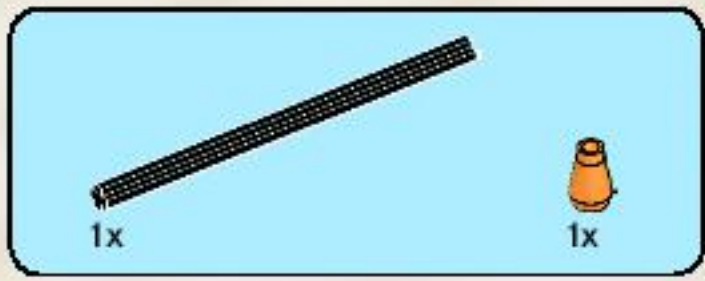

12

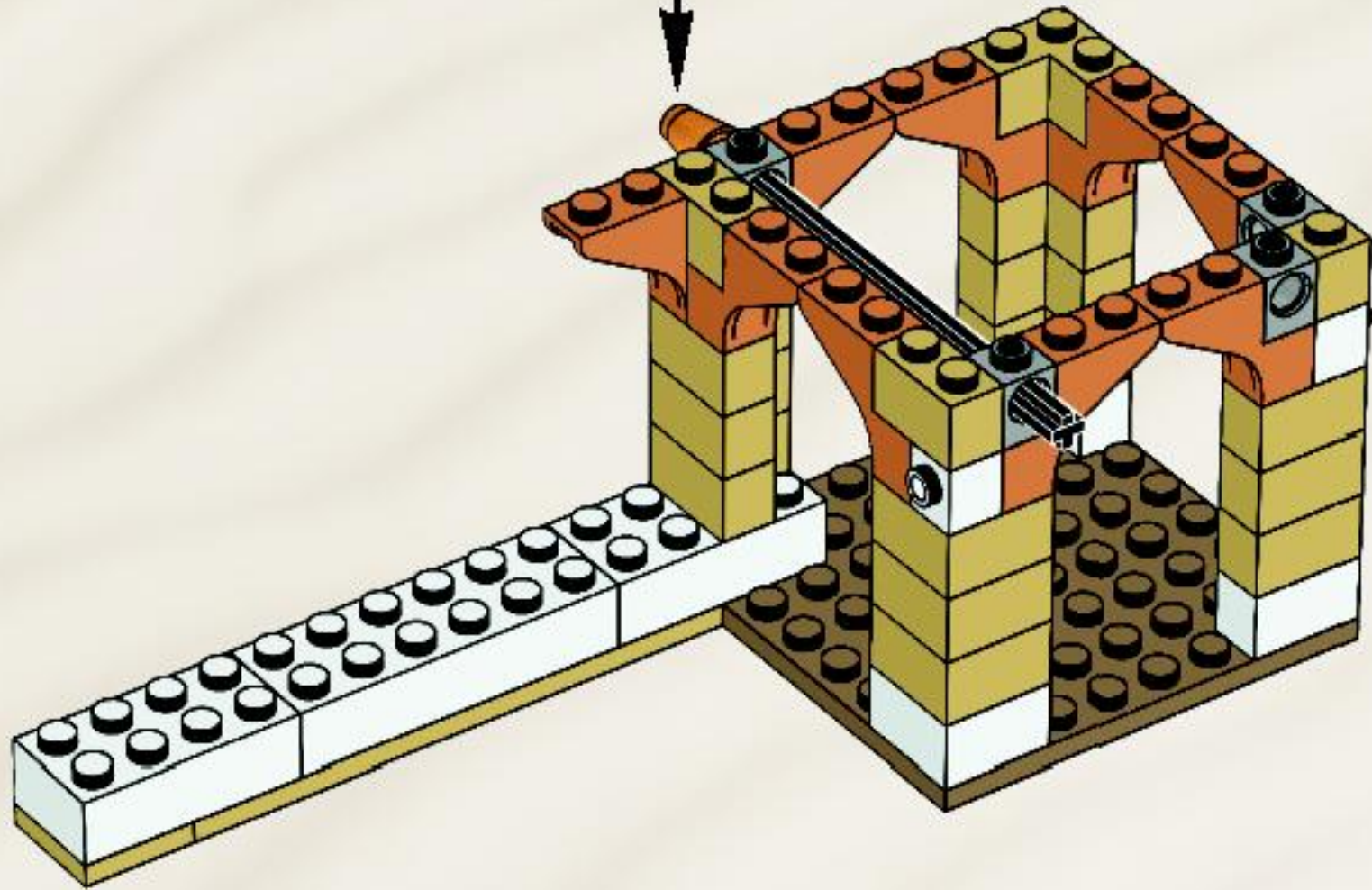
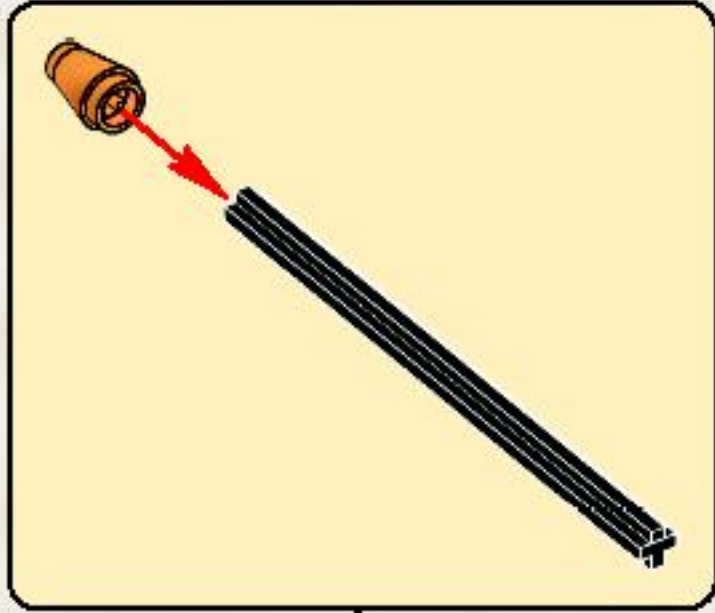

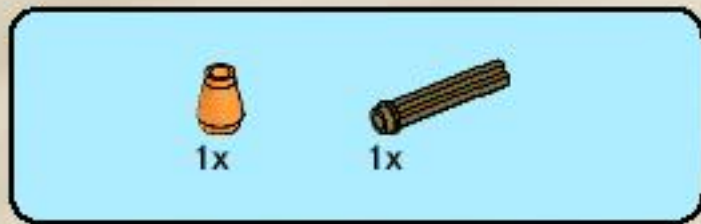

13

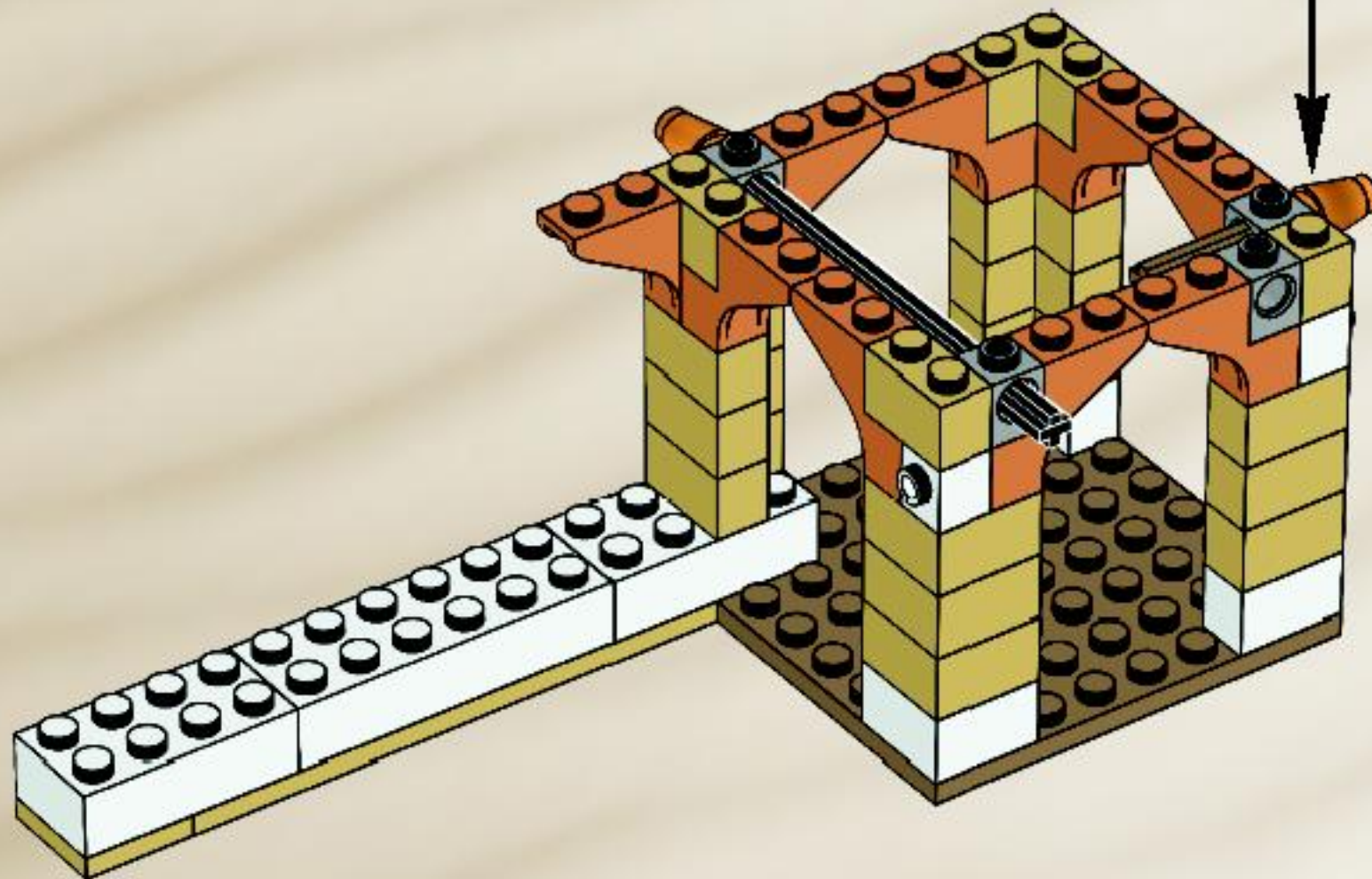
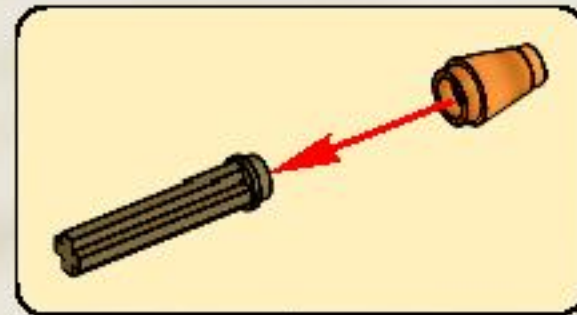



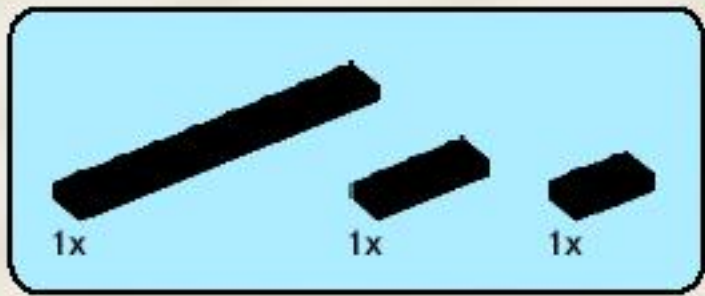

14

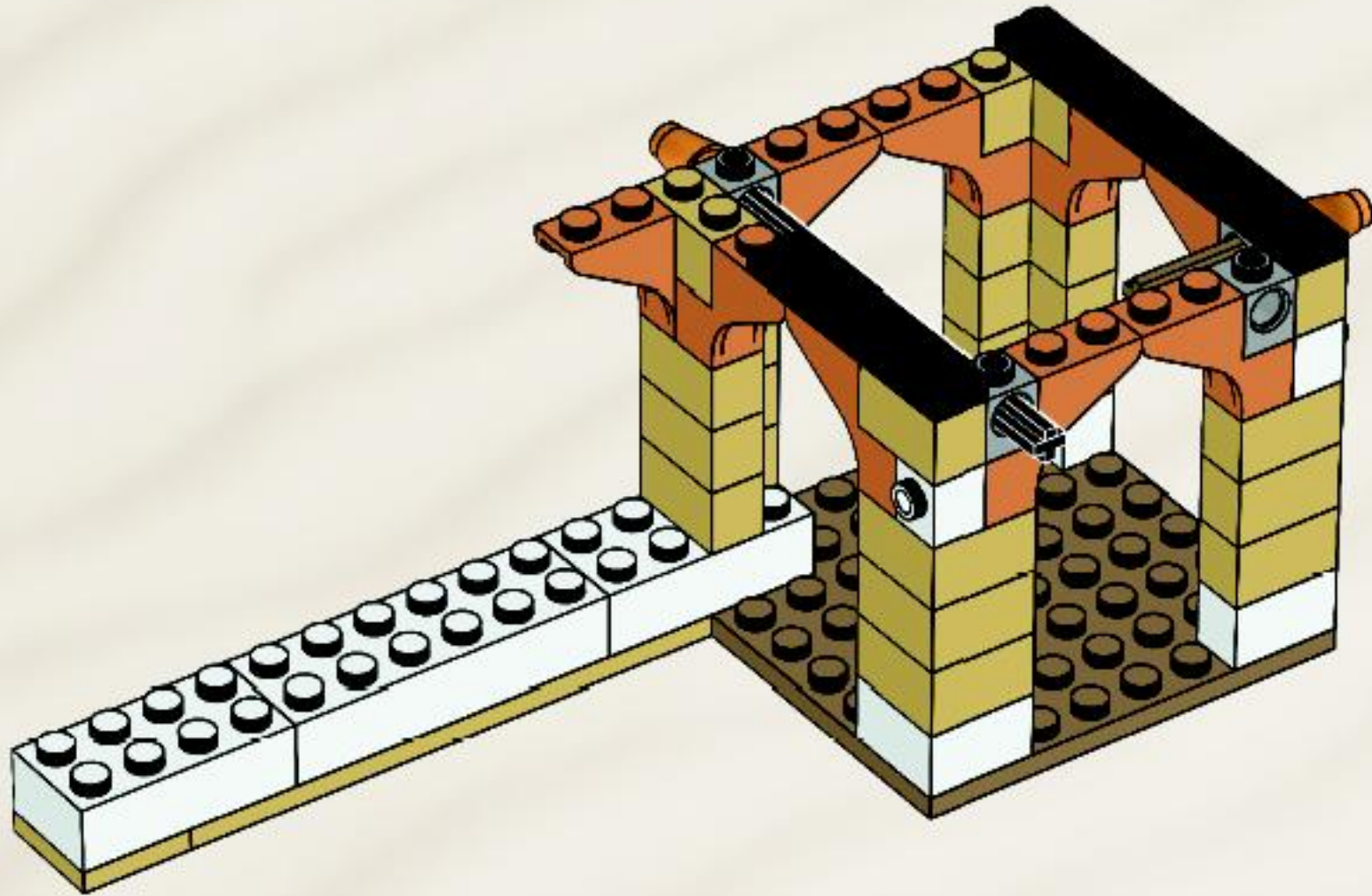









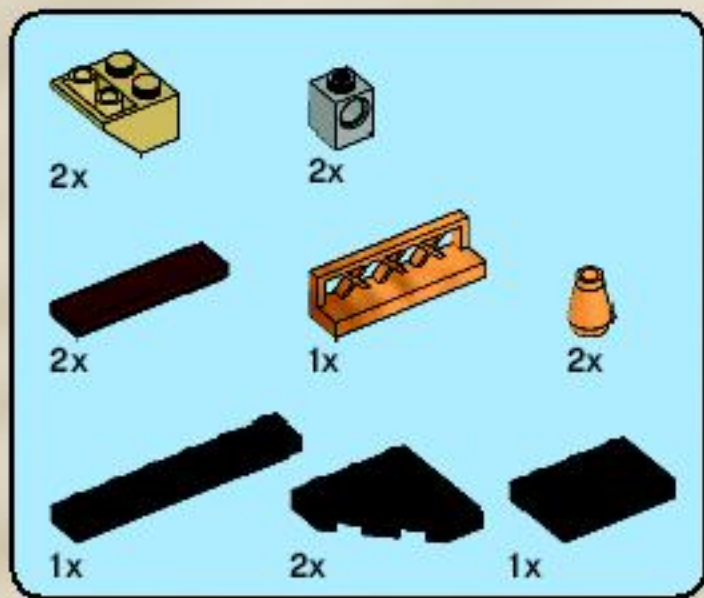

17

1



2

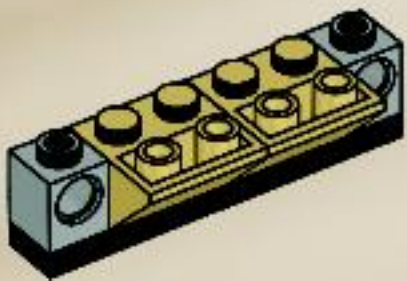

3

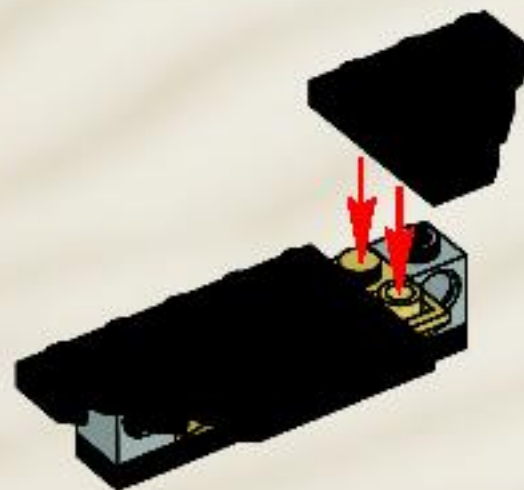

4



5





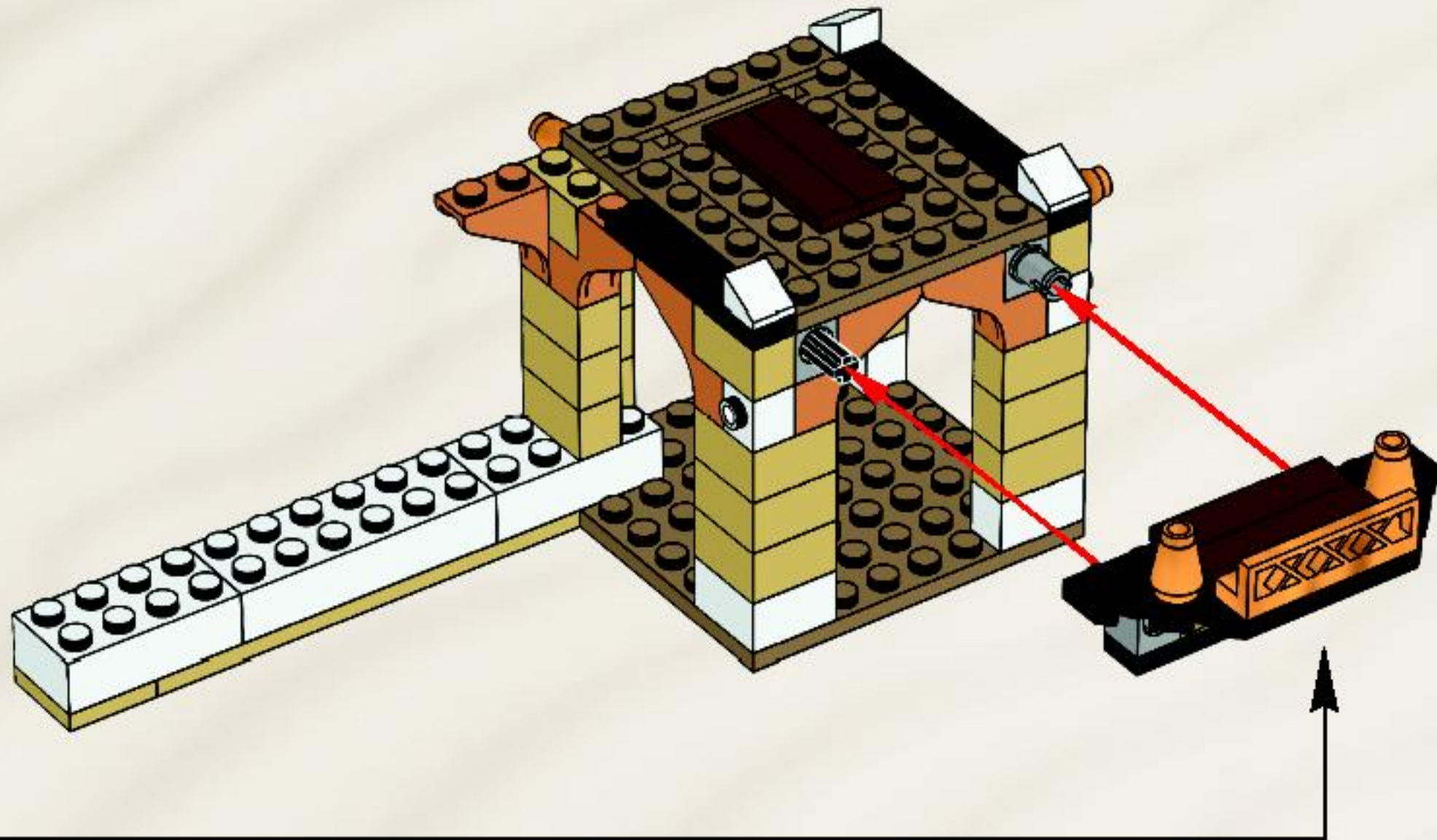
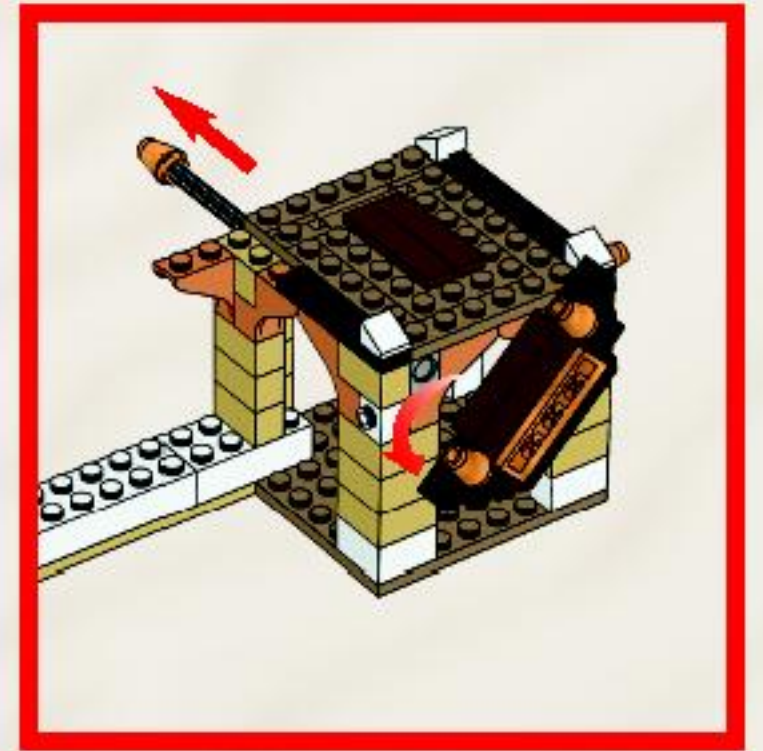



18

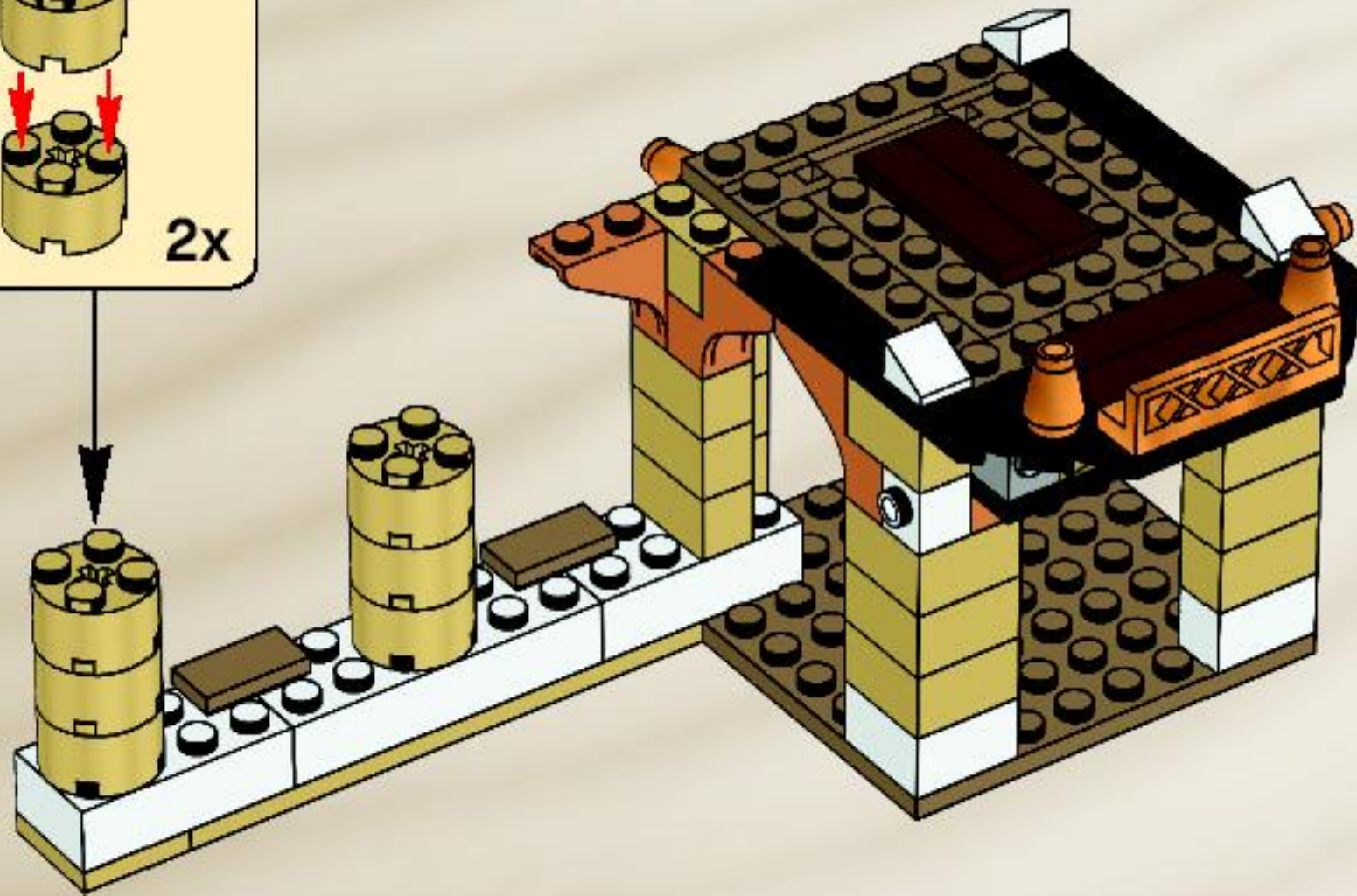
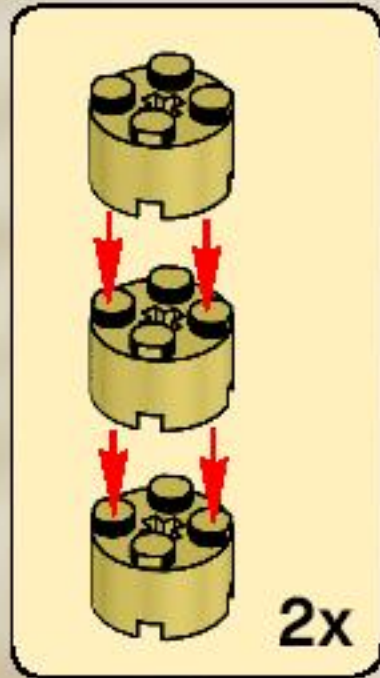



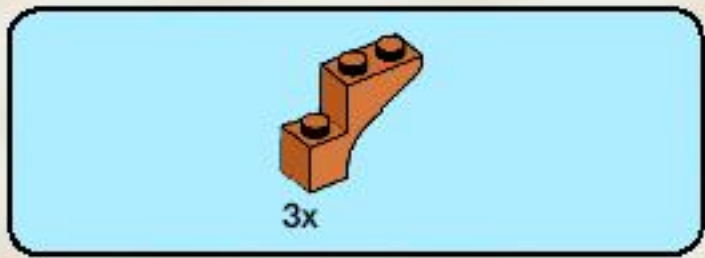

19

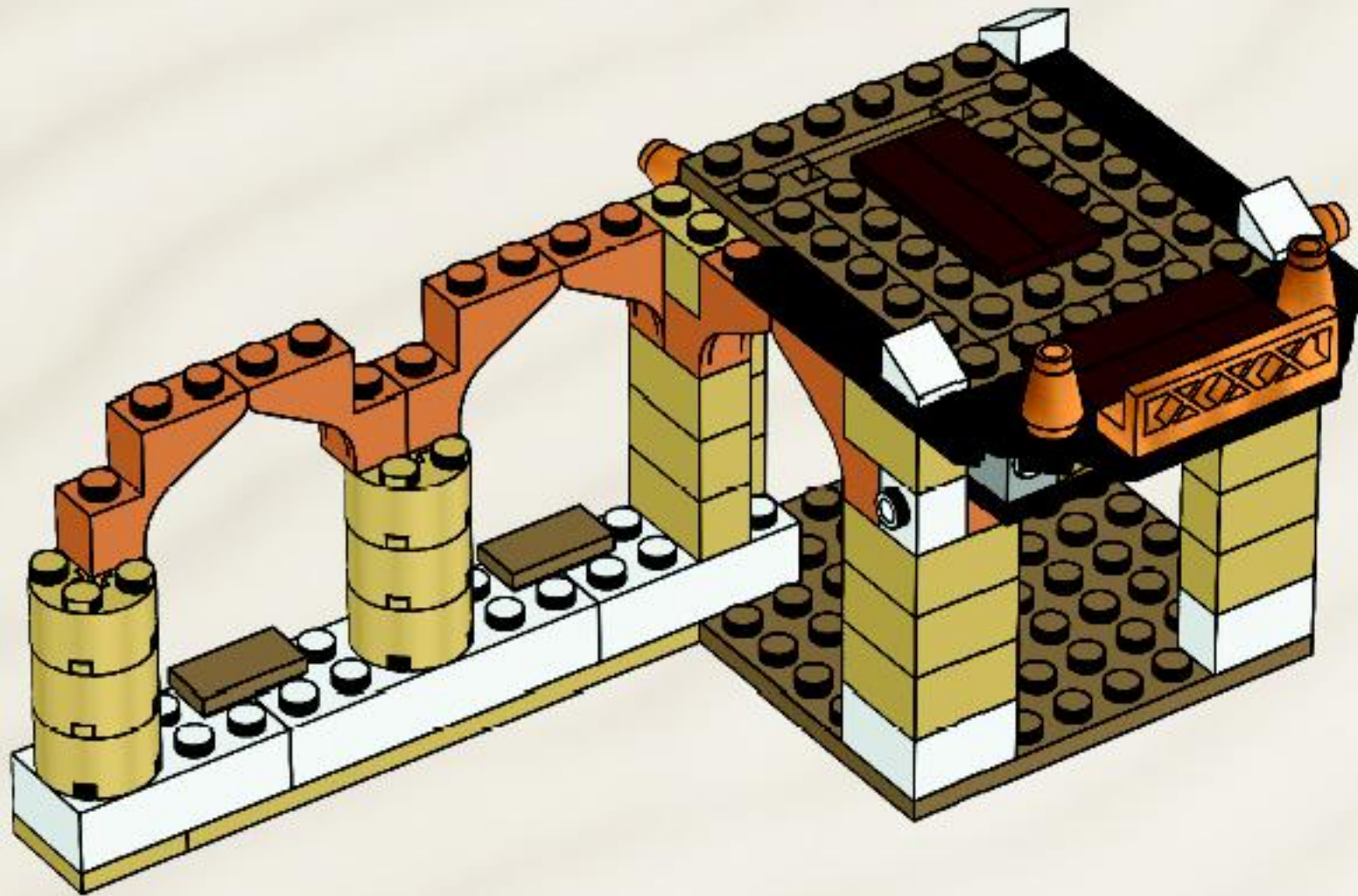

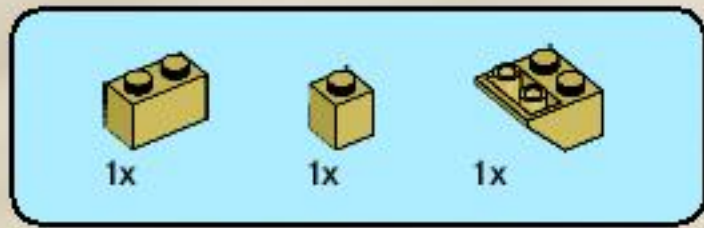

20

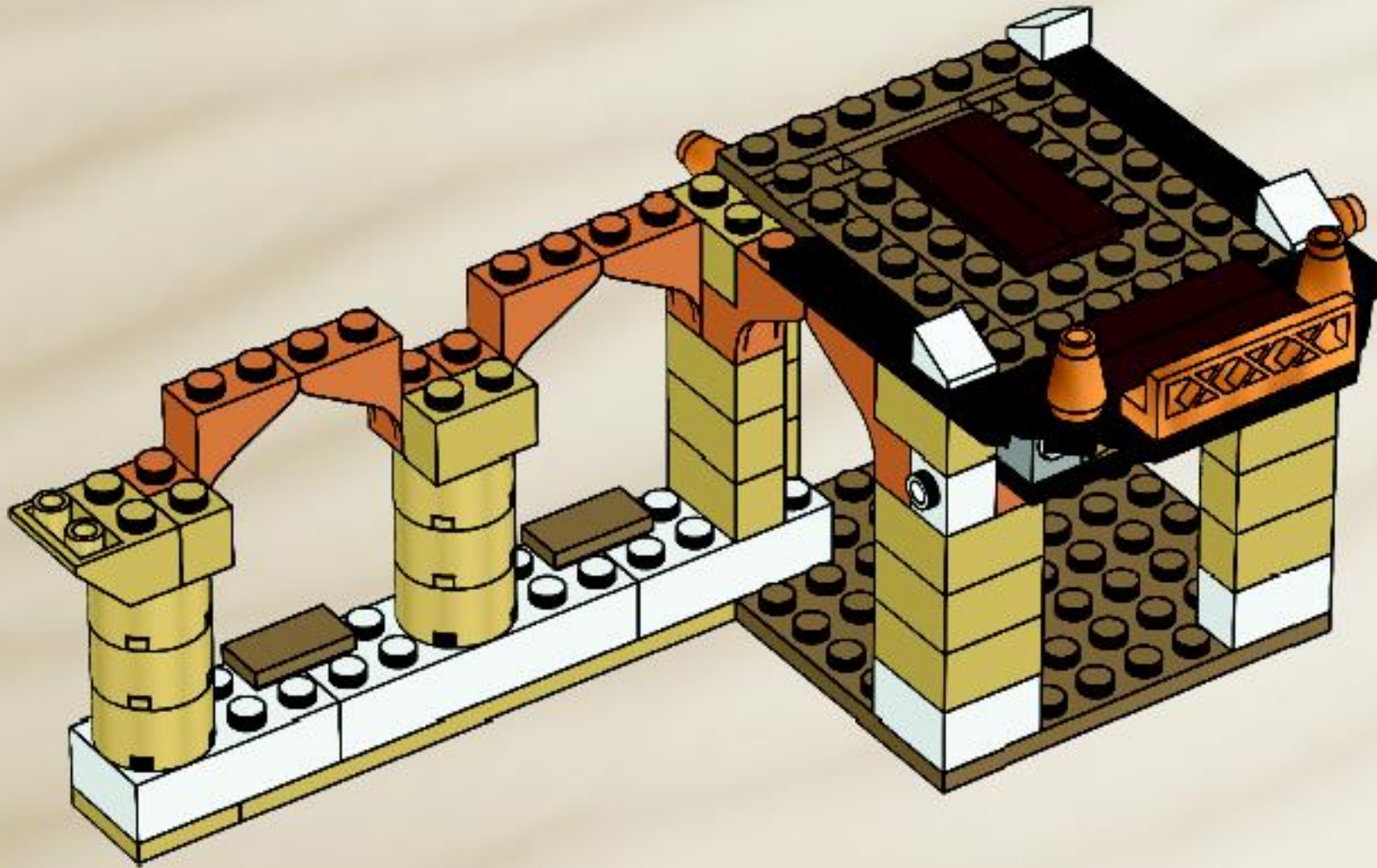



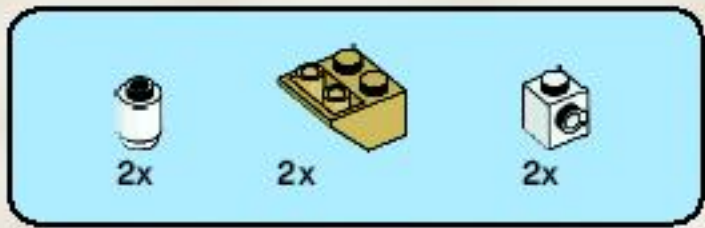

21

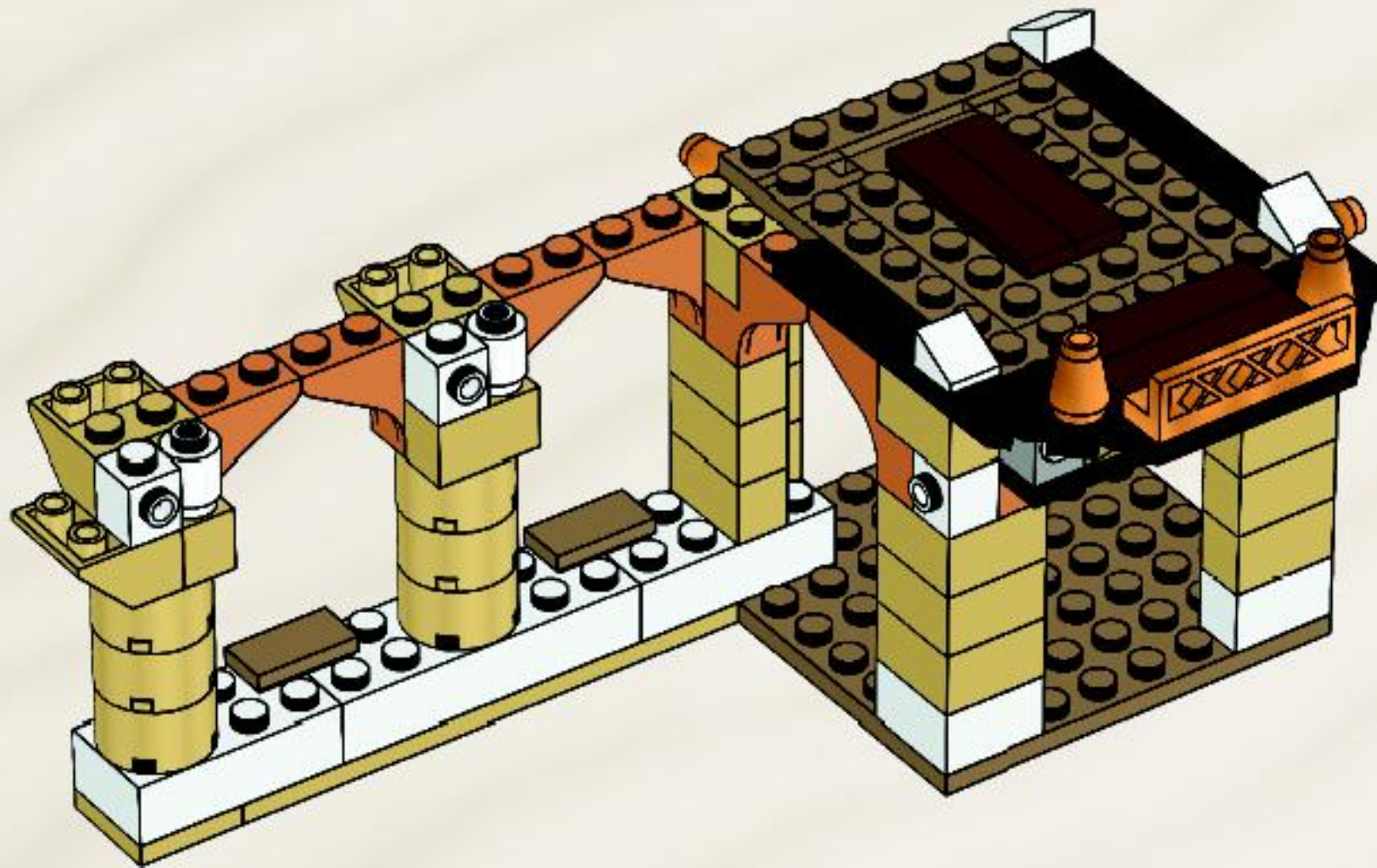



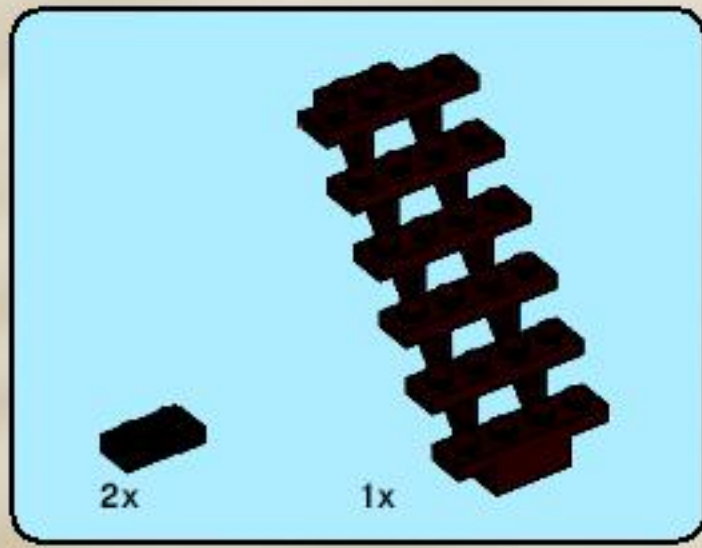

22

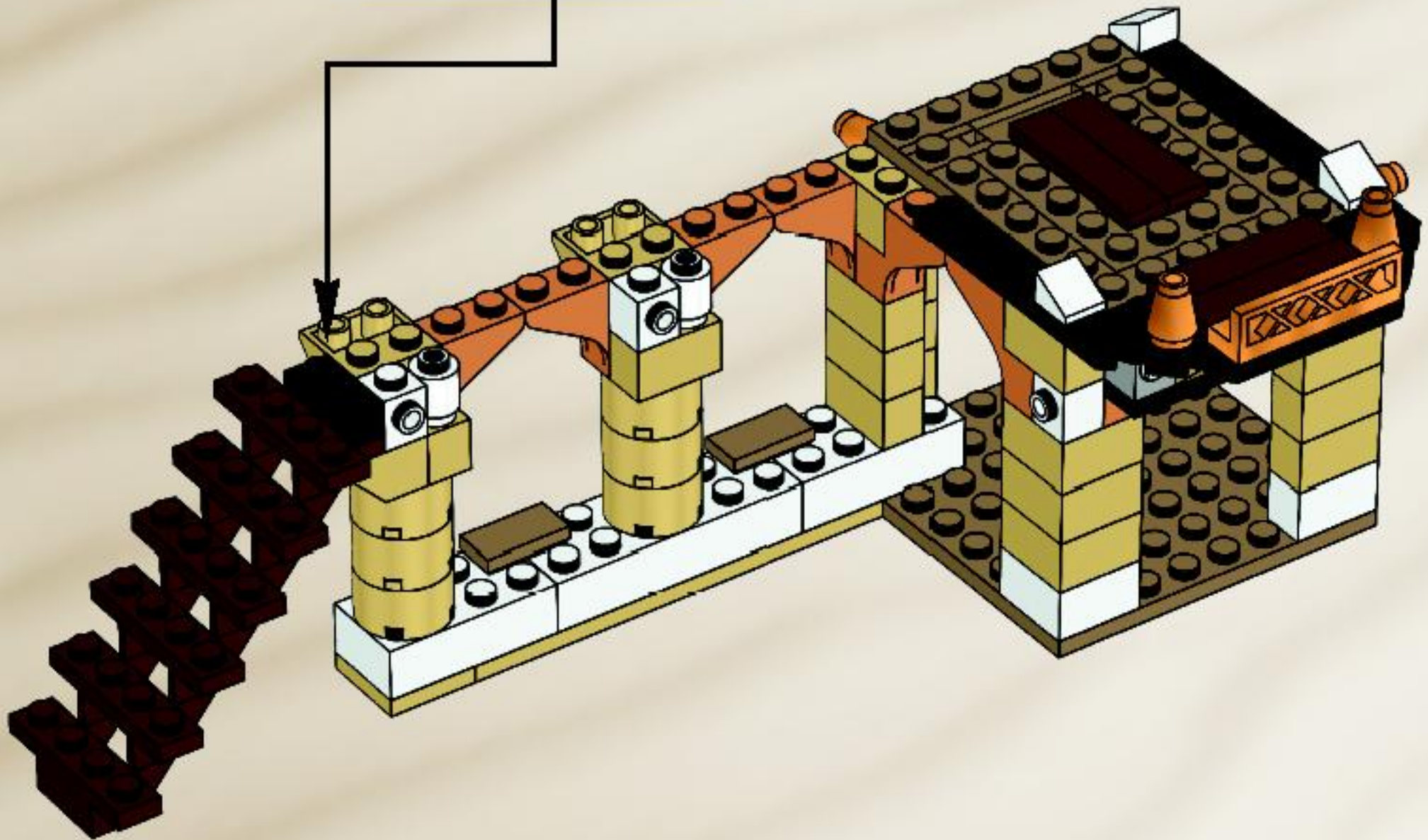
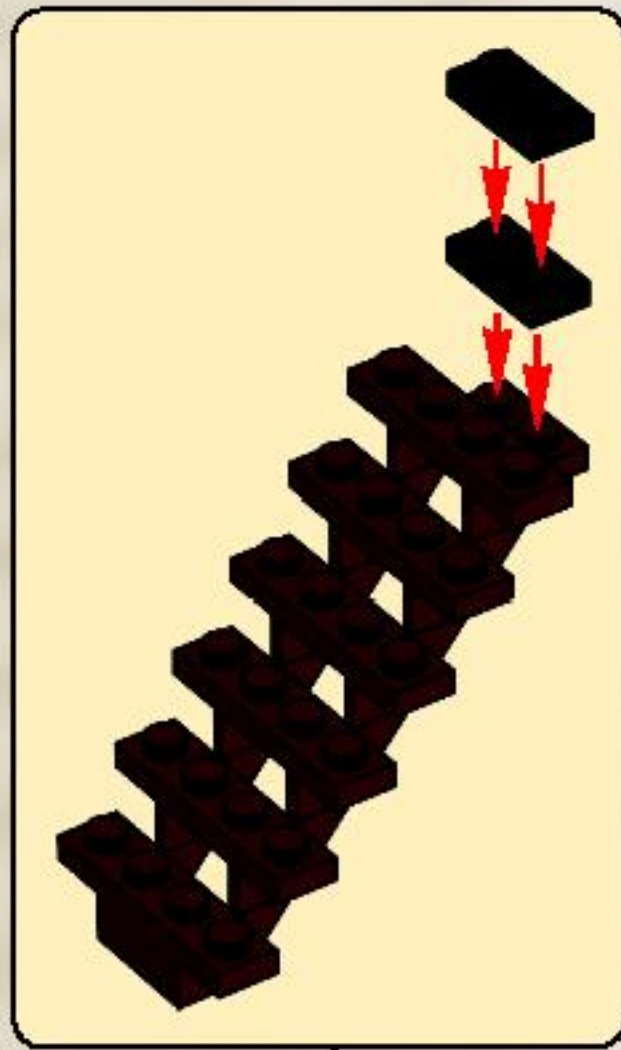



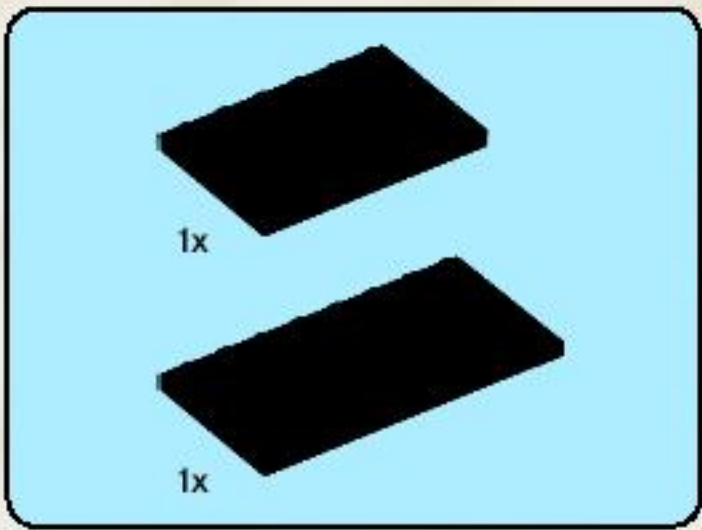

23

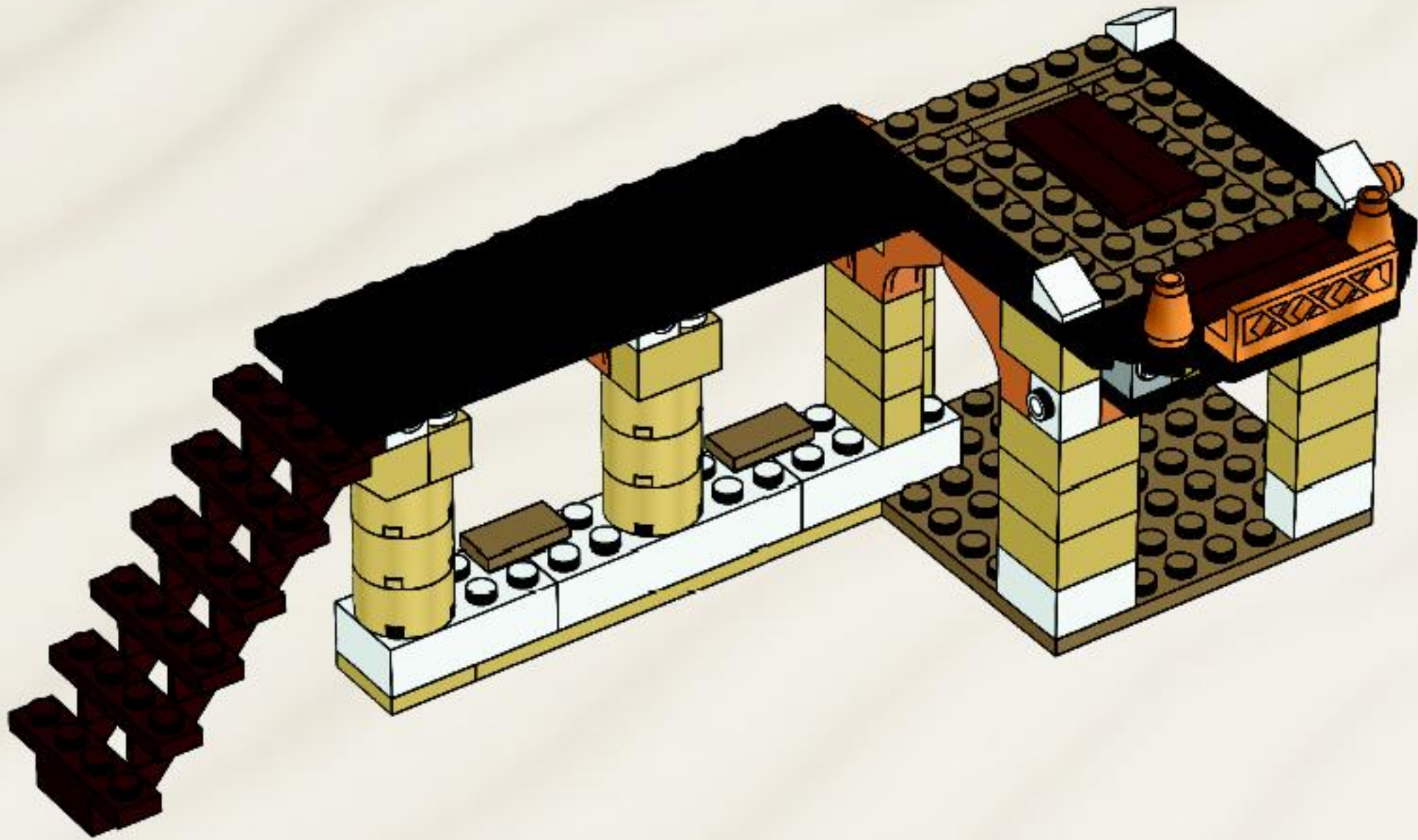





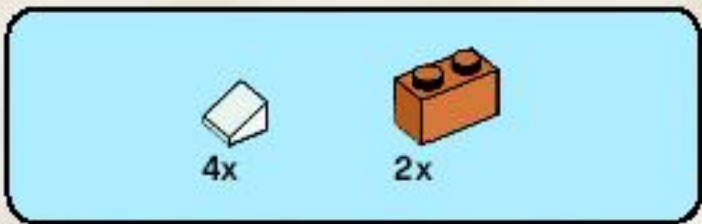

# 25

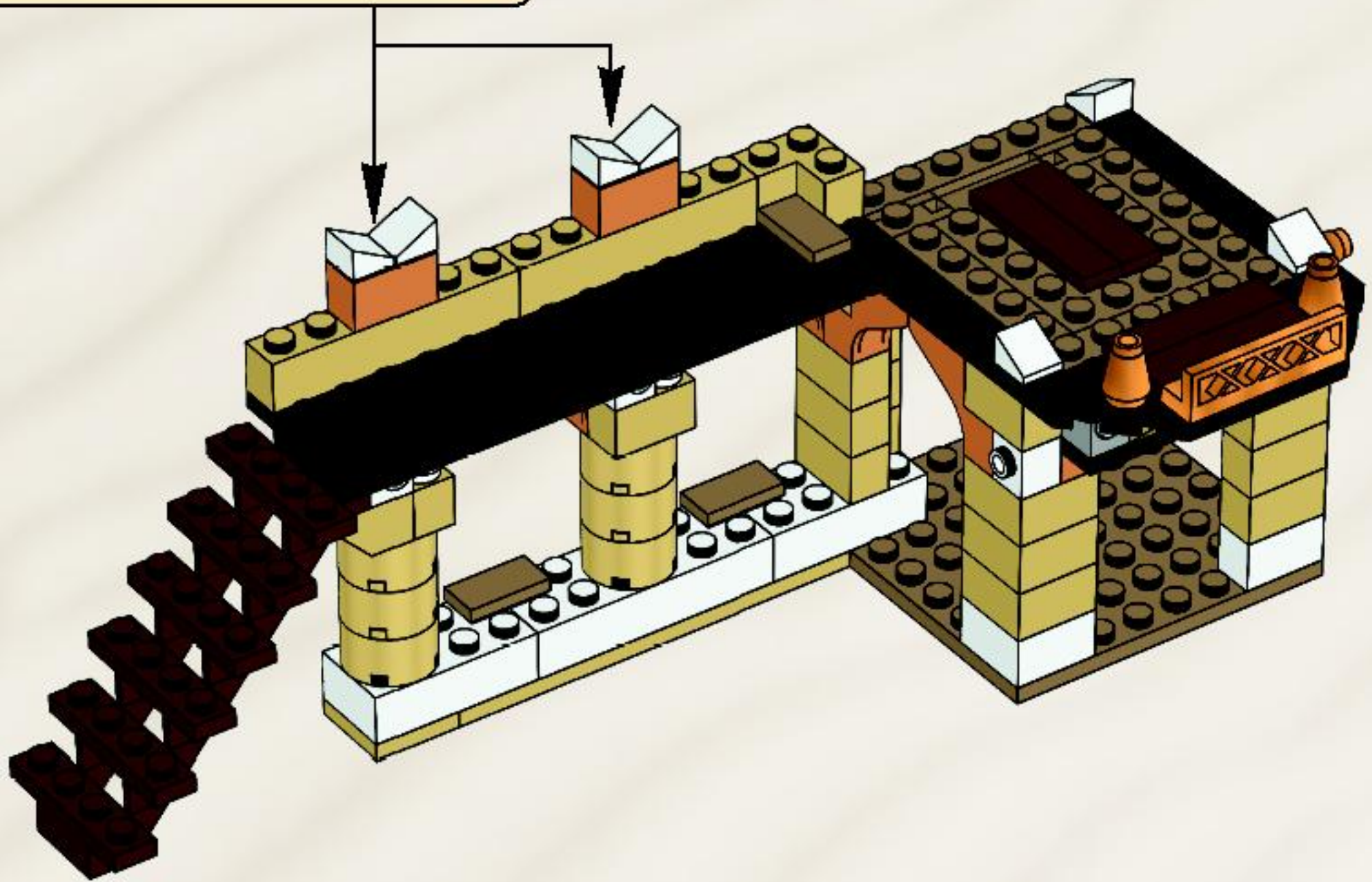
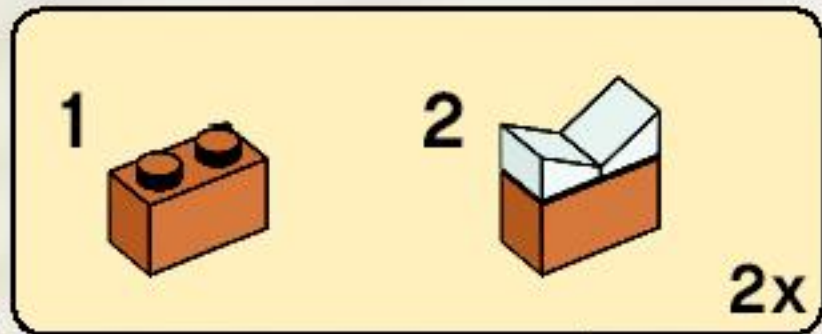



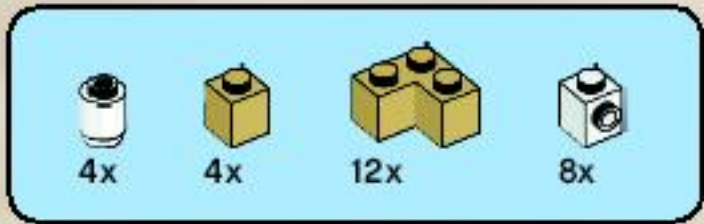

26

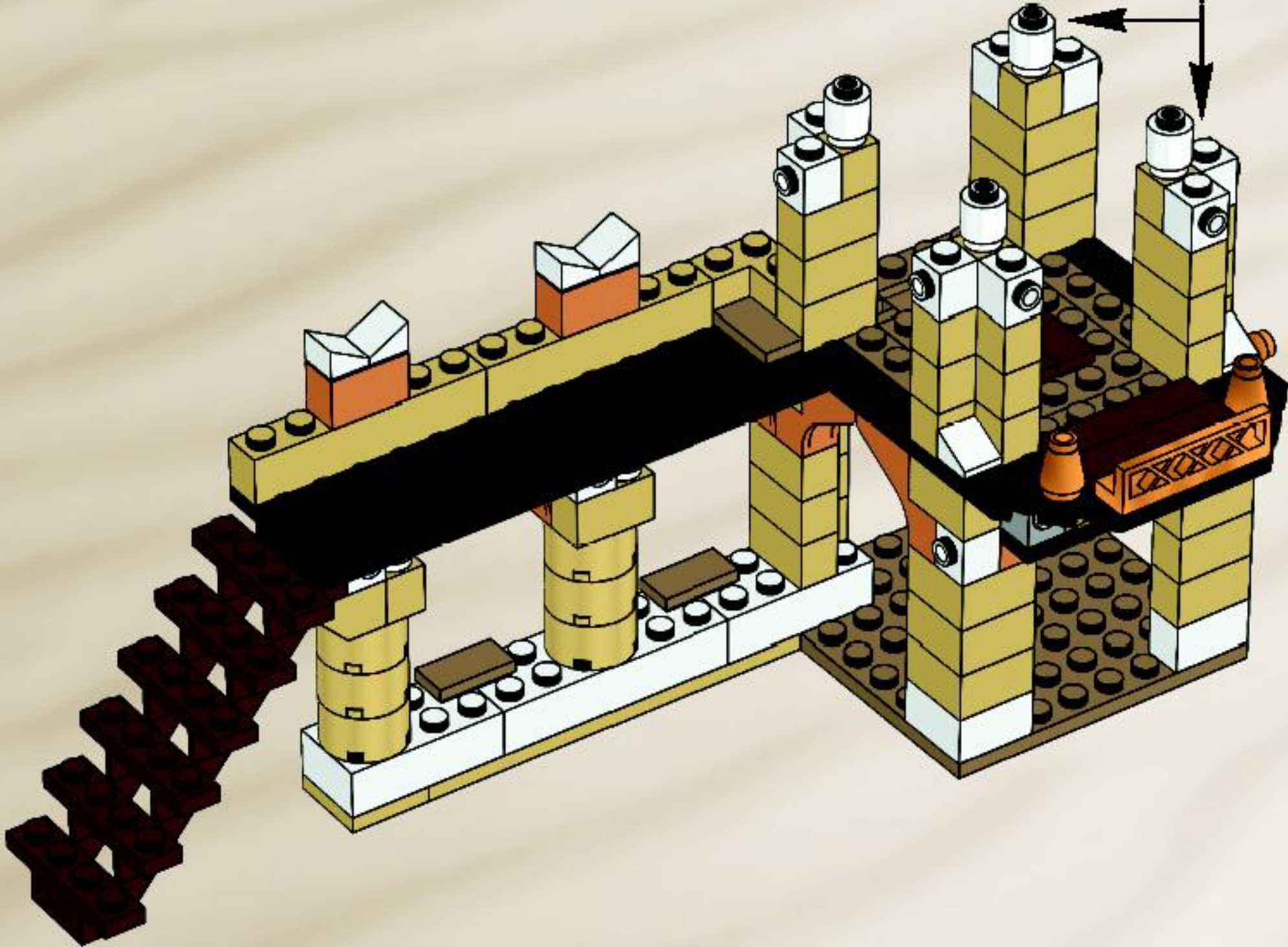
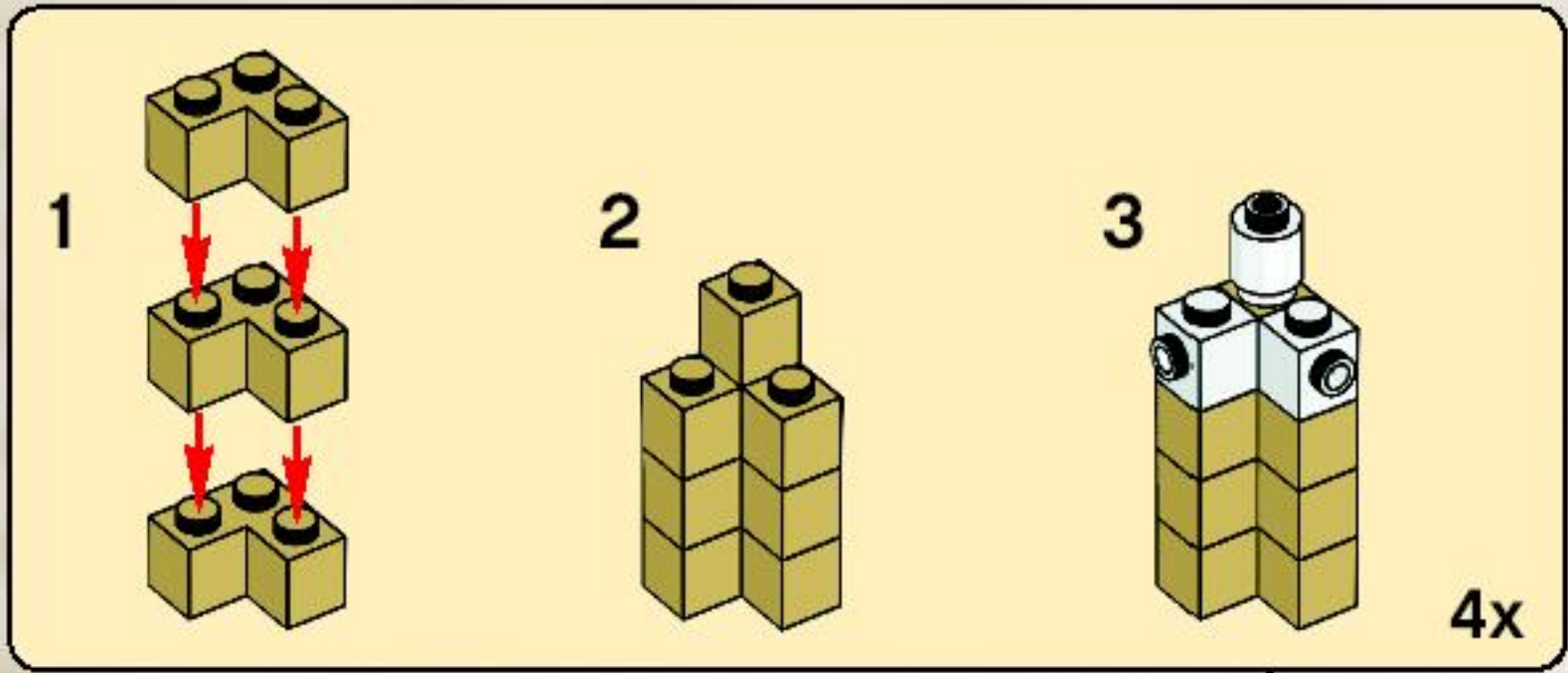



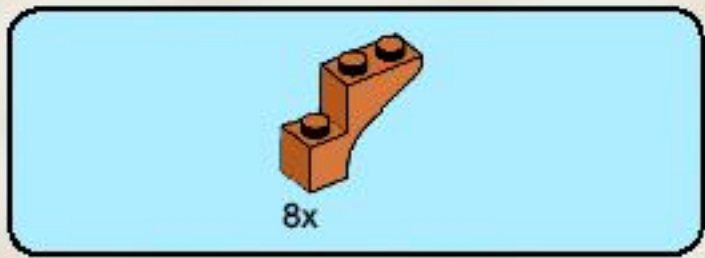

27

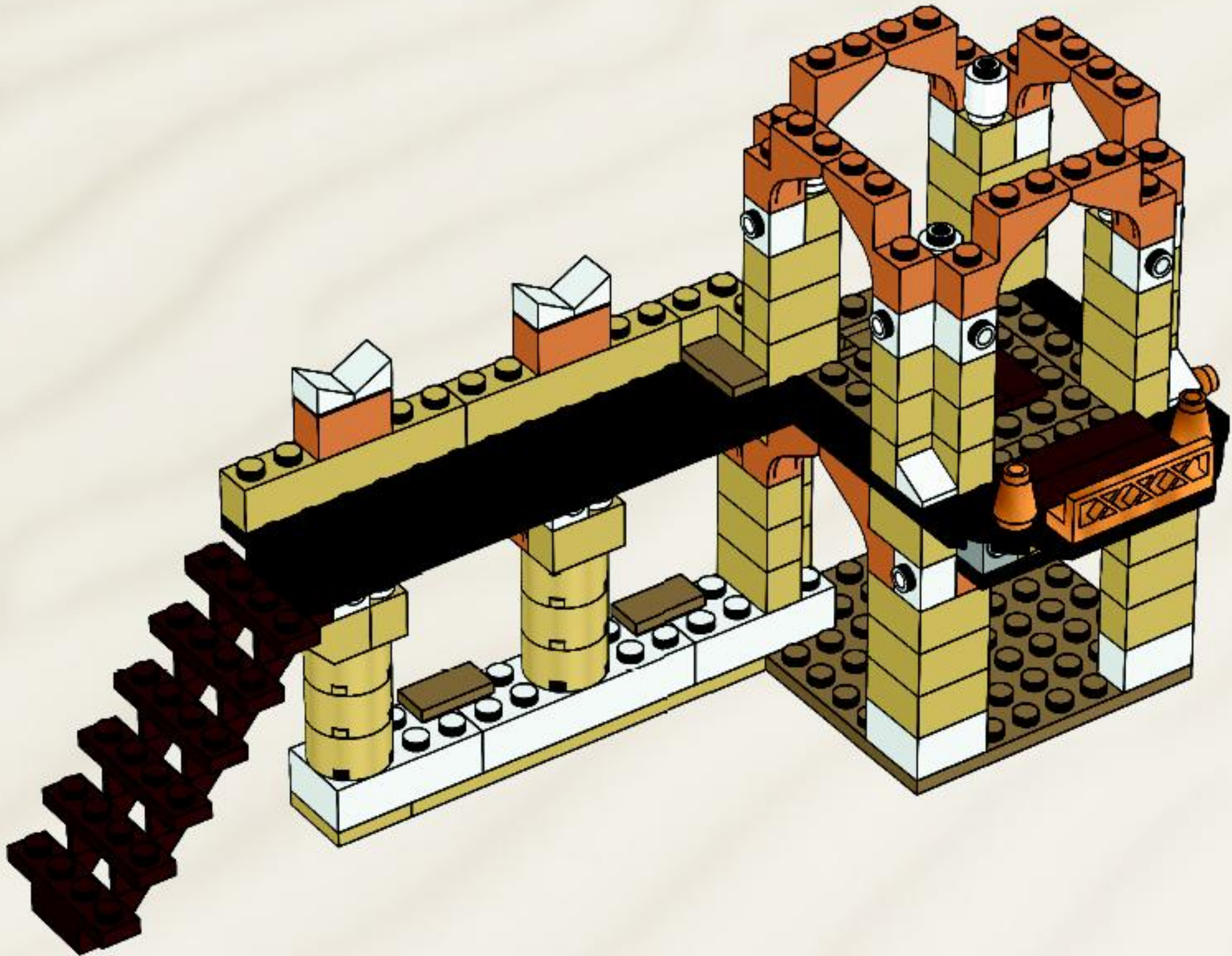





4x

28

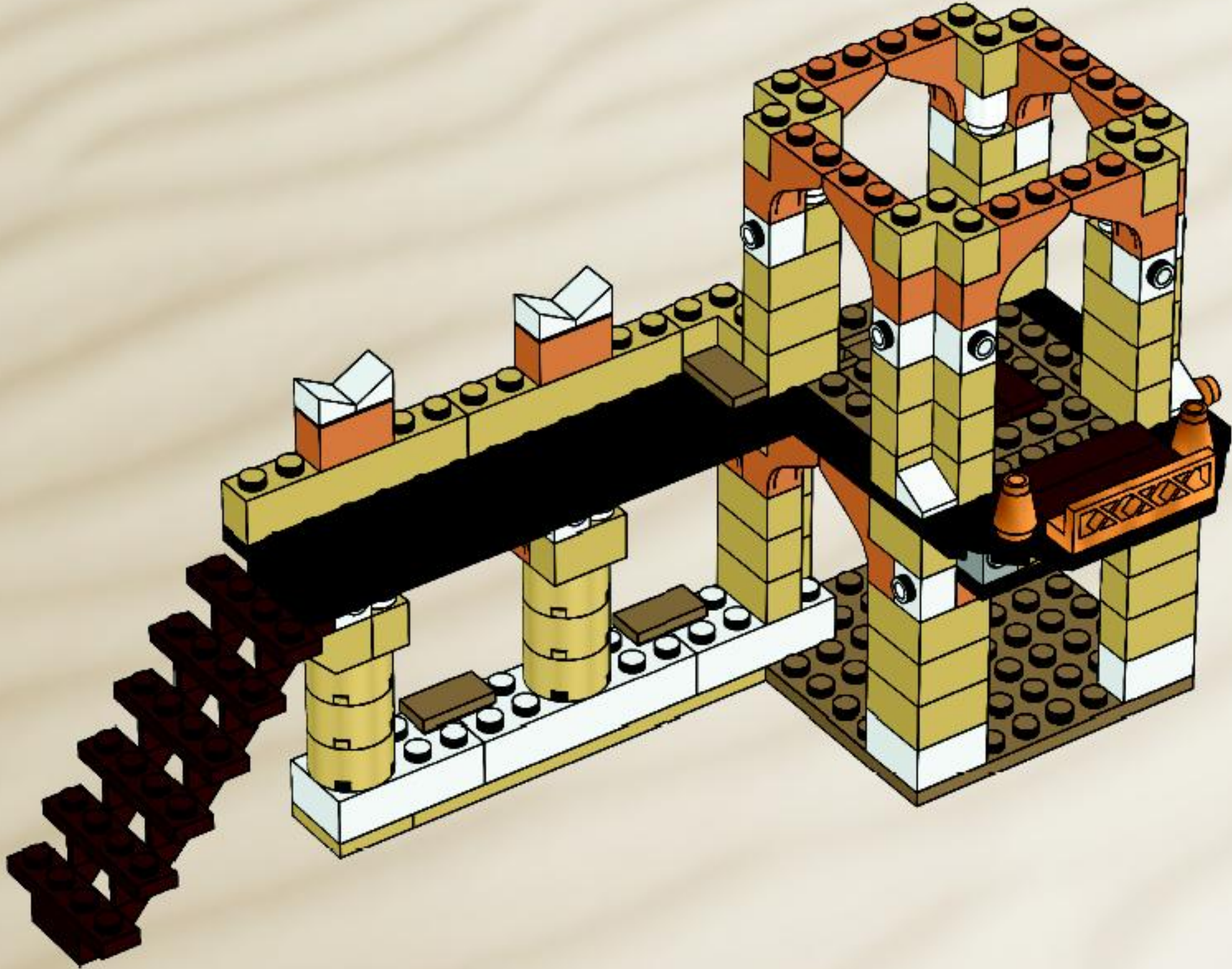



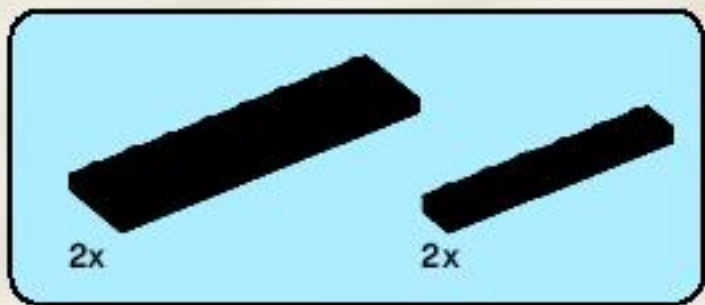

29

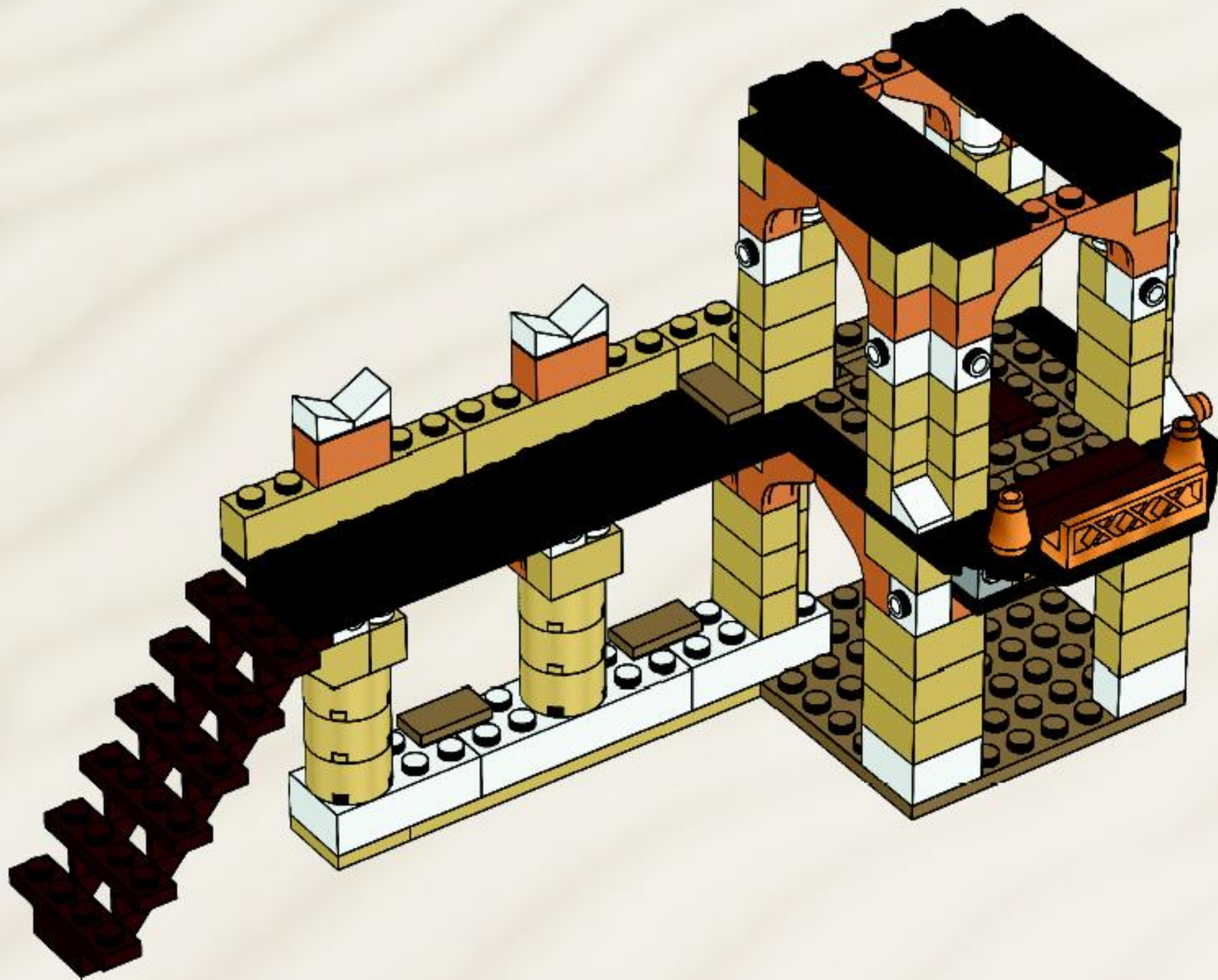



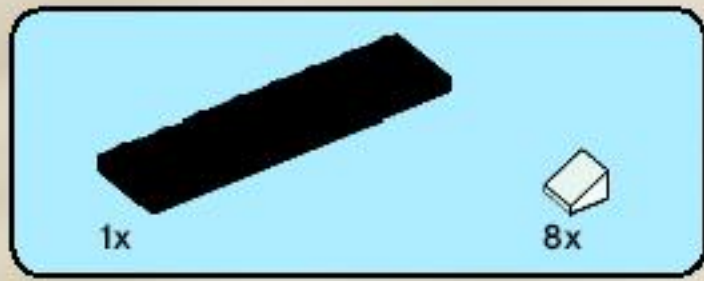

30

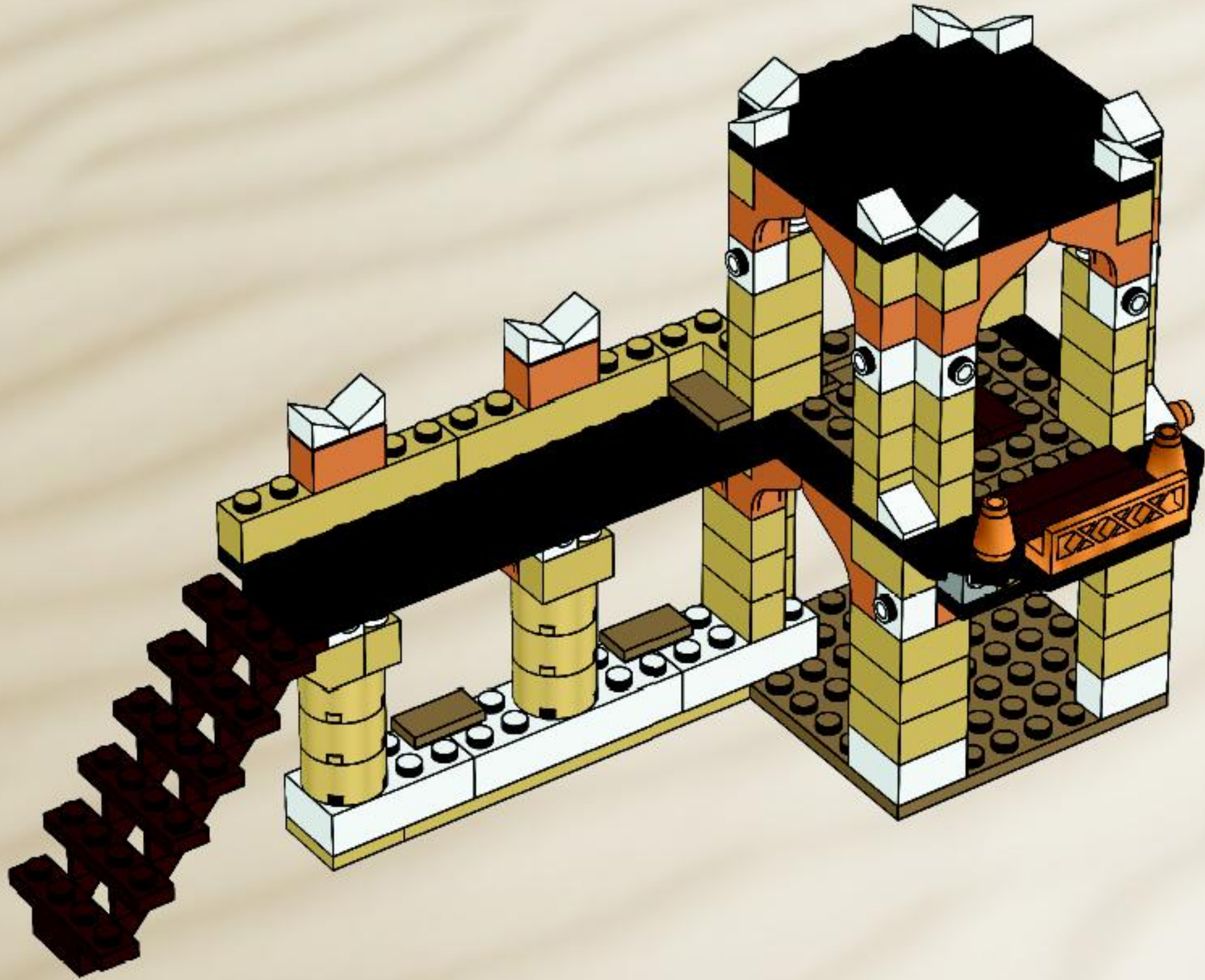



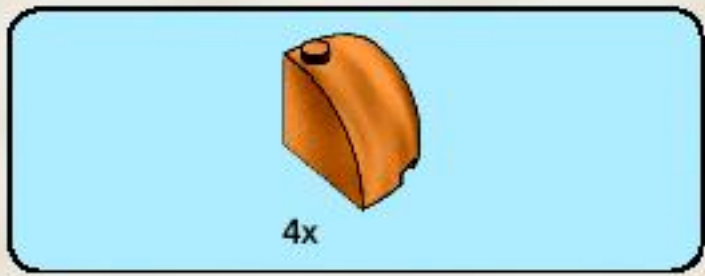

31

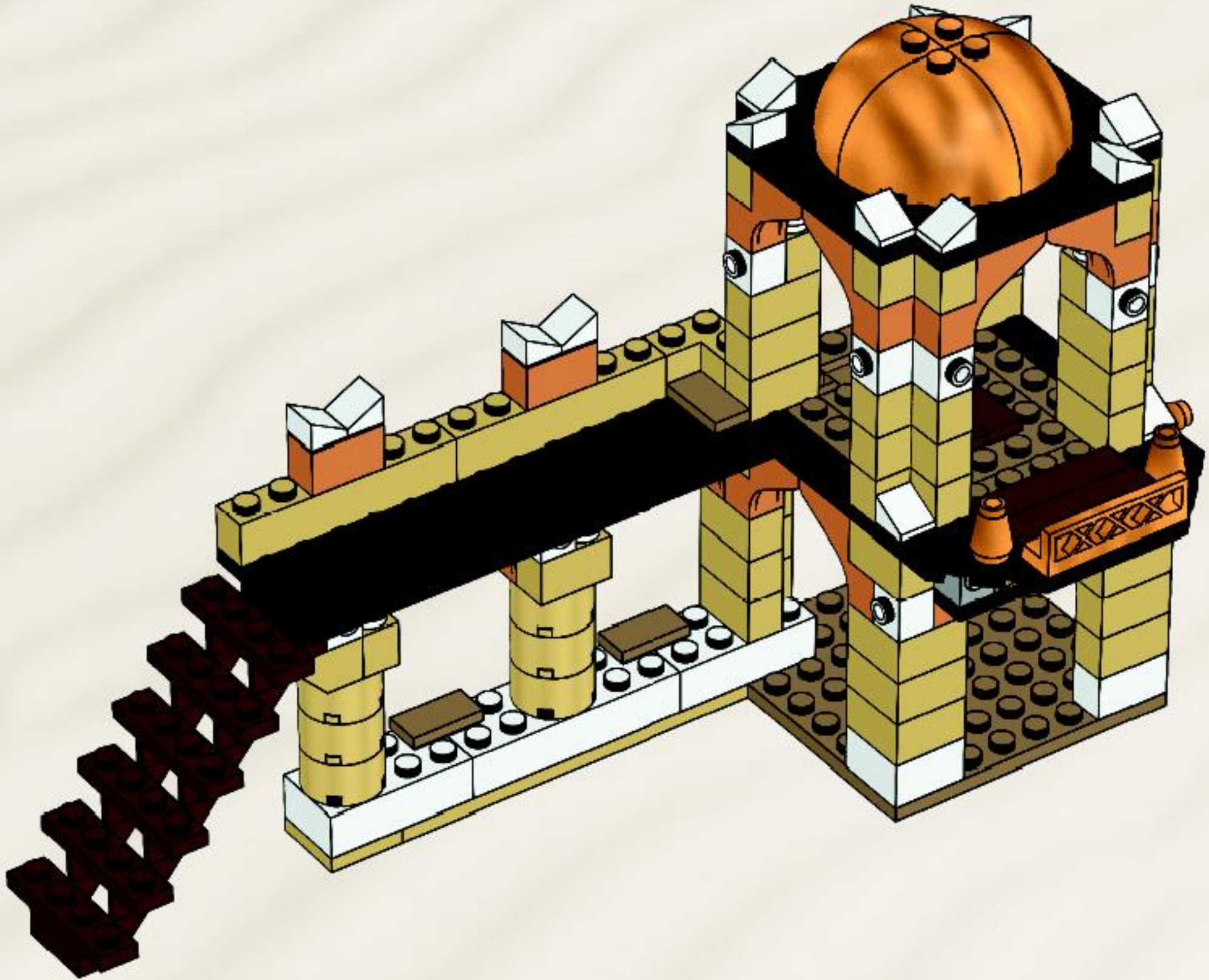





32

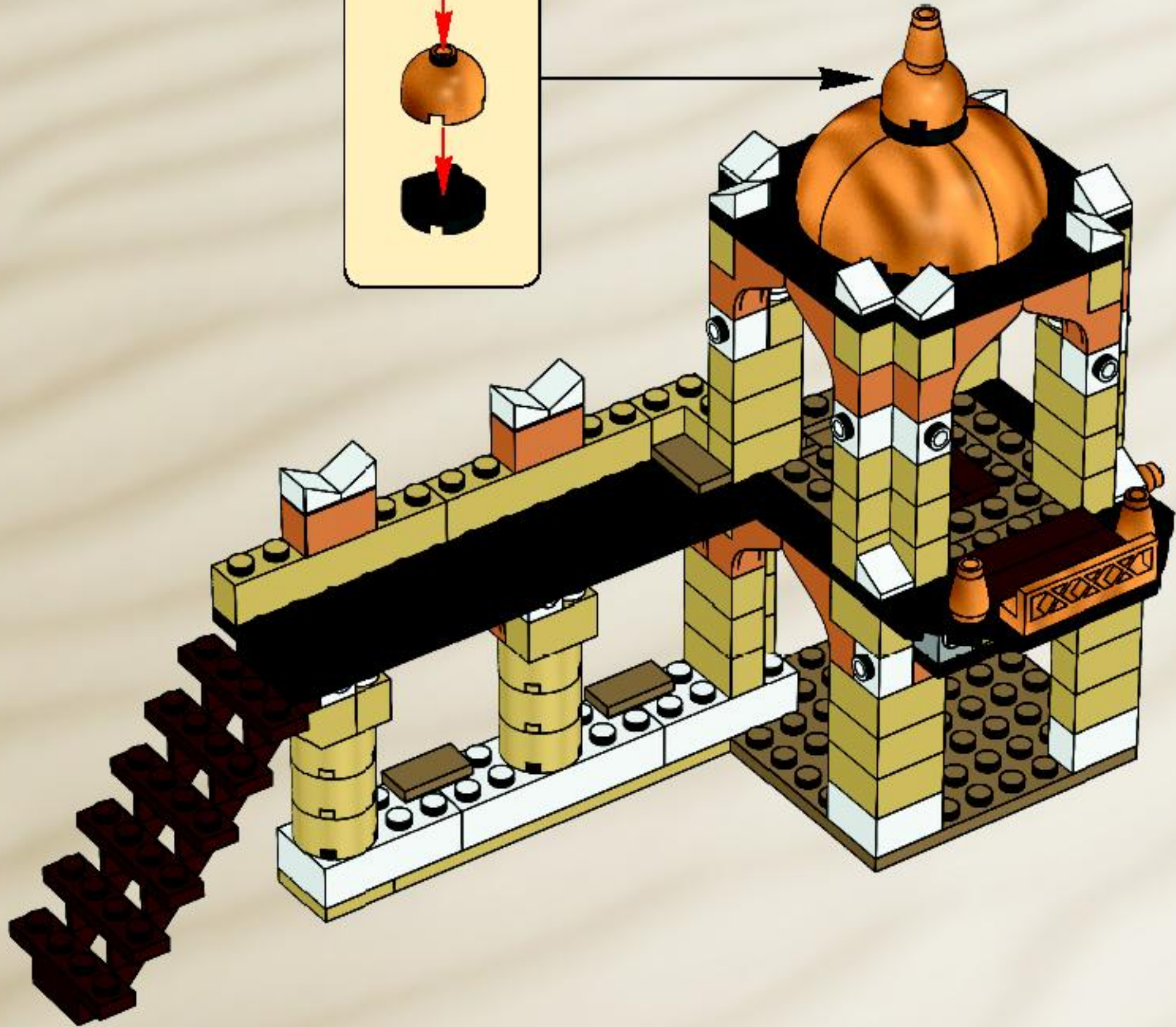
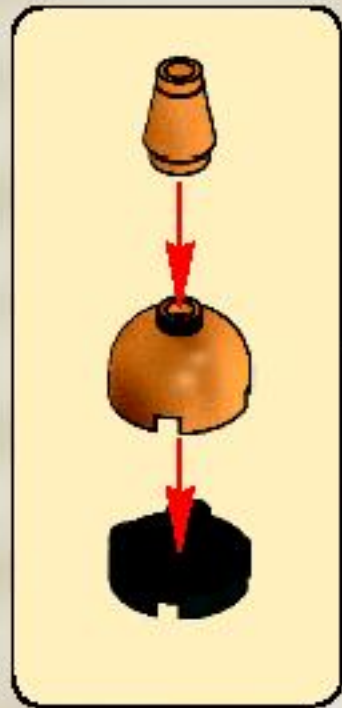



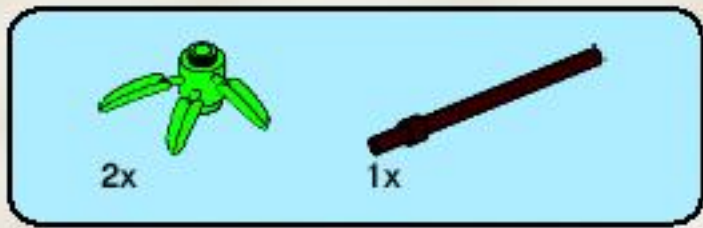

33

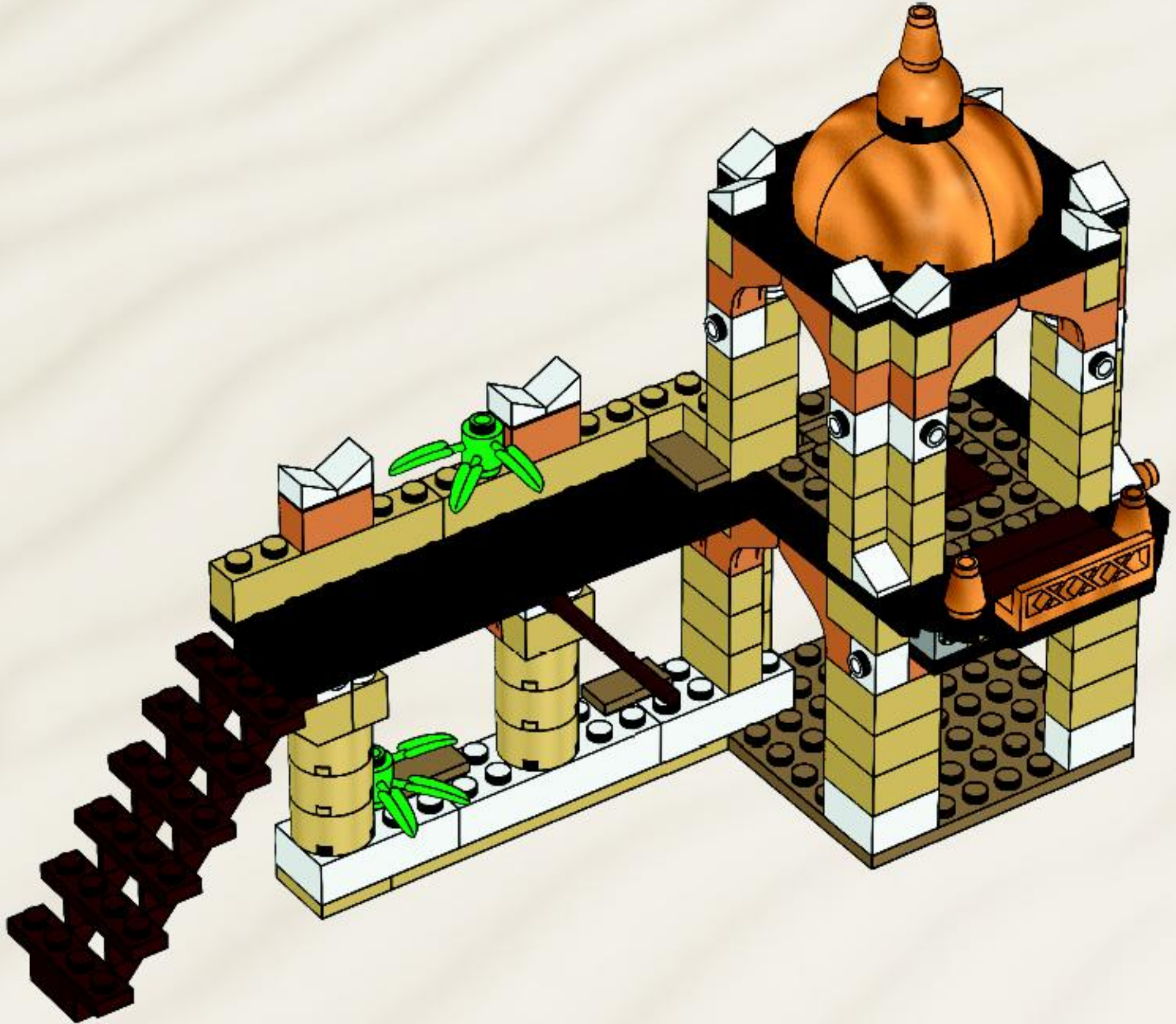





34

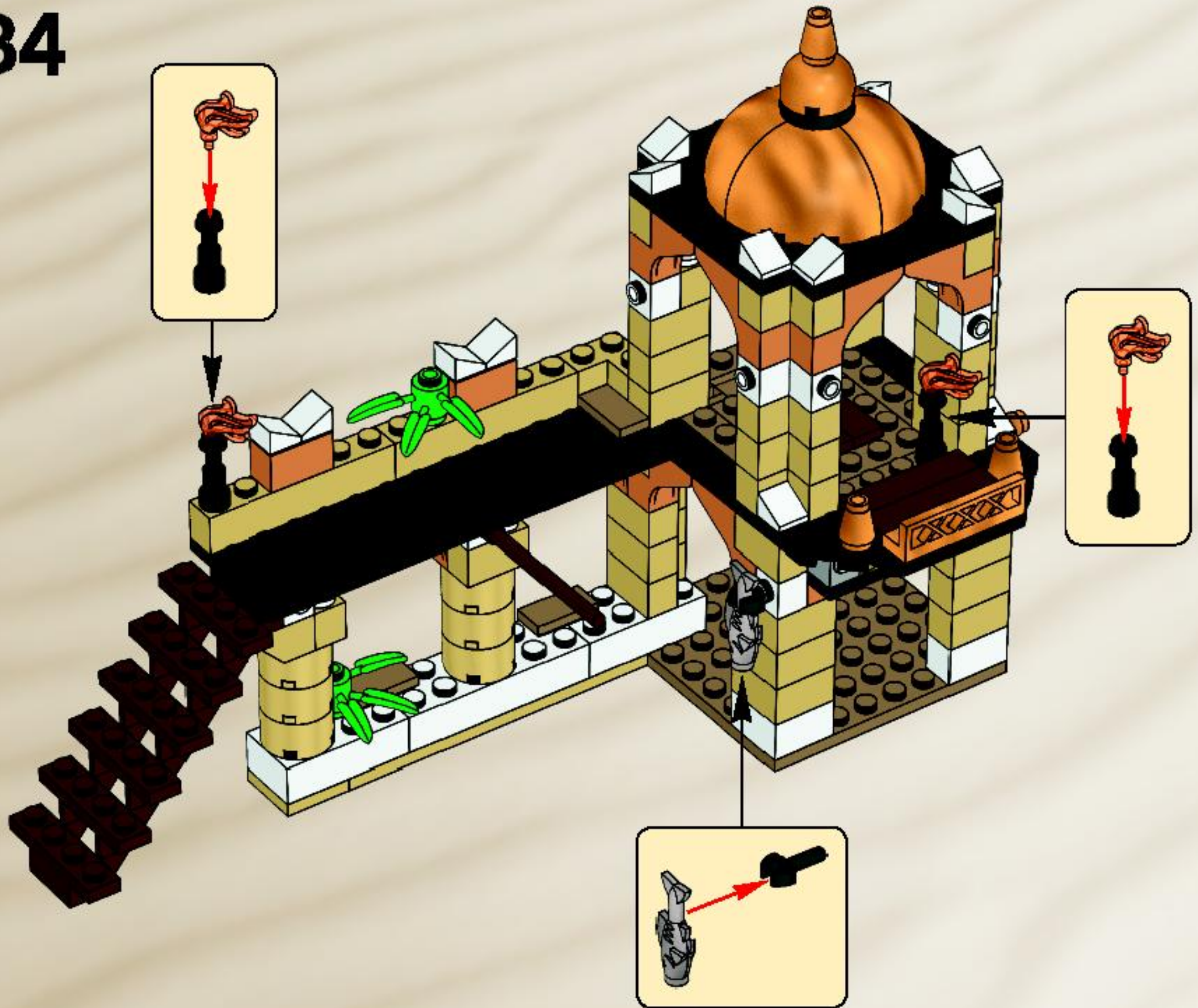



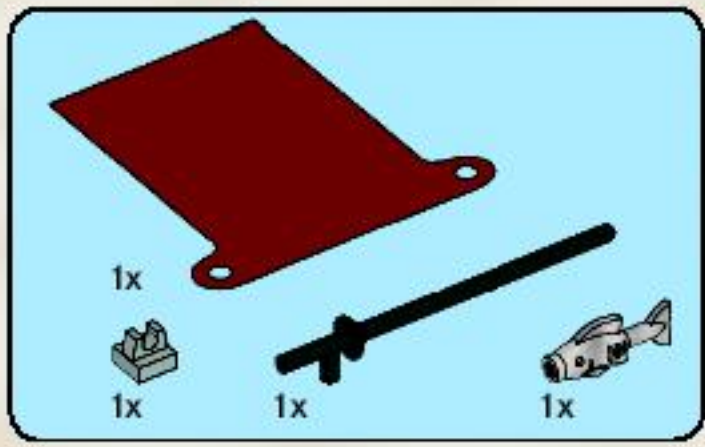

35

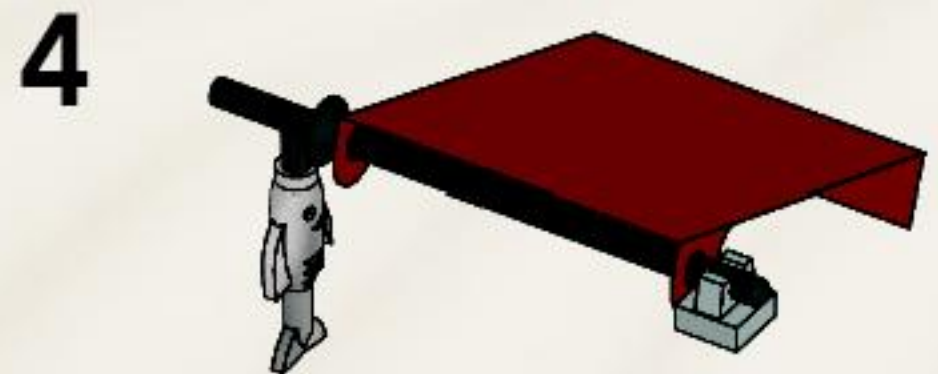
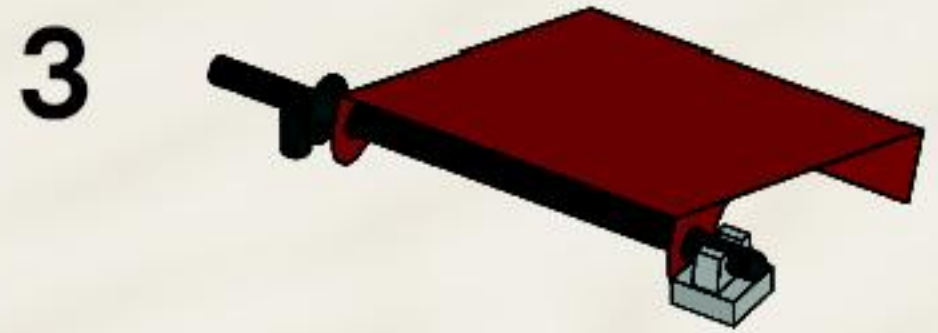
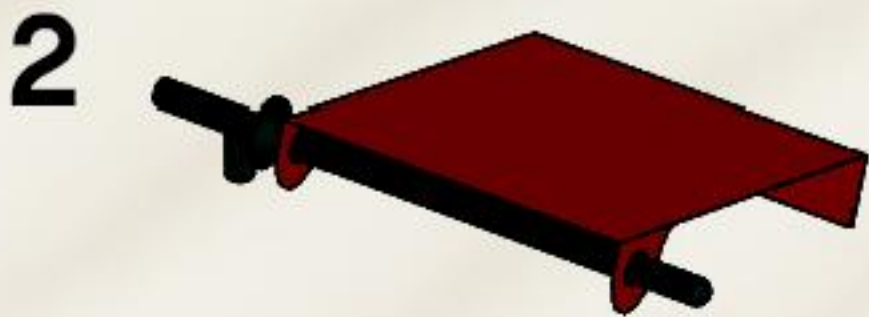

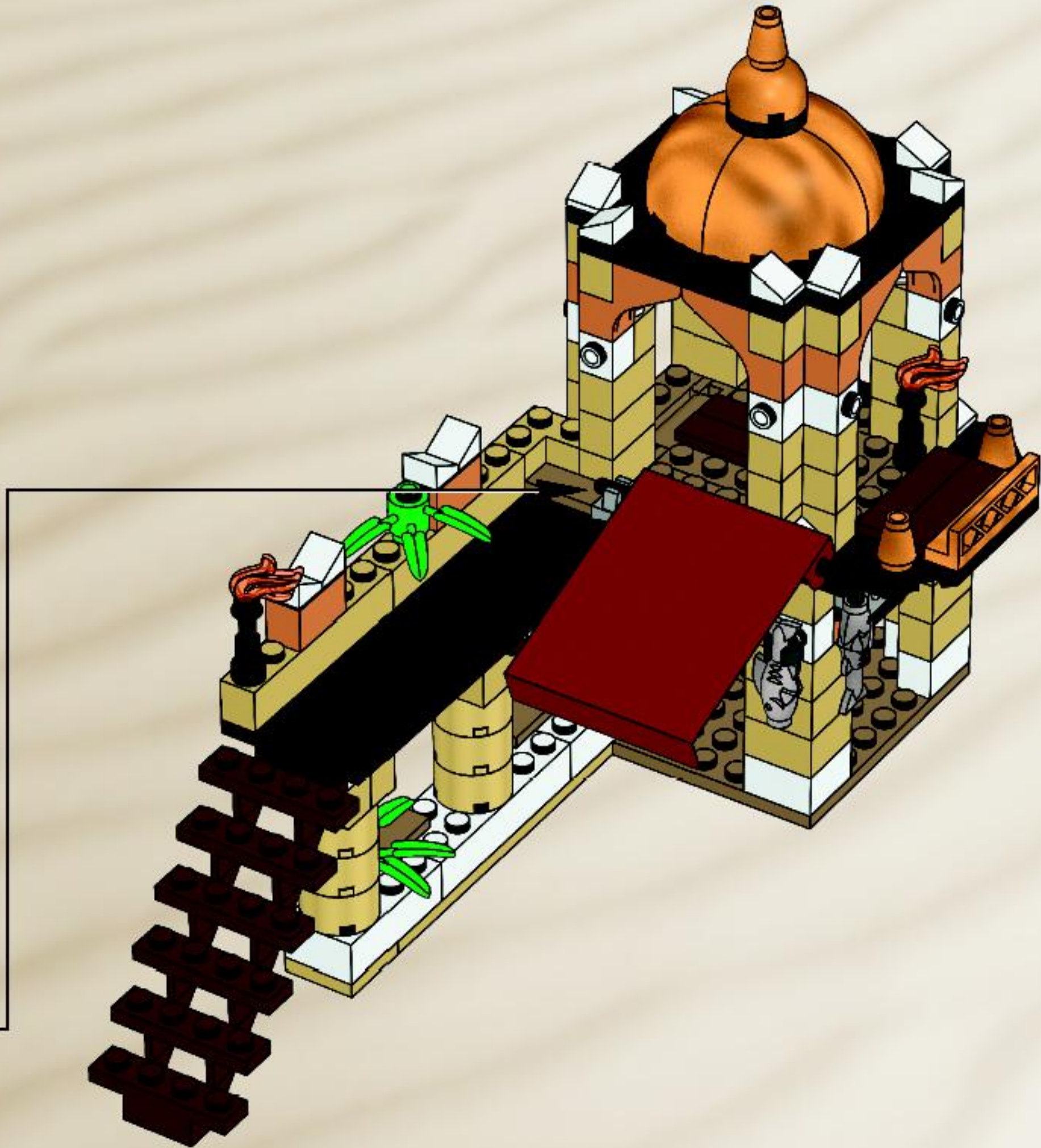













Customer Service  
 Kundenservice  
 Service Consommateurs  
 Servicio Al Consumidor

[www.lego.com/service](http://www.lego.com/service) or dial





FREE! GRATIS! GRATUIT!



club MAGAZINE™

www.LEGOclub.com



00800 5346 5555\*

1-866-534-6258 • 1-877-518-5346  
US & Canada only Canada seulement



VISIT THE WORLD'S  
BIGGEST LEGO® SHOP!

www.LEGOshop.com

\* Free phone. Mobile charges may apply. \* Numéro sans frais. Des frais peuvent s'appliquer avec les téléphones cellulaires. \* GelöörntFrei, Kosten für Anrufe aus Mobilfunknetzen können anfallen. \* Gratis telefonnummer vanaf vaste lijn. \* Deter ett gratis nummer, när du ringer från fasttelefon. \* Det är gratis, när du ringer från en fast telefon.





7569



7570



7571



7573





# WIN!

Go to [www.nielsen.com/LEGO](http://www.nielsen.com/LEGO)  
to fill out a survey for a chance  
to win a cool LEGO® Product.  
No purchase necessary.  
Open to all residents where not prohibited.



## [www.nielsen.com/LEGO](http://www.nielsen.com/LEGO)

### GEWINNE! WIN!

Nimm an der Umfrage auf  
[www.nielsen.com/LEGO](http://www.nielsen.com/LEGO)  
teil und hab die Chance ein cooles  
LEGO® Produkt zu gewinnen!

Die Teilnahme am Gewinnspiel führt zu keinerlei  
Kaufverpflichtungen. Teilnahme in allen nicht  
ausgeschlossenen Ländern möglich.

Ga naar [www.nielsen.com/LEGO](http://www.nielsen.com/LEGO),  
vul een enquêteformulier in en  
maak kans op een  
cool LEGO® product.

Geen aankoopverplichting.  
Iedereen mag deelnemen, uitgezonderd  
Ingezetenden  
van landen waar een enquêteverbod geldt.

### GAGNE! 当てよう!

Visite [www.nielsen.com/LEGO](http://www.nielsen.com/LEGO)  
pour répondre à un questionnaire  
et avoir une chance de gagner  
un produit LEGO® très cool!

Aucune obligation d'achat.  
Ouvert à tous les résidents des pays  
autorisés.

[www.nielsen.com/LEGO](http://www.nielsen.com/LEGO)にアクセスして、アンケ  
ートにご記入ください。当選者にはレゴ製品を  
差し上げます。

お買い上げの必要はありません。

禁止されていない限り、すべての年齢にご利用いただけます。