



# ISLAND XTREME STUNTS



6738

4173675



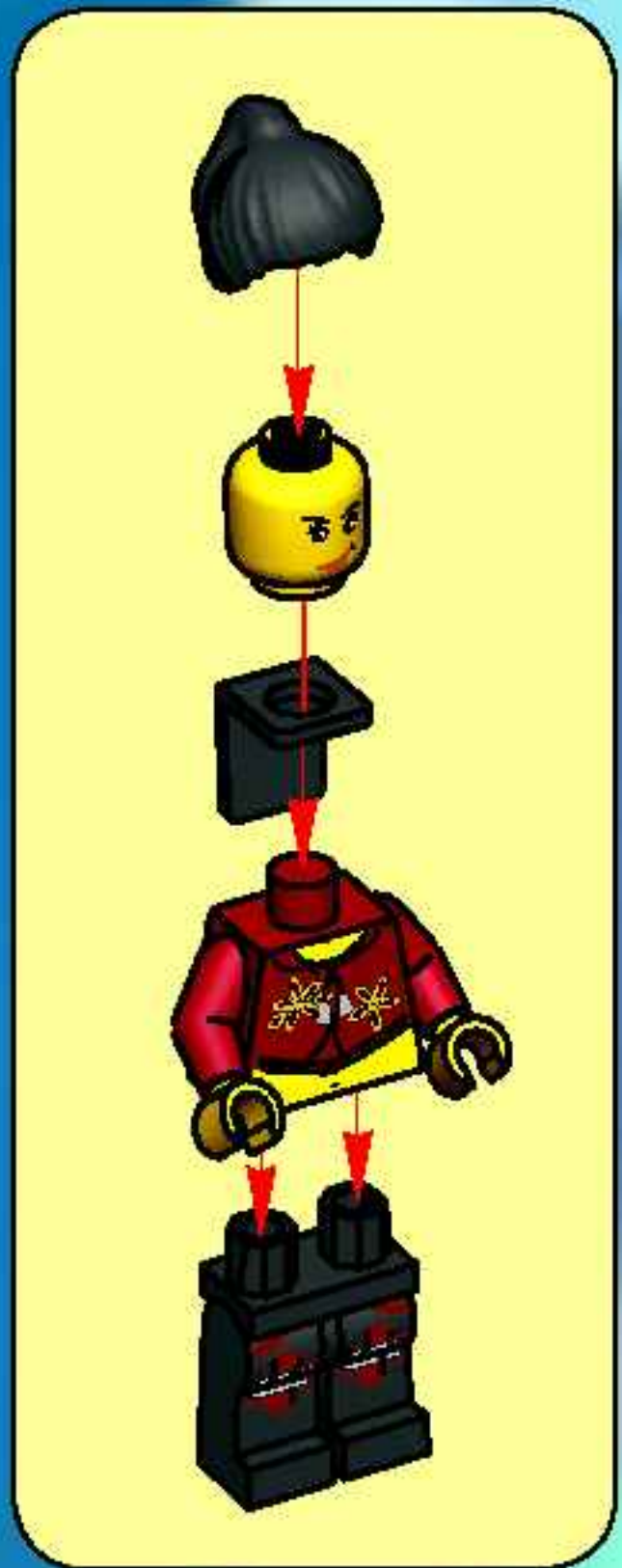

1



2

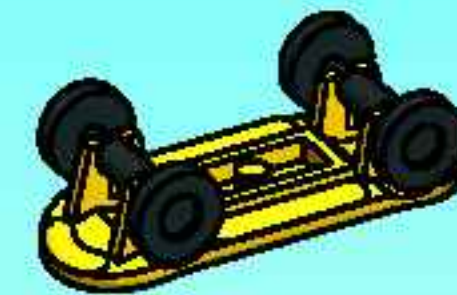

3



4







1



2



3



4



1



2

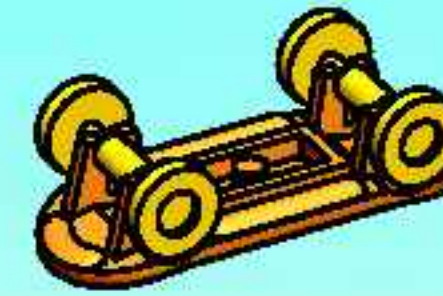

3



4





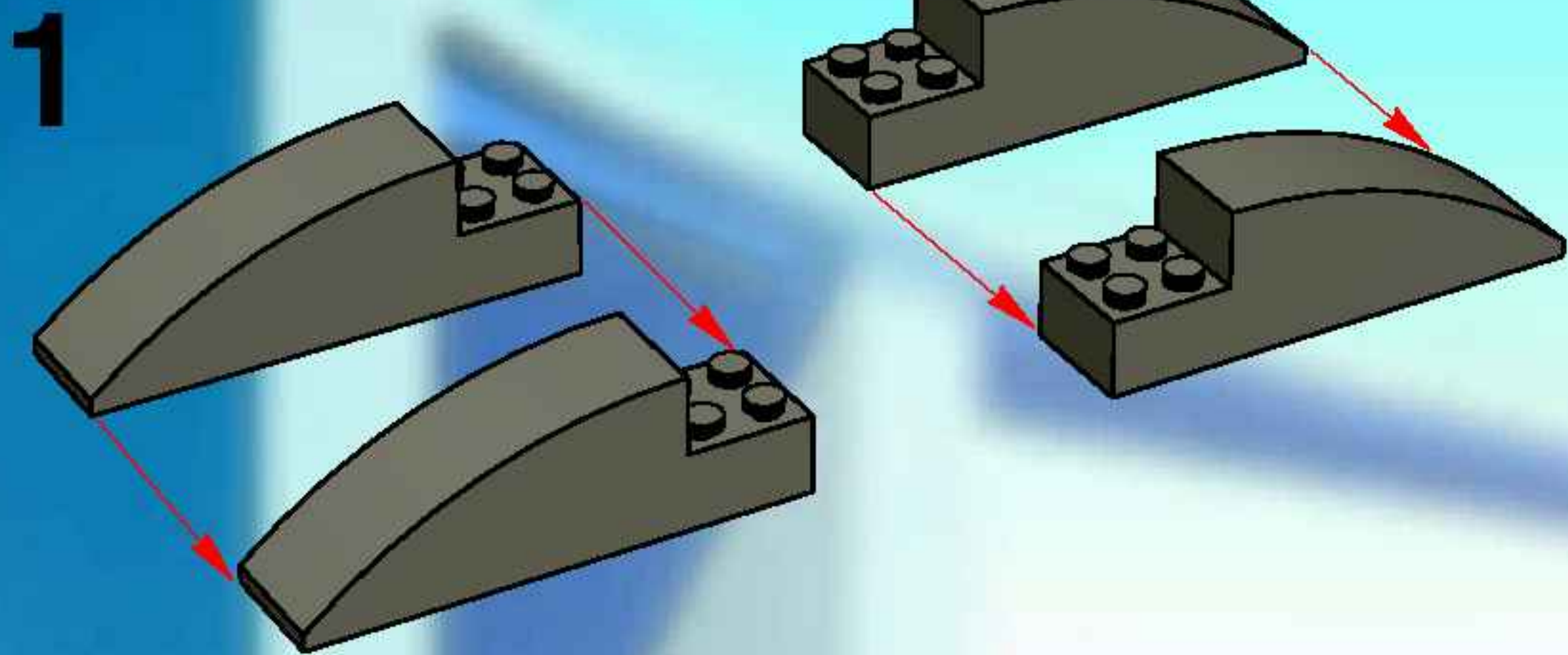
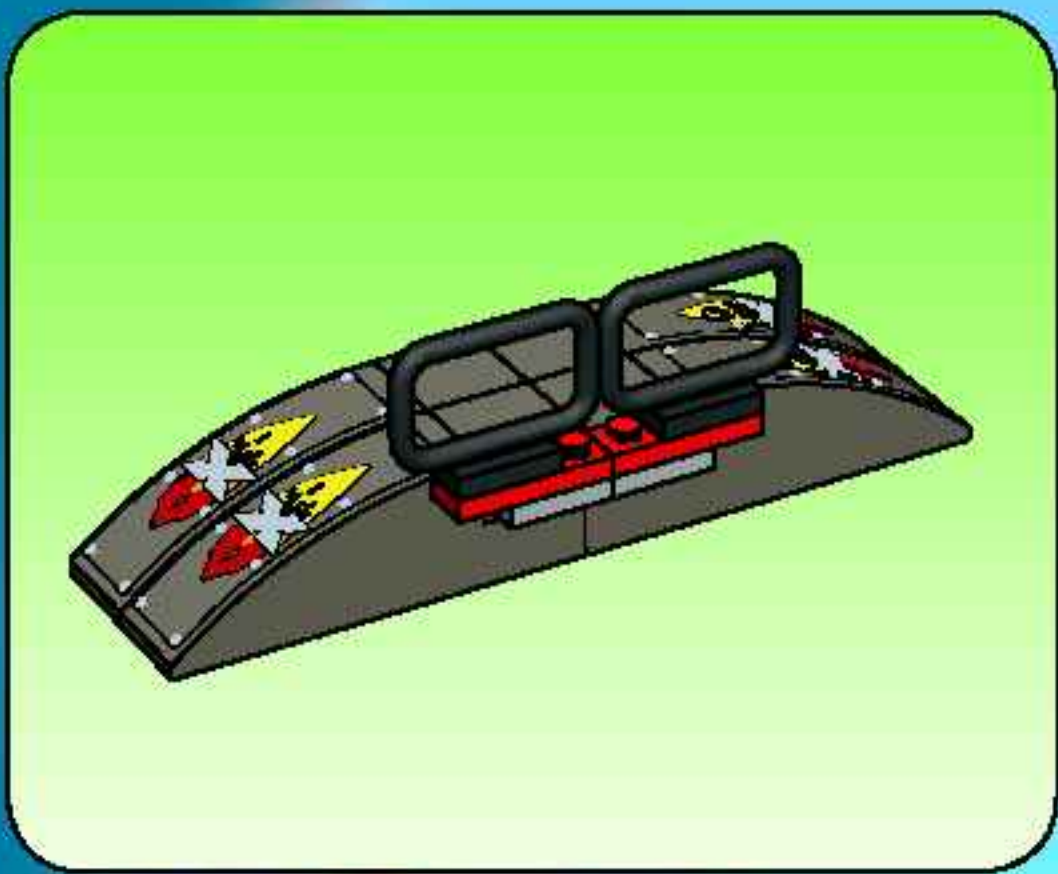

**2**

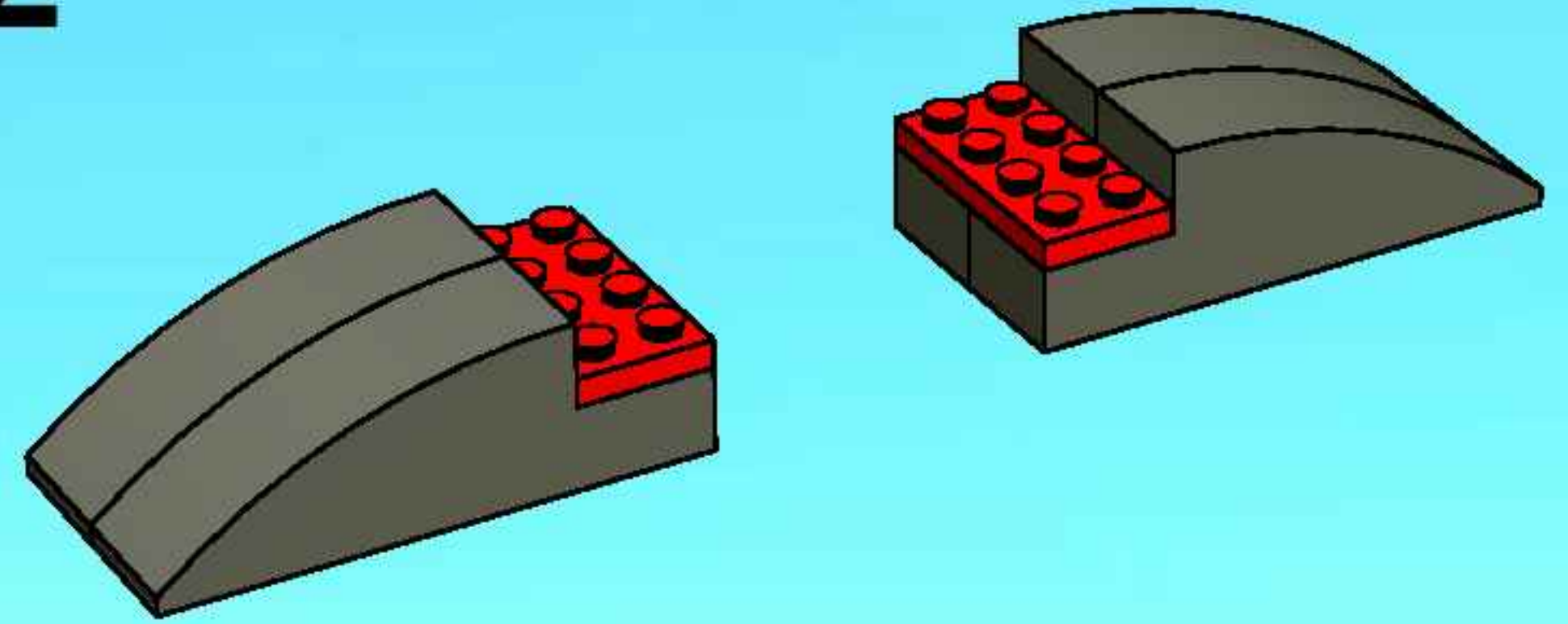

**3**

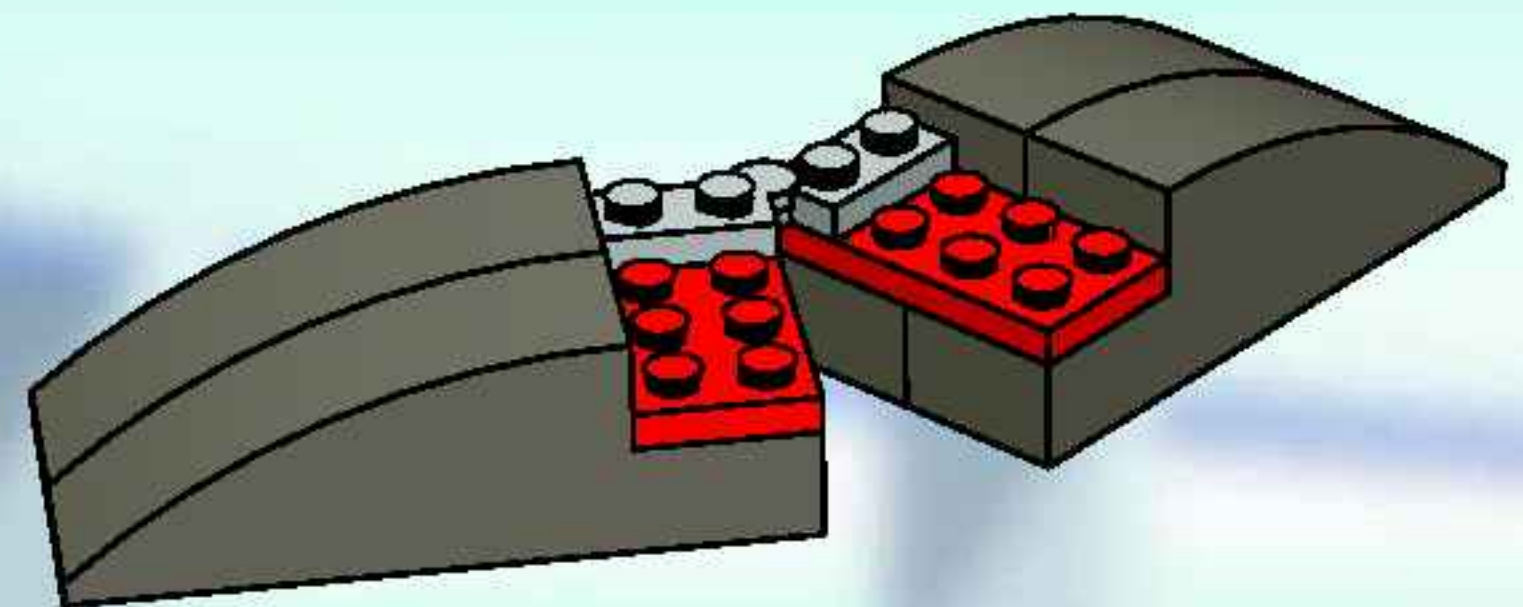



4

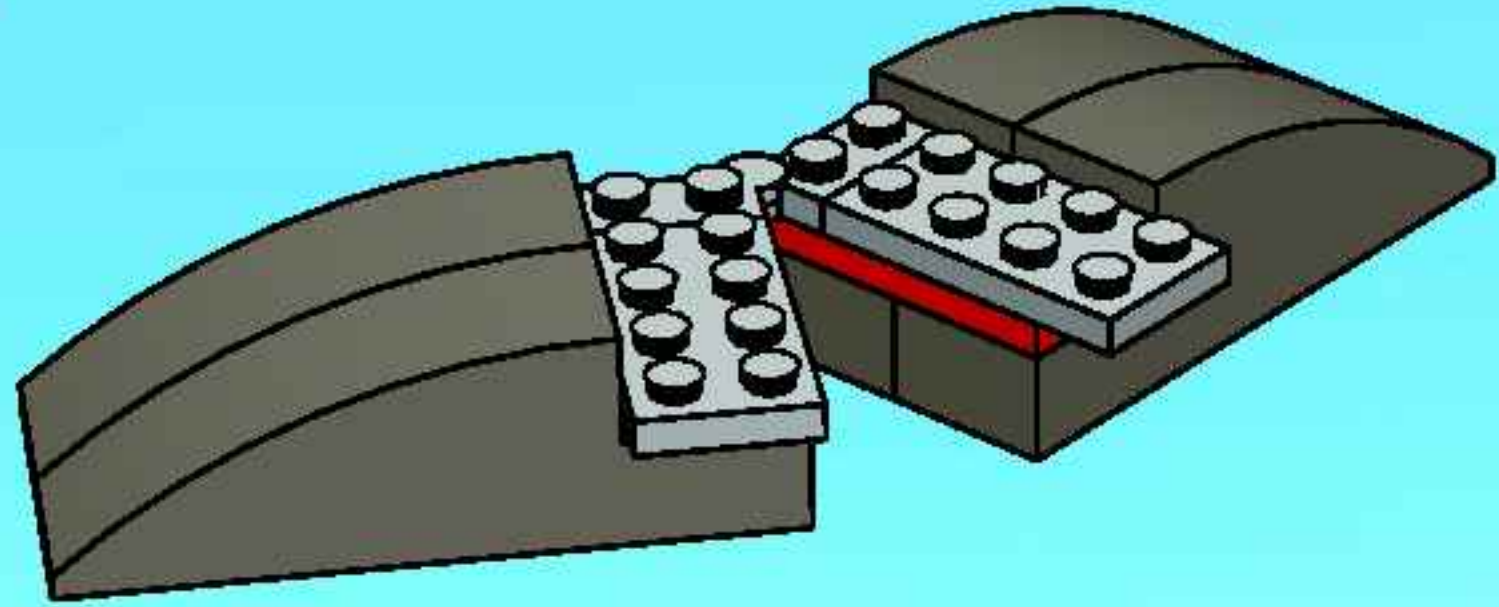

5

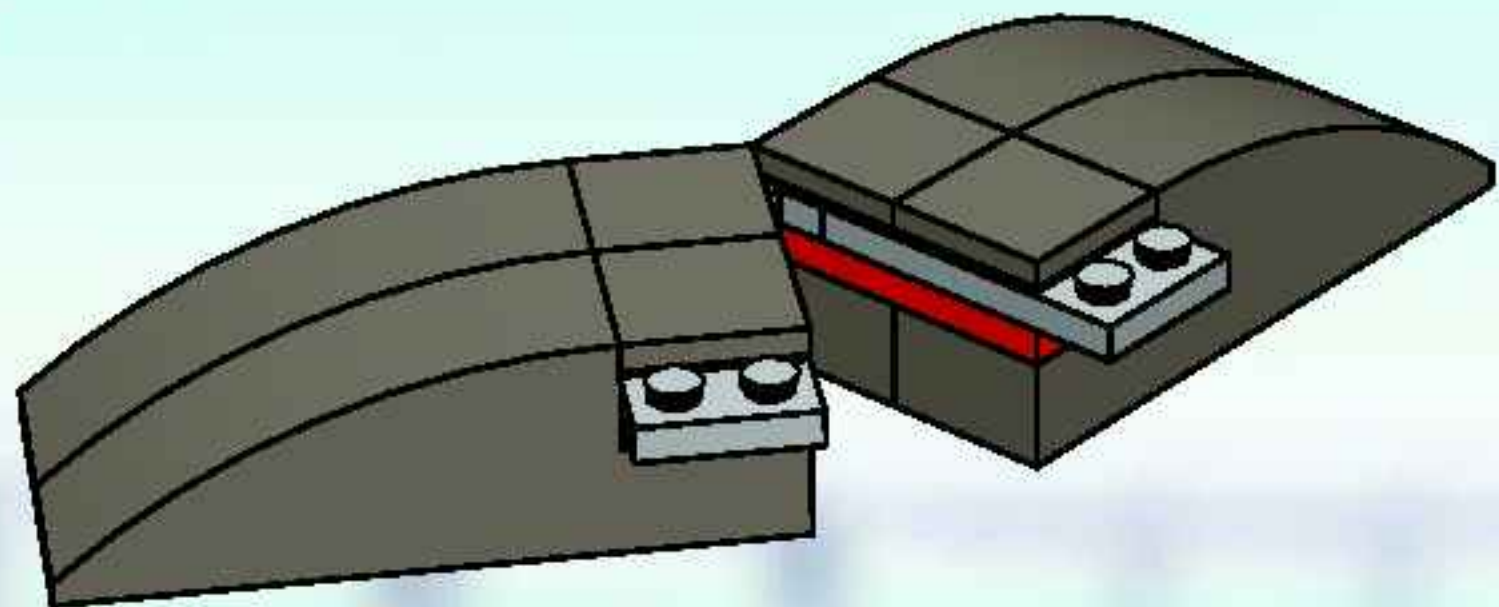

6

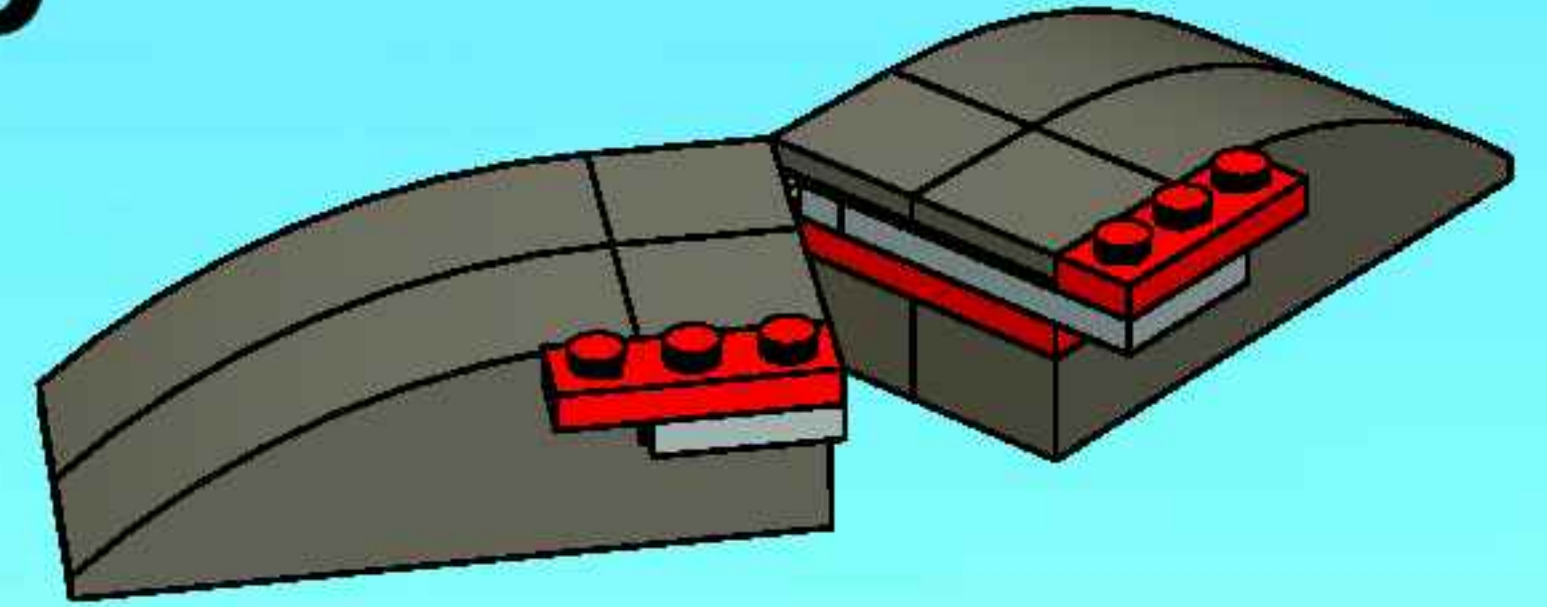

7

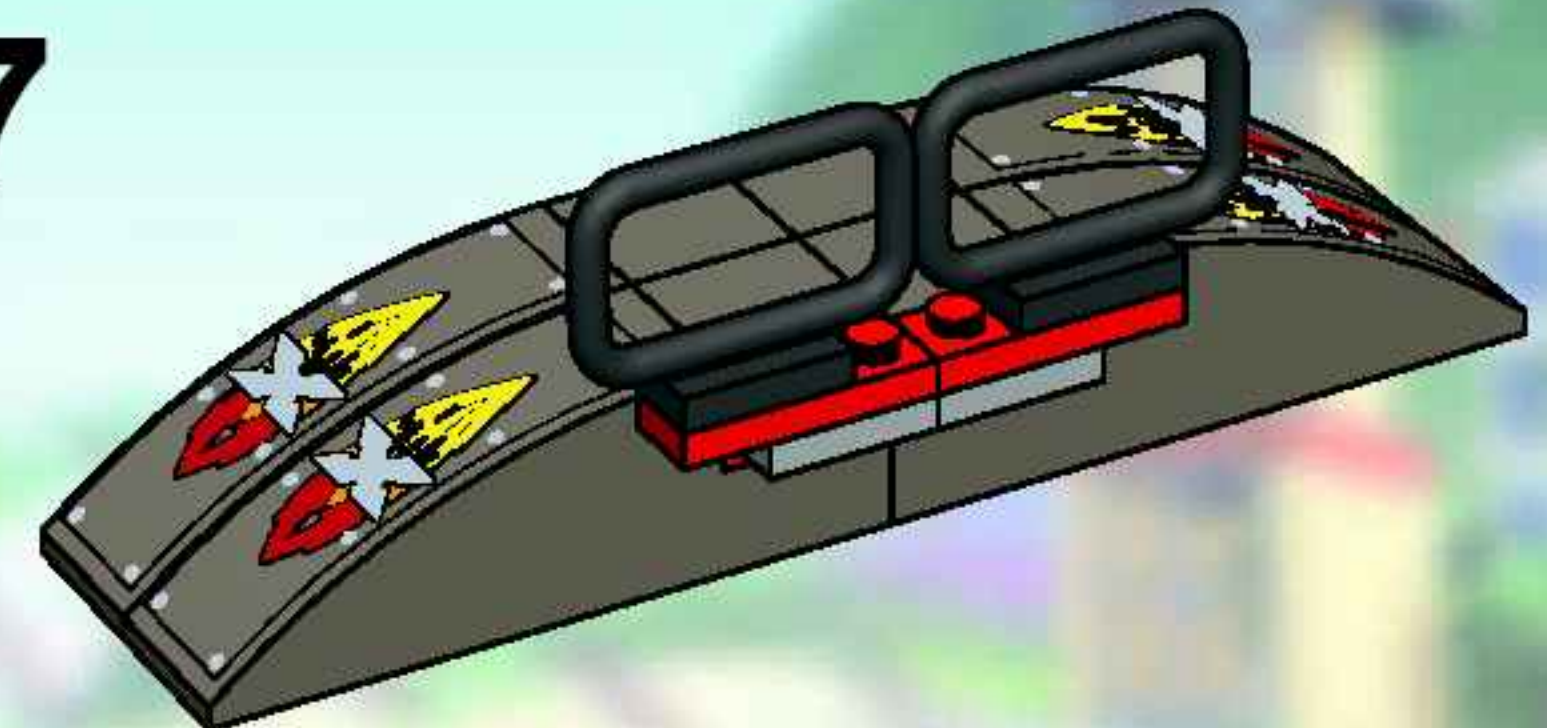



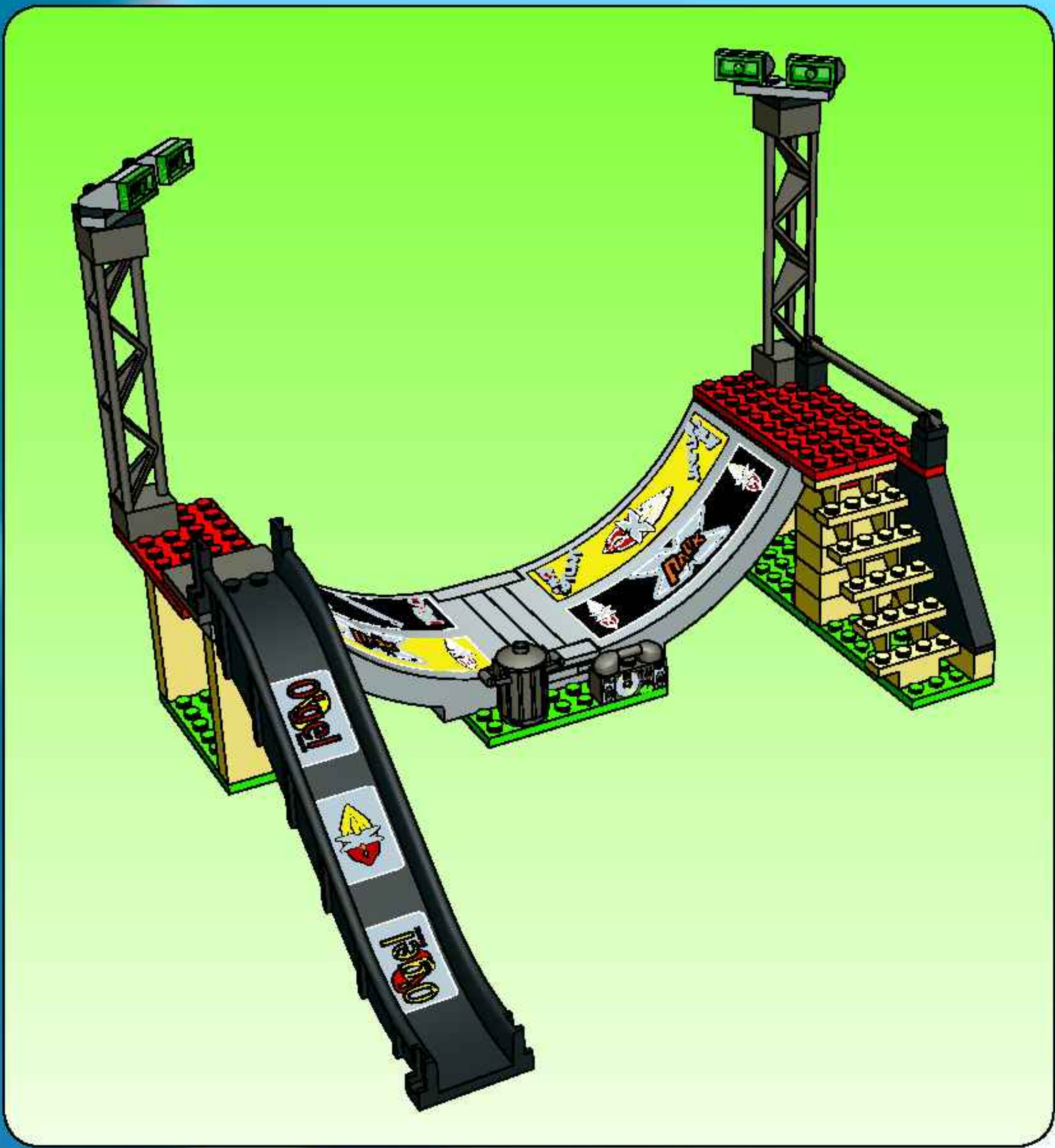

1

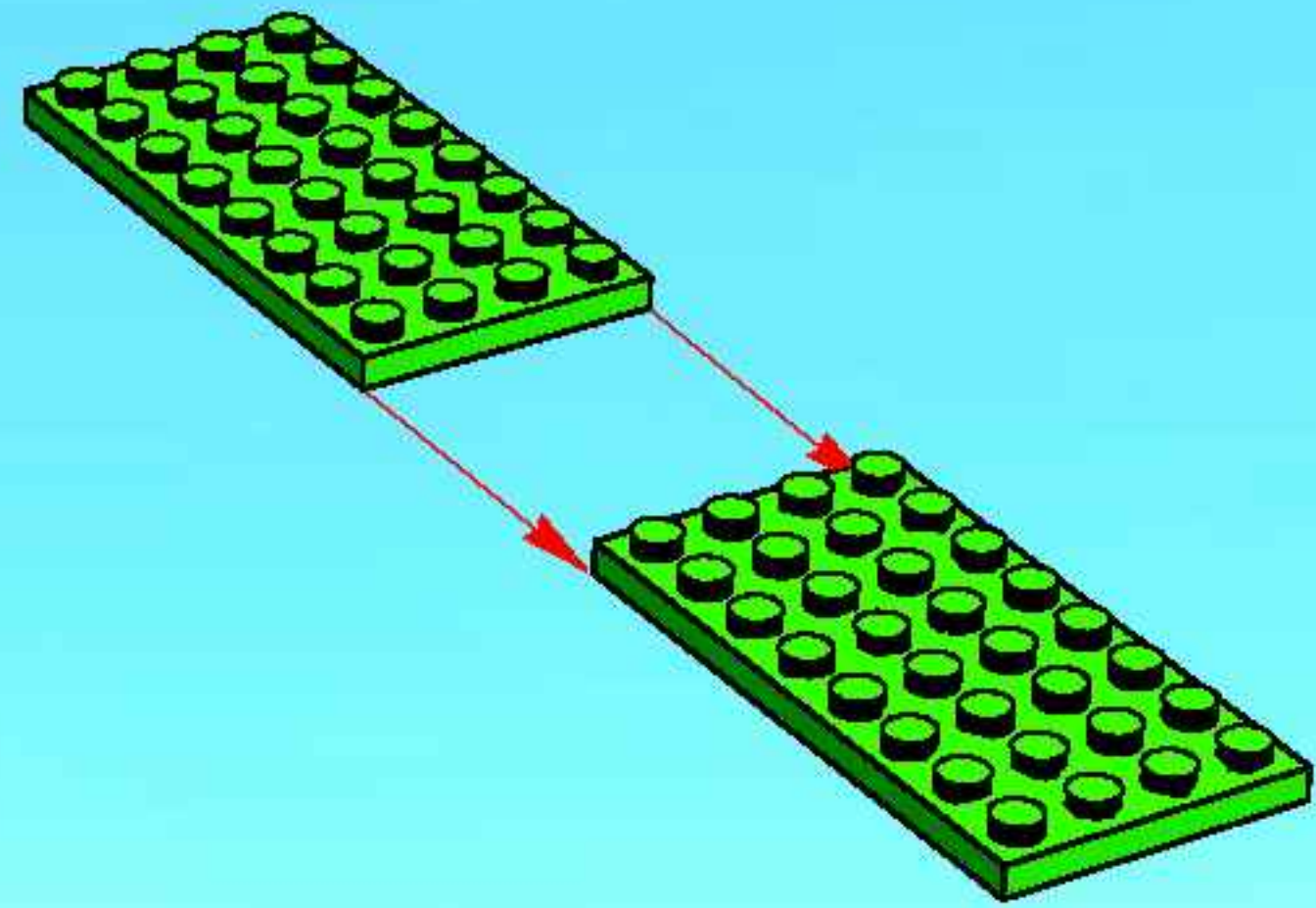

2

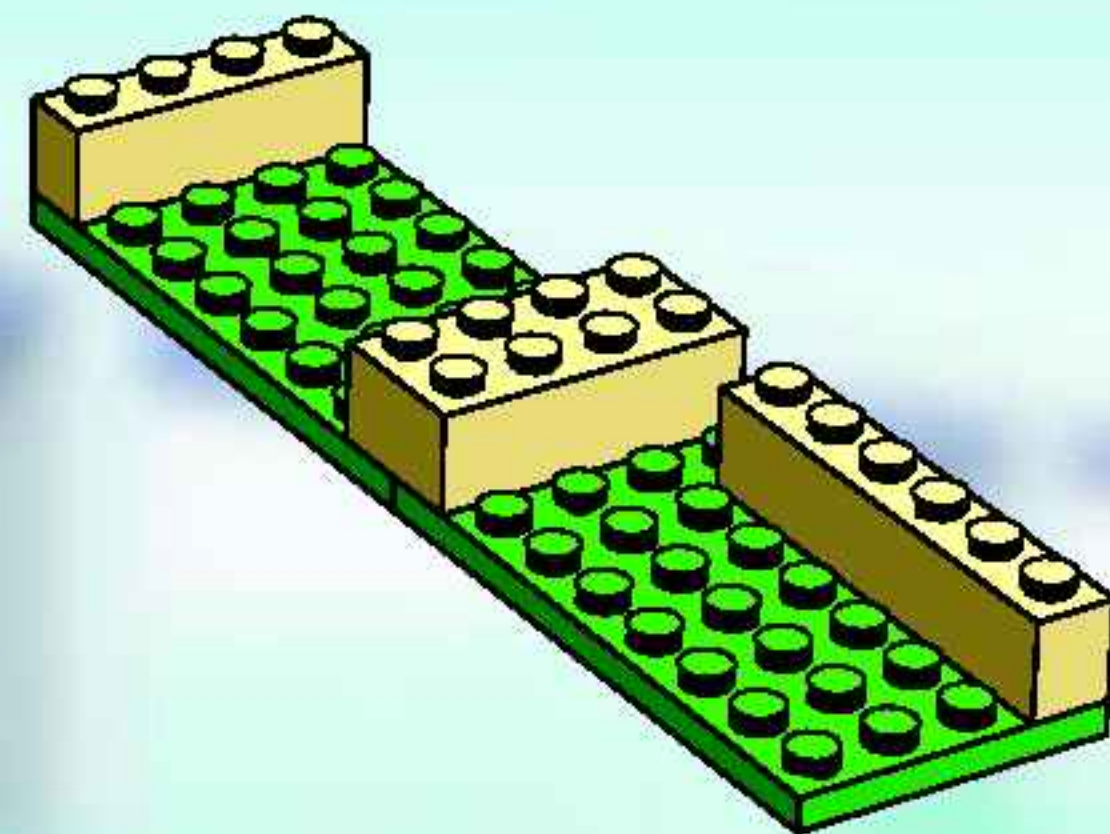



3

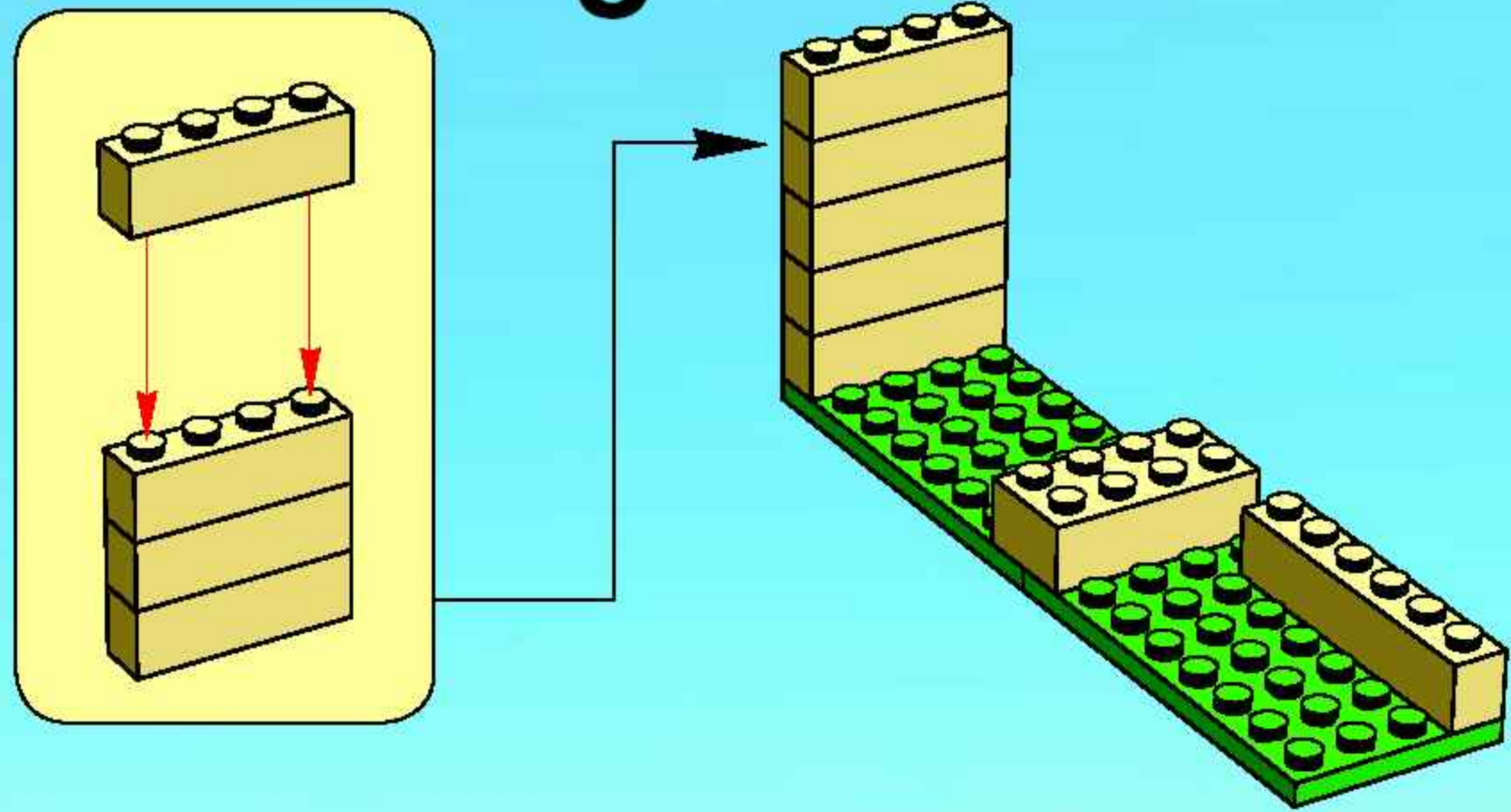

5

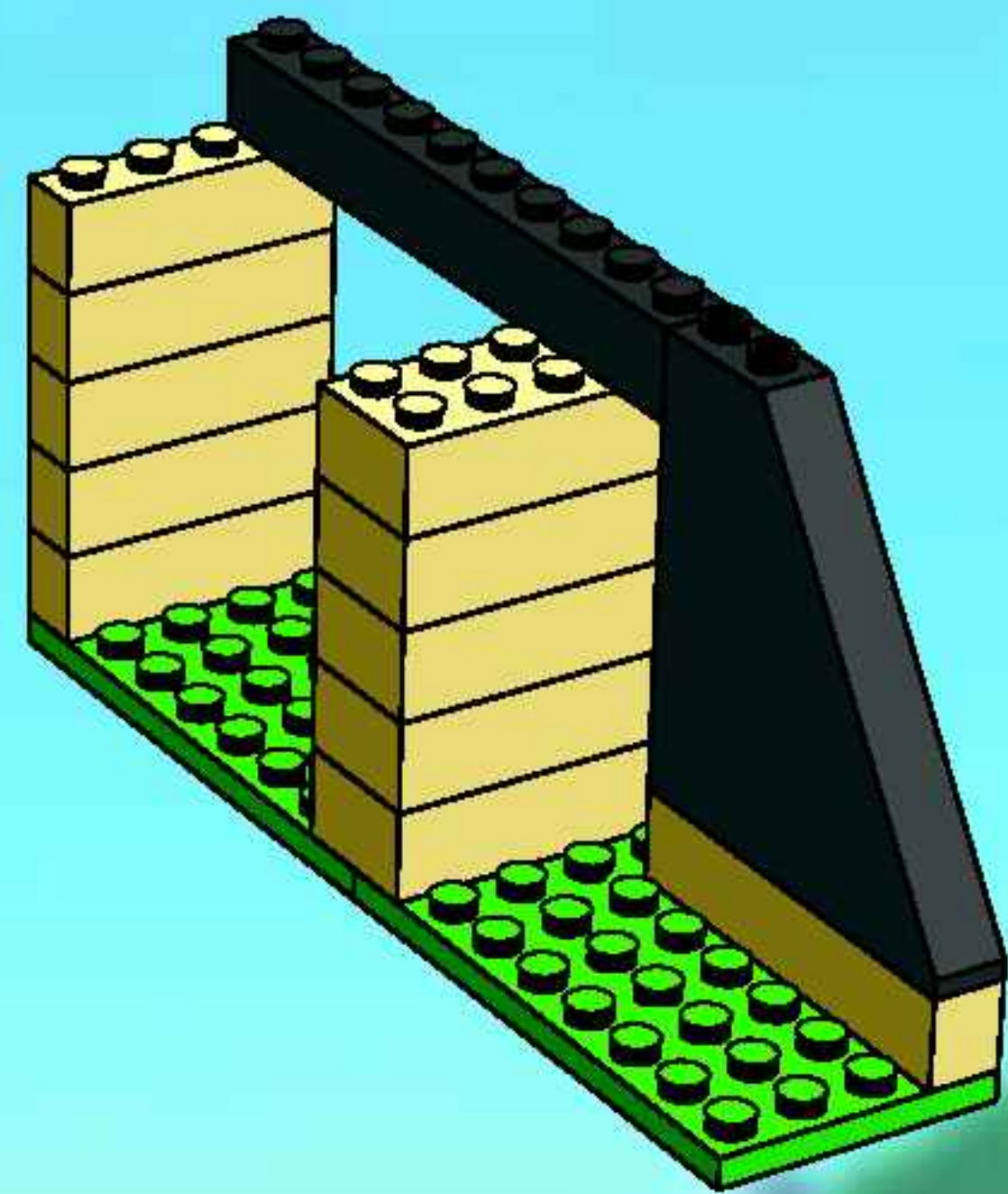

4

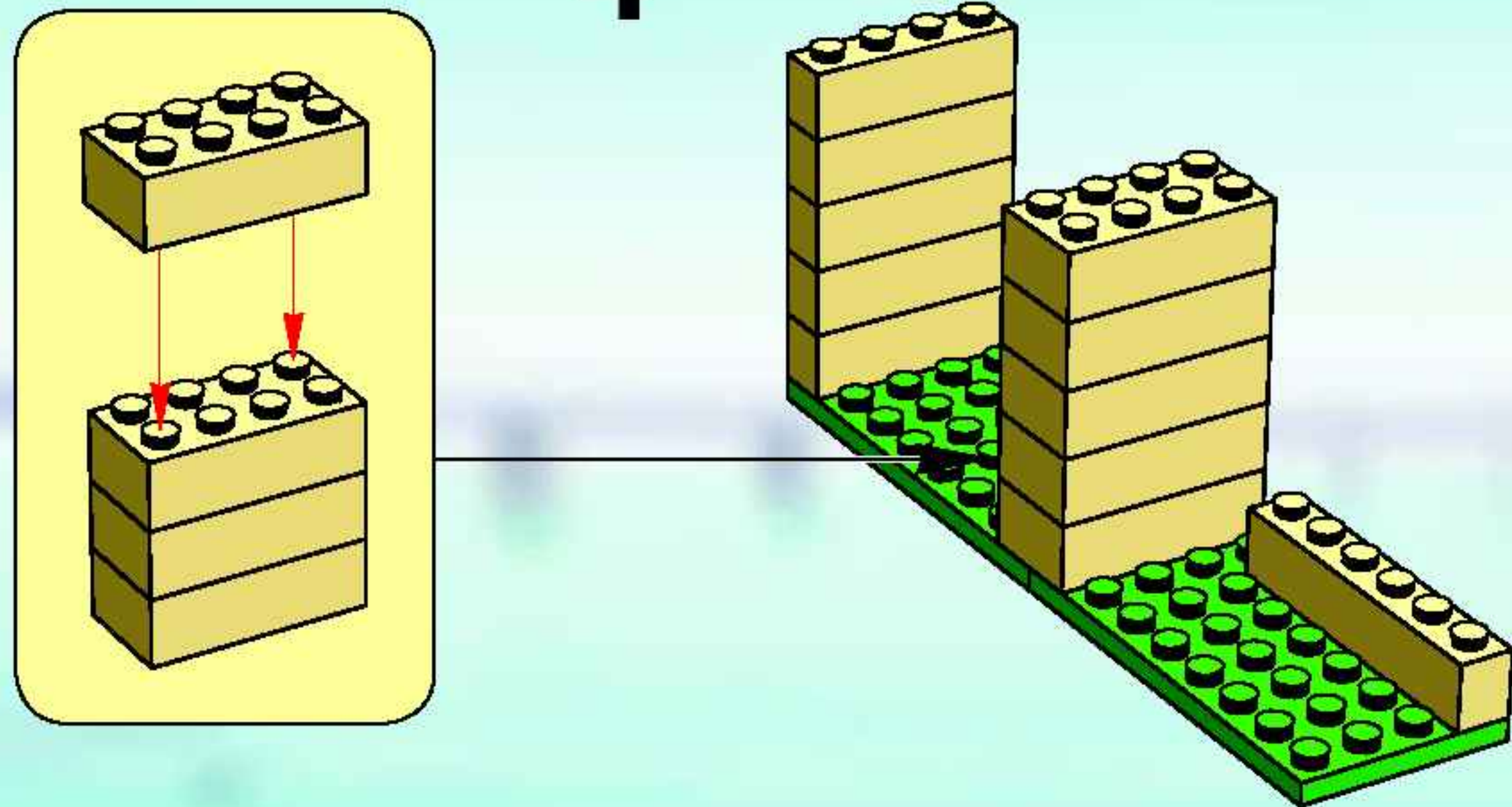

6

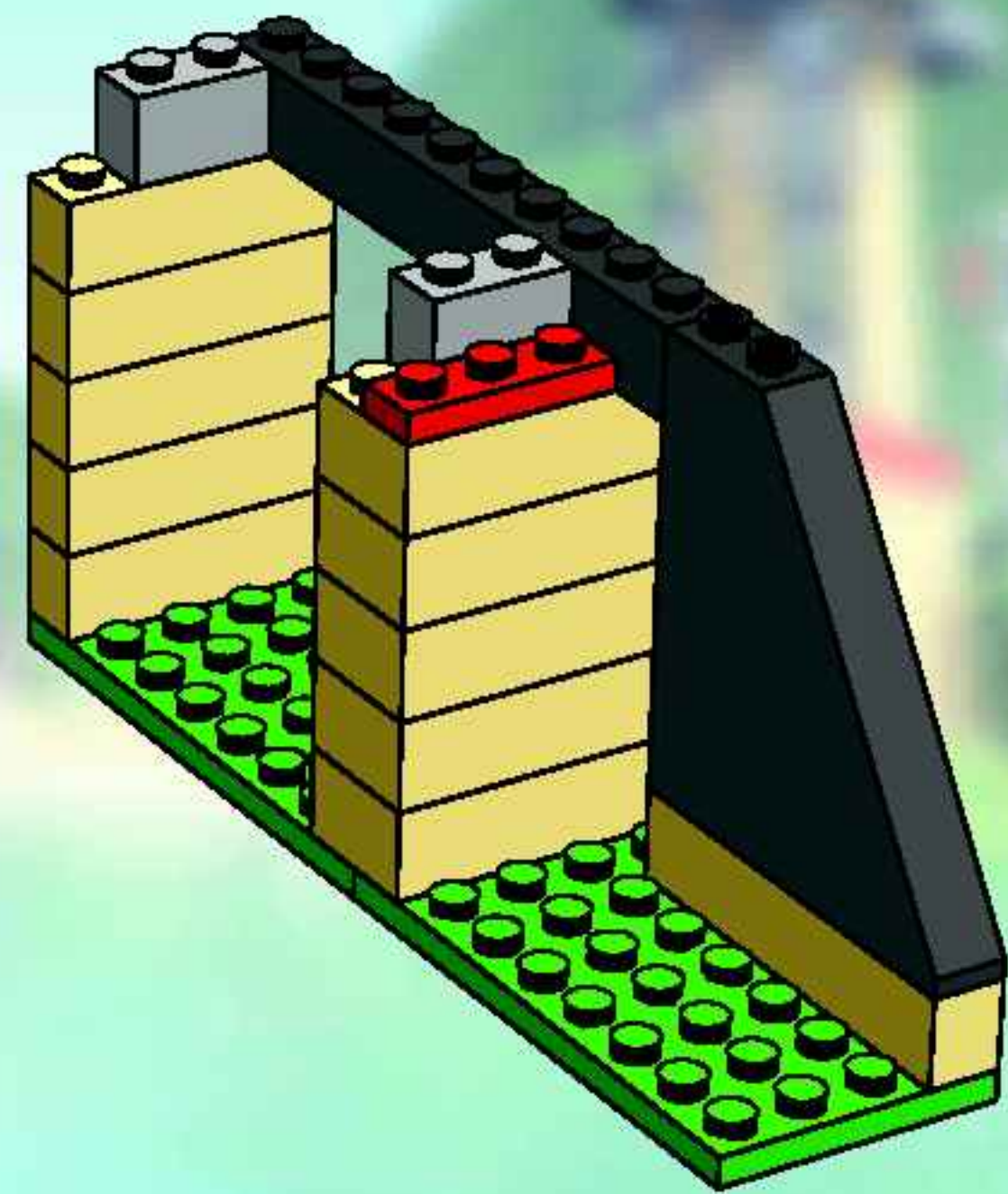



7

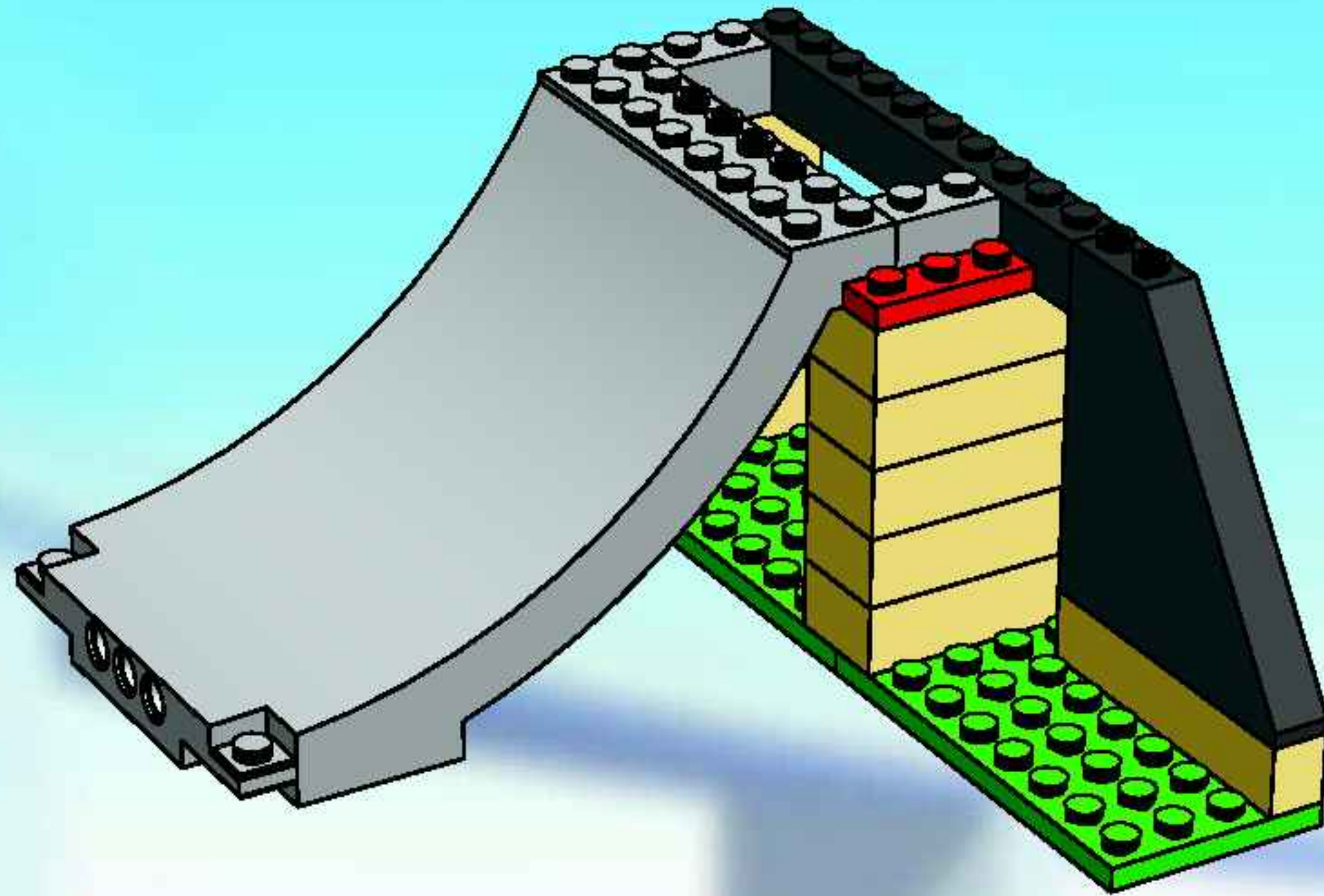



1

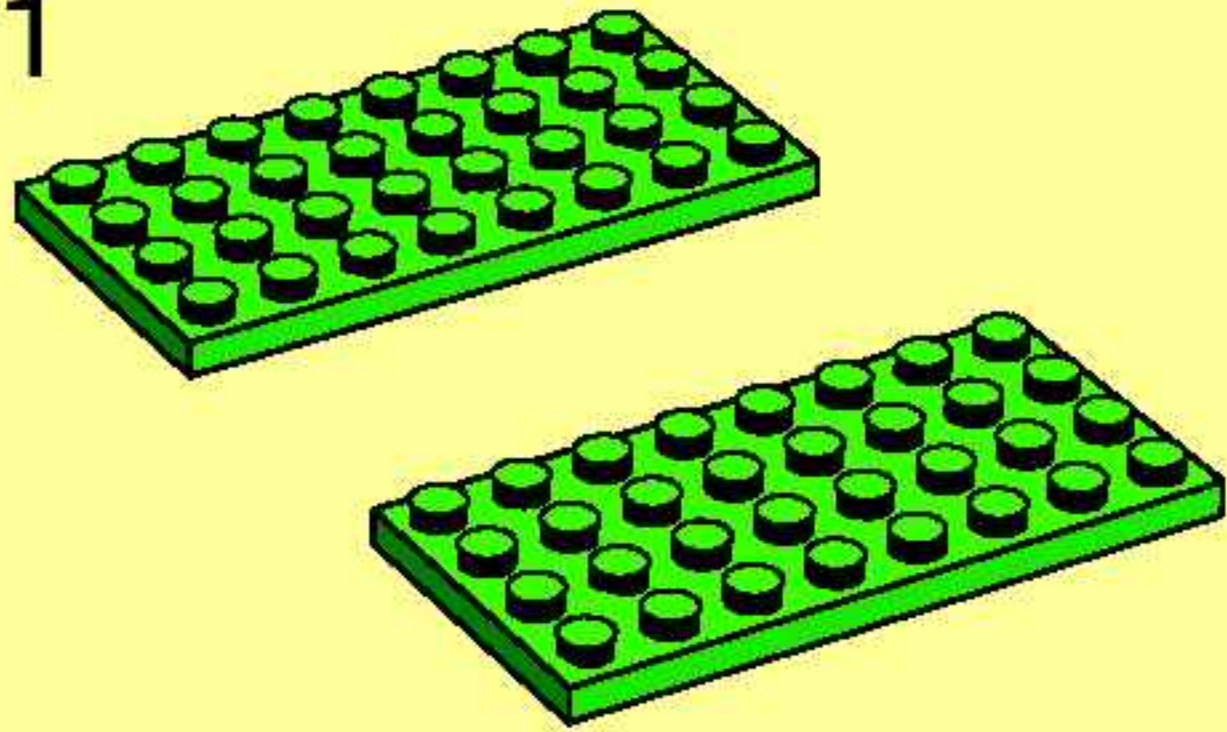

2

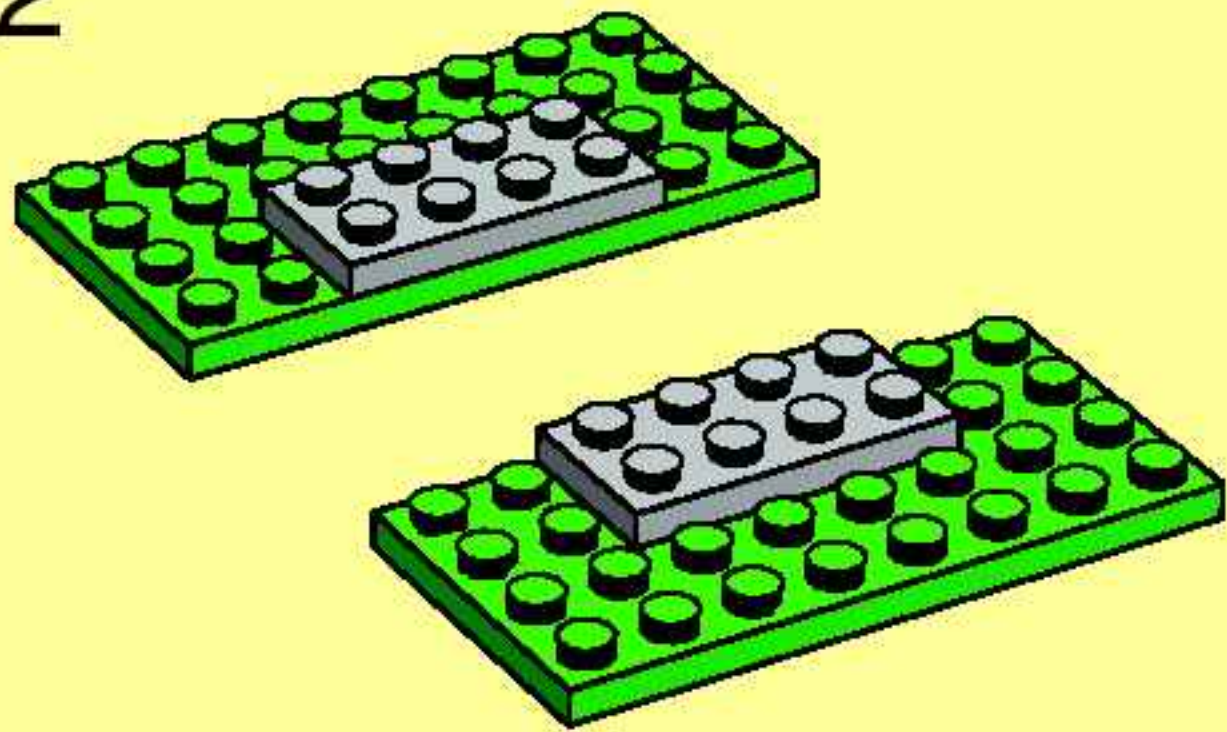

3

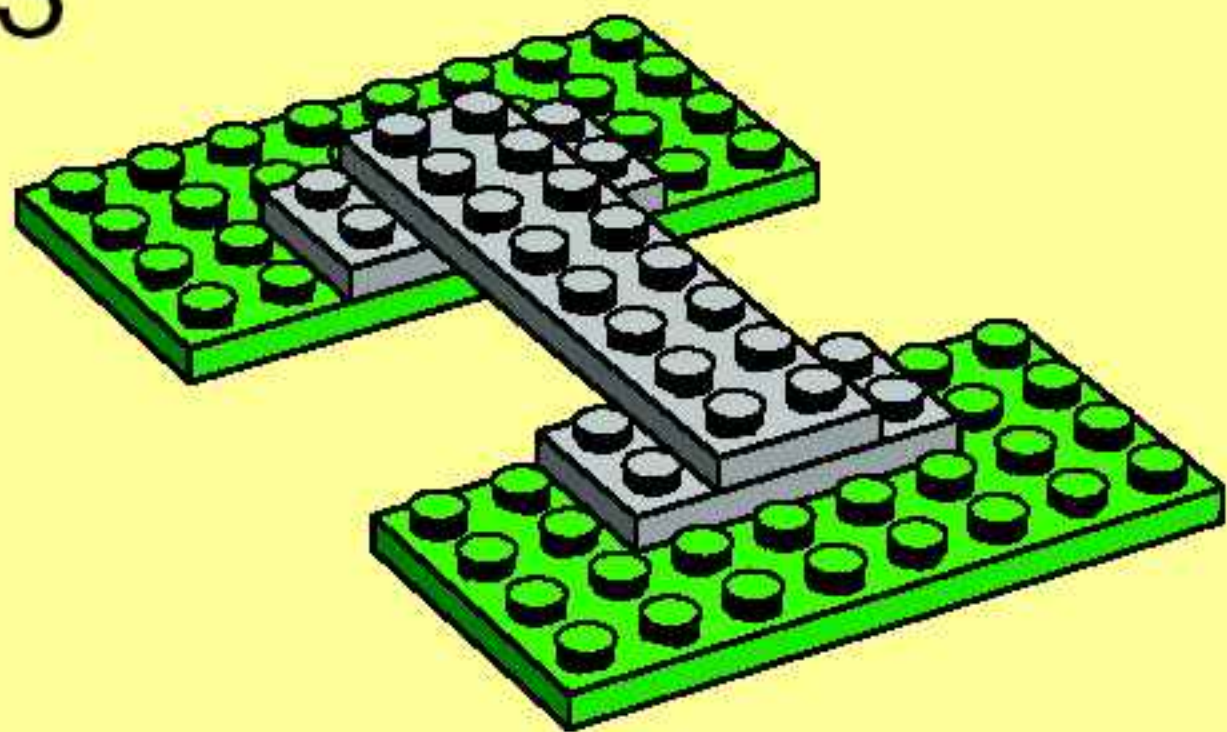

8

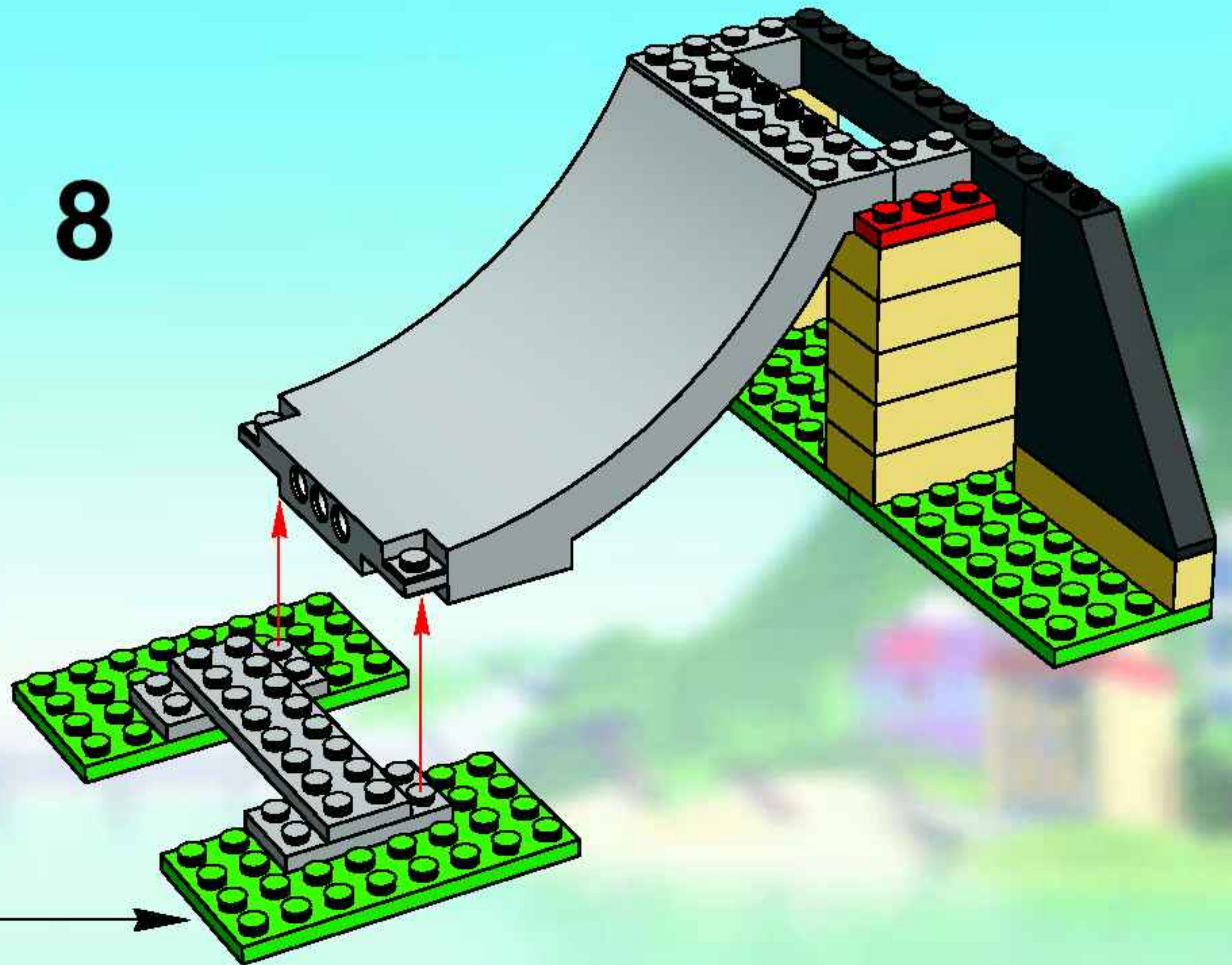



9

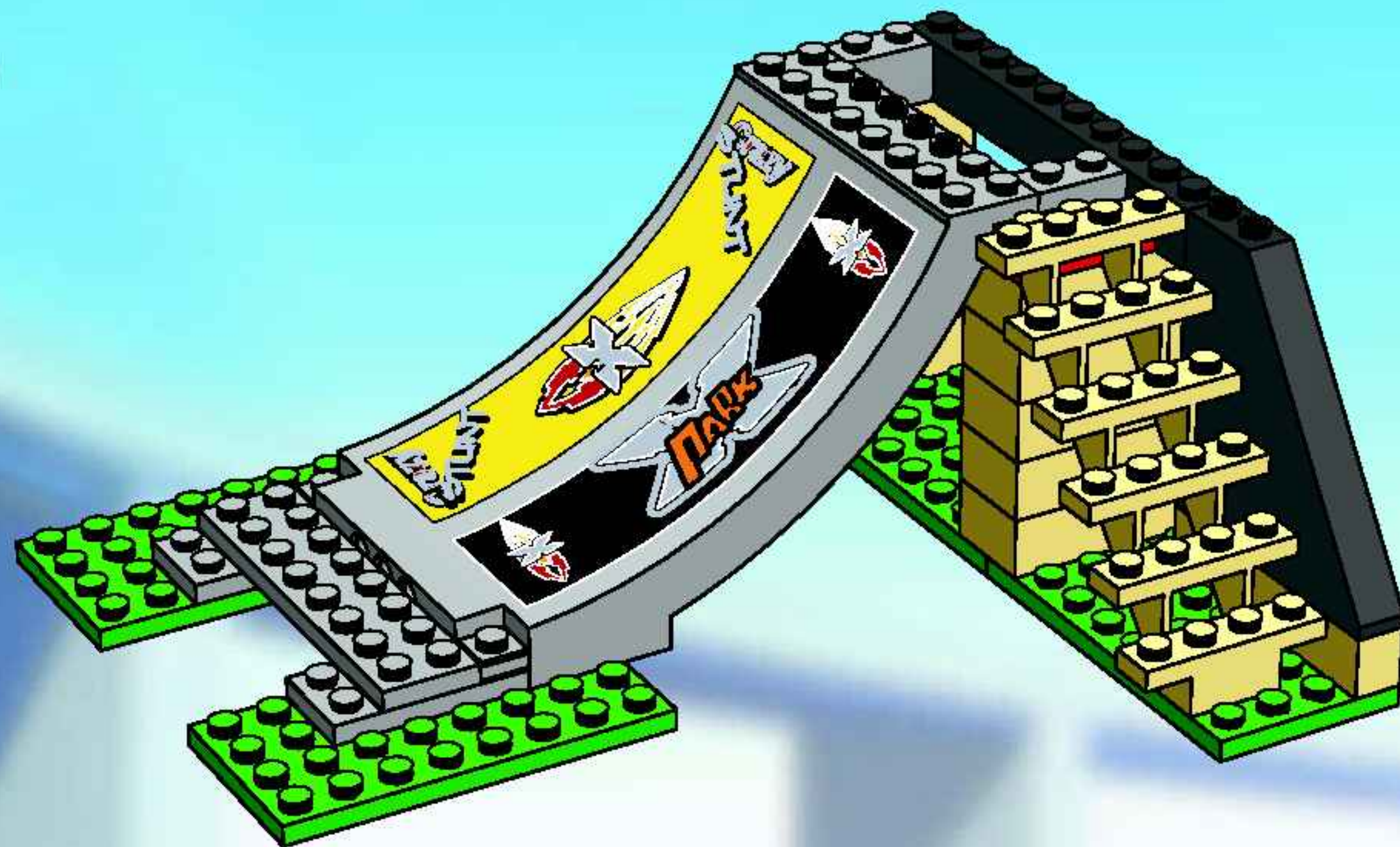



10

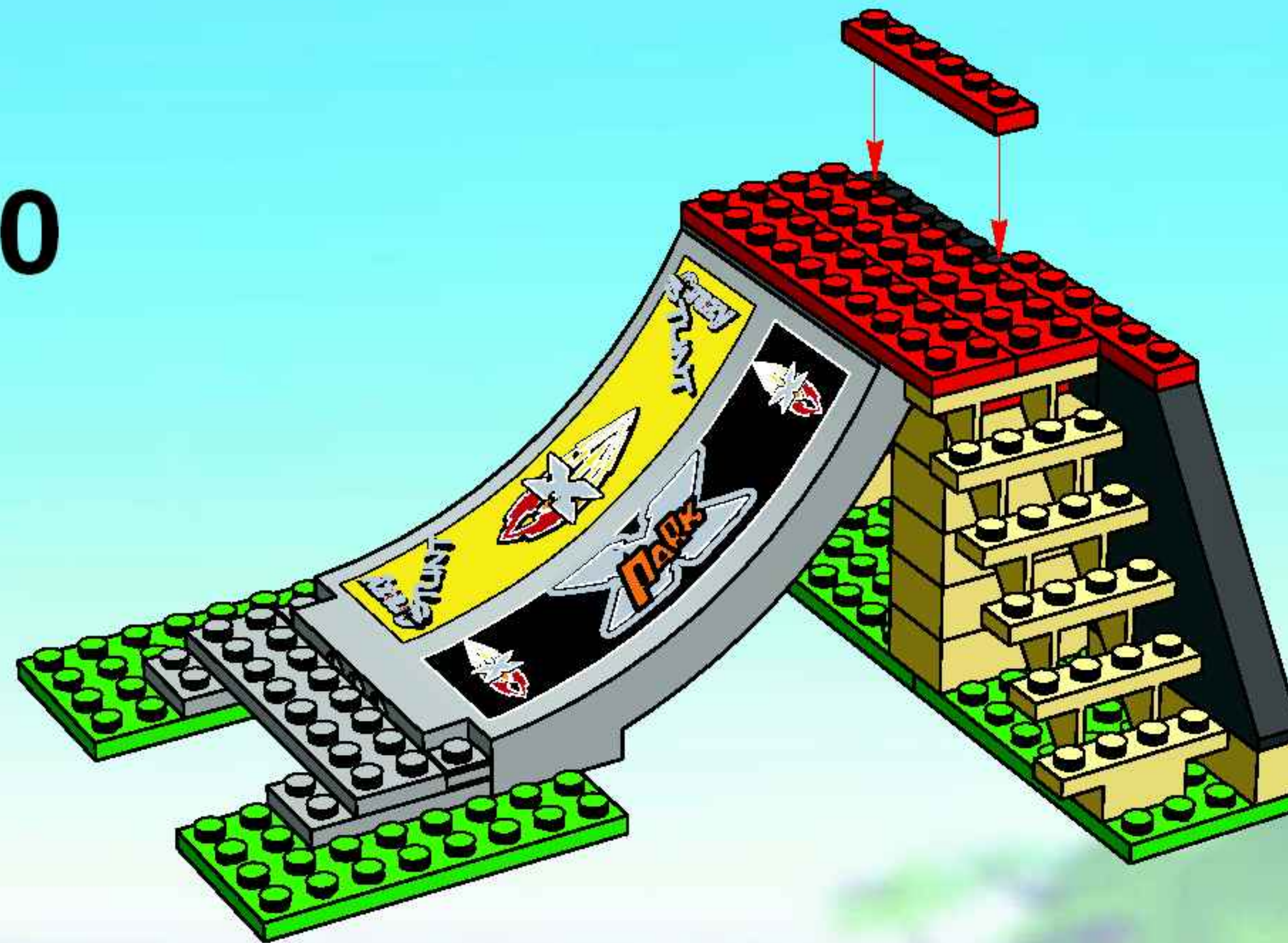



1

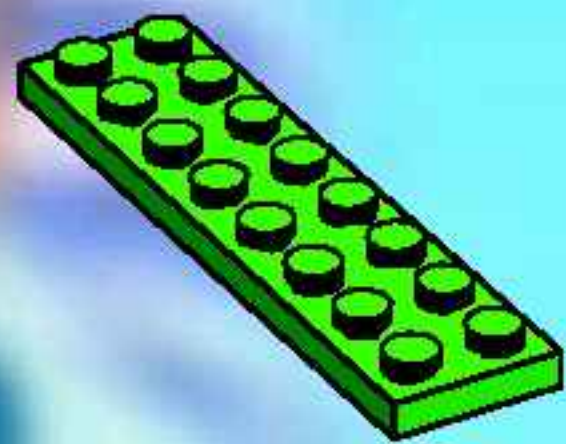

2

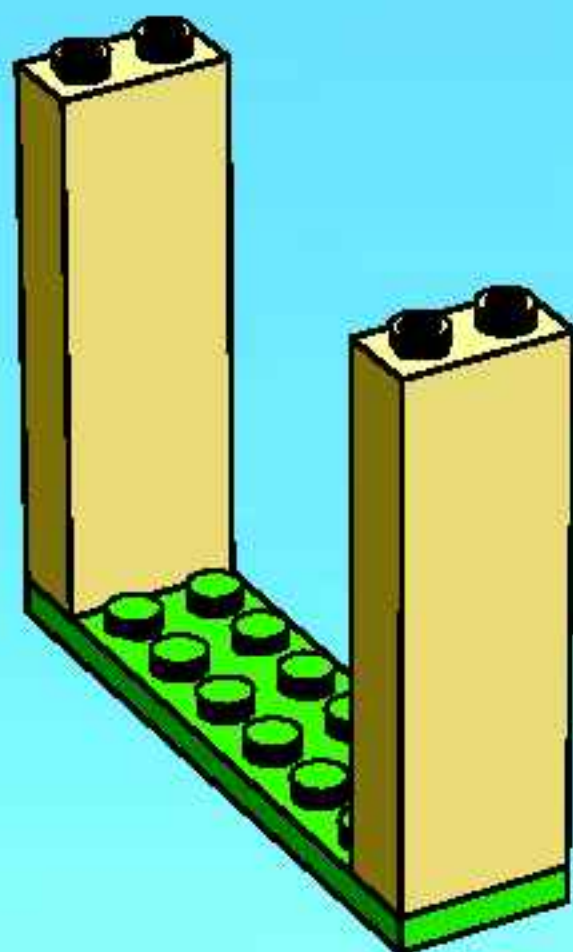

3

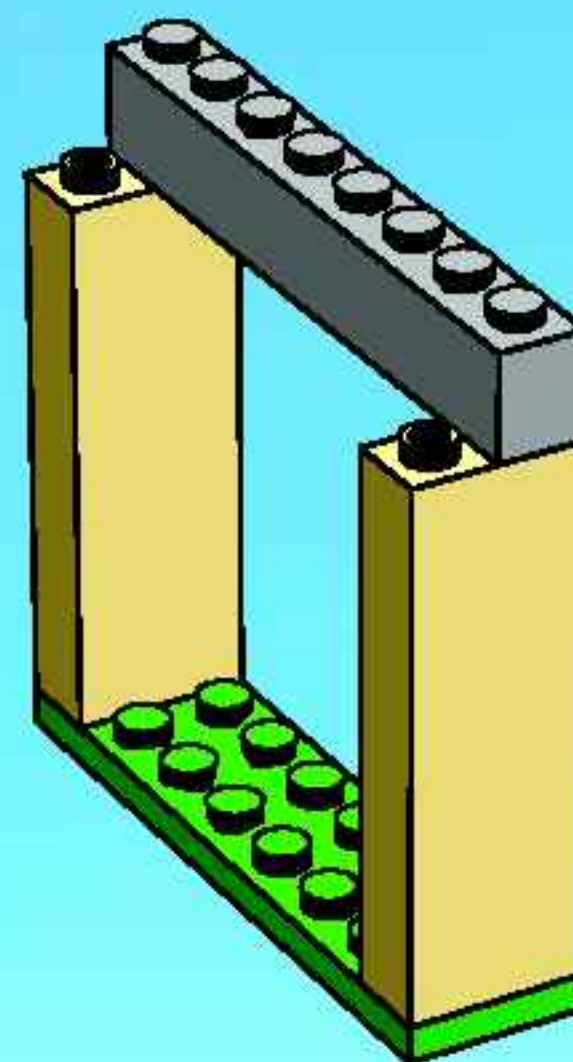

4

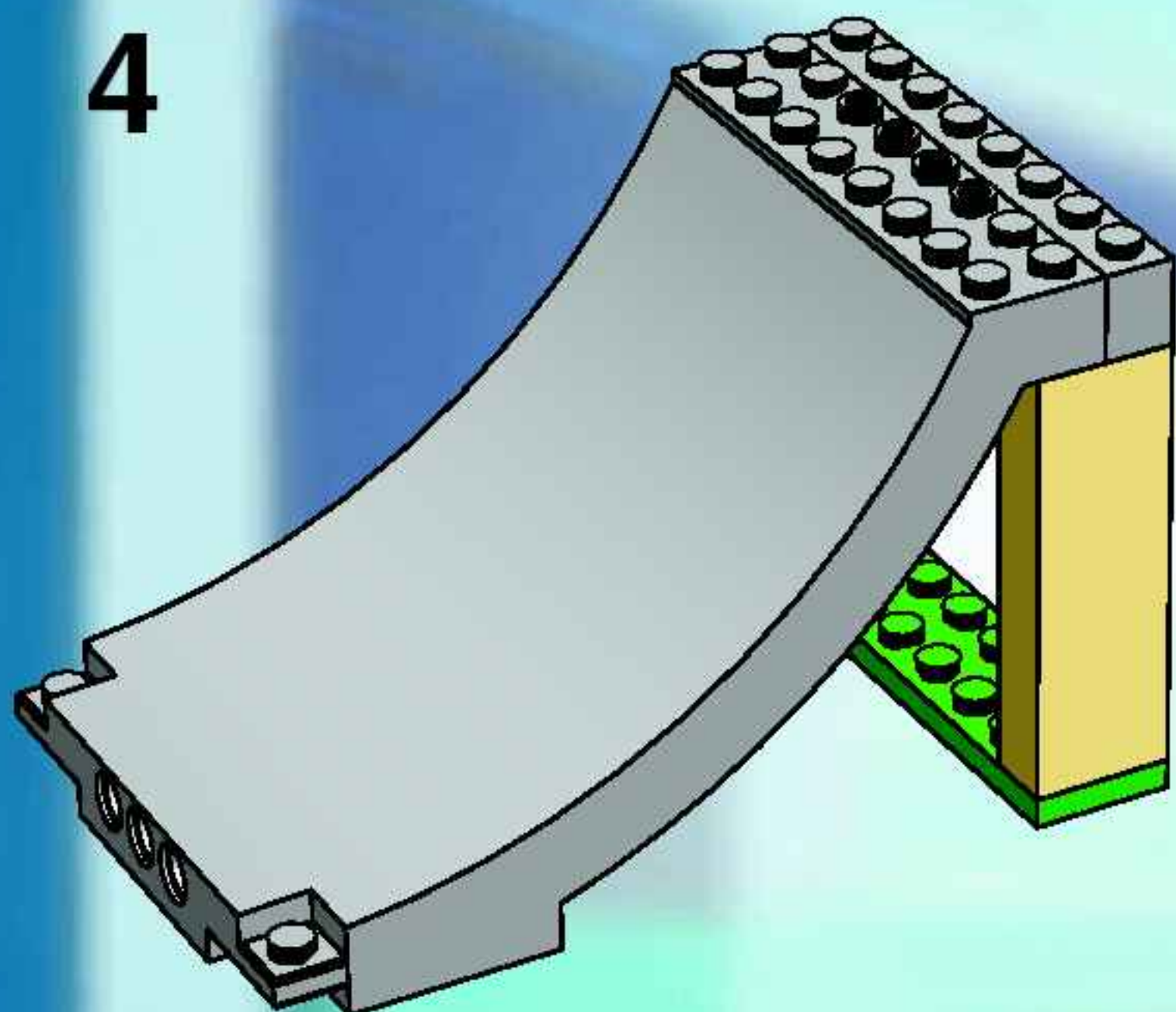

5

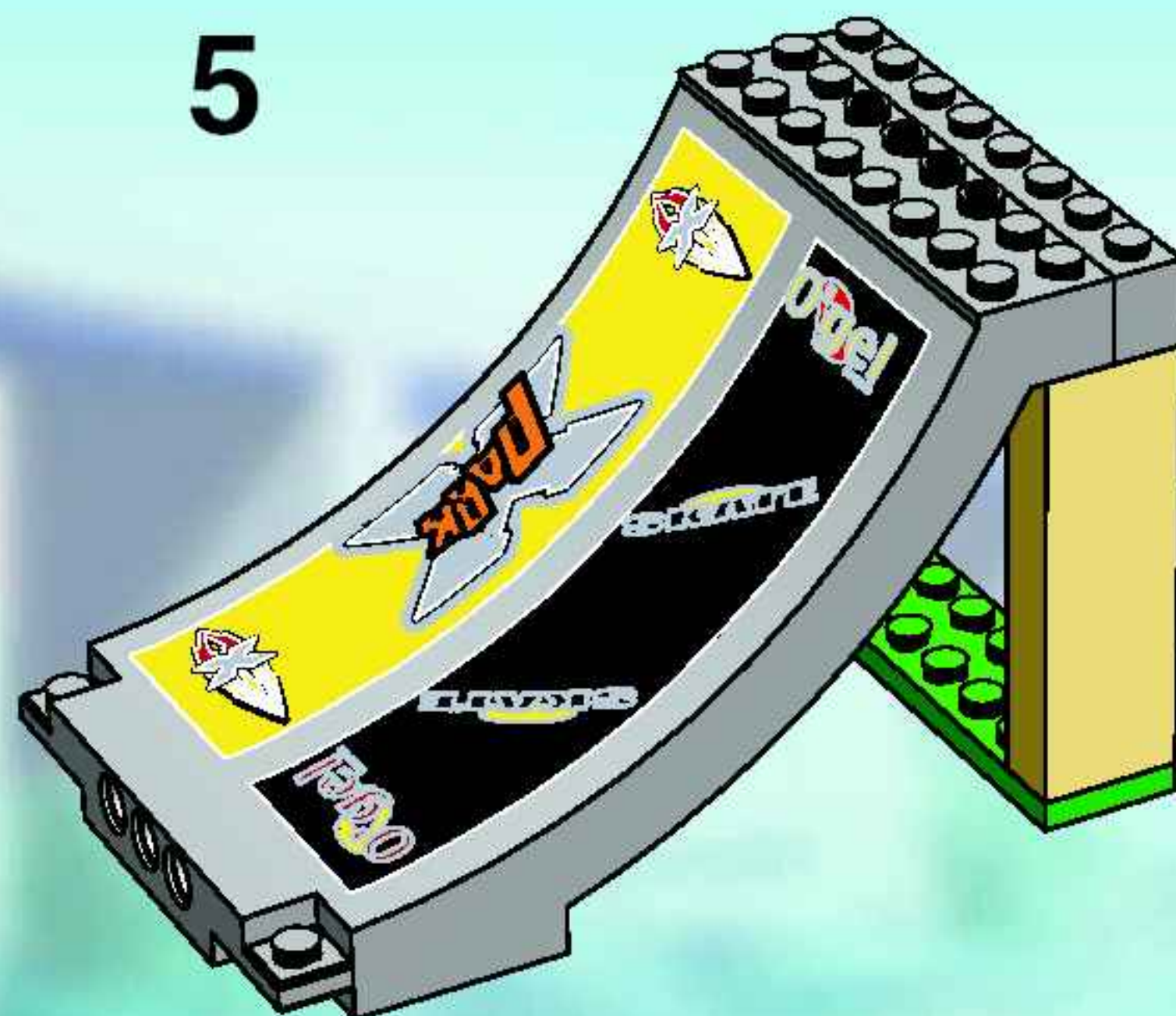



11

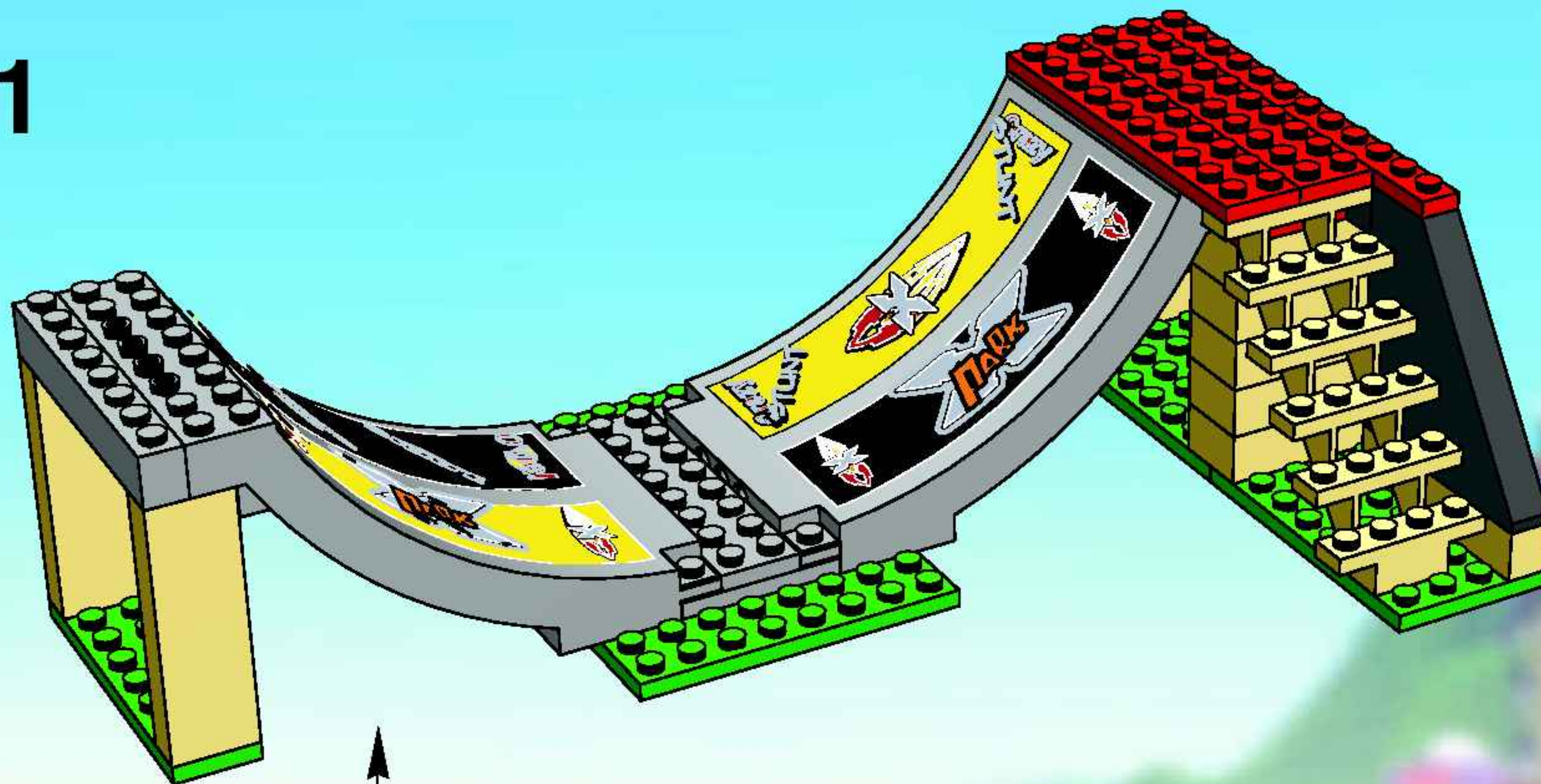



12

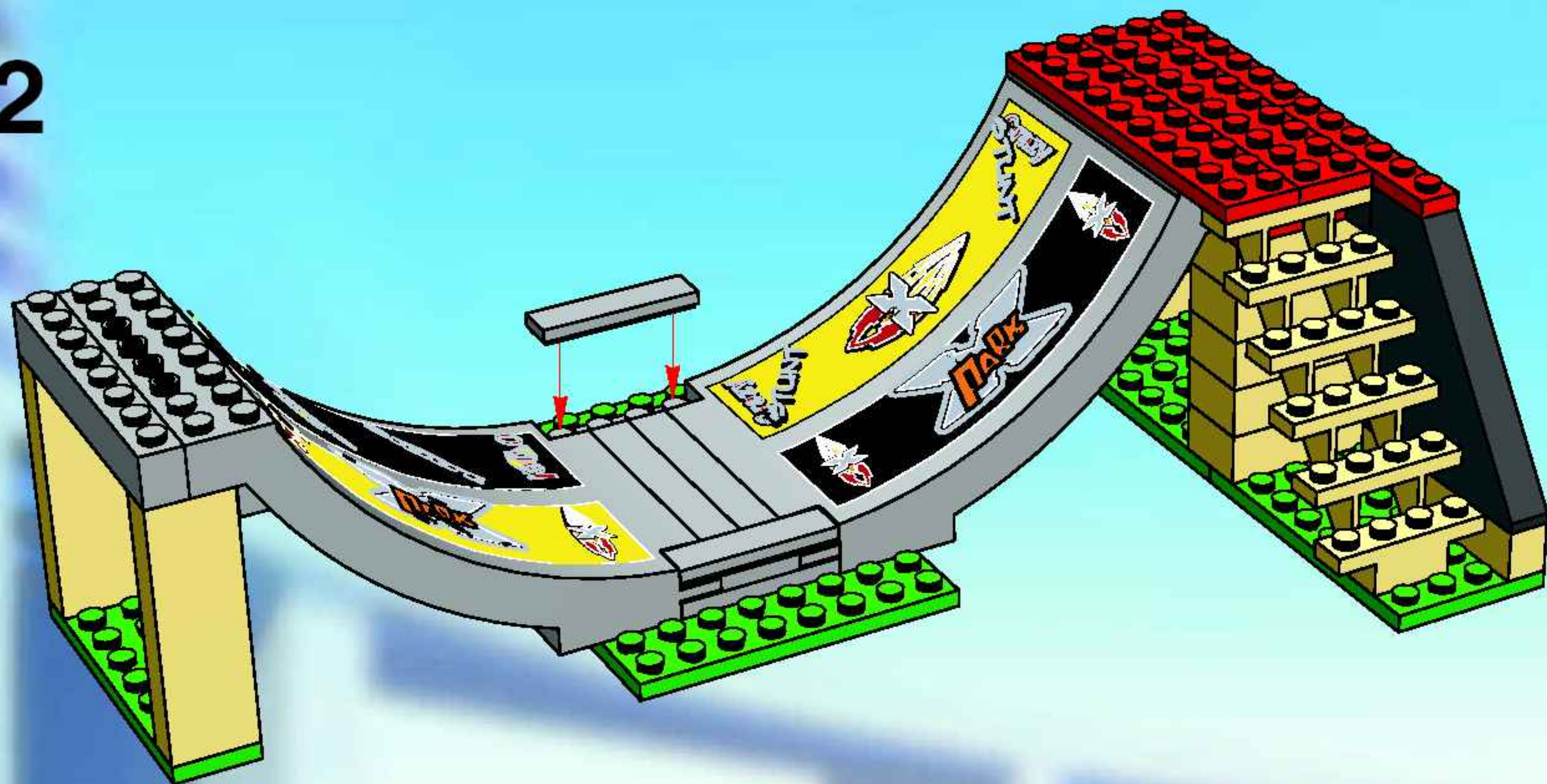



13

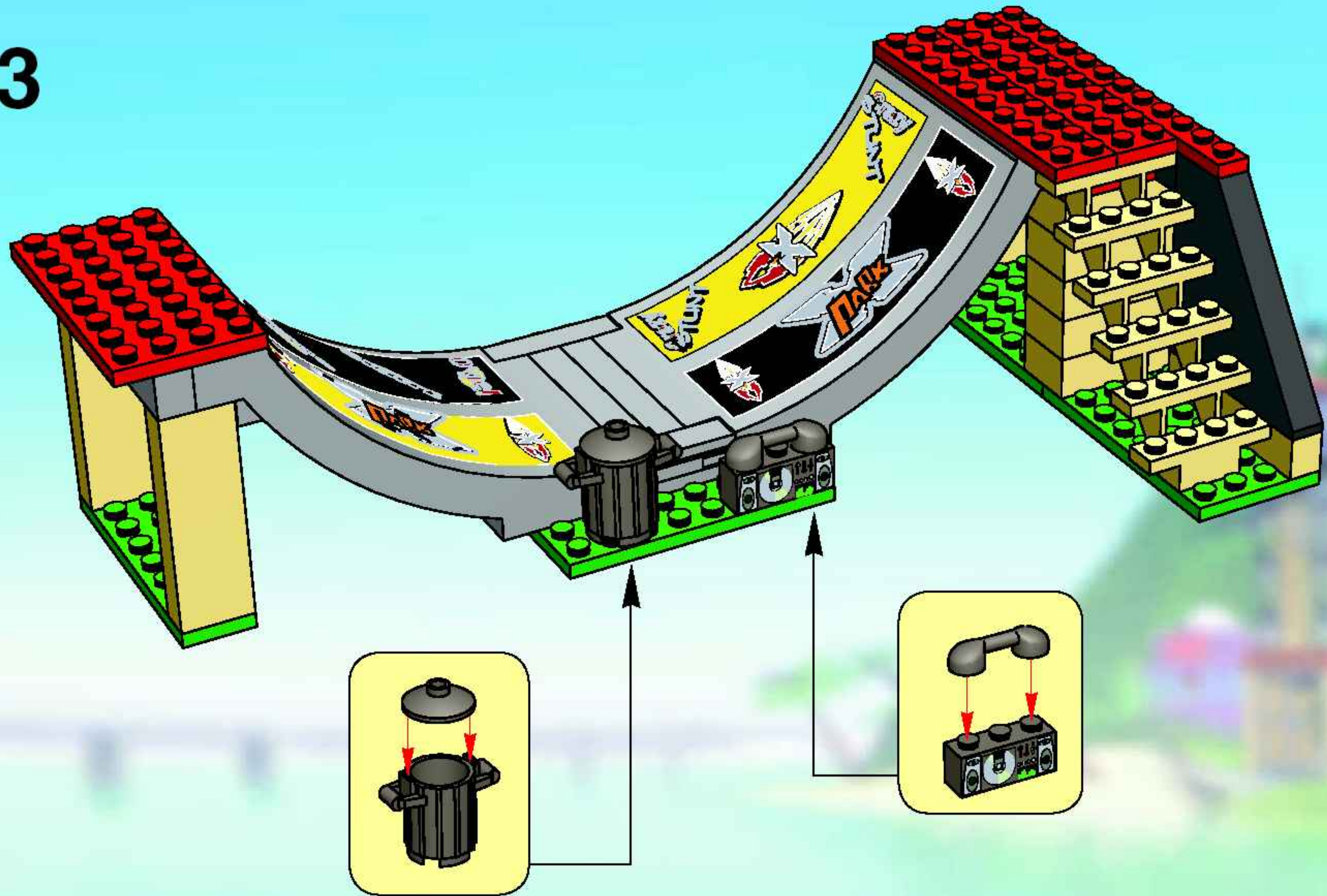



14

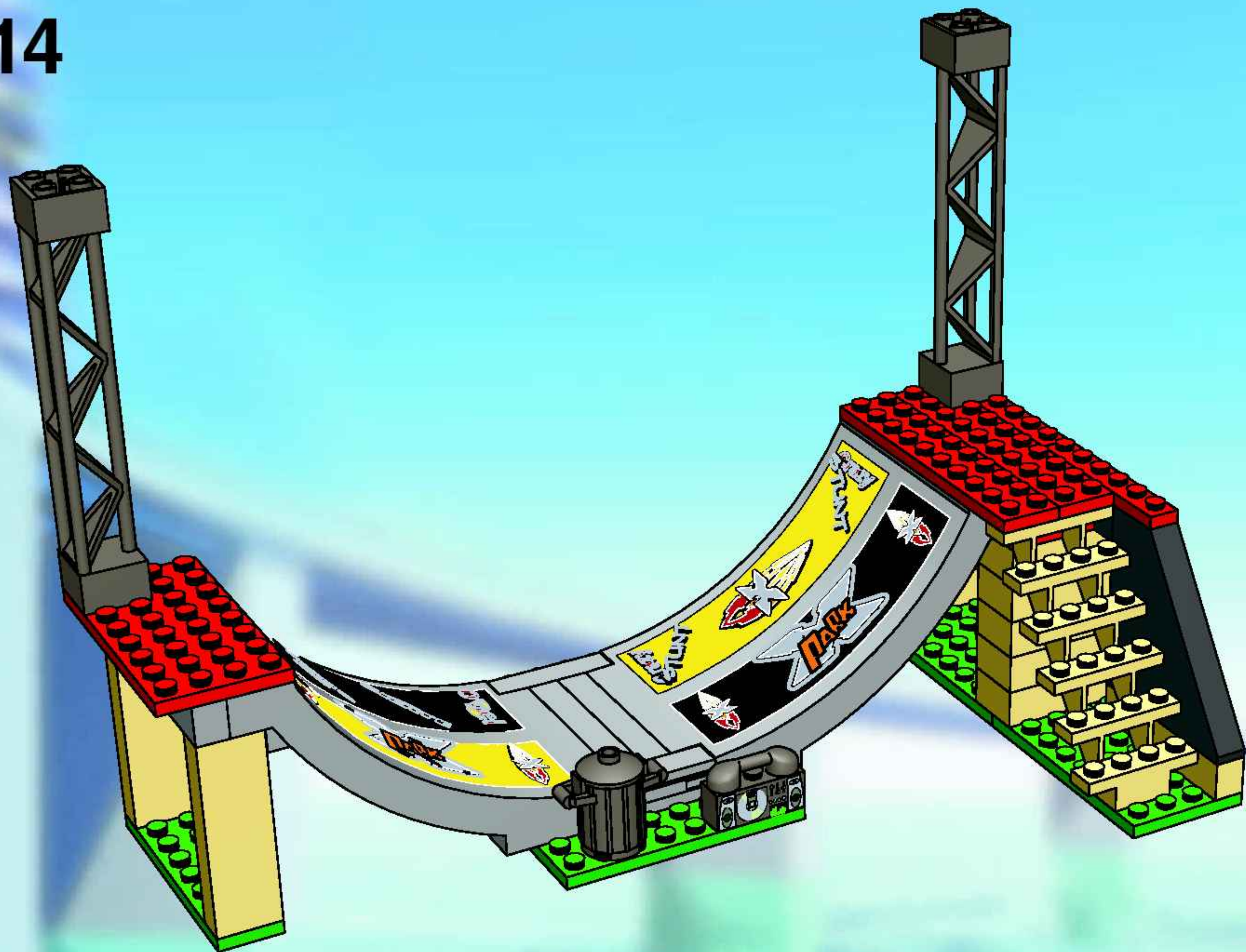



15

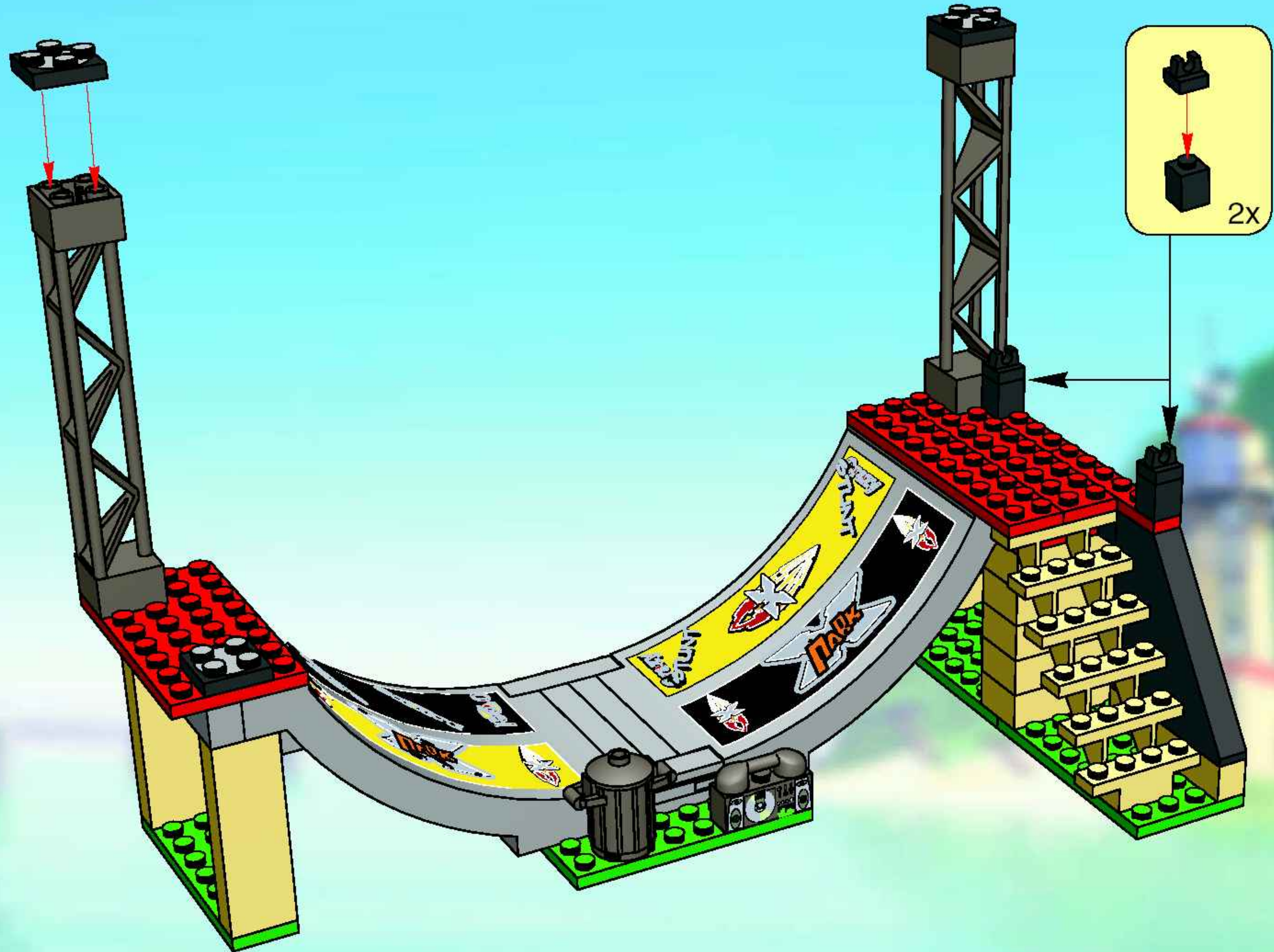



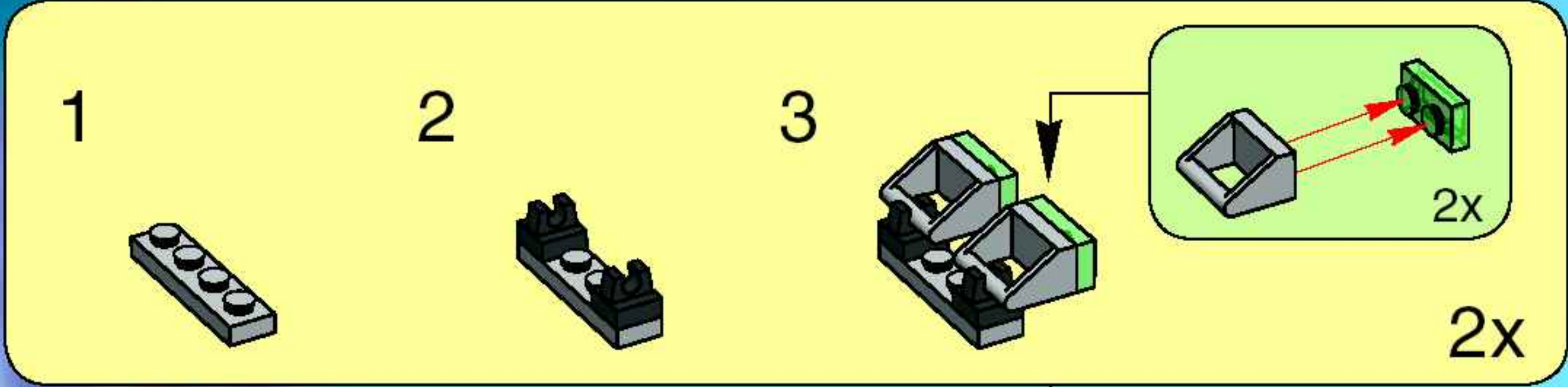

16

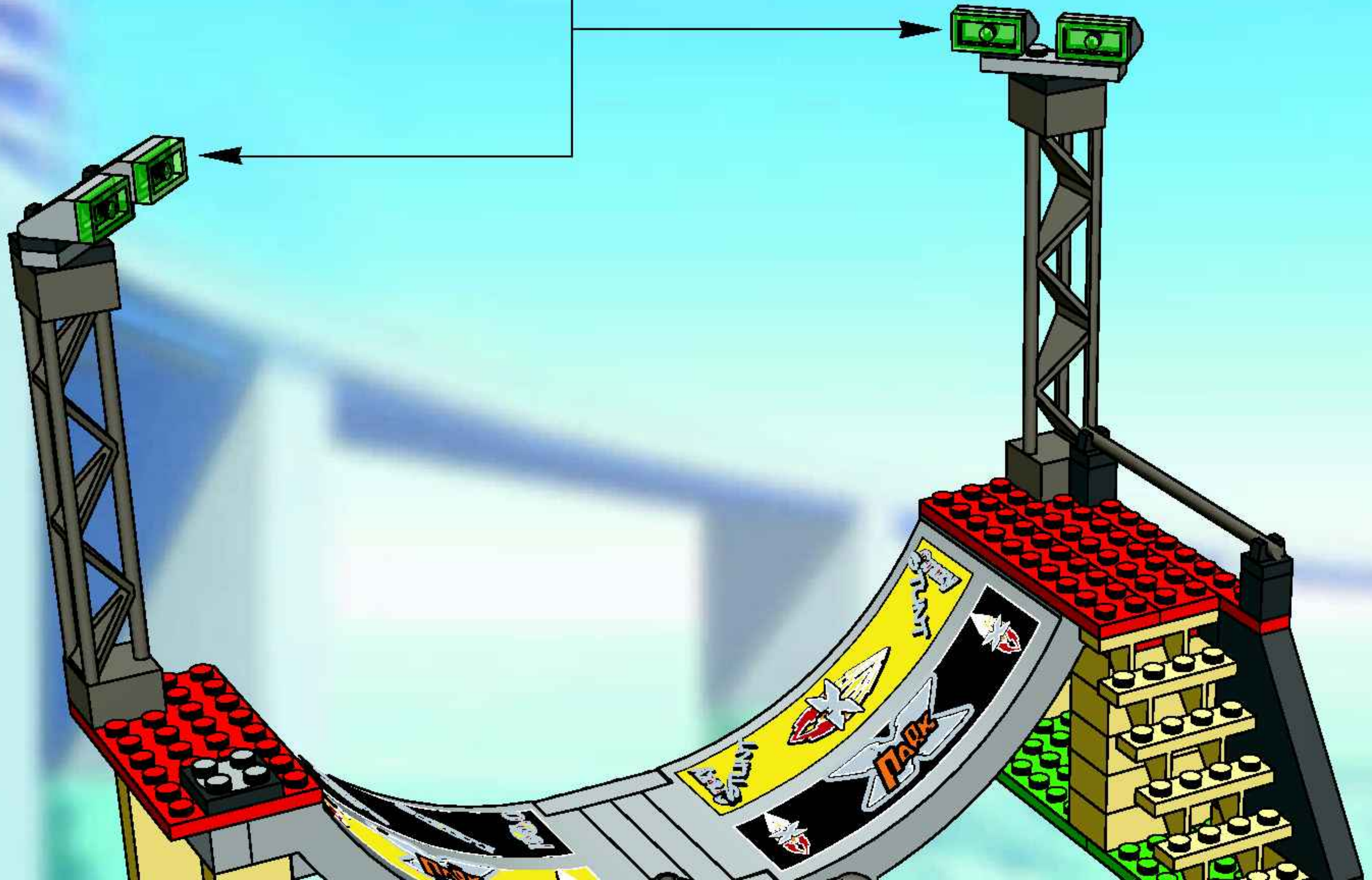



1

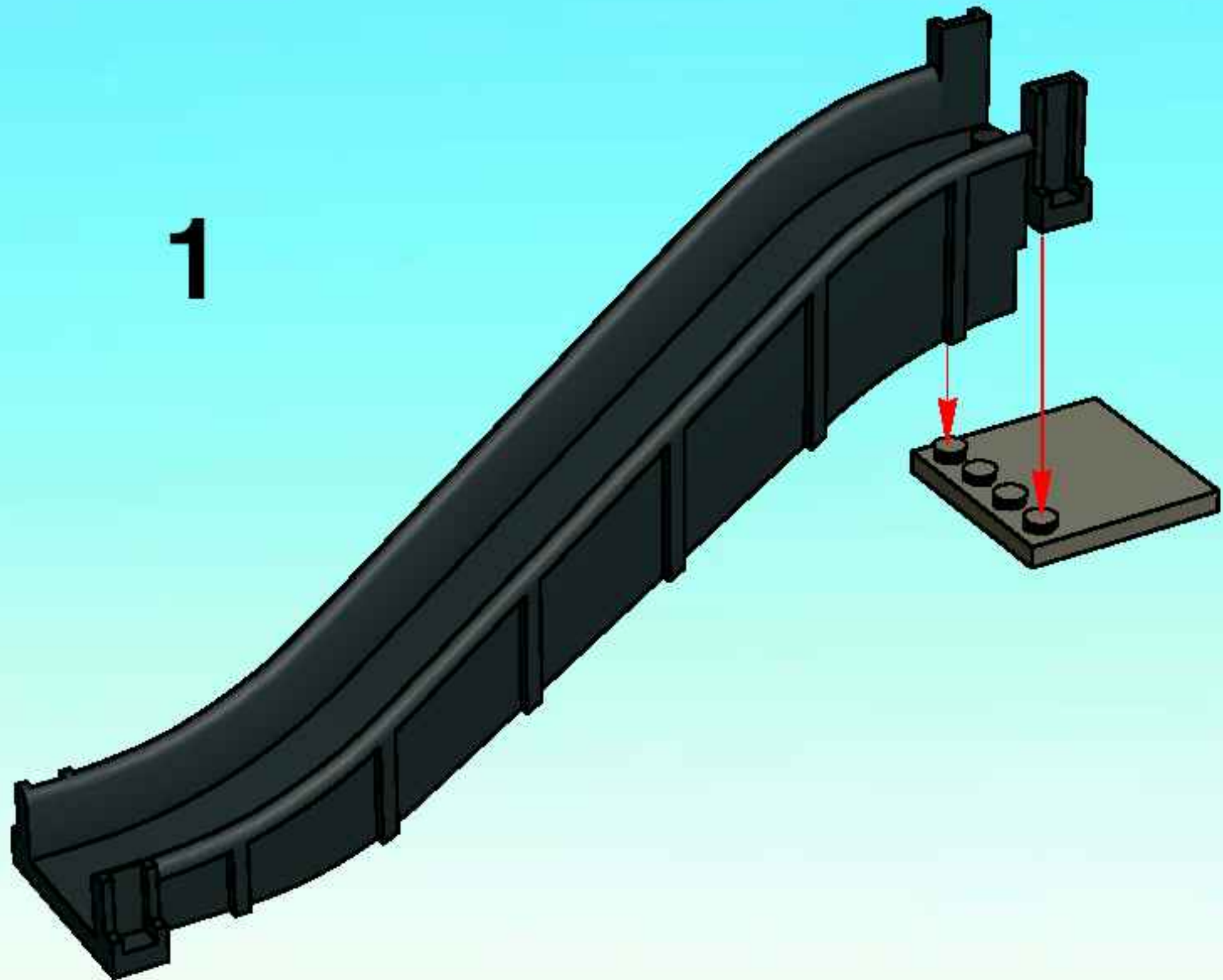

2





17

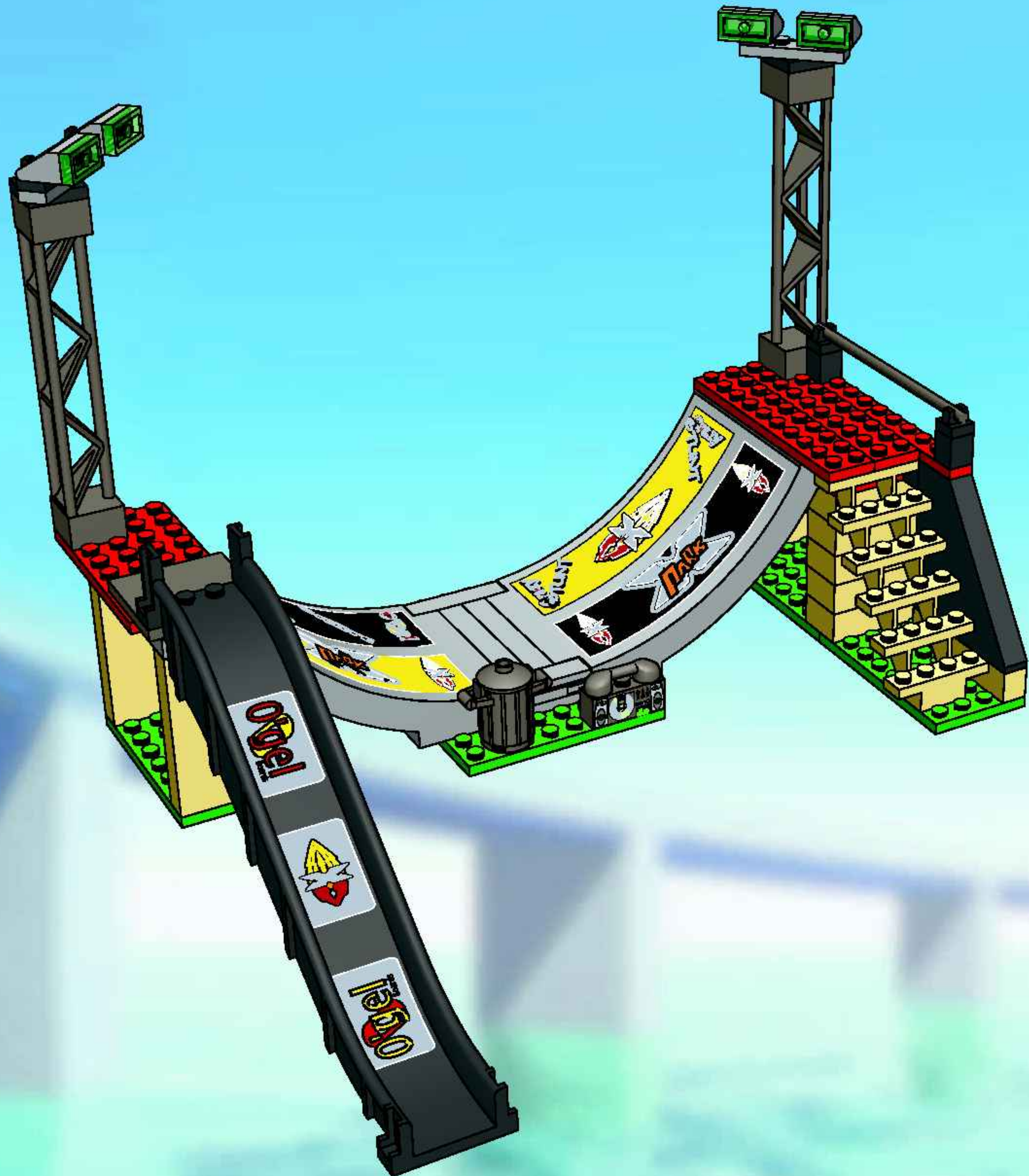







1

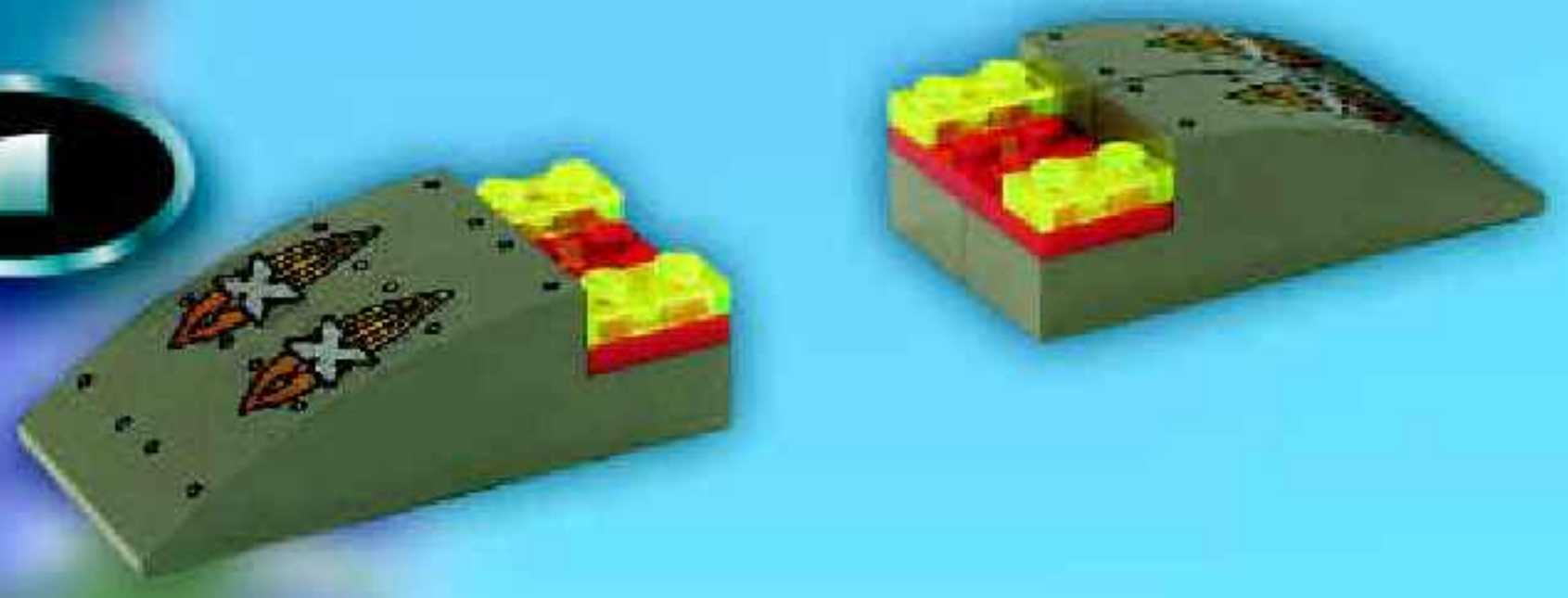

2

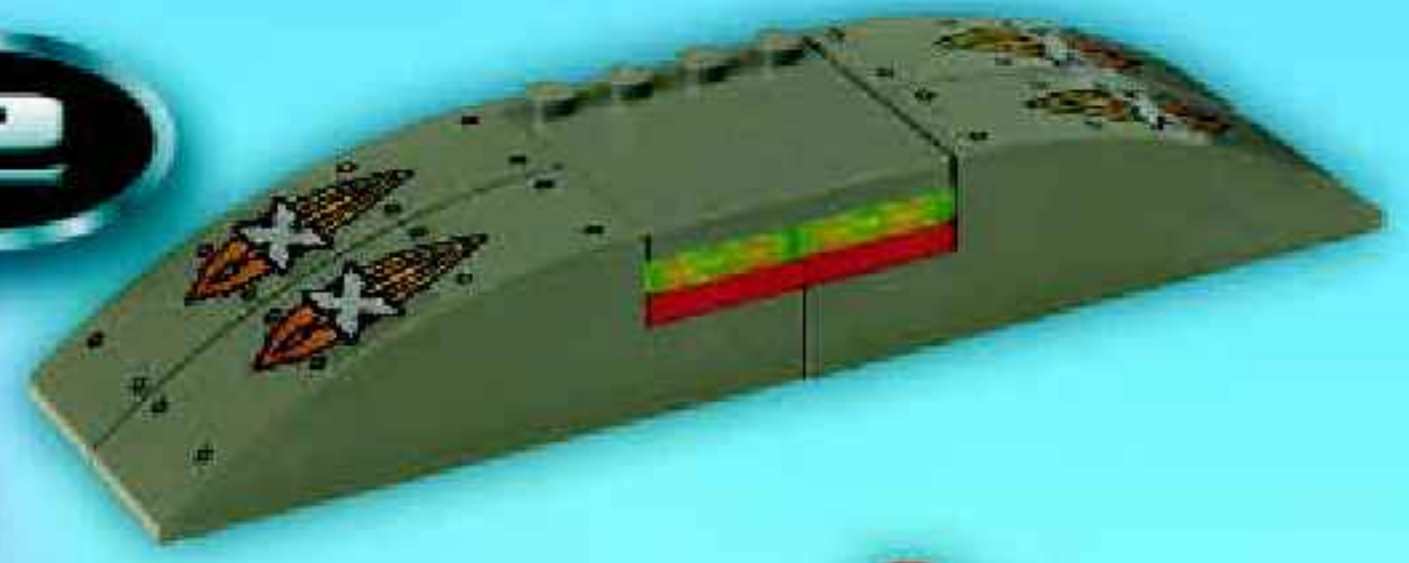

1



2







4



Dear LEGO user

Congratulations with your new LEGO product!

We would very much like to know your opinion of this LEGO product.

By answering a few questions you participate in a competition for valuable LEGO prizes.

Please go to this Internet address to answer the questions – it will take about 5 minutes:

[www.acnielsen.aim.dk/lego](http://www.acnielsen.aim.dk/lego)

If you are younger than 15 years, please ask one of your parents to answer the questions together with you.

This survey expires on 15 February, 2003.

Below you find some of the prizes you can win:

LEGO Company

Lieber LEGO Verbraucher

Herzlichen Glückwunsch zu Deinem neuen LEGO Produkt!

Wir möchten gerne Deine Meinung über dieses LEGO Produkt wissen.

Wenn Du einige Fragen beantwortest, kannst Du an einem Wettbewerb mit wertvollen LEGO Preisen teilnehmen.

Bitte auf dieser Internet Adresse die Fragen beantworten – es dauert nur etwa 5 Minuten.

[www.acnielsen.aim.dk/lego](http://www.acnielsen.aim.dk/lego)

Falls Du jünger als 15 Jahre bist, bitte Deine Eltern fragen, ob sie Dir dabei helfen.

Ablauf des Angebotes: 15. Februar 2003.

Hier siehst Du einige Produkte die Du gewinnen kannst.

LEGO Company

Cher consommateur LEGO

Félicitations pour l'achat de votre nouveau produit LEGO!

Nous aimerions bien connaître votre avis sur ce produit LEGO.

En répondant à quelques questions, vous participerez à un concours pour des prix en produits LEGO.

Veillez aller à cet adresse internet et répondre aux questions - cela vous prendra environ 5 minutes :

[www.acnielsen.aim.dk/lego](http://www.acnielsen.aim.dk/lego)

Si vous avez moins de 15 ans, demandez s.v.p. à l'un de vos parents de répondre aux questions avec vous.

Cette étude expirera le 15 février 2003.

Au-dessous, vous pouvez voir certains des prix que vous pouvez gagner :

La compagnie LEGO

レゴユーザーのみなさんへ

レゴ新せい品を買ってくれてありがとう！

このレゴせい品に関するあなたの感想を聞かせてください。

質問に答えていただくと、すてきなレゴせい品がちゅうせんで当たります。

質問に答えるには、次のインターネットアドレスに入ってください。—5分ほどで終了します：

[www.acnielsen.aim.dk/lego](http://www.acnielsen.aim.dk/lego)

15才になっていない方は、ほごしゃの人と一緒に答えてください。

しめ切りは、2003年2月15日です。

ここにいくつかの賞品をしょうかいします：

レゴ社

# WIN LEGO PRIZES



[www.LEGO.com](http://www.LEGO.com)

© 2002 LEGO Group.