



# Friends



# 3183



**WARNING: CHOKING HAZARD.**  
Toy contains small parts and a small ball.  
Not for children under 3 years.

1

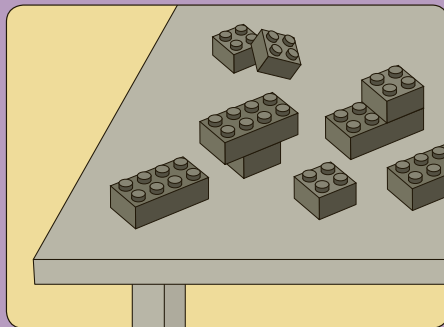
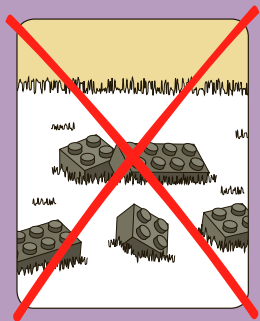

2

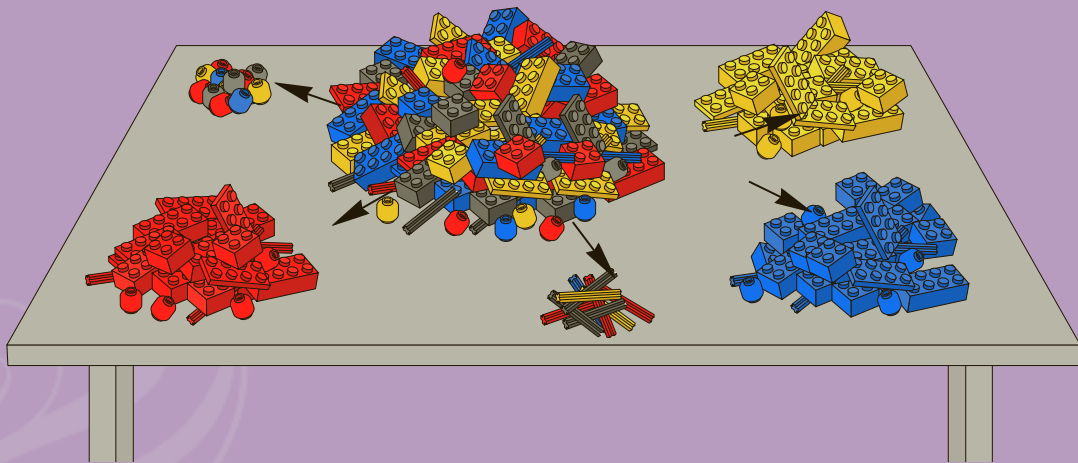



**AVERTISSEMENT : RISQUE D'ÉTOUFFEMENT.**  
Le jouet contient des petites pièces ainsi qu'une petite boule.  
Il ne convient pas aux enfants de moins de 3 ans.



**ADVERTENCIA: PELIGRO DE ASFIXIA.**  
Juguete que contiene partes pequeñas y una pelota pequeña.  
No recomendado para niños menores de 3 años.

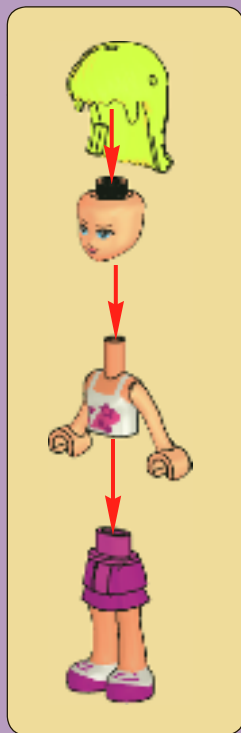

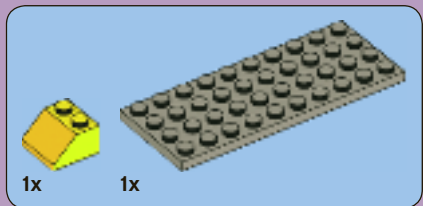

1

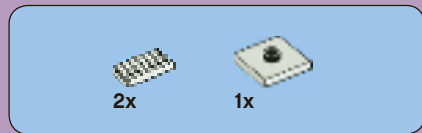
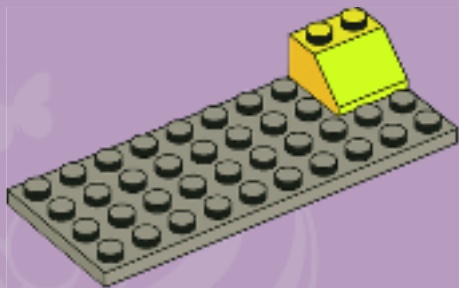

2

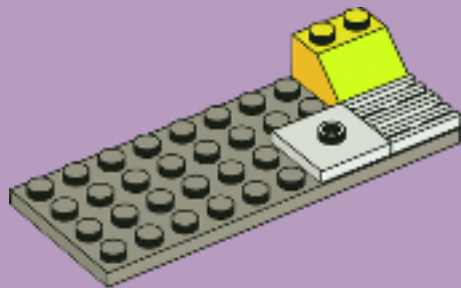



3x

3

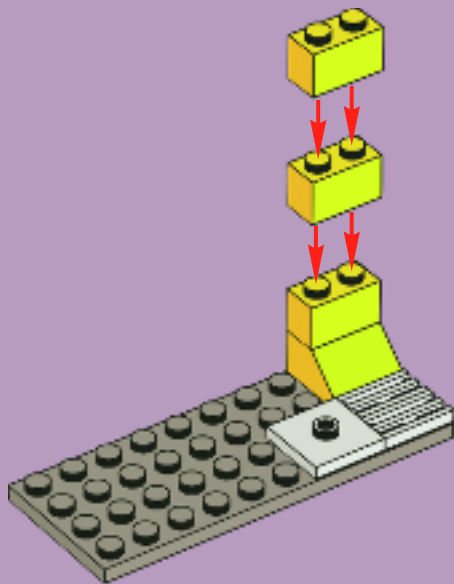

2x



1x

4

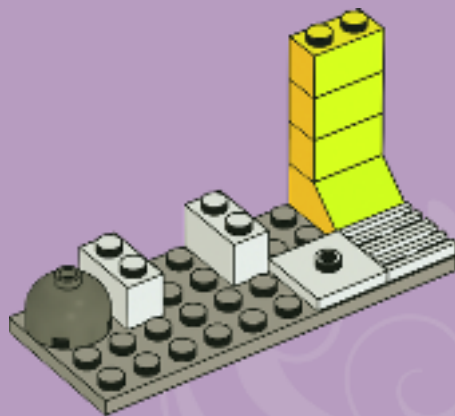

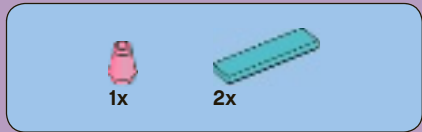

5

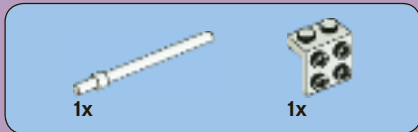
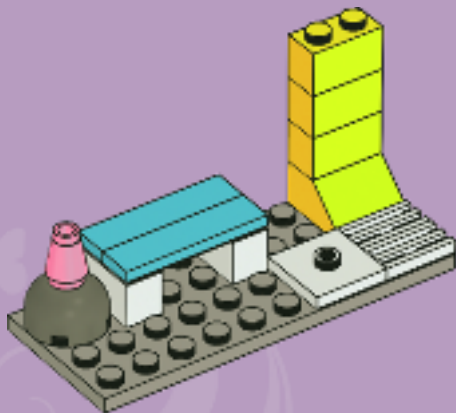

6

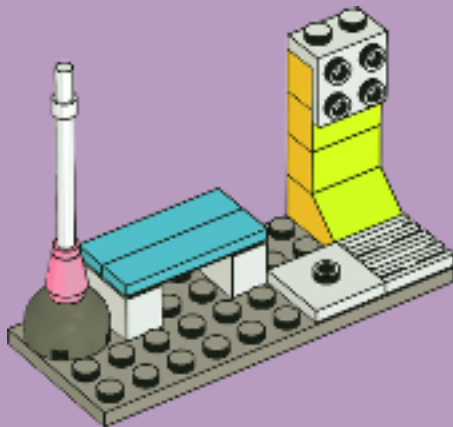



1x



2x



1x

# 7

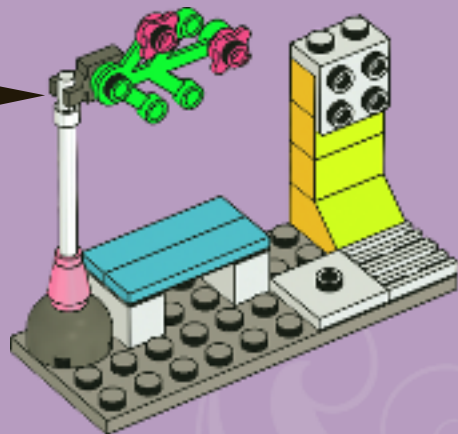

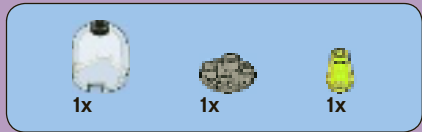

8

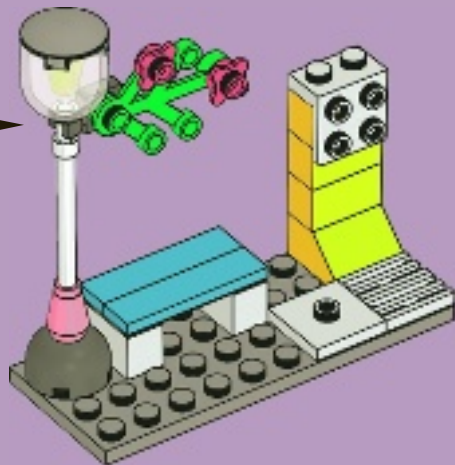





1x



1x

# 9

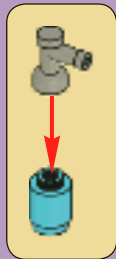

1x



1x

# 10



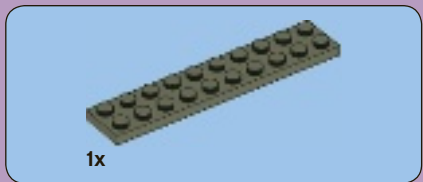

1x

1

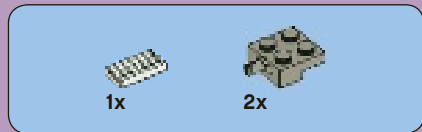

1x

2x

2

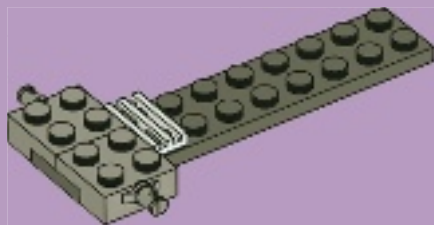



3

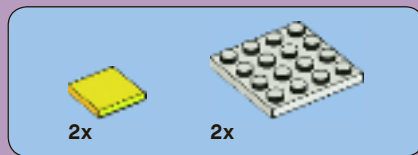
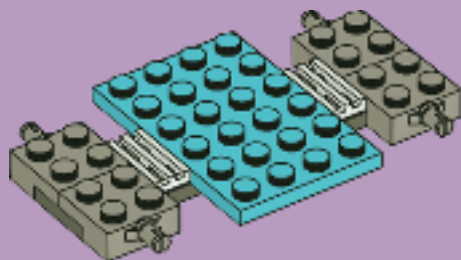

4

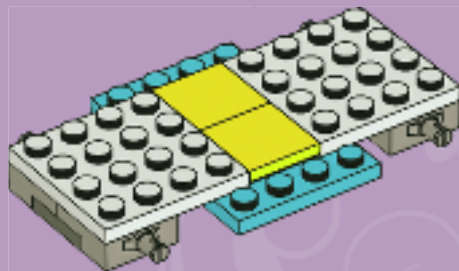



5

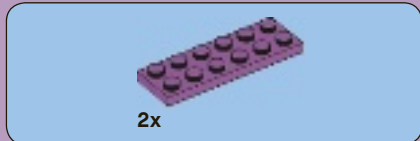
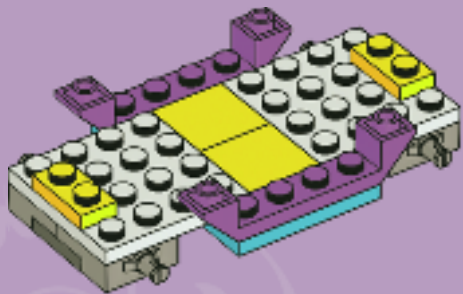

6

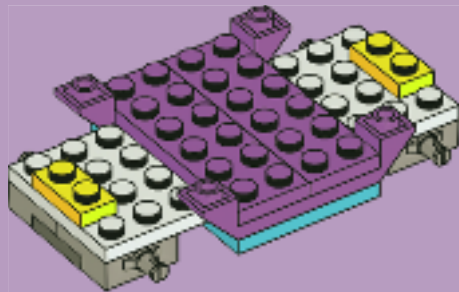



7

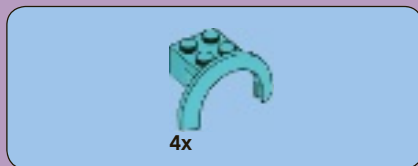
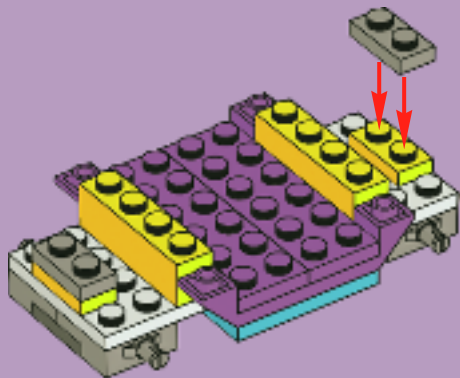

8

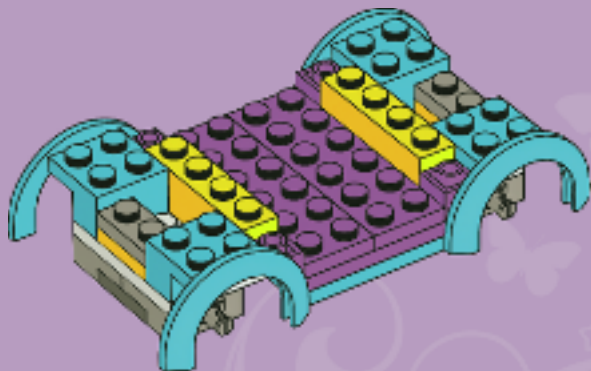



9

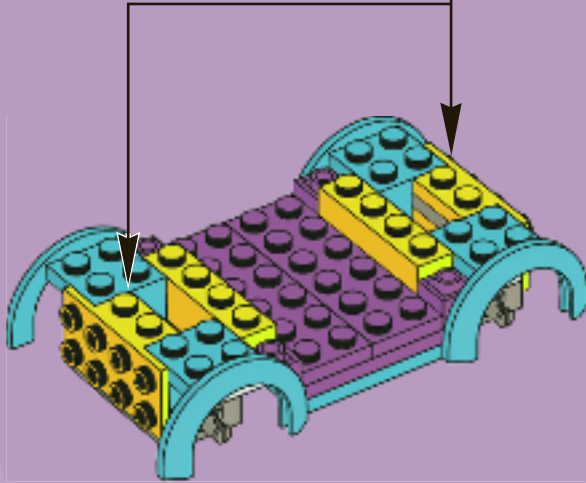



2x



2x

# 10

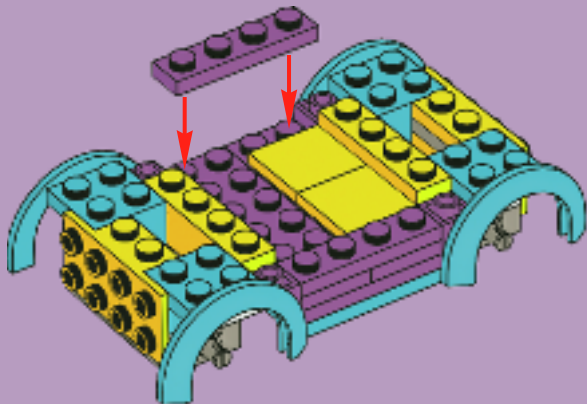



1x



1x

# 11

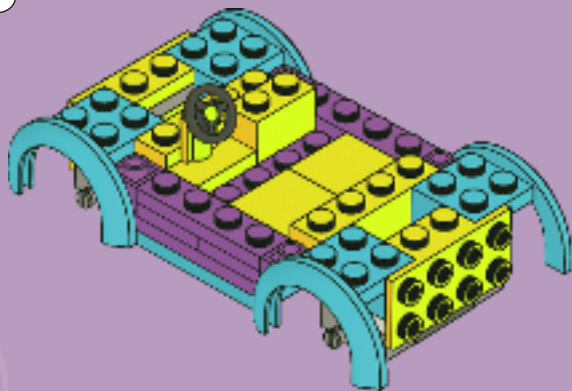
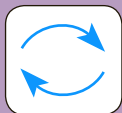





2x

# 12

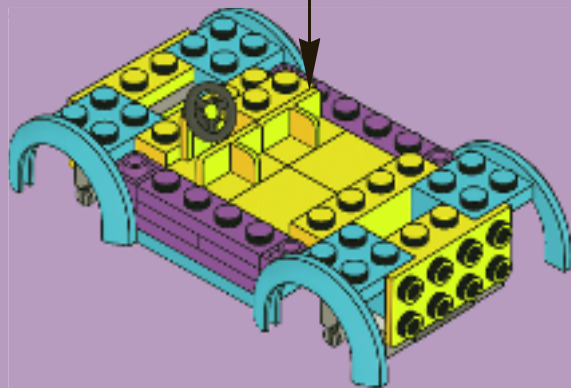

2x

# 13

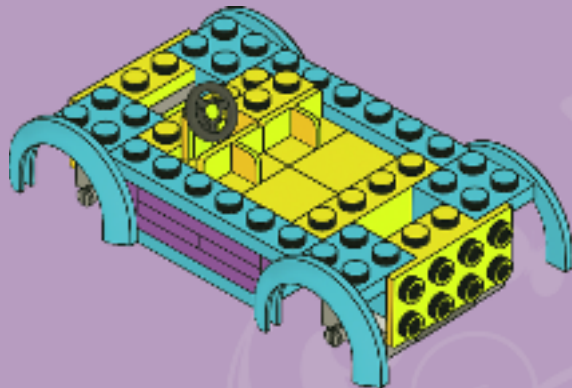



1x

1

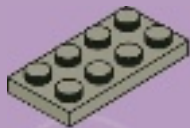

1x

2

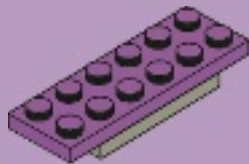



3

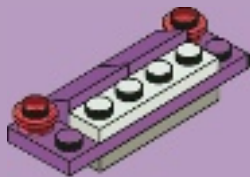

4



5



14

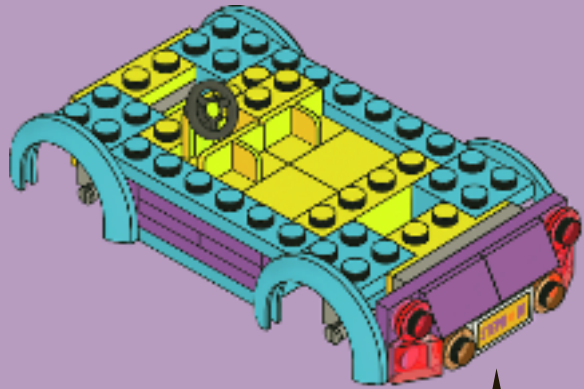



1x

1

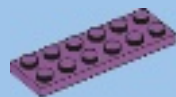
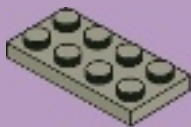

1x

2

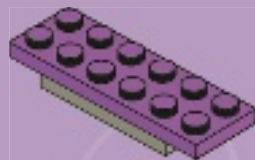



2x



2x

3

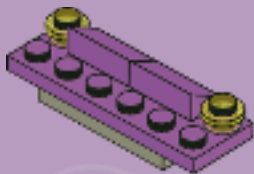

1x



2x

4

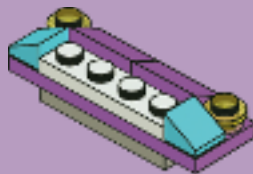



2x

5

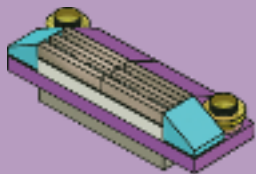

15

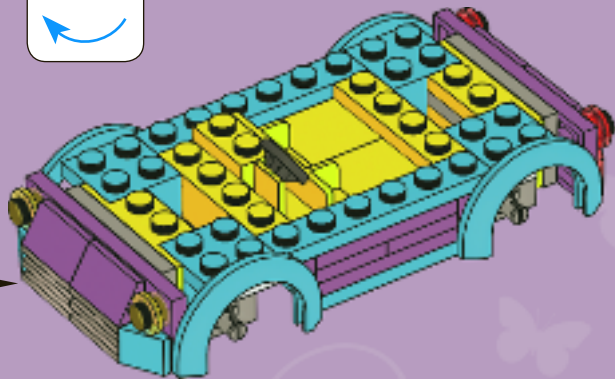
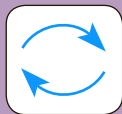

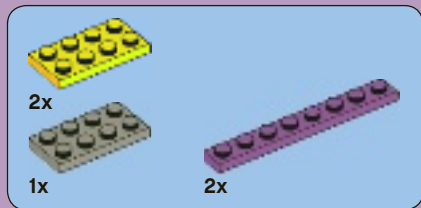

# 16

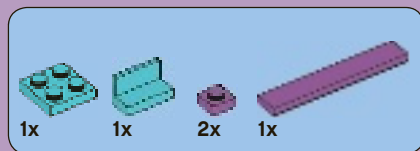
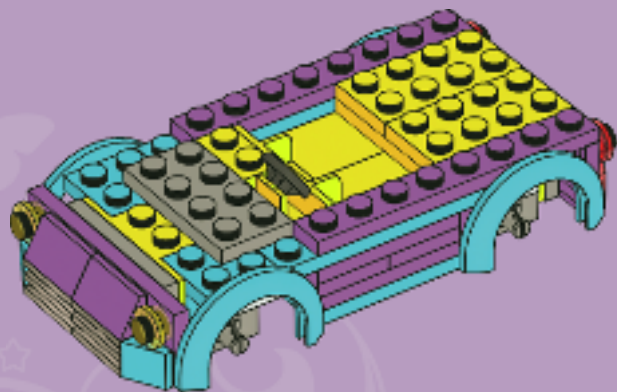

# 17

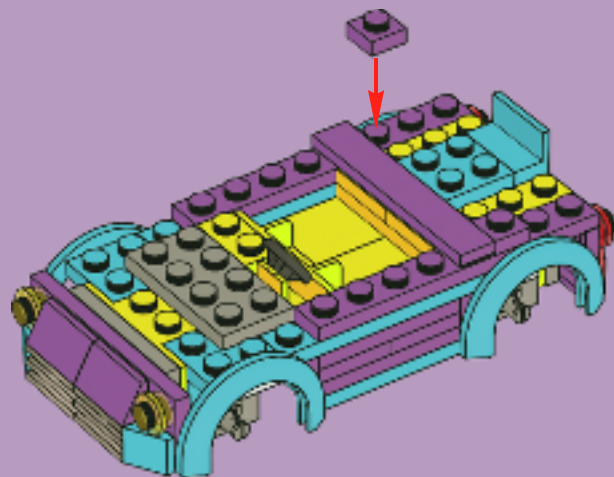





2x



2x

# 18

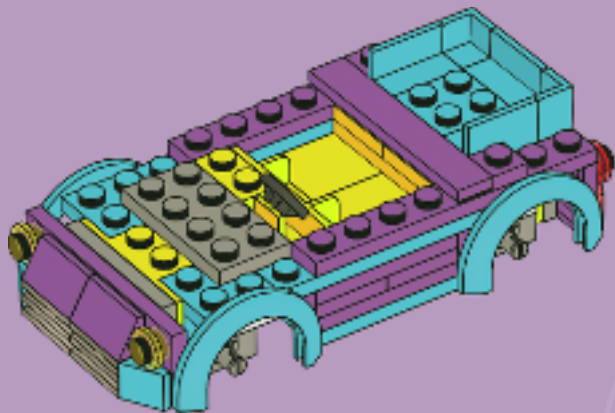



2x

19

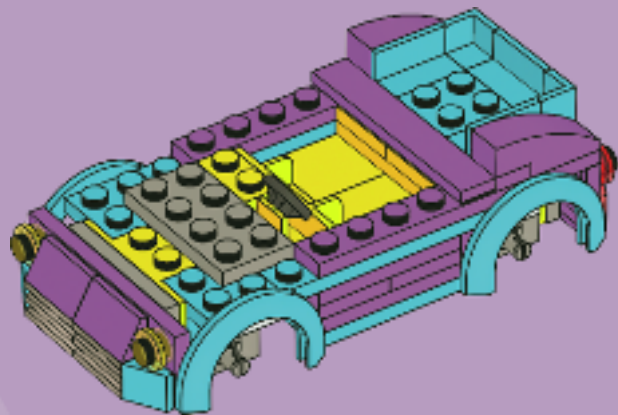



1x



2x



2x

# 20

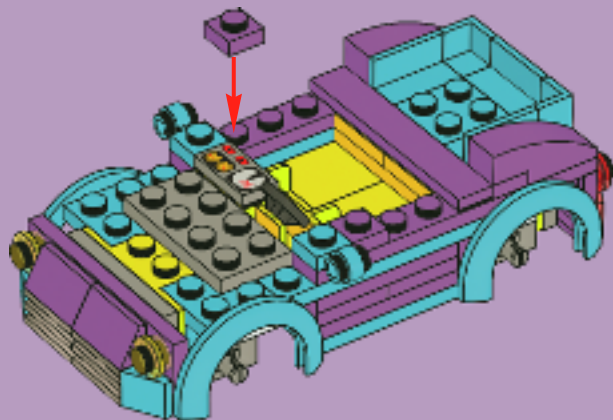

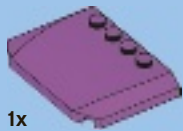

1x

# 21

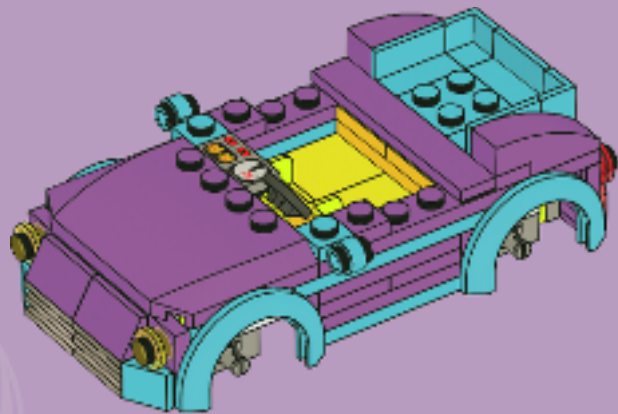

22

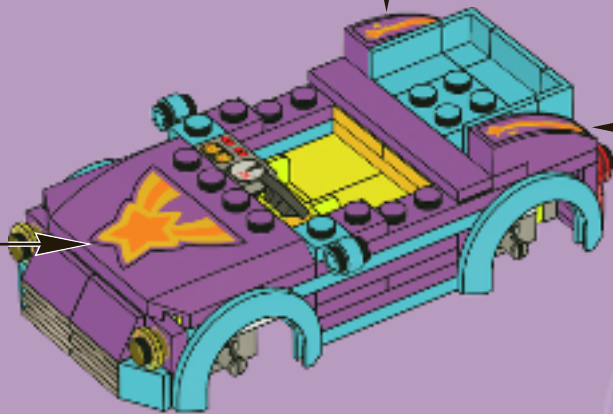



23

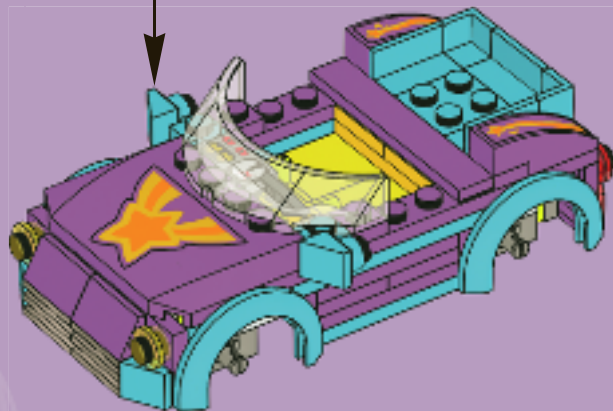

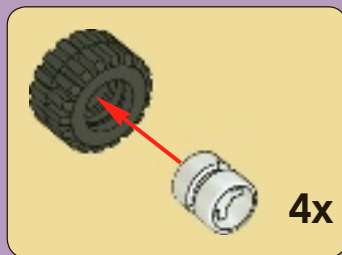
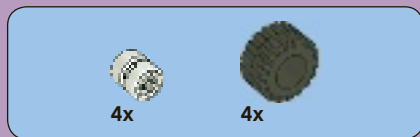

24

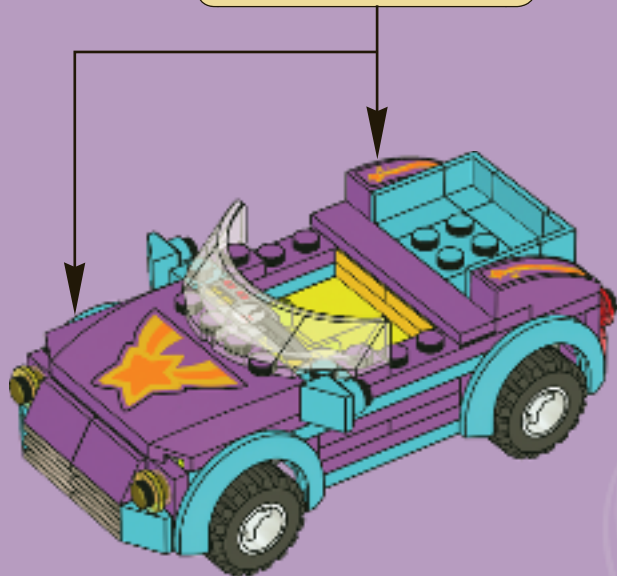







Customer Service

Kundenservice

Service Consommateurs

Servicio Al Consumidor

[www.lego.com/service](http://www.lego.com/service) or dial

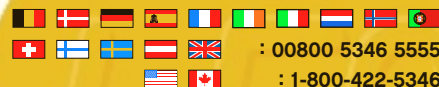

: 00800 5346 5555

: 1-800-422-5346



# Friends

[LEGOFriends.com](http://LEGOFriends.com)





3183



3061



3065



3942



3188



3936





# Heartlake City



**LEGO** Friends

**LEGO** Friends



LEGOFriends.com







# CREATOR

5766



5771



5770



creator.LEGO.com





[www.LEGOclub.com](http://www.LEGOclub.com)



LEGO® Club Email



LEGO® Club Magazine

**LEGO** club™

**FREE! GRATIS! GRATUIT!**

**SIGN UP ONLINE!**

**[www.LEGOclub.com](http://www.LEGOclub.com)**



**00800 5346 5555\***



**1-866-534-6258 • 1-877-518-5346**

US & Canada only

One-time enrollment

- \* Freephone. Mobile charges may apply.
- \* Numéro sans frais. Des frais peuvent s'appliquer avec les téléphones cellulaires.
- \* Gebührenfrei, Kosten für Anrufe aus Mobilfunknetzen können abweichen.
- \* Gratis telefonnummer vanaf vaste lijn.
- \* Det er et gratis nummer, når du ringer fra fasttelefon.
- \* Det är gratis, när du ringer från en fast telefon.
- \* Numéro sans frais. Des frais peuvent s'appliquer avec les téléphones portables.



# Win!

Go to [www.LEGOsurvey.com/product](http://www.LEGOsurvey.com/product) to fill out a survey for a chance to win a cool LEGO® Product. No purchase necessary. Open to all residents where not prohibited.

## [www.LEGOsurvey.com](http://www.LEGOsurvey.com)

### Gewinne!

Nimm an der Umfrage auf [www.LEGOsurvey.com/product](http://www.LEGOsurvey.com/product) teil und hab die Chance ein cooles LEGO® Produkt zu gewinnen! Die Teilnahme am Gewinnspiel führt zu keinerlei Kaufverpflichtungen. Teilnahme in allen nicht abgeschlossenen Ländern möglich.

### Win!

Ga naar [www.LEGOsurvey.com/product](http://www.LEGOsurvey.com/product), vul een enquêteformulier in en maak kans op een cool LEGO® product. Geen aankoopverplichting. Iedereen mag deelnemen, uitgezonderd ingezetenden van landen waar een enquêteverbod geldt.

### Gagn

Visite [www.LEGOsurvey.com/product](http://www.LEGOsurvey.com/product) pour questionnaire chance de gagner un produit LEGO® très cool. Aucune obligation. Ouvert à tous les résidents autorisés.



[www.LEGO.com](http://www.LEGO.com)

6006118

LEGO and the L

