

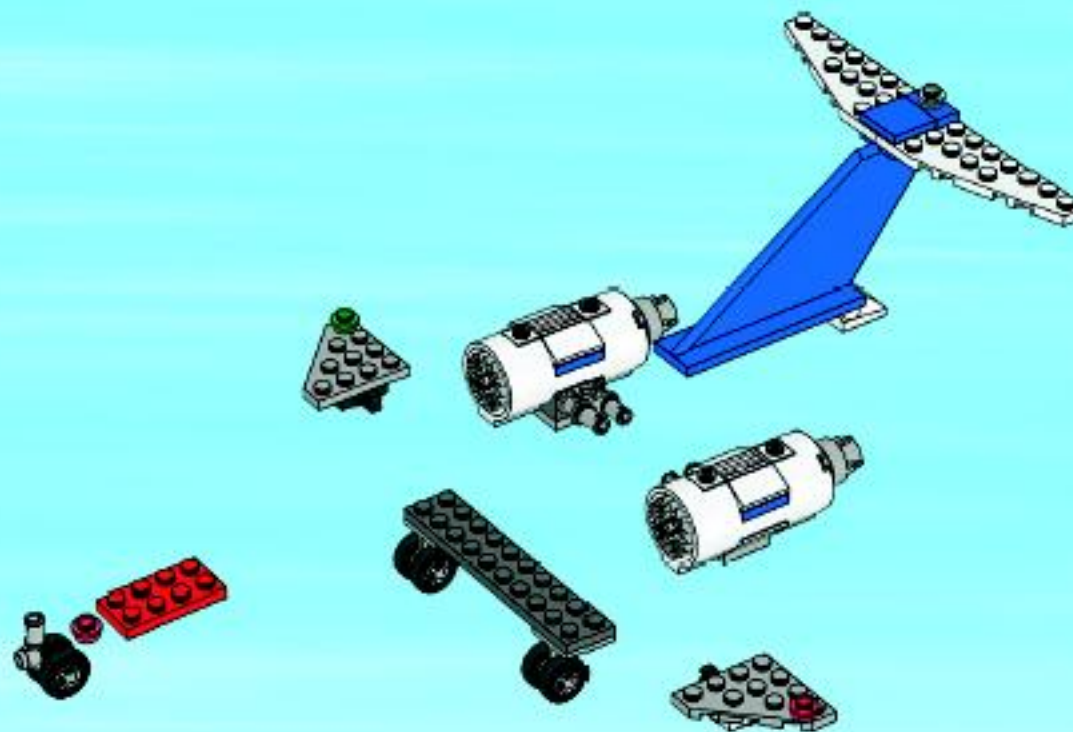

3181

CITY

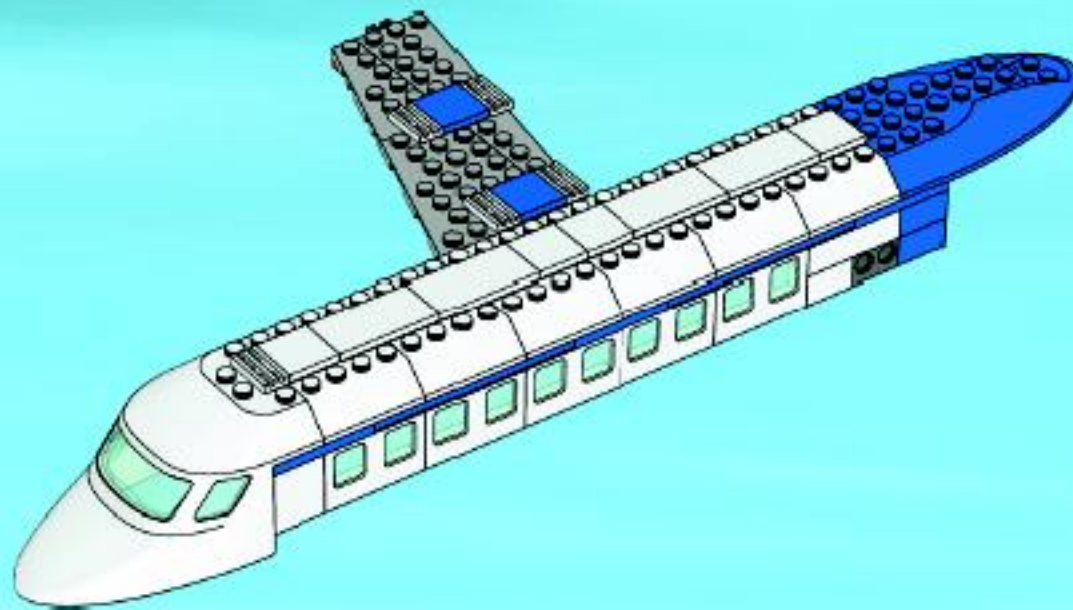

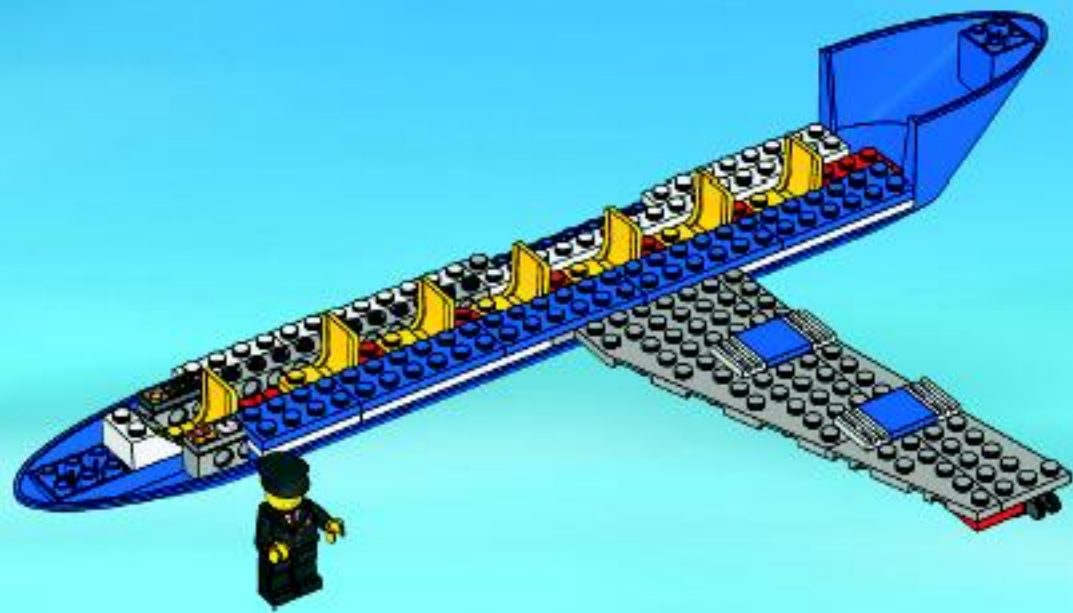

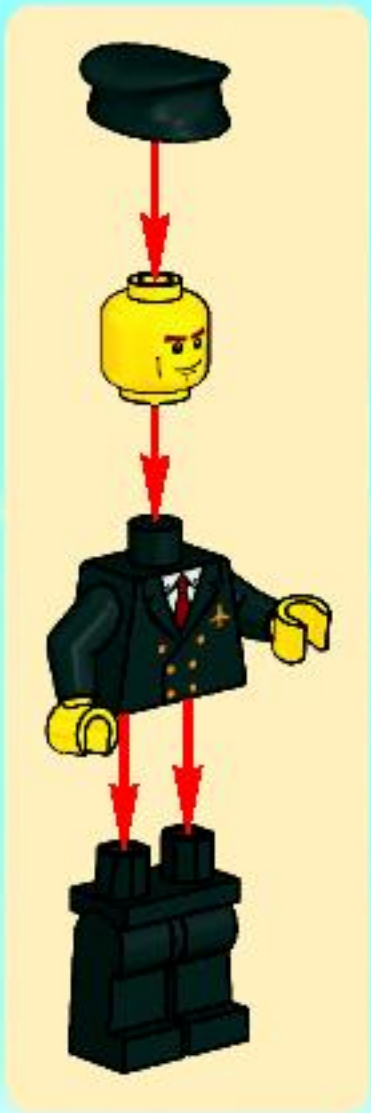
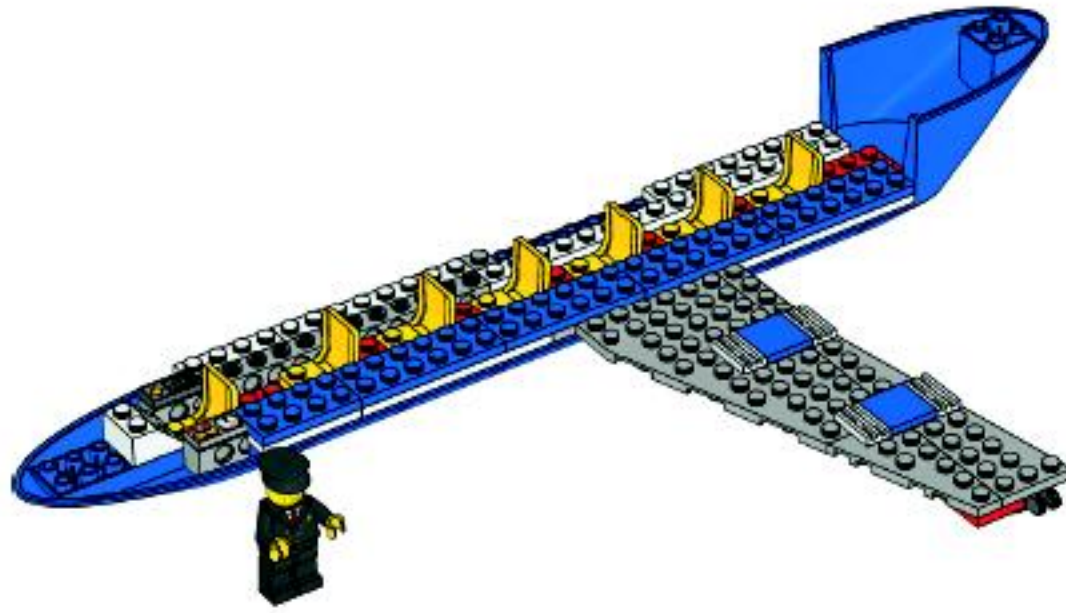

1

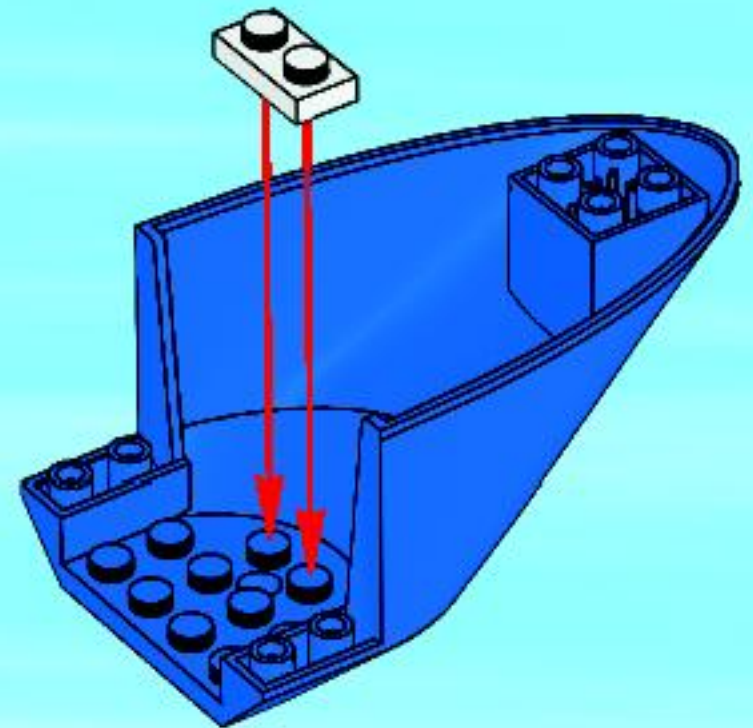

2

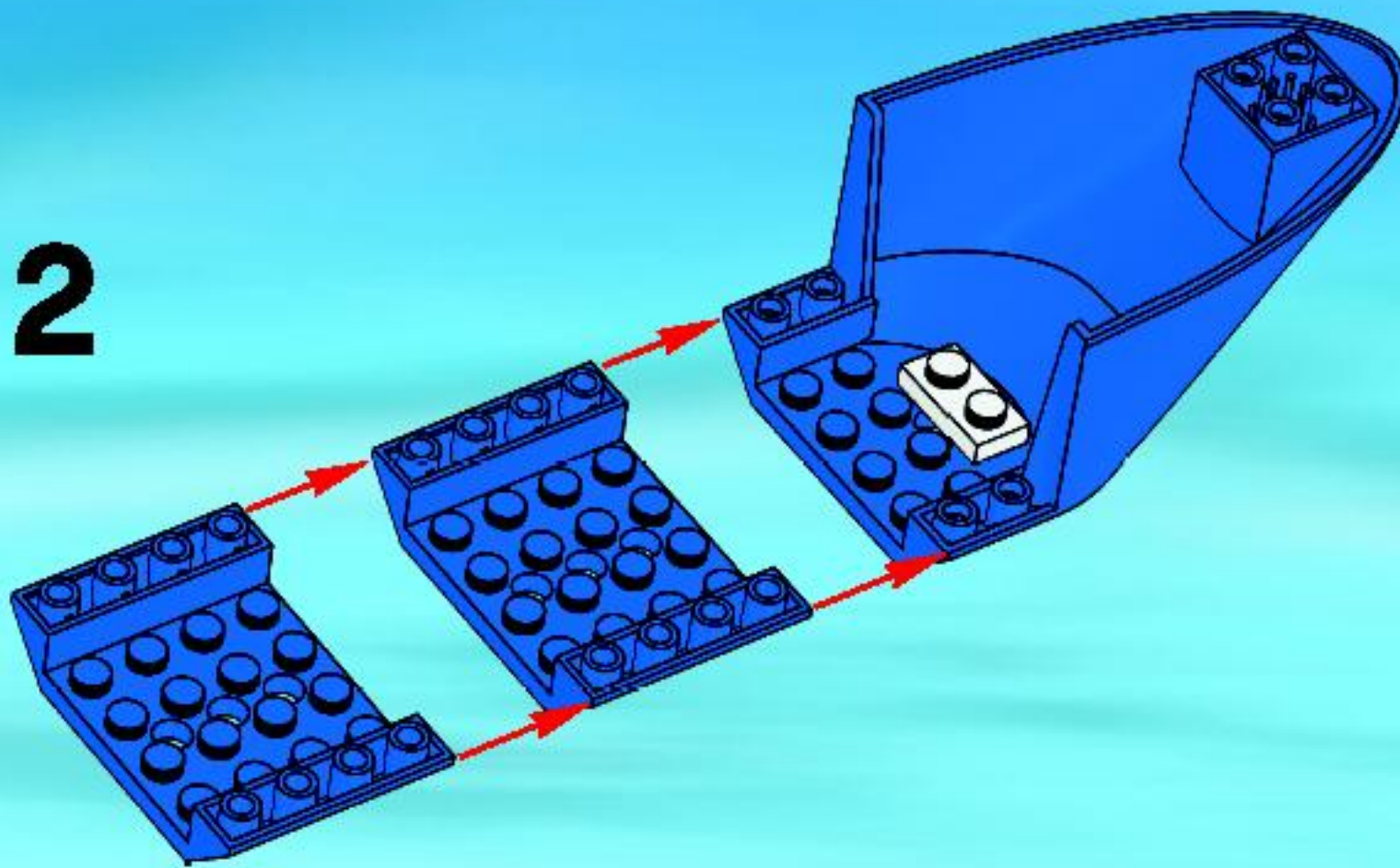

3

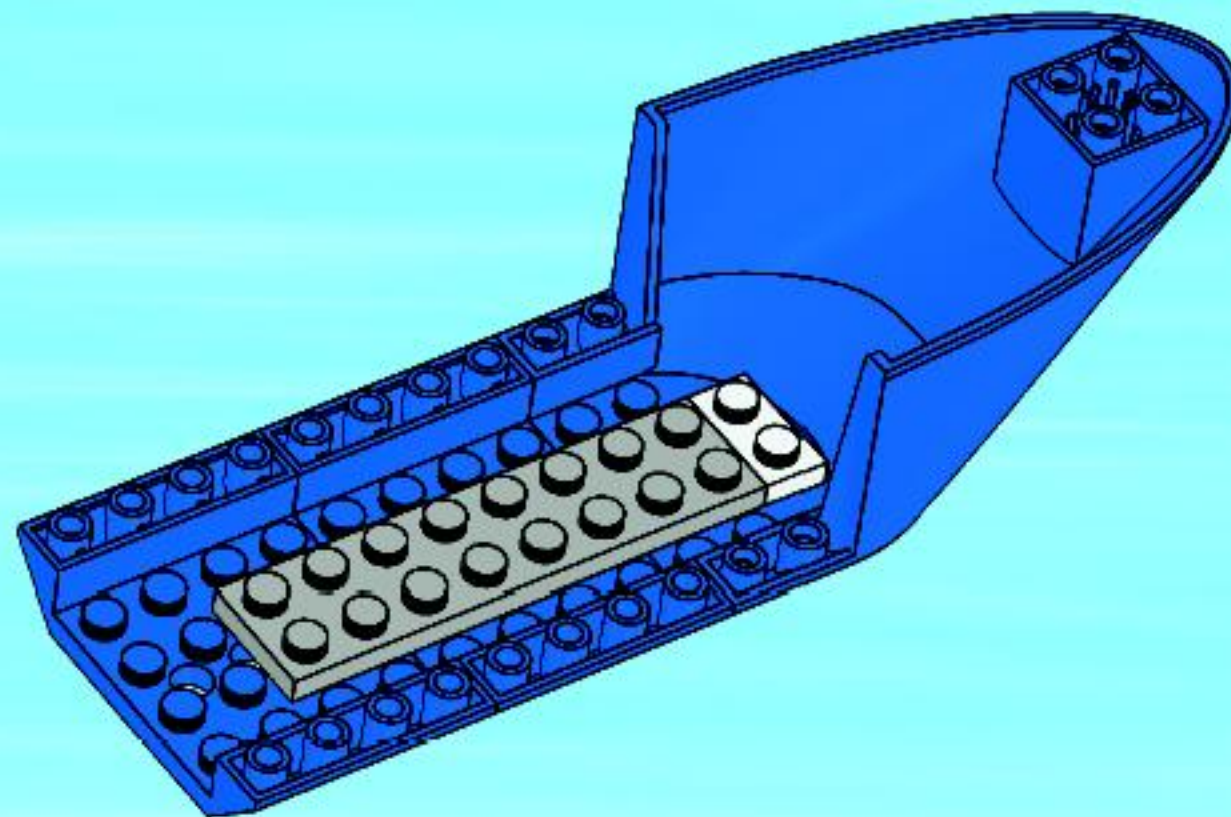

4

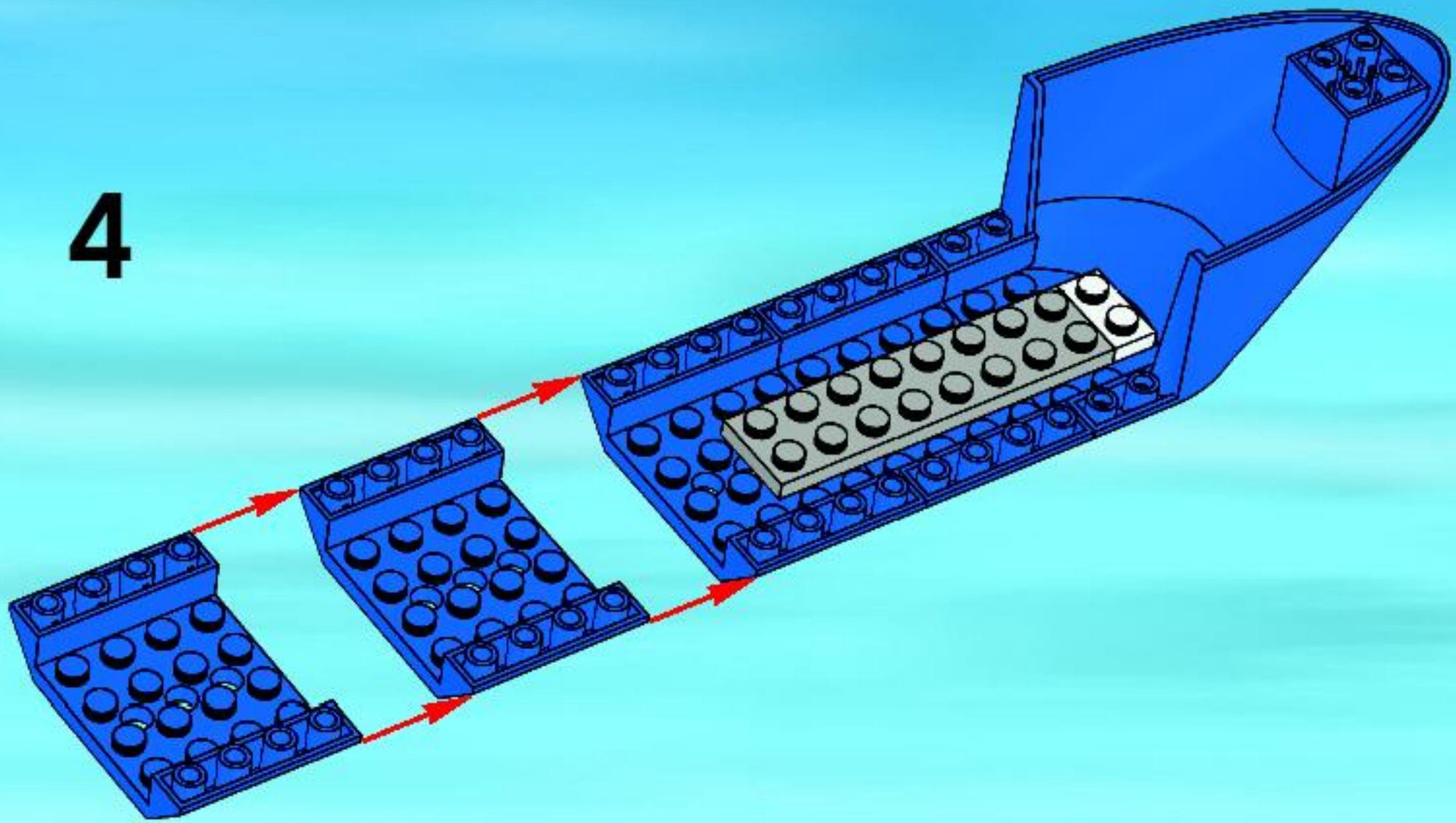

5

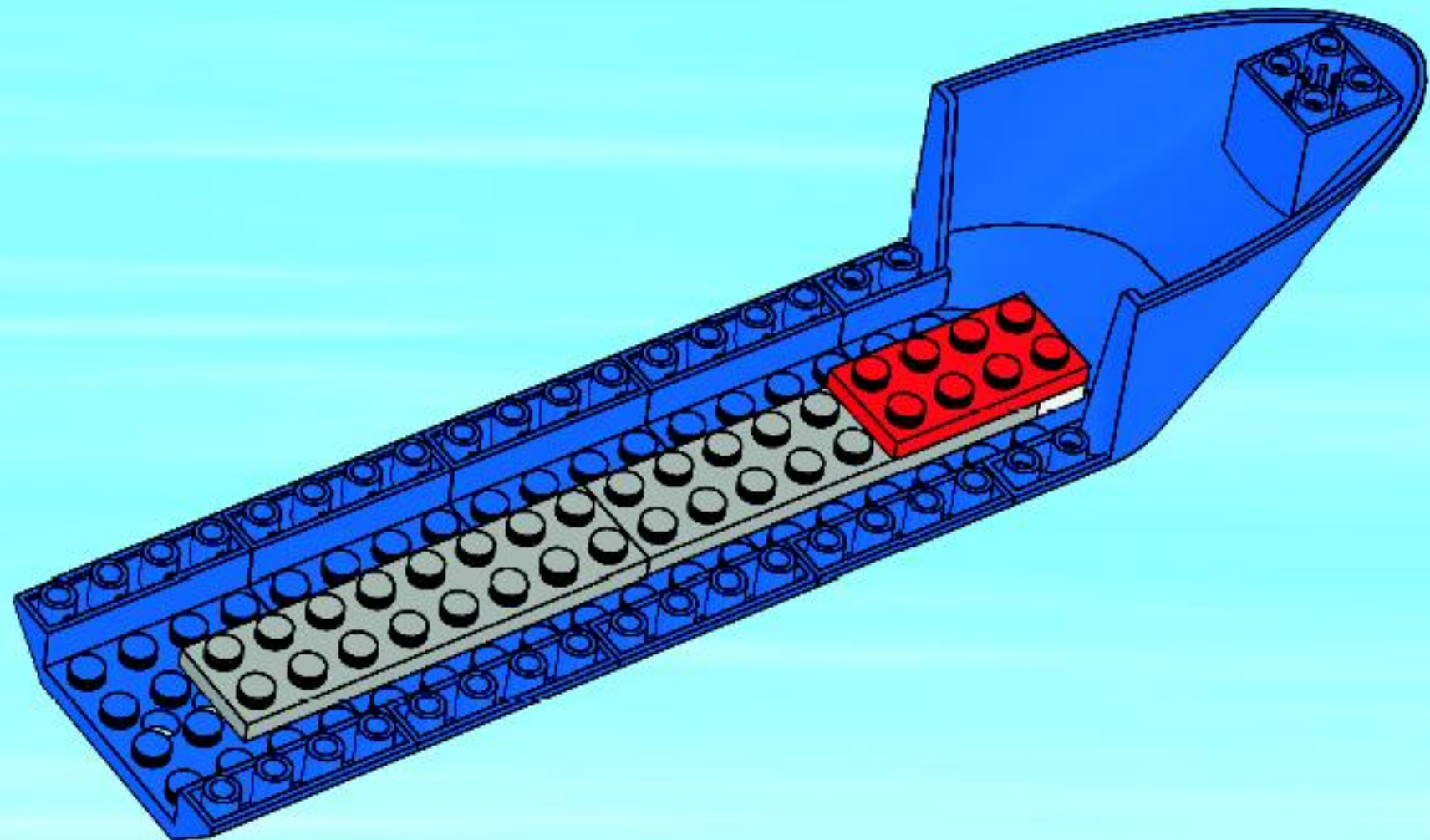

6

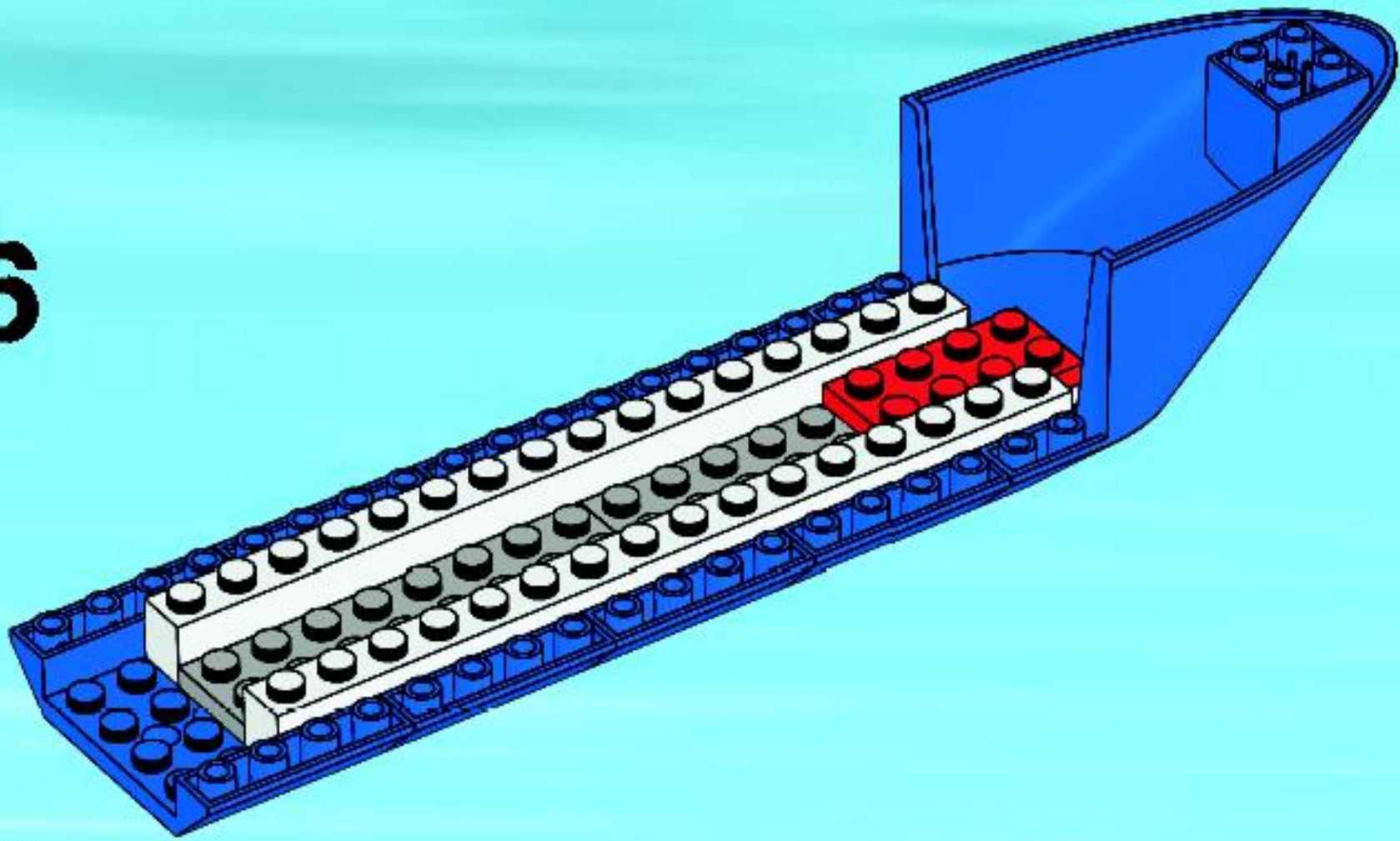

7

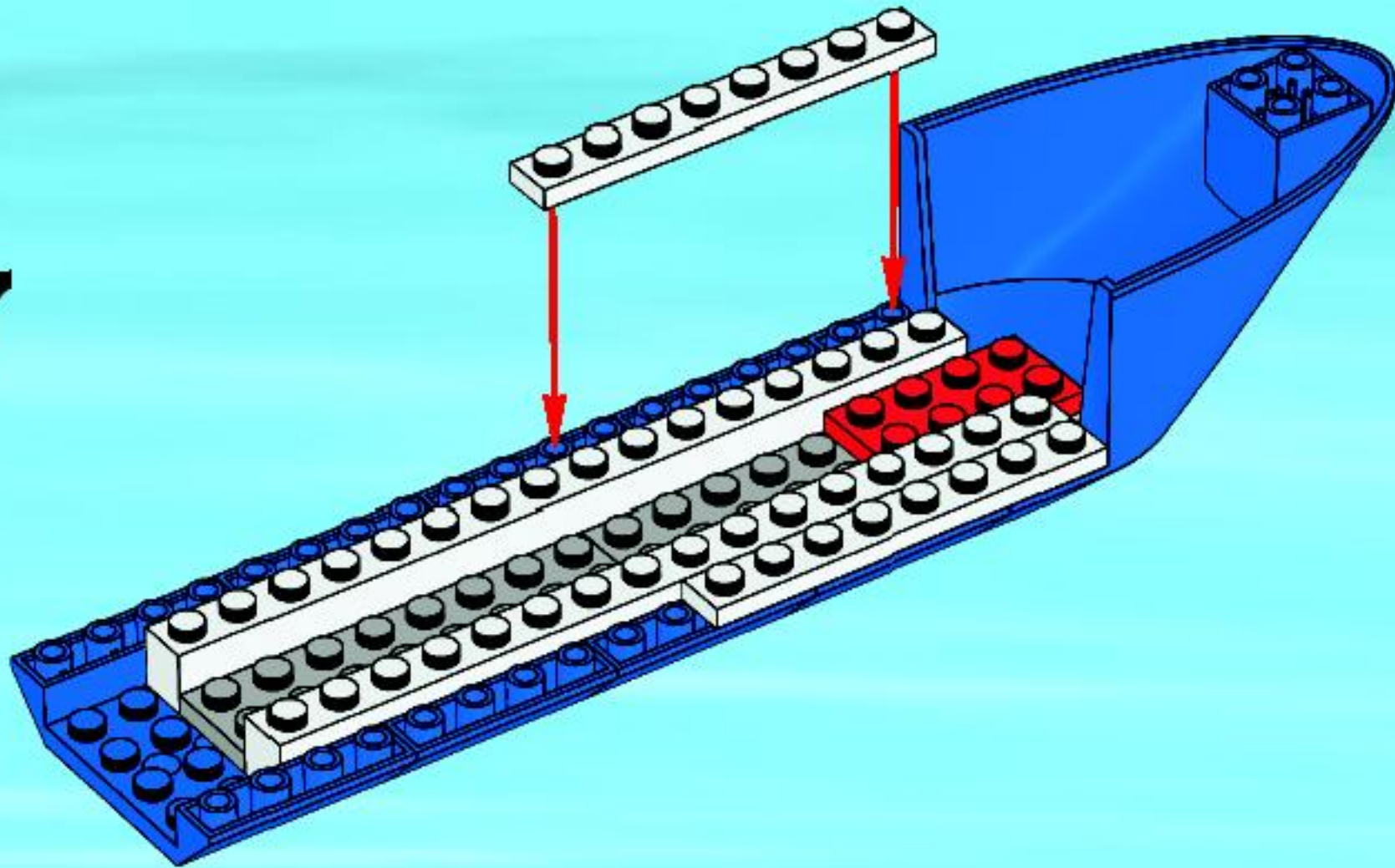

8

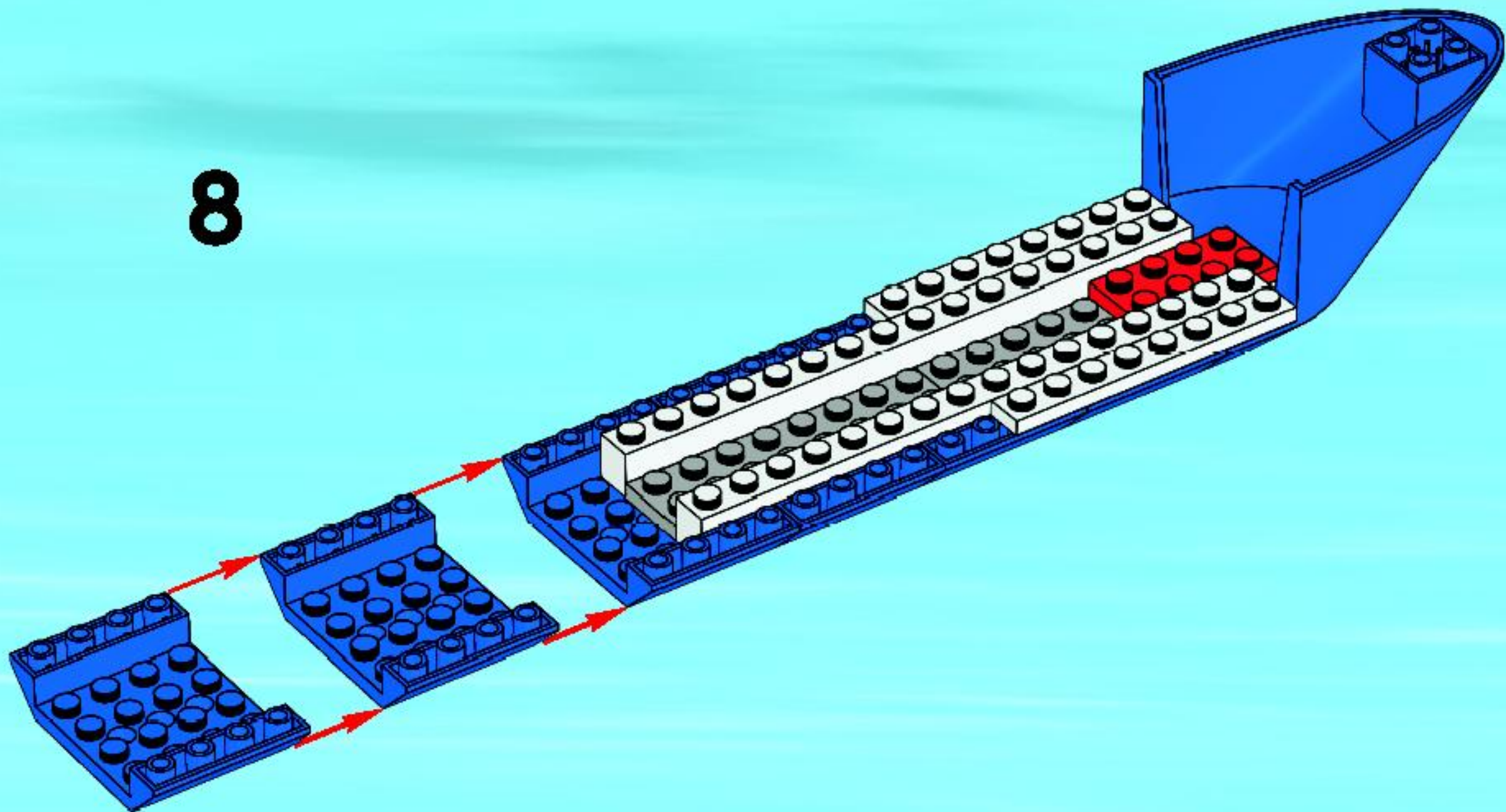

9

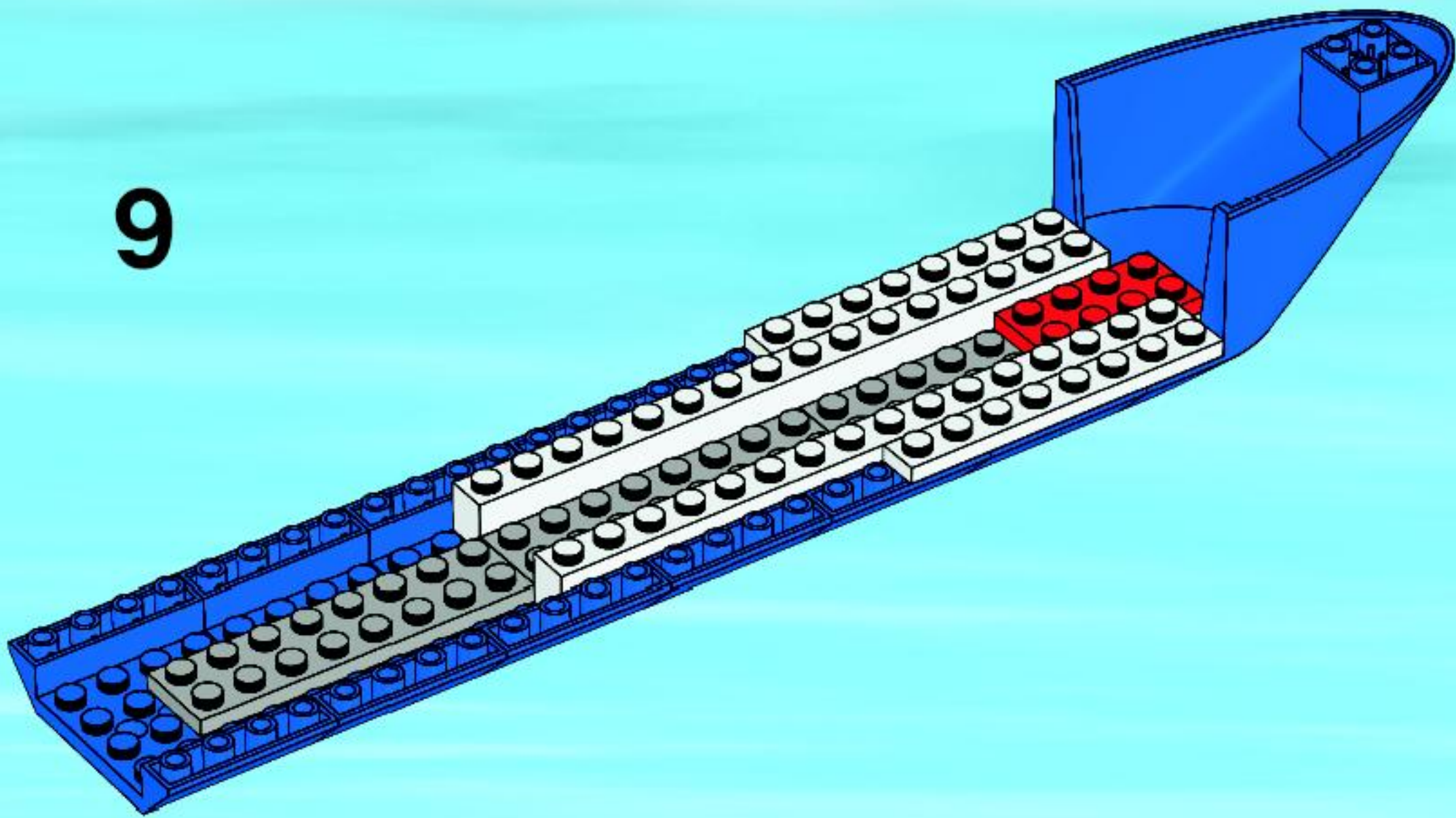

10

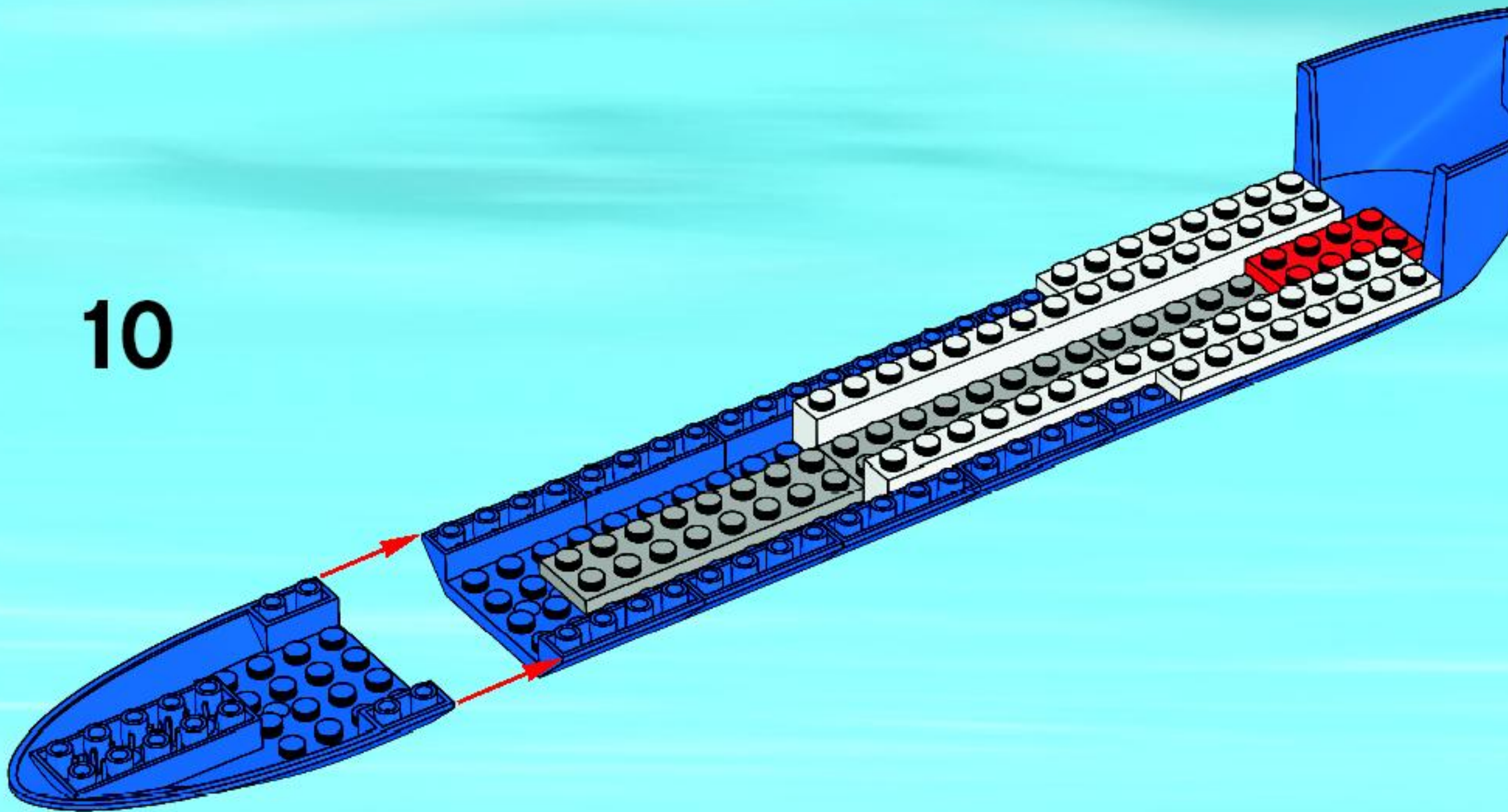

11

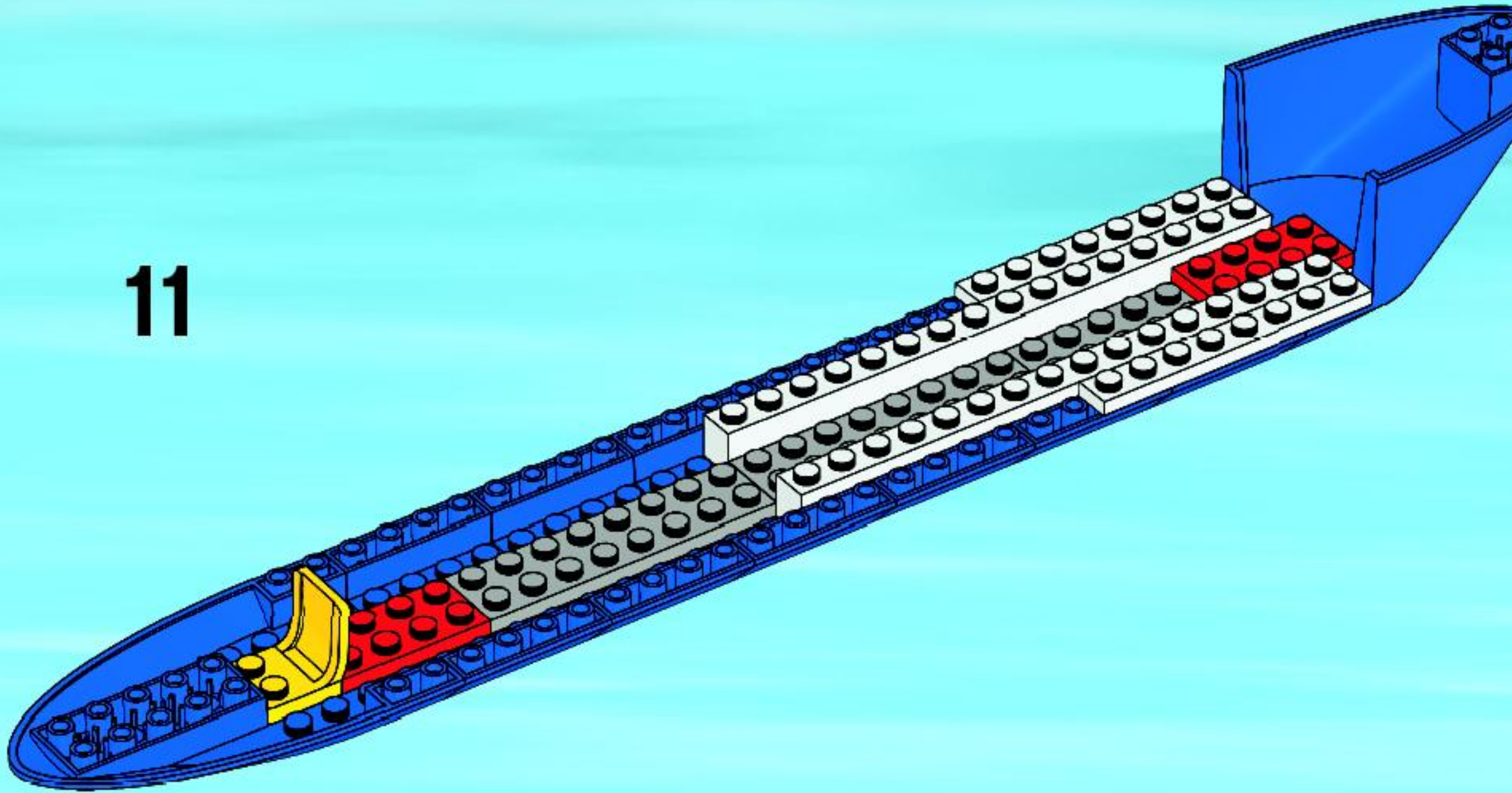

12

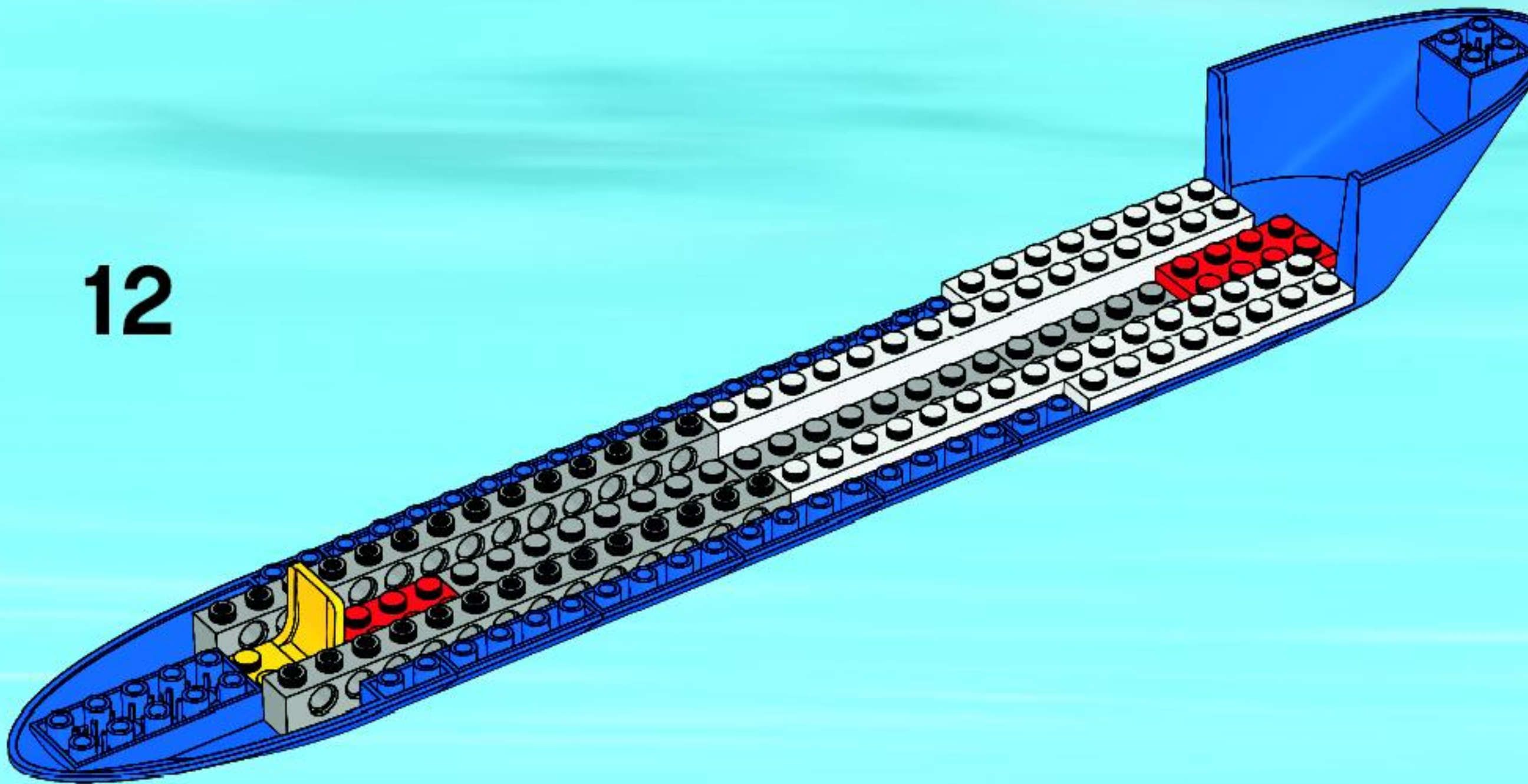

13

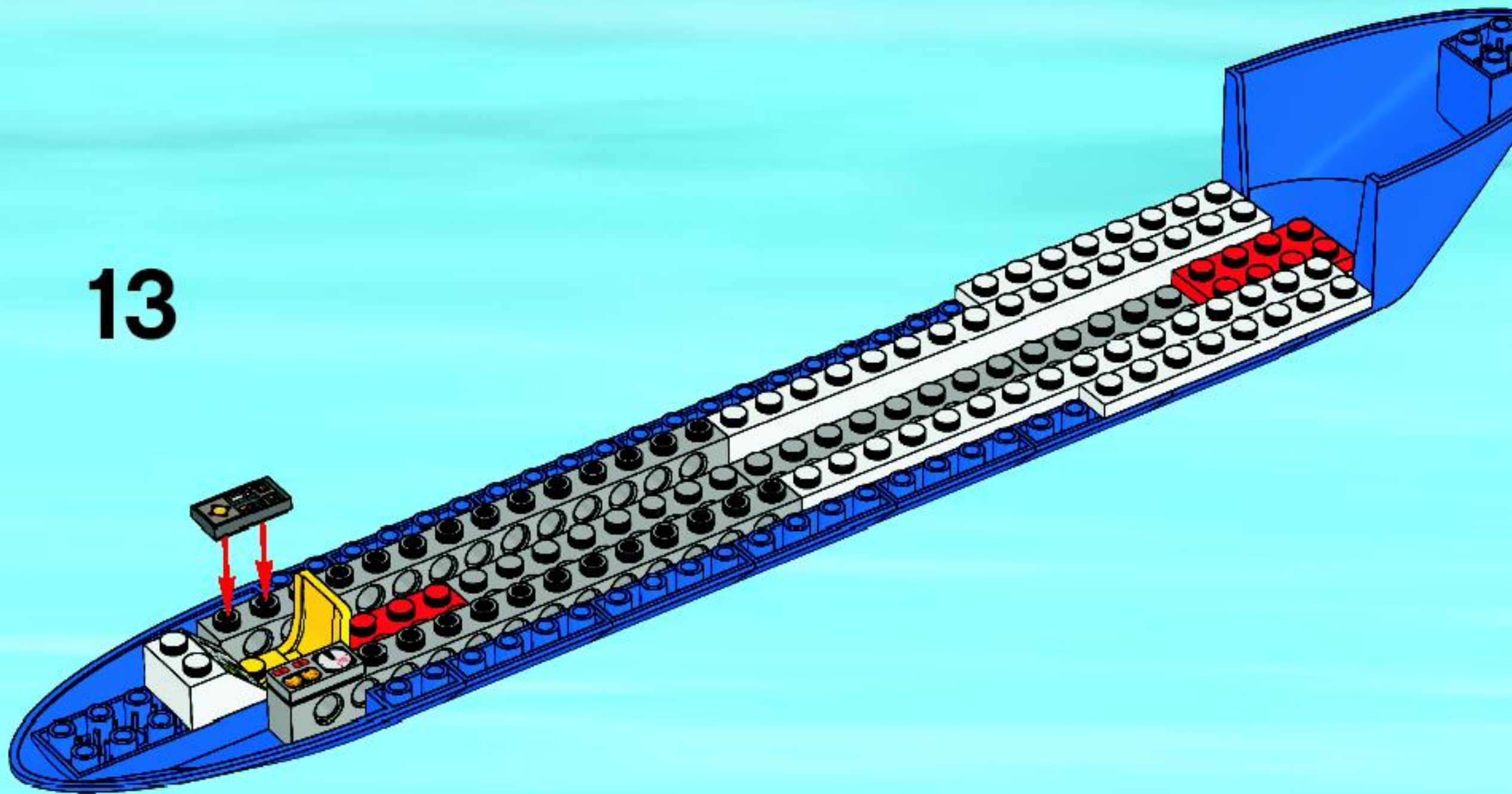

14

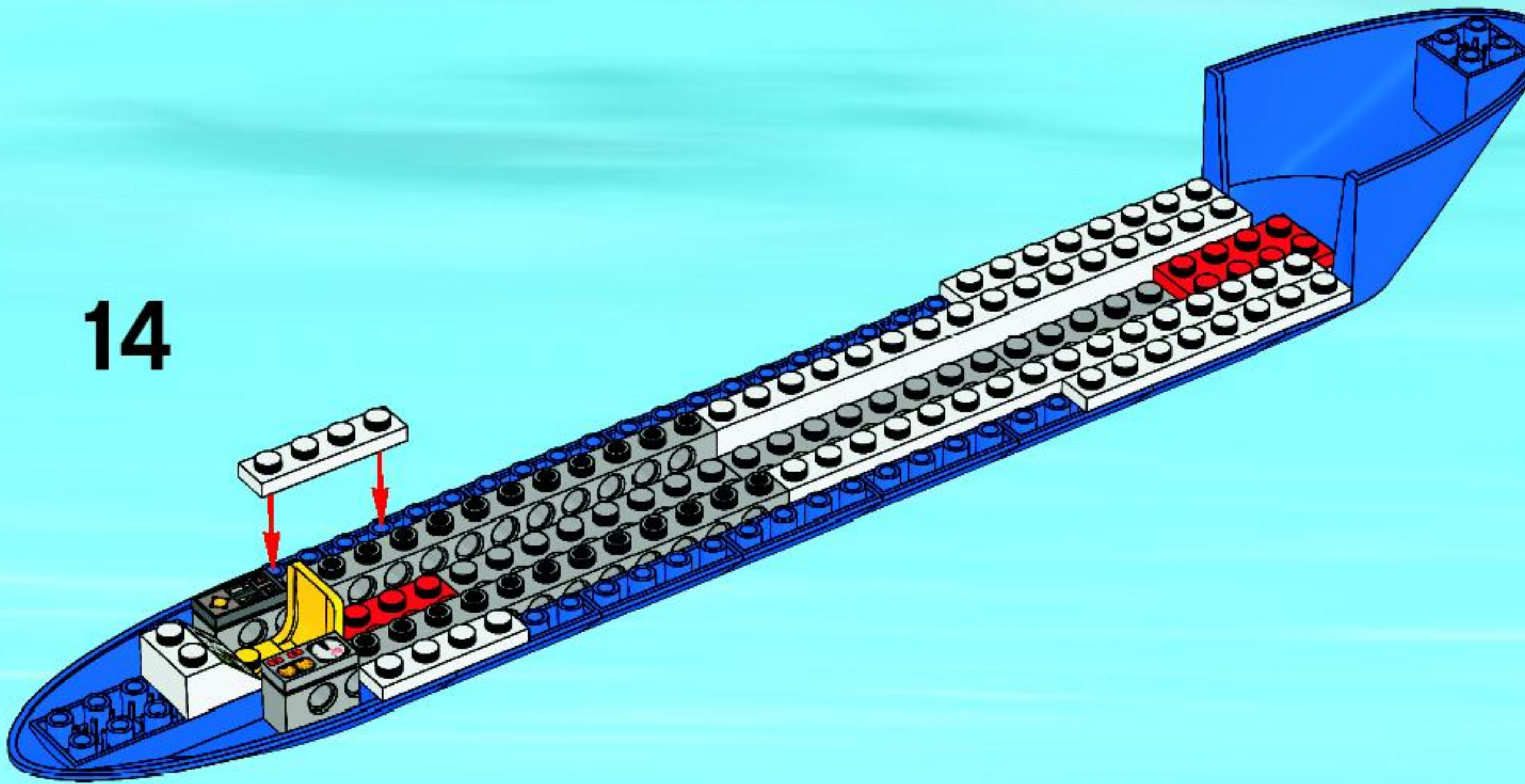

15

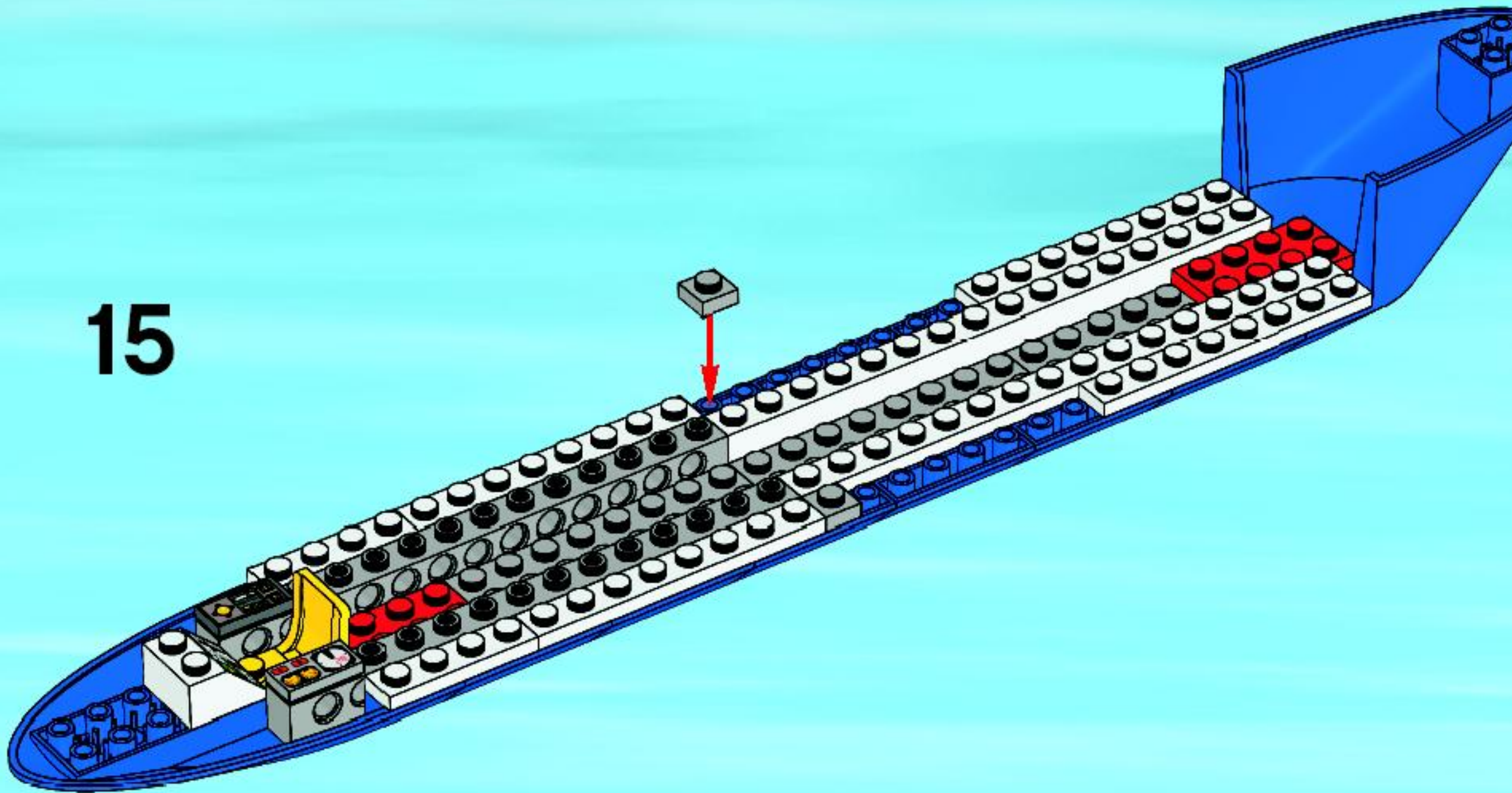

16

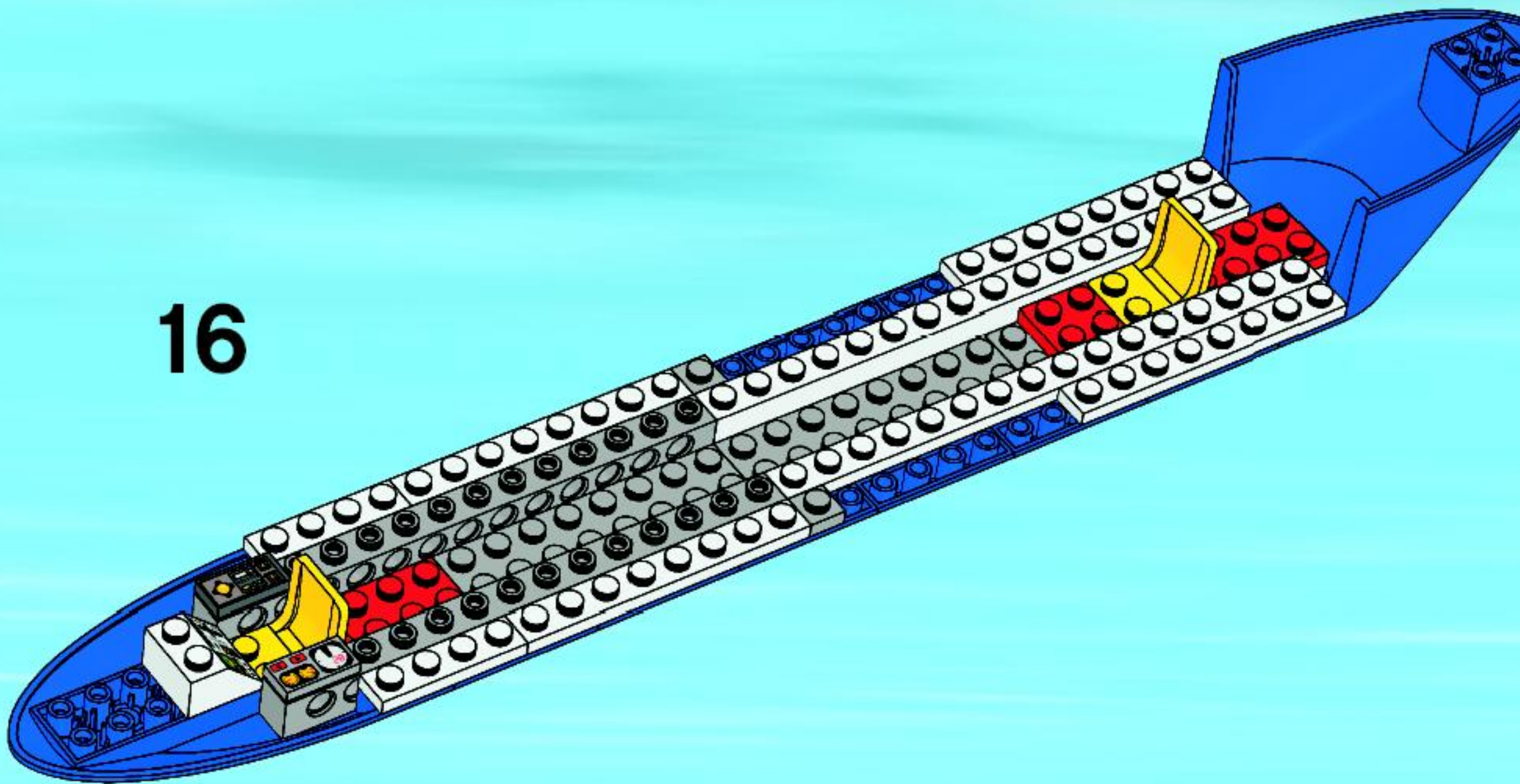

17

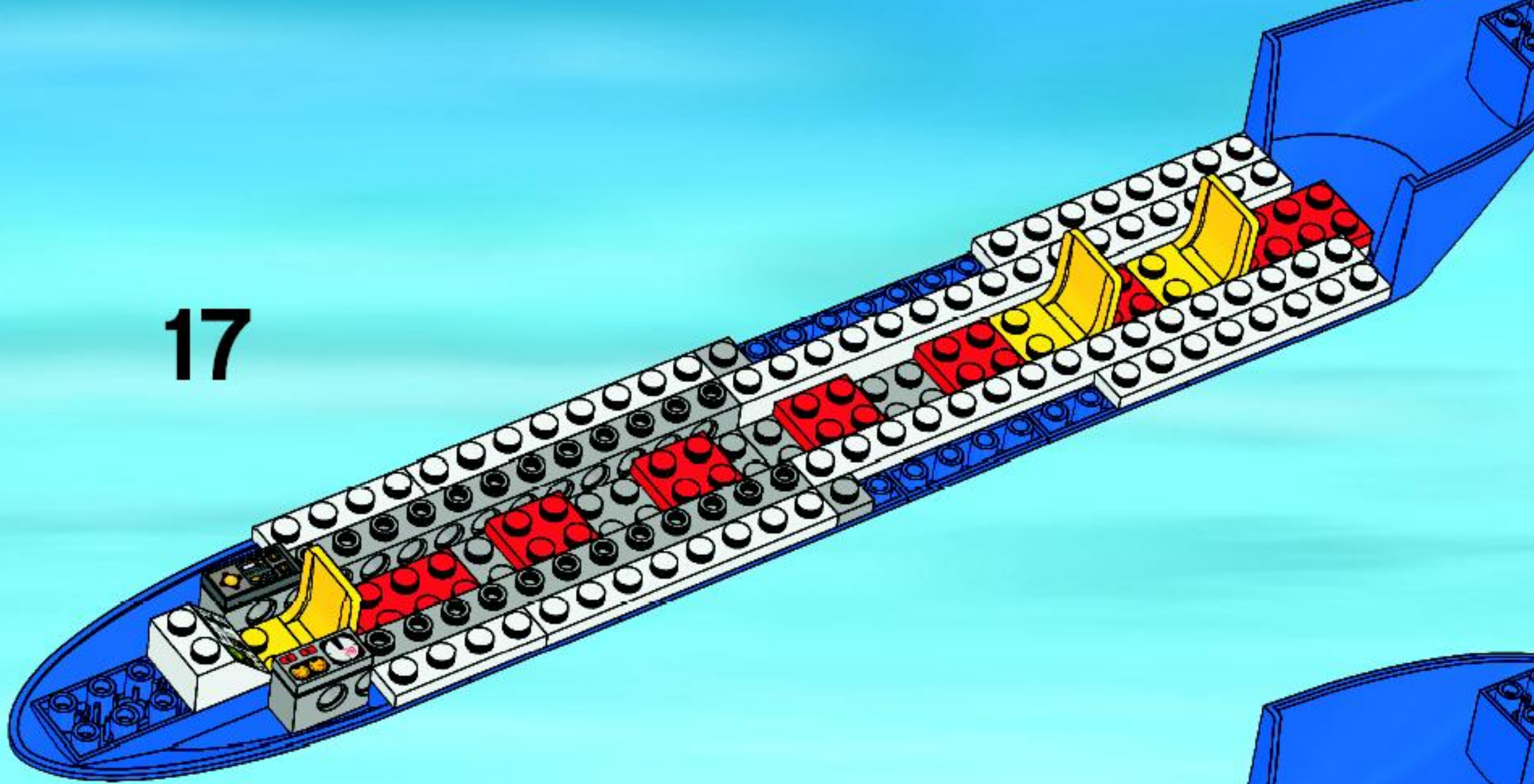

18

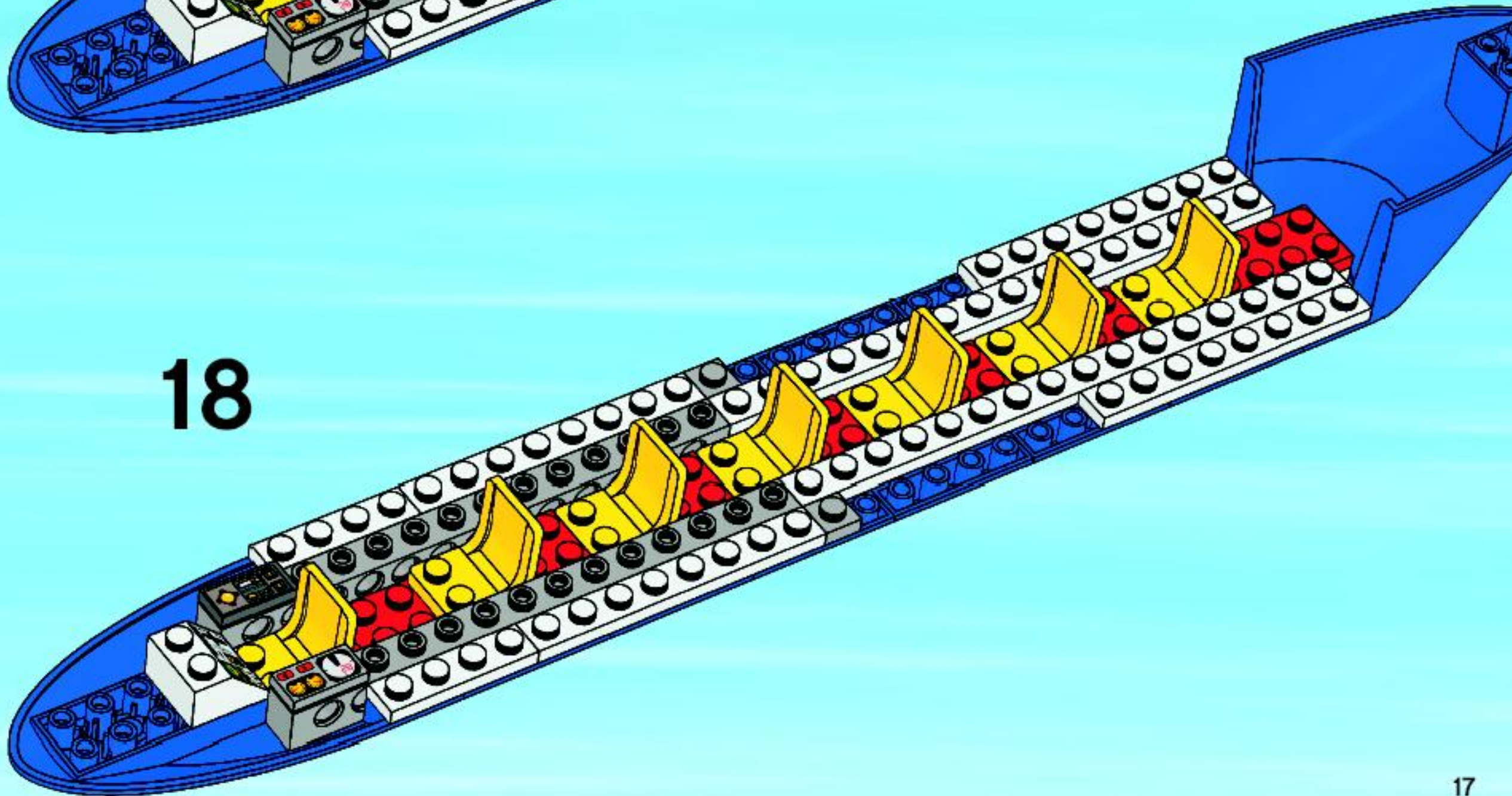

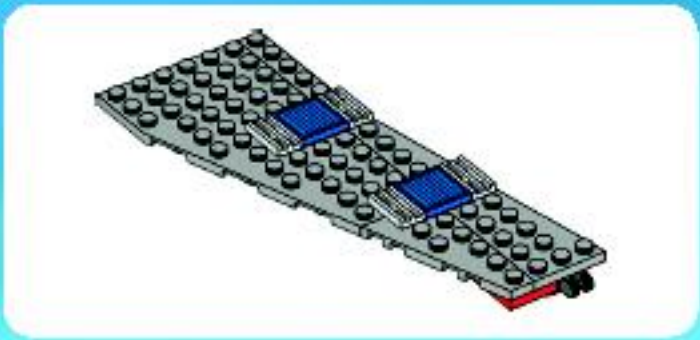

1

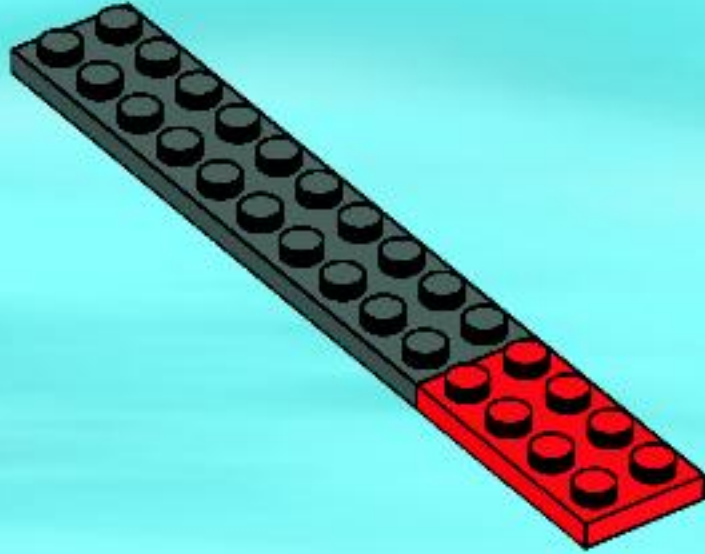

2

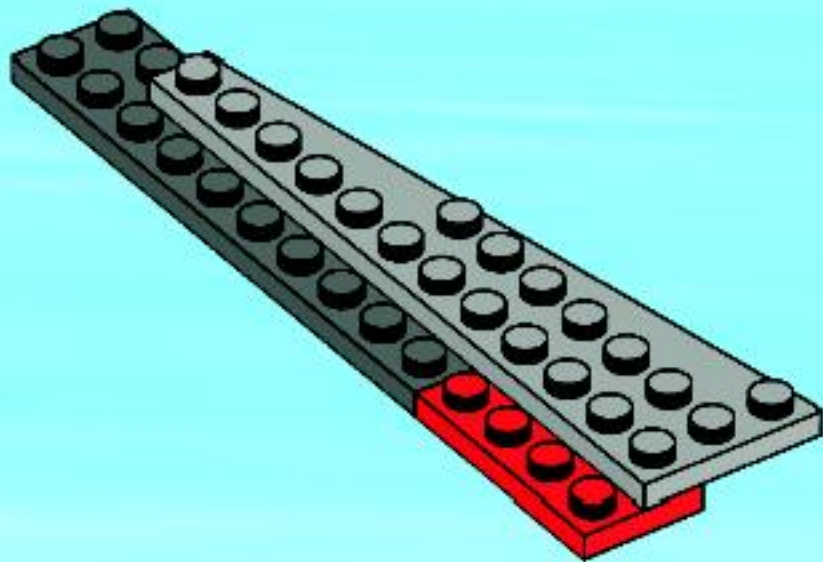

3

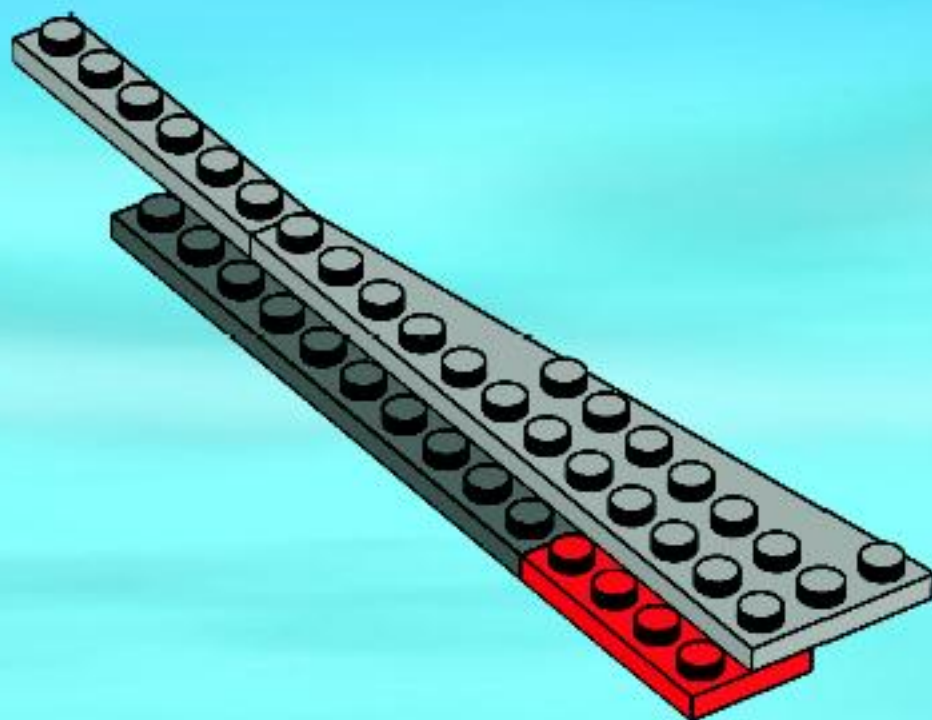

4

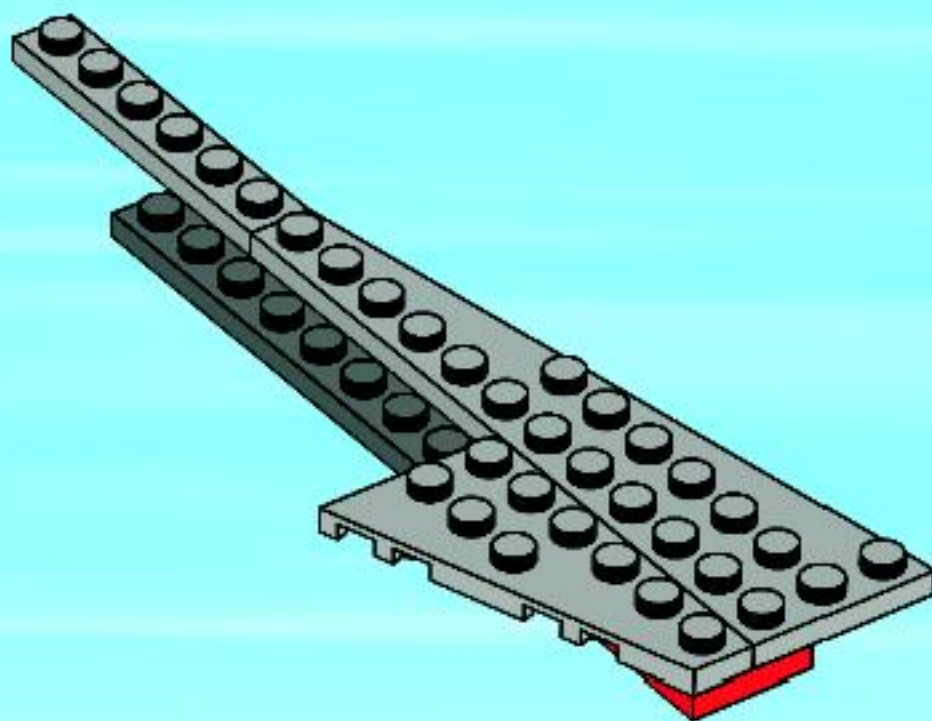

5

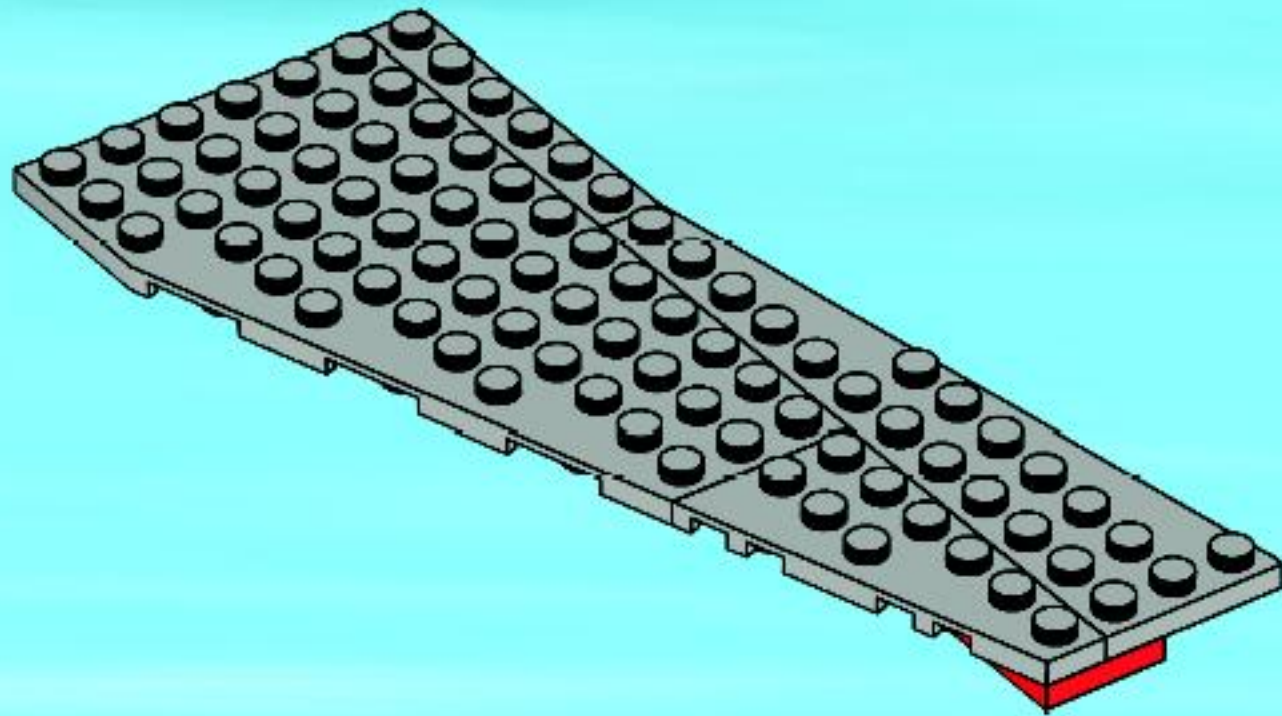

6

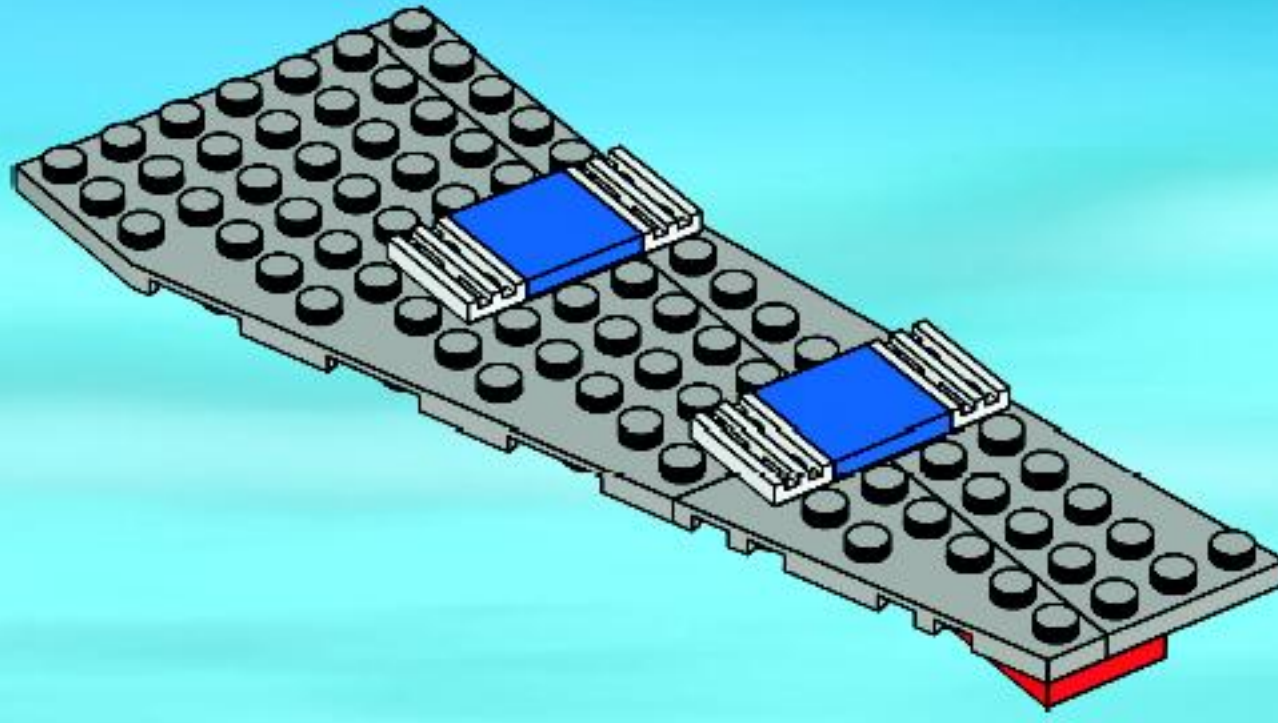

7

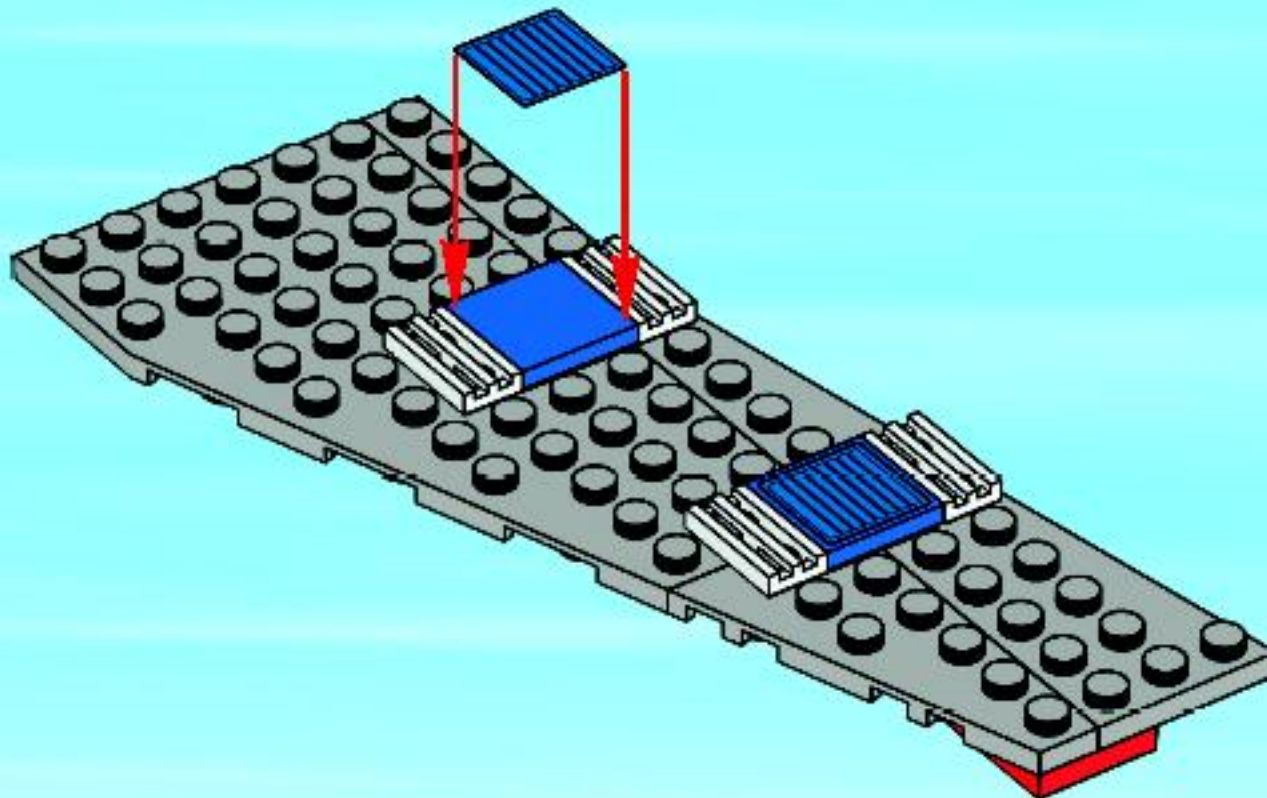

8

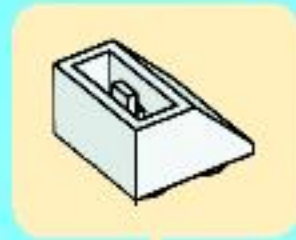
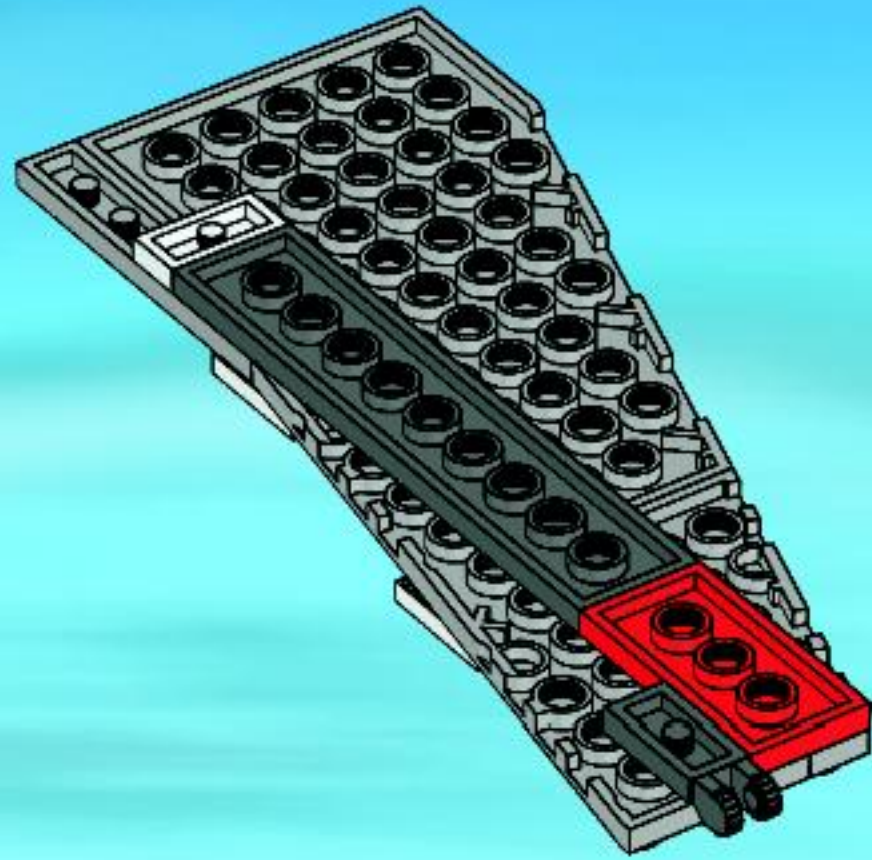

9

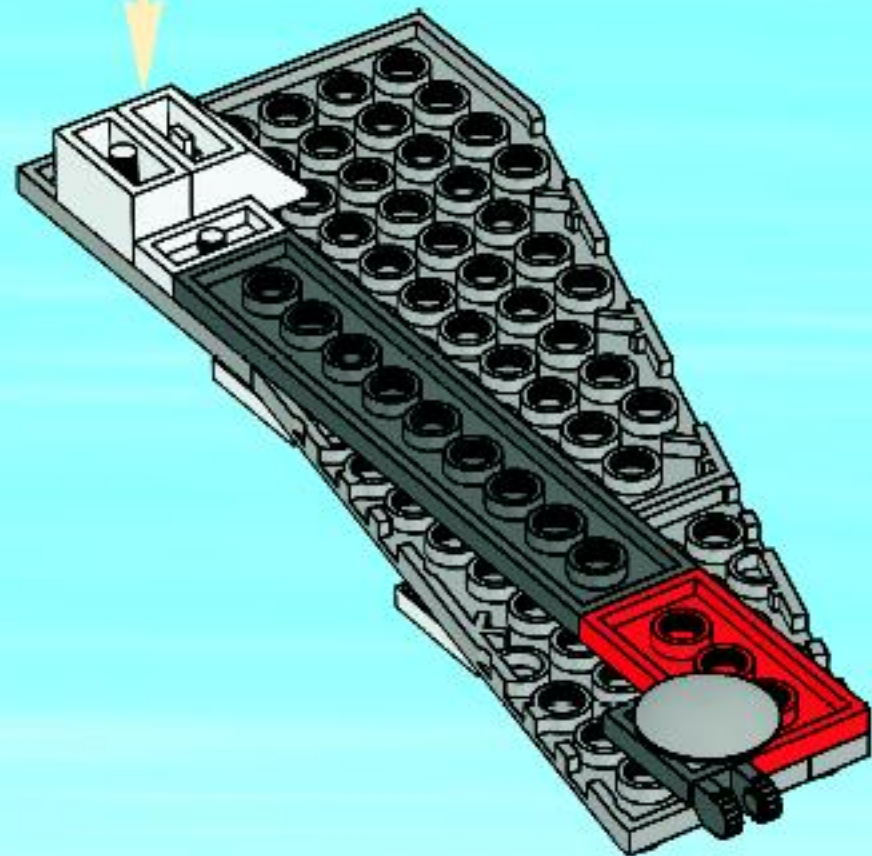

10

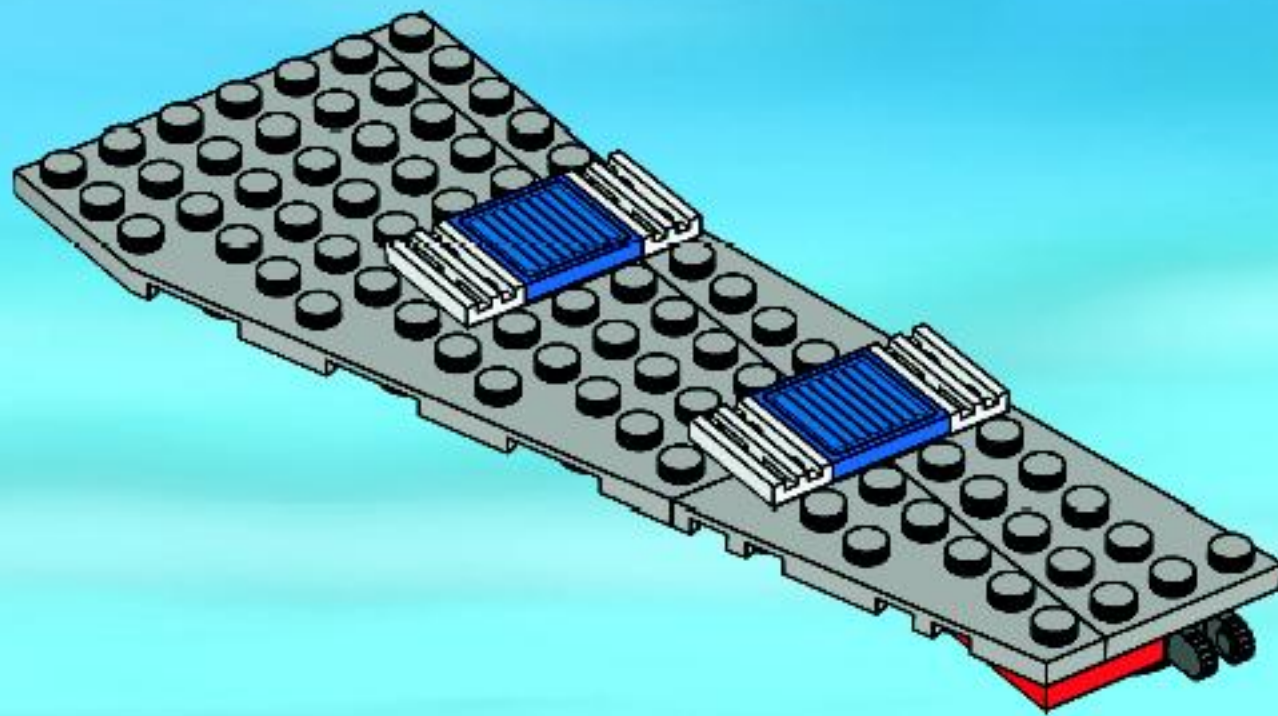

19

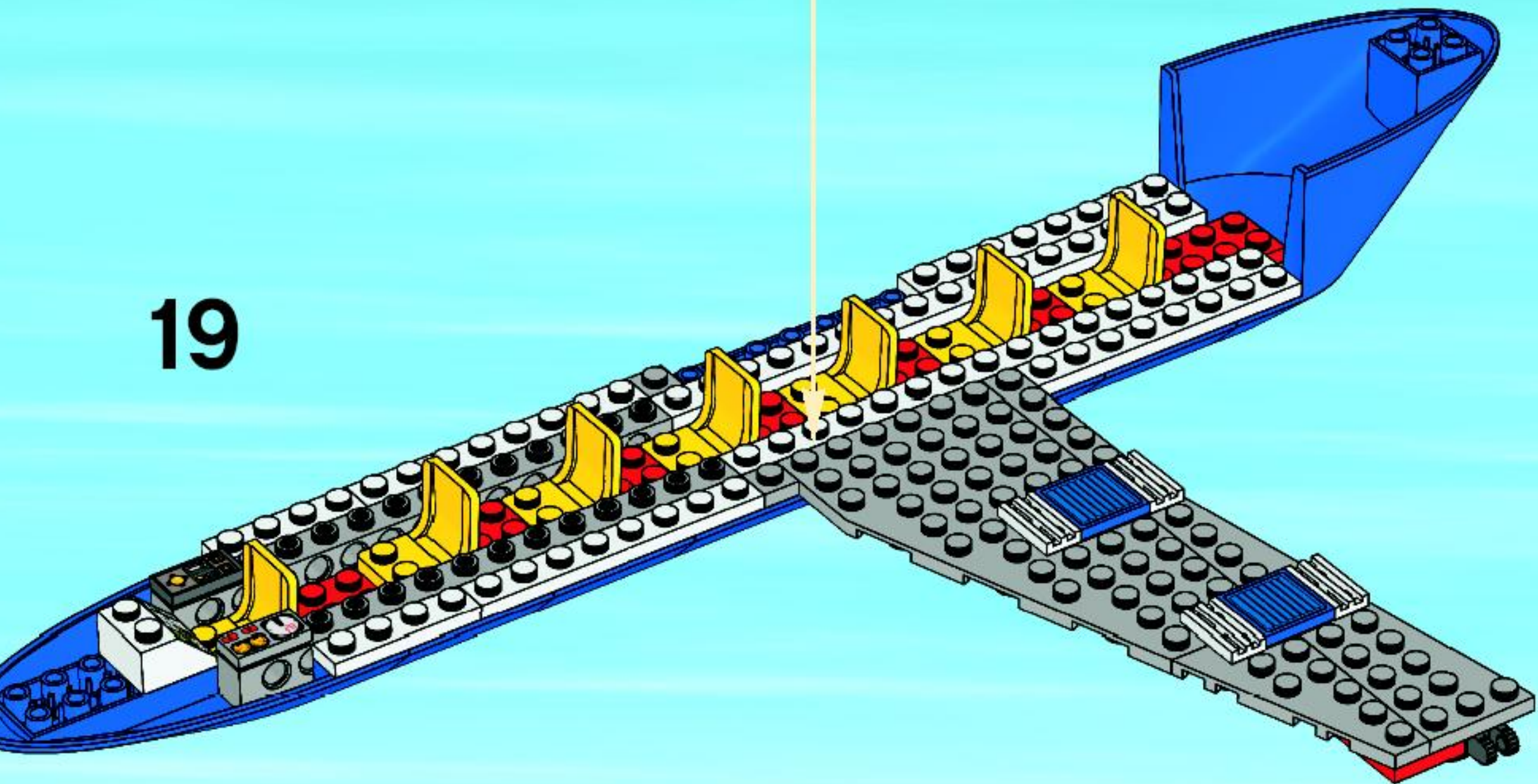

20

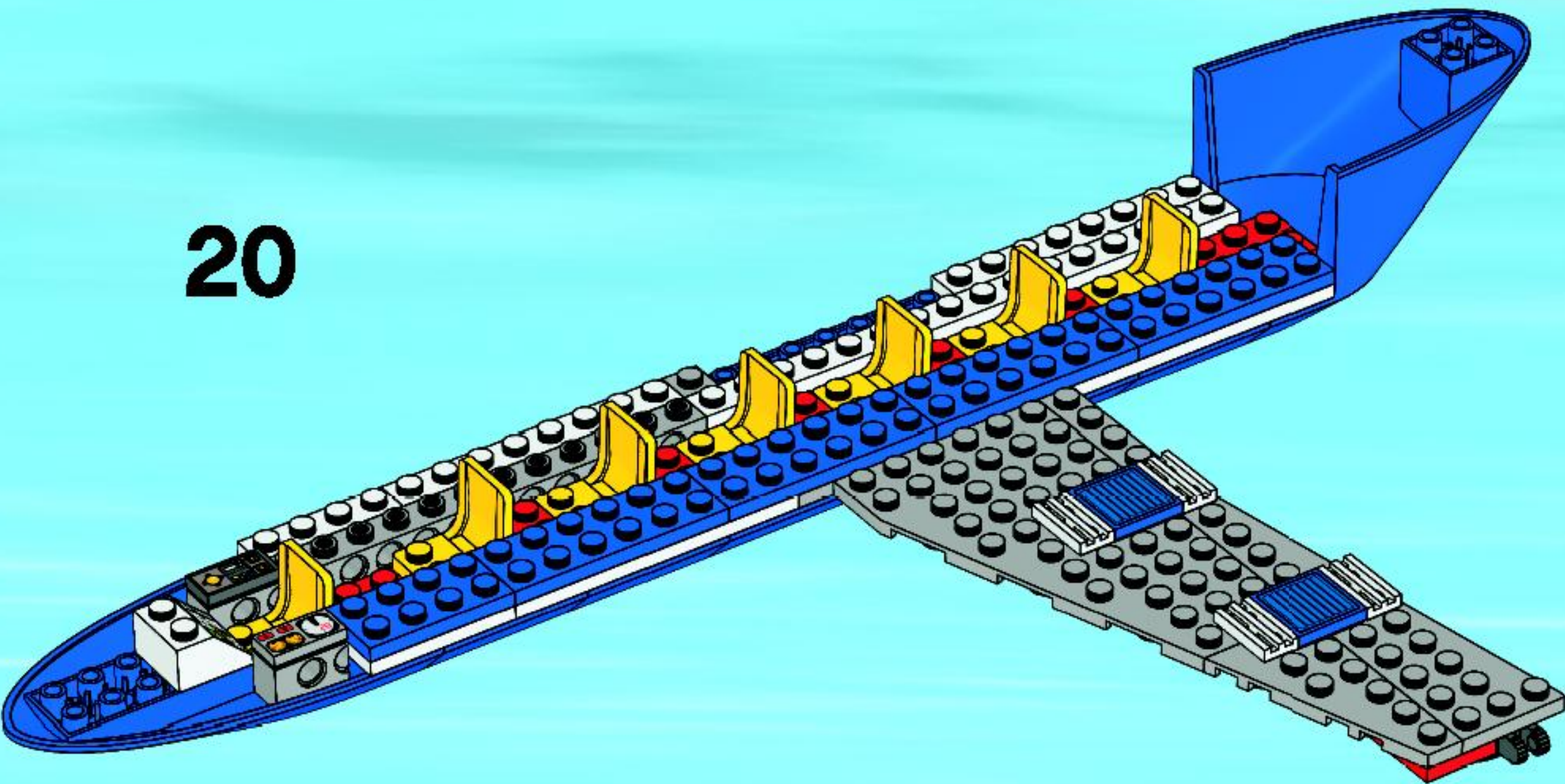

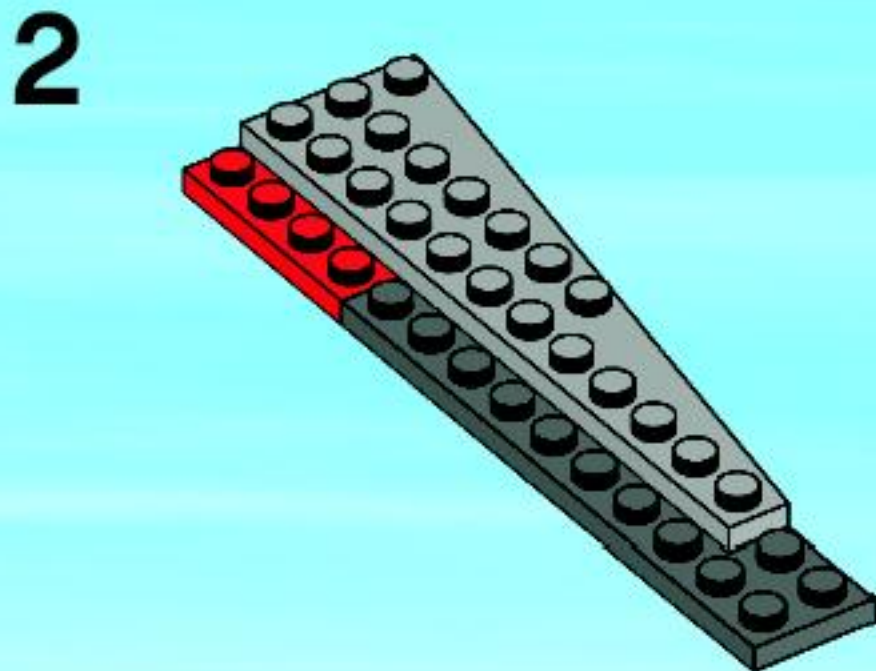
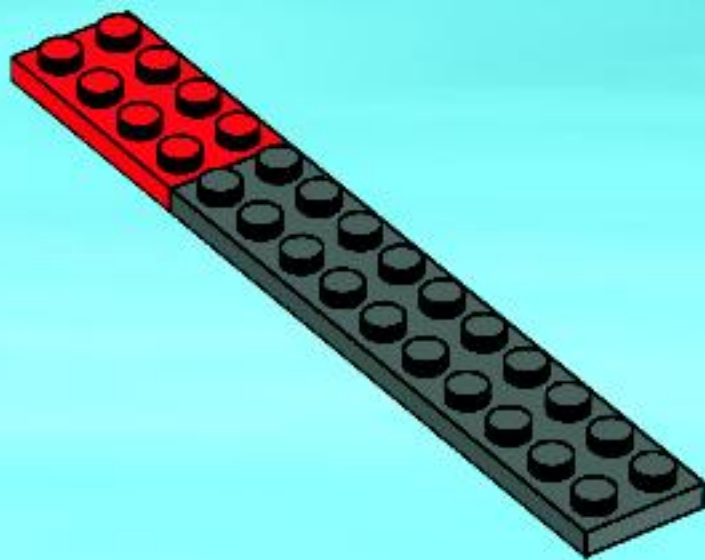
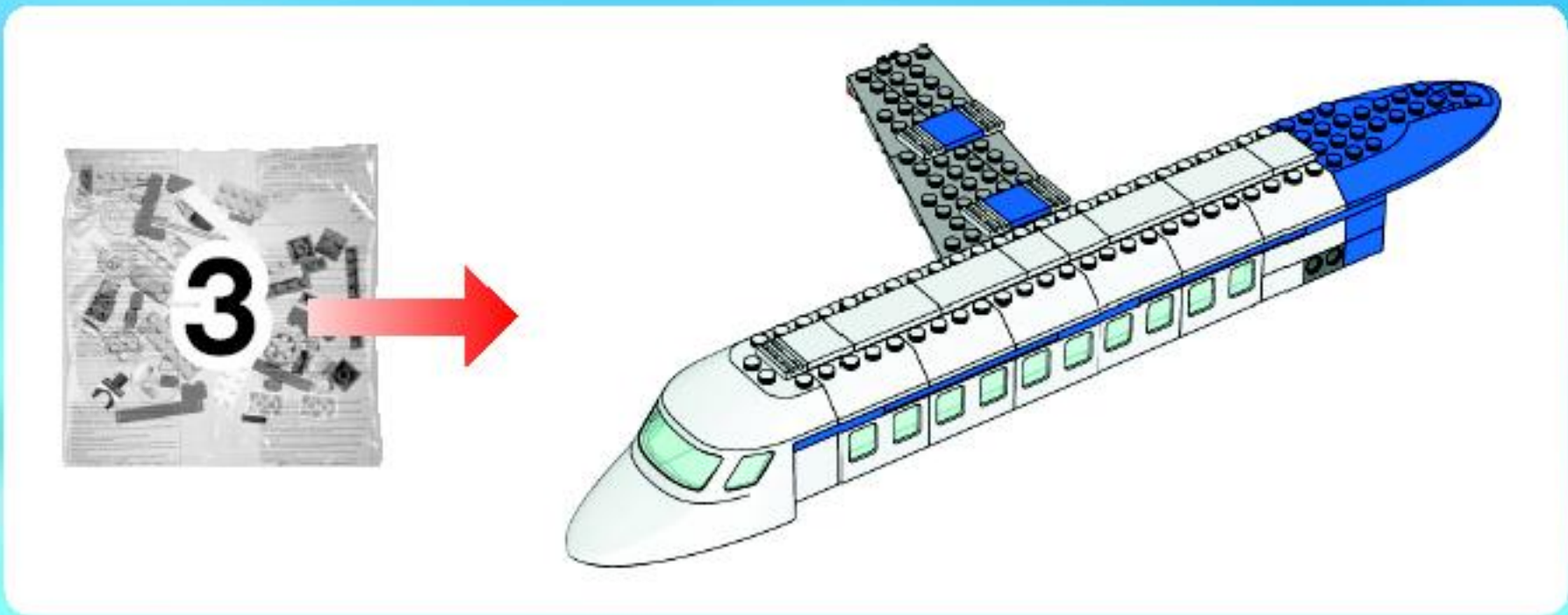

3

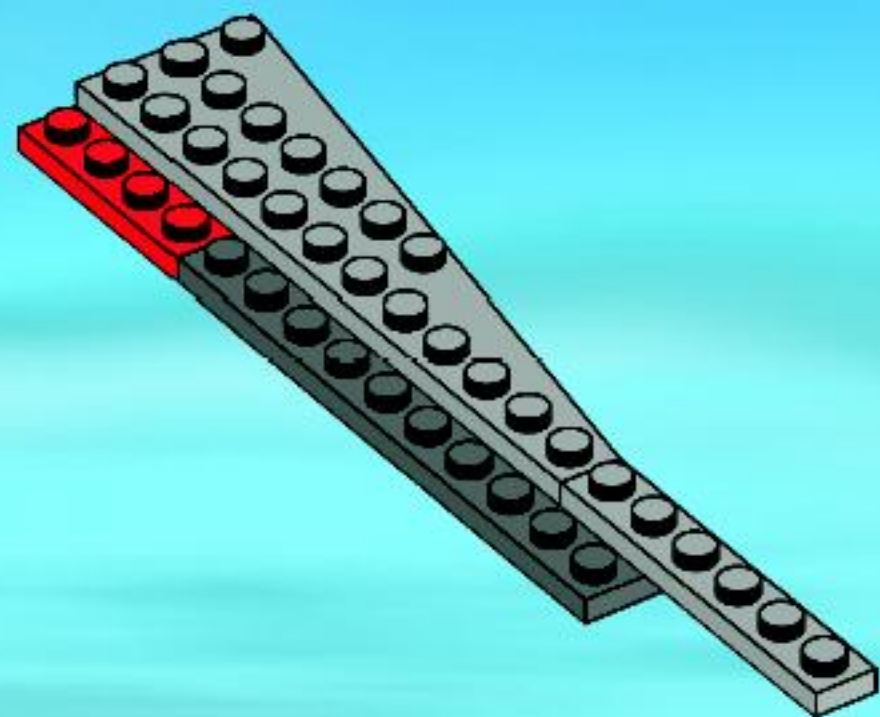

4

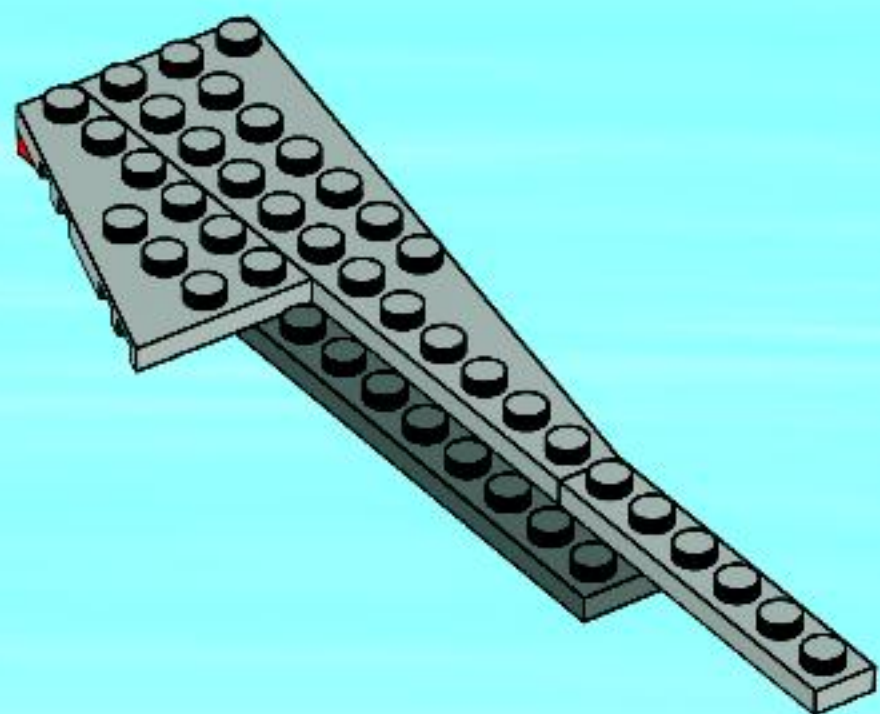

5

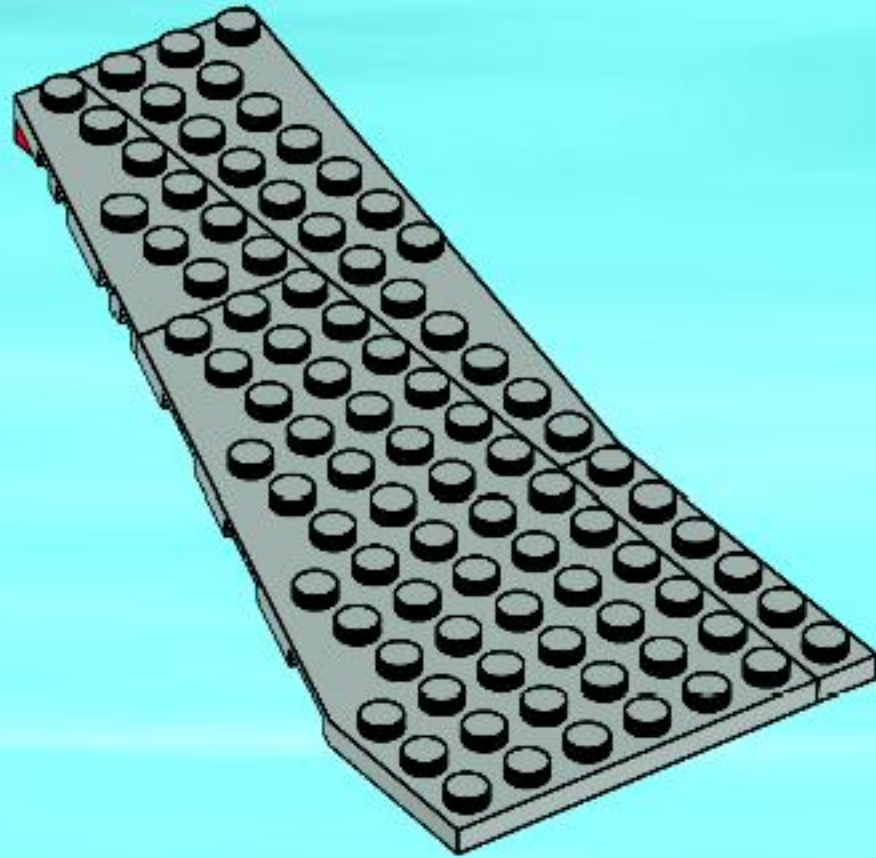

6

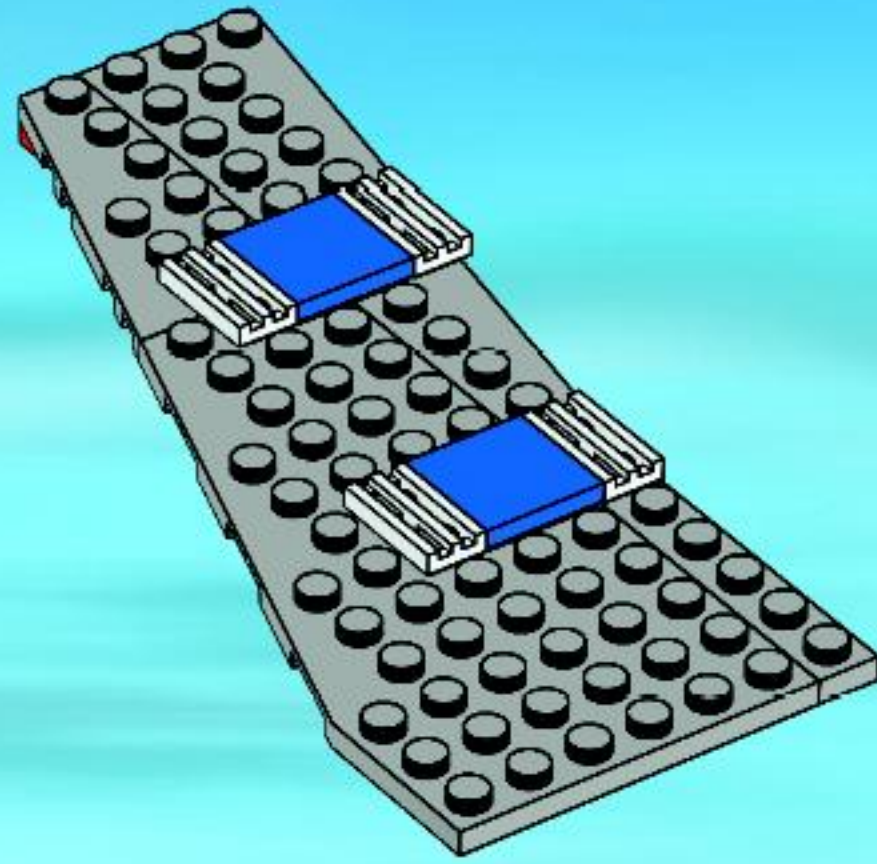

7

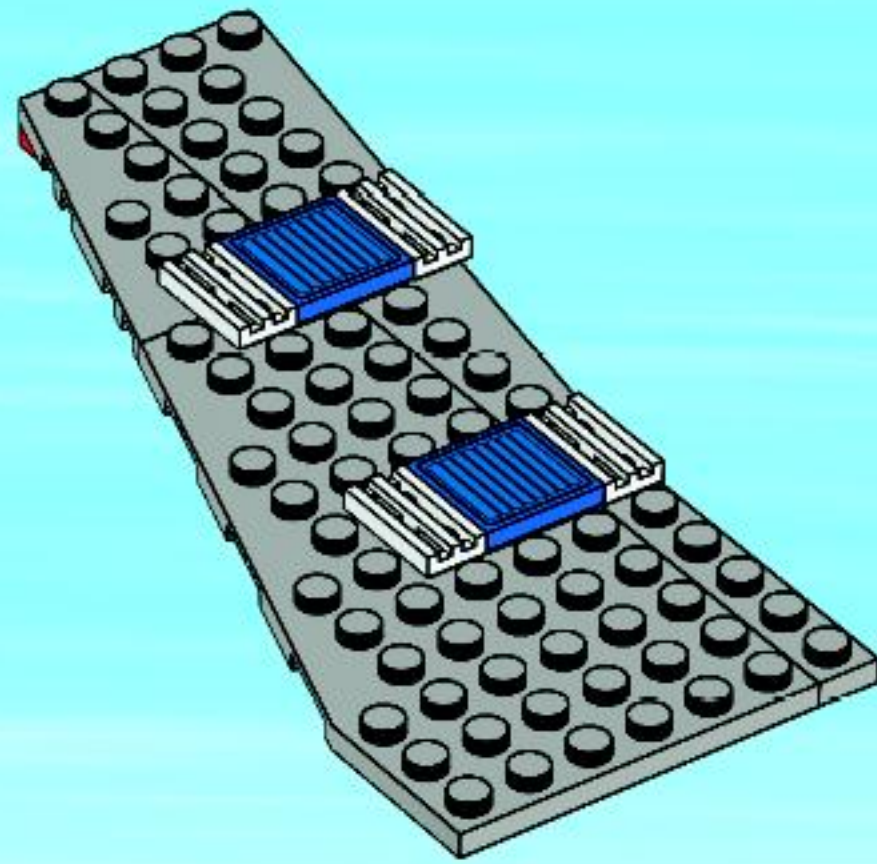

8

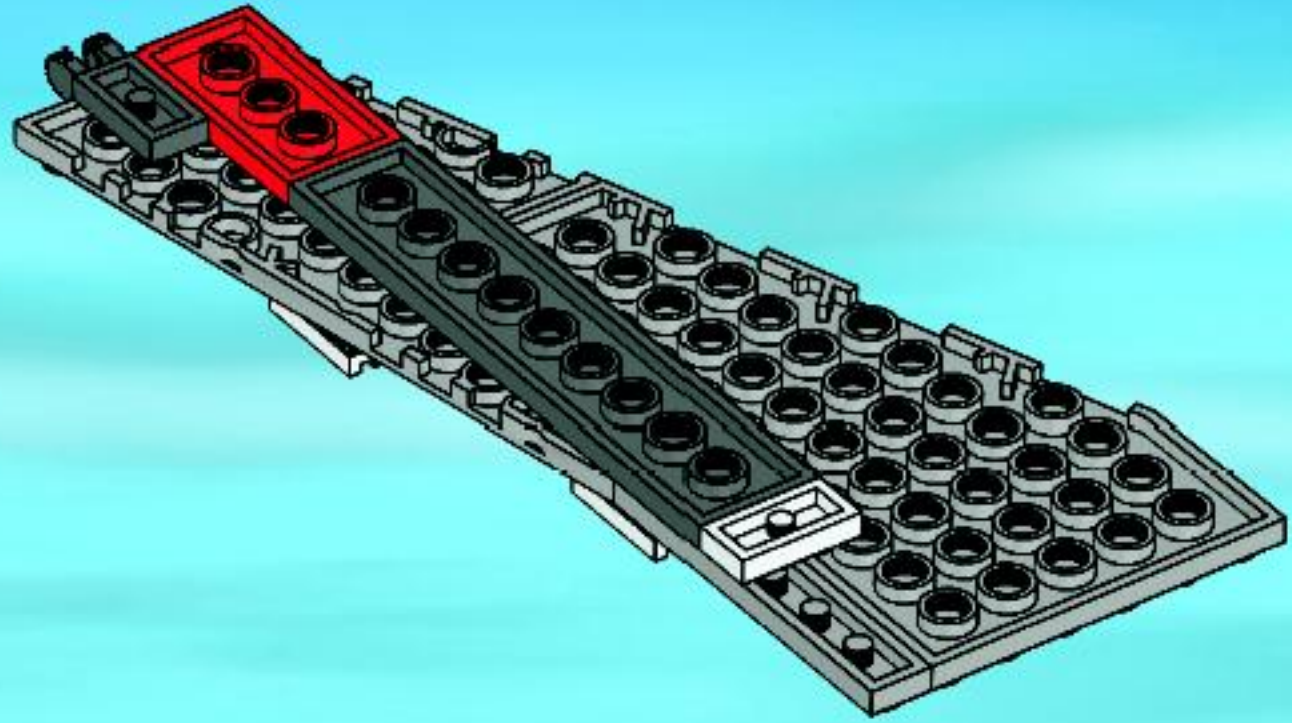

9

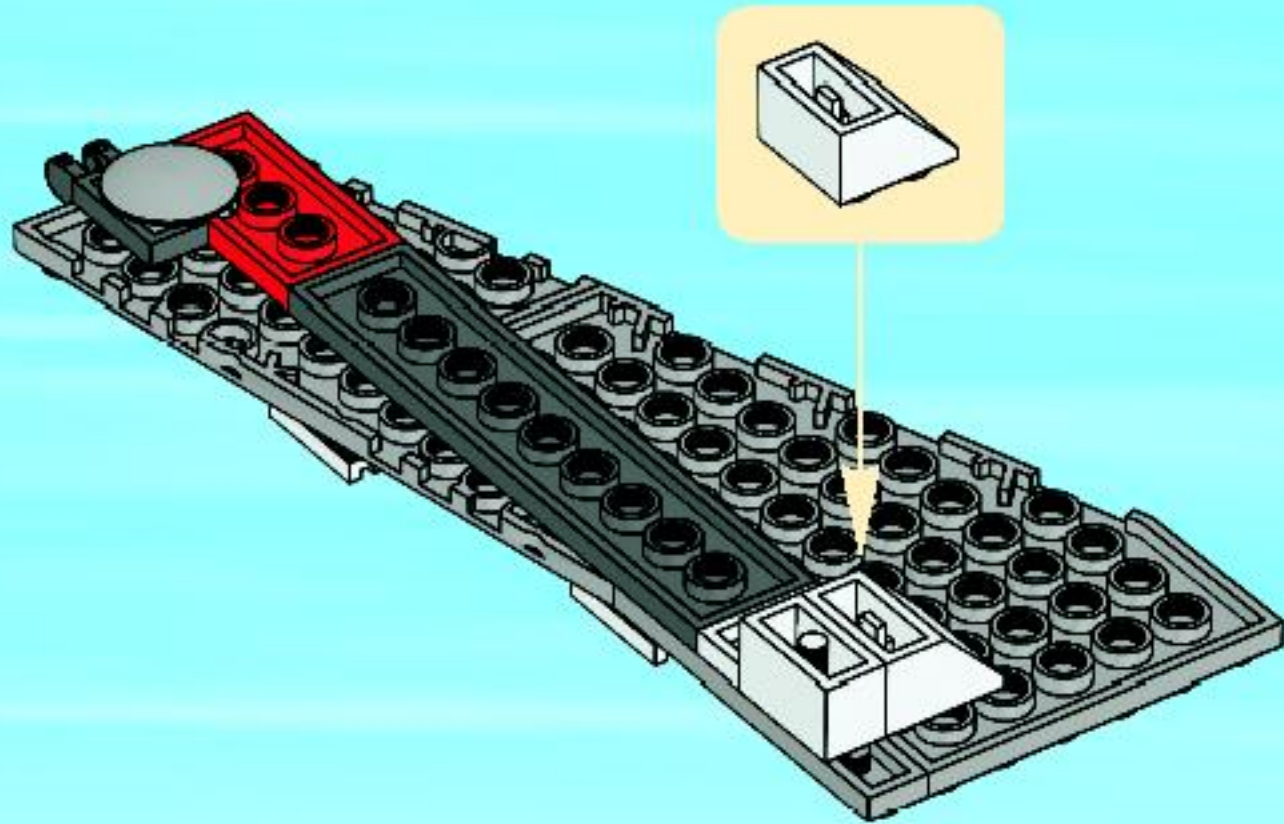

10

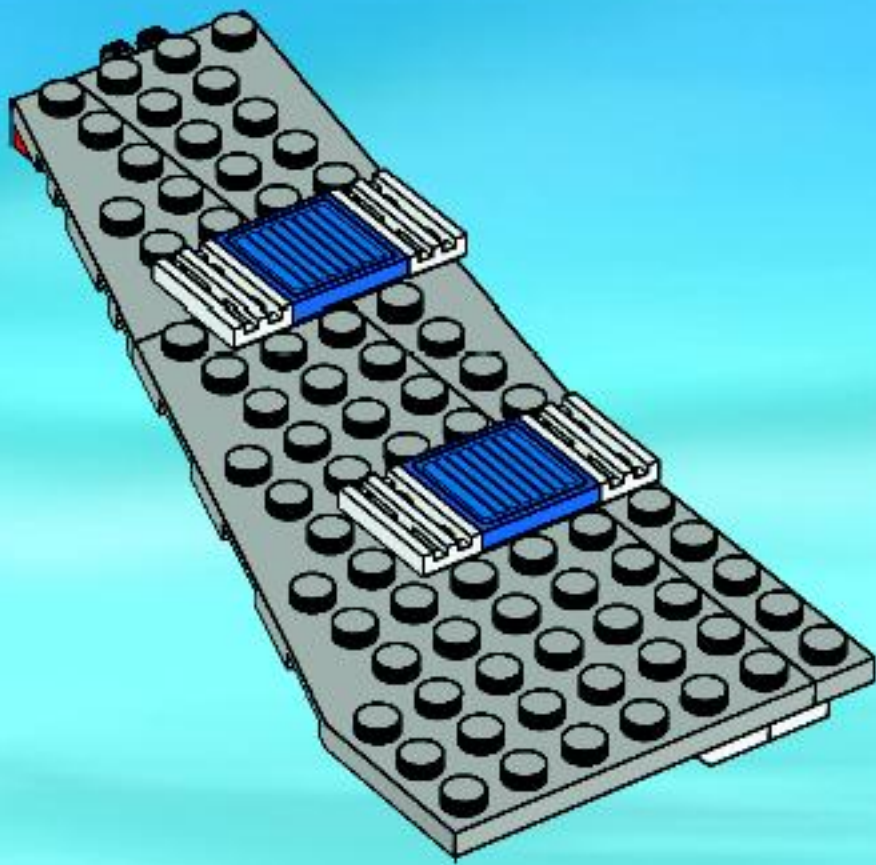

21

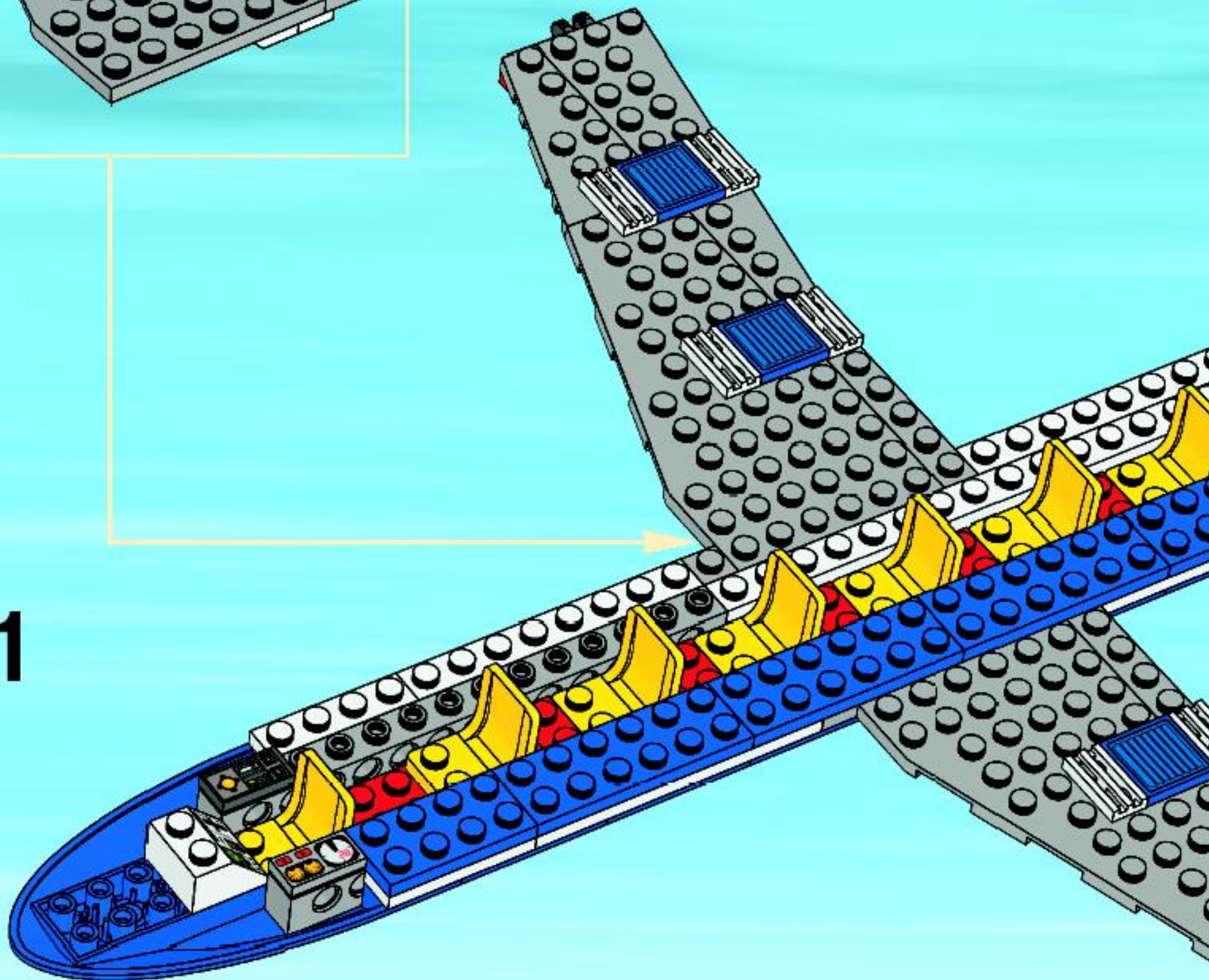

22

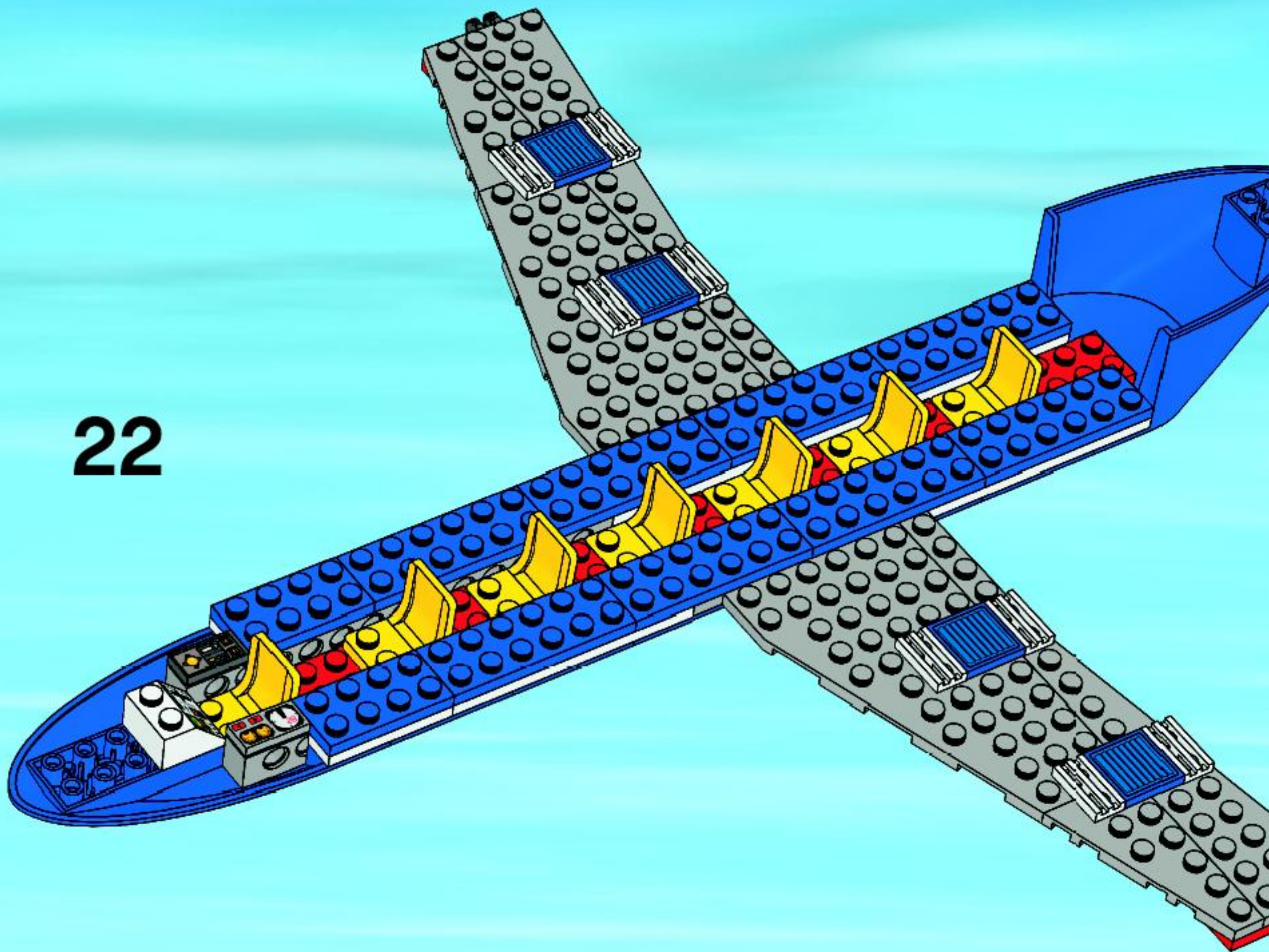

23

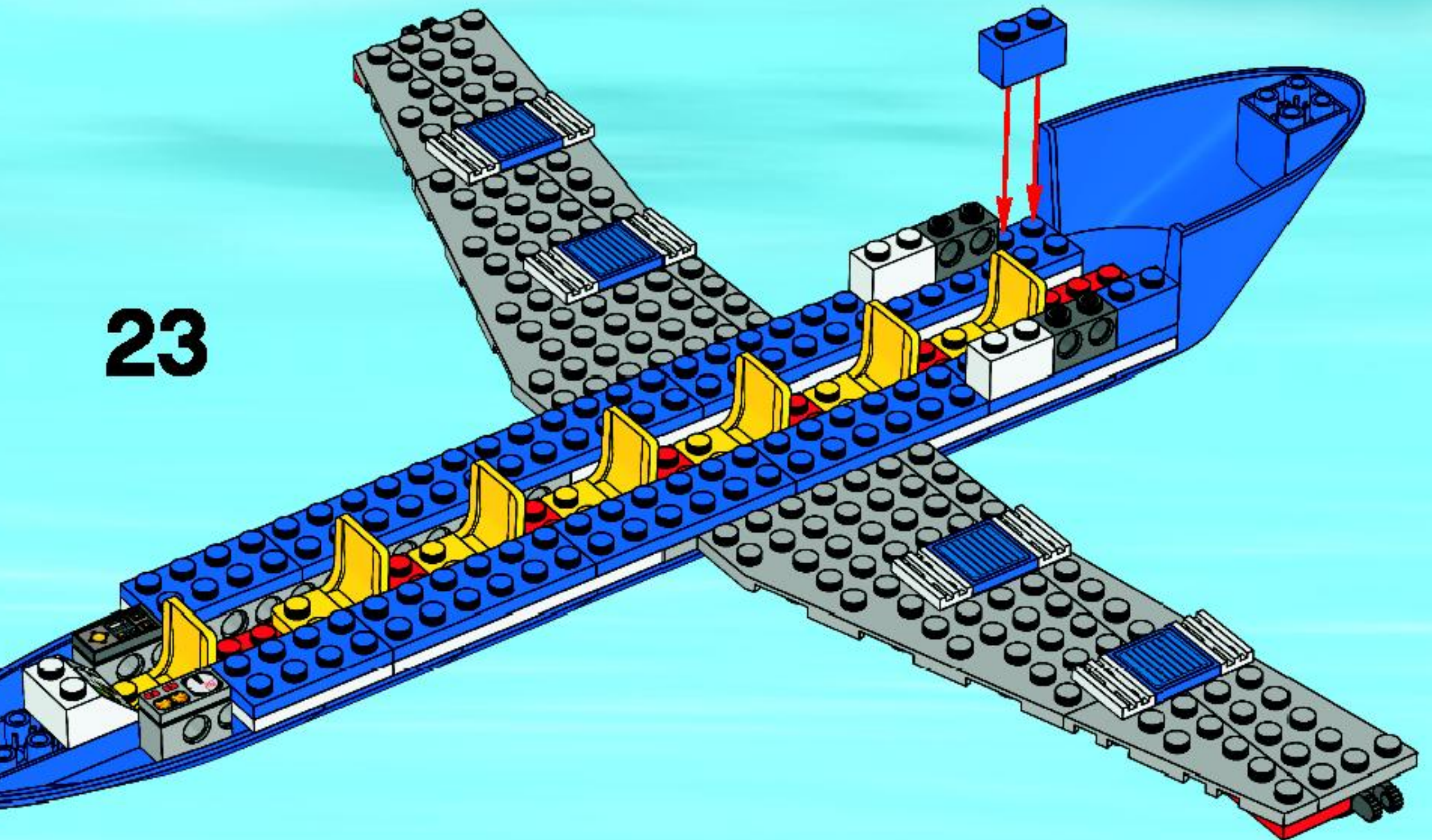

24

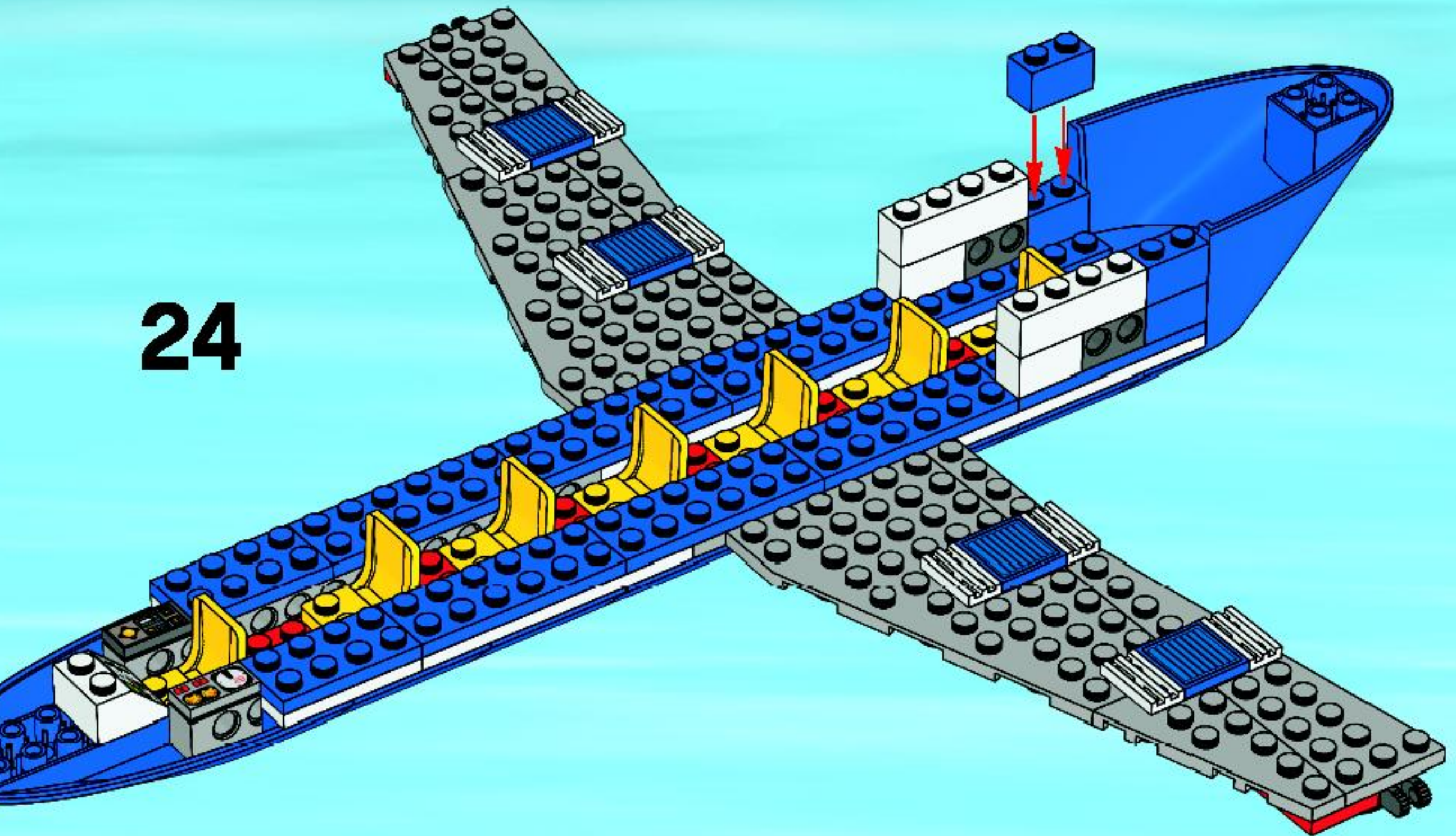

1



2

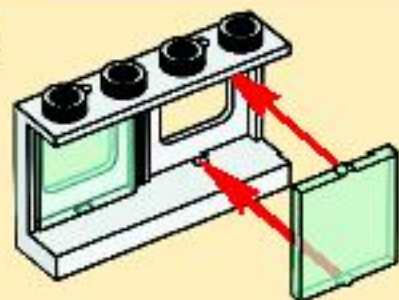

10x

25

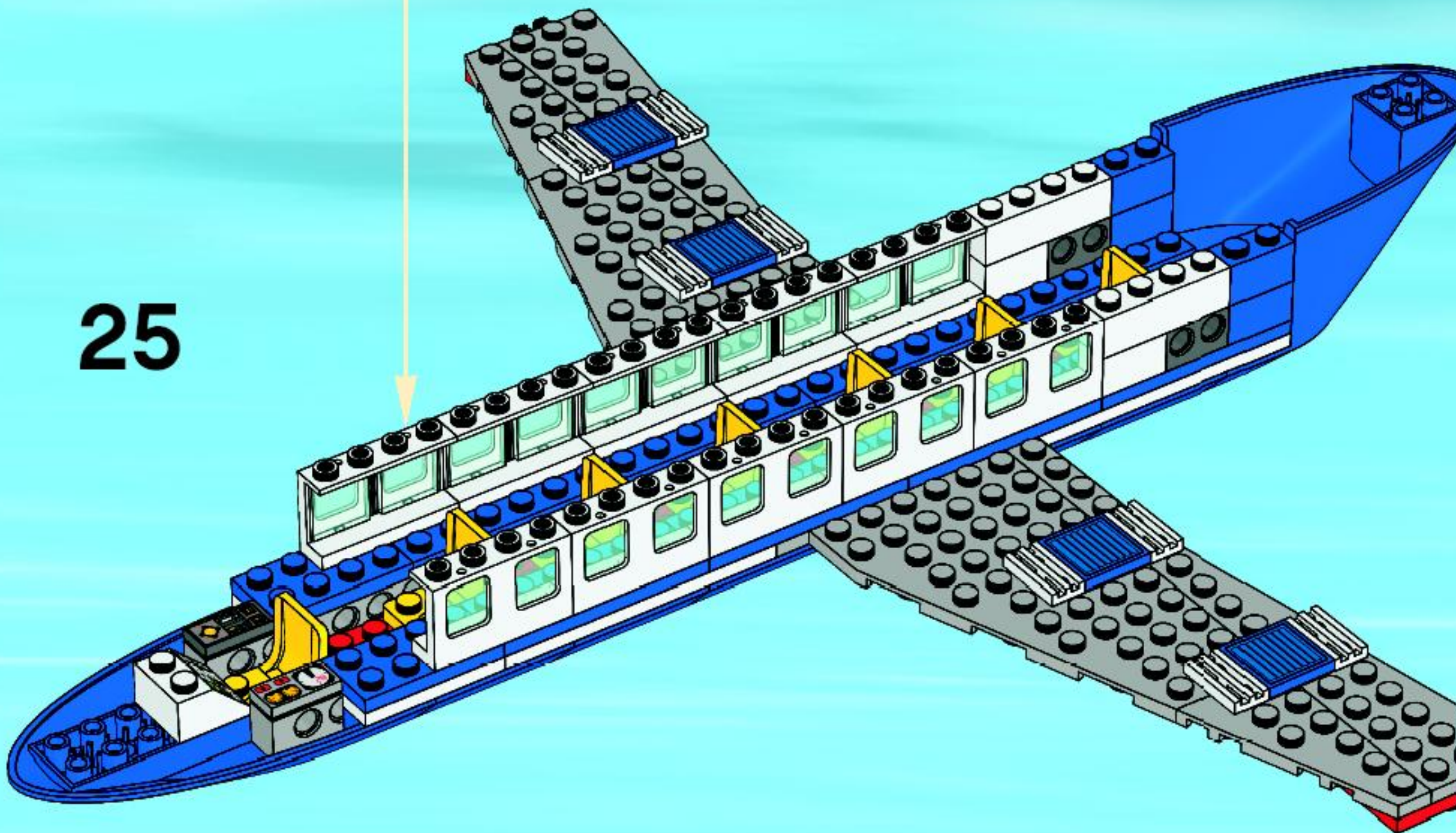

26

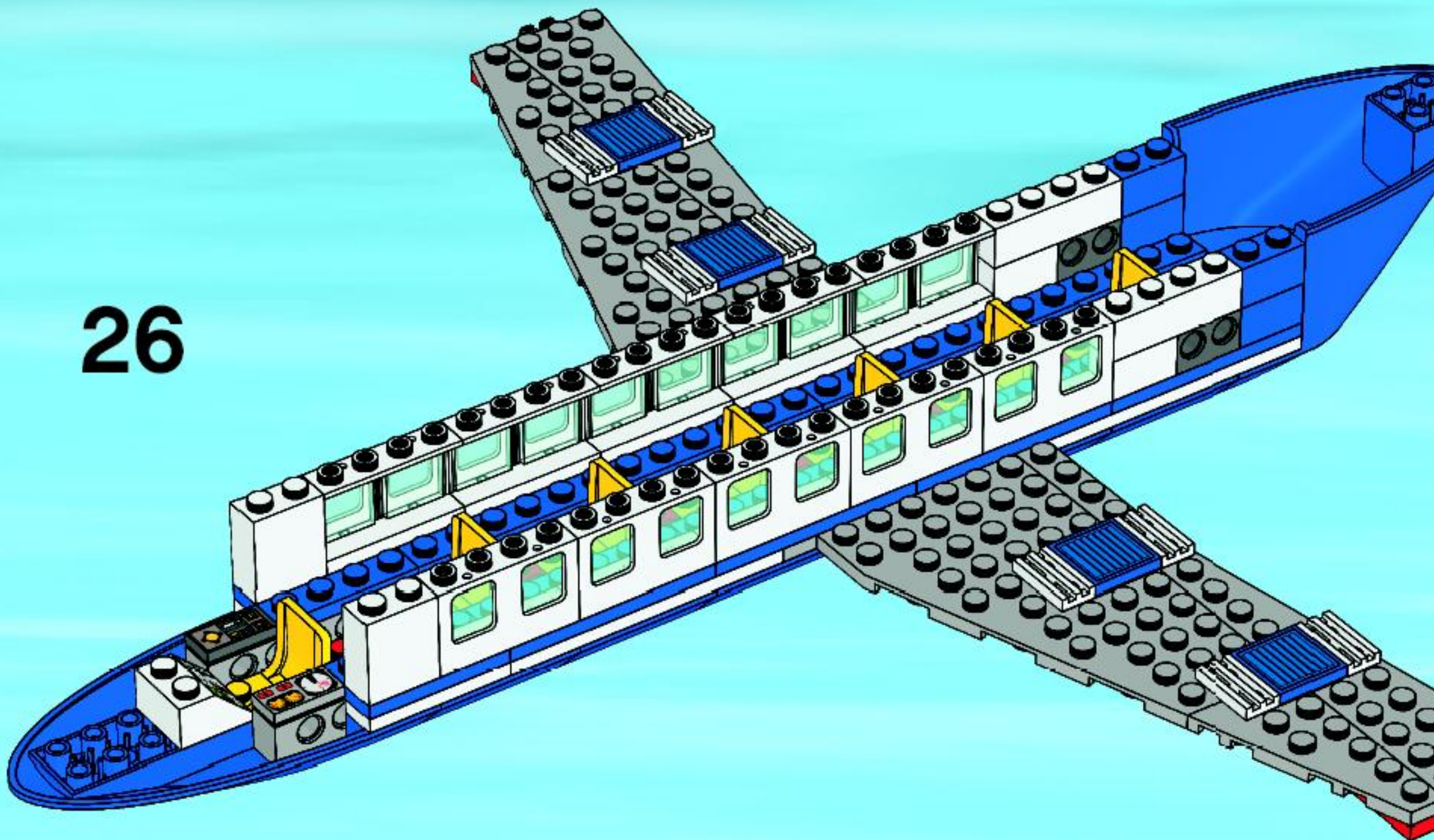

27

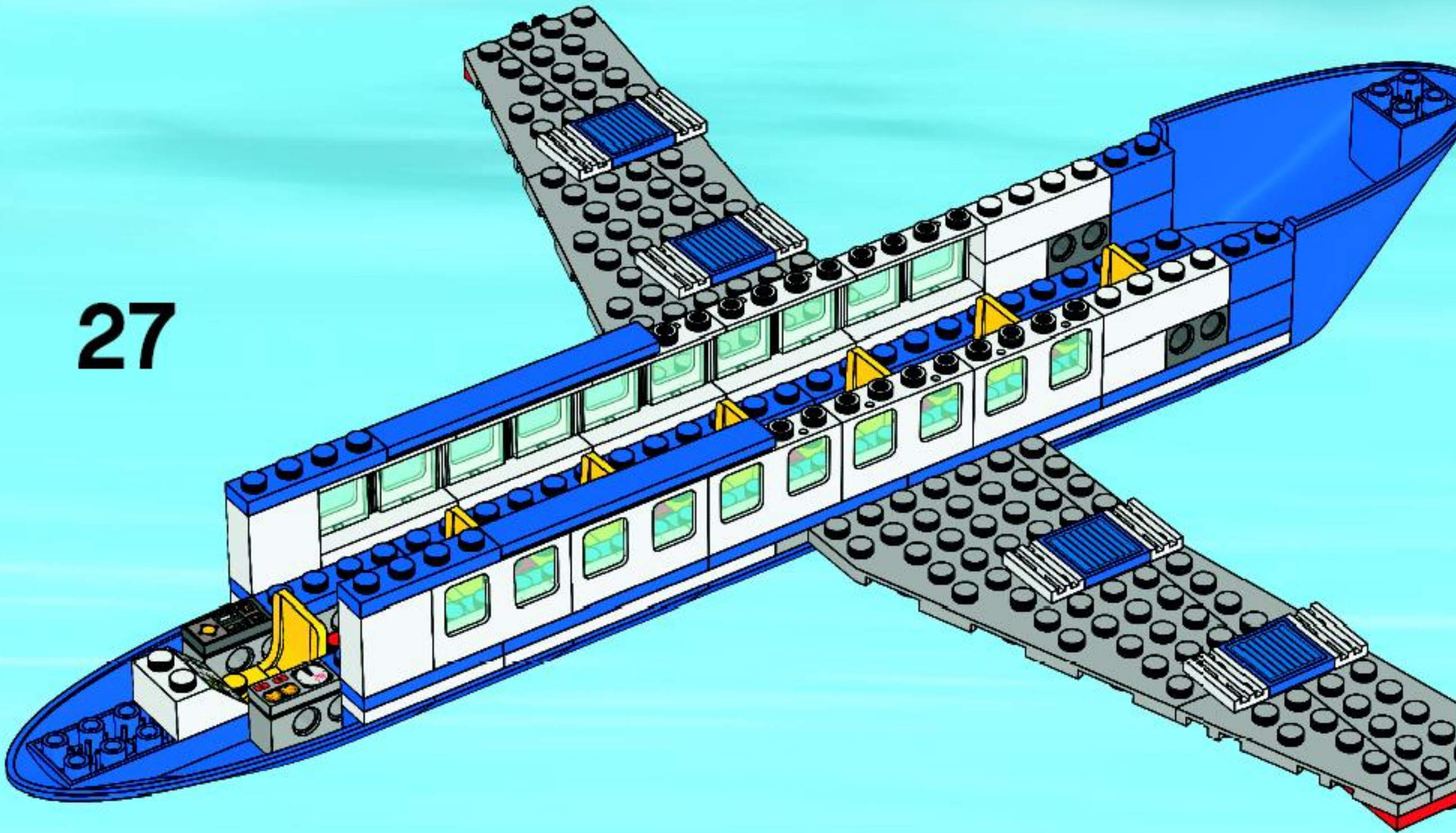

28

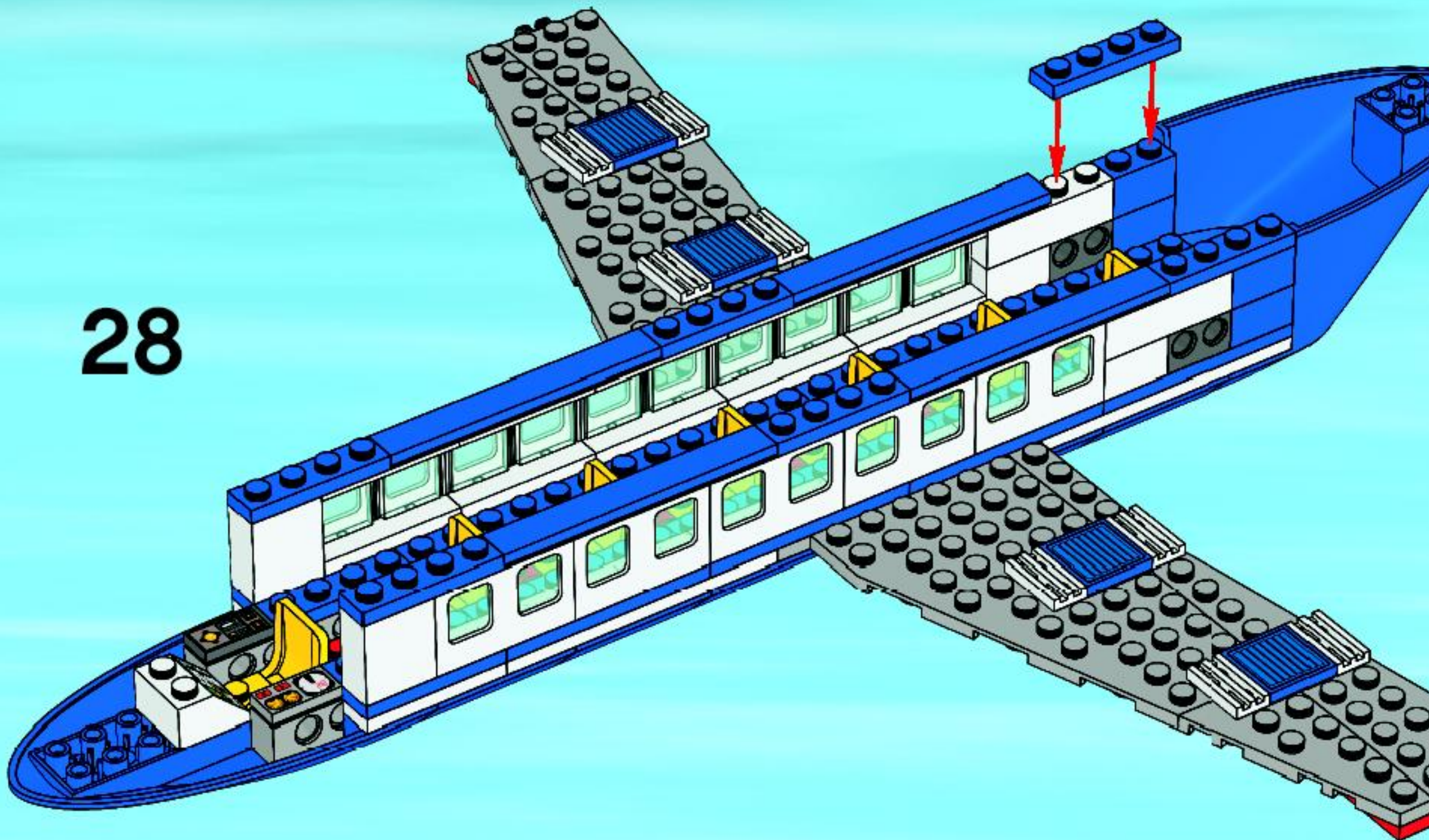

1

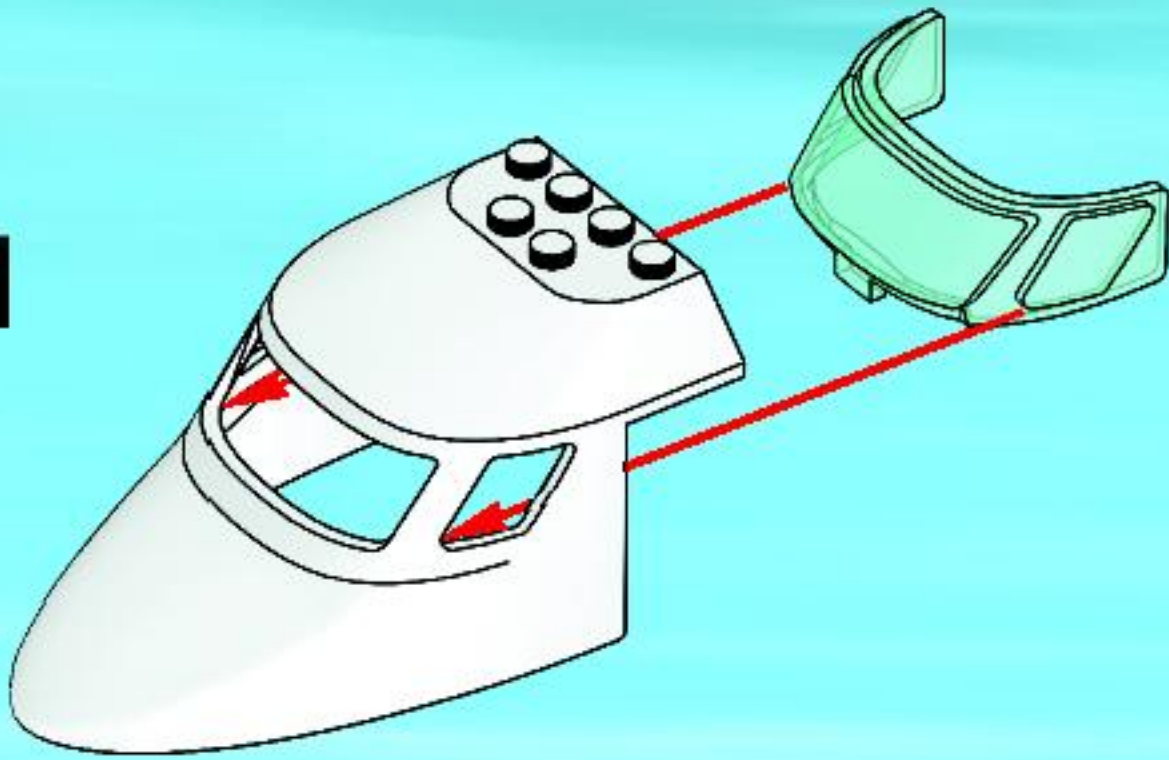

2

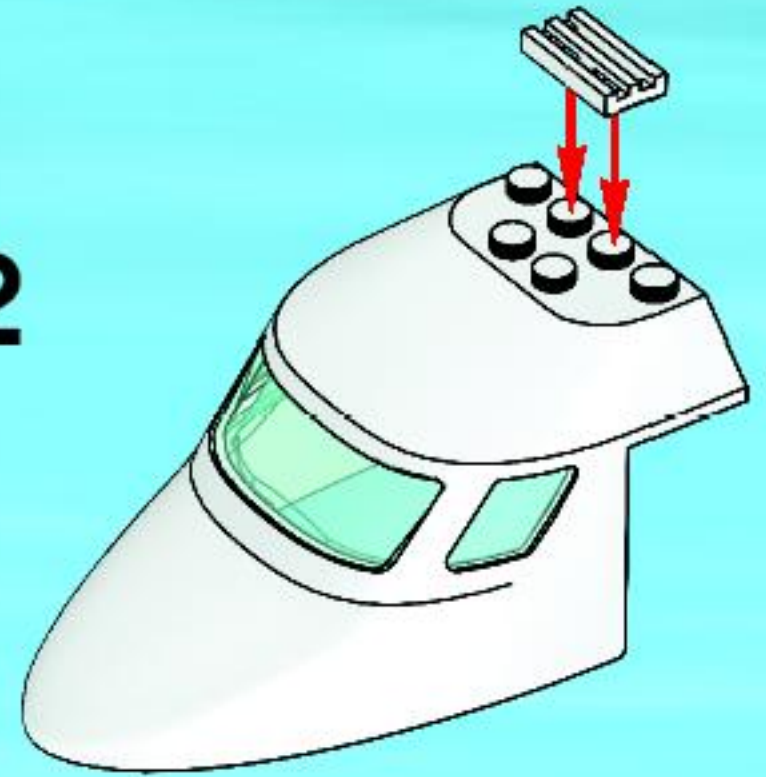

29

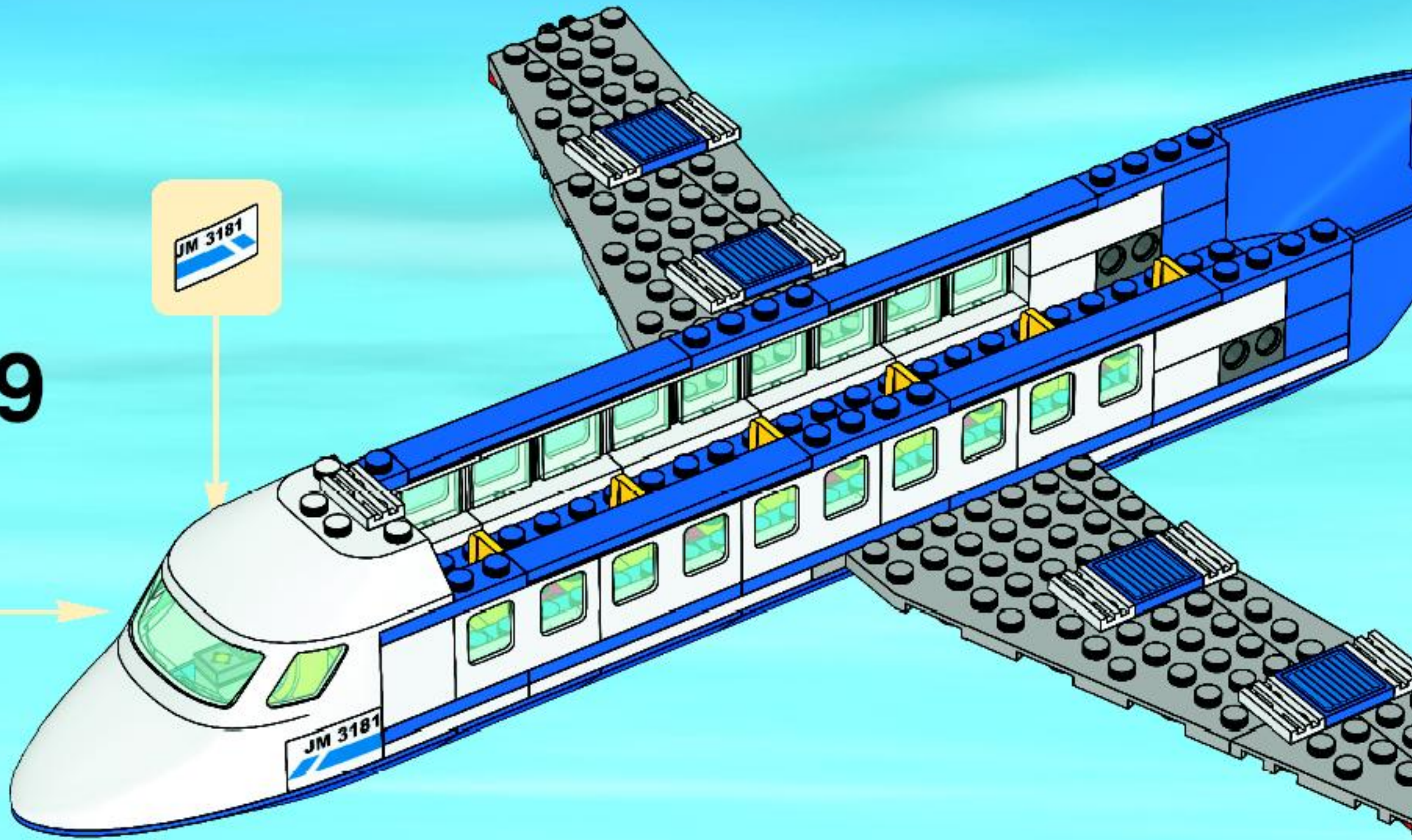

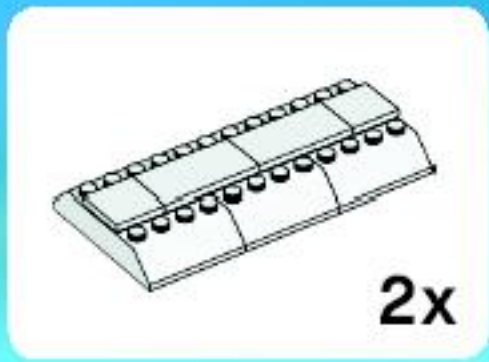

1

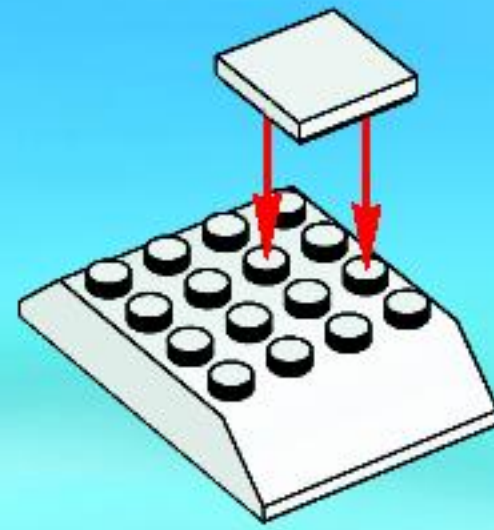

2

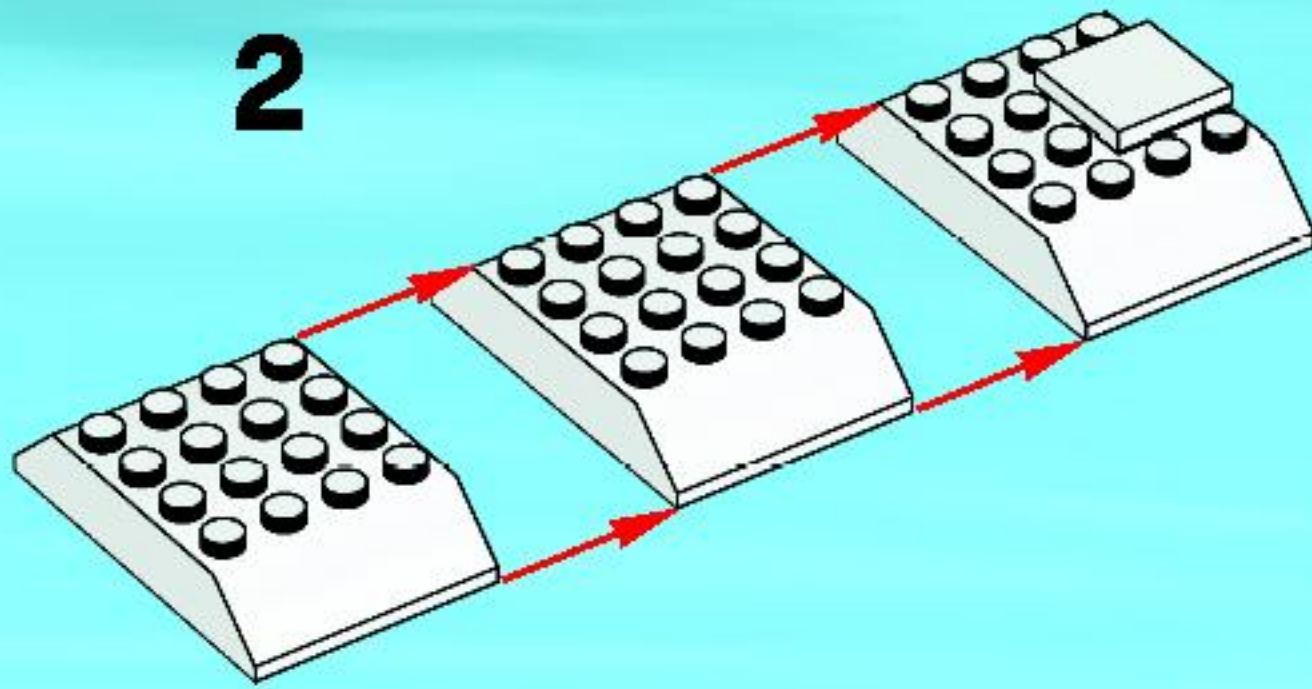

3

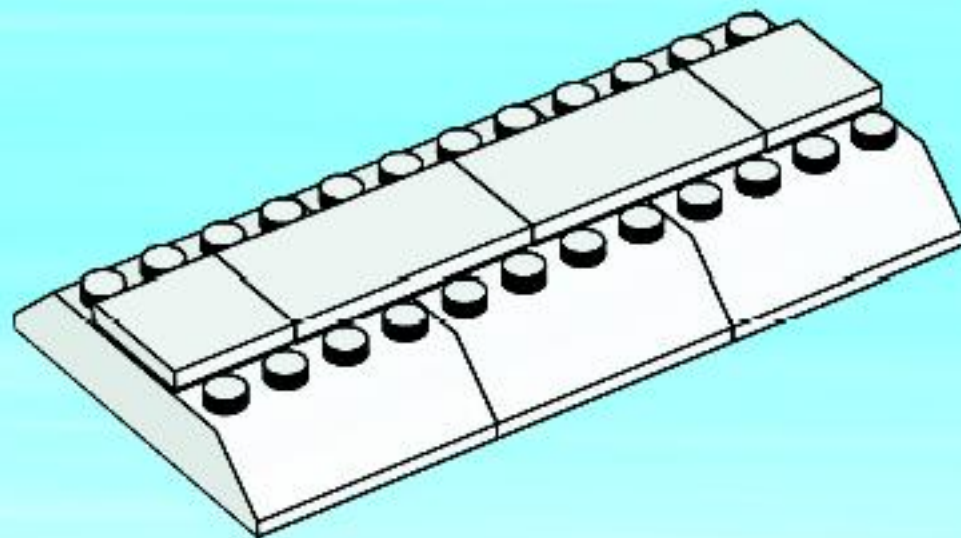

4

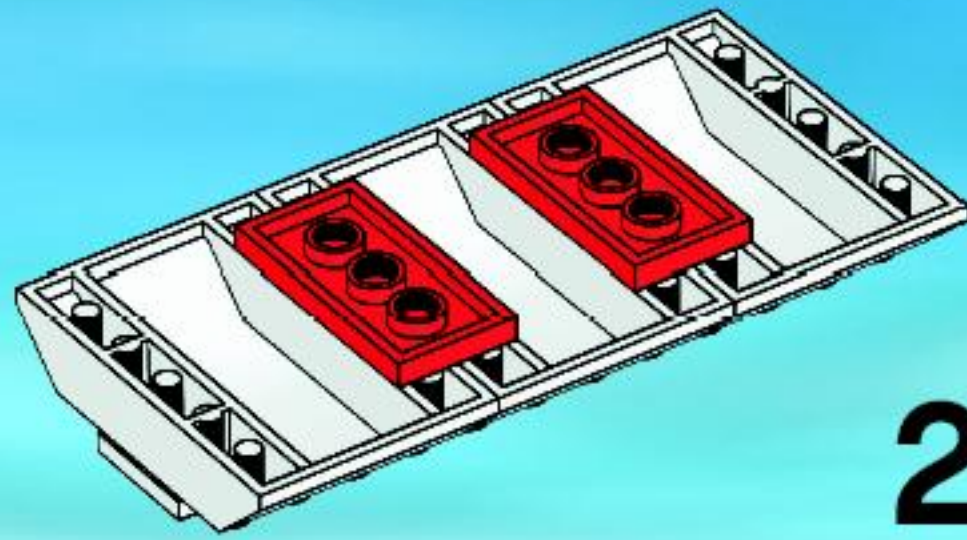

2x

30

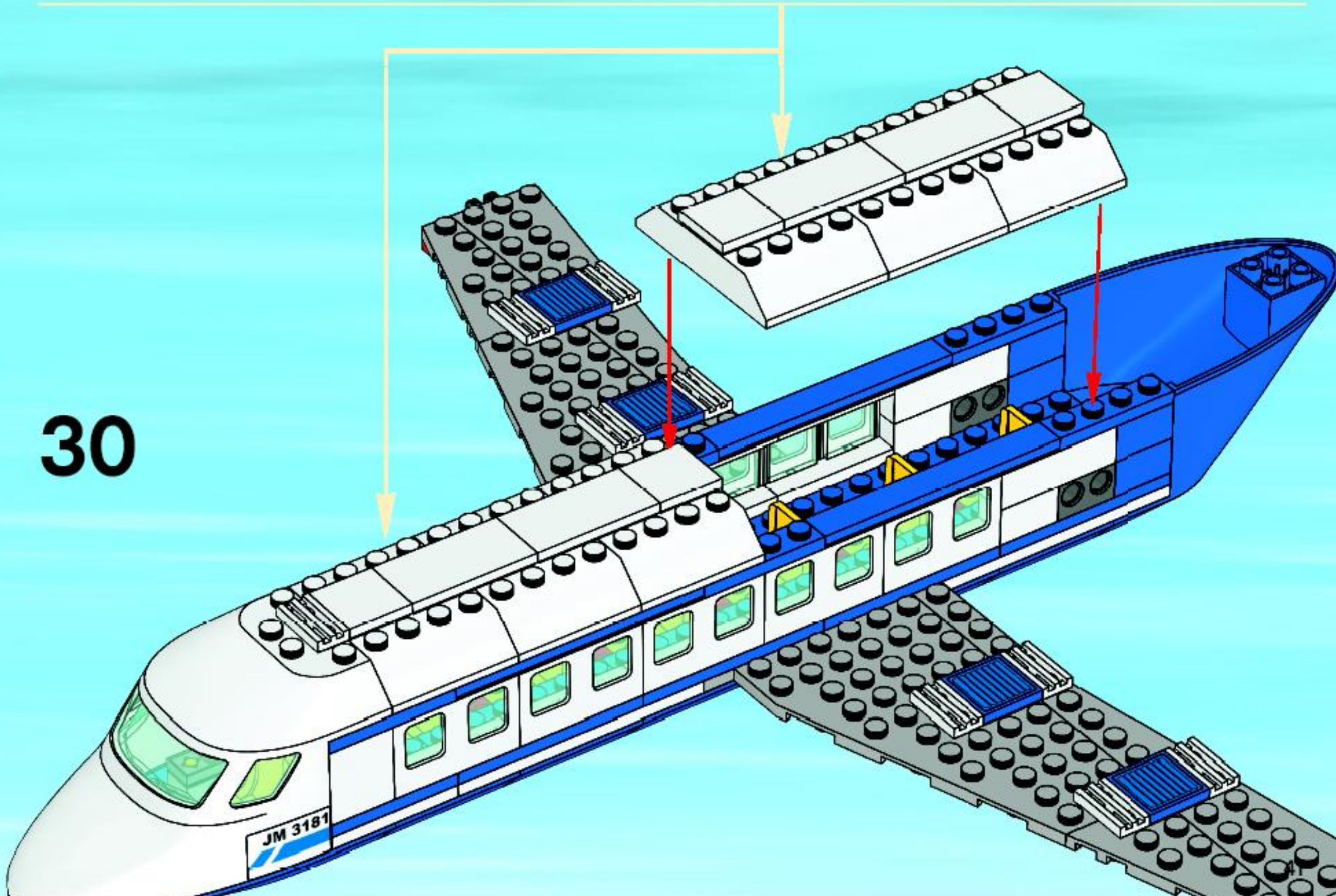

31

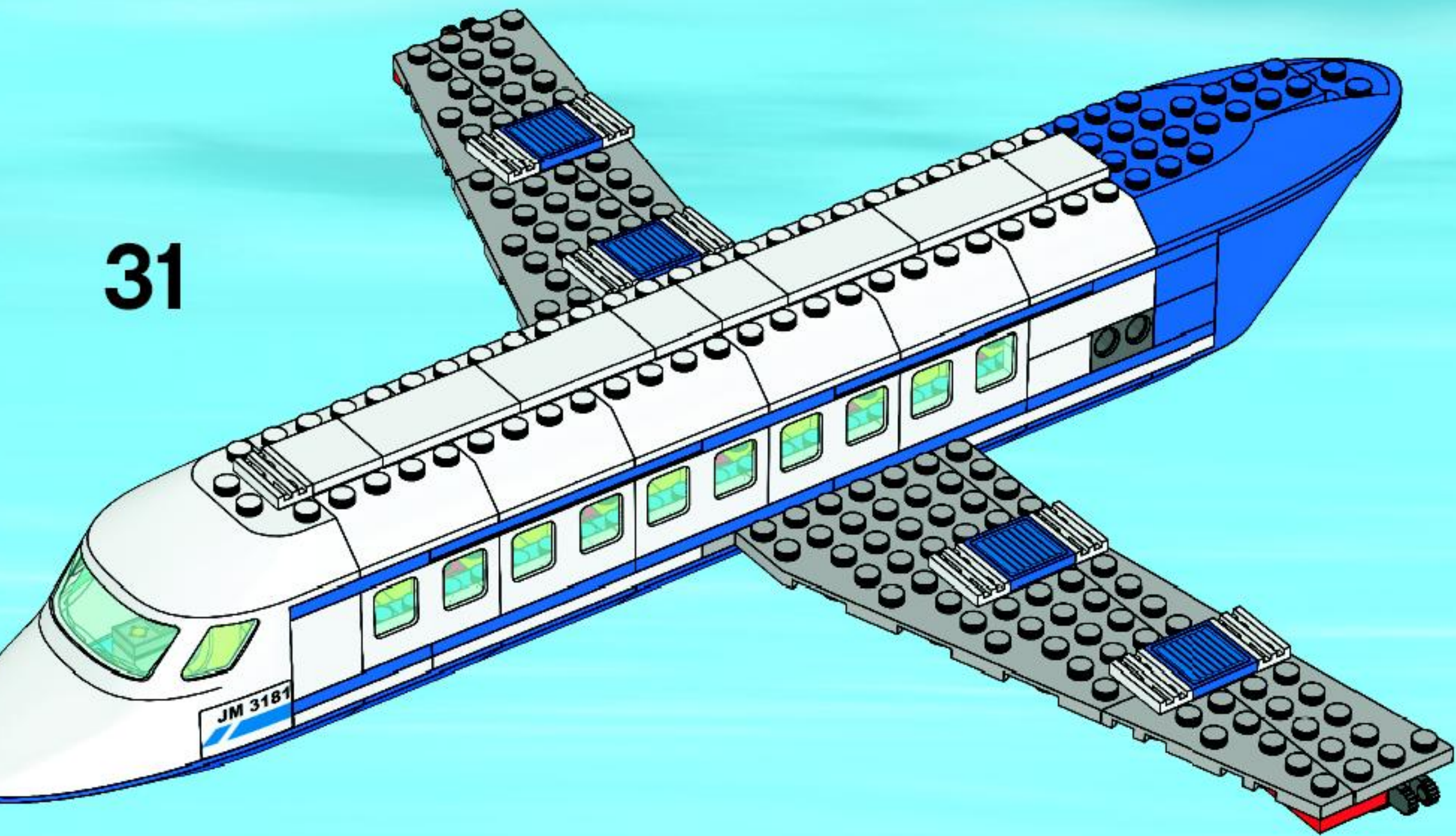

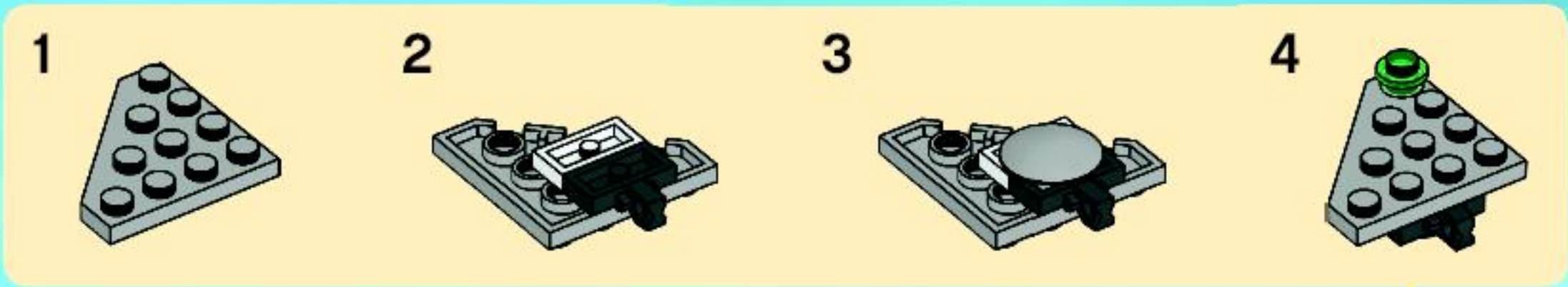
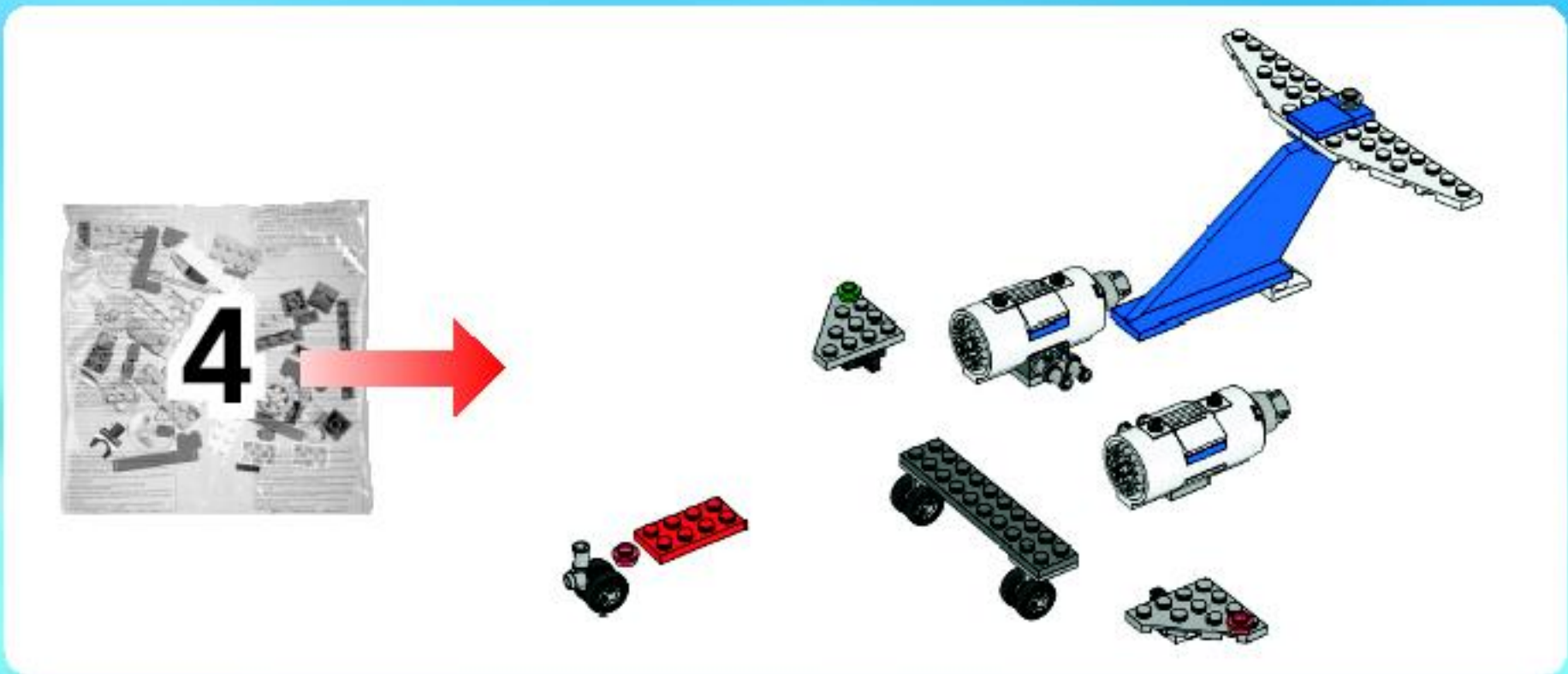

32

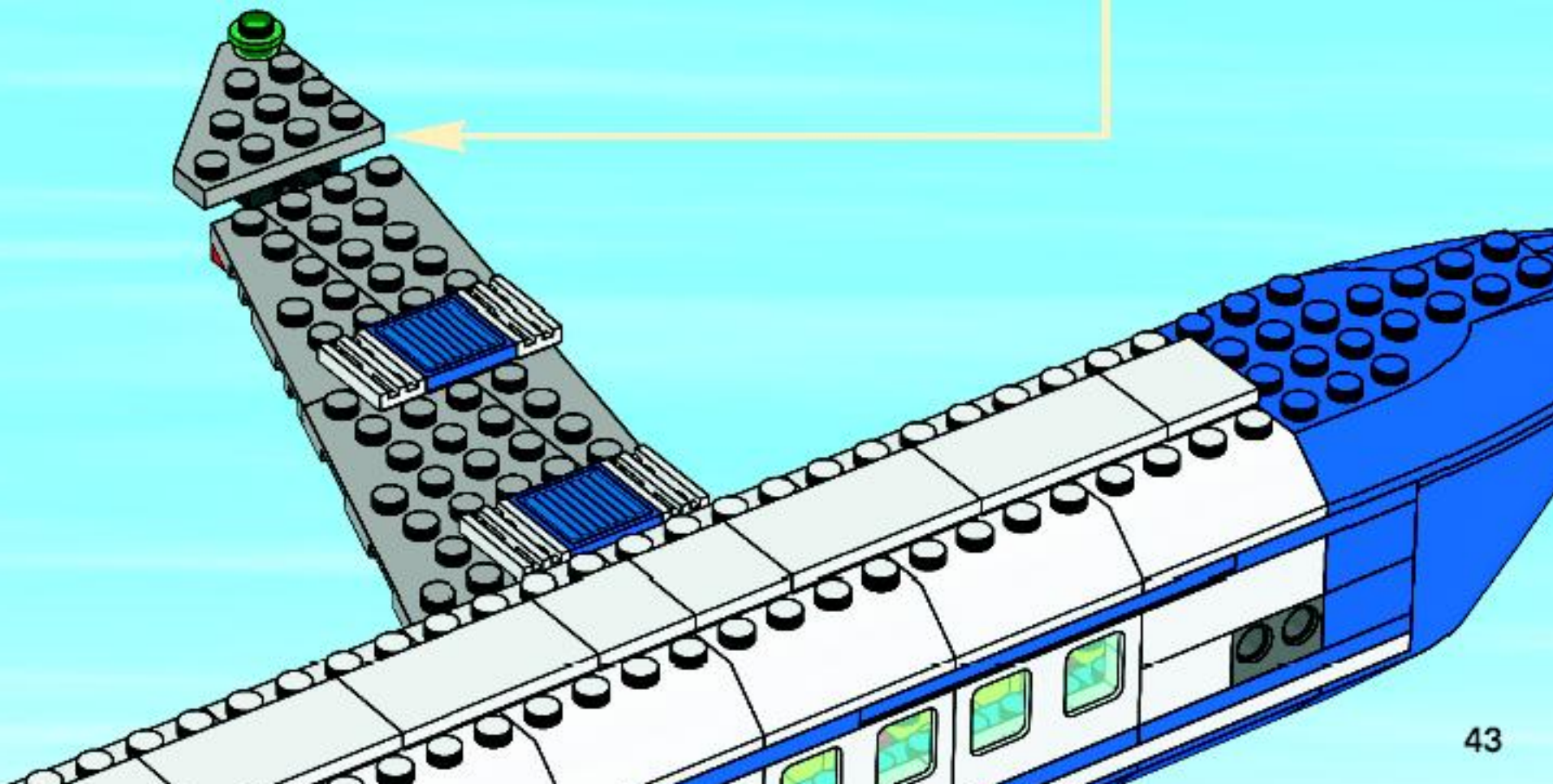

33

1

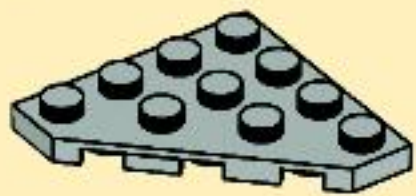

2



3



4

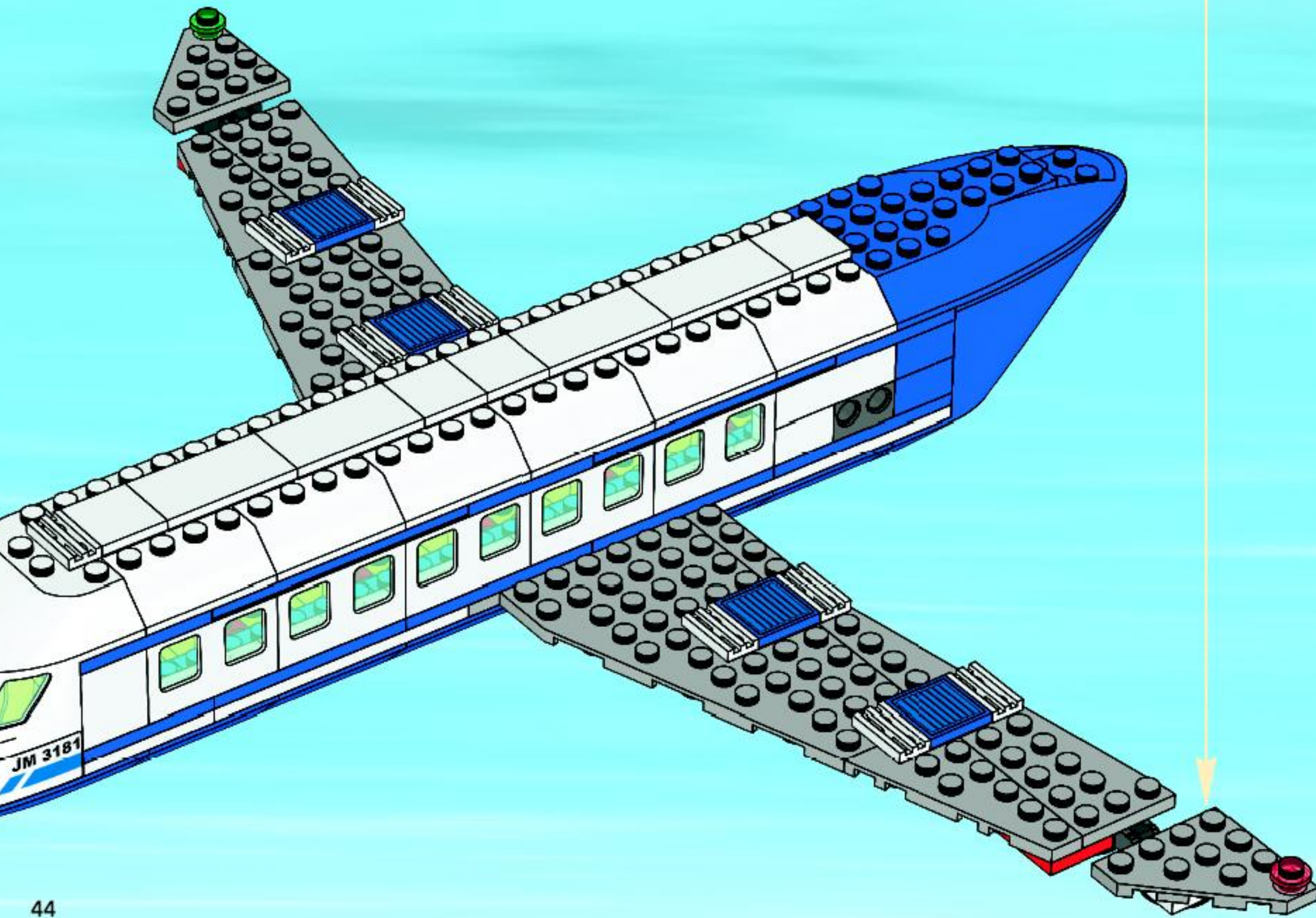

34

1



2



3



2x

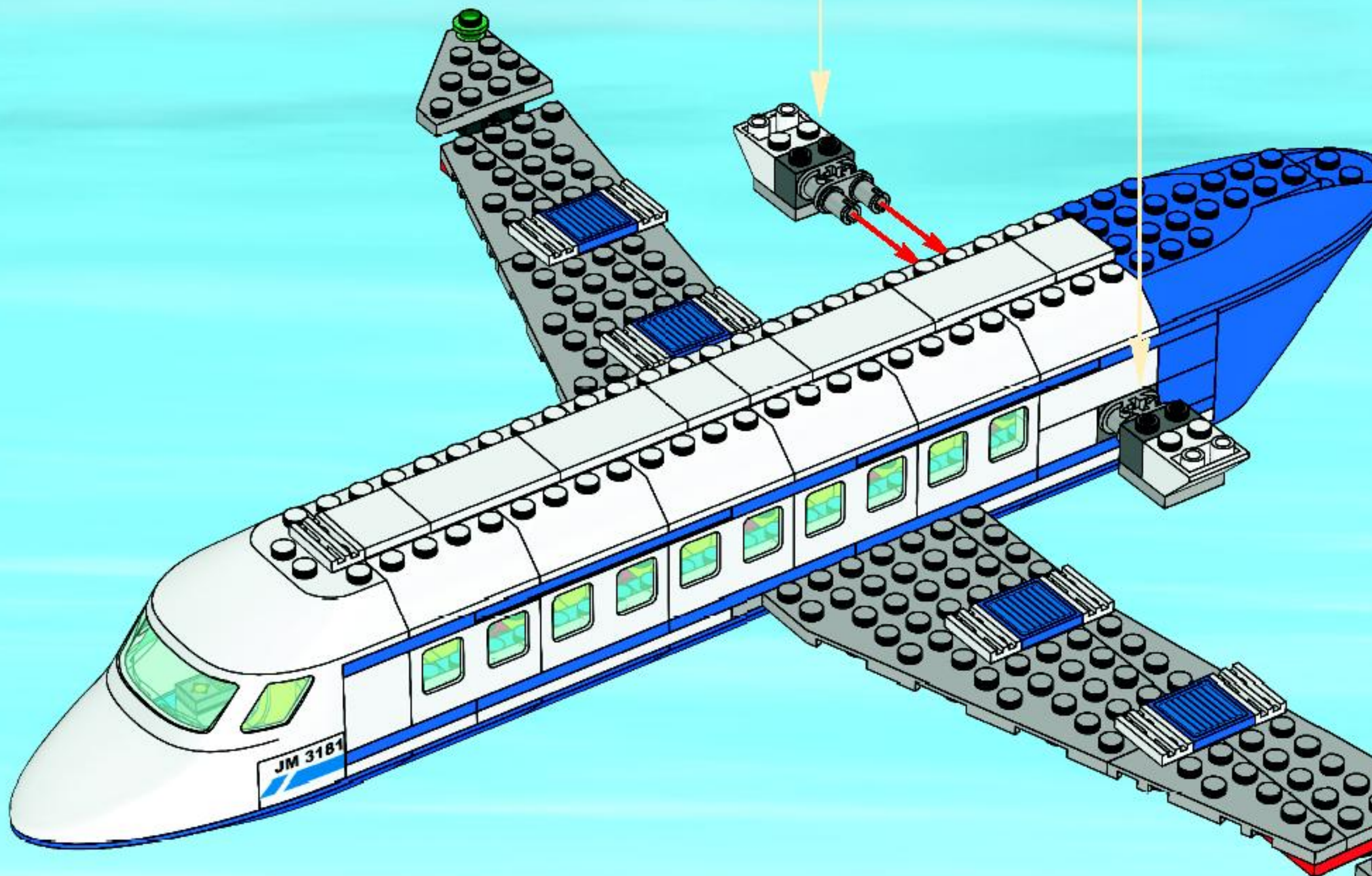



1



2

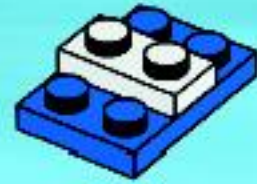

3

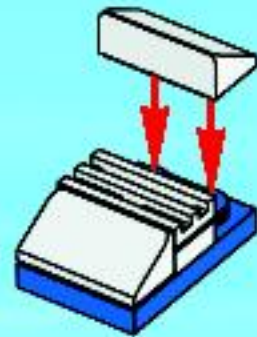

4

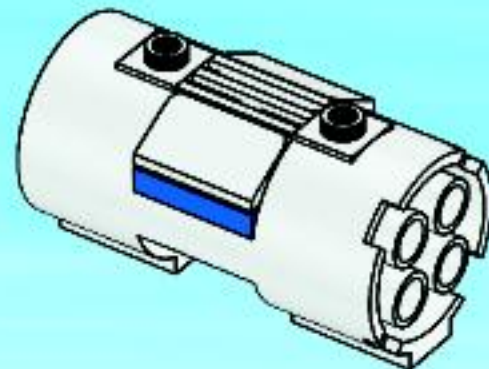

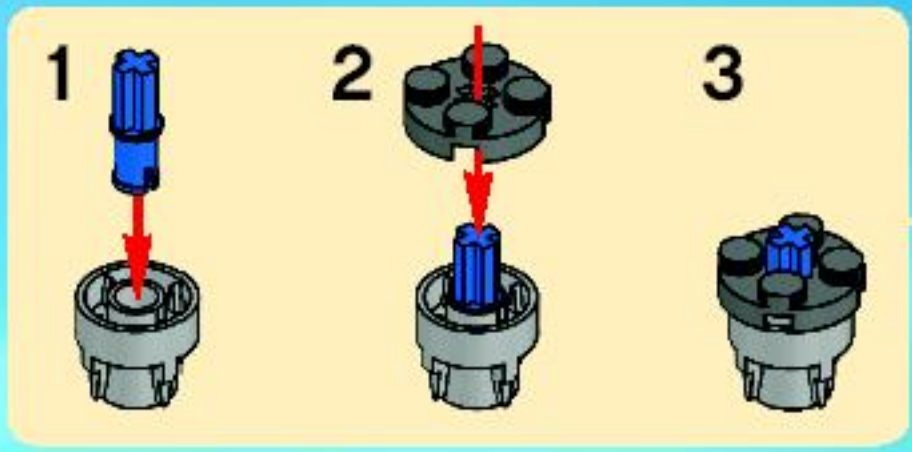

5

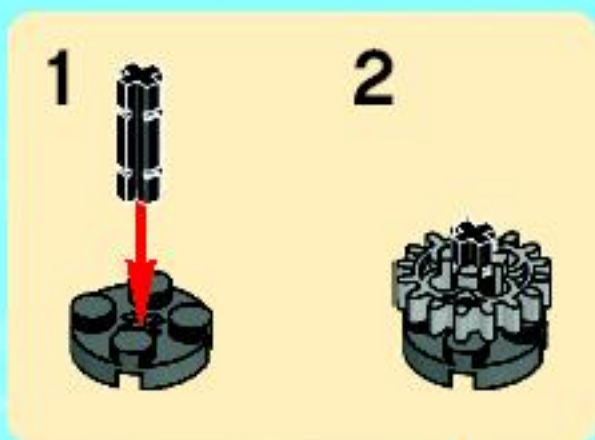
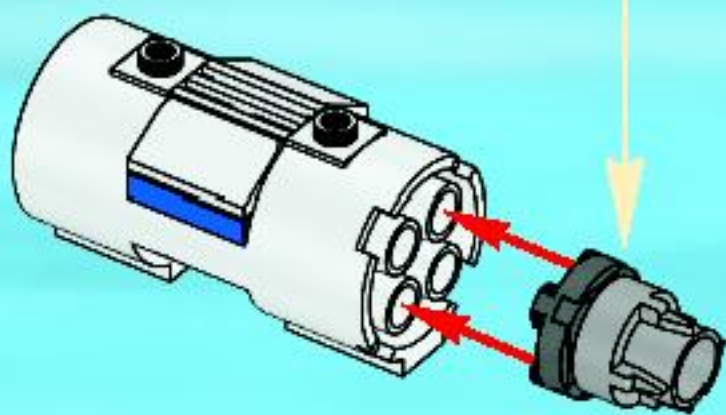

6

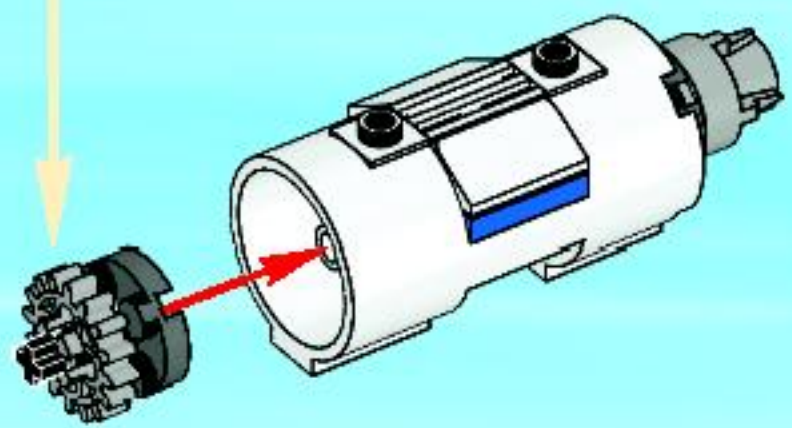

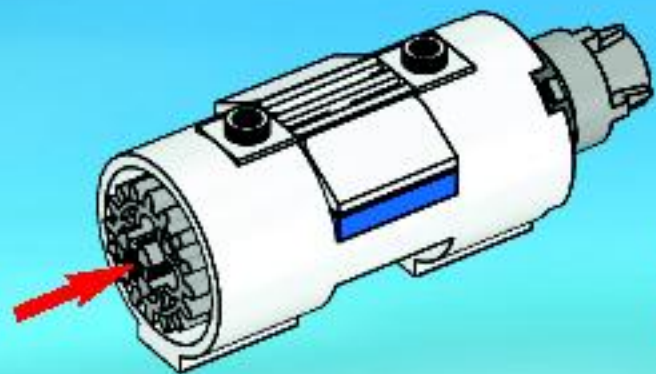

2x

35

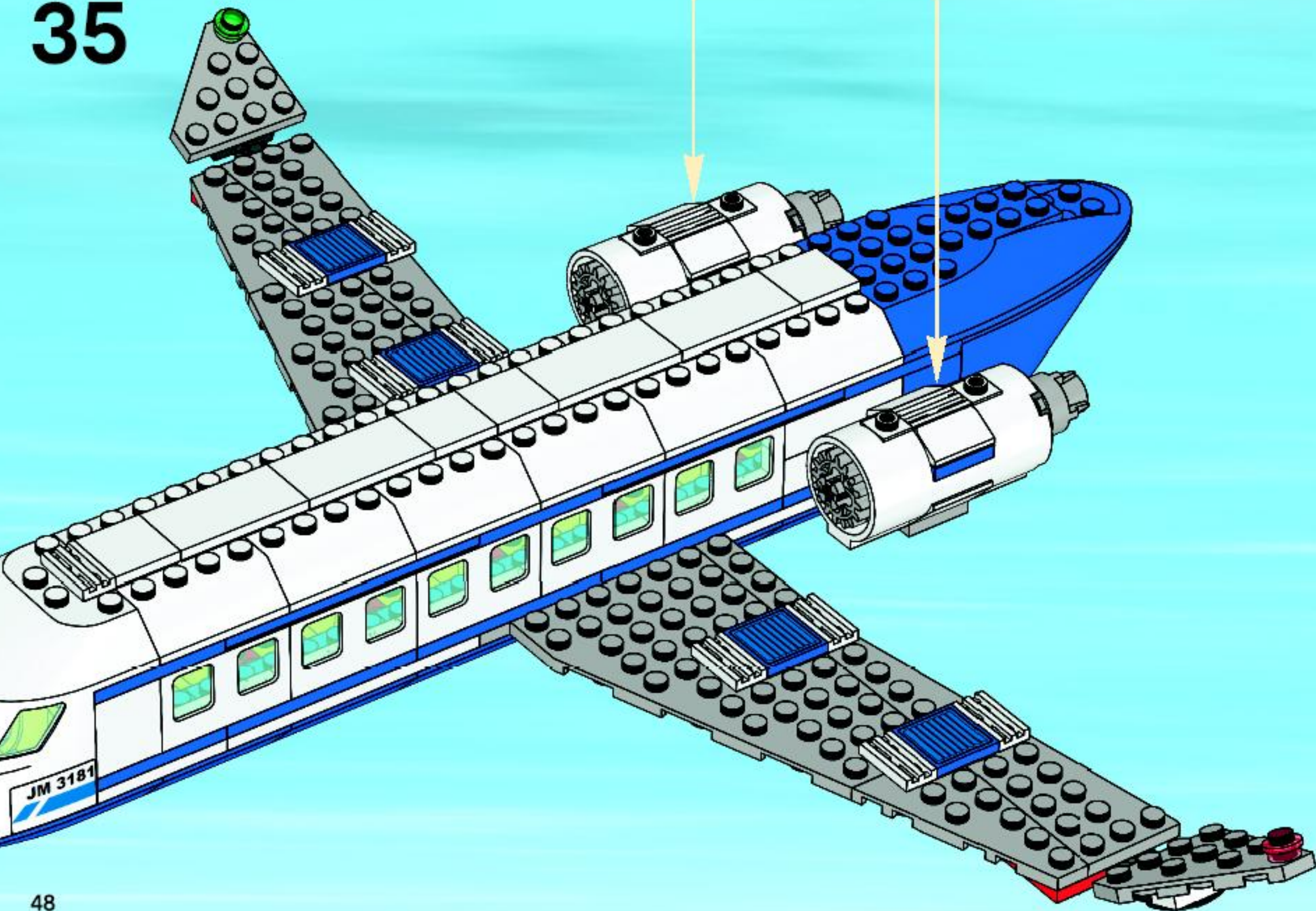

36

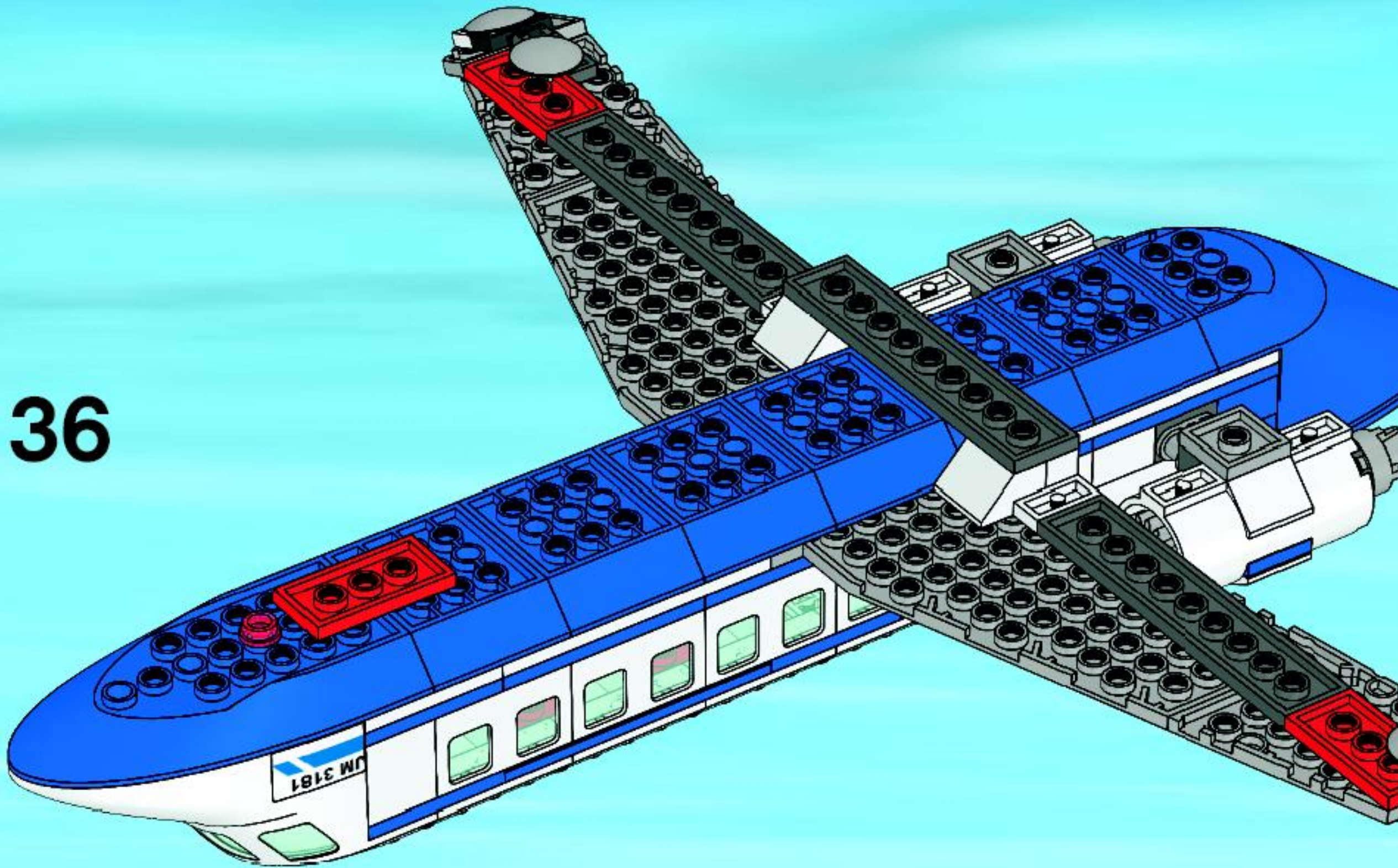

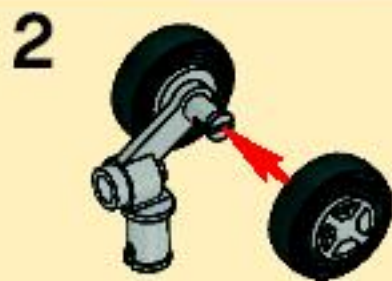

37

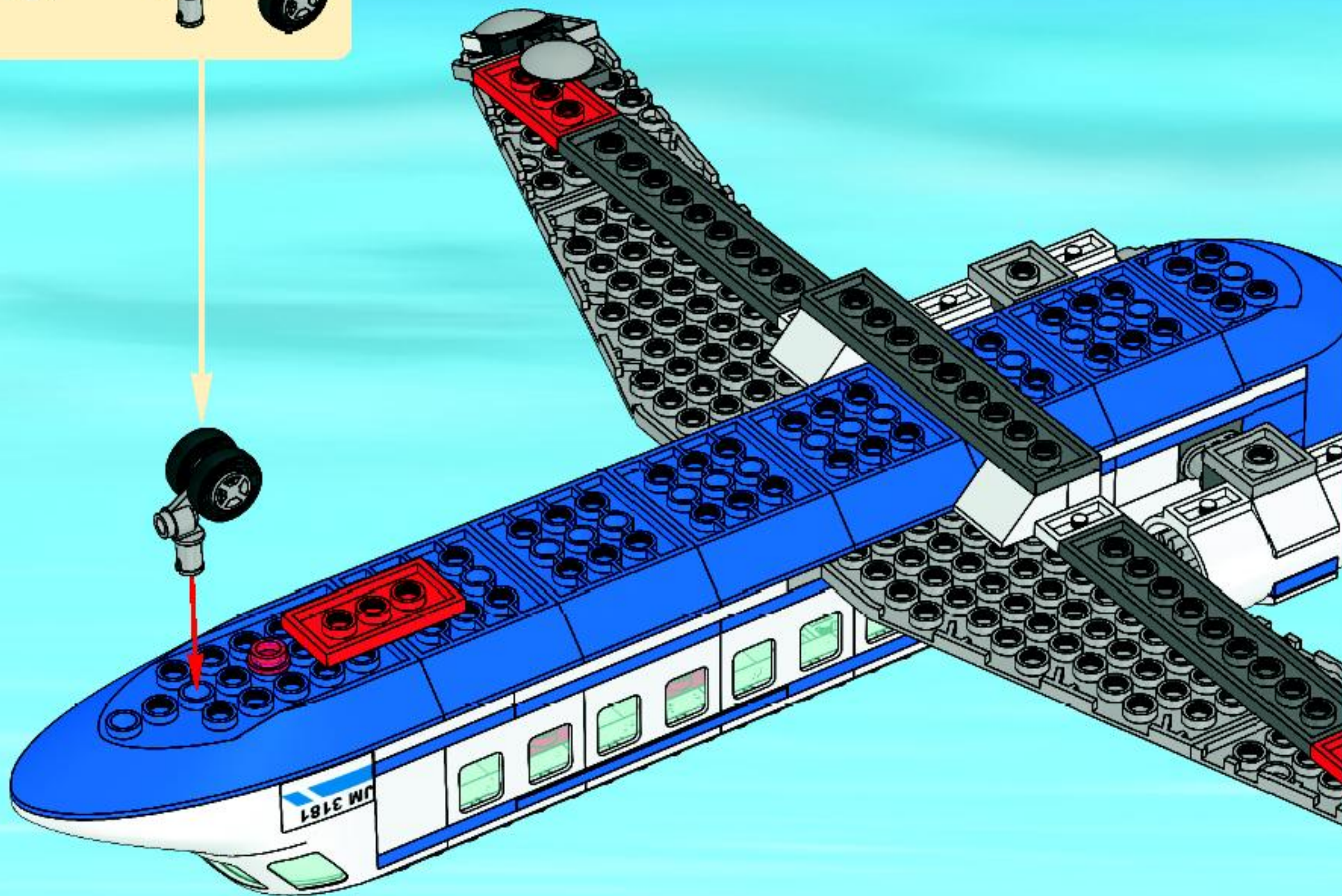

38

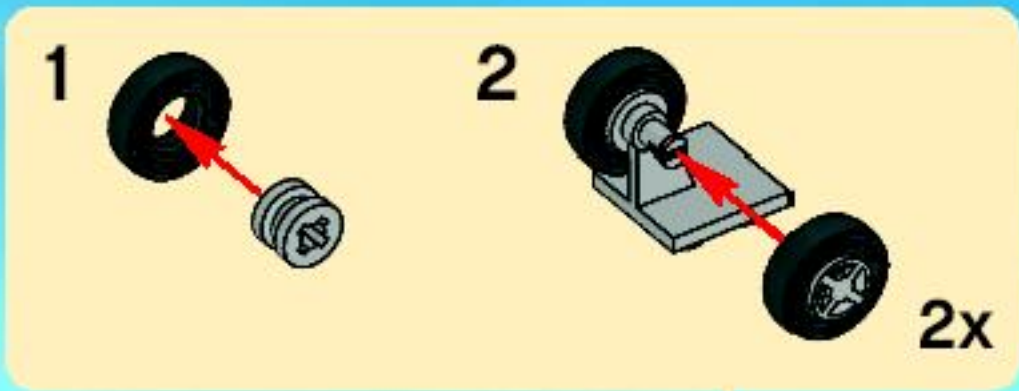

39

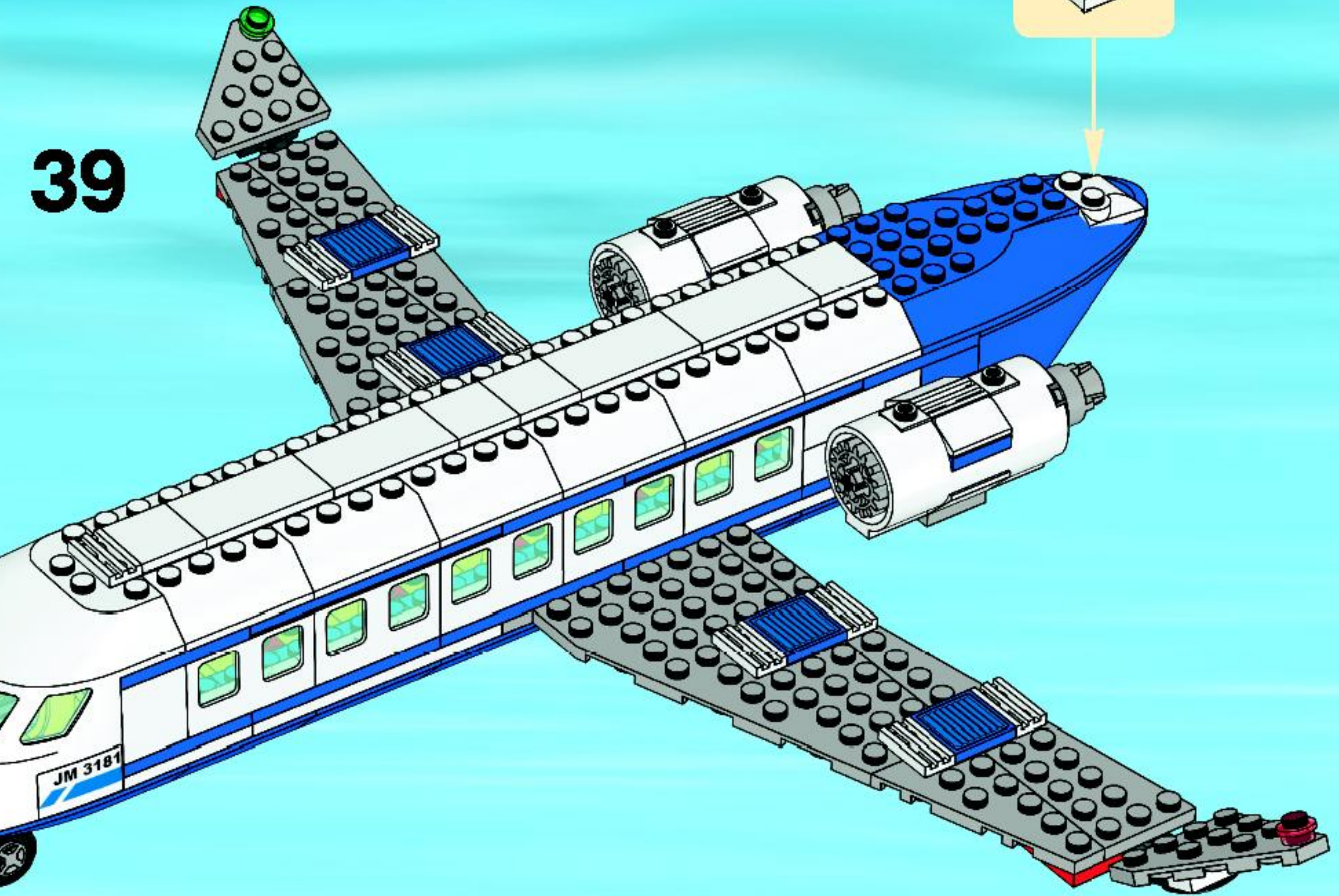

1

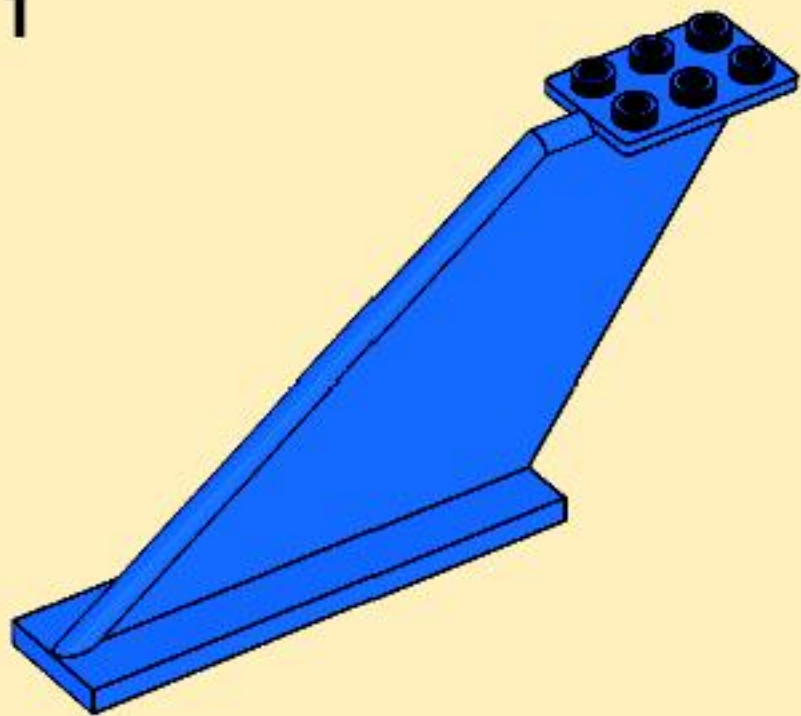

2

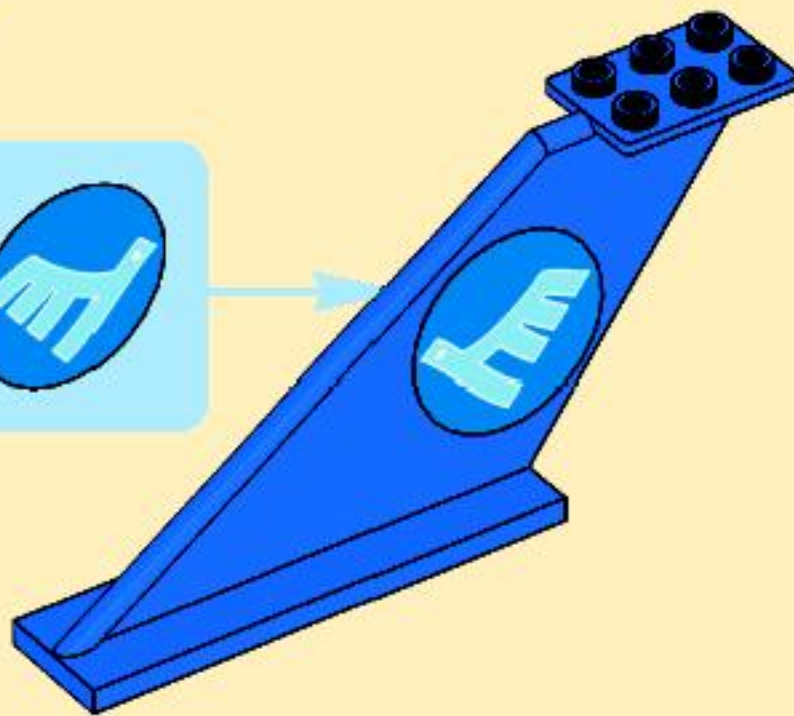

40

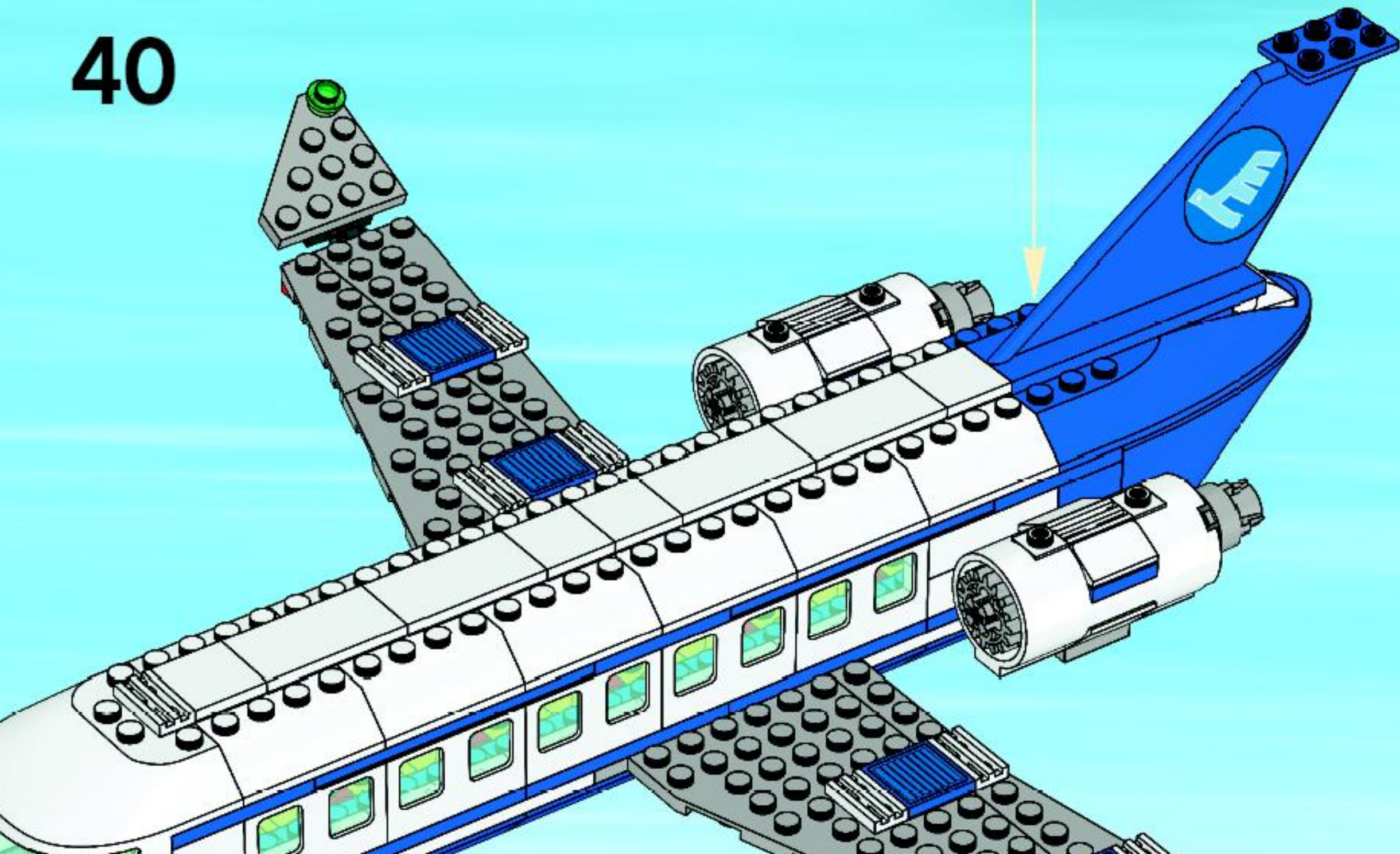

1

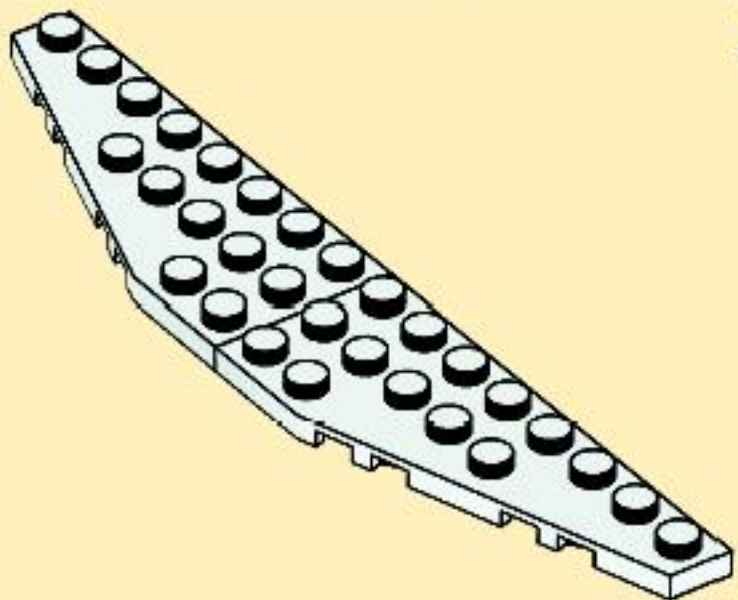

2

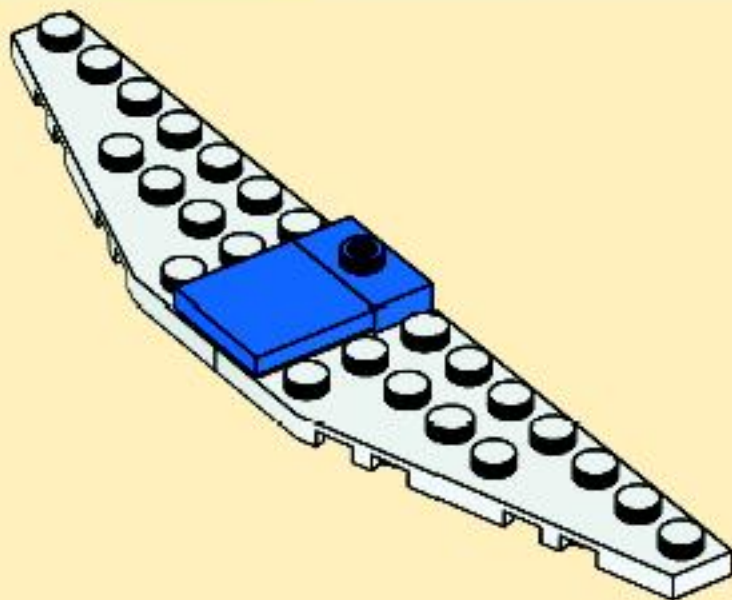

3

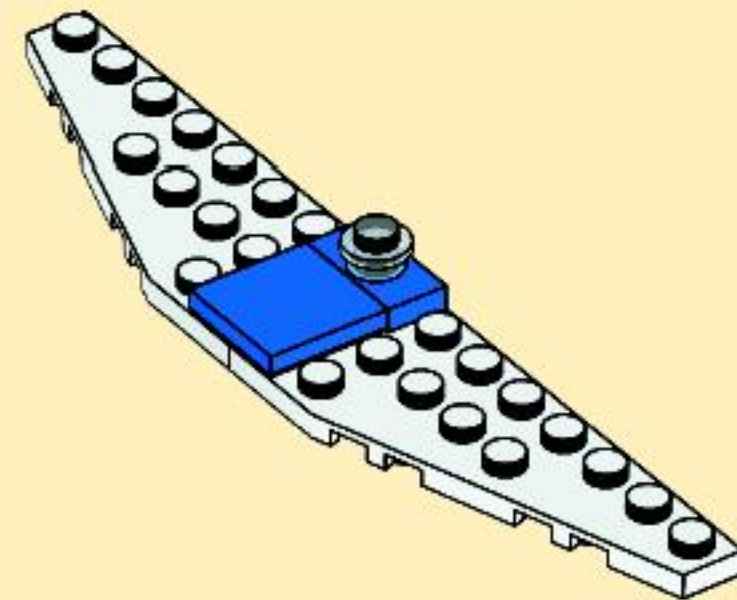

41

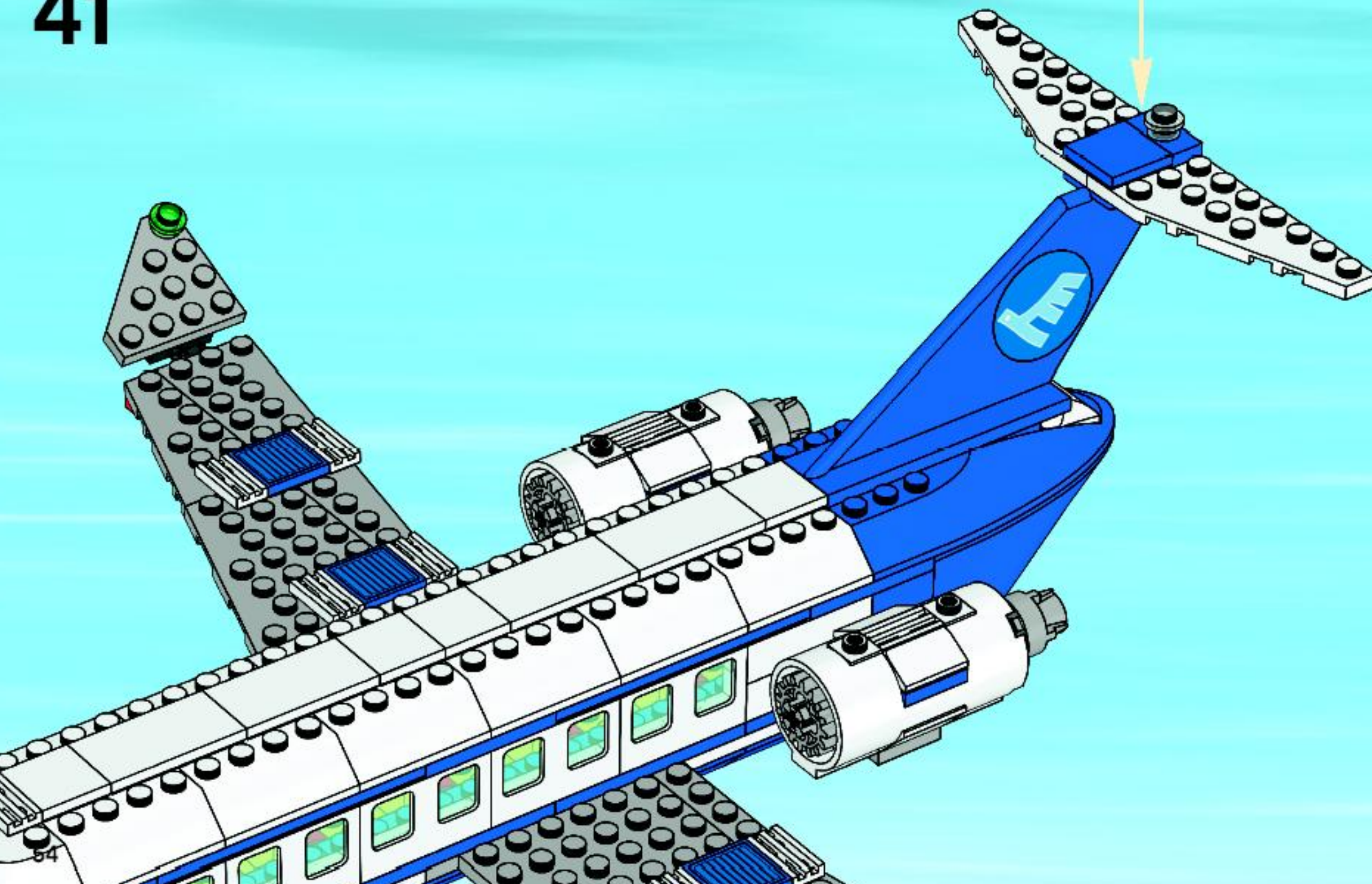

42

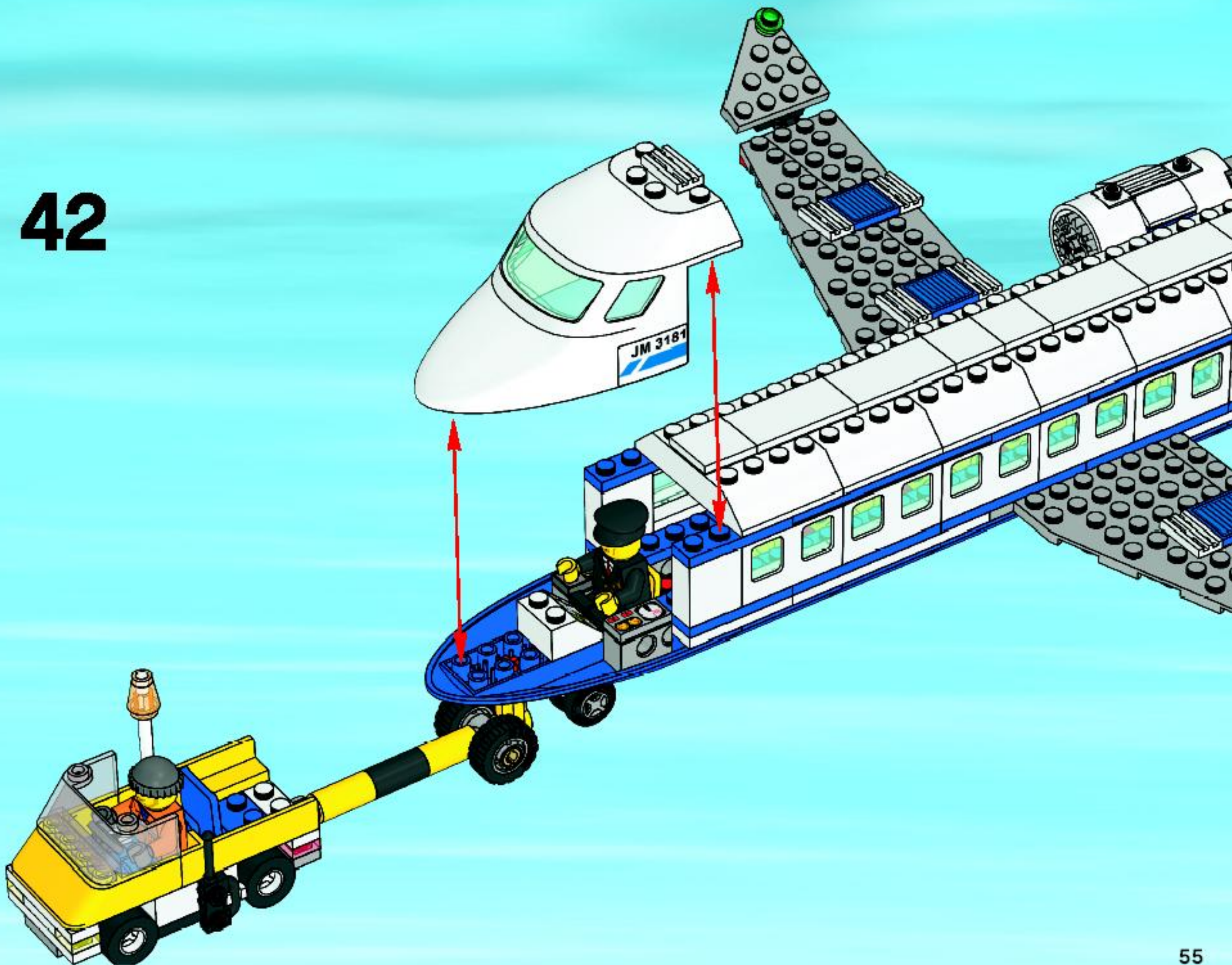



CITY



3177



3178



3179



3180



3181



3182

FREE! GRATIS! GRATUIT!



club MAGAZINE™

www.LEGOclub.com



00800 5346 5555*

1-866-534-6258 • 1-877-518-5346

US & Canada only

Canada seulement

VISIT THE WORLD'S BIGGEST LEGO® SHOP!

www.LEGOshop.com

* Freephone. Mobile charges may apply. ** Numéro sans Frais. Les Frais peuvent s'appliquer avec les téléphones cellulaires. *** Gebührenfrei. Kosten für Anrufer aus Mobilfunknetzen können anfallen. **** Gratisk telefonnummer vanaf vastbelij. ***** Het erelt gratis nummer, naar ringer Pri Postbeli. ***** Debit gratis, naar ringer Pri Post tele fon.

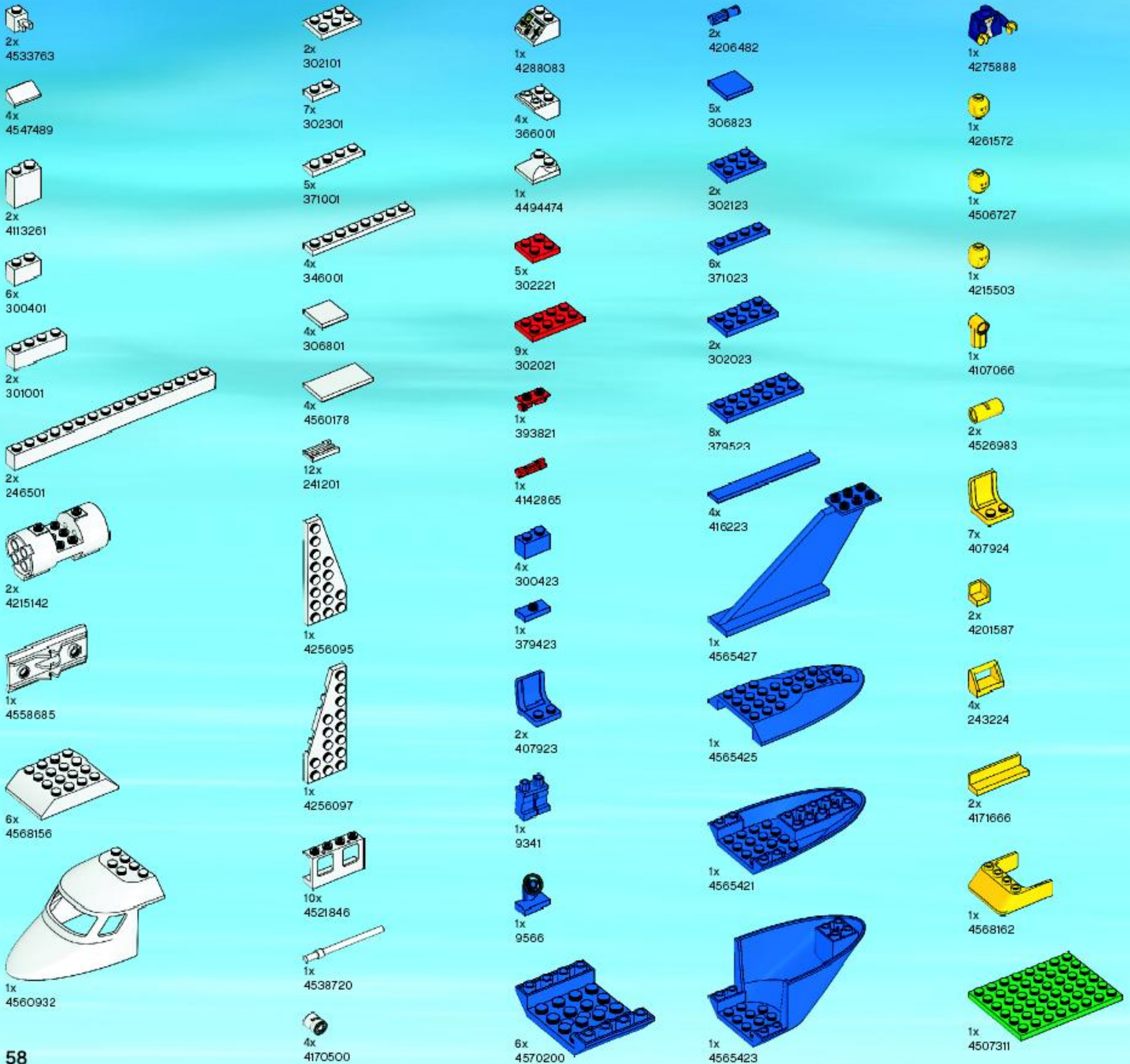



Customer Service

Kundenservice

Service Consommateurs

Servicio Al Consumidor

www.lego.com/service or dial



00800 5346 5555

1-800-422-5346



WIN!

Go to www.nielsen.com/LEGO to fill out a survey for a chance to win a cool LEGO® Product.

No purchase necessary.

Open to all residents where not prohibited.



www.nielsen.com/LEGO

GEWINNE! WIN!

Nimm an der Umfrage auf www.nielsen.com/LEGO teil und hab die Chance ein cooles LEGO Produkt zu gewinnen!

Die Teilnahme am Gewinnspiel führt zu keinerlei Kaufverpflichtungen. Teilnahme in allen nicht ausgeschlossenen Ländern möglich.

Ga naar www.nielsen.com/LEGO, vul een enquêteformulier in en maak kans op een cool LEGO® product.

Geen aankoopverplichting. Iedereen mag deelnemen, uitgezonderd ingezetenden van landen waar een enquêteverbod geldt.

GAGNE! 当てよう!

Visite www.nielsen.com/LEGO pour répondre à un questionnaire et avoir une chance de gagner un produit LEGO® très cool!

Aucune obligation d'achat. Ouvert à tous les résidents des pays autorisés.

www.nielsen.com/LEGOにアクセスして、アンケートにご記入ください。当選者にはレゴ製品を差し上げます。

お買い上げの必要はありません。

禁止されていない限り、すべての国域にご利用いただけます。