



BBC

DOCTOR WHO

21304



Booklet available in English on
Livret disponible en français sur
Folleto disponible en español en www.LEGO.com/ideas

 LEGO.com/ideas

Doctor Who

The Doctor is a Time Lord who travels through time and space solving problems and battling injustice across the universe. His old and occasionally unreliable time machine, the TARDIS, looks like a small British police box on the outside, but is much, much larger on the inside. As a Time Lord, the Doctor cannot die; instead he “regenerates” into a new body and takes on a new personality each time.

The cult BBC science fiction series, *Doctor Who*, first made its appearance in 1963 and is still immensely popular more than 50 years later, after 800 episodes and 12 different Doctors.



The Eleventh Doctor



Fascinated by both the largest and tiniest of things, the Eleventh Doctor has a powerful sense of what is right and wrong. His dress sense might be a bit odd, but he knows that bow ties are cool!

The Eleventh Doctor had grown old on Trenzalore and as the Dalek armies gathered to see him finally defeated, Clara persuaded the Time Lords to grant him a new regeneration cycle.

After destroying his old enemies he reached the TARDIS, phoned the future and completed his regeneration. The era of the fierce, fiery Twelfth Doctor was beginning...

The Twelfth Doctor



Sharp, impatient and with a lightning-fast thought process, the Twelfth Doctor may not be big on hugs, but he is drawn to danger and is incredibly brave.

The Daleks



Created by the evil scientist Davros, the Daleks were born without any compassion or pity and have a strong belief that they are the superior creatures in the Universe.

Clara Oswald



Clara is the Doctor's extraordinary companion. Kind, cheeky and optimistic, she travels with the Doctor and is always in the middle of his most exciting adventures.

Weeping Angel



The Weeping Angels have the ability to send other beings into the past. They then feed on the potential time energy of what would have been the rest of their victim's lives.

The TARDIS



When the Doctor first touched the TARDIS console he said the ship was the most beautiful thing he'd ever known. Then he took off, crashing through the cosmos, saving people and planets, and being taken where he needed to go by his magnificent time machine.

Doctor Who

Le Docteur est un Seigneur du Temps qui voyage dans le temps et l'espace pour résoudre des problèmes et lutter contre l'injustice dans l'univers. Sa machine à voyager dans le temps, vieille et parfois peu fiable, le TARDIS, ressemble à une petite cabine de police britannique de l'extérieur, mais elle est beaucoup, beaucoup plus grande à l'intérieur. En tant que Seigneur du Temps, le Docteur ne peut pas mourir. Il « régénère » un nouveau corps et adopte une nouvelle personnalité à chaque fois.

La série de science-fiction culte de la BBC, *Doctor Who*, fit sa première apparition en 1963 et est toujours immensément populaire après plus de 50 ans, 800 épisodes et 12 Docteurs différents.



Le onzième Docteur



Fasciné par les choses les plus grandes et les plus petites, le onzième Docteur a un sens puissant du bien et du mal. Son style vestimentaire est un peu curieux, mais il sait que les nœuds papillon sont cool !

Le onzième Docteur a vieilli sur Trenzalore et alors que les armées de Daleks se rassemblent pour le voir finalement vaincu, Clara persuade les Seigneurs du Temps de lui accorder un nouveau cycle de régénération.

Après avoir détruit ses vieux ennemis, le Docteur atteint le TARDIS, appelle le futur et termine sa régénération. L'ère du redoutable et fougueux douzième Docteur commence...

Le douzième Docteur



Vif, impatient et avec un processus de réflexion rapide comme l'éclair, le douzième Docteur n'est pas très chaleureux, mais il est attiré par le danger et il est incroyablement courageux.

Les Daleks



Créés par le maléfique scientifique Davros, les Daleks sont nés sans compassion ni pitié et sont convaincus qu'ils sont des créatures supérieures dans l'univers.

Clara Oswald



Clara est la compagne extraordinaire du Docteur. Gentille, espiègle et optimiste, elle voyage avec le Docteur et participe toujours à ses aventures les plus passionnantes.

Ange pleureur



Les anges pleureurs ont la capacité d'envoyer les autres êtres dans le passé. Ils se nourrissent ensuite de l'énergie temporelle potentielle de ce qui aurait été le reste de la vie de leurs victimes.

Le TARDIS



Lorsque le Docteur toucha la console du TARDIS pour la première fois, il déclara que ce vaisseau était la chose la plus belle qu'il ait jamais vue. Puis il décolla, fonçant dans le cosmos pour sauver des gens et des planètes, emmené où il devait aller par cette magnifique machine à voyager dans le temps.

Doctor Who

El Doctor es un Señor del Tiempo que viaja a través del tiempo y el espacio resolviendo problemas y luchando por la justicia en el universo. Su antigua y a veces poco confiable máquina del tiempo, la TARDIS, se ve como una pequeña cabina de policía británica por fuera, pero es mucho, mucho más grande por dentro. Como Señor del Tiempo, el Doctor no puede morir; en su lugar, se «regenera» en un nuevo cuerpo y desarrolla una nueva personalidad cada vez.

La serie Doctor Who, un símbolo de la ciencia ficción creado por la BBC, se emitió por primera vez en 1963. Hoy, más de 50 años después, con 800 episodios emitidos y 12 Doctores diferentes, continúa siendo inmensamente popular.



El undécimo Doctor



Al undécimo Doctor le fascinan las cosas más grandes y pequeñas, y tiene un profundo sentido de lo correcto y lo incorrecto. Puede que su sentido del gusto a la hora de vestirse sea un poco extraño, ipero sabe que las pajaritas son lo mejor!

El undécimo Doctor había envejecido en Trenzalore; sin embargo, cuando los ejércitos de Dalek se reúnen para derrotarlo definitivamente, Clara persuade a los Señores del Tiempo para que le proporcionen un nuevo ciclo de regeneración.

Tras destruir a sus antiguos enemigos, entra en la TARDIS, telefonea al futuro y completa su regeneración. Comenzaba así la era del feroz y apasionado duodécimo Doctor...

El duodécimo Doctor



Astuto, impaciente y rápido como el rayo al pensar, el duodécimo Doctor no es el mejor dando abrazos, pero siente atracción por el peligro y es increíblemente valiente.

Los Daleks

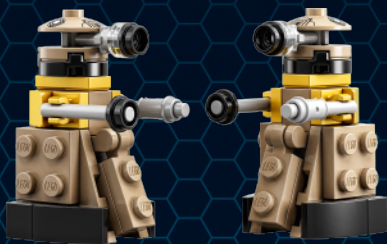

Creados por el malvado científico Davros, los Daleks nacieron sin sentimientos de compasión o pena y están convencidos de que son criaturas superiores en el universo.

Clara Oswald



Clara es la extraordinaria compañera del Doctor. Amable, alegre y optimista, viaja con el Doctor y siempre está metida en sus aventuras más emocionantes.

Ángel llorón



Los ángeles llorones tienen la habilidad de enviar a otros seres al pasado. Al hacerlo, se alimentan de la energía temporal desprendida de lo que habría sucedido durante el resto de la vida de sus víctimas.

La TARDIS



Cuando el Doctor acarició la consola de la TARDIS por primera vez, dijo que la nave era lo más bello que había conocido jamás. Entonces despegó hacia el cosmos a toda velocidad, dispuesto a ayudar a personas y planetas transportándose hasta el lugar en el que se lo requiere en su asombrosa máquina del tiempo.

1



2

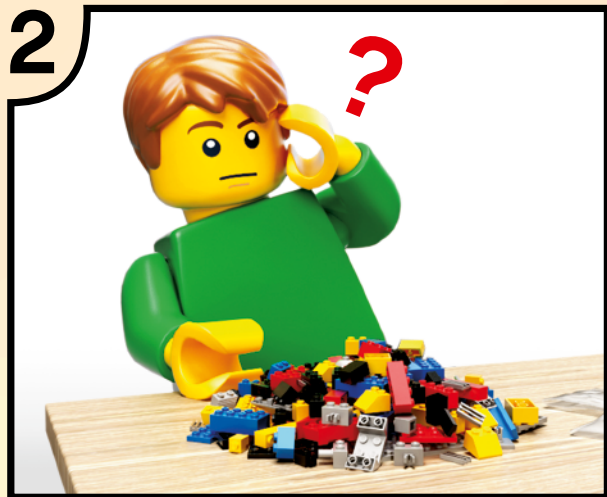

3



4



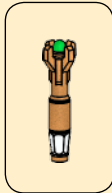
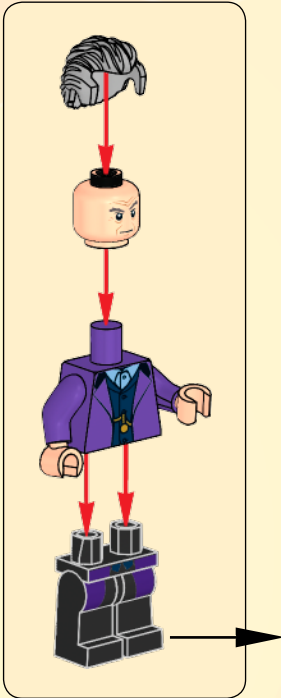
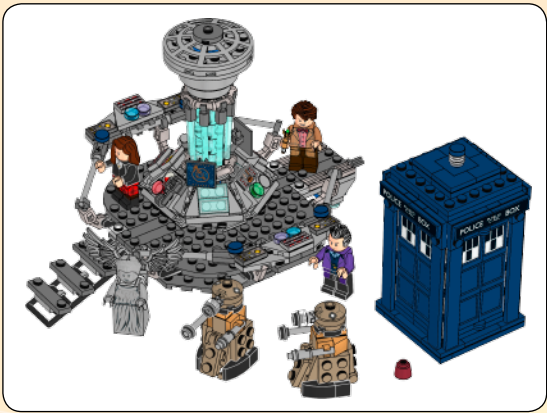

1

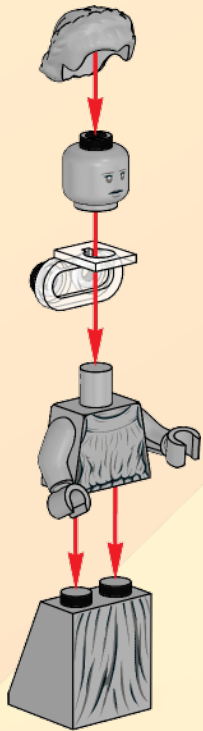

2

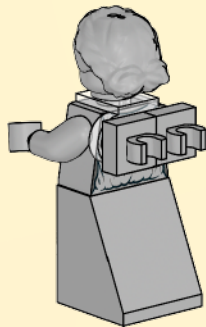
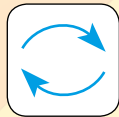

3

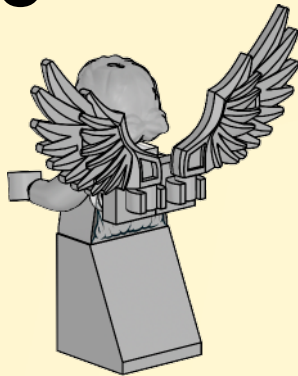

4

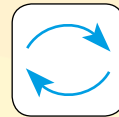

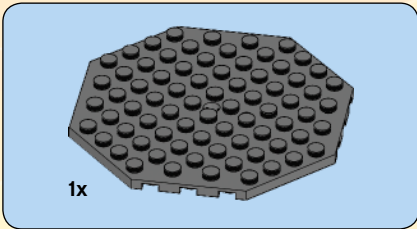
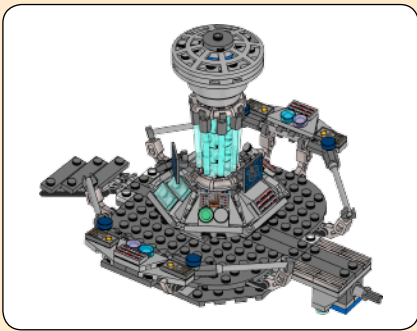

1

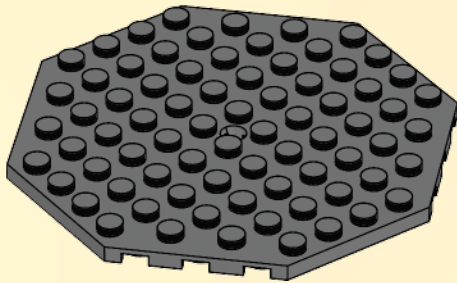

2

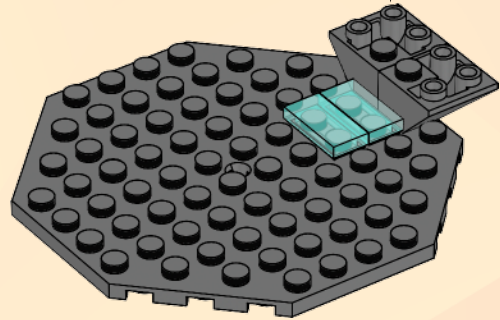
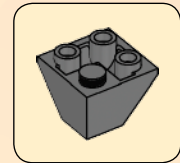



4x

3

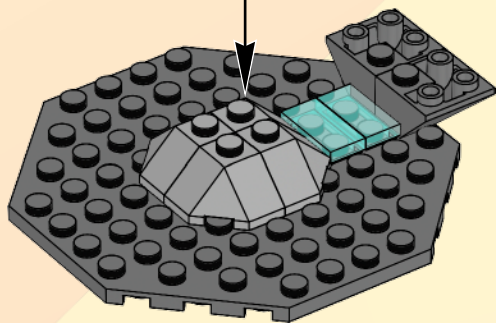
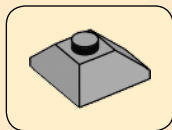

6x

4

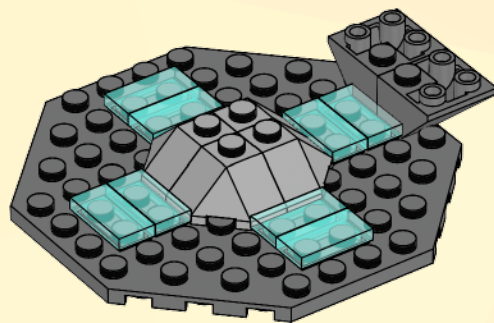

8x

5

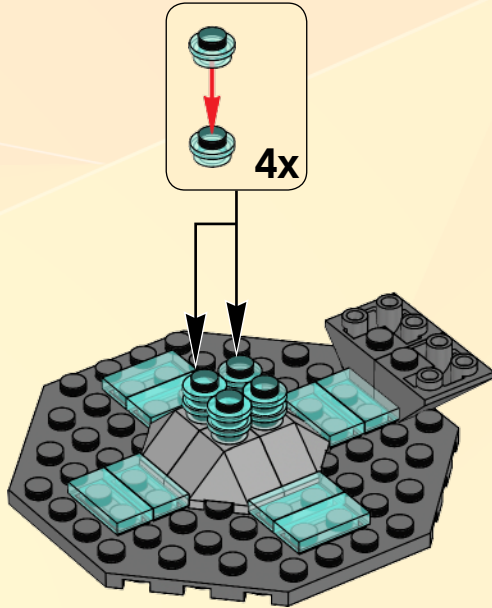

2x



4x



1x

6

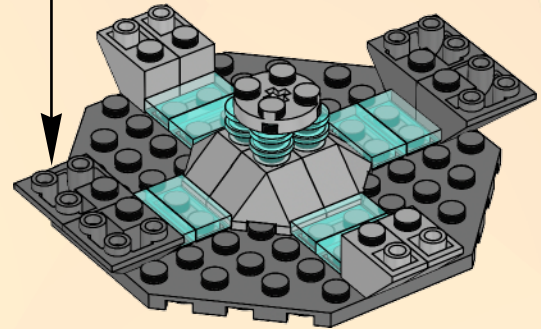
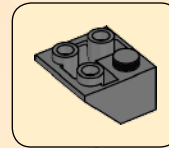

The Doctor never travels without his sonic screwdriver; the multi-purpose tool that can unlock doors, scan bodies and track alien life.

Le Docteur ne voyage jamais sans son tournevis sonique, l'outil multi-fonctions qui peut déverrouiller des portes, scanner des corps et suivre les formes de vie extra-terrestre.

El Doctor jamás viaja sin su destornillador sónico: una herramienta multiusos capaz de abrir puertas, escanear cuerpos y rastrear vida extraterrestre.





2x

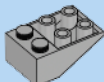

4x

7

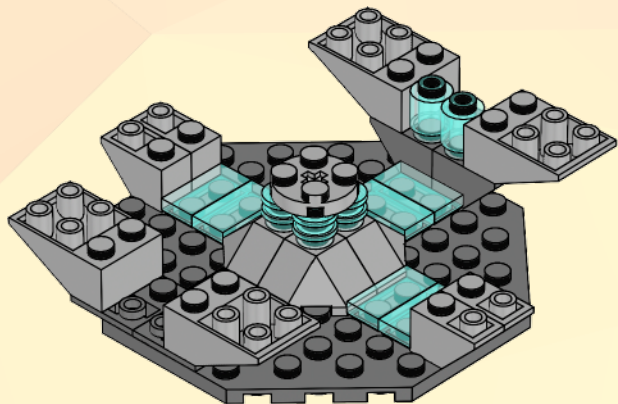

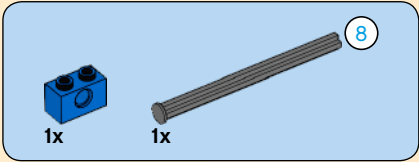
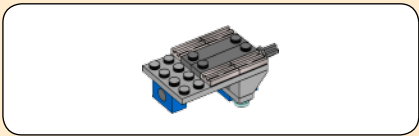

1

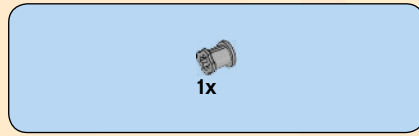
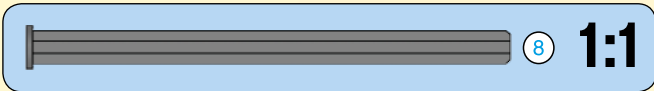
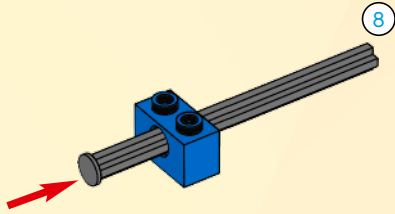

2

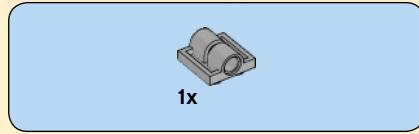
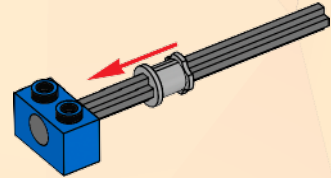

3

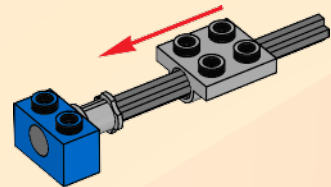



2x

4

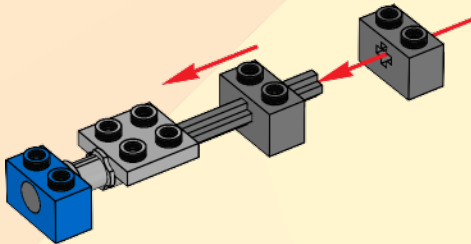
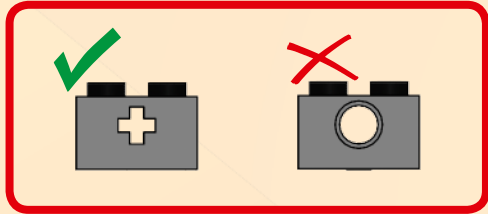

1x

5

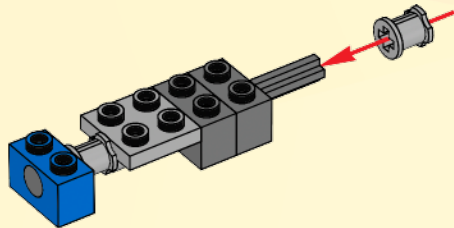

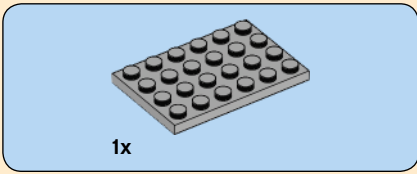

6

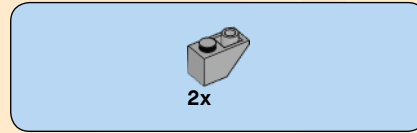
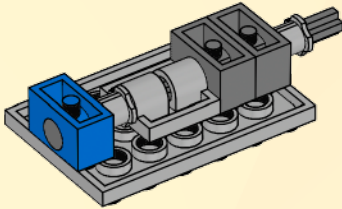
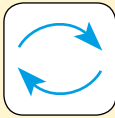

7

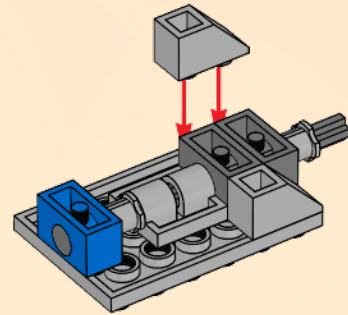



2x

8

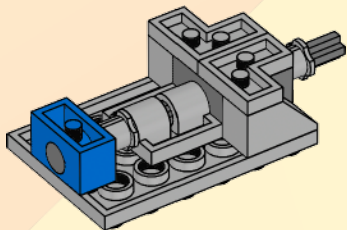

1x



2x

9

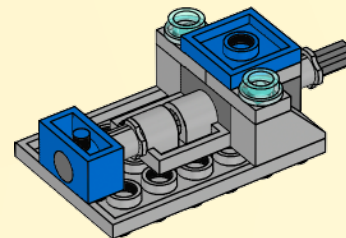

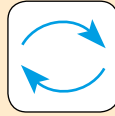
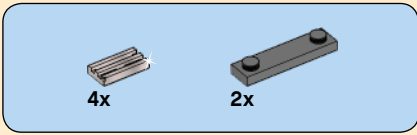

10

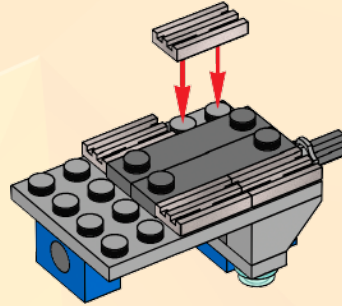

8

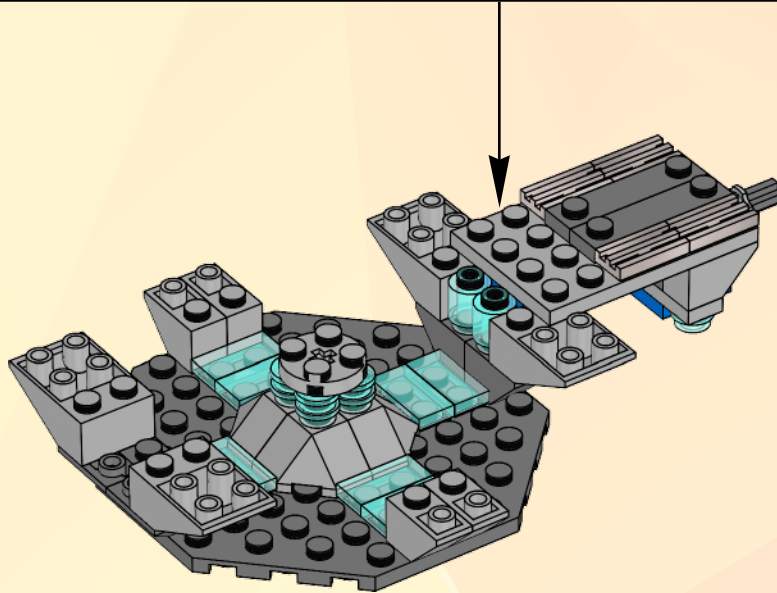

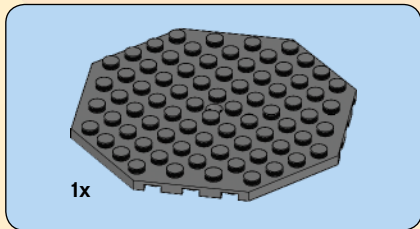

1

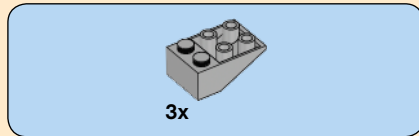
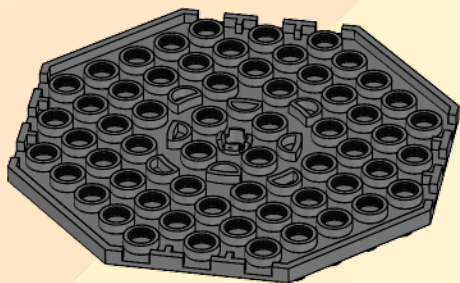

2

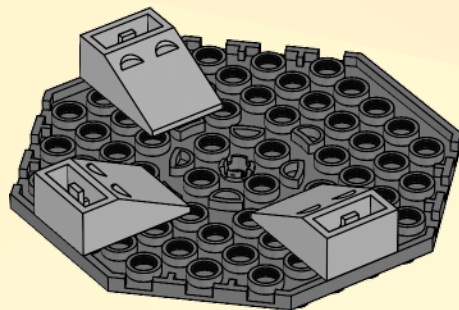

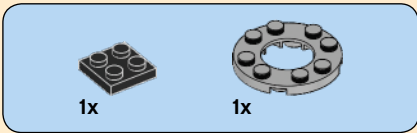

3

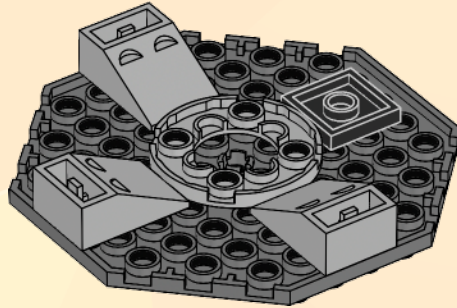

9

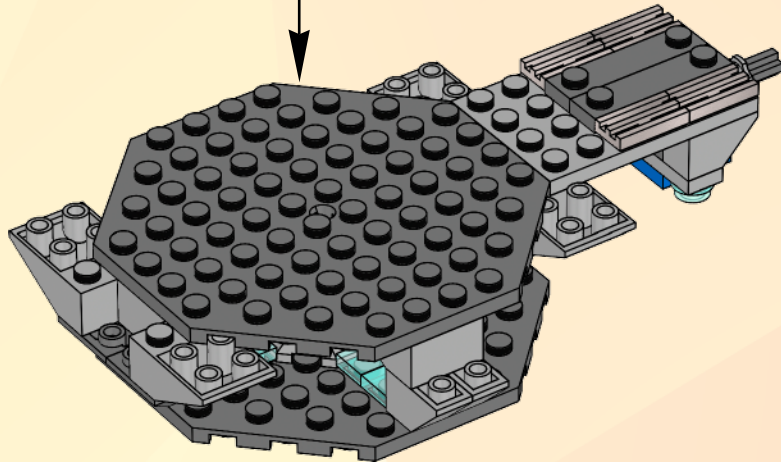



1x



4x

10

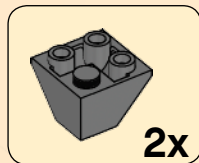

2x

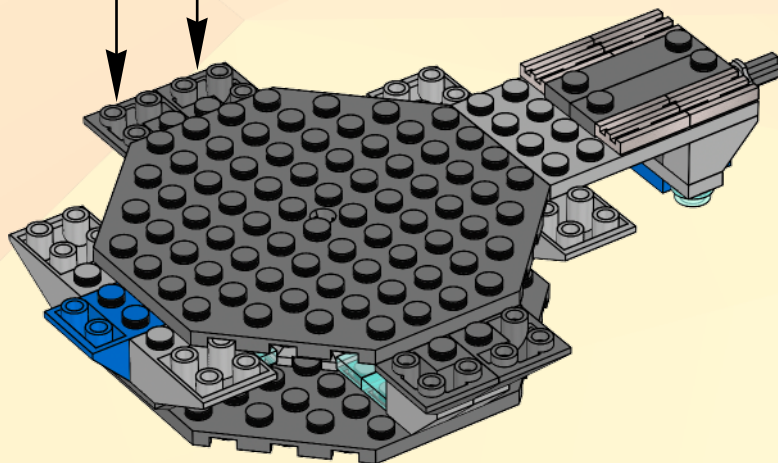

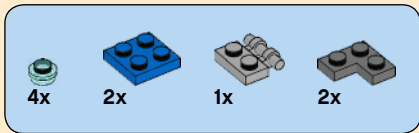

11

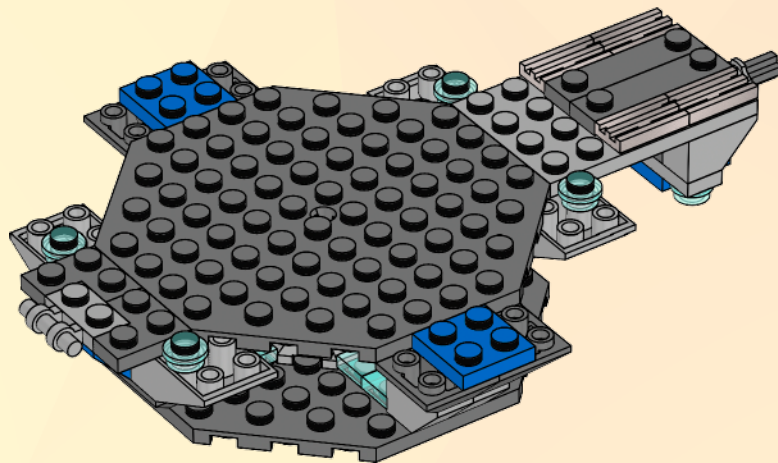



8x

12

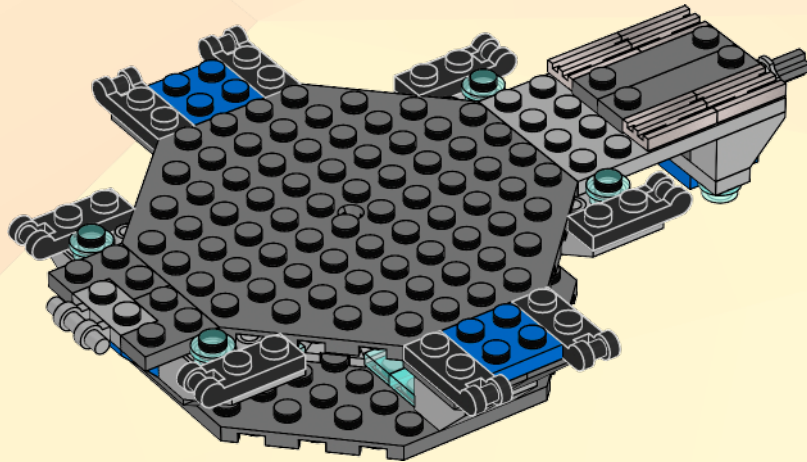



1x



2x



4x

13

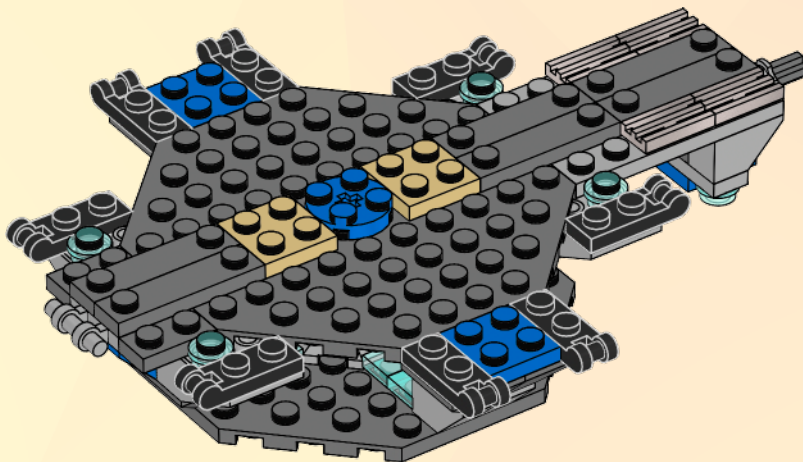

The Weeping Angels only move when no one is looking at them. When observed, they instantly turn into stone.

Les anges pleureurs ne se déplacent que quand personne ne les regarde. Lorsqu'ils sont observés, ils se transforment instantanément en pierre.

Los ángeles llorones sólo se mueven cuando nadie los mira. Al ser observados, se convierten en piedra inmediatamente.



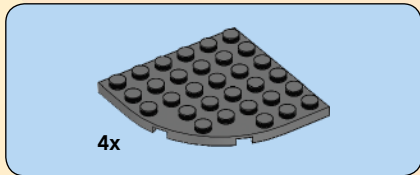

14

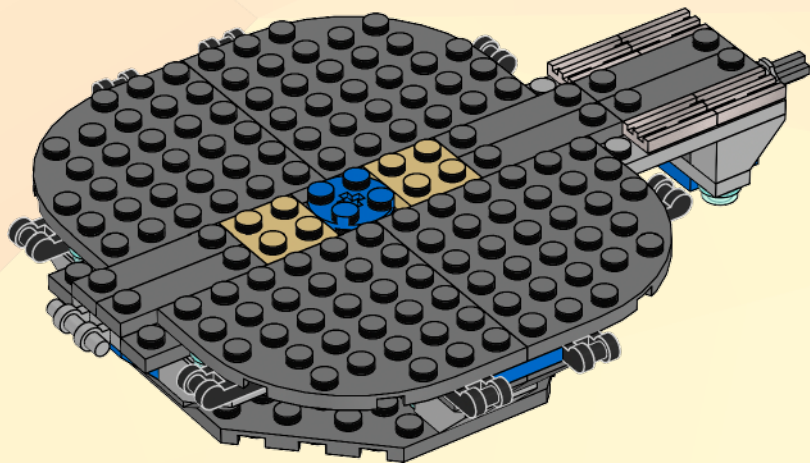



4x

15

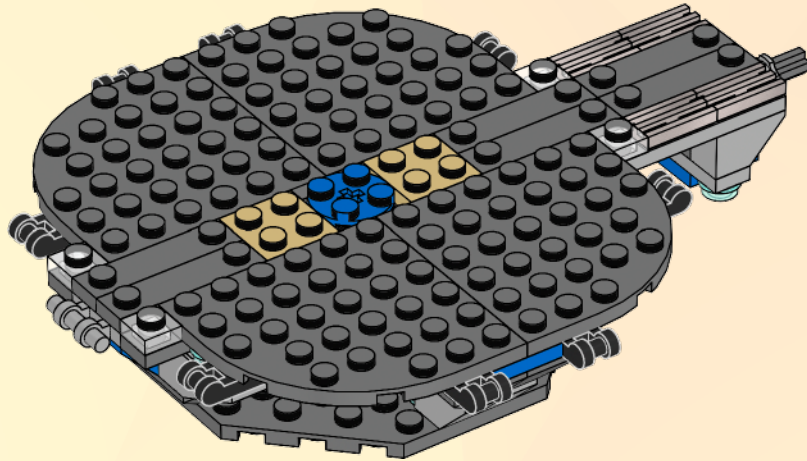



1x

16

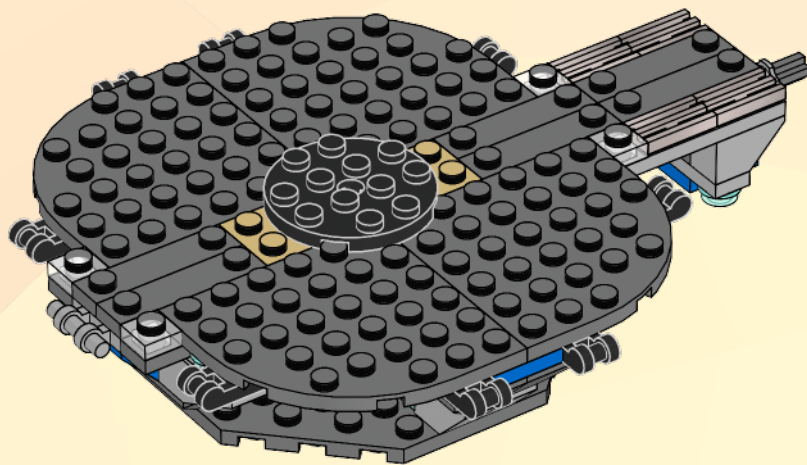

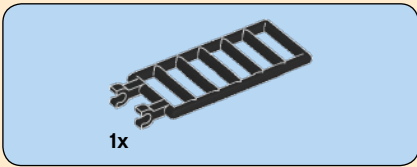

17

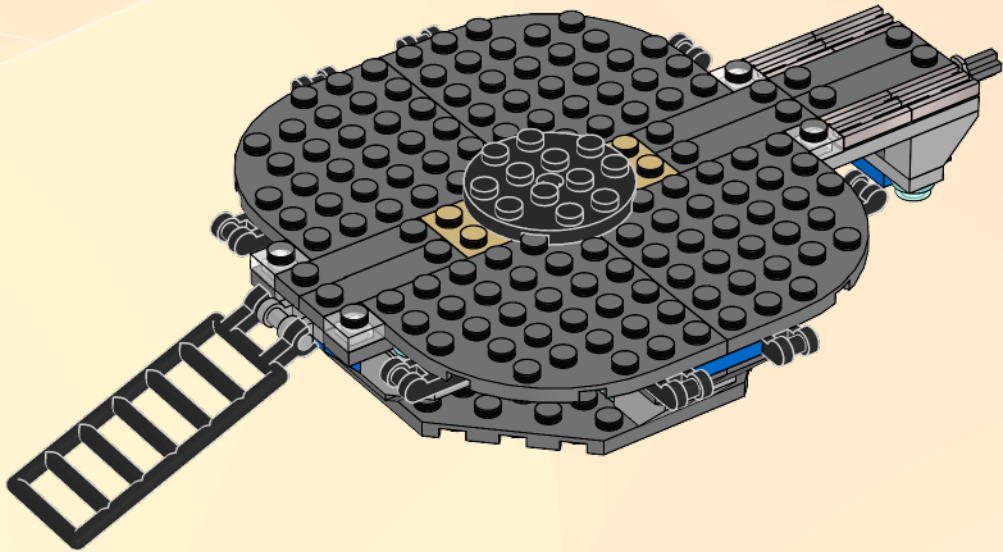

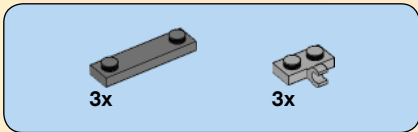

18

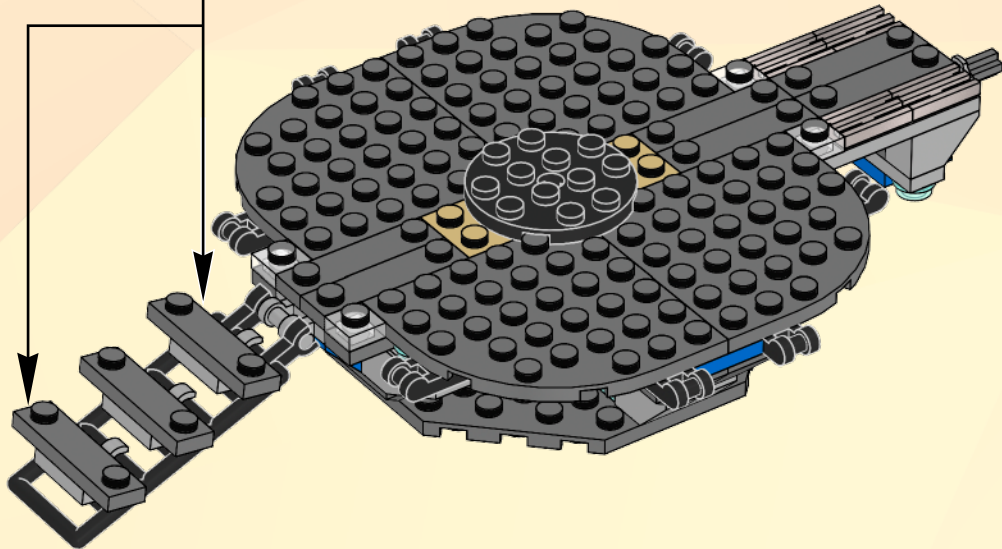
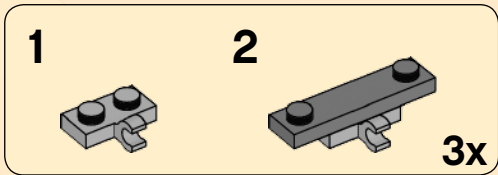



4x

19

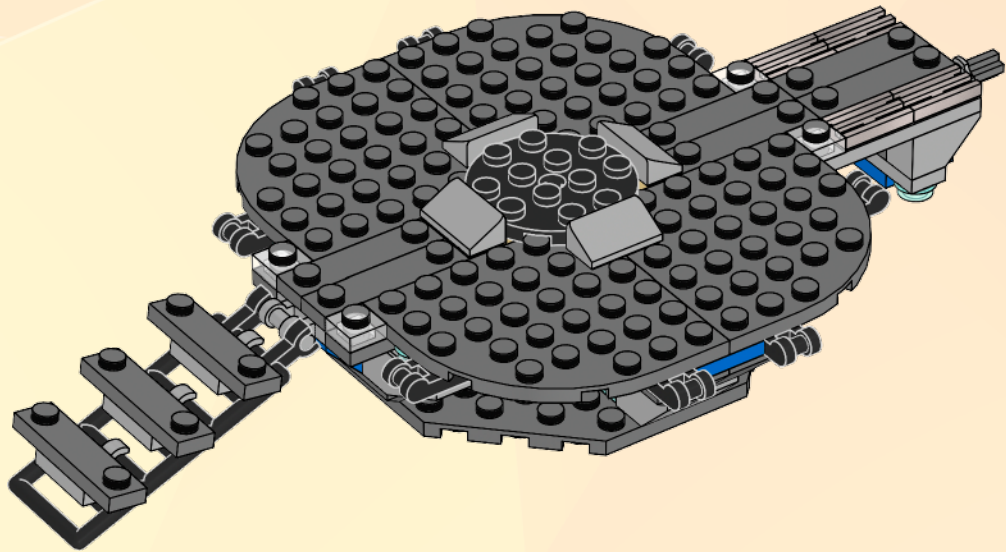



8x



8x

20



8x

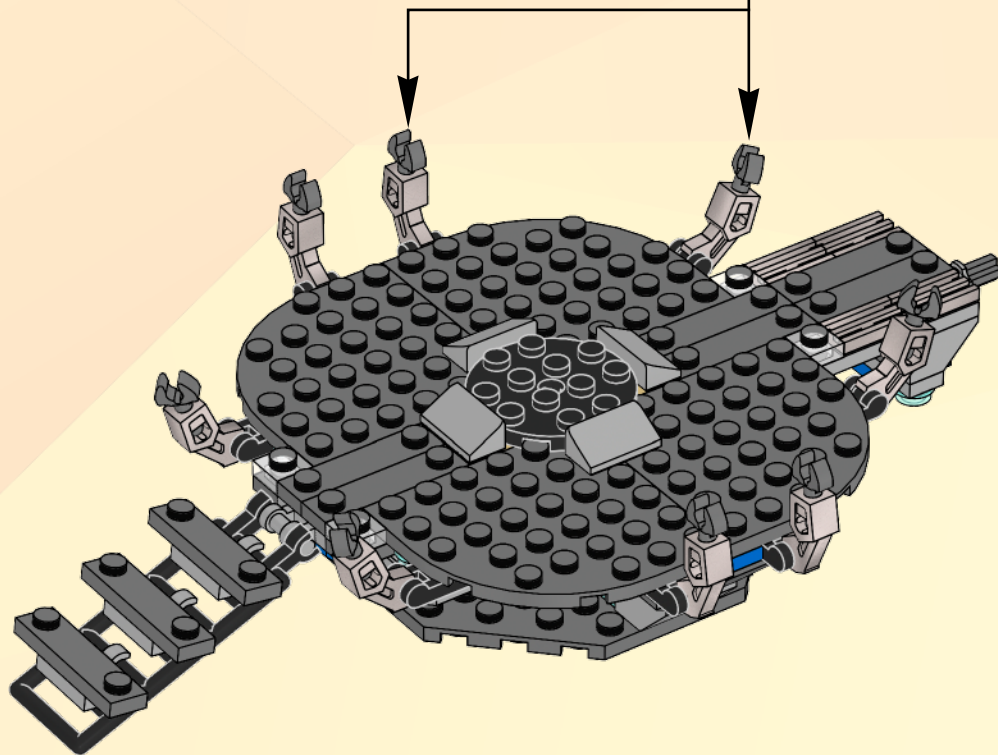

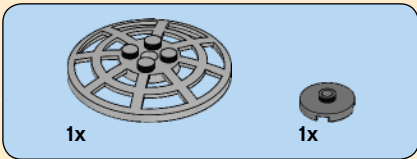
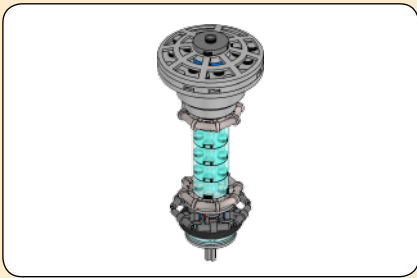

1

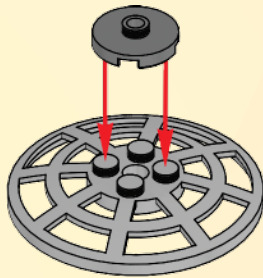

2

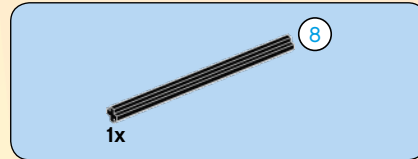
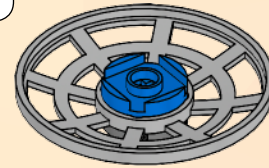
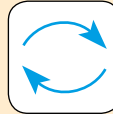

3

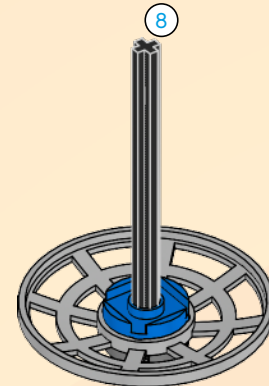

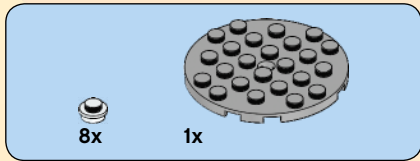

4

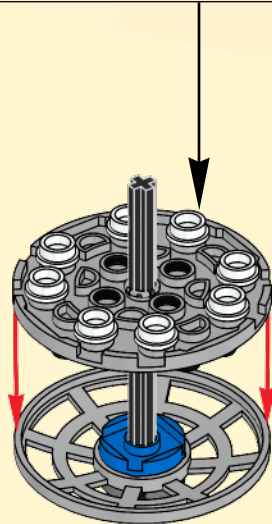
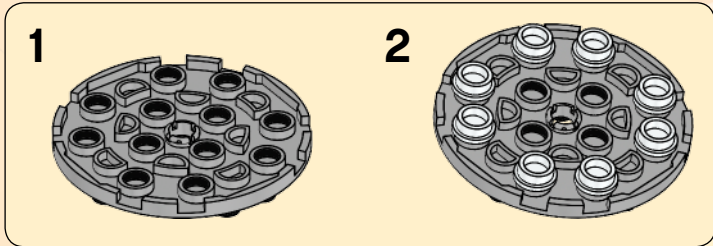

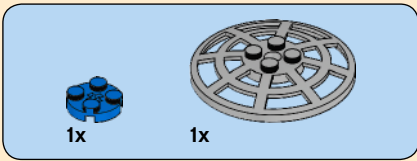

5

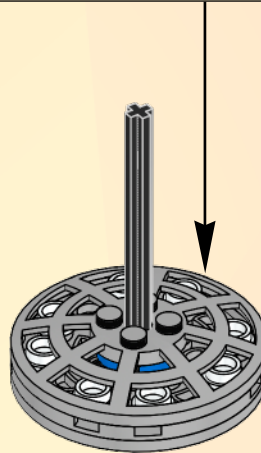
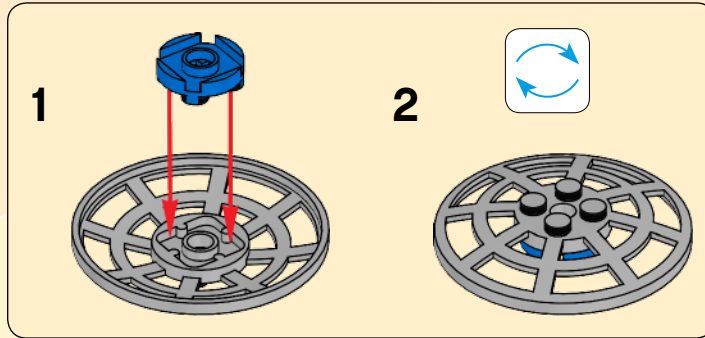



1x



1x

6

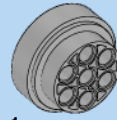
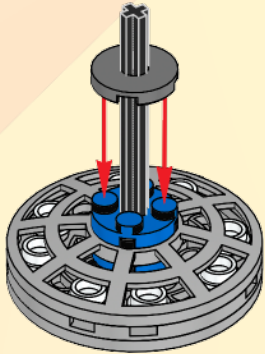

1x

7

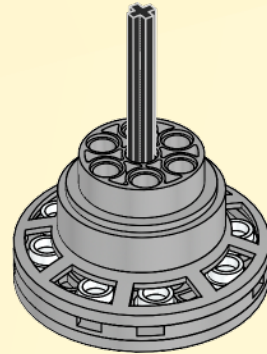



8

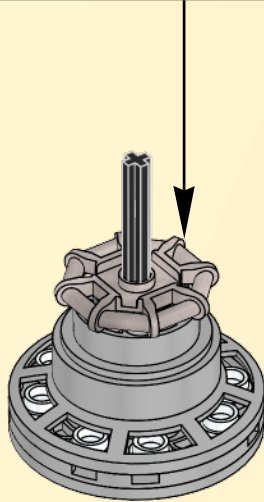
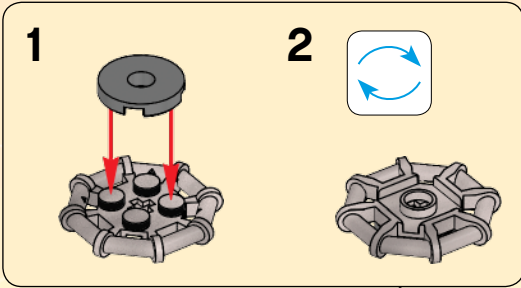

9

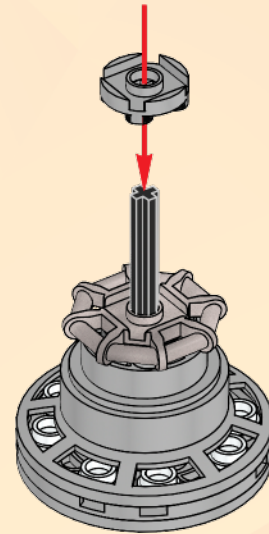



2x

10

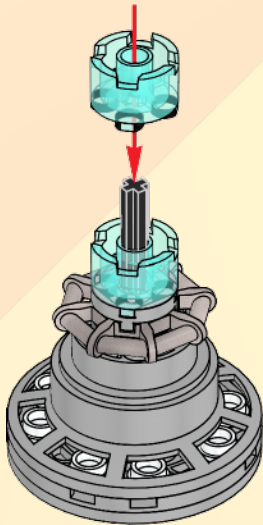

2x

11

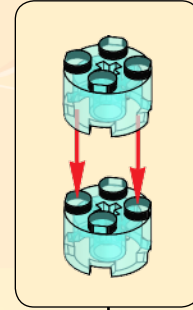

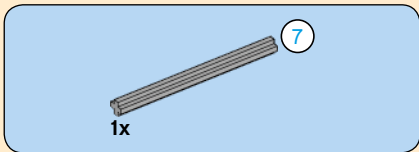

12

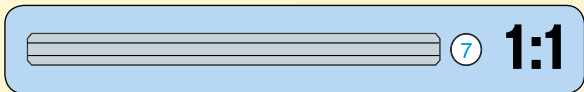
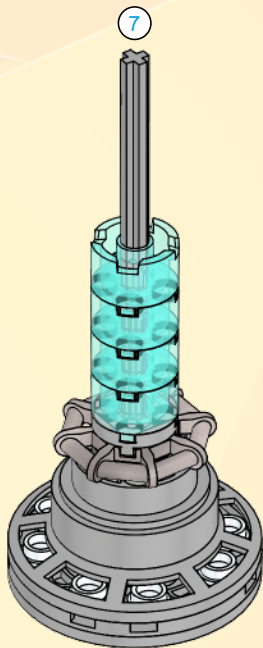

13

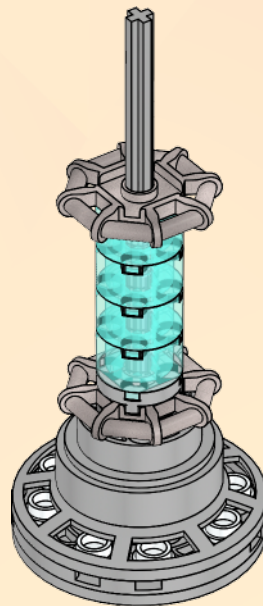



1x

14

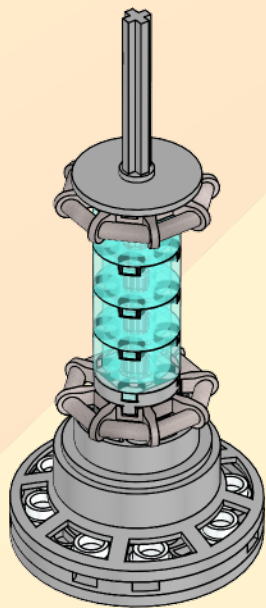

1x

15



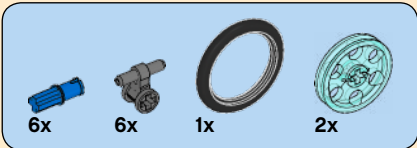

16

1

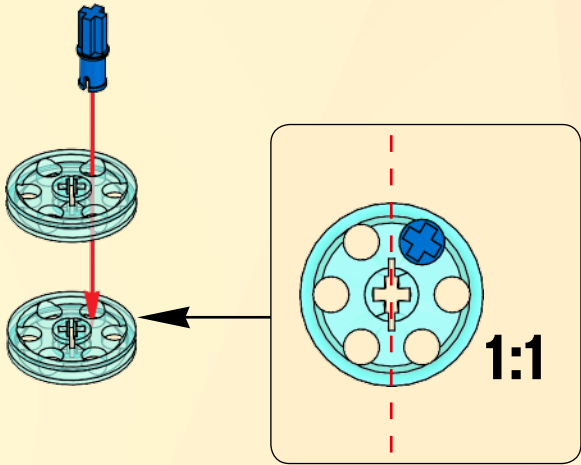

2



3



4

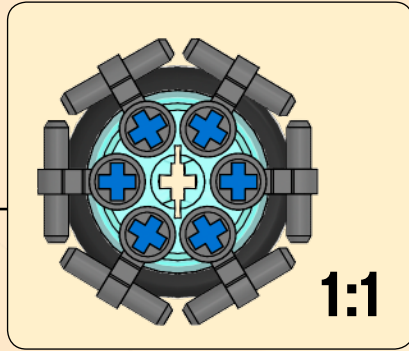

5

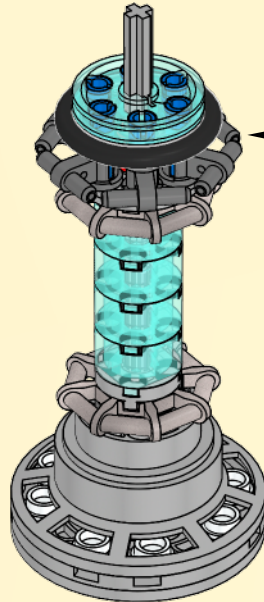
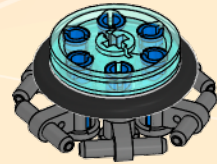
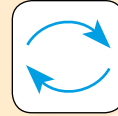

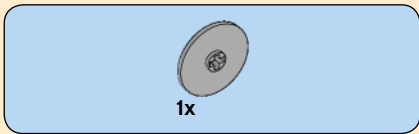

17

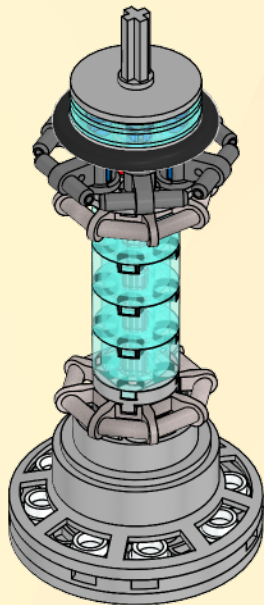

18

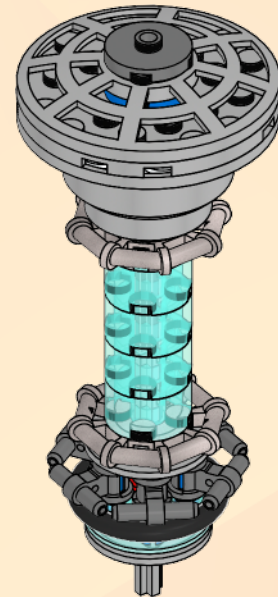
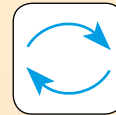

21

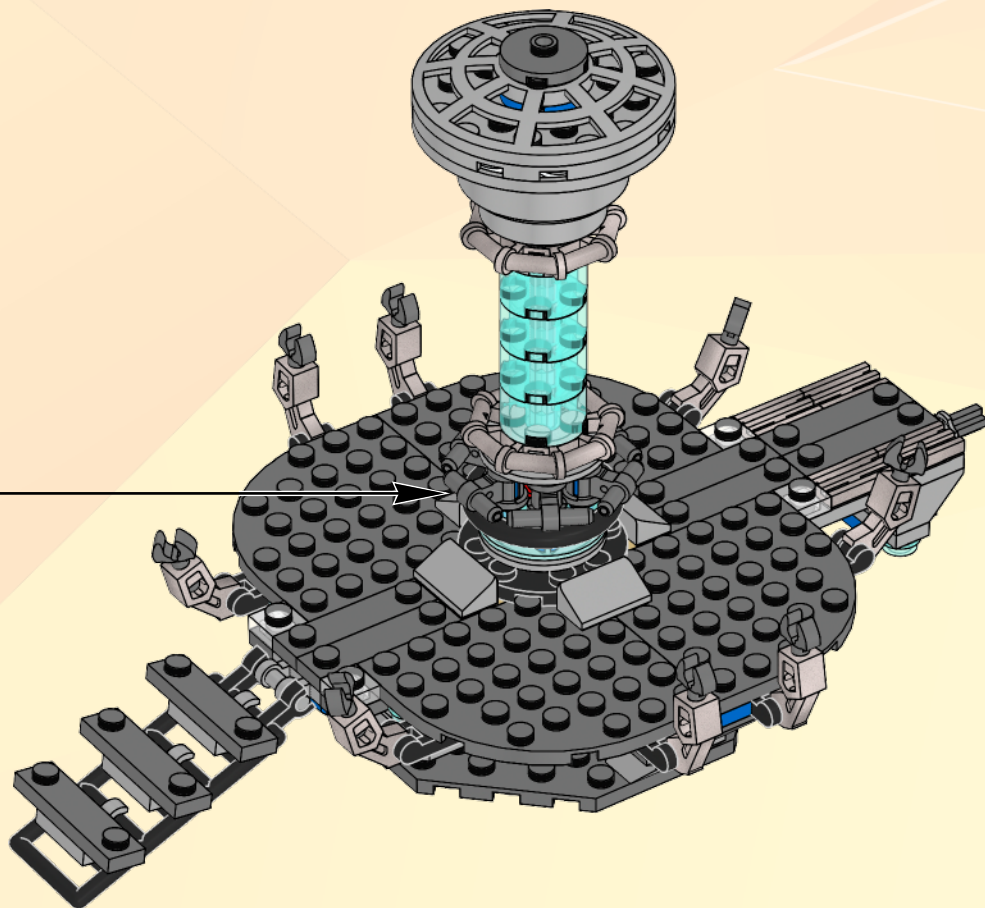

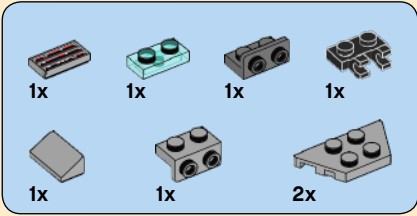

22

1

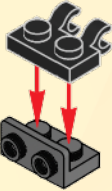

2



3

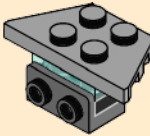

4

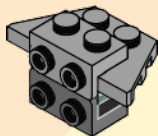

5

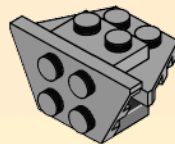

6

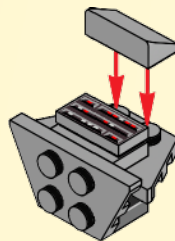

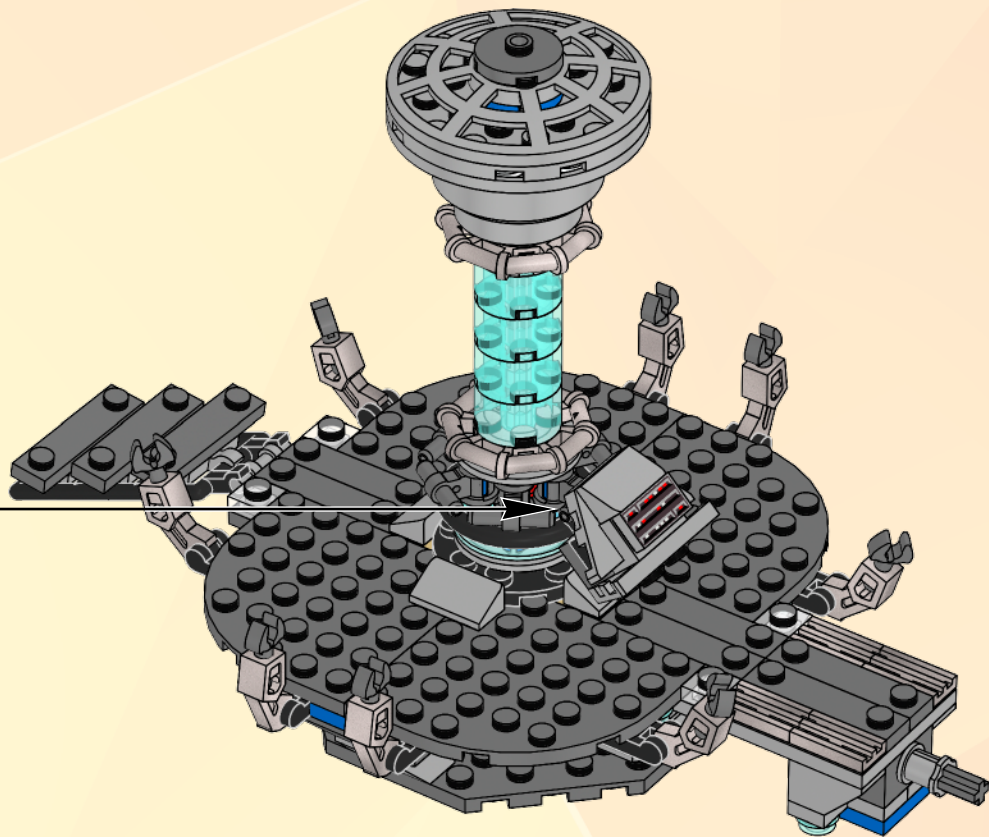



1x



1x



1x



1x



1x



1x



1x



1x

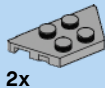

2x

23

1

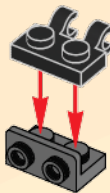

2



3

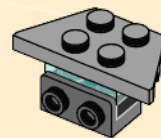

4

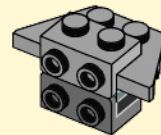

5

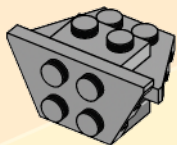

7

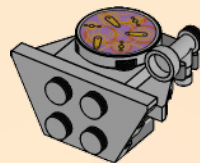

6

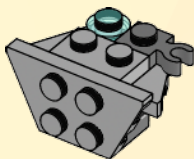

8

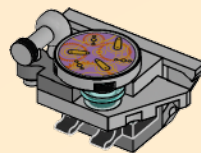
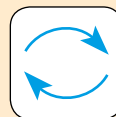

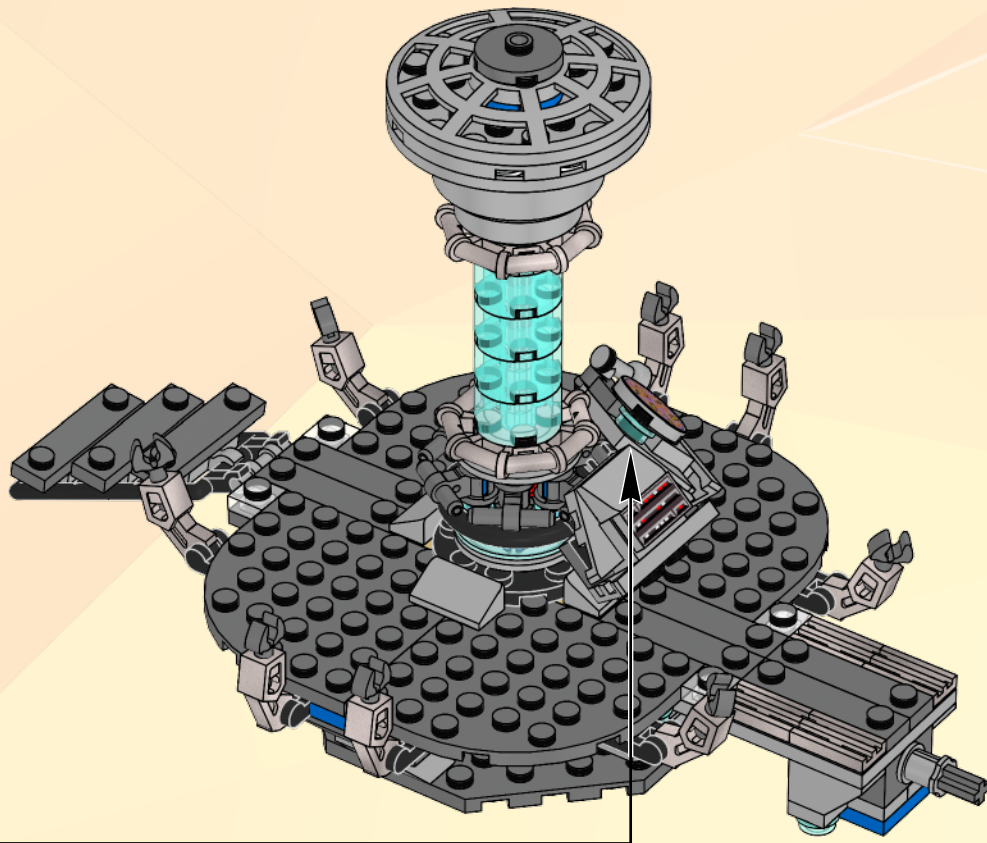

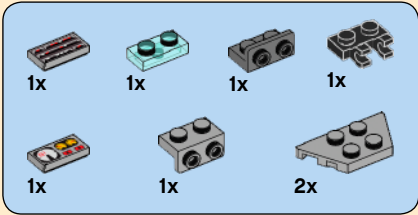

24

1

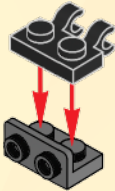

2



3

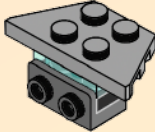

4

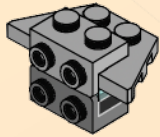

5

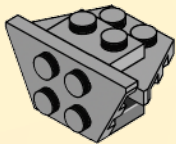

6

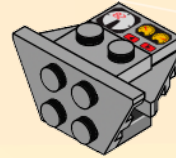

7

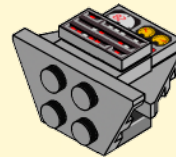

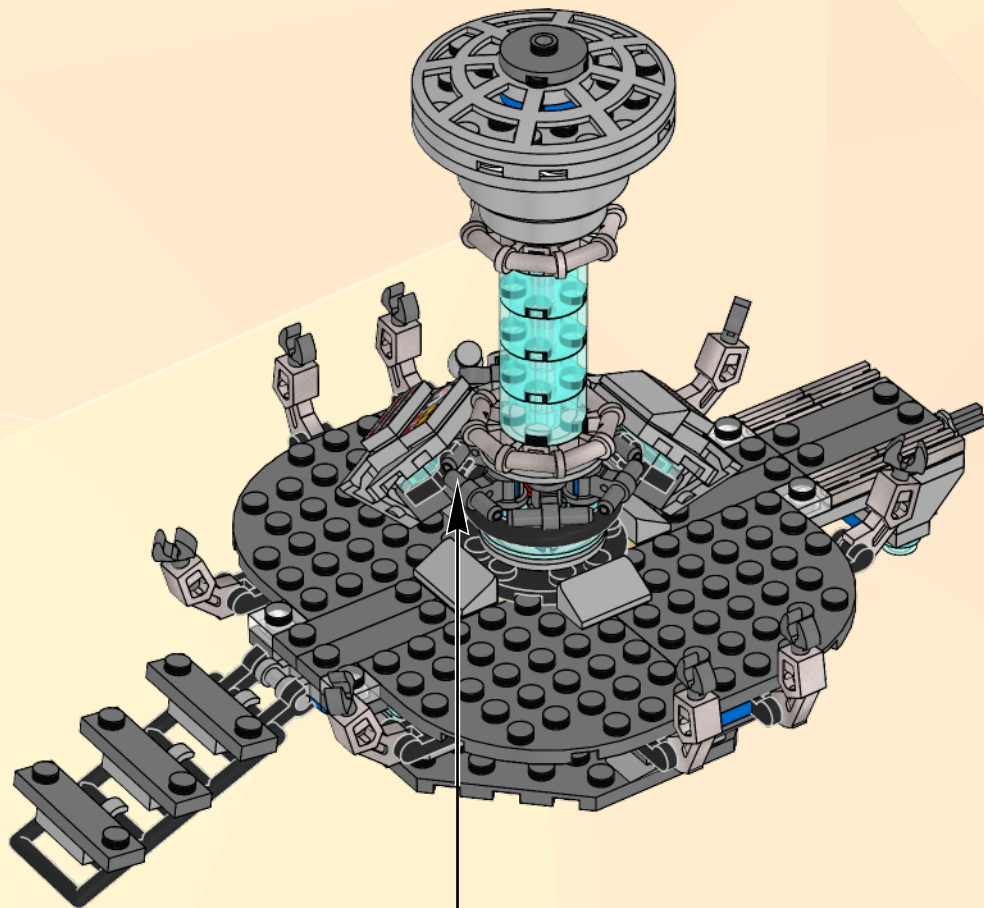

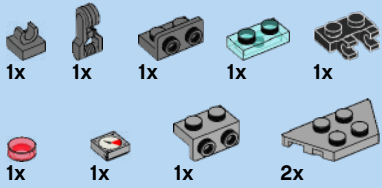

25

1

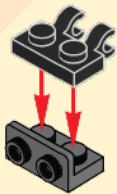

2



3

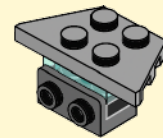

4

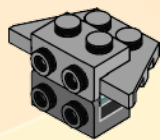

5

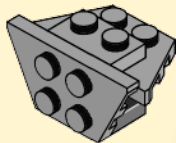

6

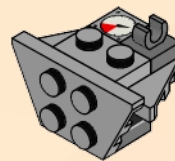

7

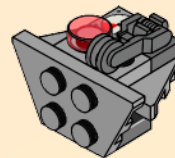

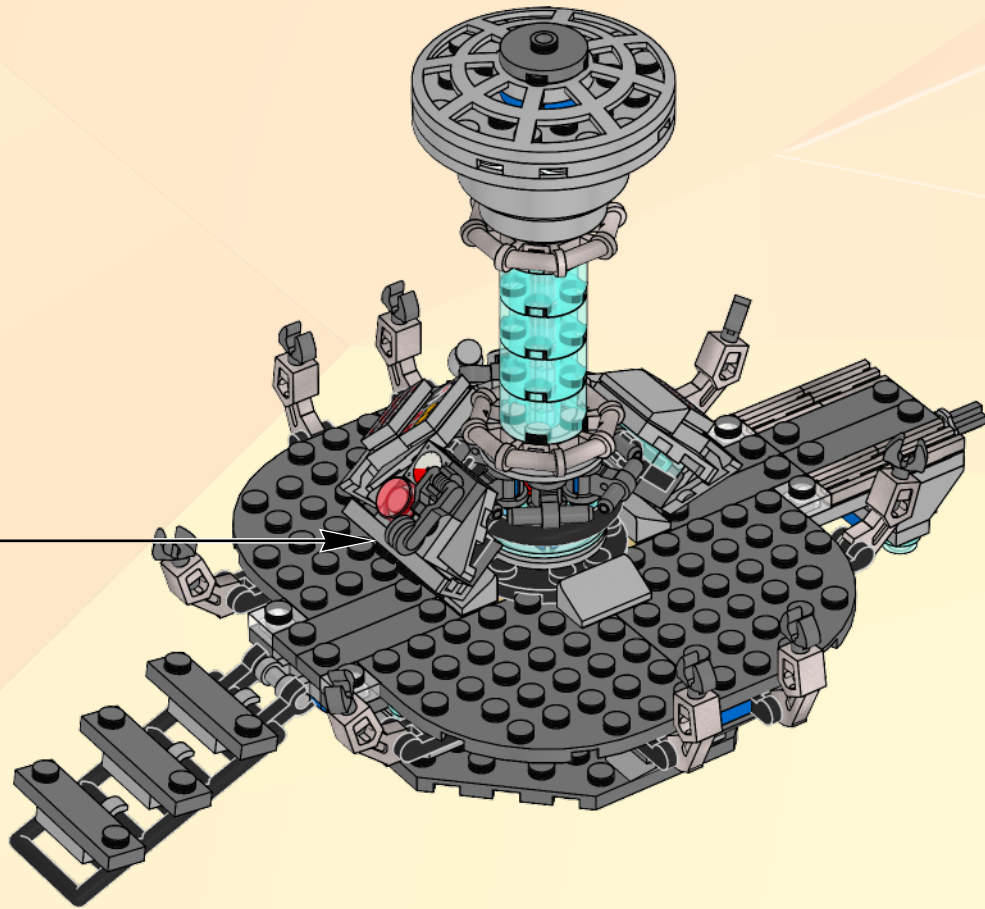

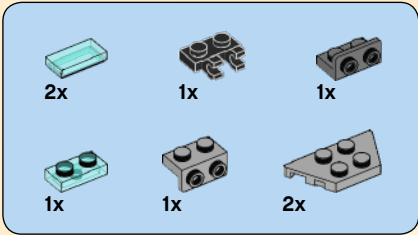

26

1

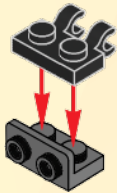

2



3

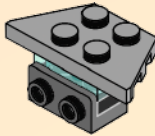

4

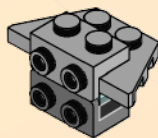

6

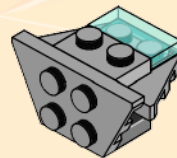

5

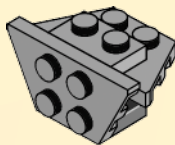

7

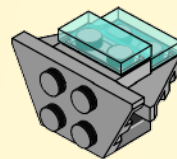

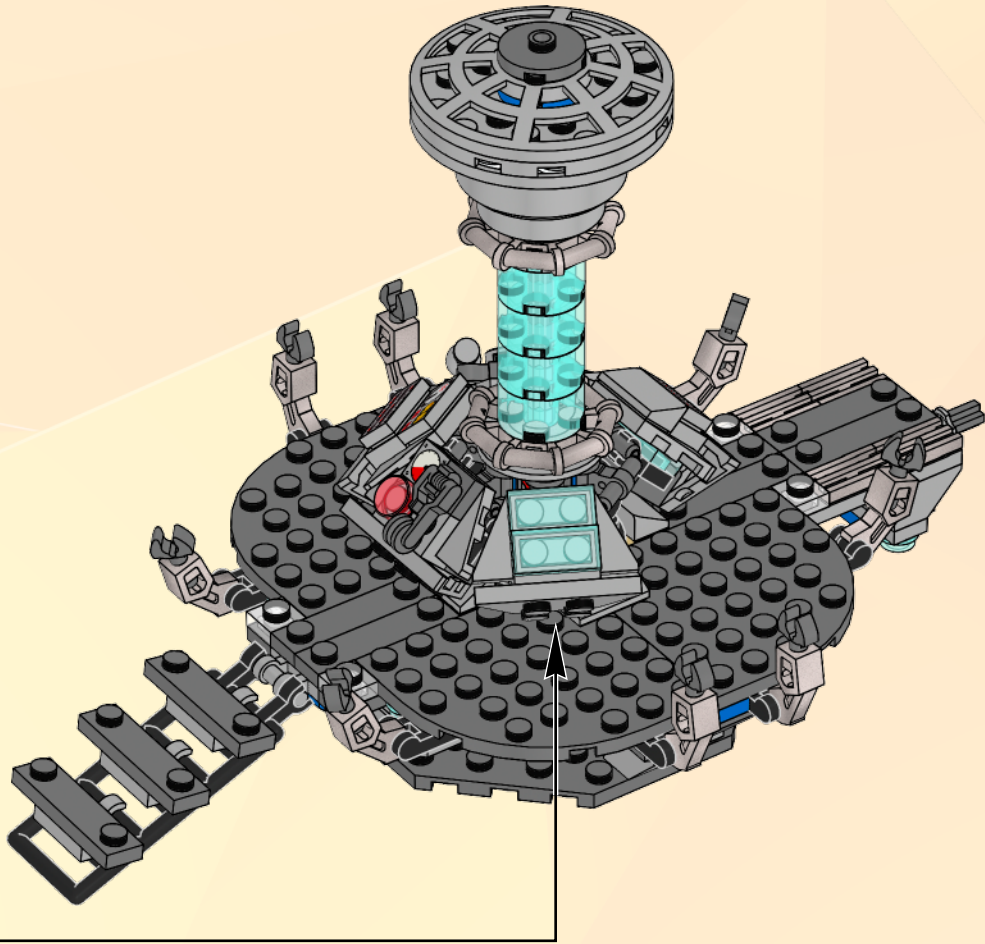



1x

1x

1x

1x

1x

1x

1x

2x

27

1

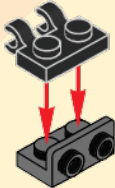

2



3

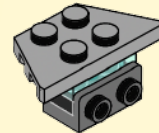

4

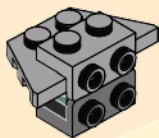

5

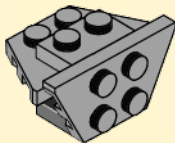

6

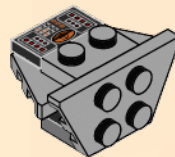

7

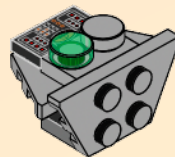

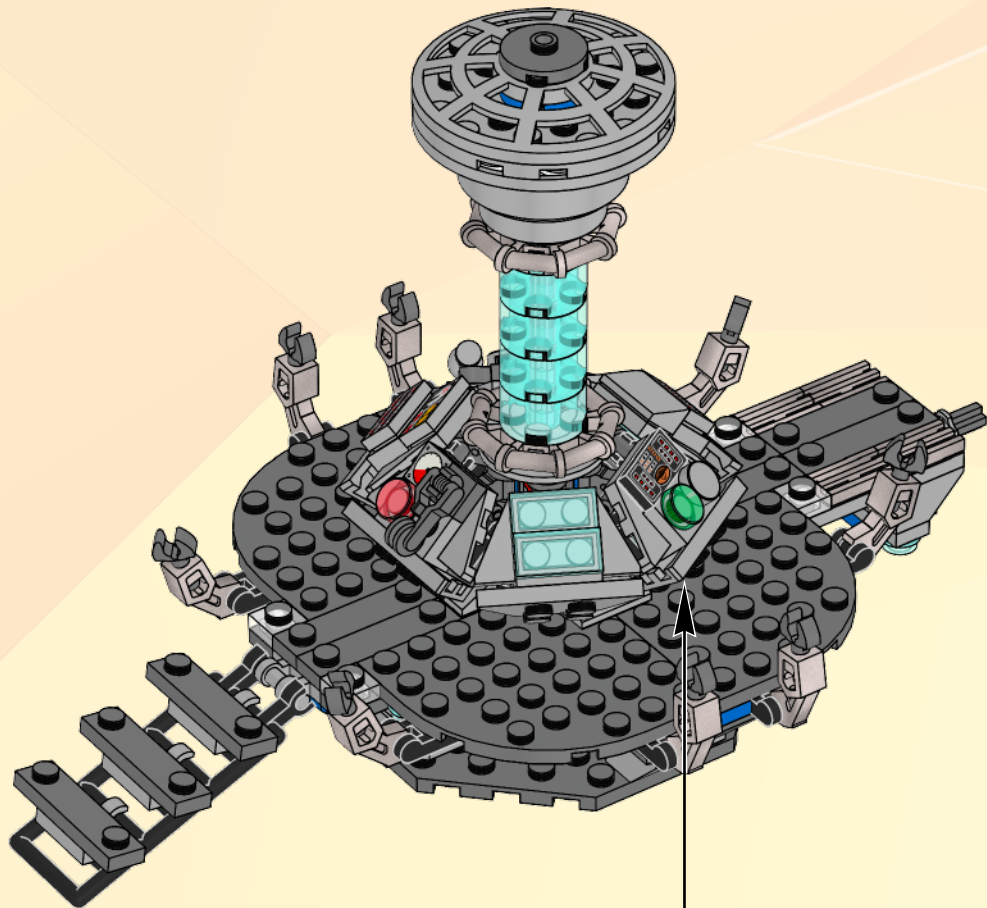

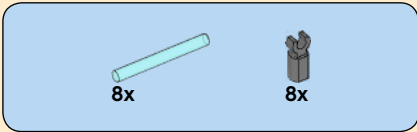

28

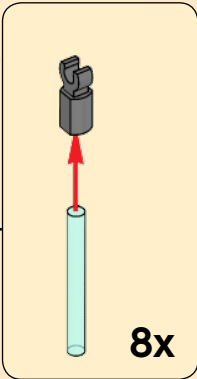
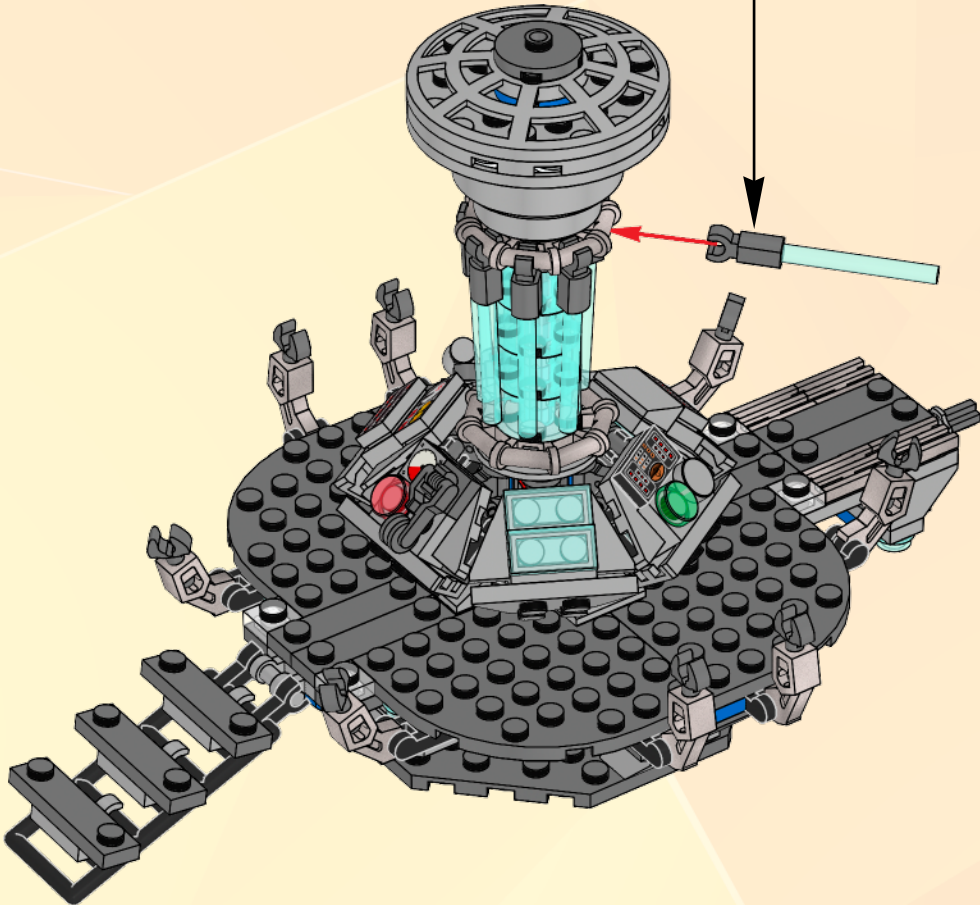

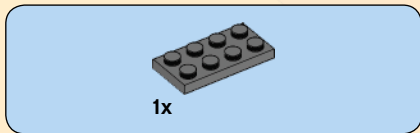
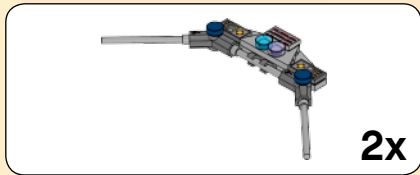

1

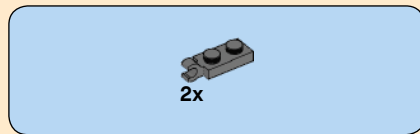
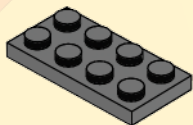

2

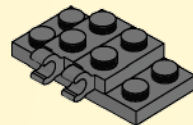

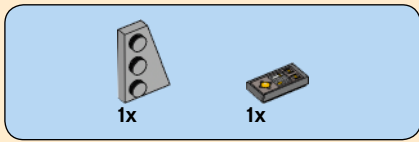

3

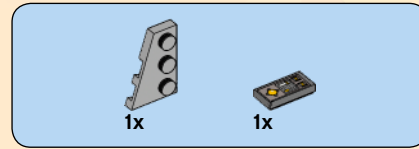
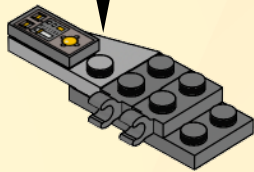
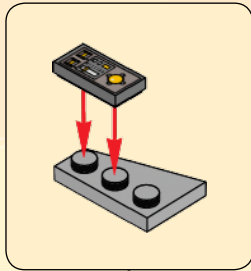

4

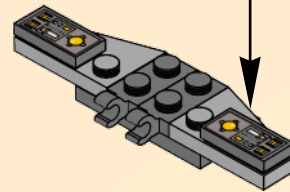
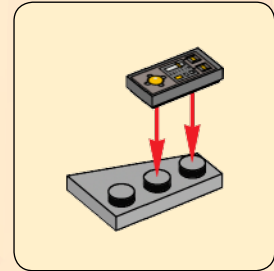



1x

5

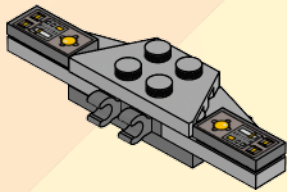

1x



1x



1x

6

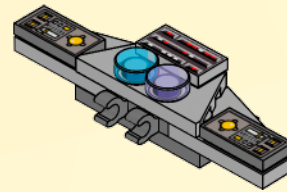

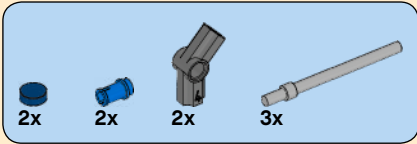
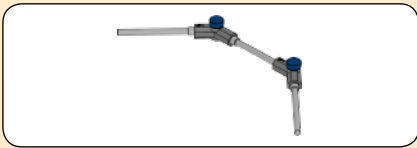

7

1

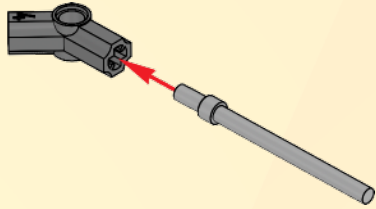

2

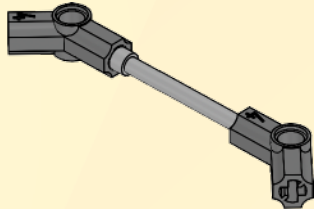

3

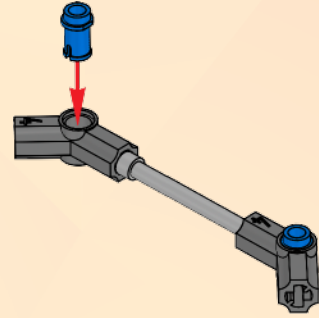

4

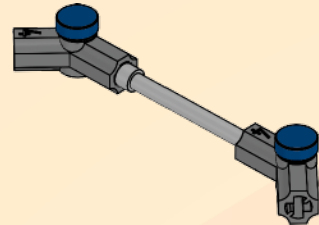

5

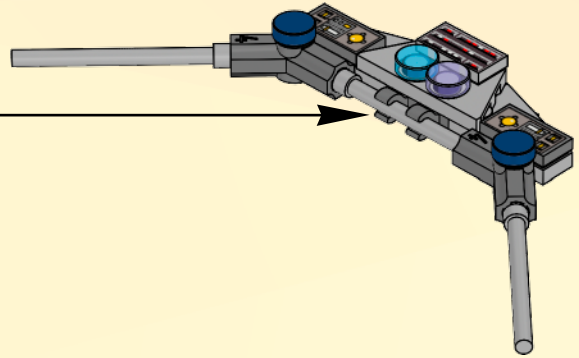
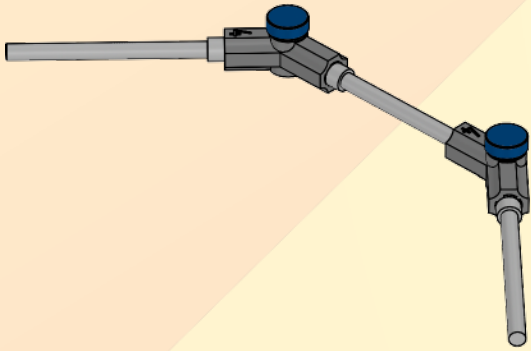

2x

29

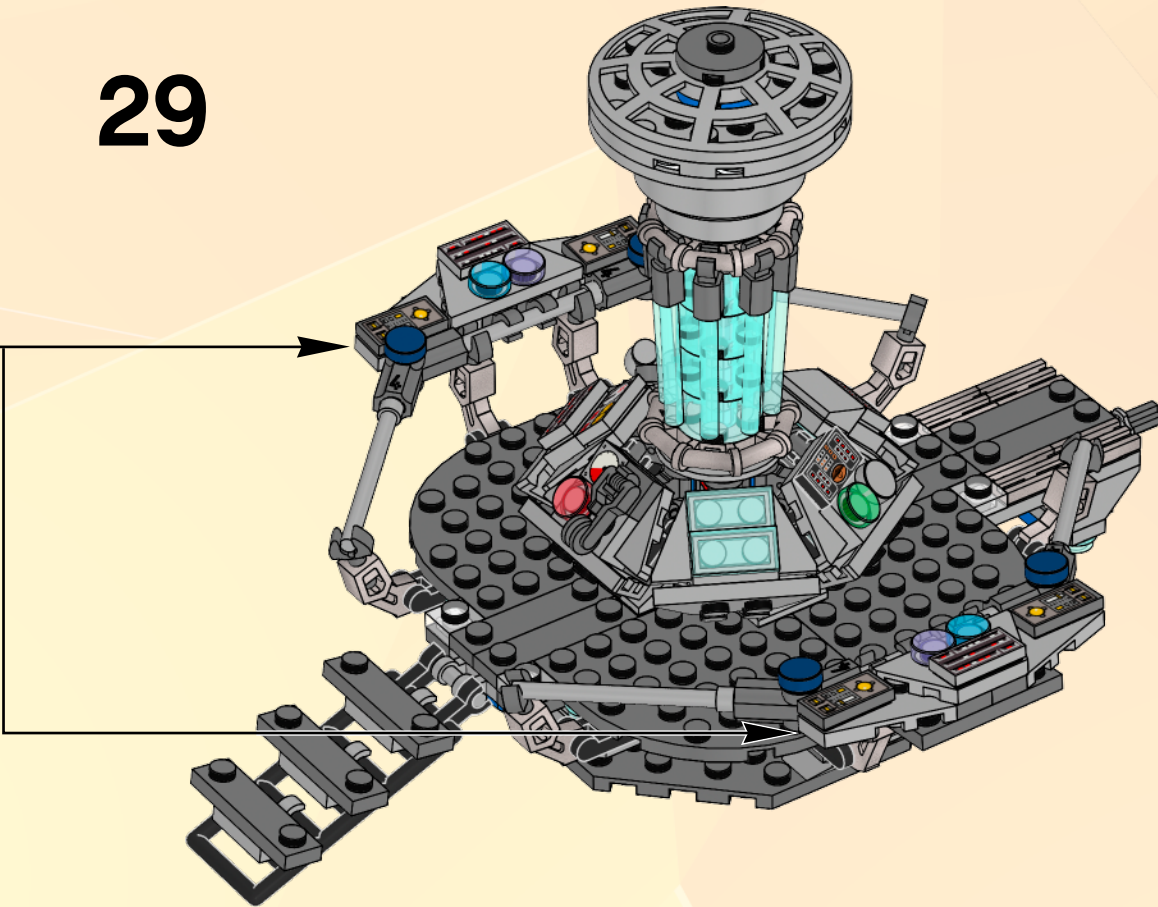



2x



2x

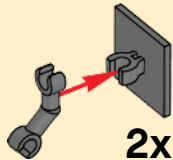

2x

30

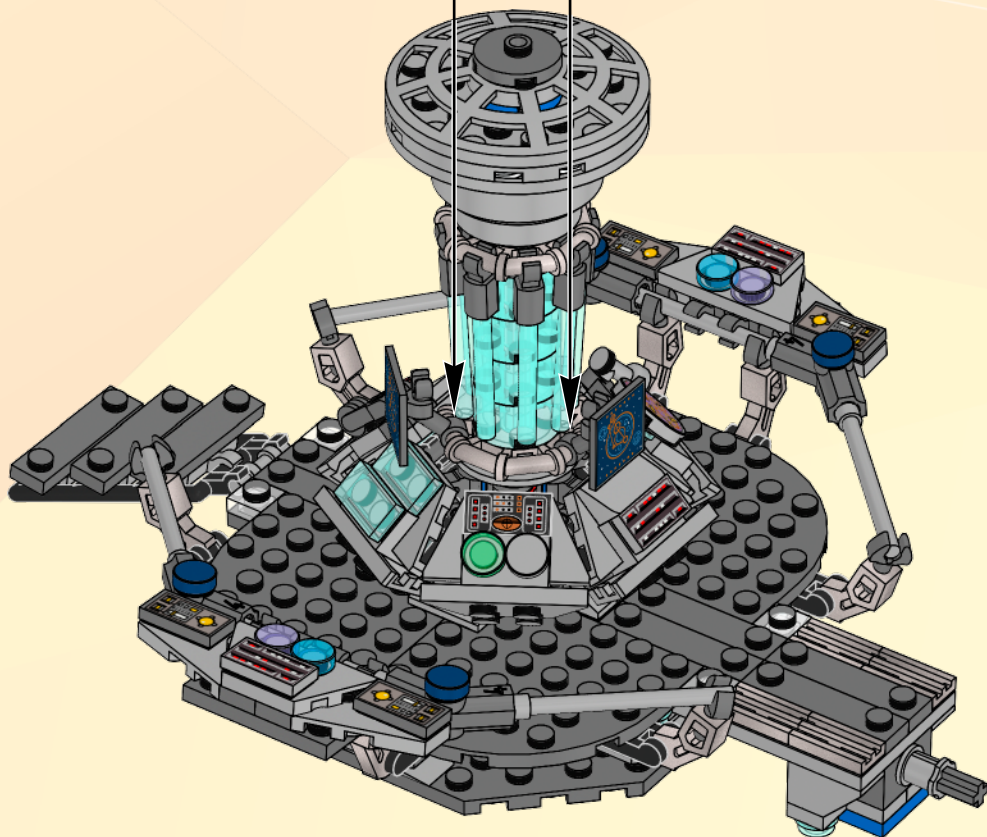

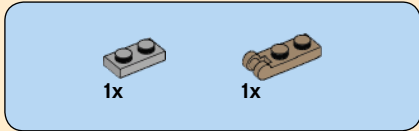

1

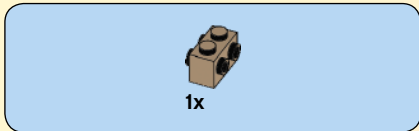
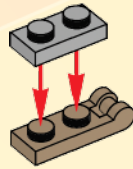

2

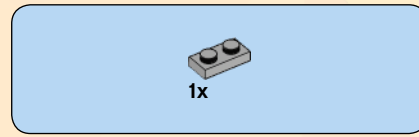
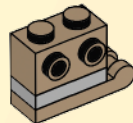

3

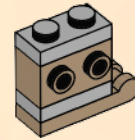

4

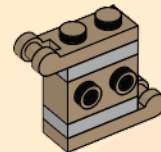



1x

5

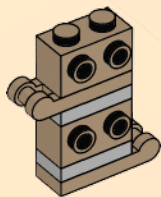

1x

6

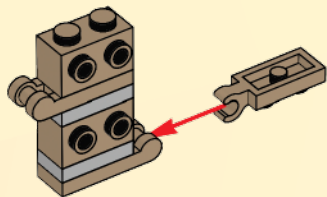

1x



1x

7

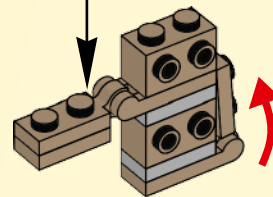
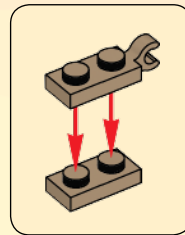

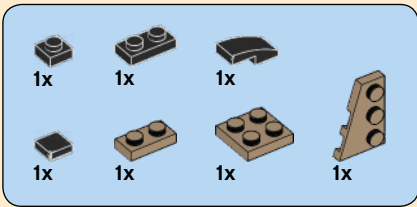

8

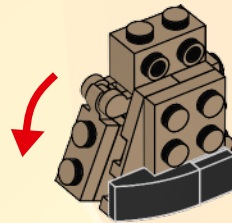



1x



1x

9

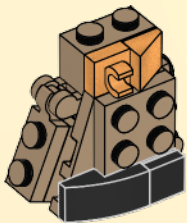

1x



1x

10

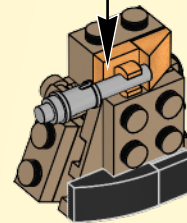
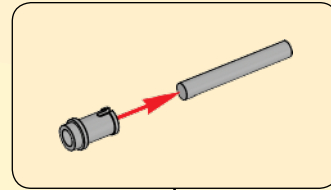

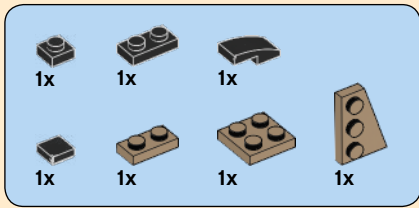

11

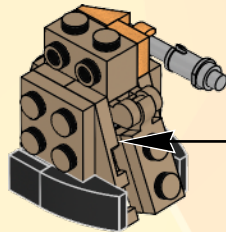
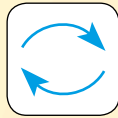
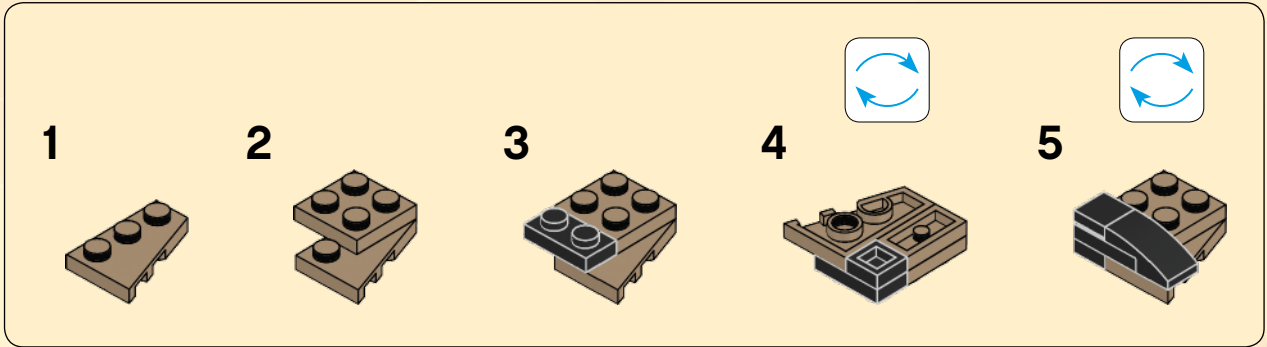



1x



1x



1x

12

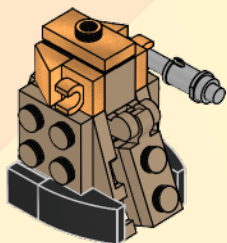

1x



1x

13

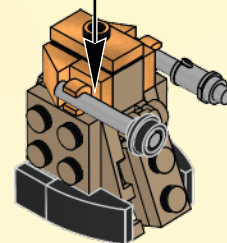
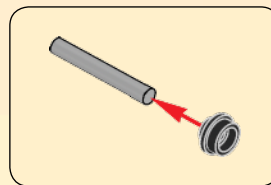



1x

14

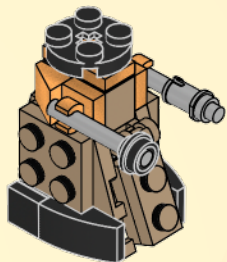

1x

15

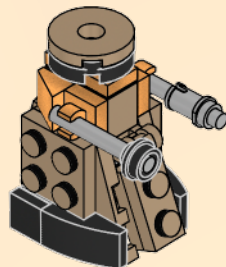



1x



1x



1x

16

1

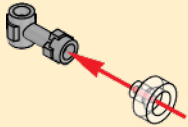

2

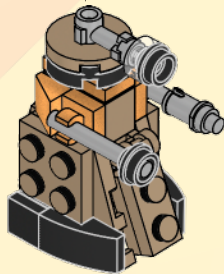
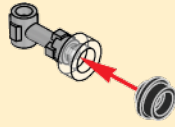

1x

17

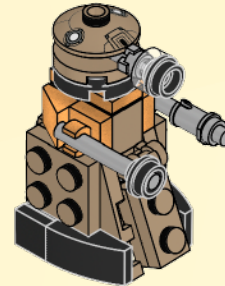

2x

31

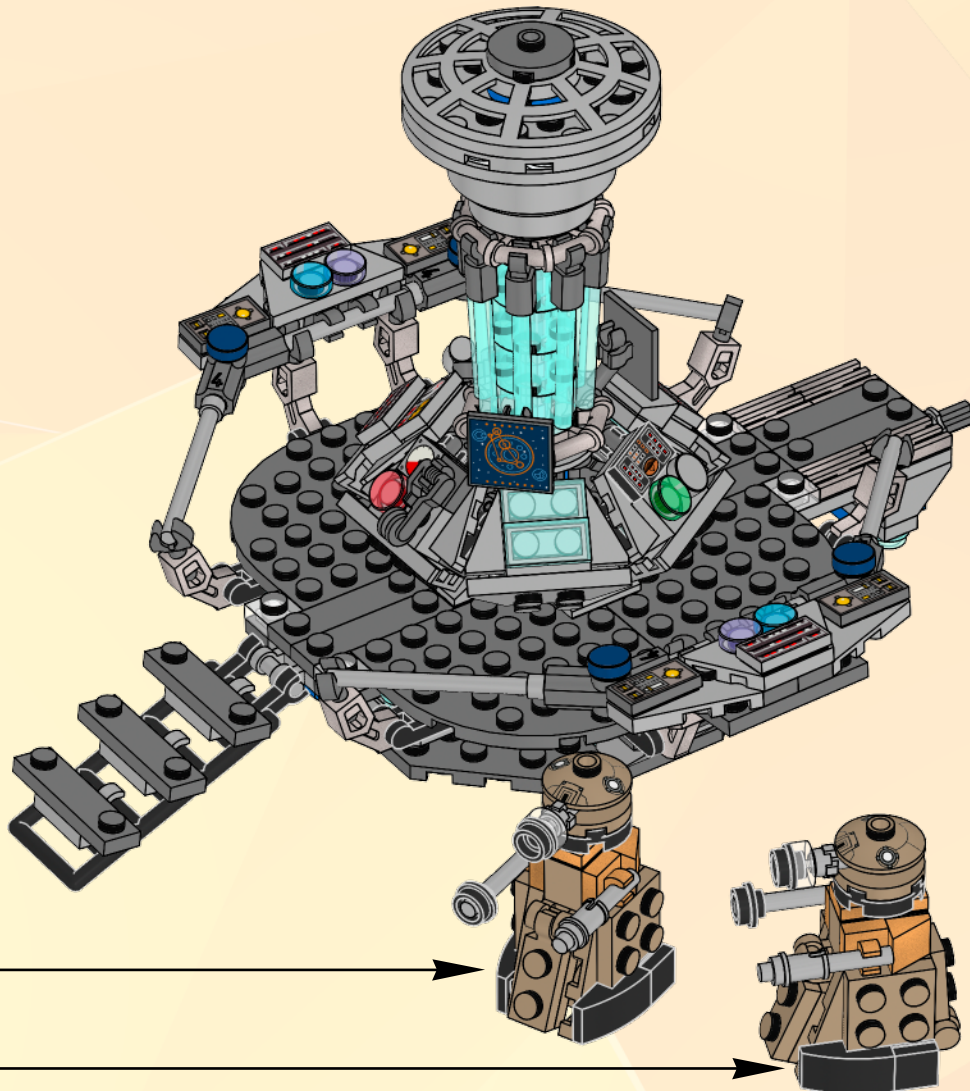

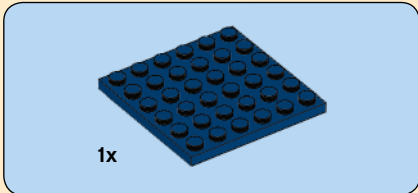

1x

1

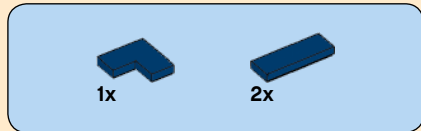
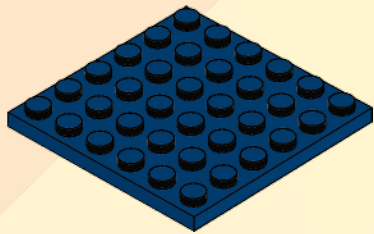

2

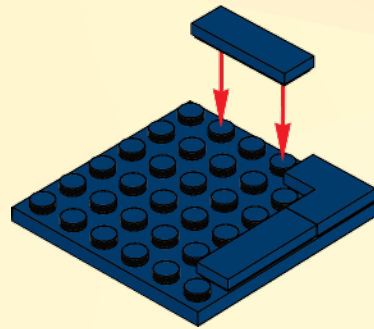

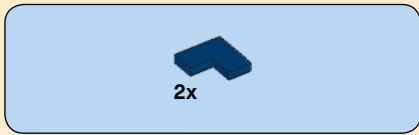

3

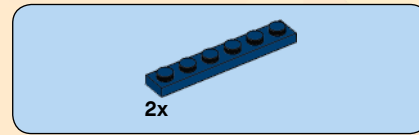
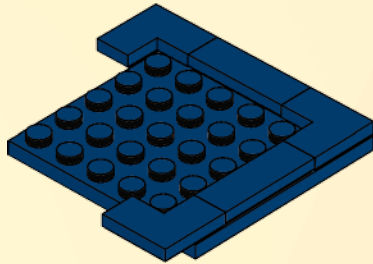

4

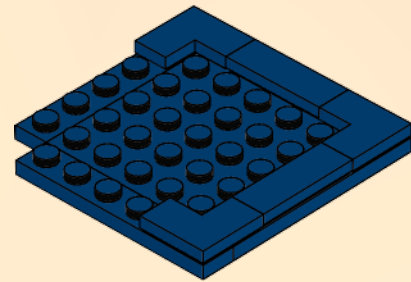

TARDIS stands for Time and Relative Dimension in Space and is a Type 40 model.

TARDIS est l'acronyme de Temps À Relativité Dimensionnelle Inter Spatiale et est un modèle de type 40.

TARDIS son las siglas en inglés de «Time and Relative Dimension in Space»; la nave es de tipo 40.



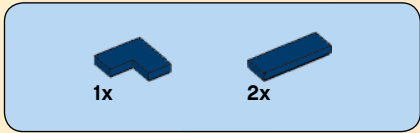

5

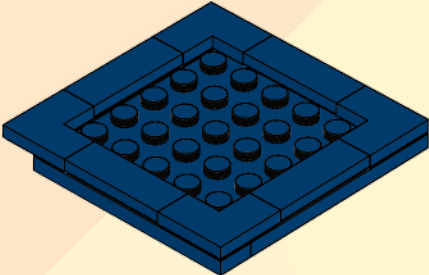

6

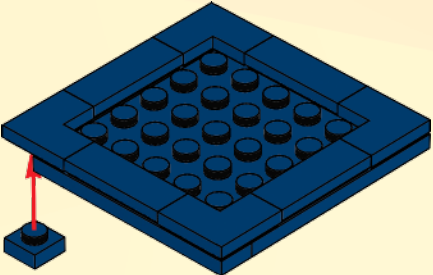

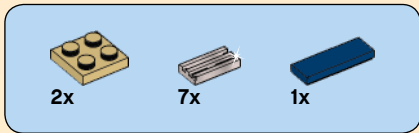

7

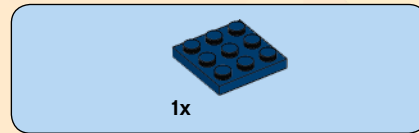
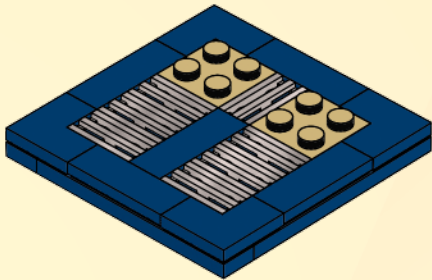

8

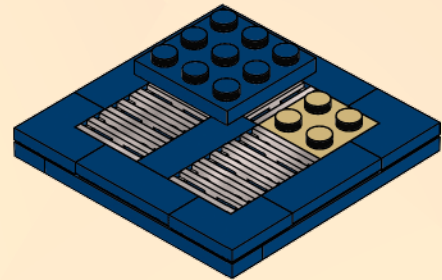

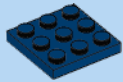

1x

9

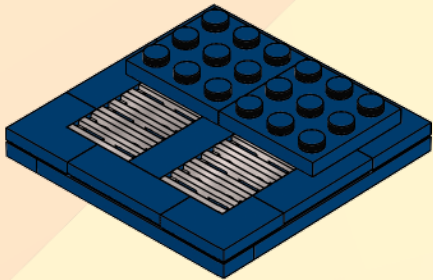

1x



1x

10

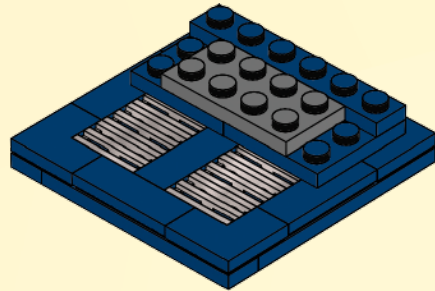

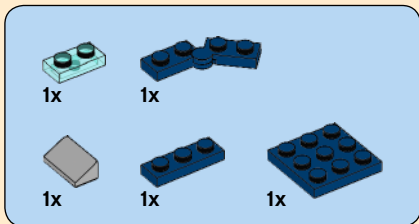

11

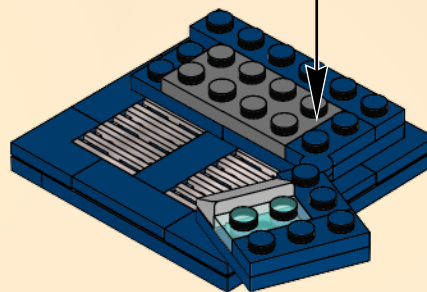
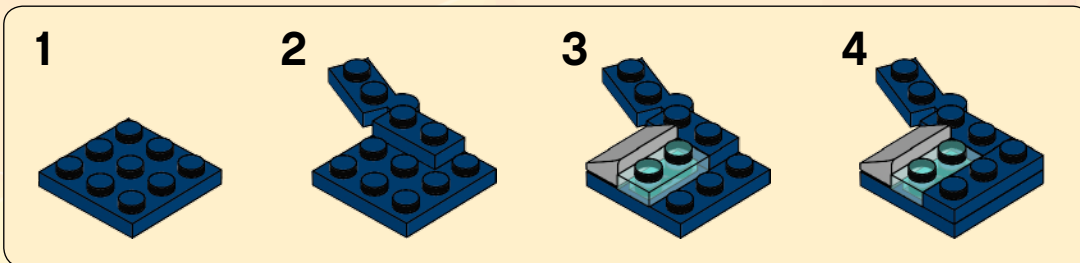

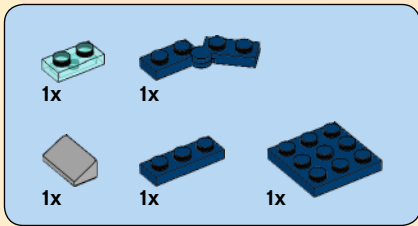

12

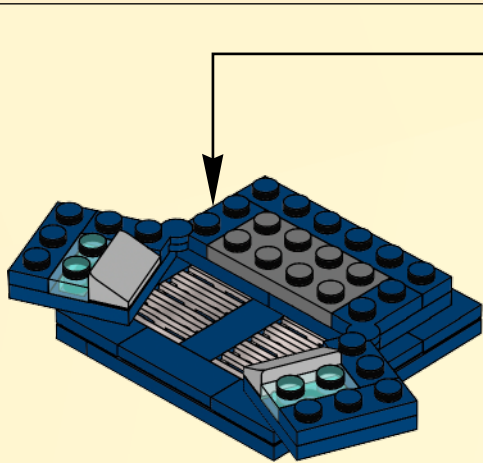
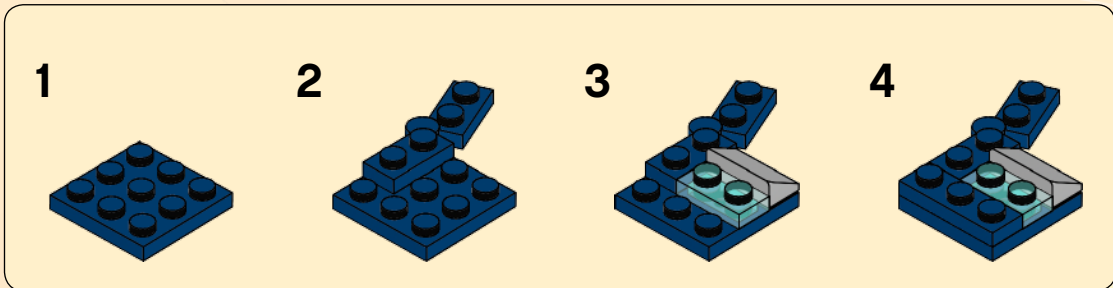

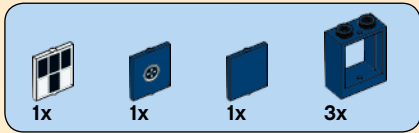

13

1

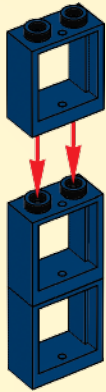

2

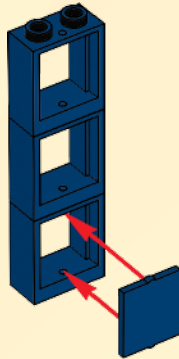

3

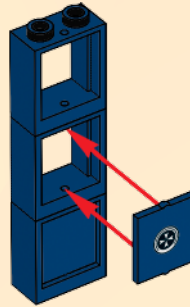

4

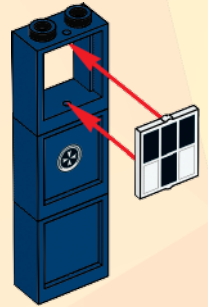

5

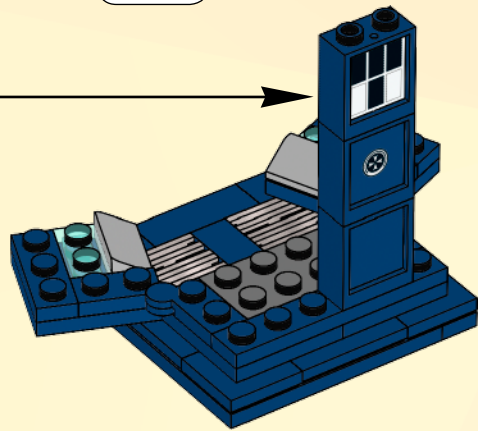
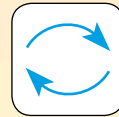

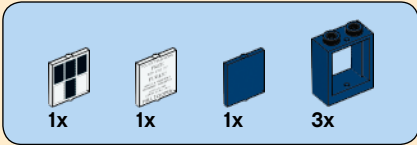

14

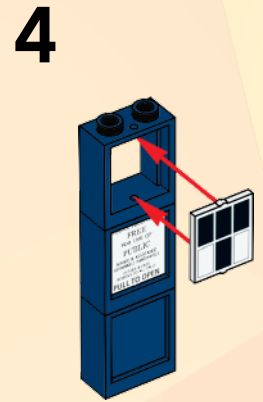
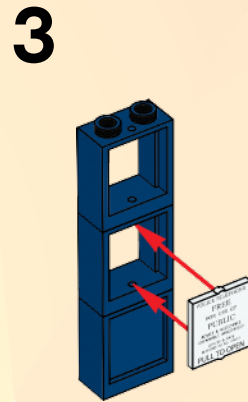
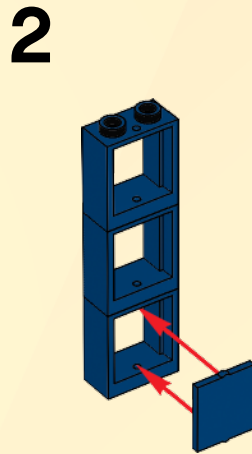
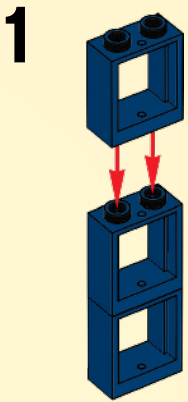

5

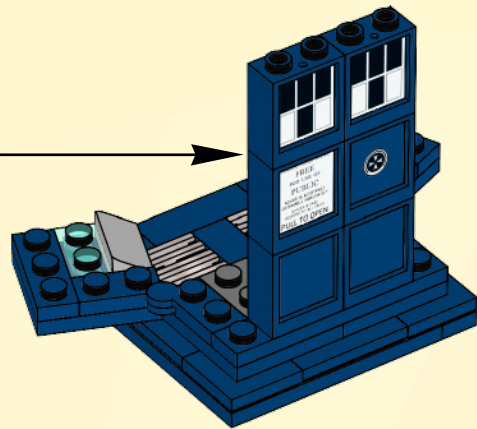



4x



2x

15

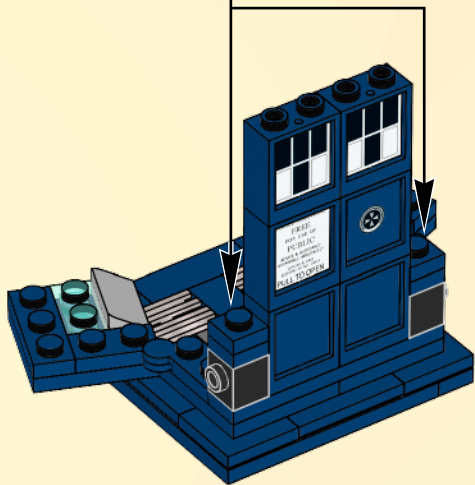
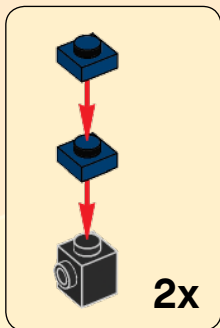

4x



2x

16

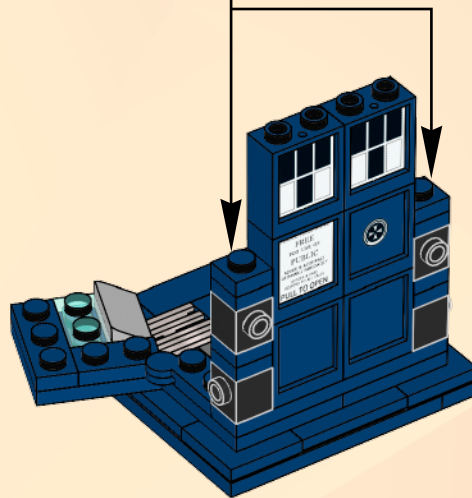
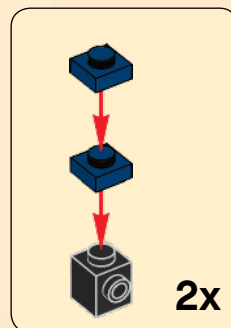



4x



2x

17

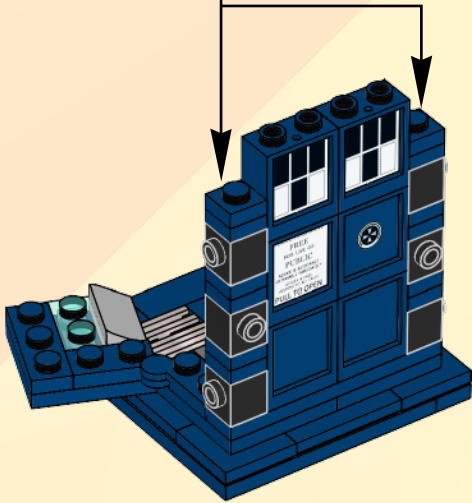
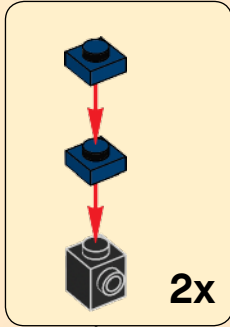

2x

18

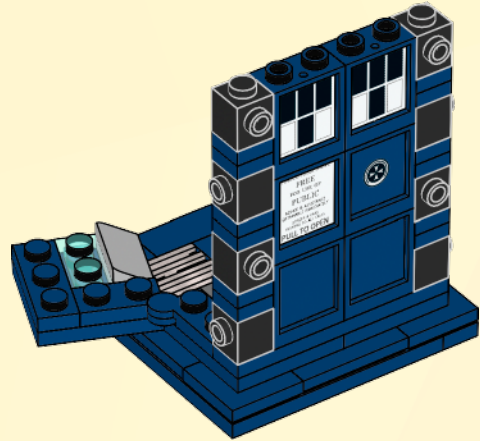

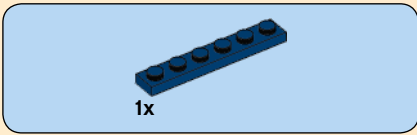

19

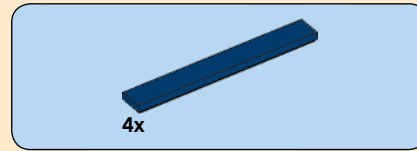
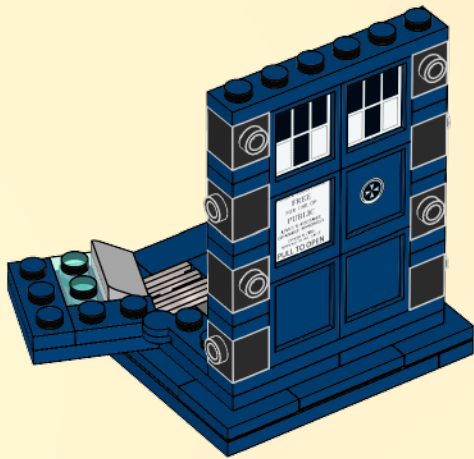

20

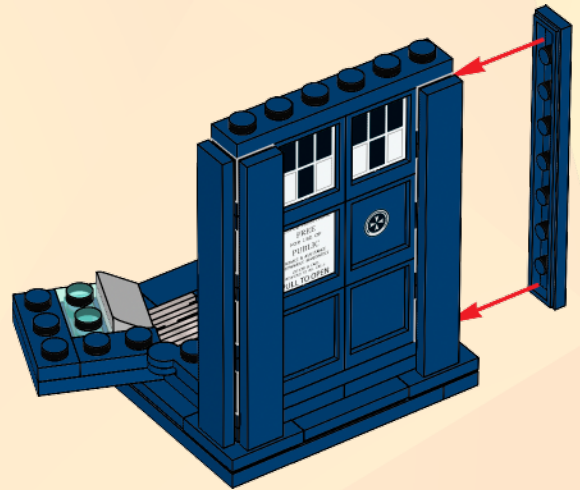

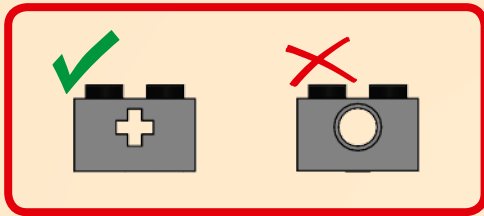
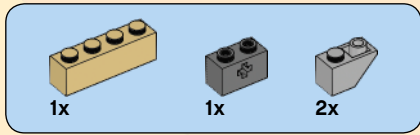

21

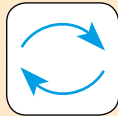



2x

22

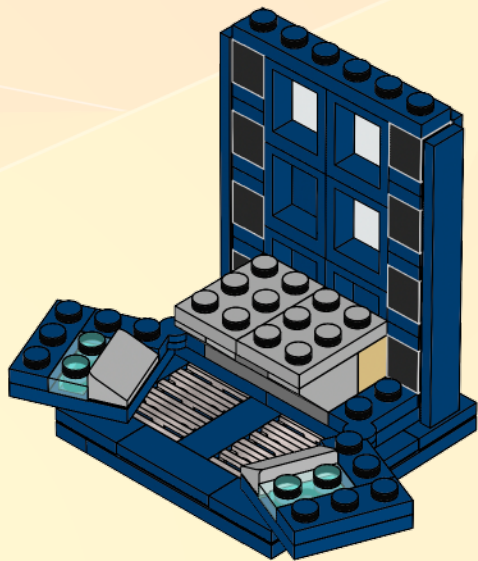

2x



2x

23

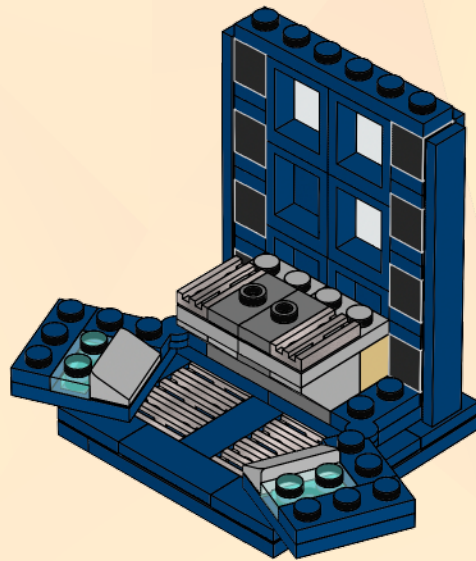



2x



2x



4x



6x

24

1

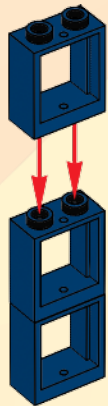

2

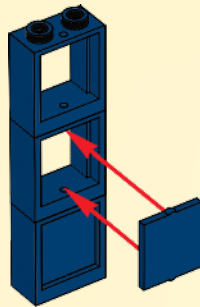

3

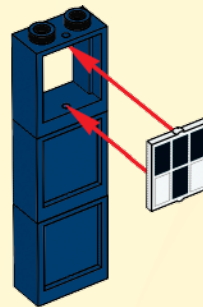

4



2x

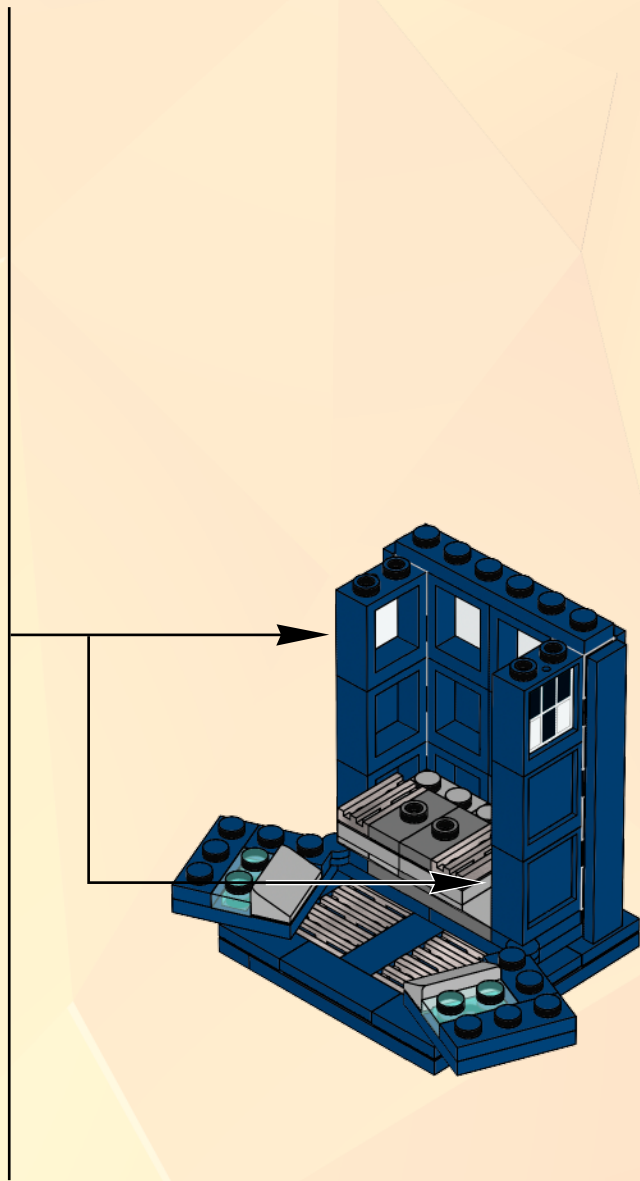



2x



2x



4x



6x

25

1

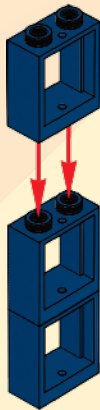

2

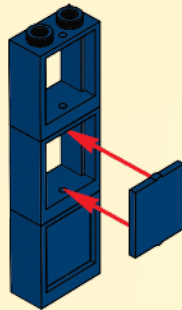

3

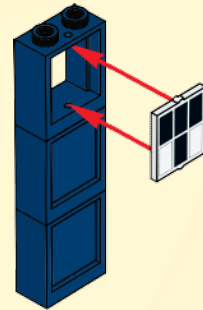

4



2x

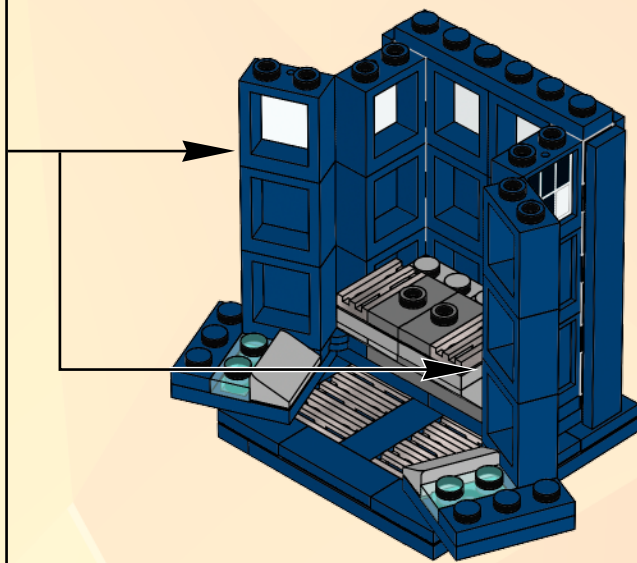



2x

26

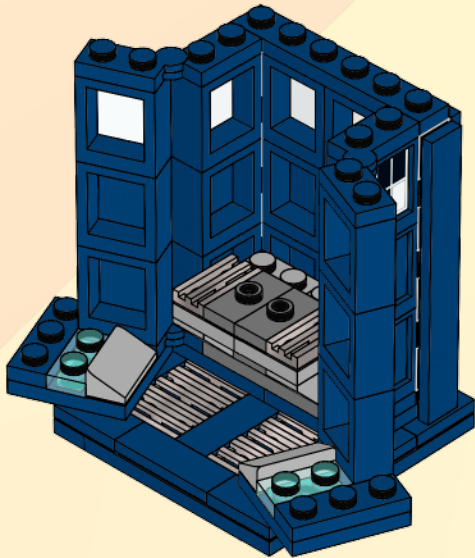

2x



2x



2x

27

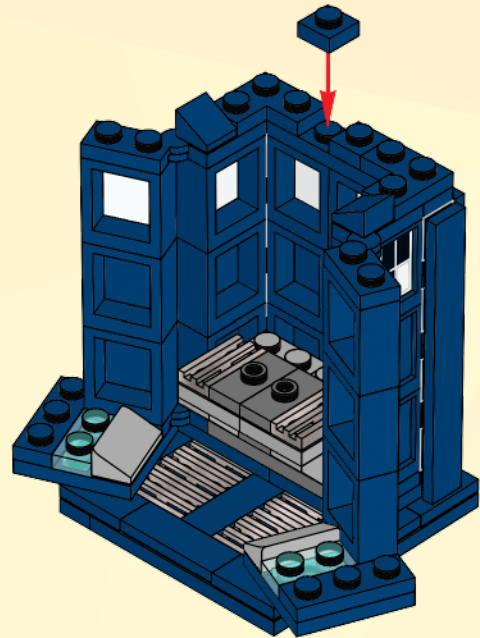



28

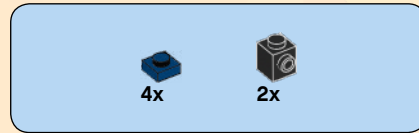
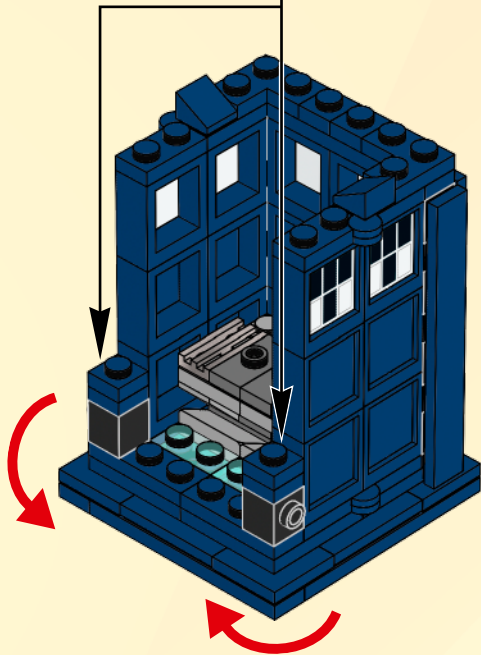
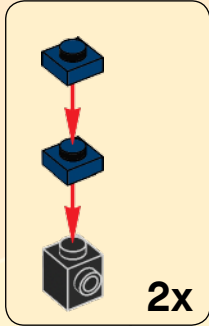

29

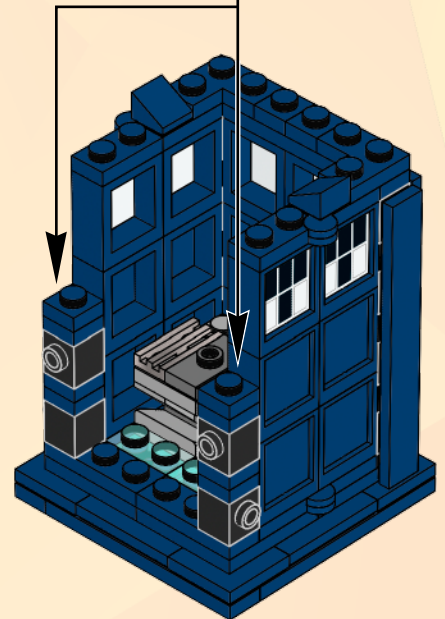
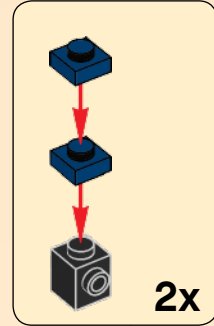



4x



2x

30

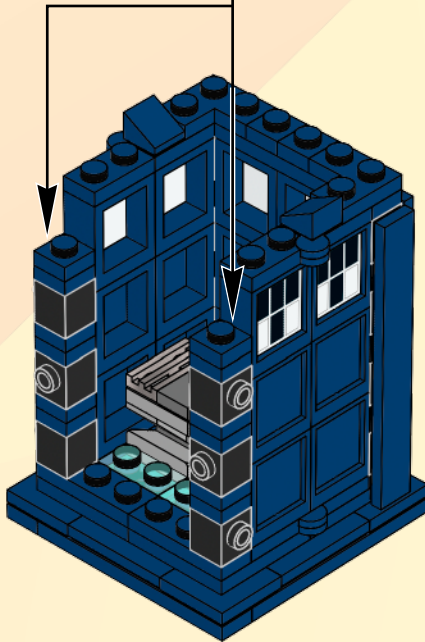
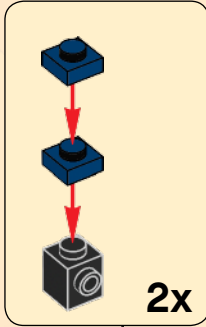

2x

31

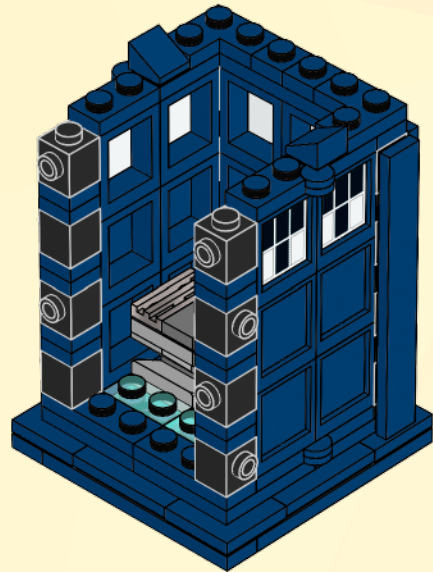

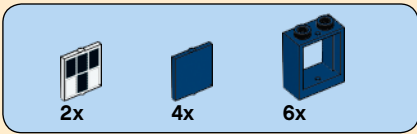

32

1

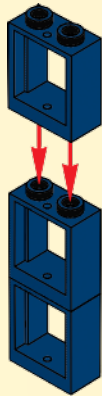

2

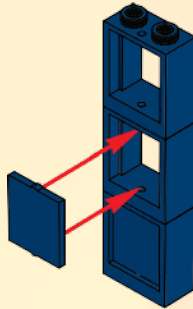

3

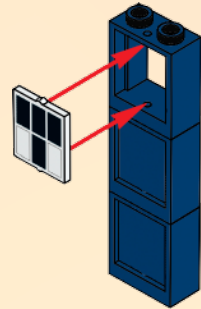

4



2x

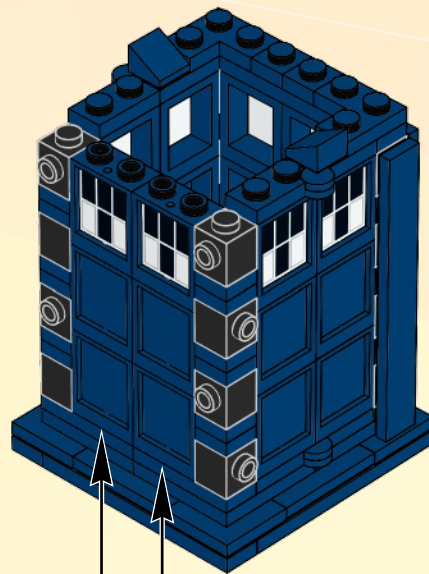

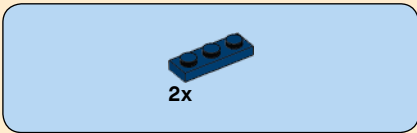

33

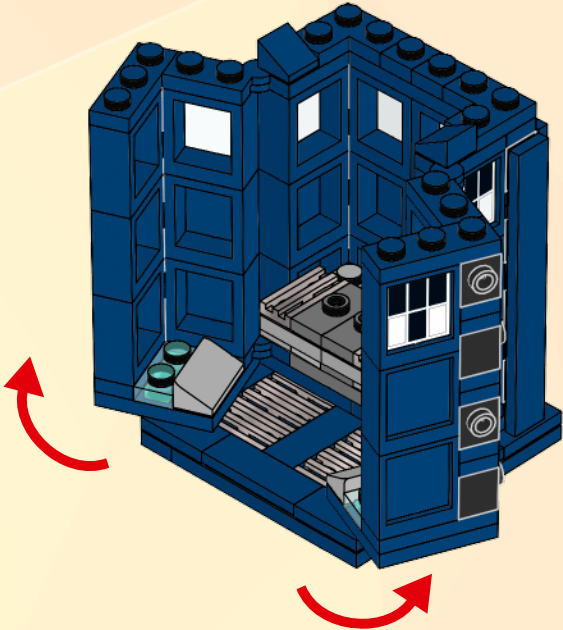

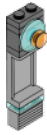

2x

2x

2x

6x

2x

2x

2x

2x

2x

34

1

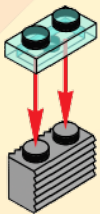

2

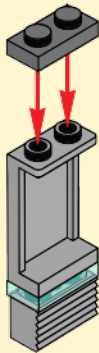

3

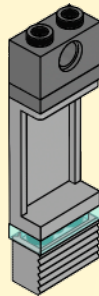

4

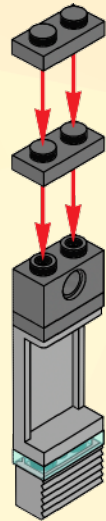

5

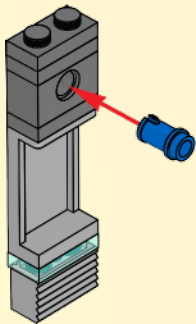

6

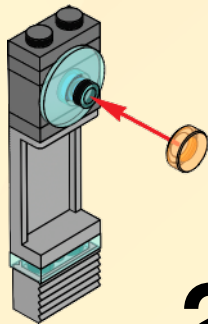

2x

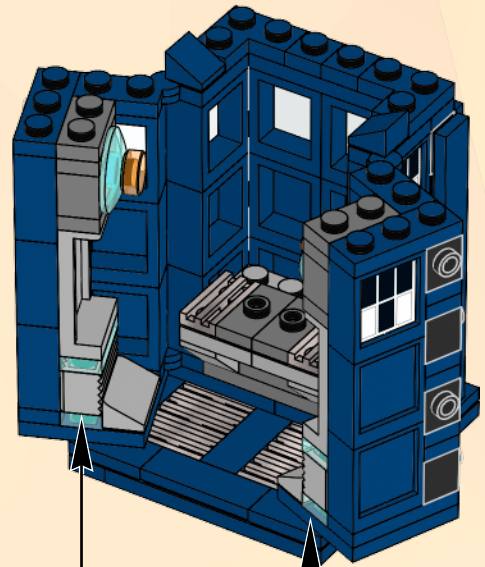



2x

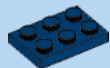

2x

35

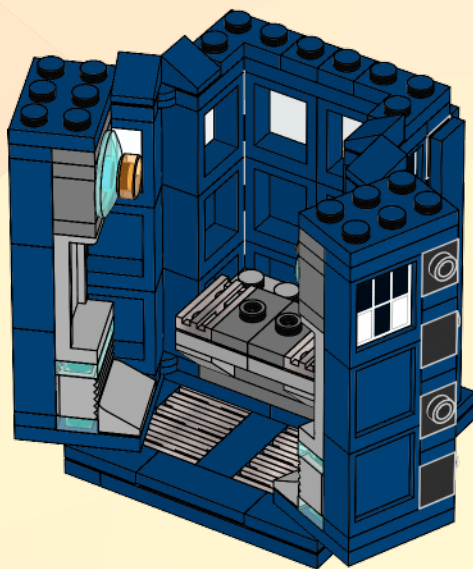

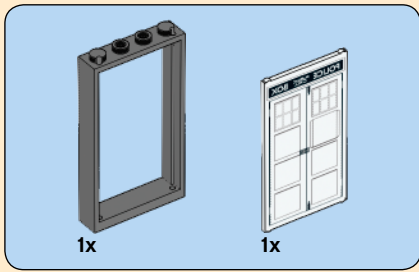

36

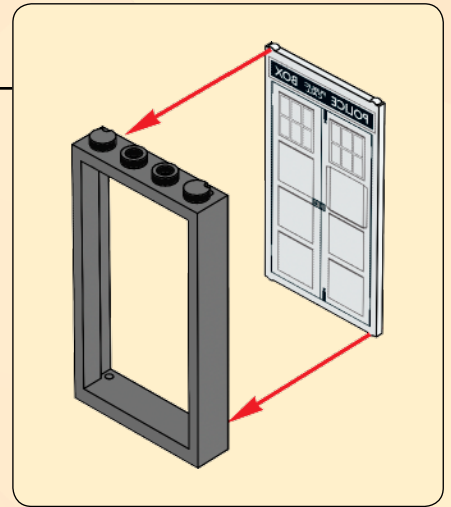
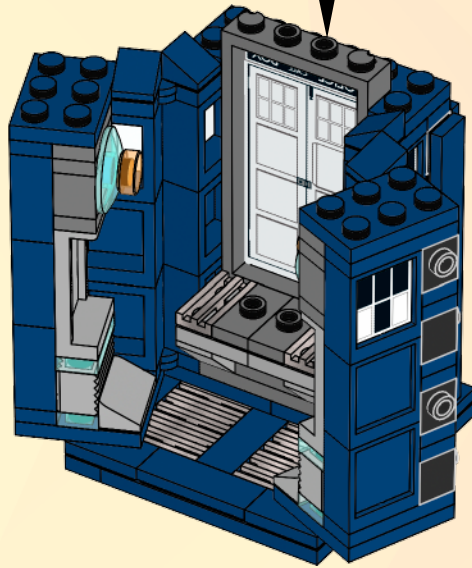

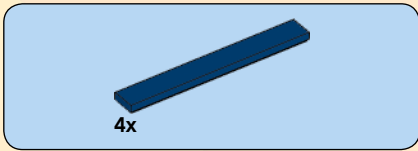

37

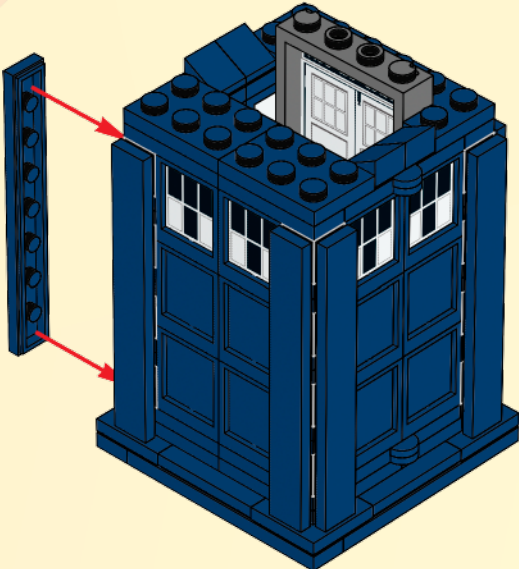



38

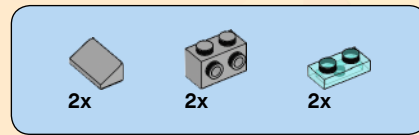
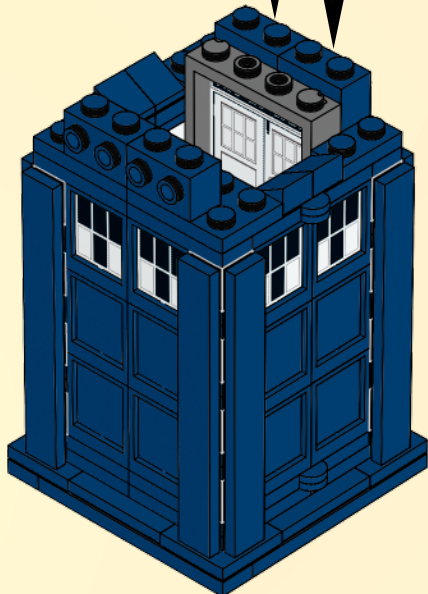
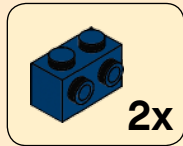

39

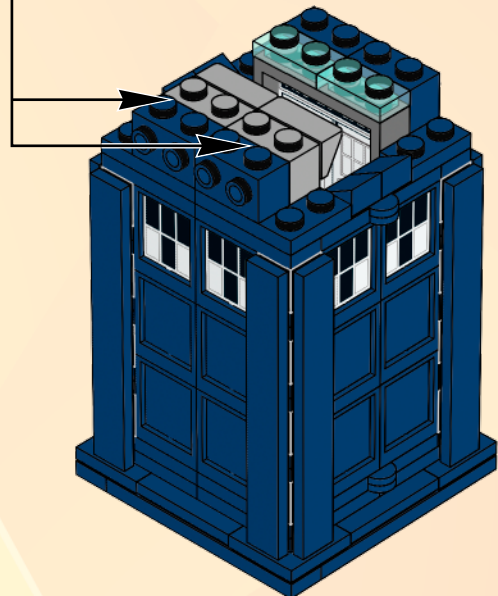
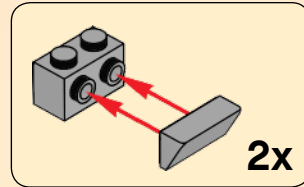



4x



4x

40

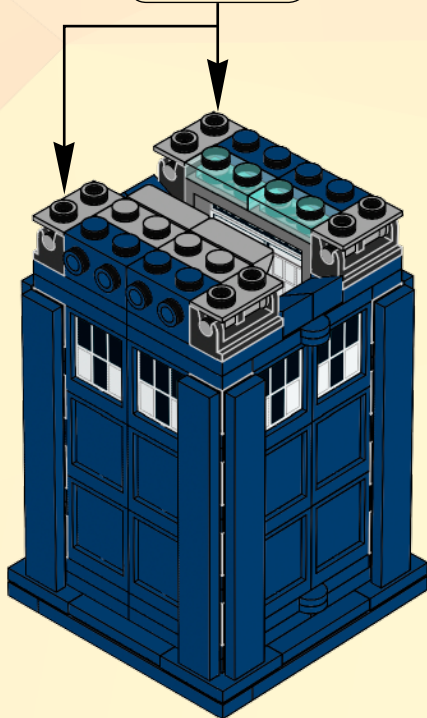
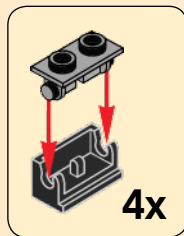



41

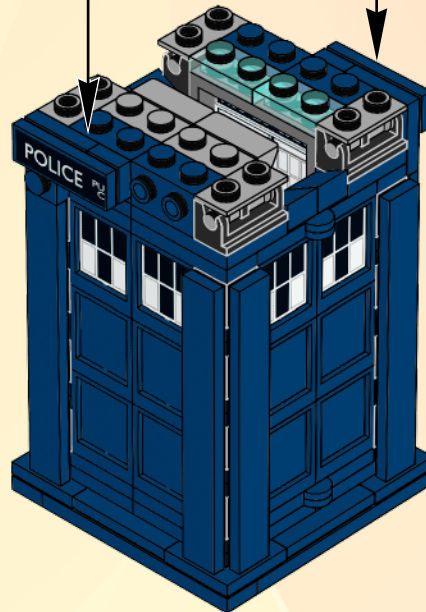
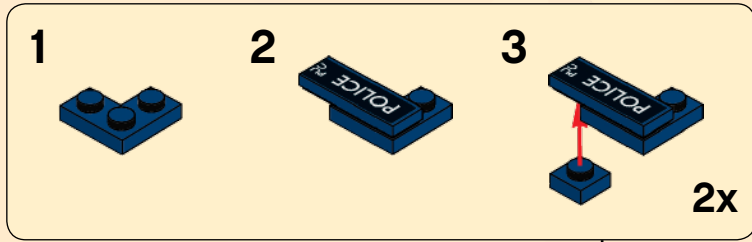



42

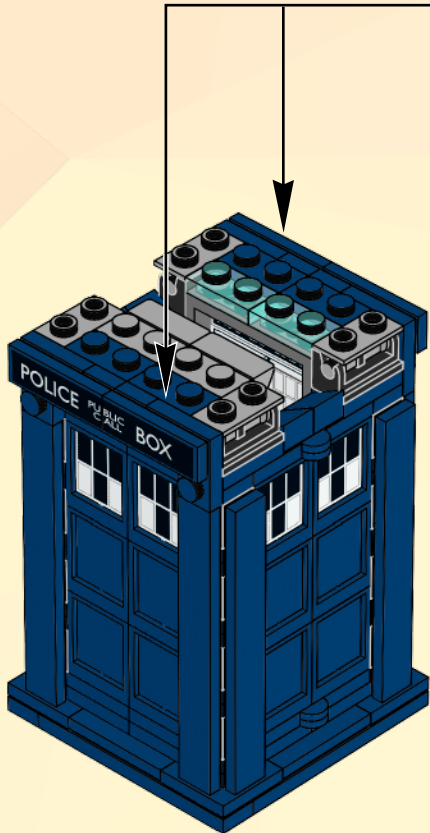
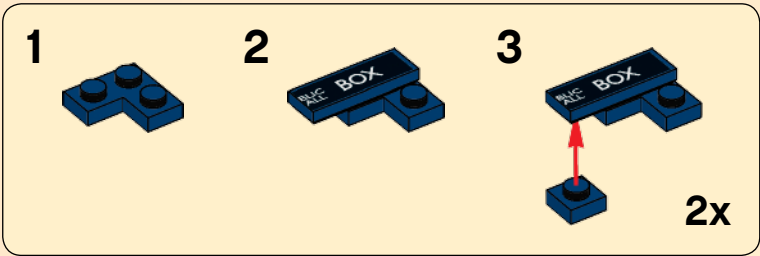

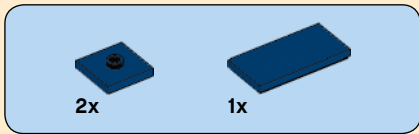

43

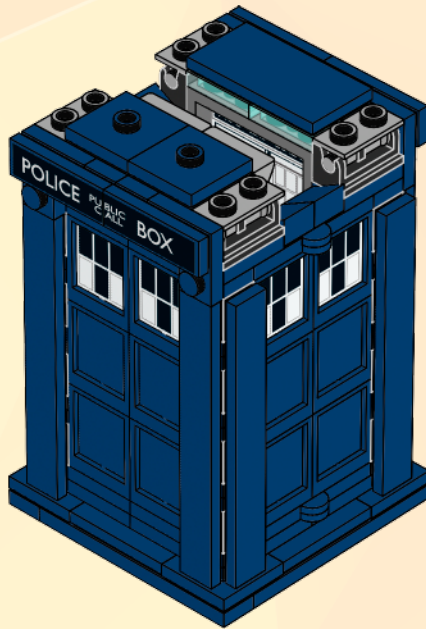



44

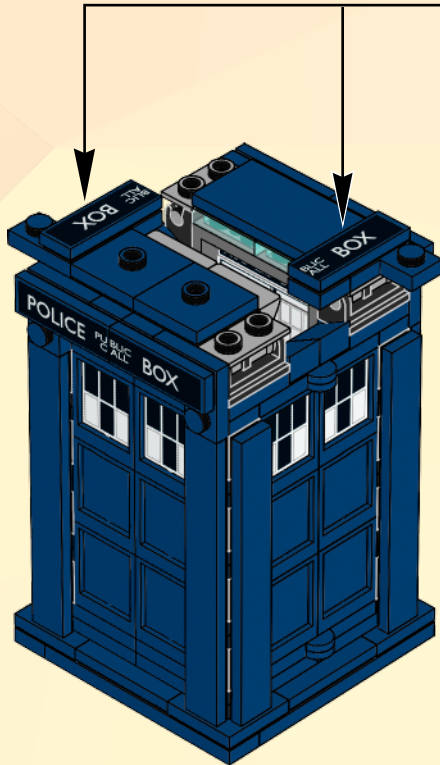
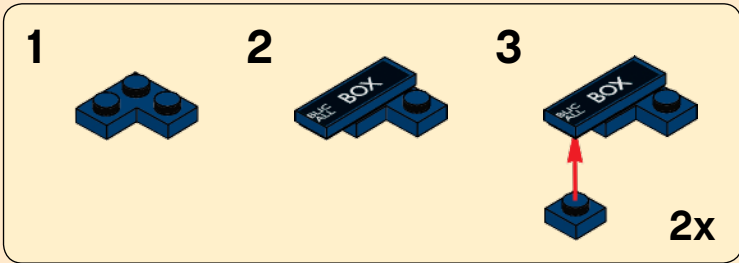



45

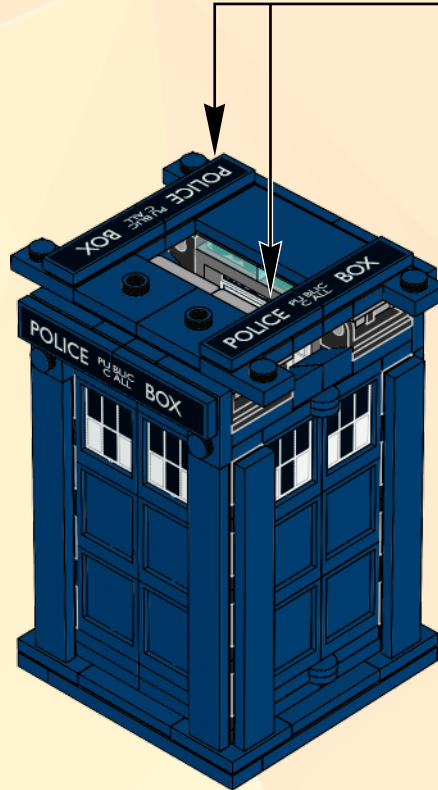
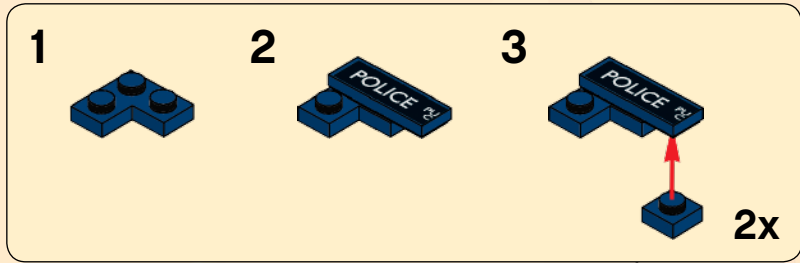

46

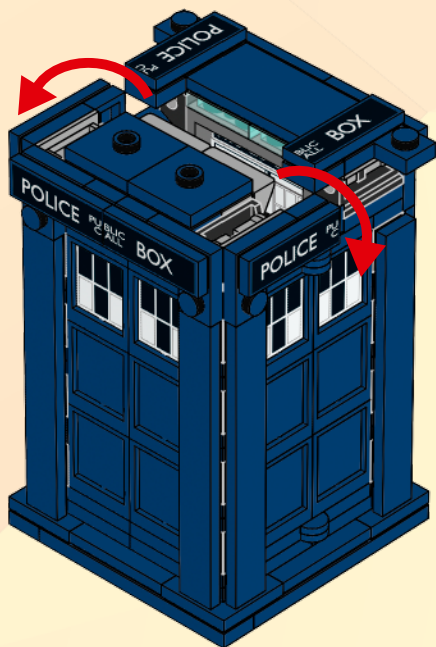

47

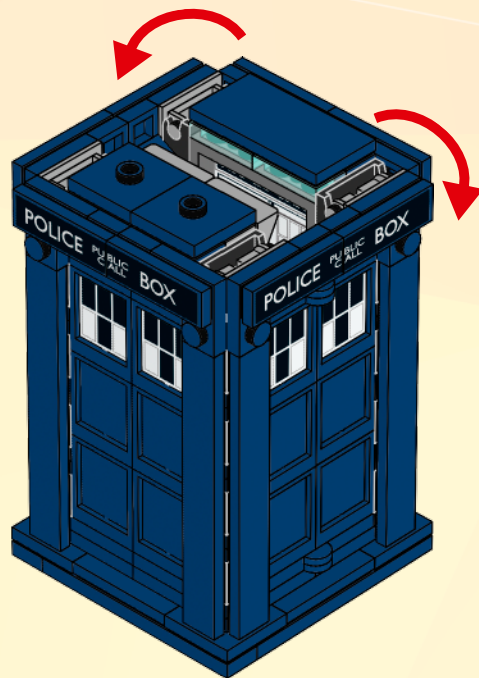

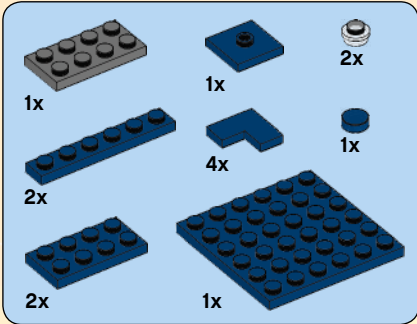
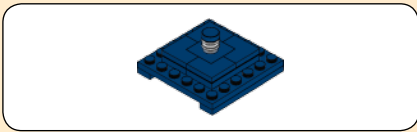

48

1

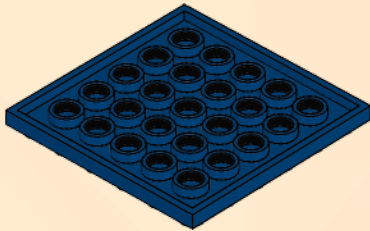

2

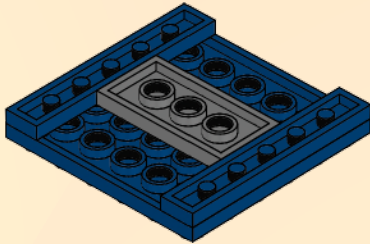

3

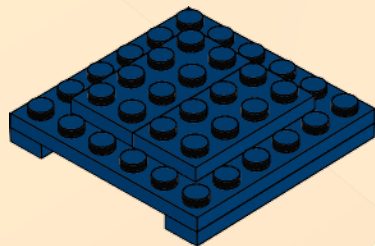
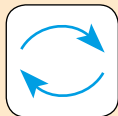

4

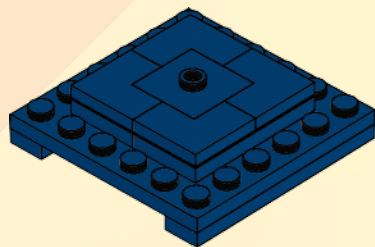

5

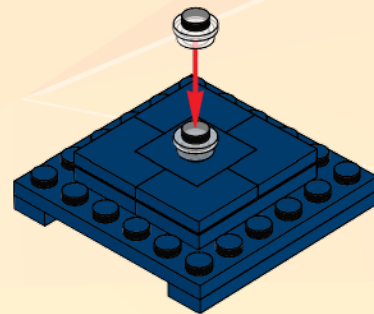

6

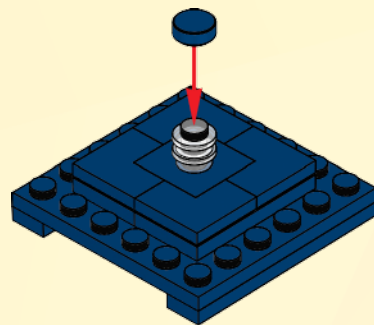



The exterior of the TARDIS should change to match its environment, but its "Chameleon Circuit" developed a fault.

L'extérieur du TARDIS doit changer pour correspondre à son environnement, mais son « Circuit caméléon » a développé un défaut.

El exterior de la TARDIS debería cambiar para camuflarse con el entorno, pero su «circuito camaleónico» está averiado.



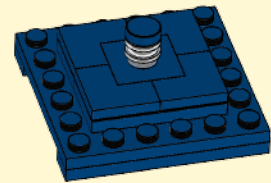
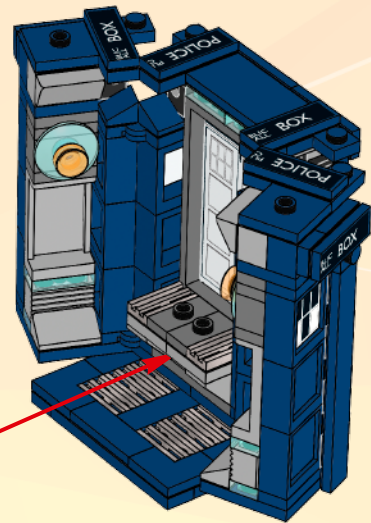
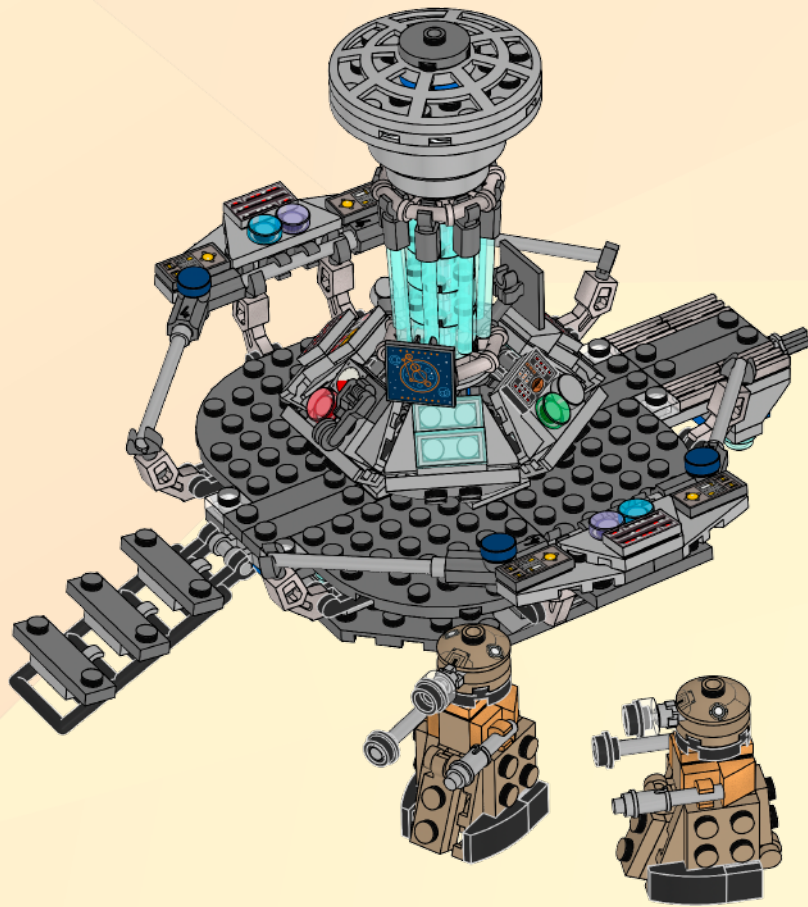



This product started out with a great project idea submitted by Andrew Clark and was transformed into a true LEGO® model by LEGO Product Designer Samuel Johnson and LEGO Graphic Designer Adam Corbally.



Andrew Clark

“I work as a Senior Artist on digital games, and I wanted to try something else that was creative. I looked to my childhood, and the fun I had with LEGO bricks. I looked at all the amazing things people were now doing with LEGO models and felt inspired!

I joined LEGO forums, and heard about LEGO Cuusoo, now LEGO Ideas. To be able to submit my own designs that could become an official LEGO set was compelling! I immediately set out to create my own designs, I had to try!

When LEGO Ideas announced they would accept projects based on *Doctor Who* I was excited. I immediately started a design, and through constant iteration, it was refined. Getting the best LEGO representation of the TARDIS was crucial, as was emulating its “bigger on the inside” feature.

Working with LEGO Product Designer Sam Johnson was a great experience; he managed to better incorporate the opened TARDIS into the interior, and console. He made other improvements, and I felt lucky to have him working on it.

Now my mind is thinking of future LEGO Ideas projects!”





“Growing up, my uncle (Paul McGann) was cast as the Eighth Doctor which was an extremely exciting time. And as soon as I saw this project, I wanted to be the designer soooo bad!

It was fun to work on the prototype from Andrew, making it more stable and even possible to pick up the entire set, so it can be moved around. I even built in the feature that allows the Doctor to be placed inside the TARDIS.”

Samuel Johnson

Product Designer, The LEGO Group

“I’m a big fan of the rebooted *Doctor Who* series, so I was thrilled to have the chance to work on the graphics for the model. We managed to include some really awesome details, like the Eleventh Doctor’s cool bow tie, but my favorite would be the alternative face for the terrifying, Weeping Angel! I hope all you Whovians like it... Geronimo!”

Adam Corbally

Graphic Designer, The LEGO Group



Ce produit a commencé avec une excellente idée de projet envoyée par Andrew Clark, et transformée en vrai modèle LEGO® par le designer de produits LEGO Samuel Johnson et le graphiste LEGO Adam Corbally.



Andrew Clark

« Je travaille sur des jeux numériques comme artiste principal et je voulais essayer quelque chose d'autre de créatif. J'ai pensé à mon enfance et combien je m'amusais avec les briques LEGO. J'ai regardé toutes les choses merveilleuses que les gens faisaient avec les modèles LEGO et je me suis senti inspiré !

J'ai rejoint les forums LEGO et j'ai entendu parler de LEGO Cuusoo, maintenant appelé LEGO Ideas. Pouvoir envoyer mes propres modèles susceptibles de devenir un ensemble LEGO officiel était fascinant ! J'ai immédiatement commencé à créer mes propres modèles, je devais essayer !

Lorsque LEGO Ideas a annoncé que les projets basés sur *Doctor Who* seraient acceptés, j'étais très excité. J'ai immédiatement commencé un modèle, et je l'ai perfectionné en le retravaillant. Obtenir la meilleure représentation LEGO du TARDIS était essentiel et je voulais reproduire sa fonction « plus grand à l'intérieur qu'à l'extérieur ».

Travailler avec le designer de produits LEGO Sam Johnson a été une expérience géniale. Il a réussi à mieux intégrer le TARDIS ouvert dans l'intérieur et la console. Il a apporté d'autres améliorations et j'ai eu beaucoup de chance qu'il travaille sur mon modèle.

Je pense maintenant à de futurs projets LEGO Ideas ! »





« Quand j'étais jeune, mon oncle (Paul McGann) a obtenu le rôle du huitième Docteur. C'était une époque vraiment formidable. Et dès que j'ai vu ce projet, j'ai absolument voulu être le designer !

• Ce fut amusant de travailler sur le prototype d'Andrew, pour le rendre plus stable et que l'ensemble entier puisse être soulevé afin de pouvoir le déplacer. J'ai même construit la fonction qui permet au Docteur d'être placé à l'intérieur du TARDIS.

Samuel Johnson

Designer de produits, le Groupe LEGO

« Je suis un grand fan de la série *Doctor Who* réinitialisée, j'ai donc été ravi d'avoir la chance de travailler sur les graphiques pour le modèle. Nous avons réussi à inclure des détails vraiment géniaux, comme le nœud papillon super cool du onzième Docteur, mais mon préféré est le visage alternatif pour l'Ange pleureur terrifiant. J'espère que tous les Whoviens vont l'aimer... Géronimo ! »

Adam Corbally

Graphiste, le Groupe LEGO



Este producto nació a partir de una gran idea enviada por Andrew Clark y se transformó en un auténtico modelo LEGO® gracias a Samuel Johnson (diseñador de productos LEGO) y Adam Corbally (diseñador gráfico de LEGO).



Andrew Clark

«Soy artista sénior; me dedico a los juegos digitales y quería probar algo que fuese creativo. Recordé mi niñez y lo divertido que era jugar con mis bricks LEGO. ¡Vi todas las cosas asombrosas que la gente hacía hoy con sus modelos LEGO y esa fue mi inspiración!

Me registré en los foros de LEGO y oí hablar de LEGO Cuusoo, que hoy se llama LEGO Ideas. ¡Poder enviar mis propios diseños y tener la oportunidad de que se convirtieran en un set LEGO oficial era increíble! Inmediatamente me puse a crear mis propios diseños. ¡Tenía que intentarlo!

Cuando LEGO Ideas anunció que aceptaría nuevos proyectos basados en el Doctor Who, no me lo creía. Empecé a diseñar y, tras varias etapas, conseguí algo que merecía la pena. Conseguir la mejor representación de la TARDIS con bricks LEGO era fundamental, como lo era también simular el hecho de que “es más grande por dentro”.

Trabajar con Sam Johnson (diseñador de productos LEGO) fue una gran experiencia; él fue quien consiguió incorporar mejor la TARDIS abierta en el interior, así como la consola. También hizo otras mejoras y me sentí afortunado de que trabajase en mi modelo.

¡Ahora no hago más que pensar en mis futuros proyectos LEGO Ideas!»





«Cuando era joven, mi tío (Paul McGann) interpretó al octavo Doctor, lo cual significó mucho para mí. ¡En cuanto vi este proyecto quise trabajar desesperadamente en él!

Fue muy divertido trabajar en el prototipo de Andrew, hacerlo más estable y aportar la posibilidad de sujetar el set completo para moverlo. Incluso construí la función que permite introducir al Doctor dentro de la TARDIS».

Samuel Johnson

Diseñador de productos, The LEGO Group

«Soy un gran fan de la nueva serie del Doctor Who, así que me encantó que me eligieran para diseñar las ilustraciones del modelo. Conseguimos incluir detalles asombrosos, como la divertida pajarita del undécimo Doctor, ¡pero mi favorito es la cara alternativa del terrorífico ángel Ilorón! Espero que les guste a todos los Whovianos... ¡Gerónimo!»

Adam Corbally

Diseñador gráfico, The LEGO Group







2x
4211396



1x
4650260



2x
6071229



6x
4654582



1x
4211632



1x
4211376



1x
4211404



14x
4507056



1x
6028015



2x
4211487



1x
6015349



2x
4211791



2x
4211794



2x
4211475



2x
4585429



4x
6093527



6x
6081975



1x
6129009



1x
6123037



1x
6134394



2x
4640844



2x
6074698



1x
4511007



1x
4211503



4x
4211470



2x
4211483



2x
4211622

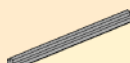

1x
4211805



2x
4667578



1x
6132558



1x
6134401



1x
6129598



3x
4210935



8x
4210862



2x
6092572



4x
4221879



6x
4211063



2x
4210635



9x
4598769



4x
4211065



1x
6071226



1x
4587212



6x
6000606



4x
4581225



2x
6055313



1x
6115080



4x
4500517



2x
4583688



1x
4535833



2x
6132560



2x
6037872



1x
4211081



8x
6015890



8x
4289542



4x
4210688



1x
4499858



6x
6020189



2x
4211111



1x
6134664



2x
6092594



4x
6071259



1x
6122423



4x
4587002



13x
4619636



2x
6020990



8x
6008483



1x
6134652



1x
4523794



1x
6134650



1x
4550736



1x
6127019



1x
6134644



1x
6123876

7

8



Customer Service
Kundenservice
Service Consommateurs
Servicio Al Consumidor
LEGO.com/service or dial

 : 00800 5346 5555
: 1-800-422-5346

TRAVEL WITH THE DOCTOR INTO ANOTHER DIMENSION



DIMENSIONS™

BBC

LEGO DIMENSIONS Videogame software © 2015 TT Games Ltd. Produced by TT Games under license from the LEGO Group. LEGO, the LEGO logo, the Brick and Knob configurations and the Minifigure are trademarks and/or copyrights of the LEGO Group. ©2015 The LEGO Group. BBC logo © BBC 1996. Doctor Who logo © BBC 2009. Dalek image © BBC/Terry Nation 1963. Cyberman image © BBC/Kit Pedler/Gerry Davis 1966. K-9 image © BBC/Bob Baker/Dave Martin 1977. Licensed by BBC Worldwide Limited. All other trademarks and copyrights are the property of their respective owners. All rights reserved.

VOYAGE AVEC LE DOCTEUR DANS UNE AUTRE DIMENSION



DIMENSIONS™

Logiciel de jeu vidéo LEGO DIMENSIONS © 2015 TT Games Ltd. Produit par TT Games avec l'autorisation de LEGO Group. LEGO, le logo LEGO, les configurations de la Brique et du Bouton, ainsi que Minifigure sont des marques de commerce ou des droits d'auteur de LEGO Group. ©2015 The LEGO Group. Logo BBC © BBC 1996. Logo Doctor Who © BBC 2009. Image Dalek © BBC/Terry Nation 1963. Image Cyberman © BBC/Kit Pedler/Garry Davis 1966. K-9 image © BBC/Bob Baker/Dave Martin 1977. Avec autorisation de BBC Worldwide Limited. Toutes les autres marques de commerce et droits d'auteur sont la propriété de leurs propriétaires respectifs. Tous droits réservés.

VIAJA CON EL DOCTOR A OTRA DIMENSIÓN



BBC

LEGO

DIMENSIONS™

LEGO DIMENSIONS Videogame software © 2015 TT Games Ltd. Producido por TT Games con licencia de LEGO Group. LEGO, el logotipo de LEGO, las configuraciones Brick y Knob y la Minifigura son marcas de fábrica y/o derechos de autor de LEGO Group. ©2015 The LEGO Group. Logotipo de BBC © BBC 1996. Logotipo de Doctor Who © BBC 2009. Imagen de Dalek © BBC/ Terry Nation 1963. Imagen de Cyberman © BBC/Kit Pedler/Gerry Davis 1966. Imagen de K-9 © BBC/Bob Baker/Dave Martin 1977. Con licencia de BBC Worldwide Limited. Todas las marcas comerciales y los derechos de autor son propiedad de sus respectivos titulares. Todos los derechos reservados.



IDEAS

A WHOLE UNIVERSE OF INNOVATIVE LEGO® IDEAS

Do you have an exciting idea for a LEGO® model? Then why not make it into a LEGO Ideas project? You can share your product concept on [LEGO.com/ideas](https://www.lego.com/ideas) and see what other people think about it.

If your project gains 10,000 supporters, it will automatically qualify for the quarterly LEGO Review. This is where we take an in-depth look at the most popular projects and carefully evaluate them to discover the idea with the most potential. If your project makes it through the review, it will become an official LEGO product.

There are tens of thousands of active members, and thousands of product ideas on LEGO Ideas – several of which have become hit LEGO sets! So take a look, sign up, and support your favorite ideas, or even better: upload your own!

LEGO.COM/IDEAS

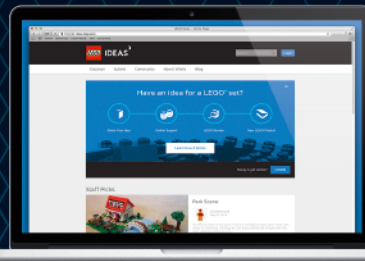



IDEAS

TOUT UN UNIVERS D'IDÉES LEGO® NOVATRICES

As-tu une idée de modèle LEGO® passionnante ? Alors pourquoi ne pas en faire un projet LEGO Ideas ? Tu peux partager ton concept de produit sur lego.com/ideas et voir ce que les autres en pensent.

Si ton projet obtient l'appui de 10 000 personnes, il sera automatiquement qualifié pour l'examen LEGO trimestriel. Cet examen nous permet d'étudier en profondeur les projets les plus populaires et de les évaluer attentivement pour découvrir les idées ayant le plus grand potentiel. Si ton projet passe l'examen, il deviendra alors un produit LEGO officiel.

Il y a des dizaines de milliers de membres actifs et des milliers d'idées de produits sur LEGO Ideas, et plusieurs d'entre elles sont devenues des ensembles LEGO très populaires ! Alors va regarder, inscris-toi et soutiens tes idées préférées. Ou mieux encore : télécharge ton propre projet !

LEGO.COM/IDEAS

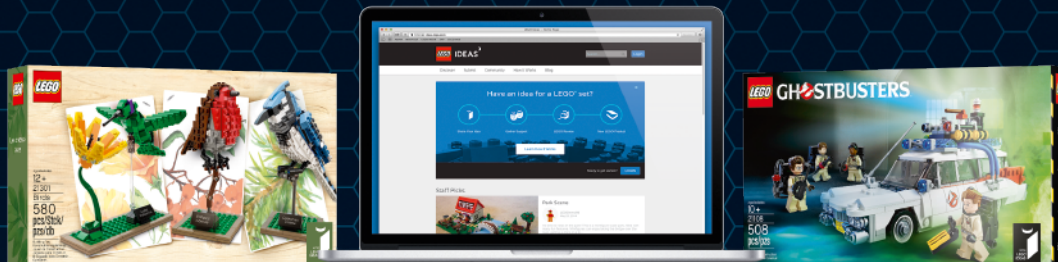



IDEAS

TODO UN UNIVERSO DE INNOVADORAS IDEAS LEGO®

¿Tienes una buena idea para un modelo LEGO®?
¿Por qué no convertirla en un proyecto LEGO Ideas?
Puedes compartir tu idea en LEGO.com/ideas y ver lo que los demás piensan de ella.

Si tu proyecto consigue 10.000 votos, se clasificará automáticamente para la revisión trimestral de LEGO. Es entonces cuando daremos un vistazo a los proyectos más populares y los evaluaremos detenidamente para determinar qué idea tiene más potencial. Si tu proyecto supera la revisión, se convertirá en un producto LEGO oficial.

Hay decenas de miles de miembros activos y miles de ideas en LEGO Ideas (varias de las cuales ya se han convertido en sets LEGO de gran éxito). Ven a dar un vistazo, regístrate y apoya tus ideas favoritas. O aún mejor: ¡envía la tuya!

LEGO.COM/IDEAS

