



PIRATES *of the* CARIBBEAN

ON STRANGER TIDES



4193



1

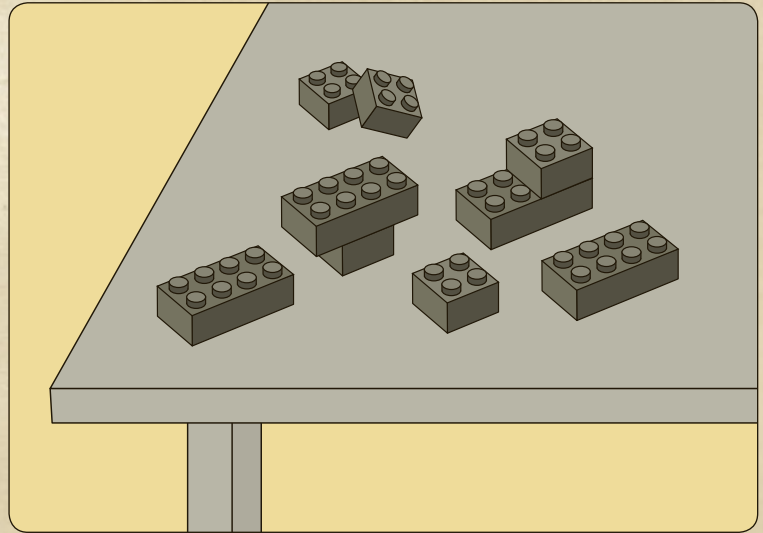
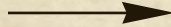
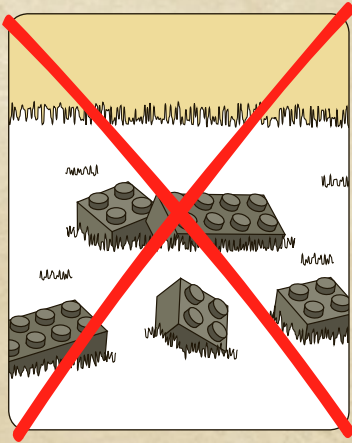

2



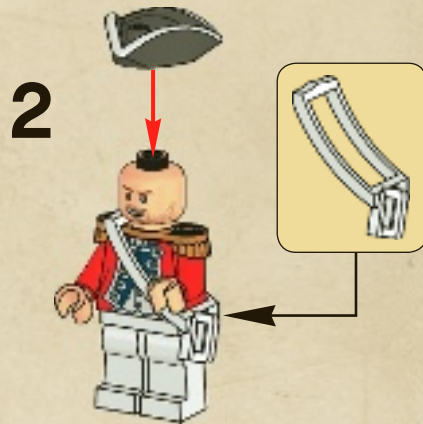
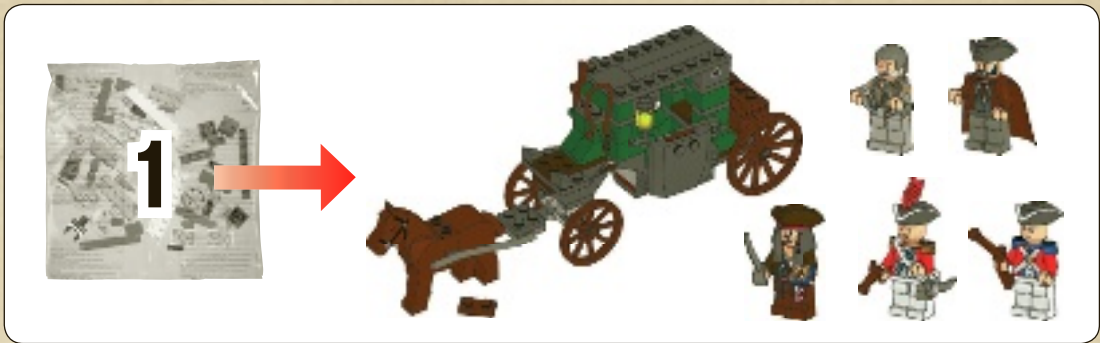

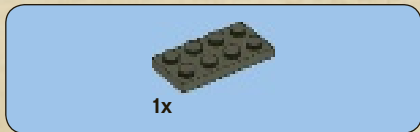
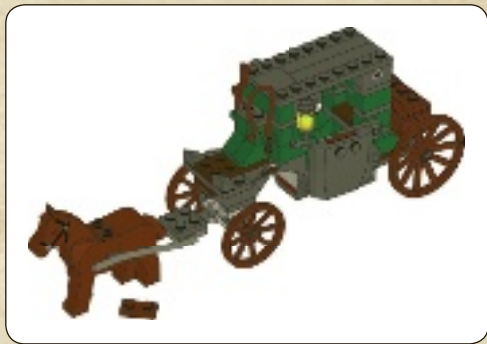

1



2

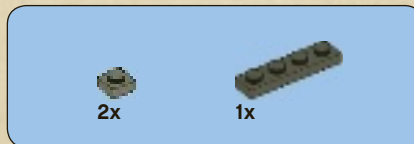
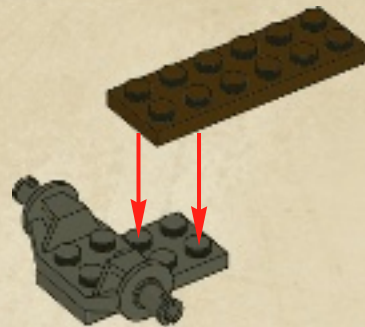

3

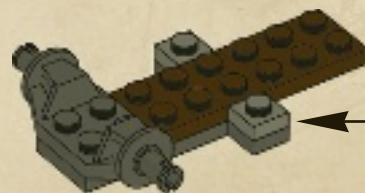
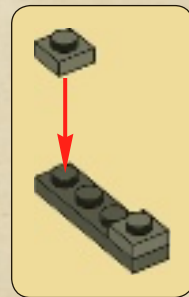



4

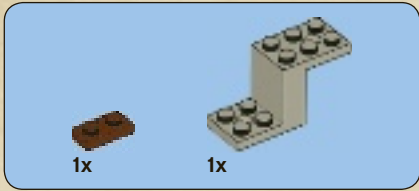
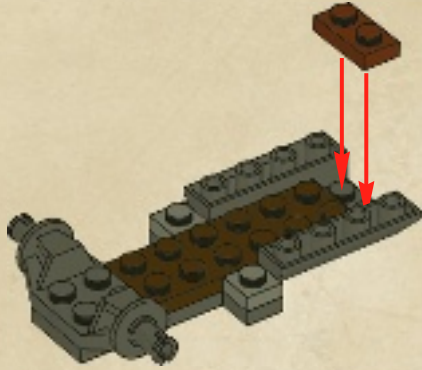

5

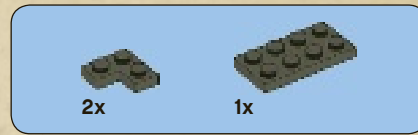
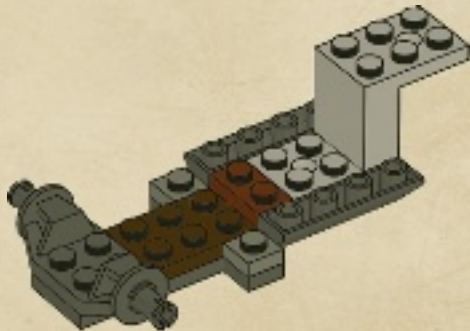

6

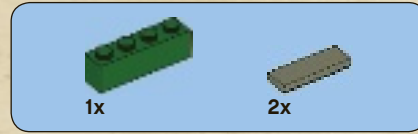
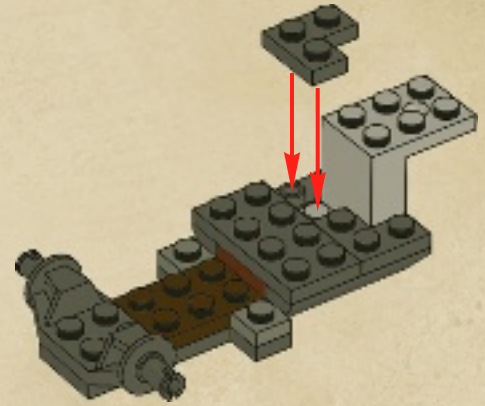

7

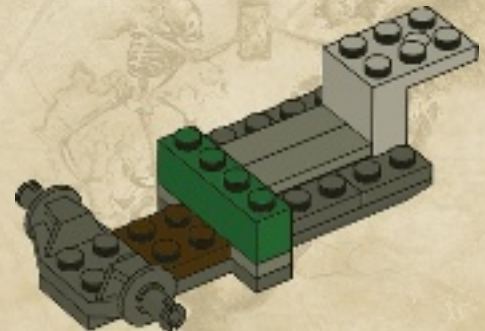

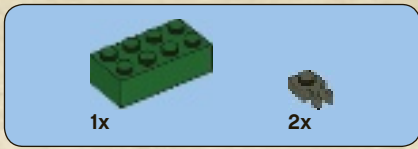

8

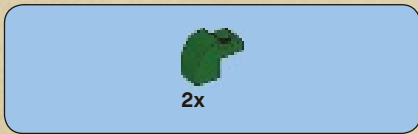
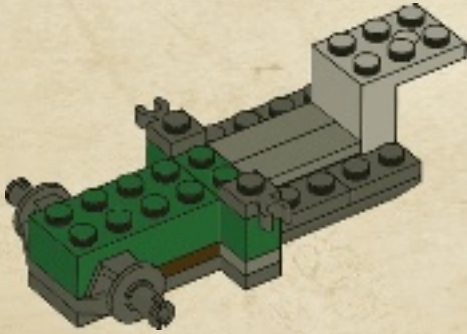

9

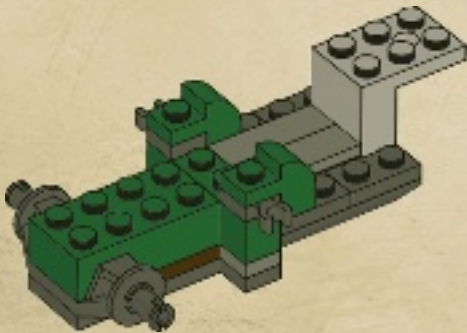

10

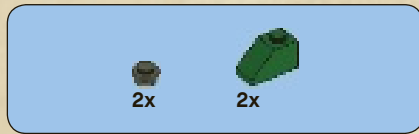
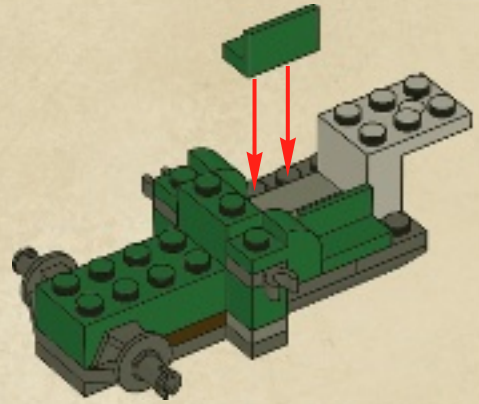

11

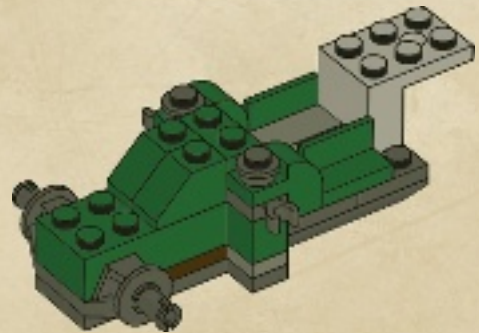

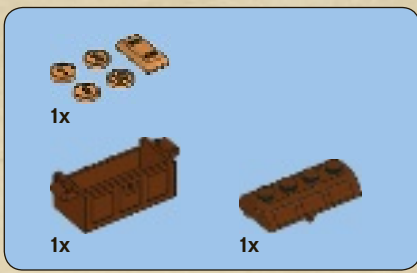

12

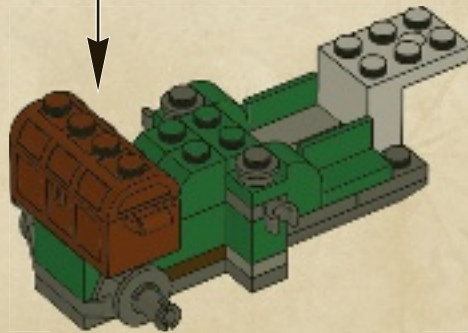
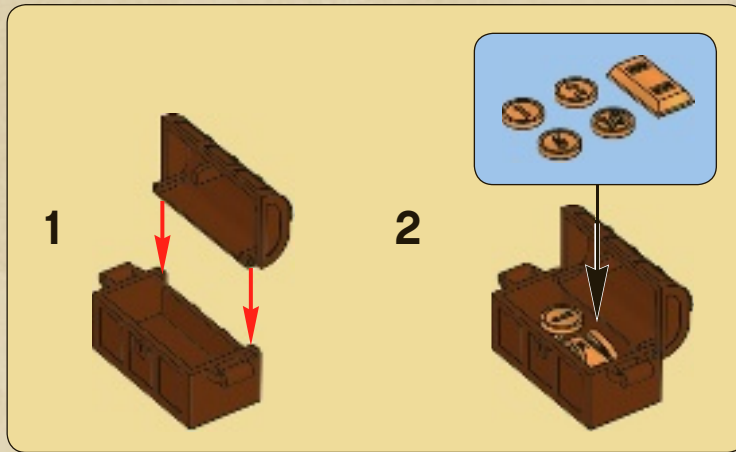

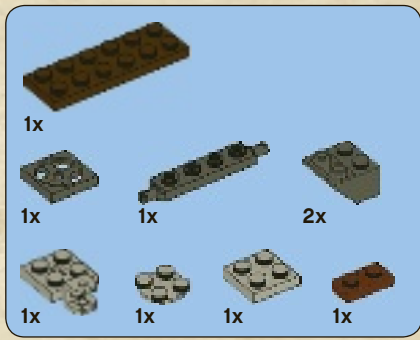

13

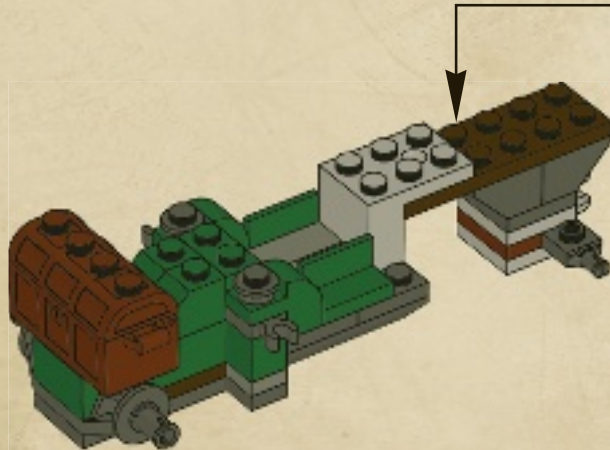
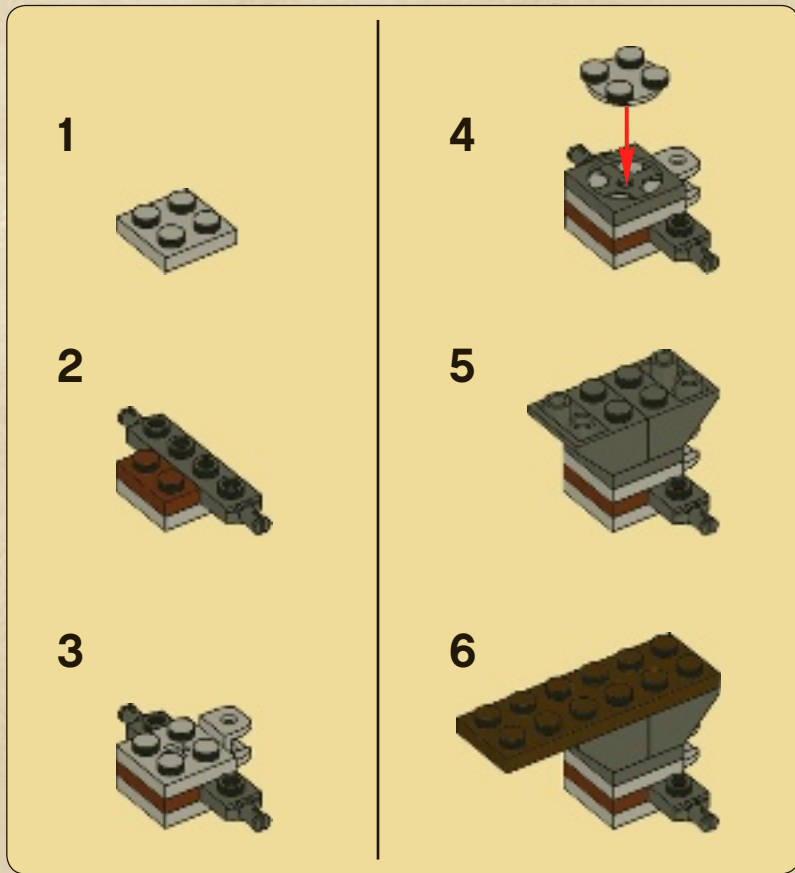



1x



1x

14

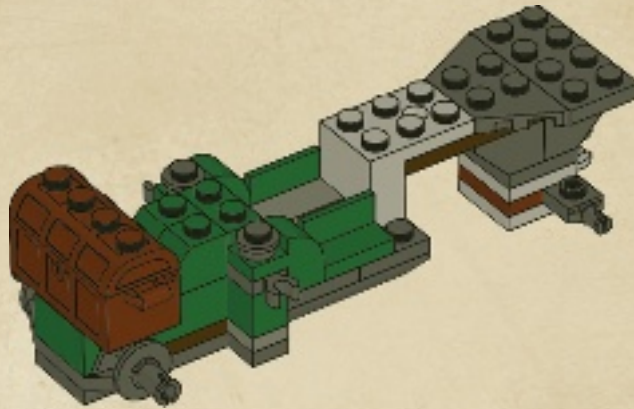

2x



1x

15

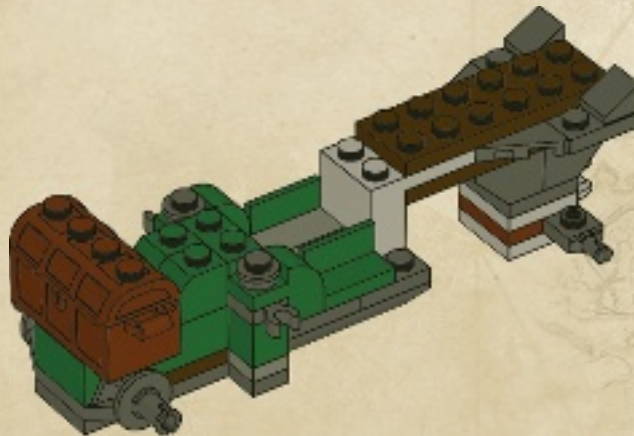



2x

16

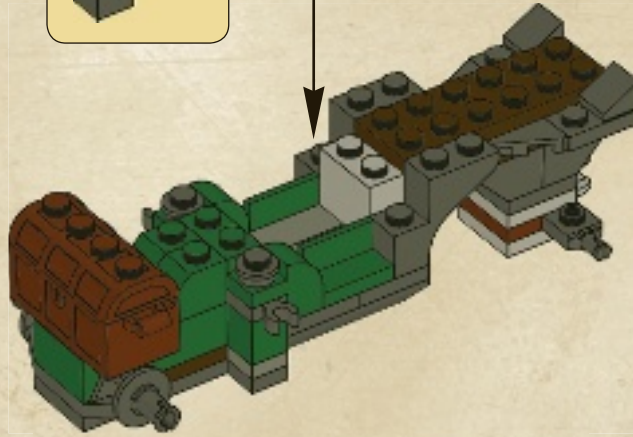
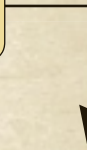
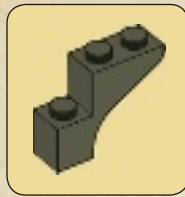

2x



1x

17

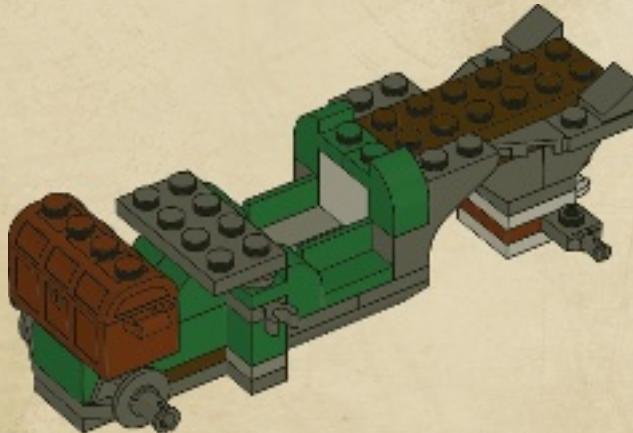



1x



2x

18

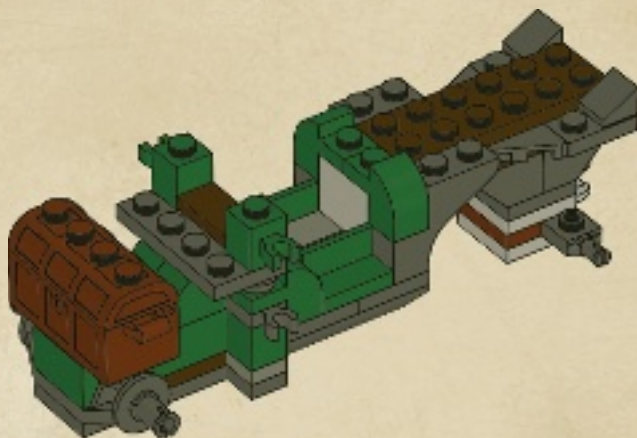

1x

19

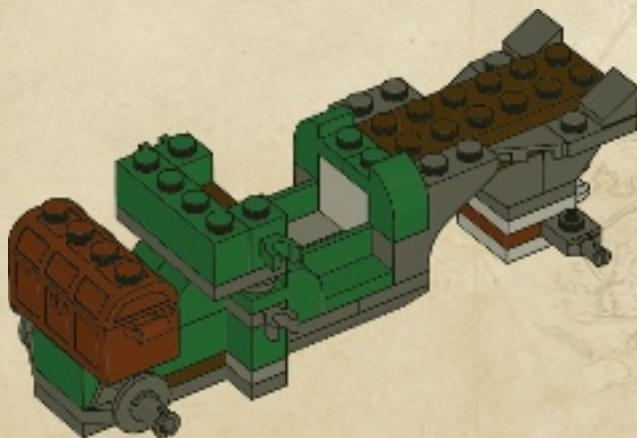



2x

20

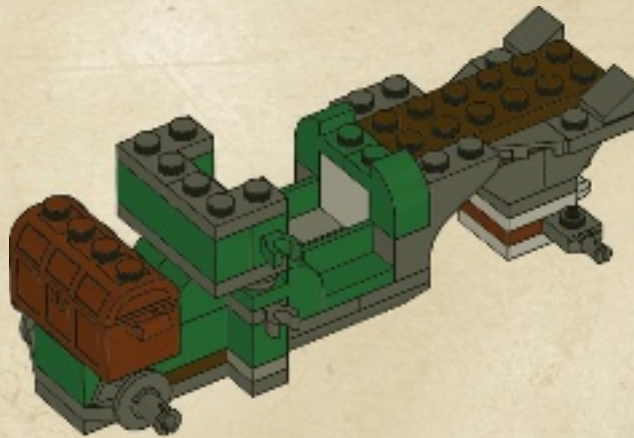

3x

21

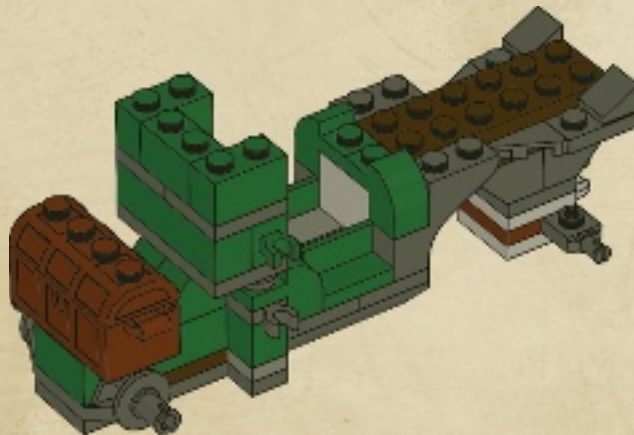



2x

22

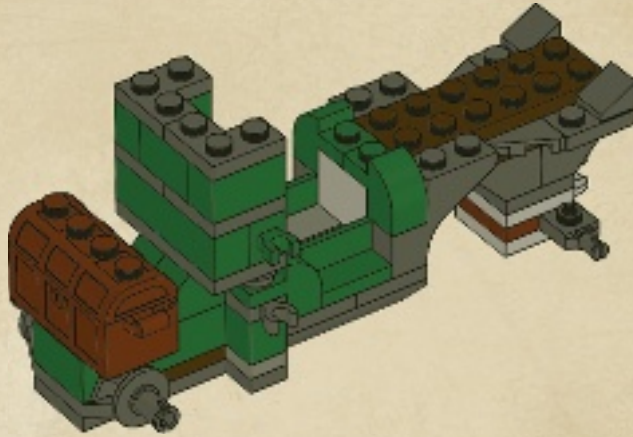

1x



2x



1x

23



2x

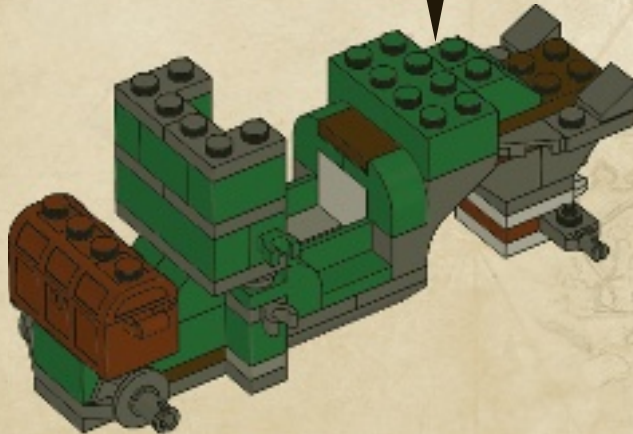



24

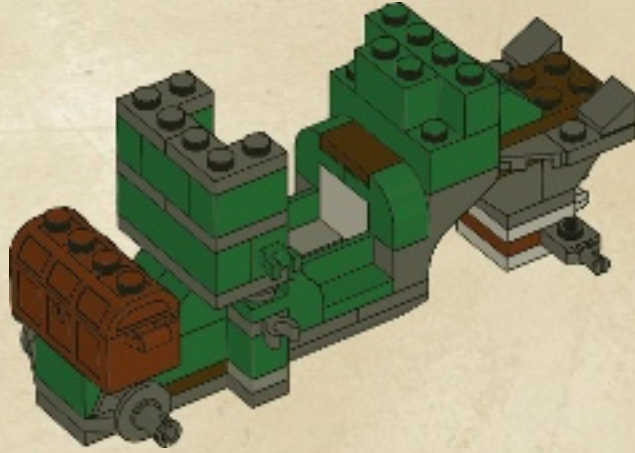

25

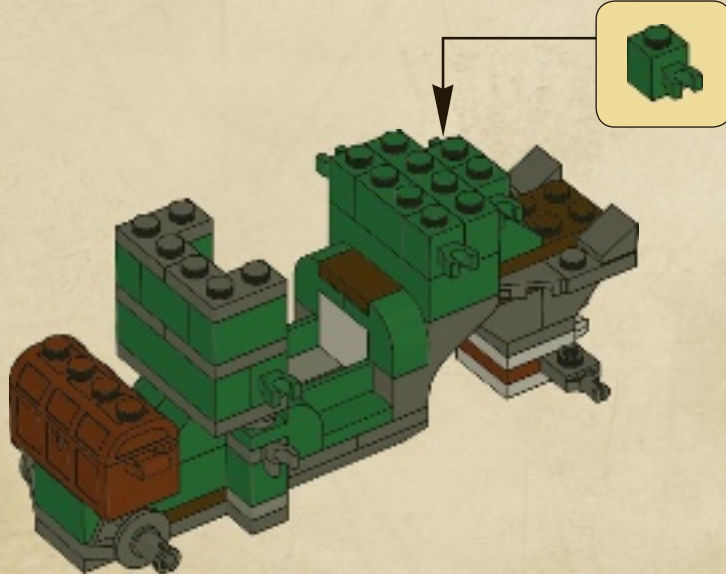



2x



1x

26

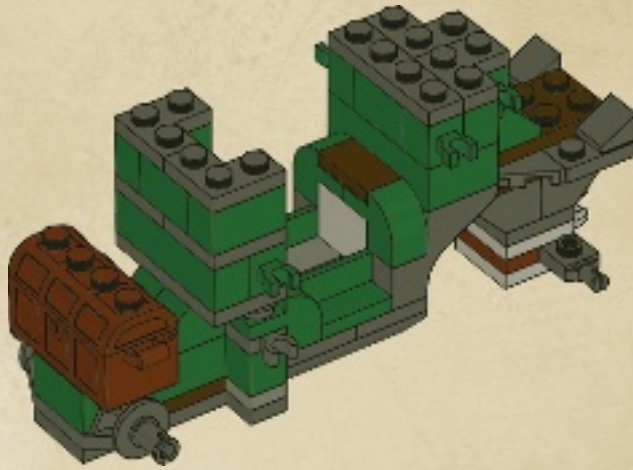

1x



2x



1x

27

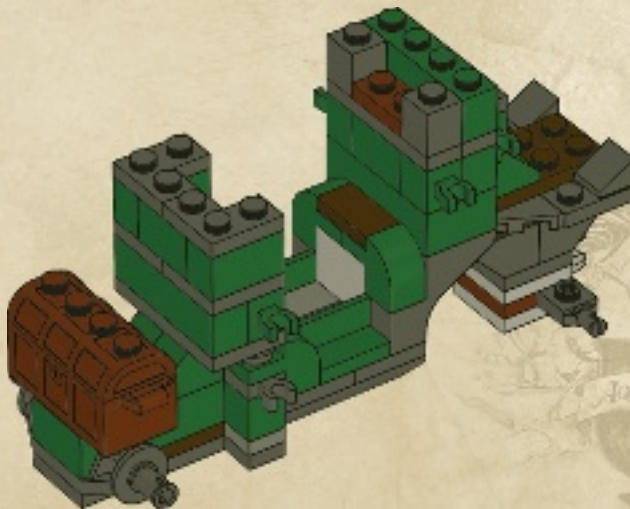

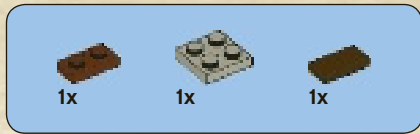

28

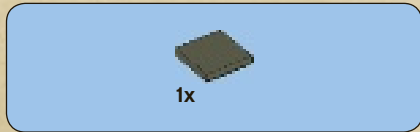
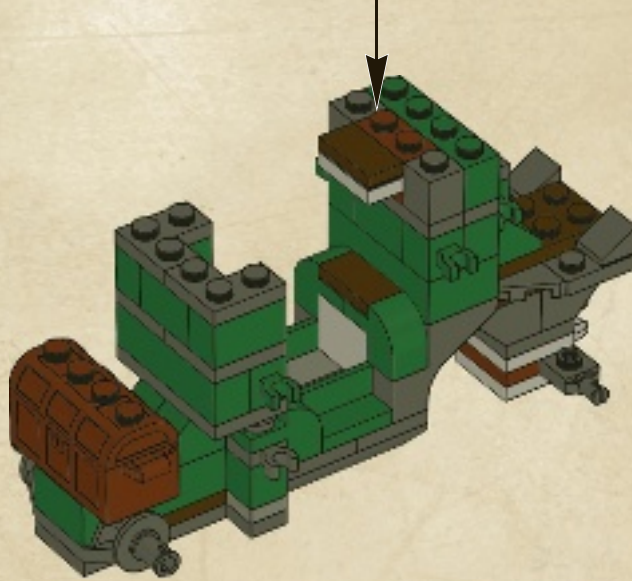

29

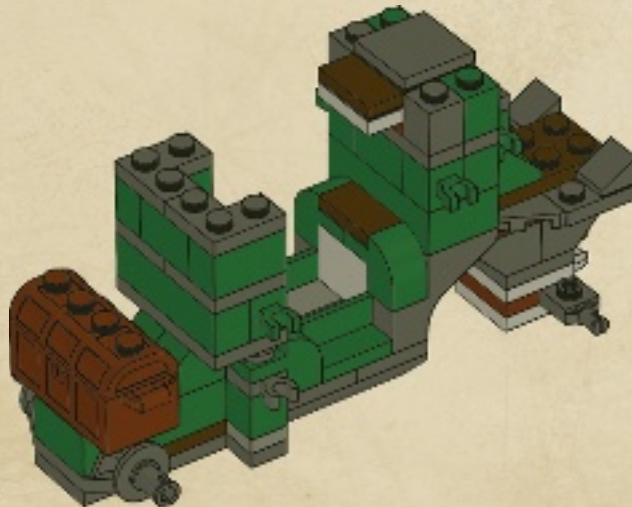

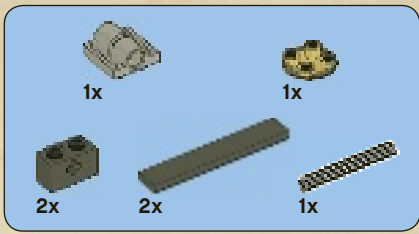

30

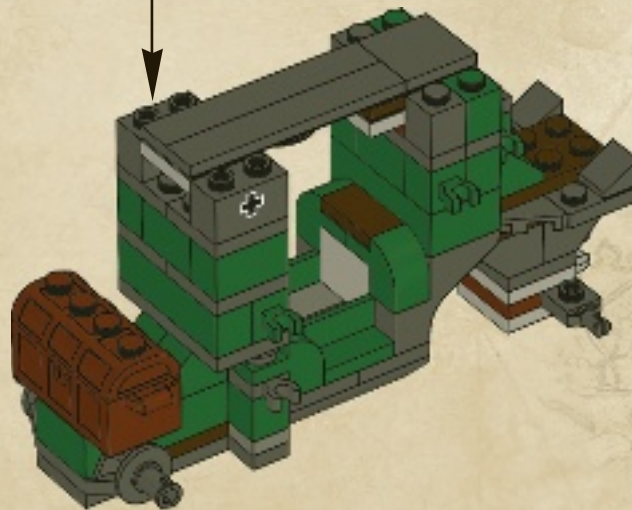
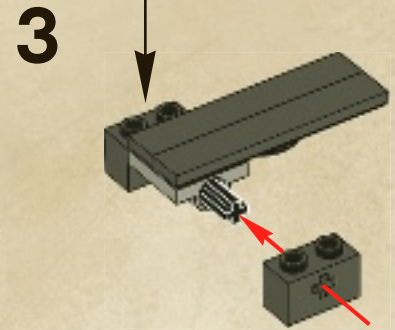
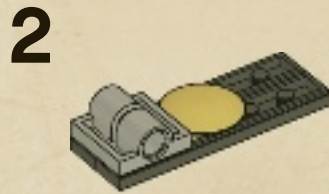
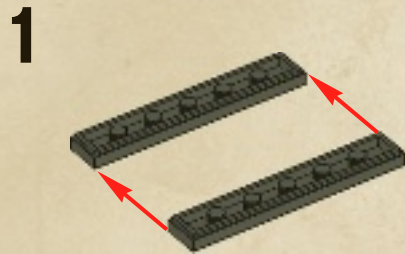
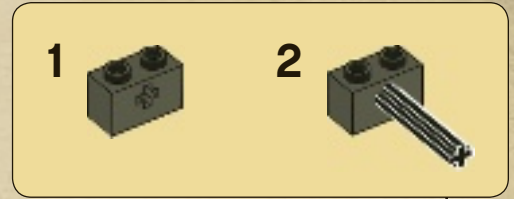

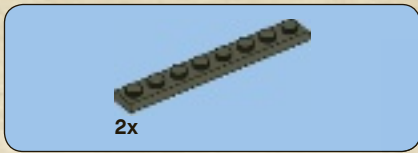

31

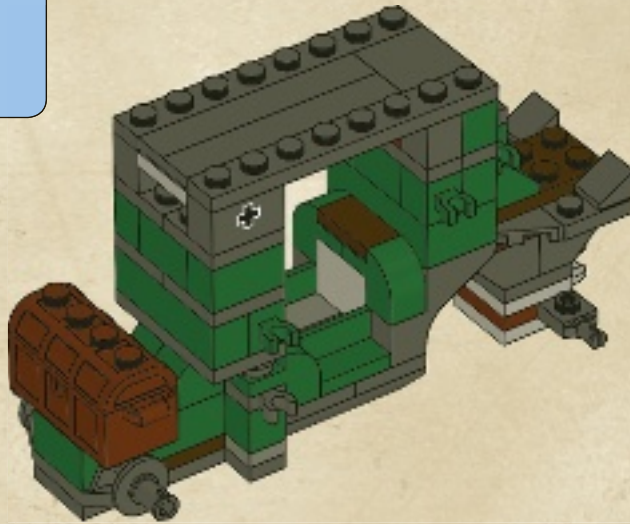

32

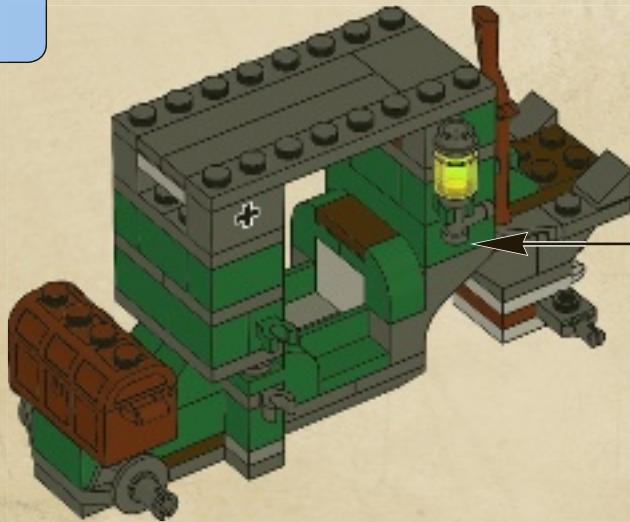

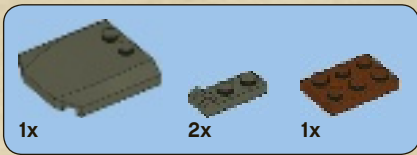

33

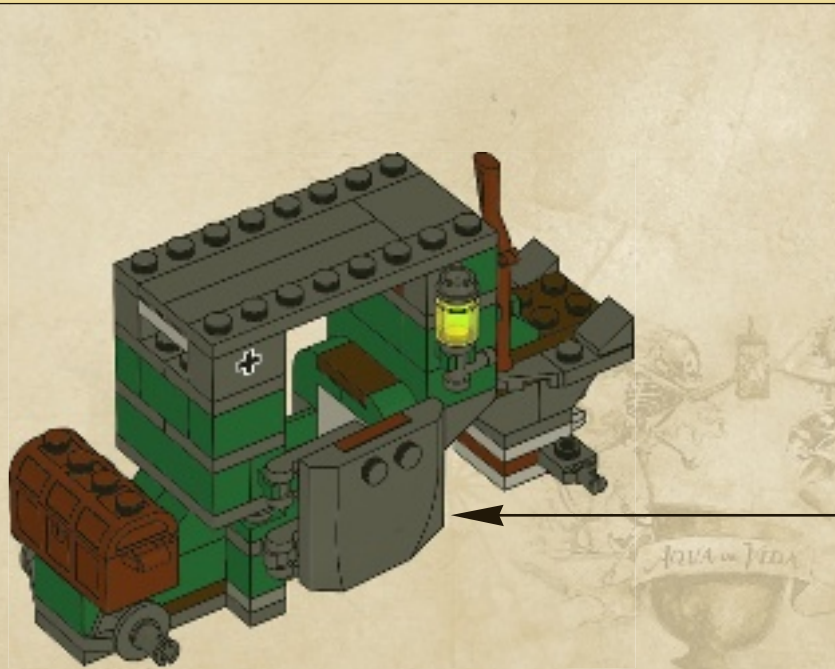

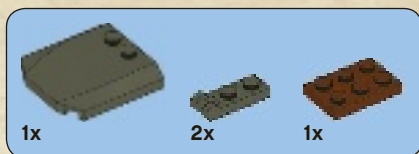

34

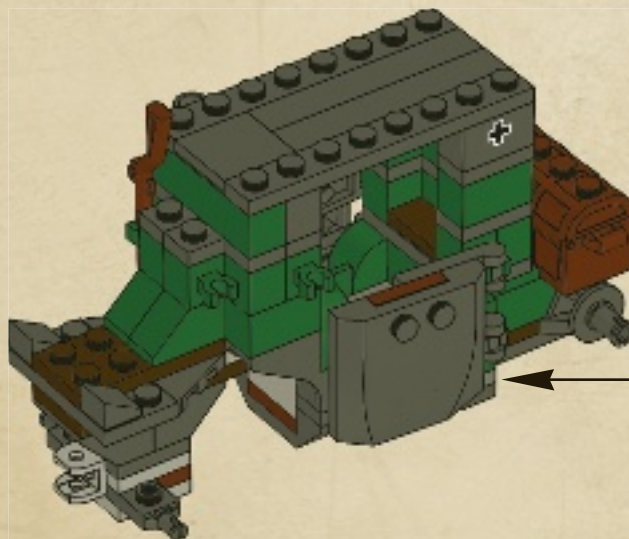

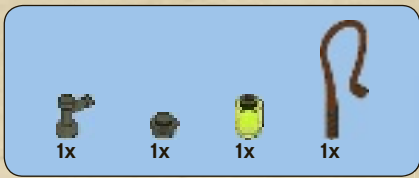

35

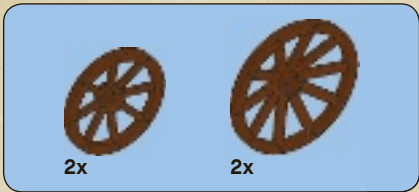
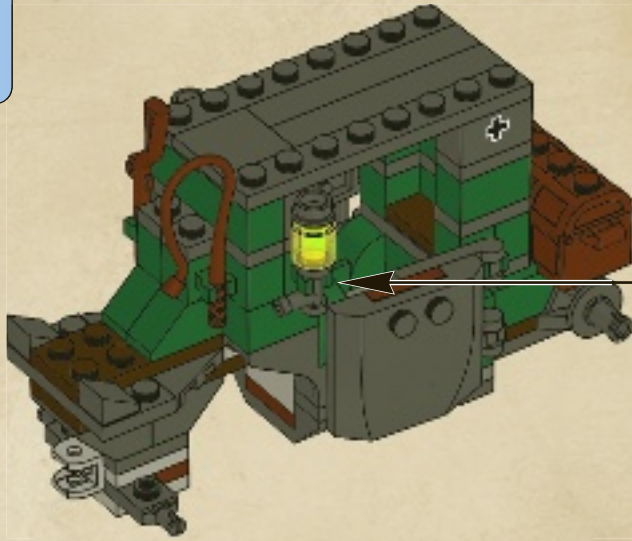

36

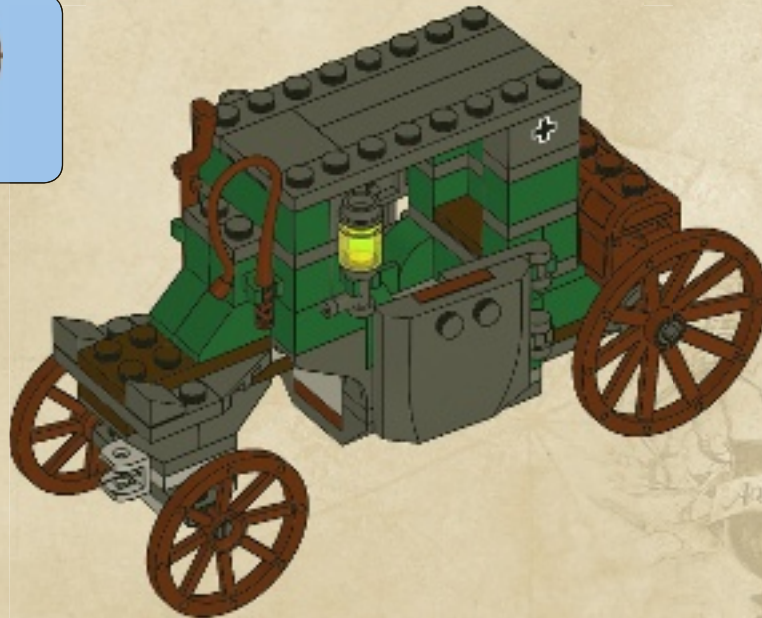

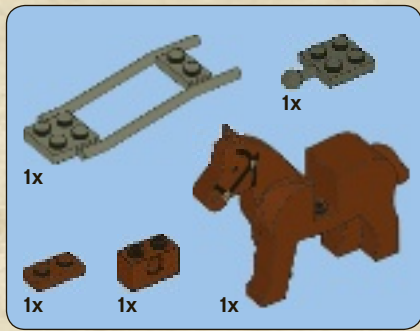

37

1



2



3

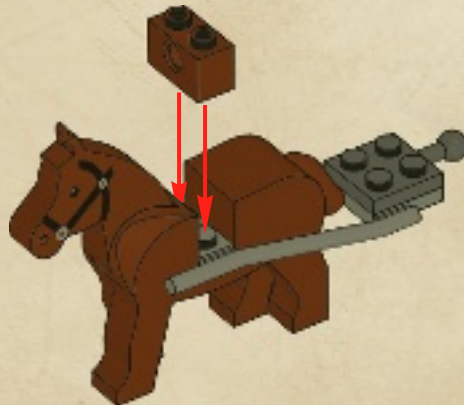

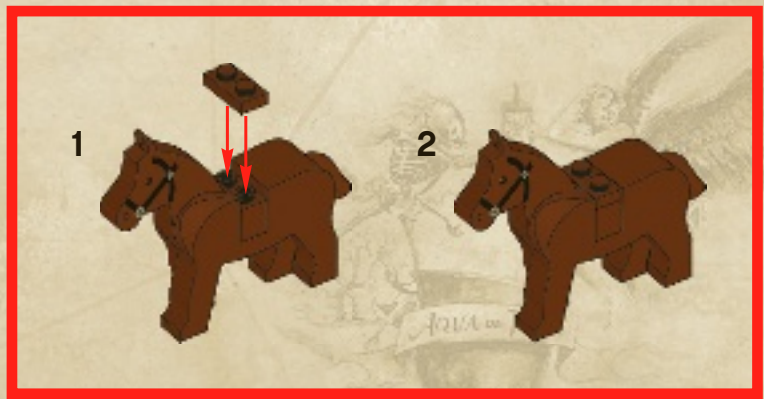
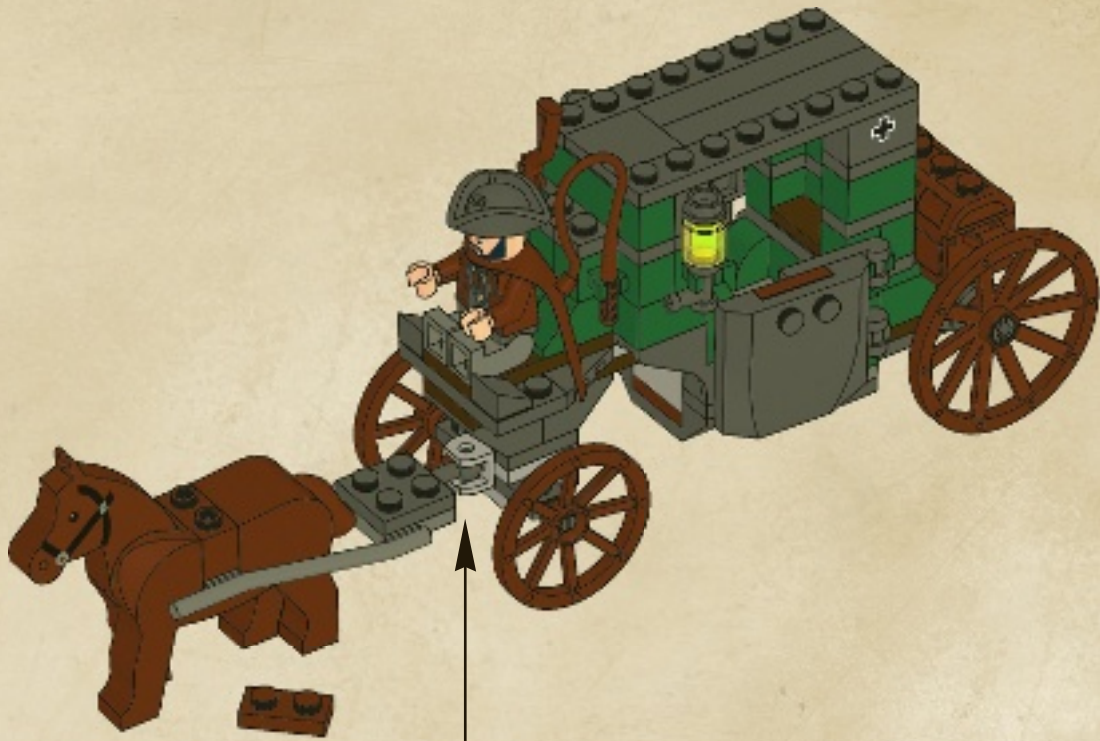

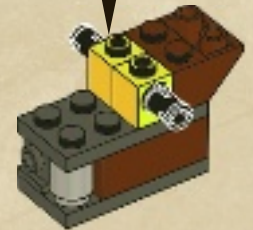
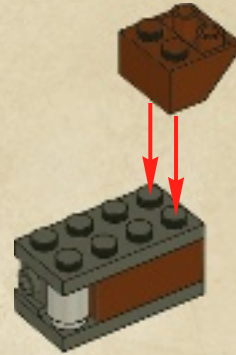
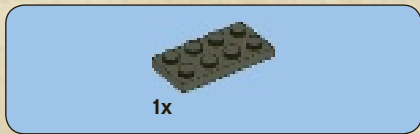
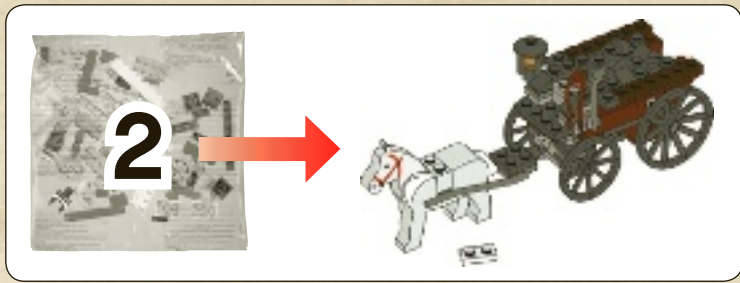



2x



1x

5

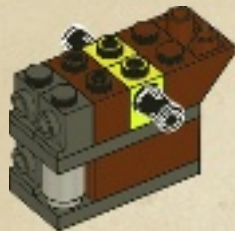

1x



1x

6



1x



1x

7



1x



1x

8





1x



2x

9

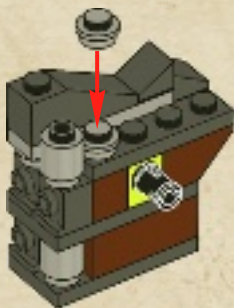

1x



2x

10



3x

11

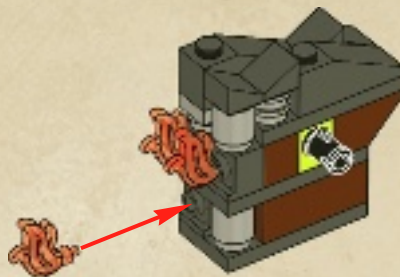

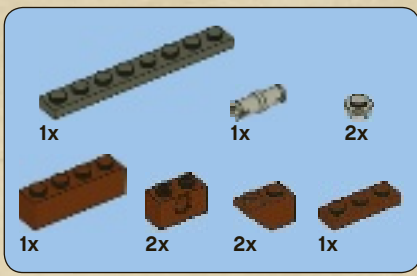

12

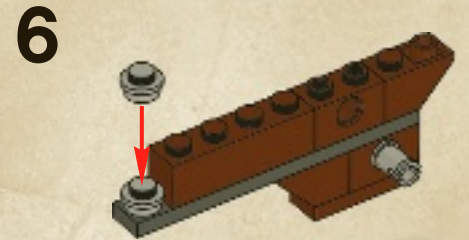
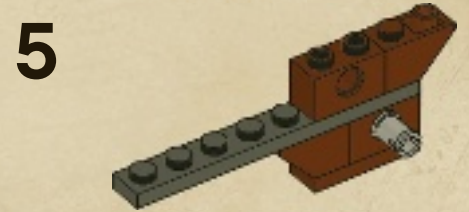
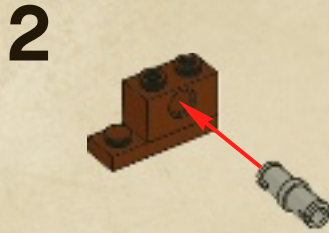

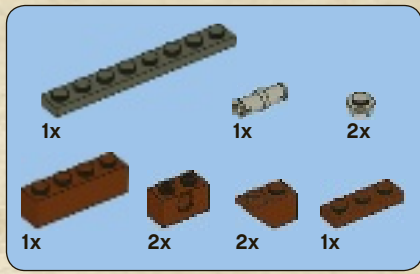

13

1

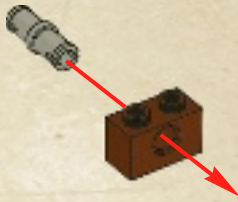

2

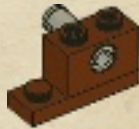

3



4

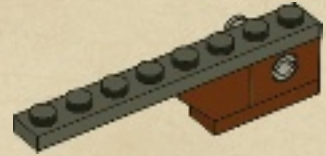

5

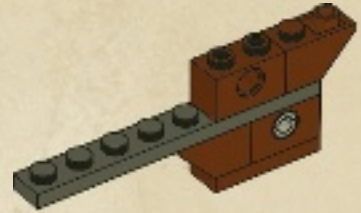

6

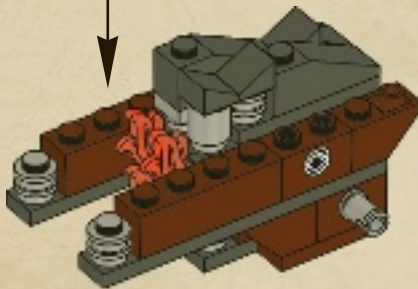
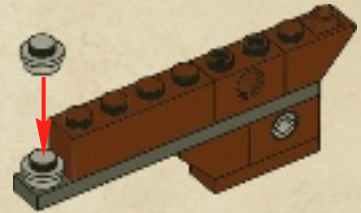

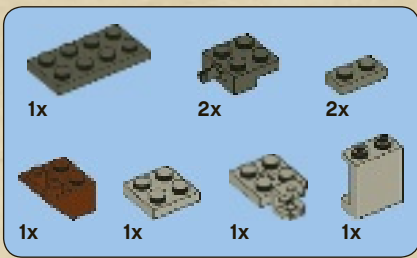

14

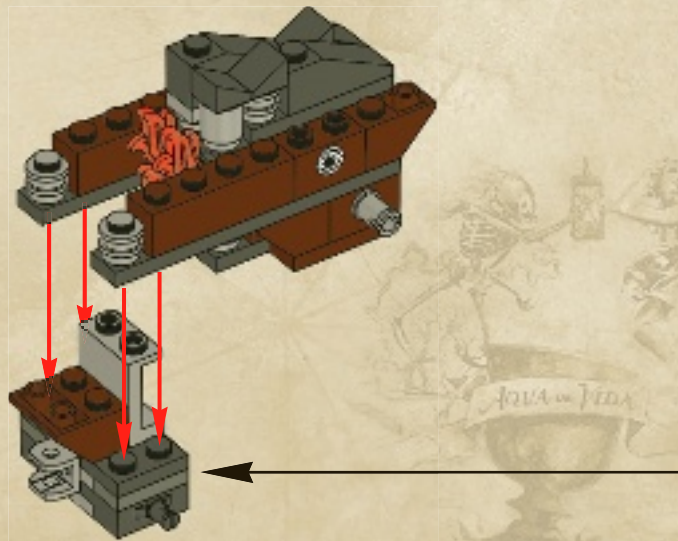
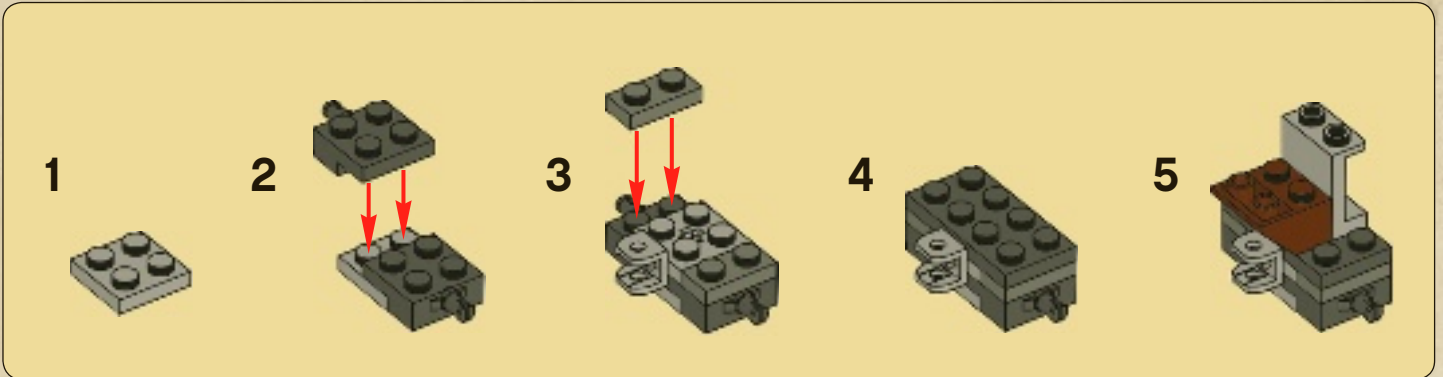



1x

15

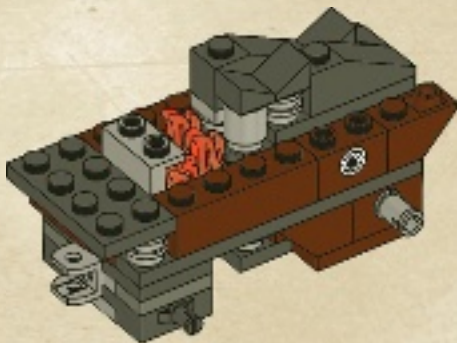

4x

16

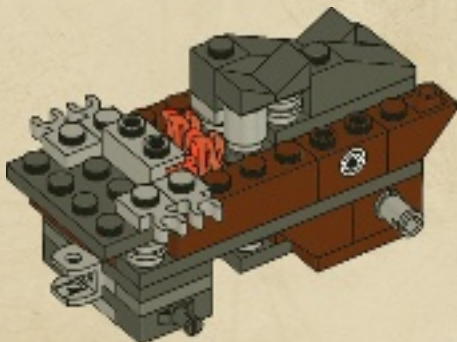



2x

17

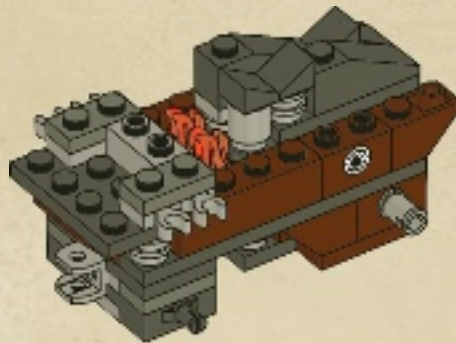

1x



2x

18

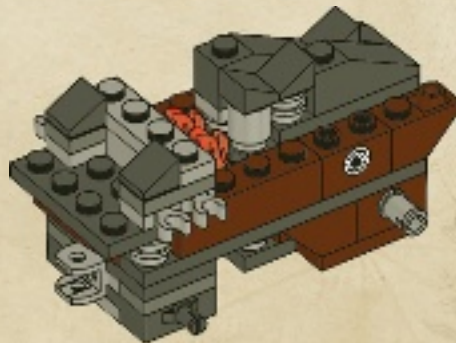



6x

19



2x

20

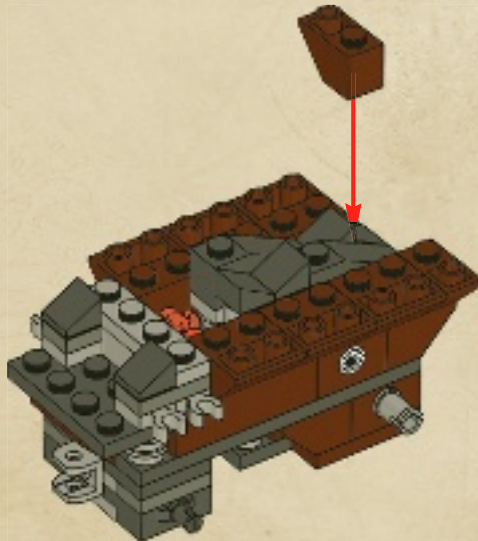

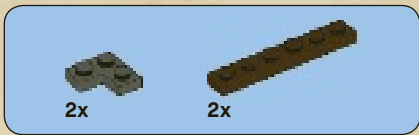

21

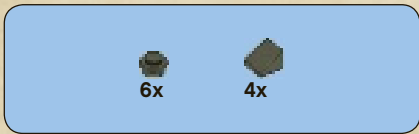
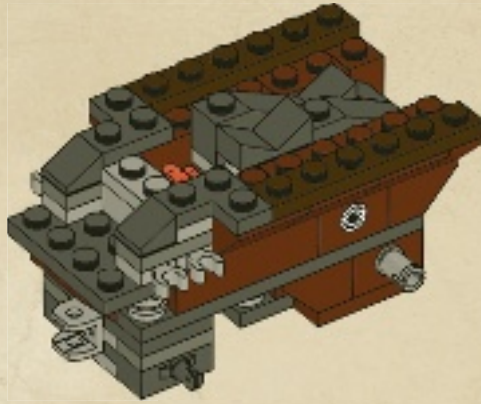

22

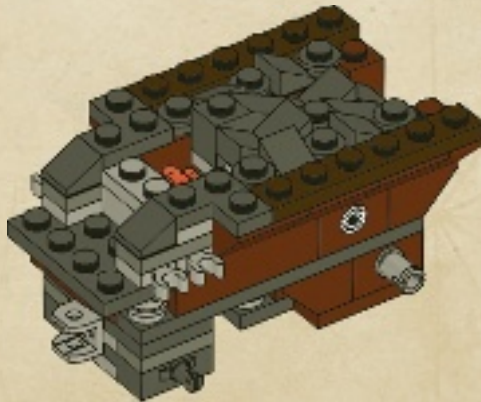



23

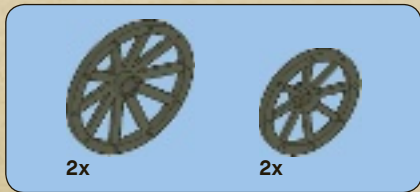
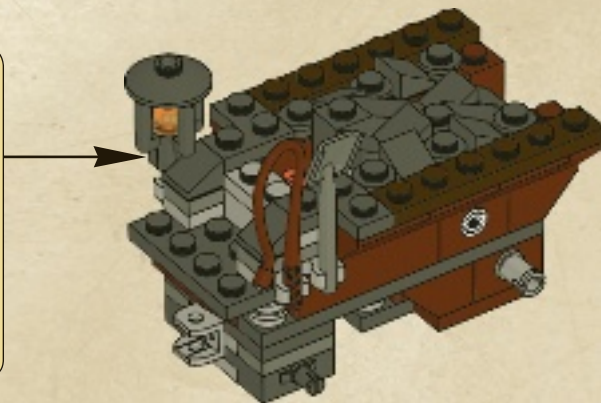
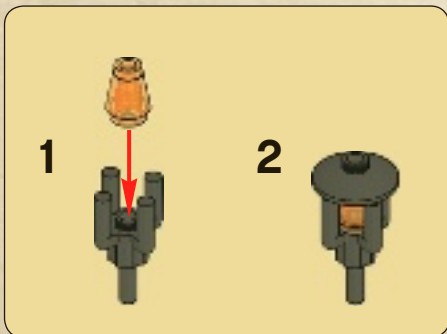

24



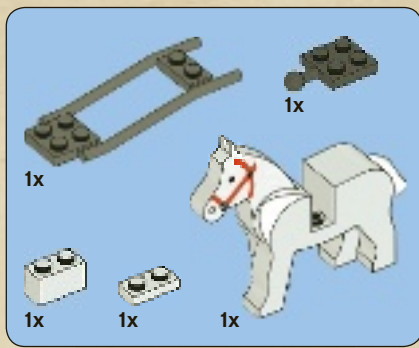

25

1



2

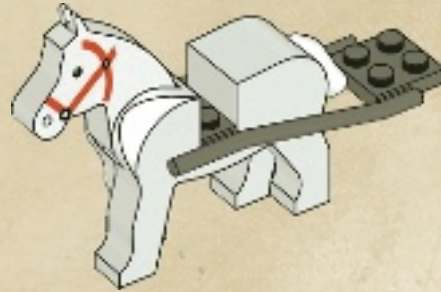

3

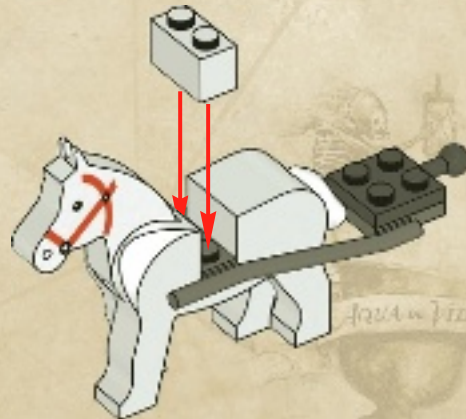

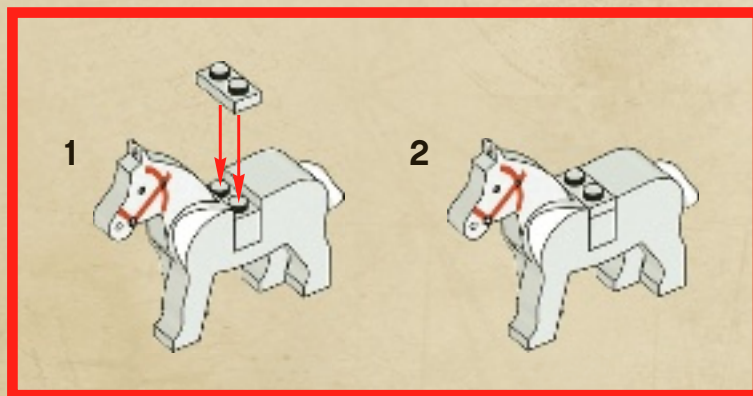
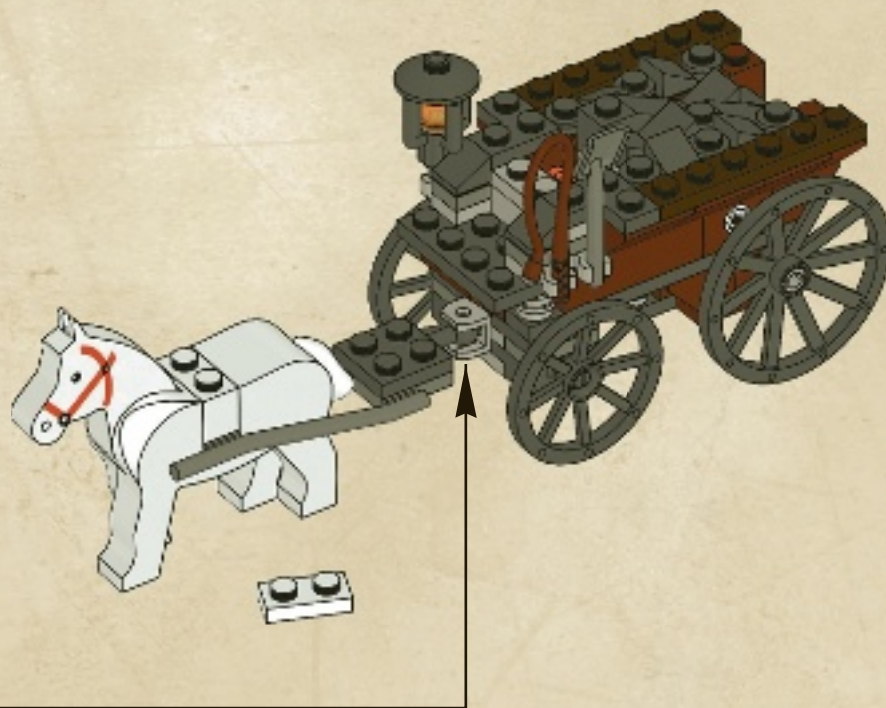



PIRATES OF THE CARIBBEAN

ON STRANGER TIDES





www.LEGOclub.com



LEGO® Club Email

LEGO club™

FREE! GRATIS! GRATUIT!



LEGO® Club Magazine

SIGN UP ONLINE!

www.LEGOclub.com



00800 5346 5555*



1-866-534-6258 • 1-877-518-5346

US & Canada only

Canada seulement

* Freephone. Mobile charges may apply.
* Numéro sans frais. Des frais peuvent s'appliquer avec les téléphones cellulaires.
* Gebührenfrei, Kosten für Anrufe aus Mobilfunknetzen können abweichen.
* Gratis telefonnummer vanaf vaste lijn.
* Det er et gratis nummer, når du ringer fra fasttelefon.
* Det är gratis, när du ringer från en fast telefon.
* Numéro sans frais. Des frais peuvent s'appliquer avec les téléphones portables.



WIN!

Go to www.LEGOsurvey.com/product to fill out a survey for a chance to win a cool LEGO® Product. No purchase necessary. Open to all residents where not prohibited.

 www.LEGO.com



www.LEGOsurvey.com/product

GEWINNE! WIN!

Nimm an der Umfrage auf www.LEGOsurvey.com/product teil und hab die Chance ein cooles LEGO® Produkt zu gewinnen!
Die Teilnahme am Gewinnspiel führt zu keinerlei Kaufverpflichtungen. Teilnahme in allen nicht ausgeschlossenen Ländern möglich.

Ga naar www.LEGOsurvey.com/product, vul een enquêteformulier in en maak kans op een cool LEGO® product.
Geen aankoopverplichting. Iedereen mag deelnemen, uitgezonderd ingezetenden van landen waar een enquêteverbod geldt.

GAGNE! 当てよう!

Visite www.LEGOsurvey.com/product pour répondre à un questionnaire et avoir une chance de gagner un produit LEGO® très cool!
Aucune obligation d'achat. Ouvert à tous les résidents des pays autorisés.

www.LEGOsurvey.com/product にアクセスして、アンケートにご記入ください。当選者にはレゴ®製品を差し上げます。
お買い上げの必要はありません。
禁止されていない限り、すべての皆様にご利用いただけます。