

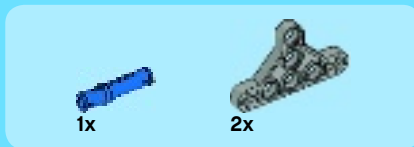

TECHNIC

9393

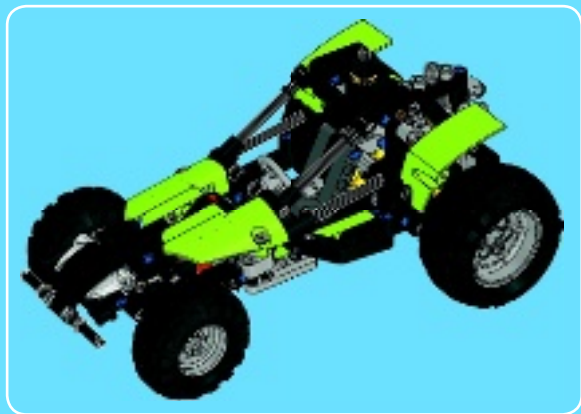



1

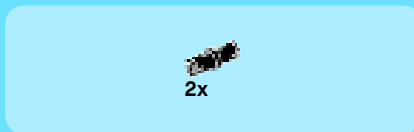
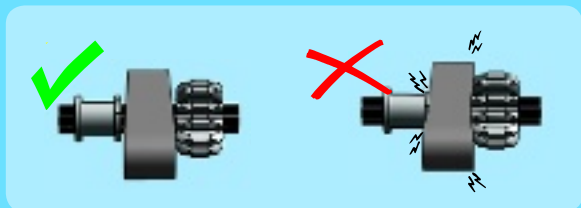
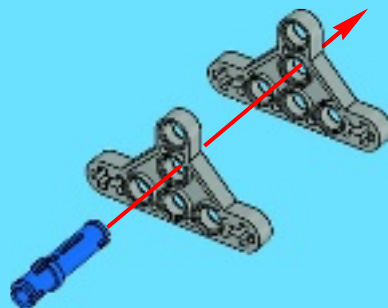

2

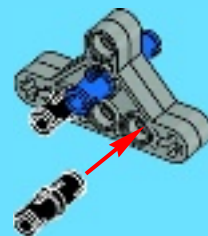



3

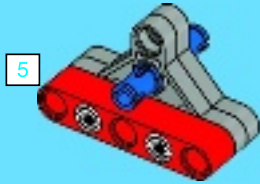

4

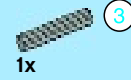
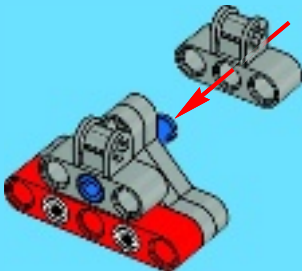

5

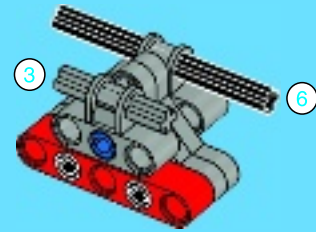

1:1

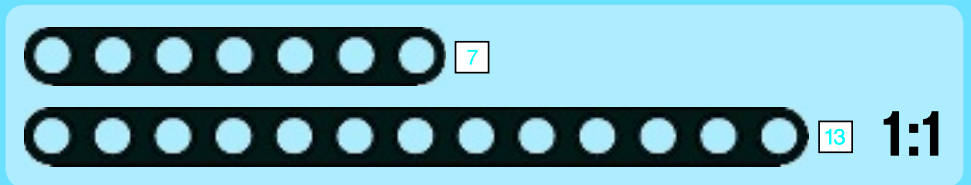
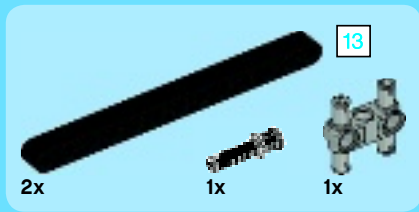

6

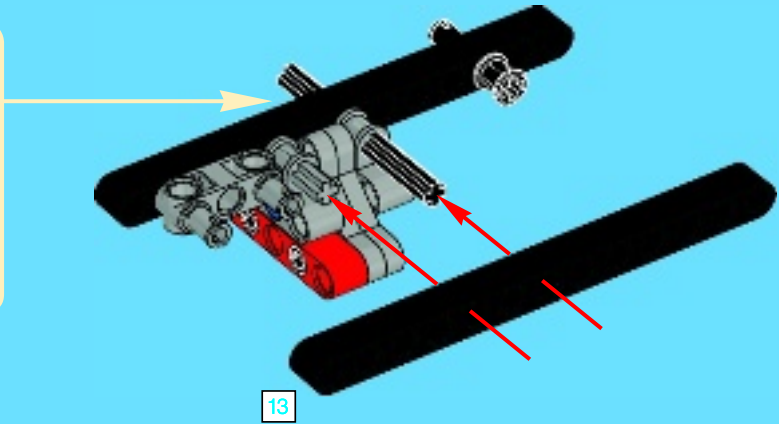
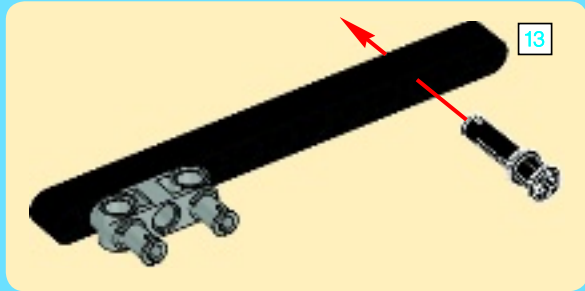

7

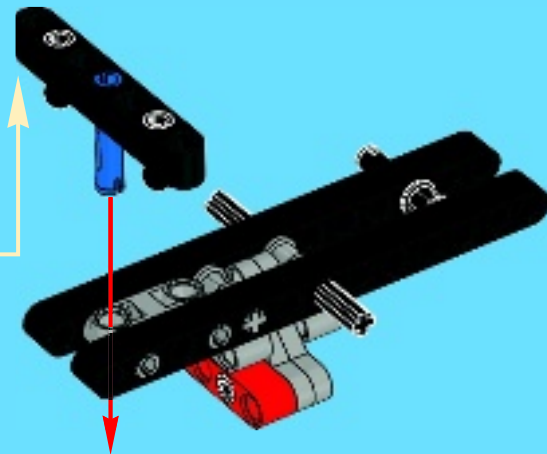
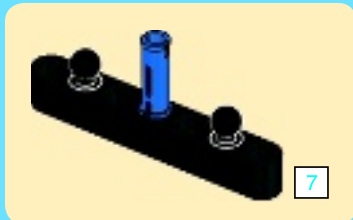

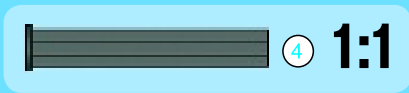
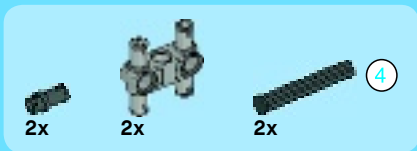

8

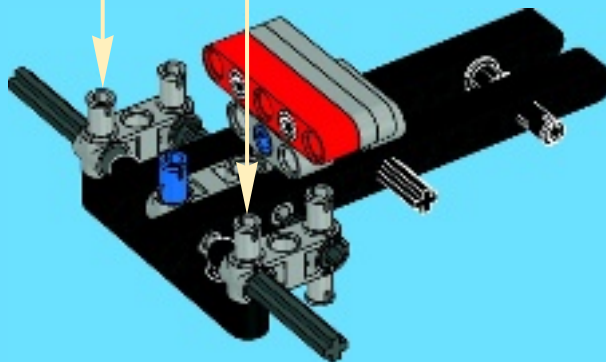
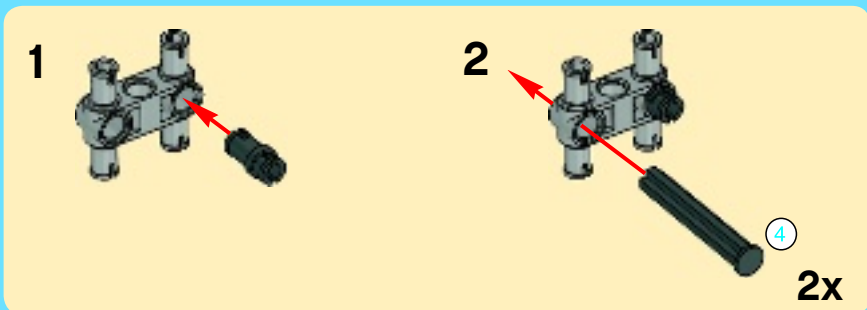



1x

9

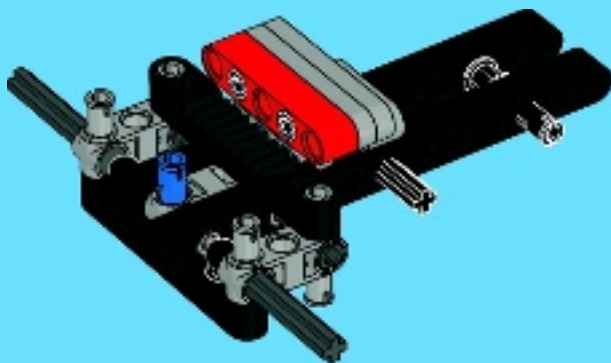

3x

10

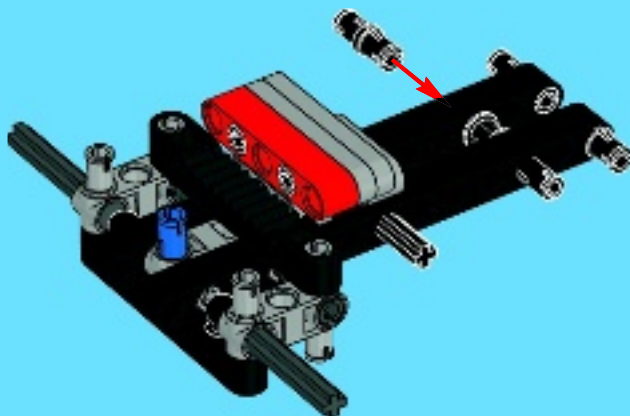

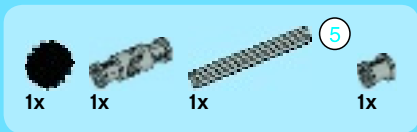

11

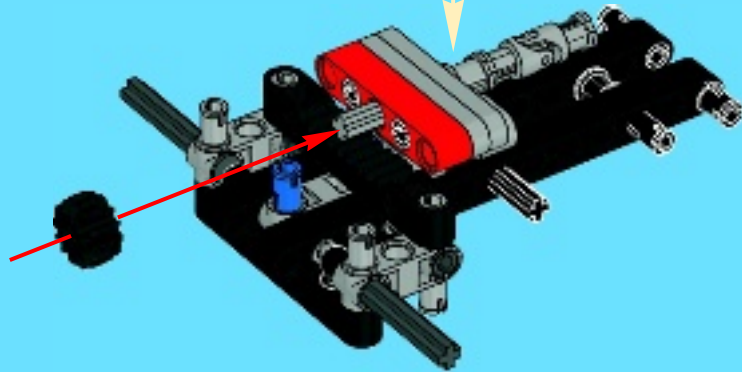
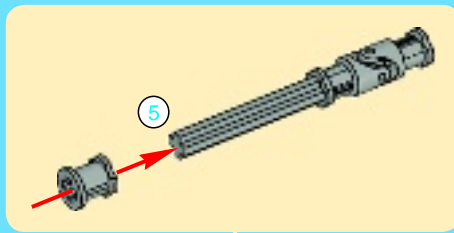

12

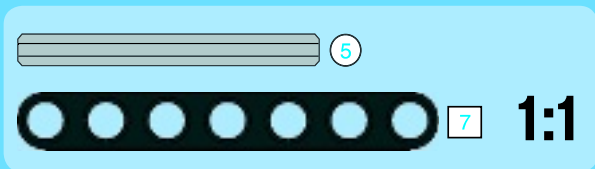
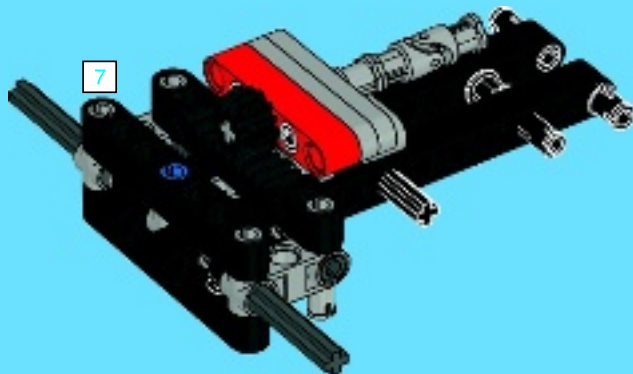

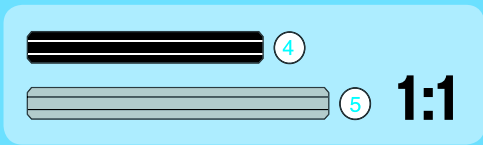
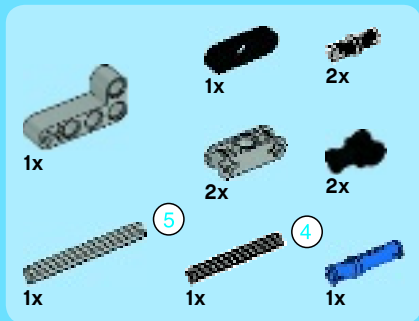

13

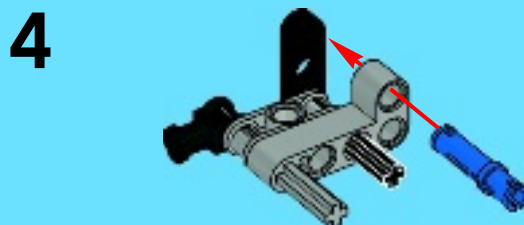
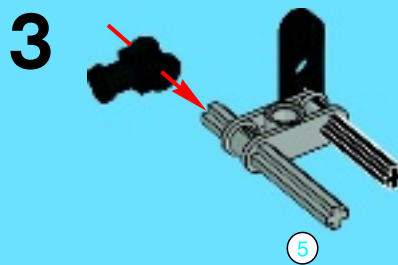
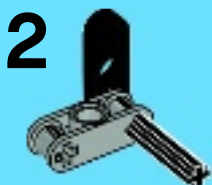

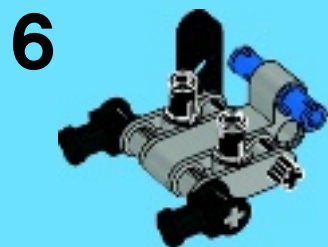
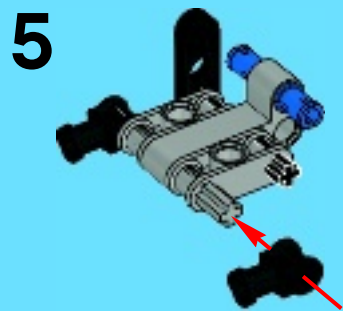

7

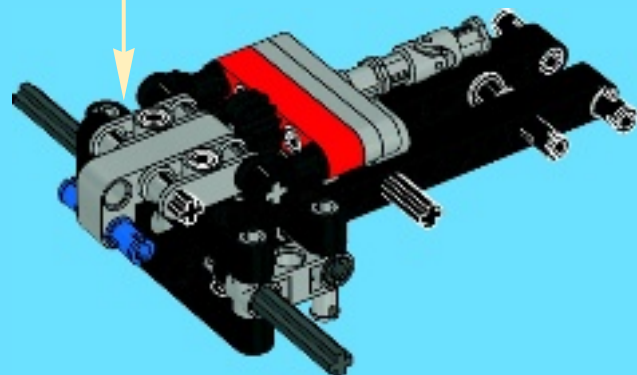

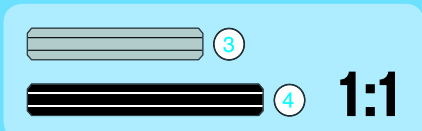
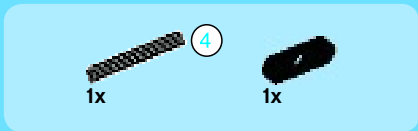

14

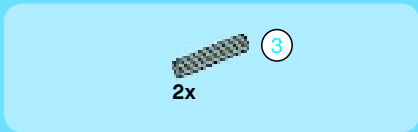
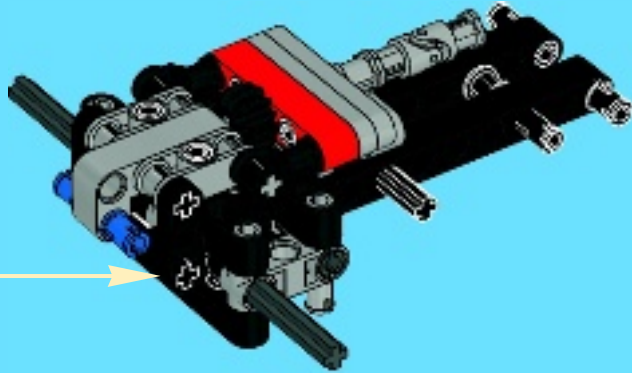
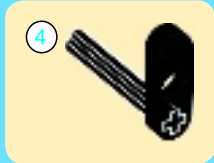

15

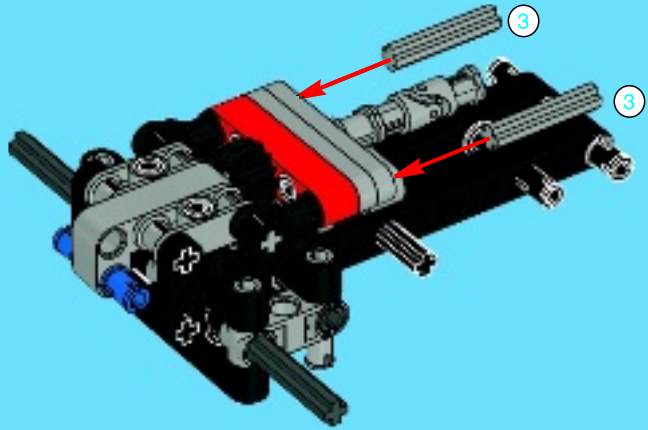

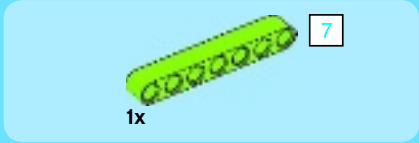
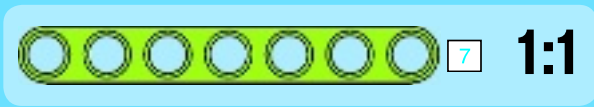

1

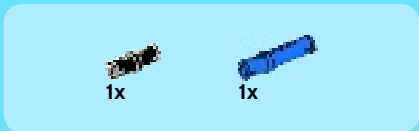
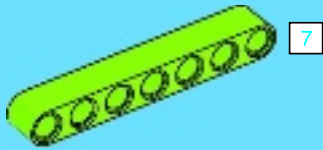

2

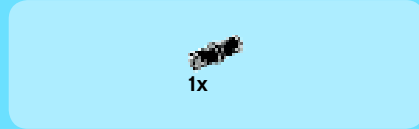
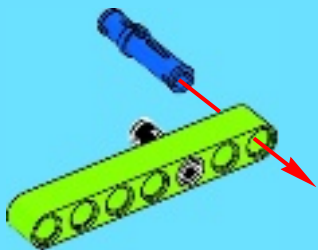

3

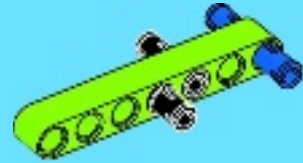

4

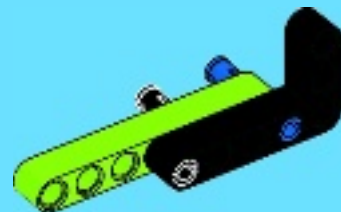

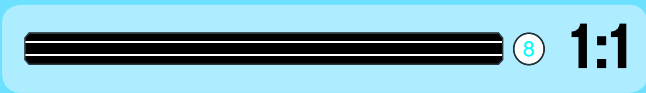
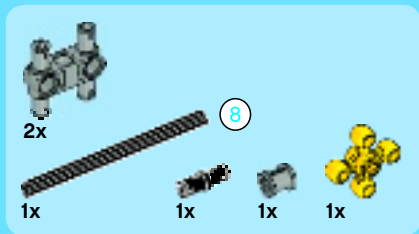

5

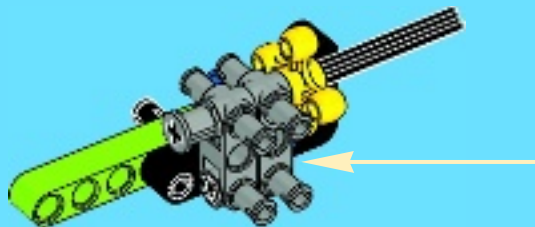
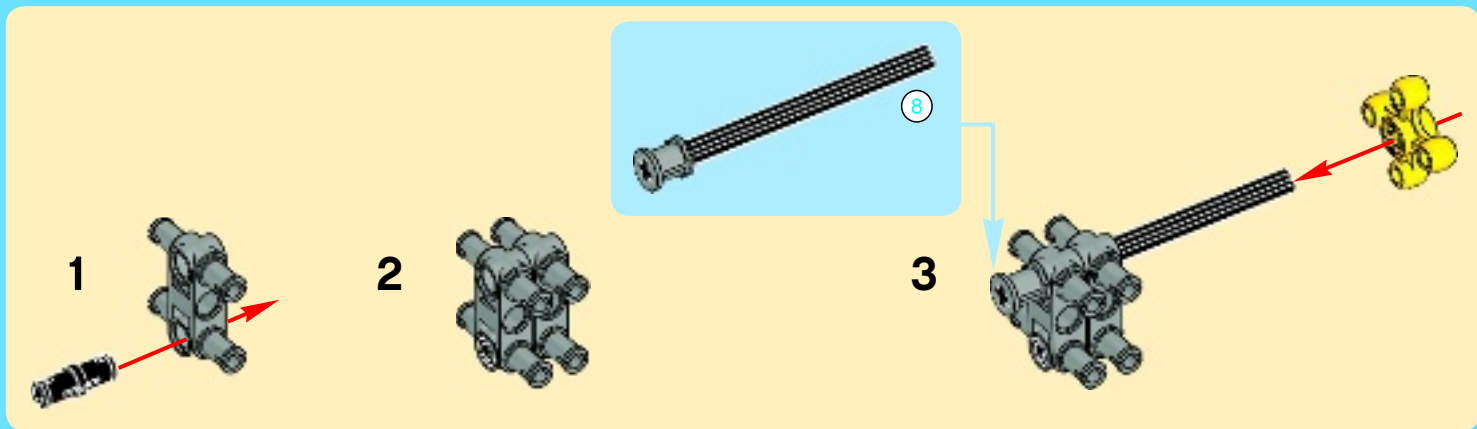

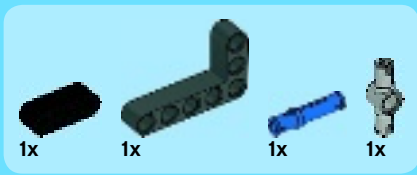

6

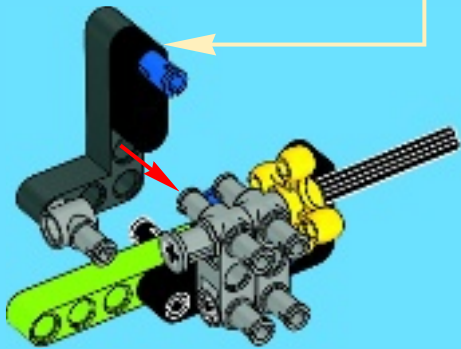
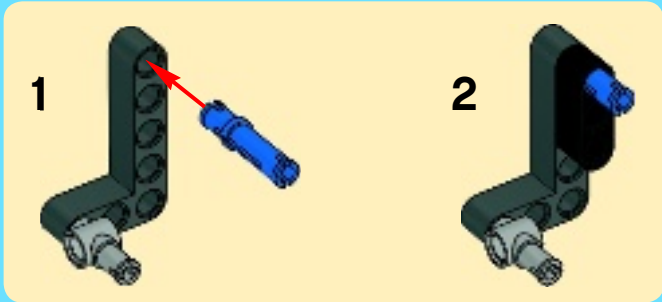

7

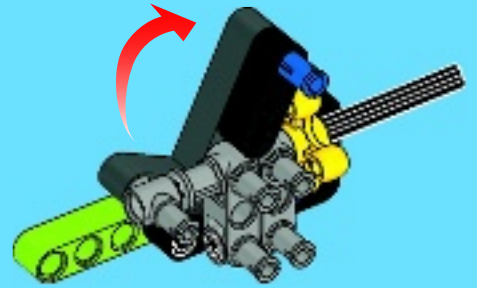

8

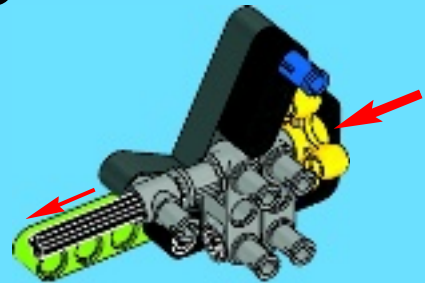

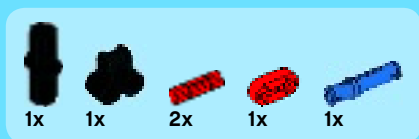

9

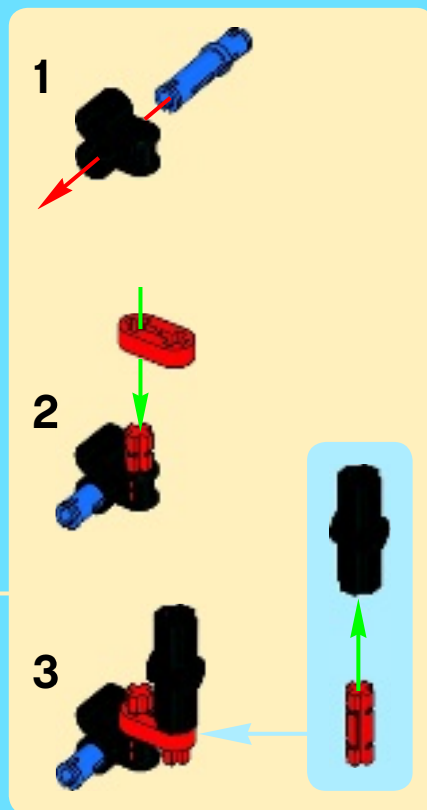
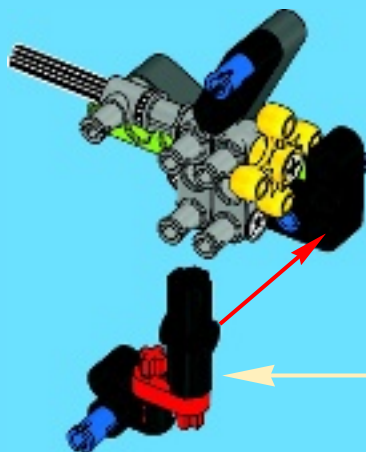

10



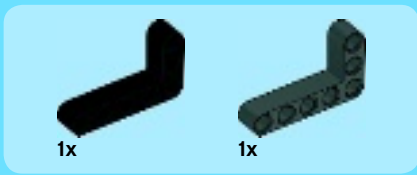

11



16

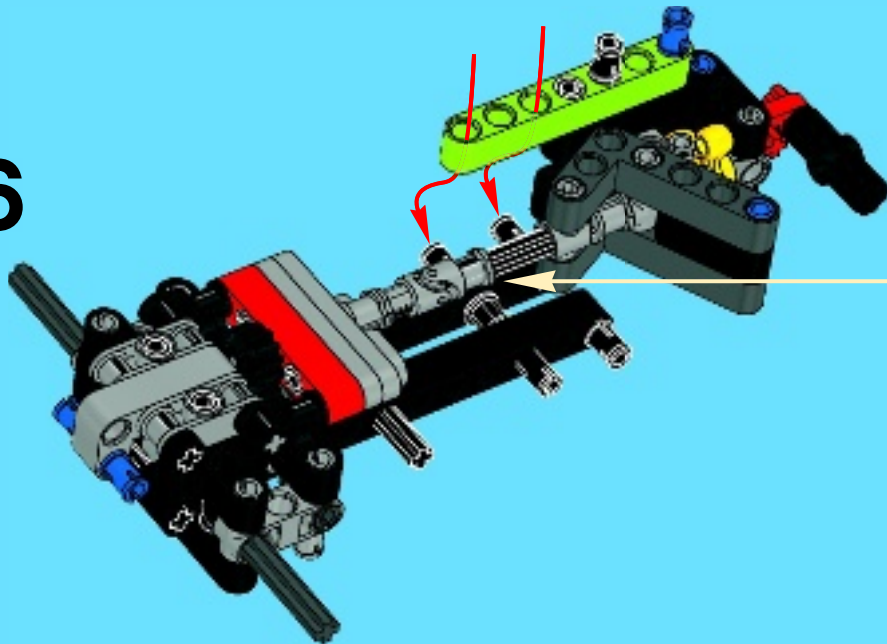



1x



1x

17

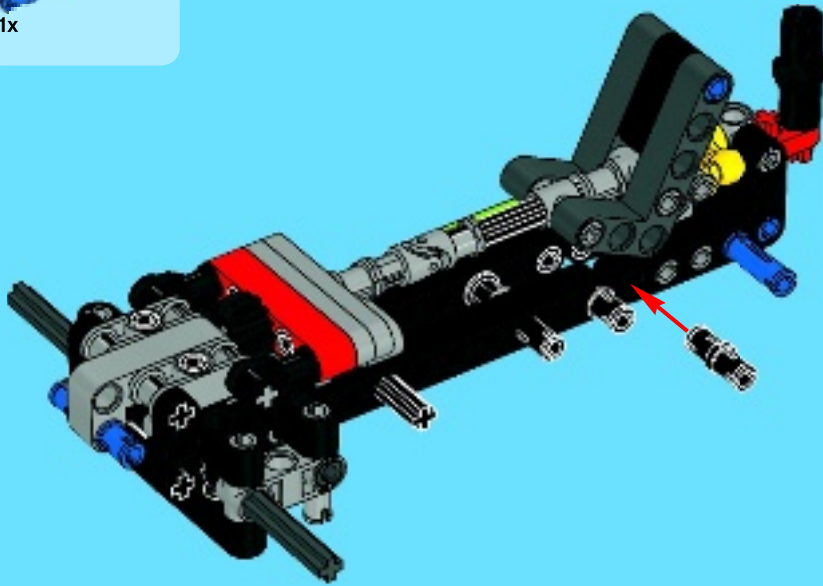

1x



1x

7

18

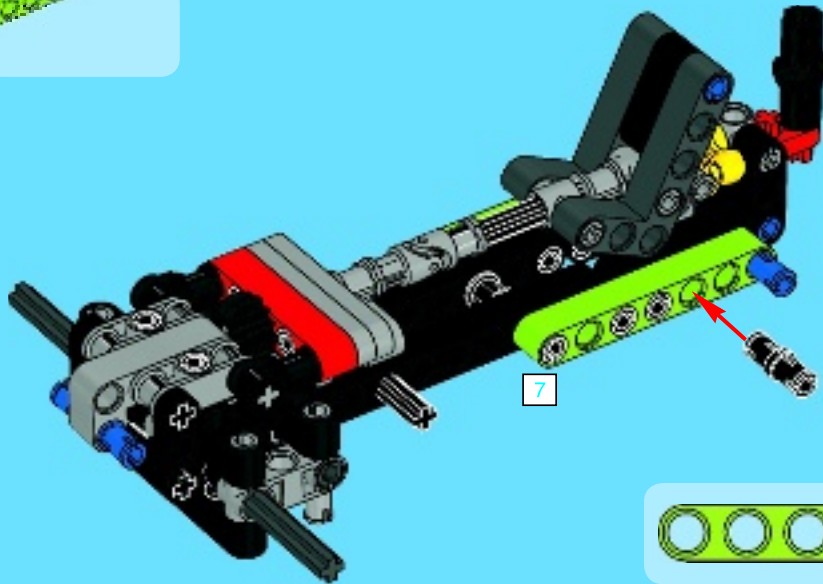

7



7

1:1

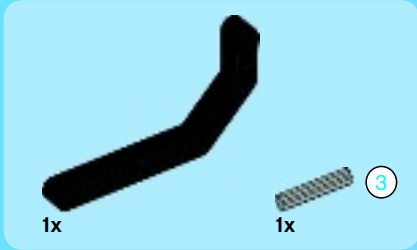

1

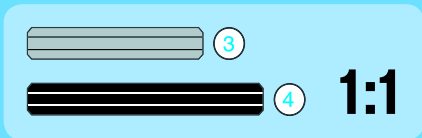
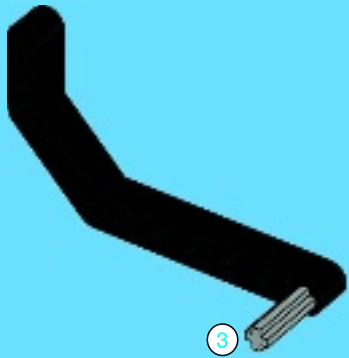

2

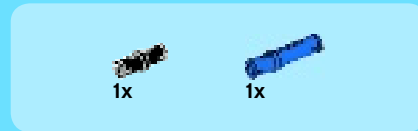
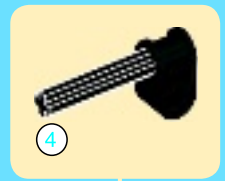
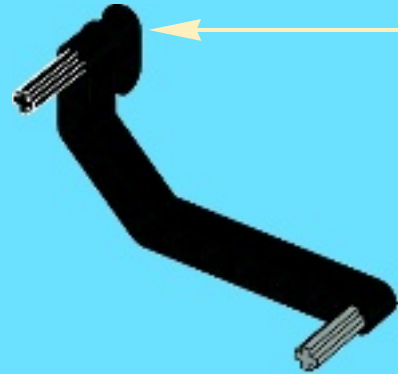

3

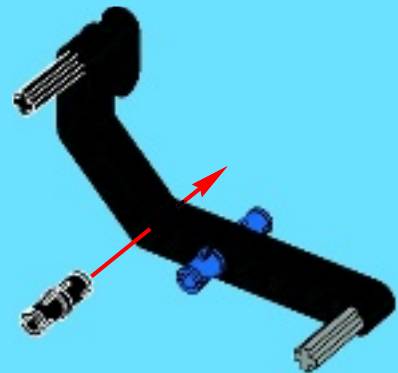

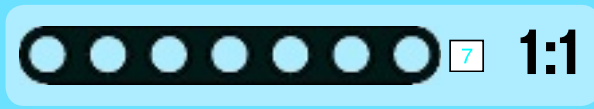

4

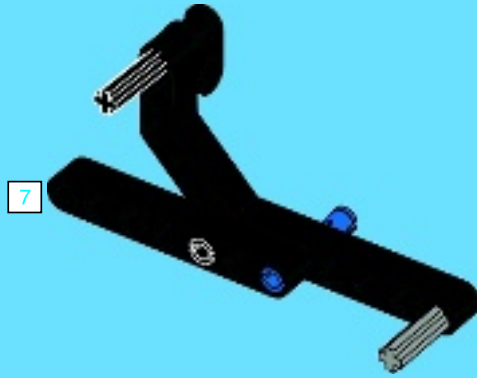

5

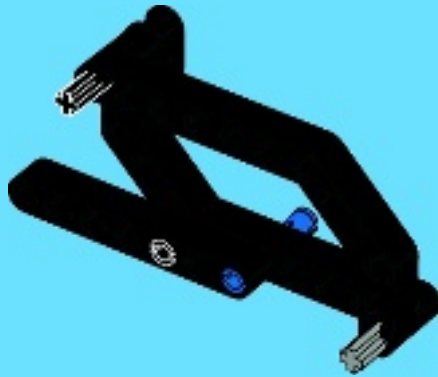

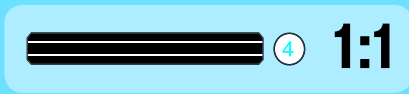
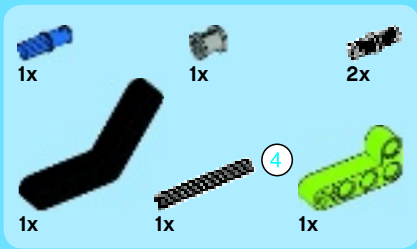

6

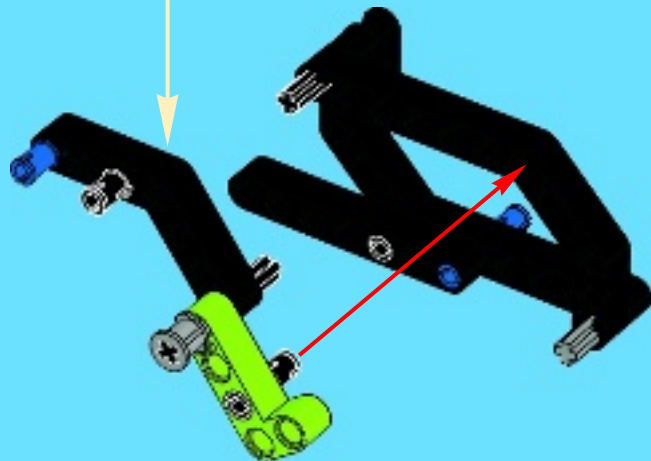
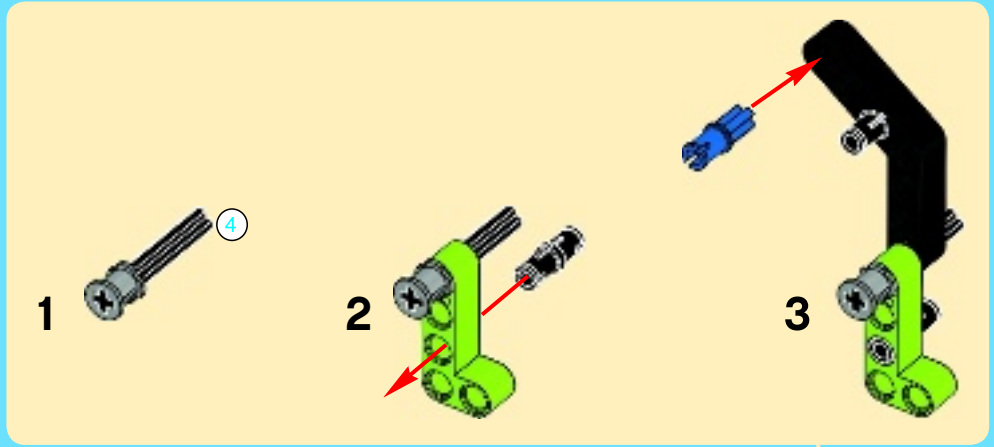

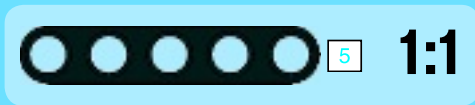

7

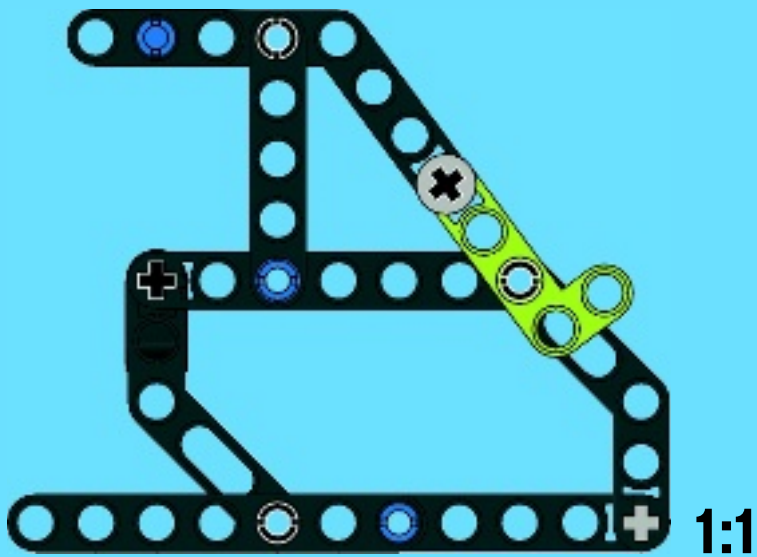
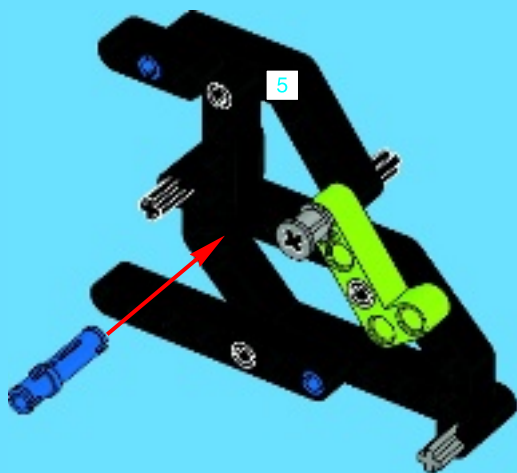

19

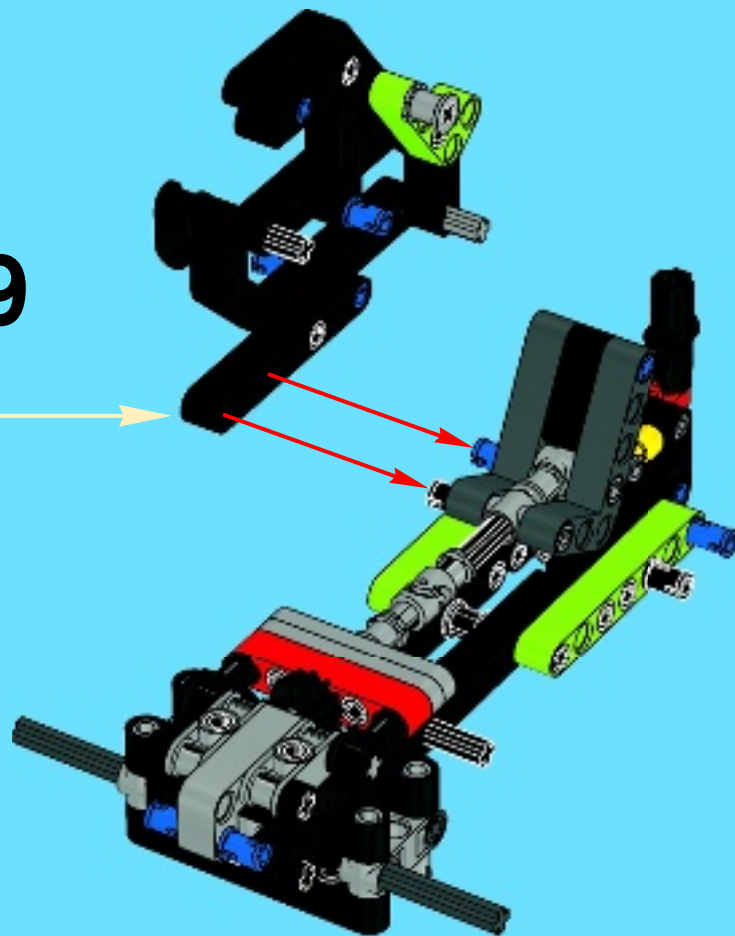

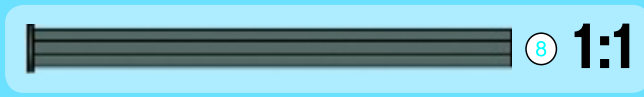
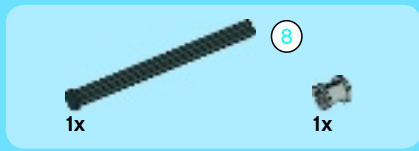

20

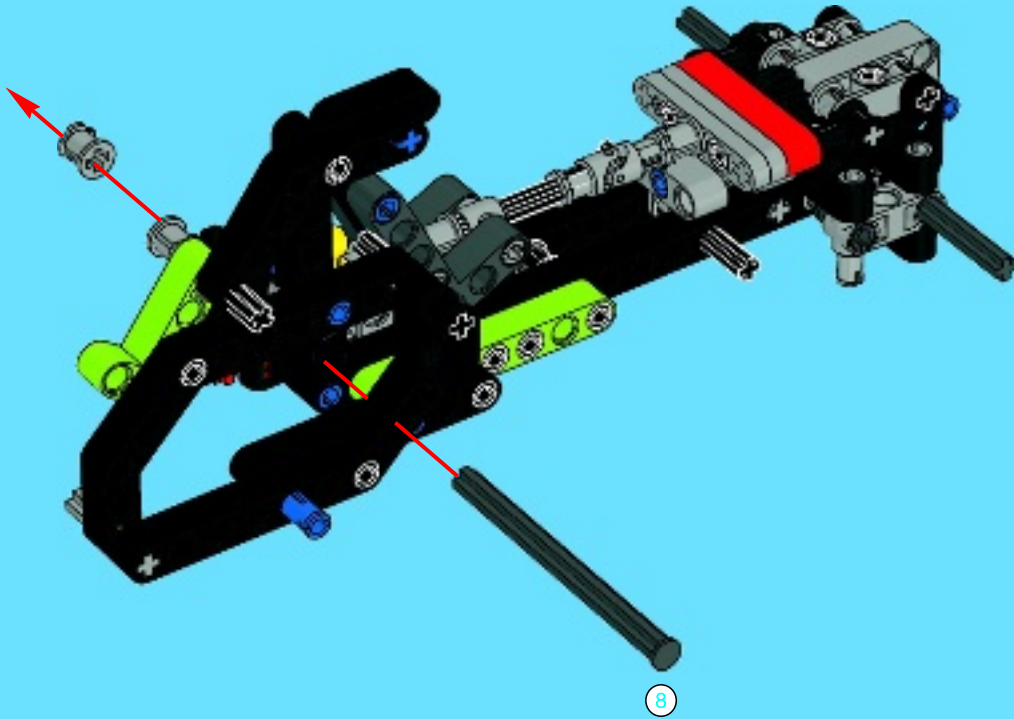

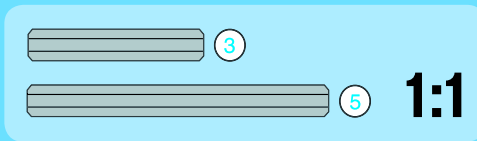
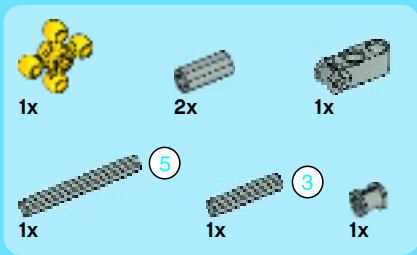

21

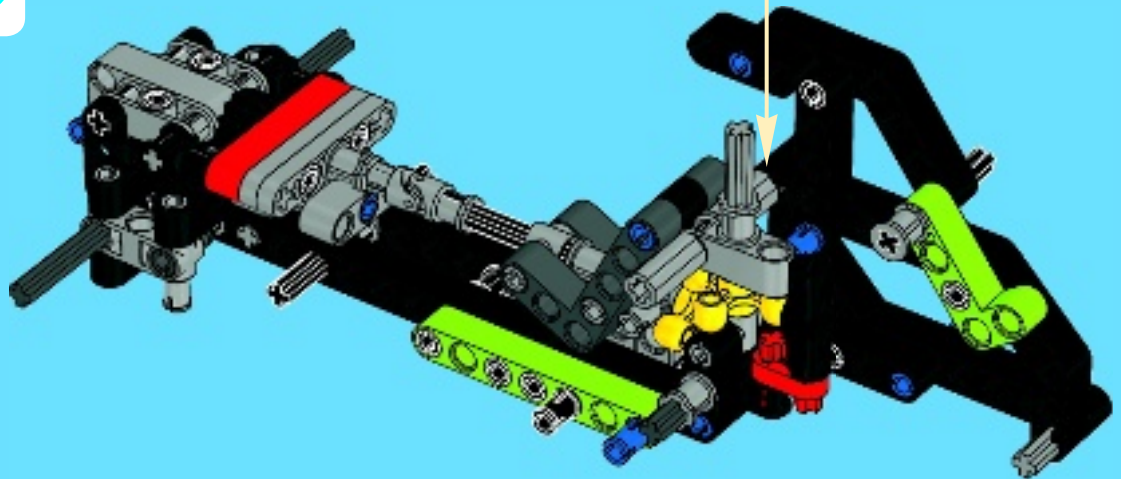
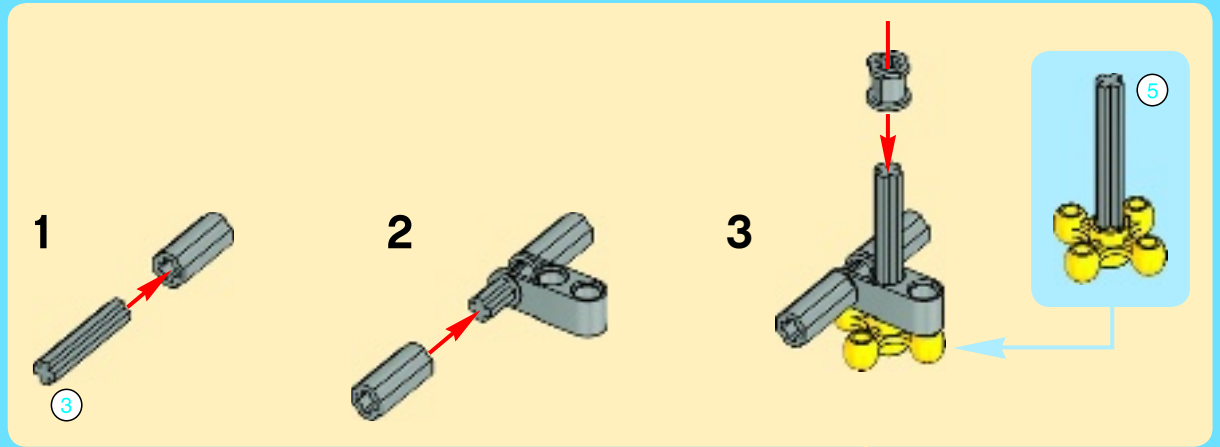



1x

22

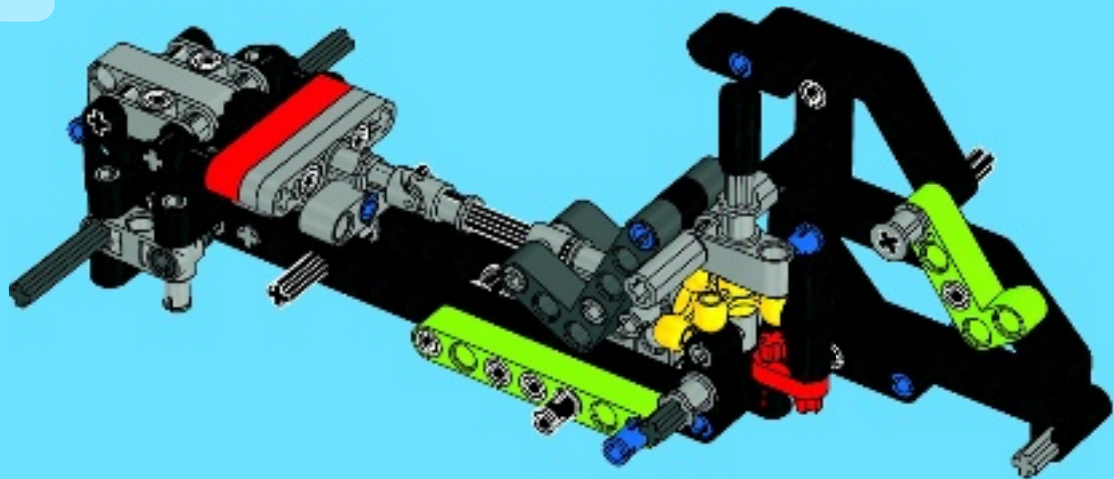

1x

23

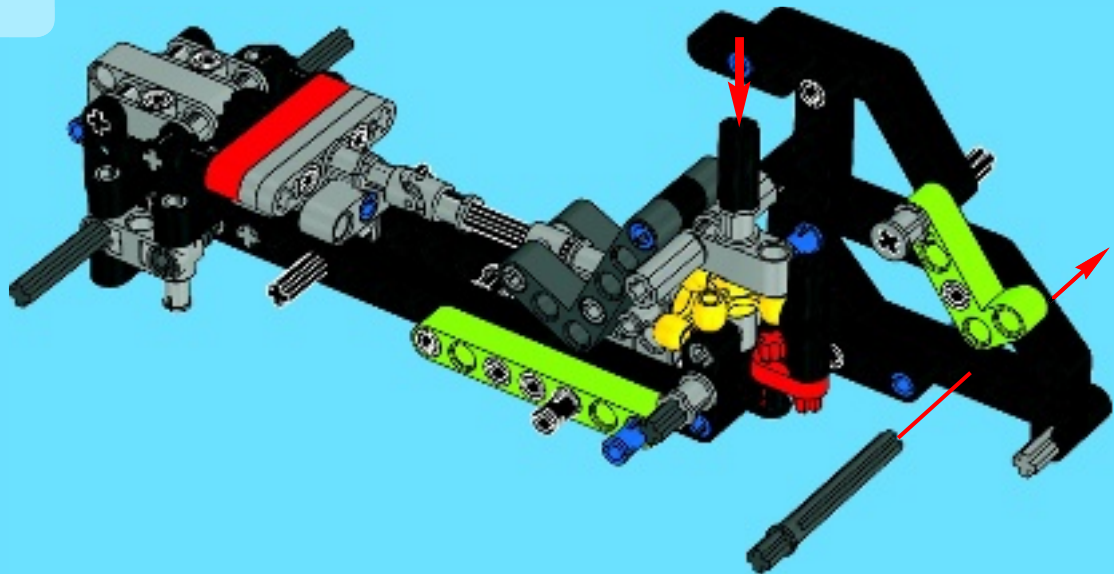

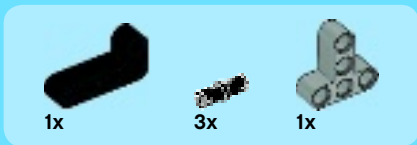

24

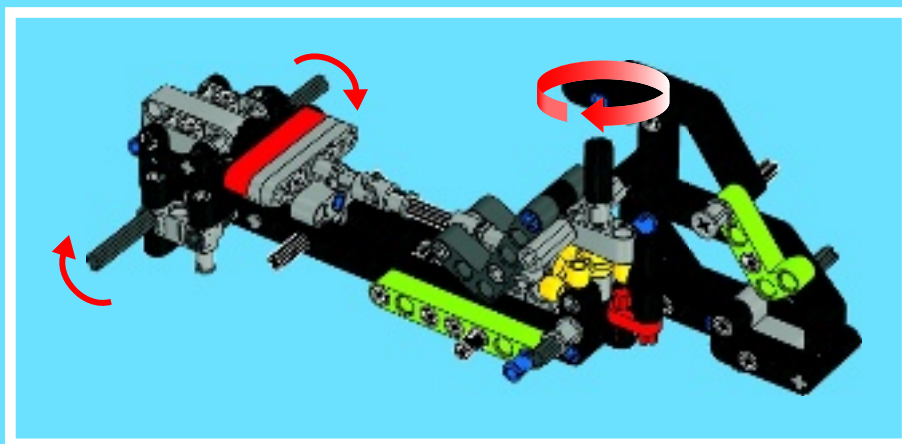
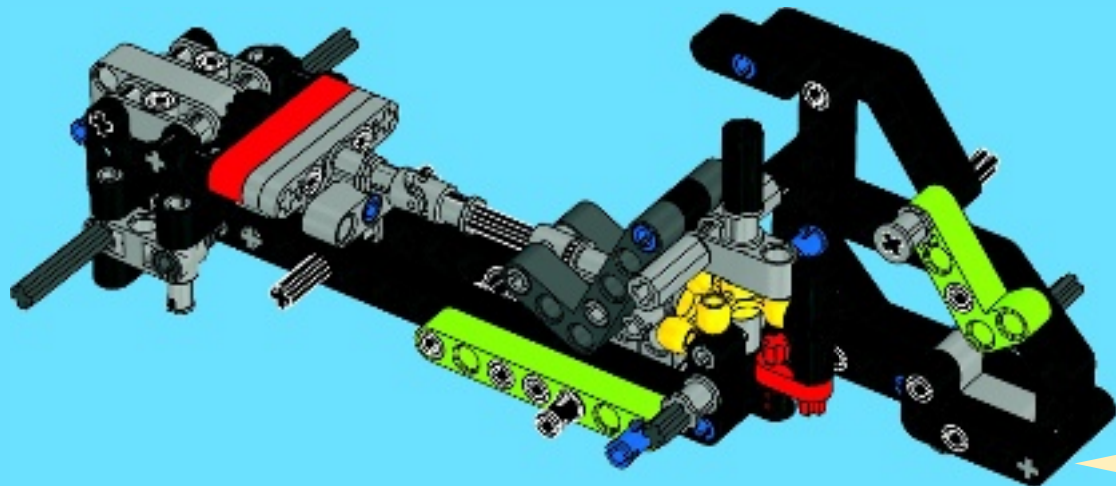
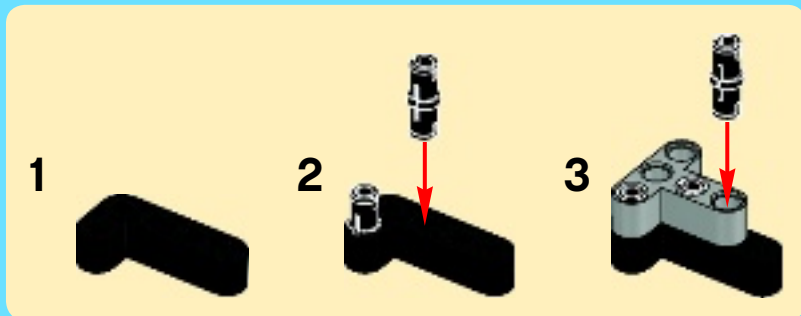

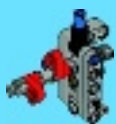

1

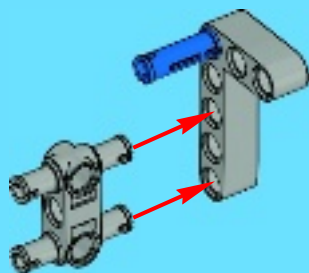

2

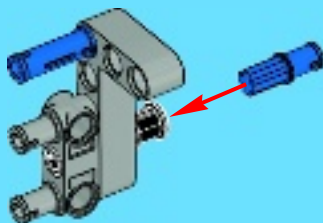

3

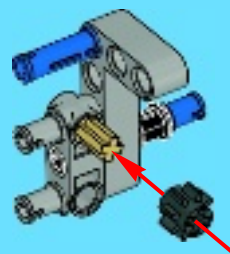

4

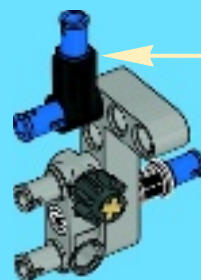
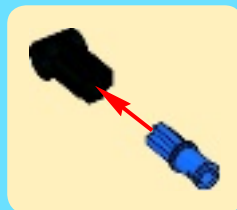

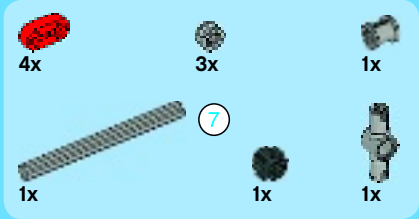
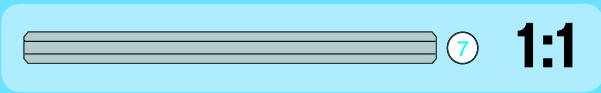

5

1

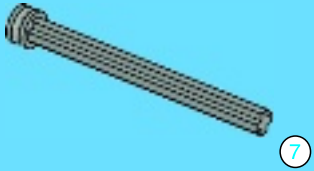

2

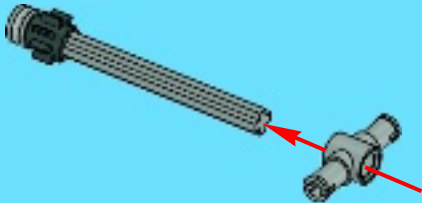

3

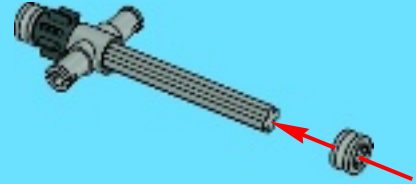

4

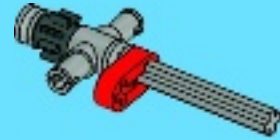

5

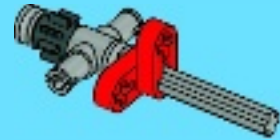

6

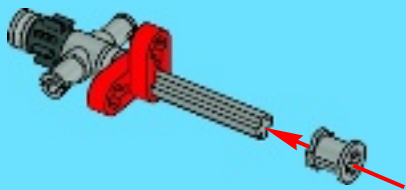

7

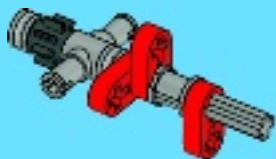

8

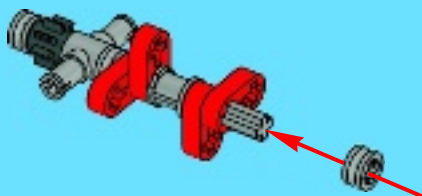

9

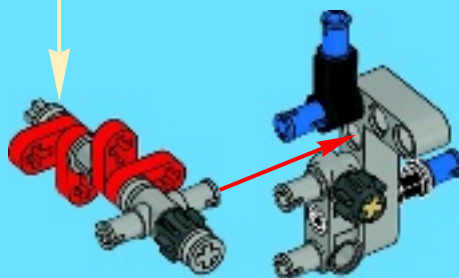
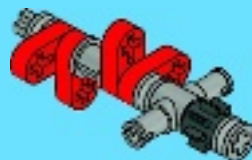



2x

10

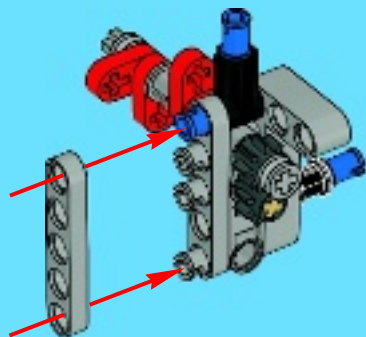

1x

11

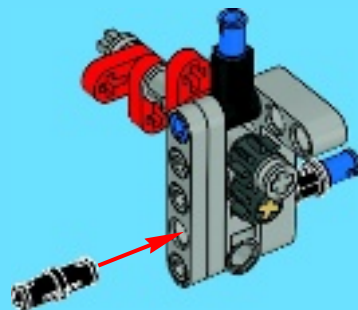

25

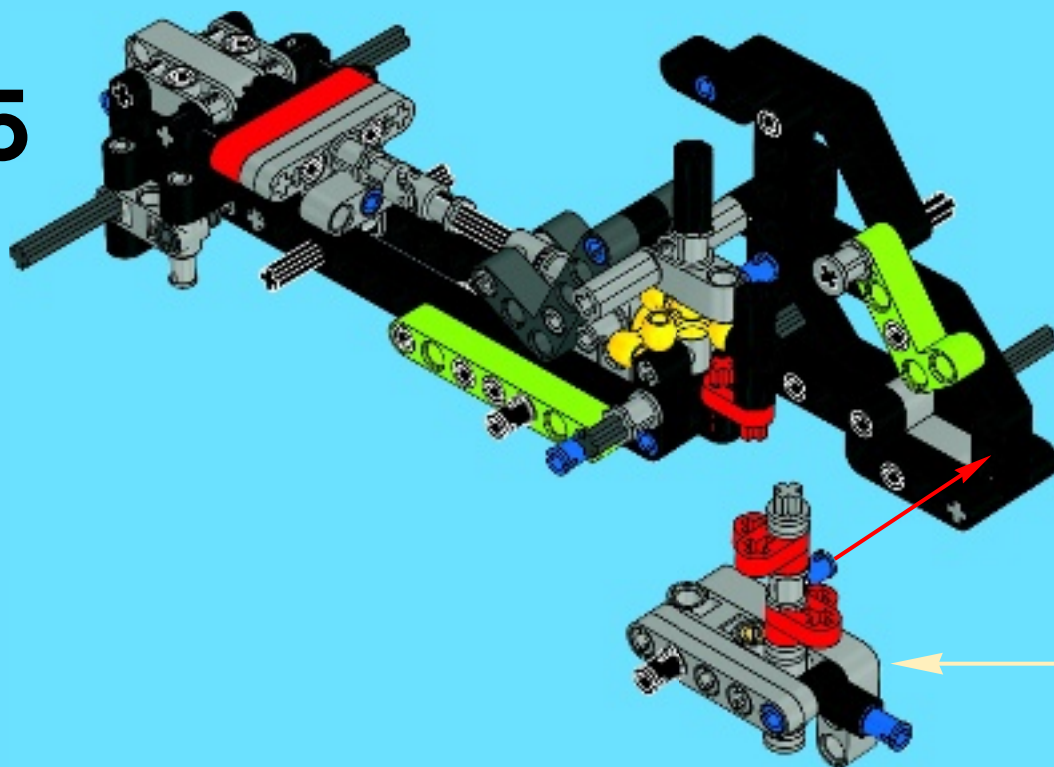

26

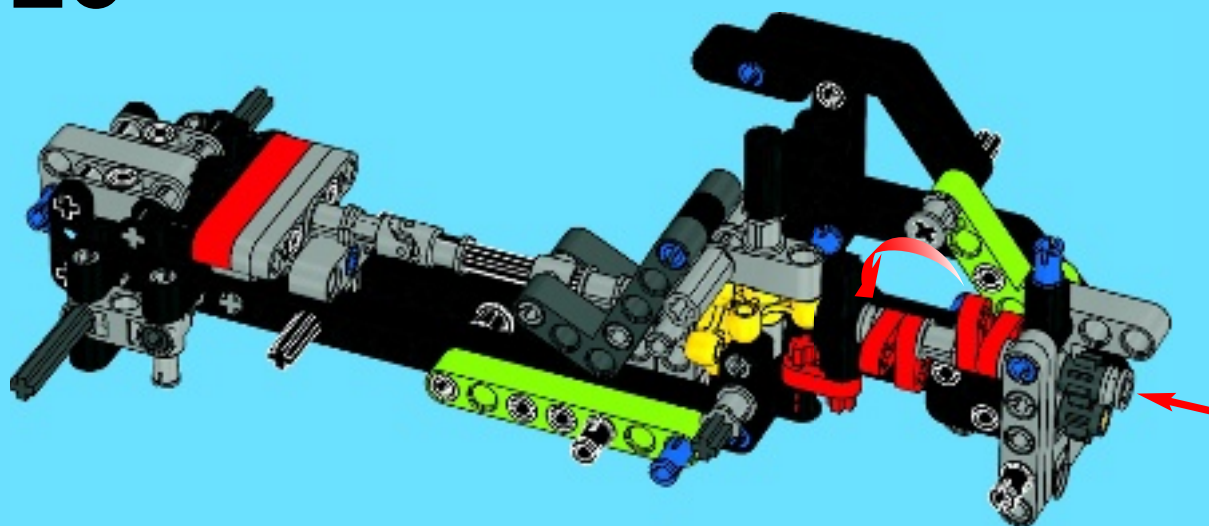

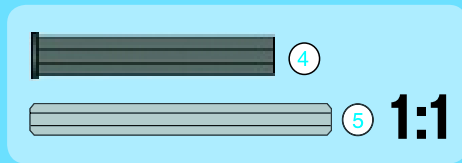
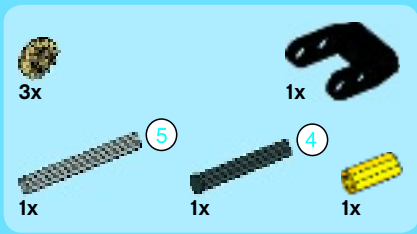

27

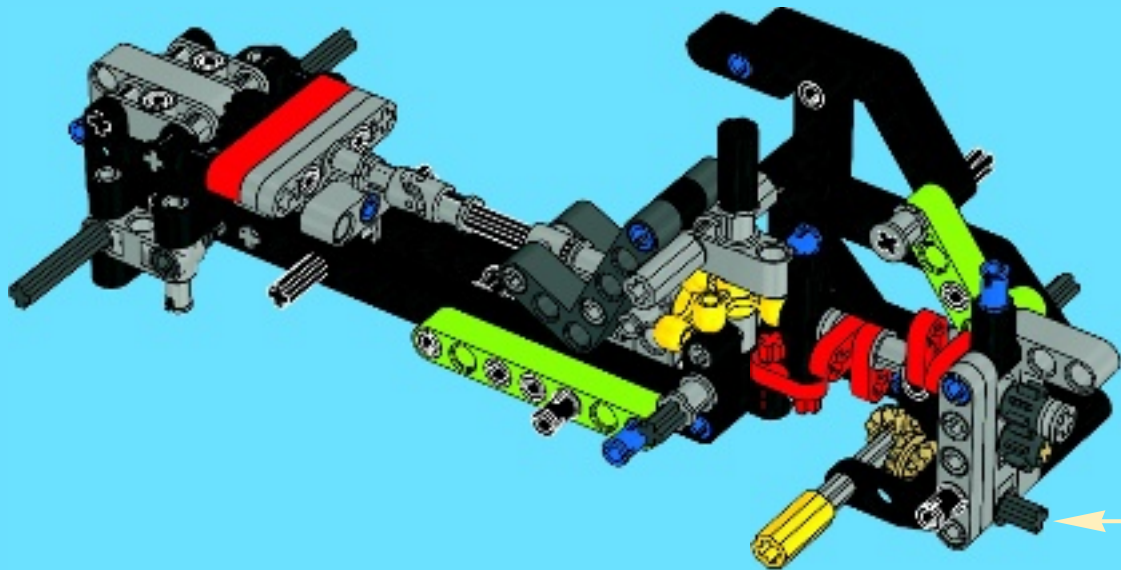
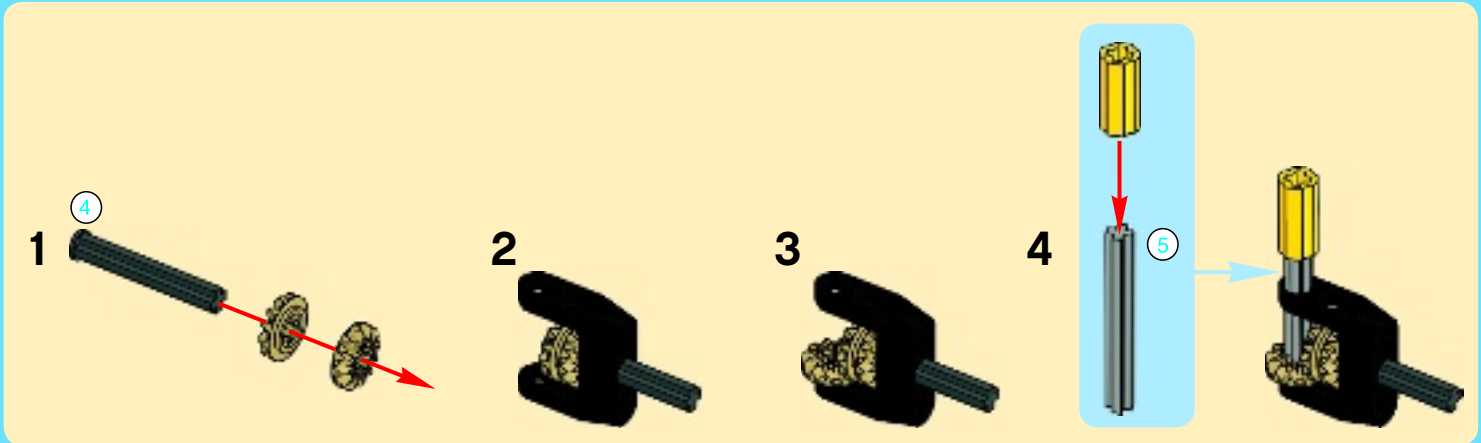



1x

28

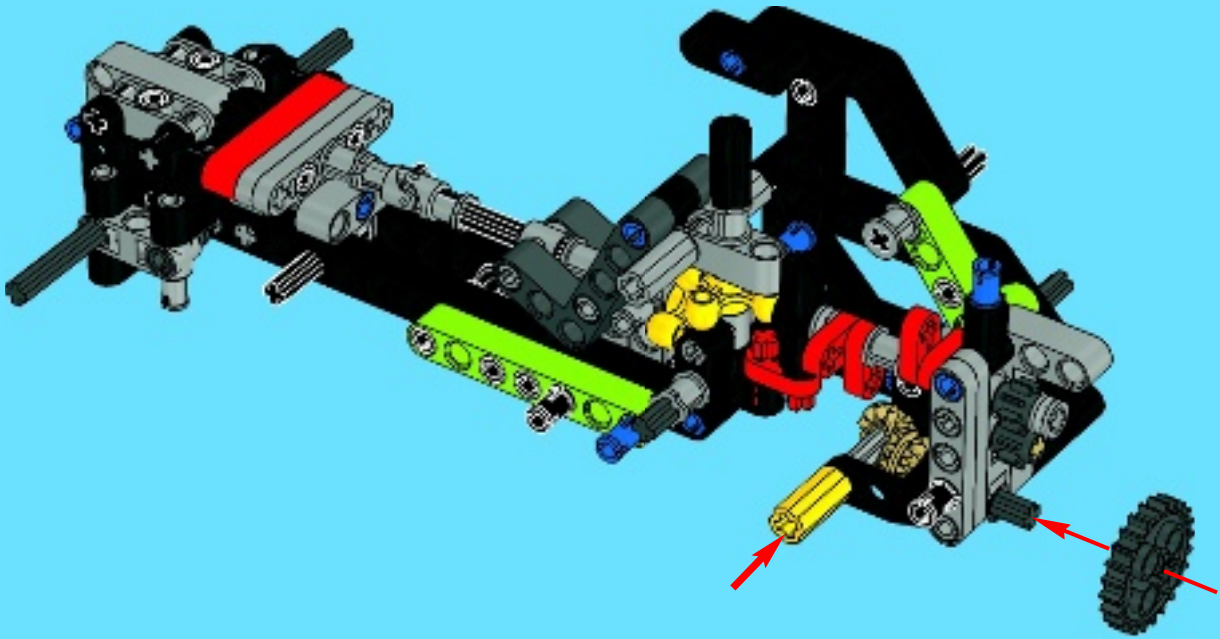



1

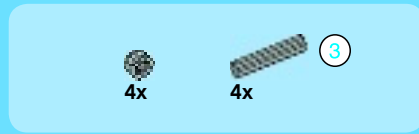
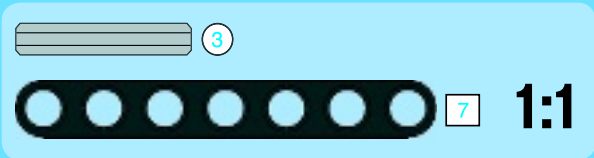

2

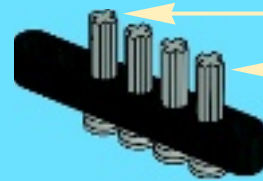
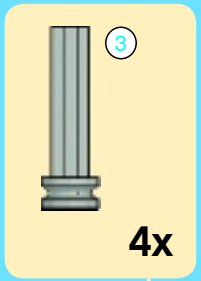

3





1x



1x

4

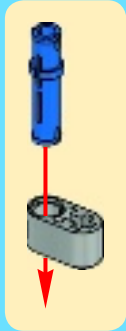

5



1x

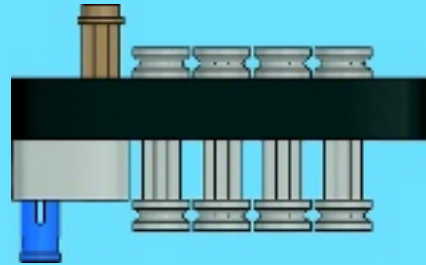

1:1

29

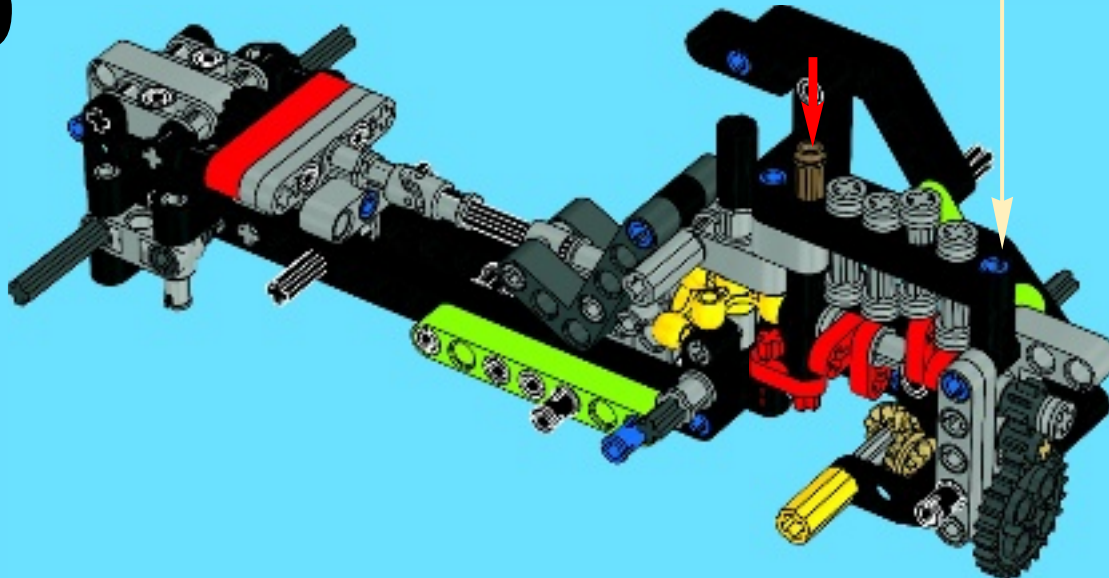

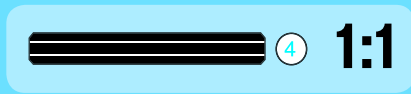
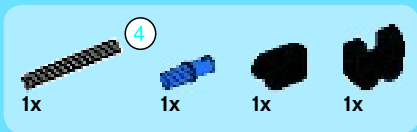

30

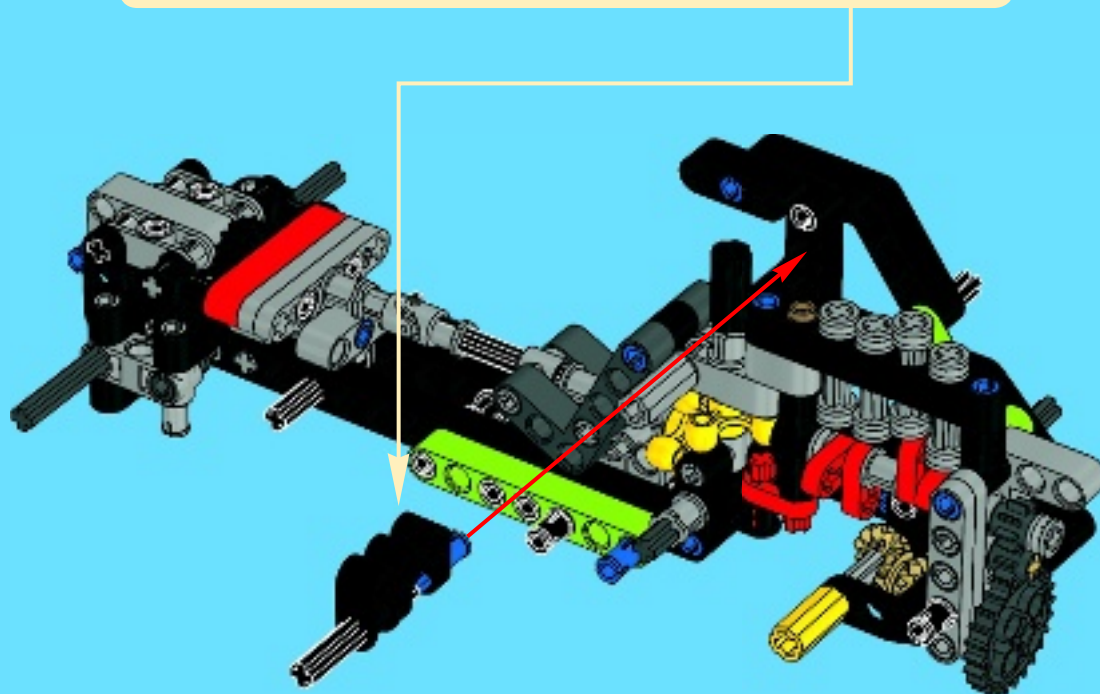
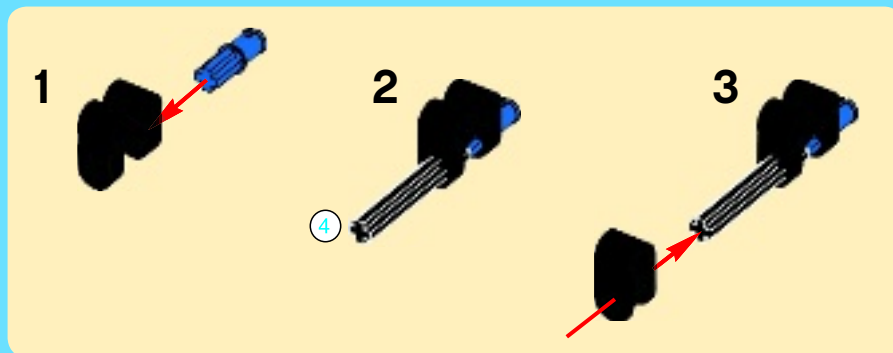



1x



1x

31

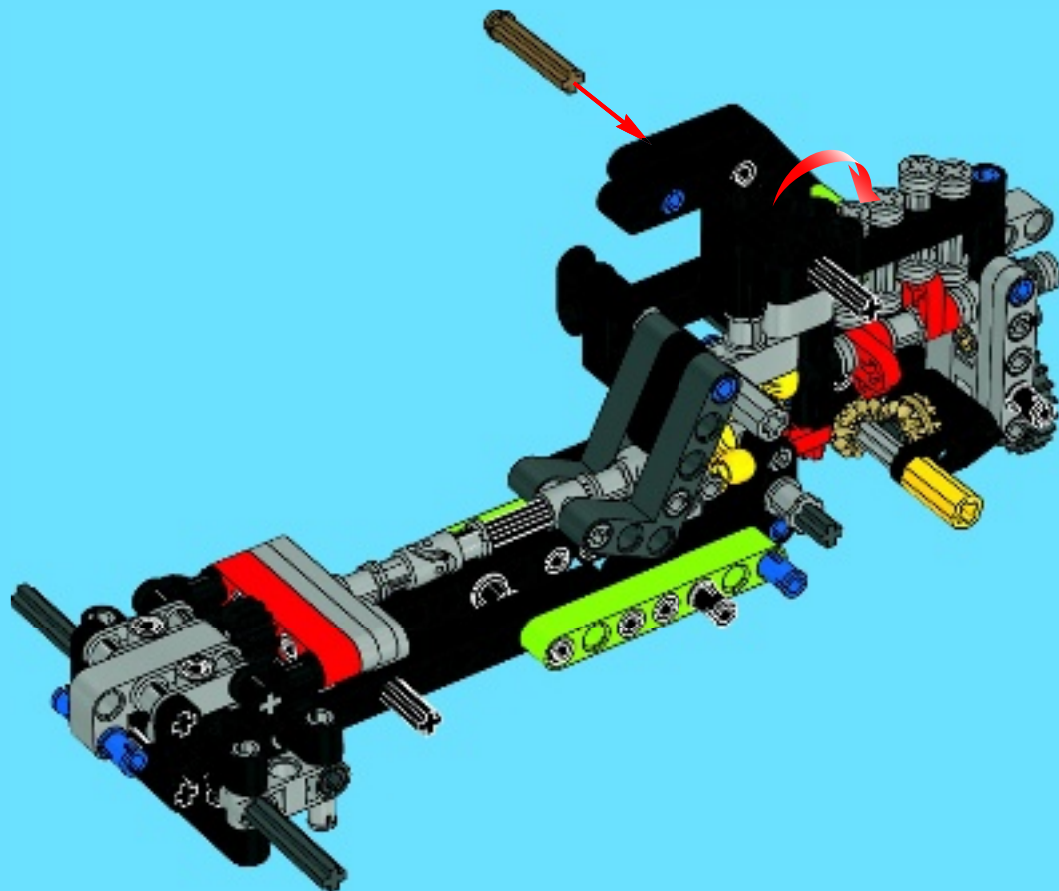

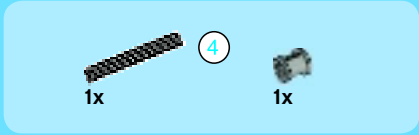

1

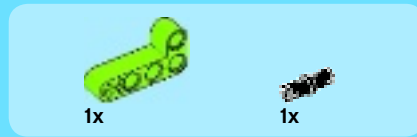

2



3



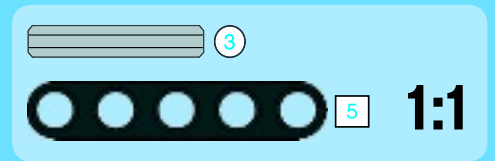
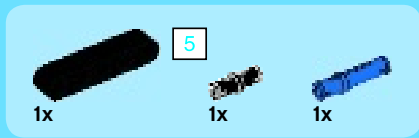

4

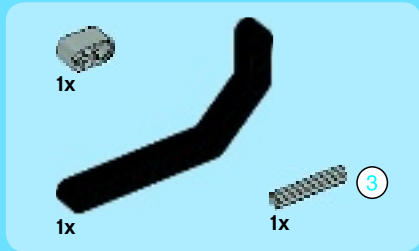
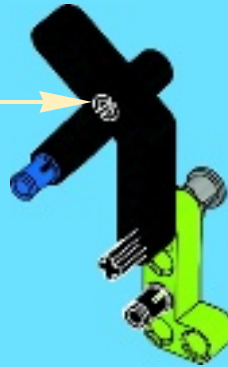
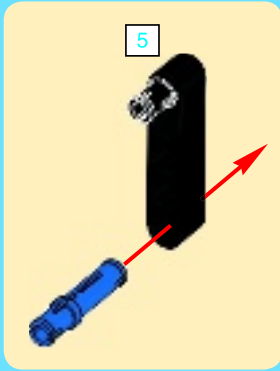

5

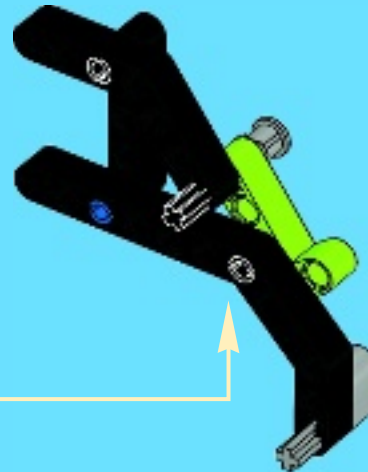
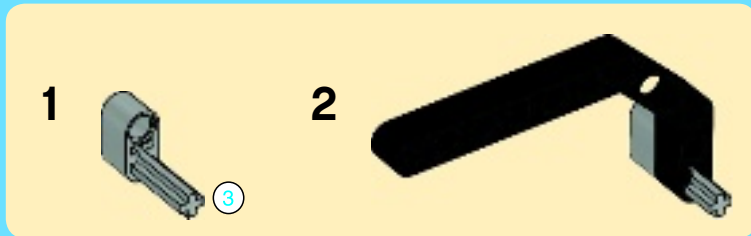



1x

6

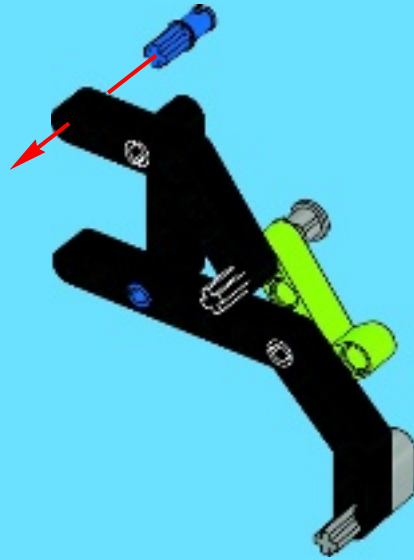

1x

7

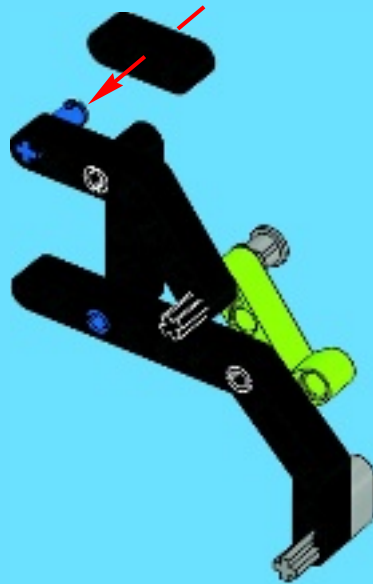

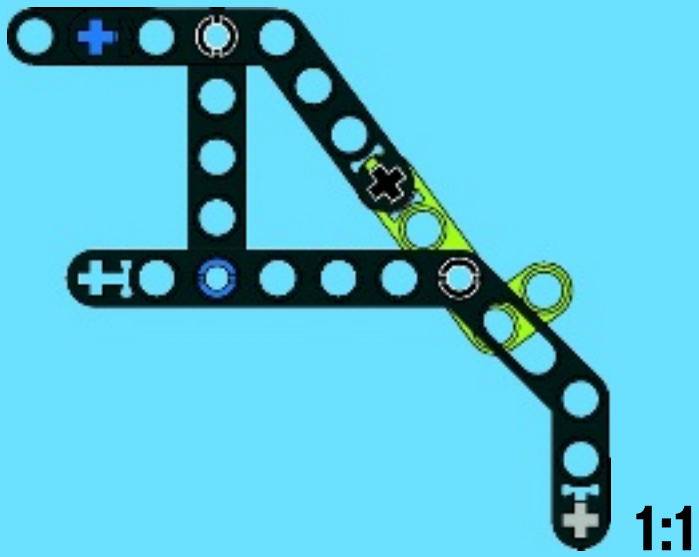

32

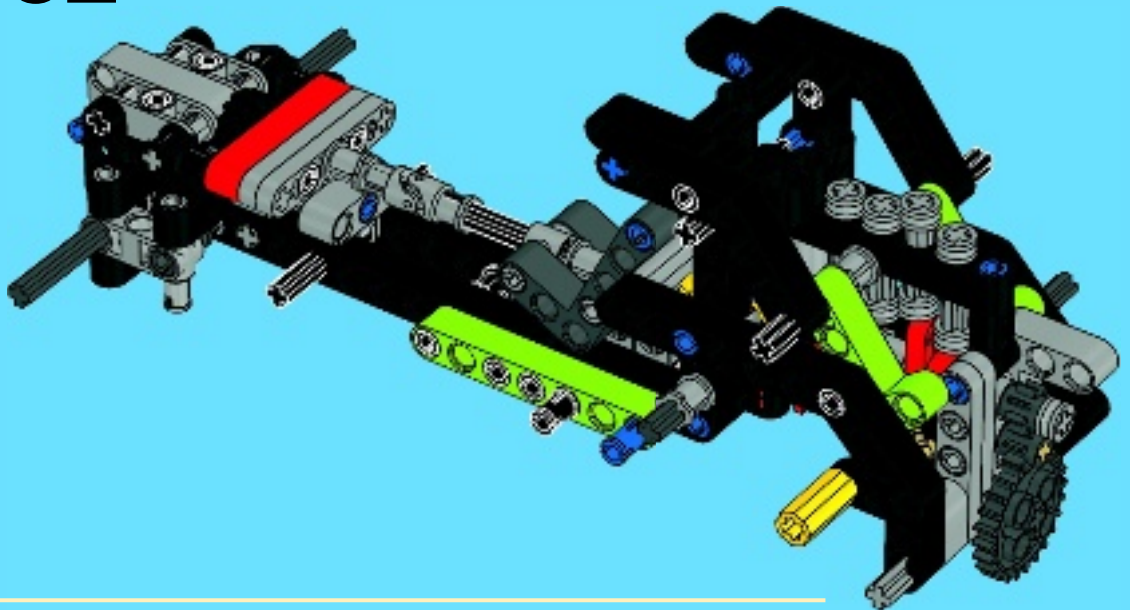



1x



1x

33

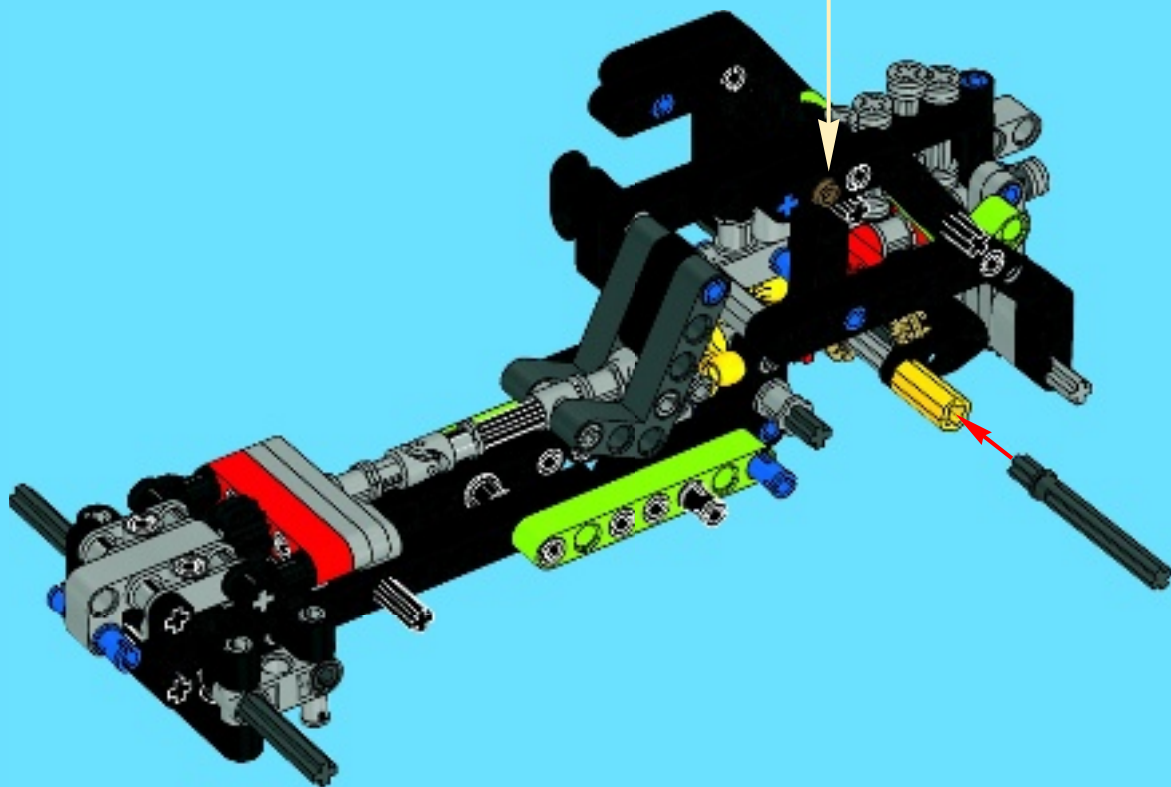

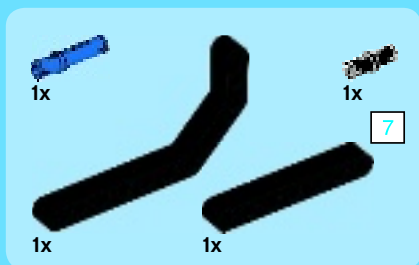

34

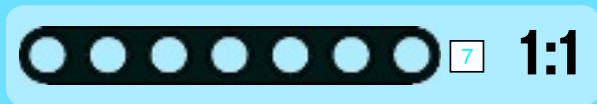
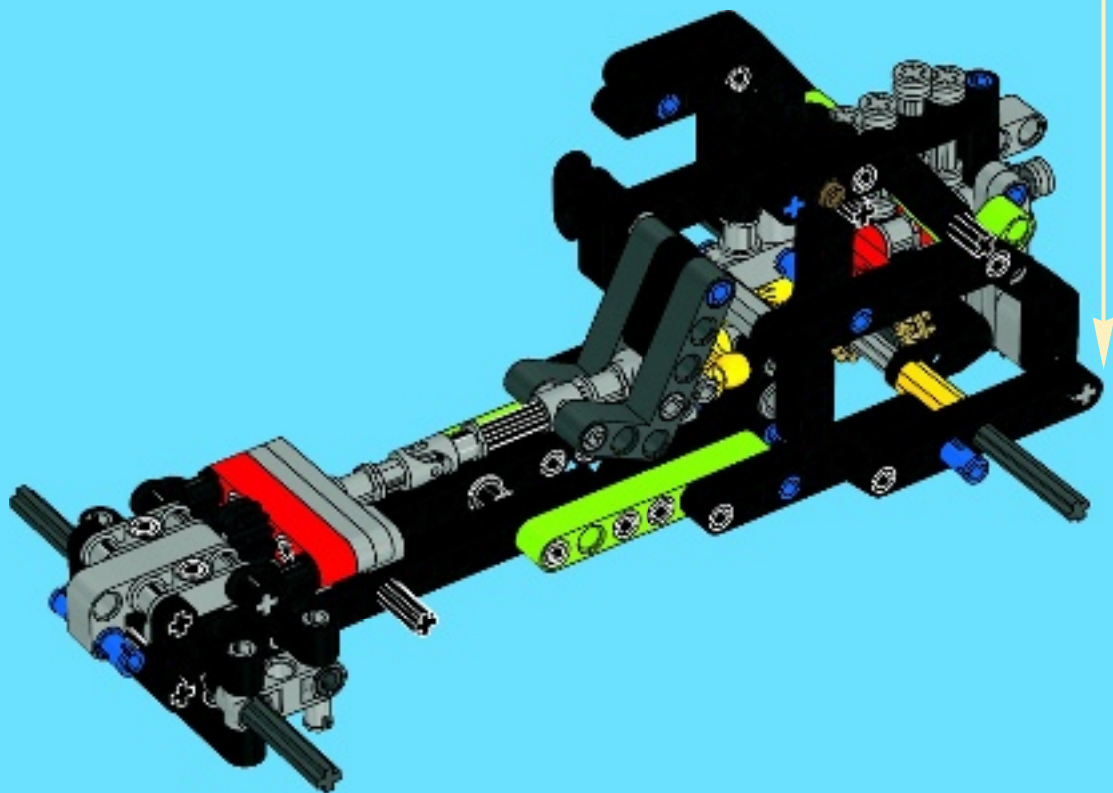

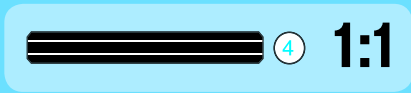
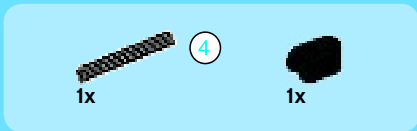

35

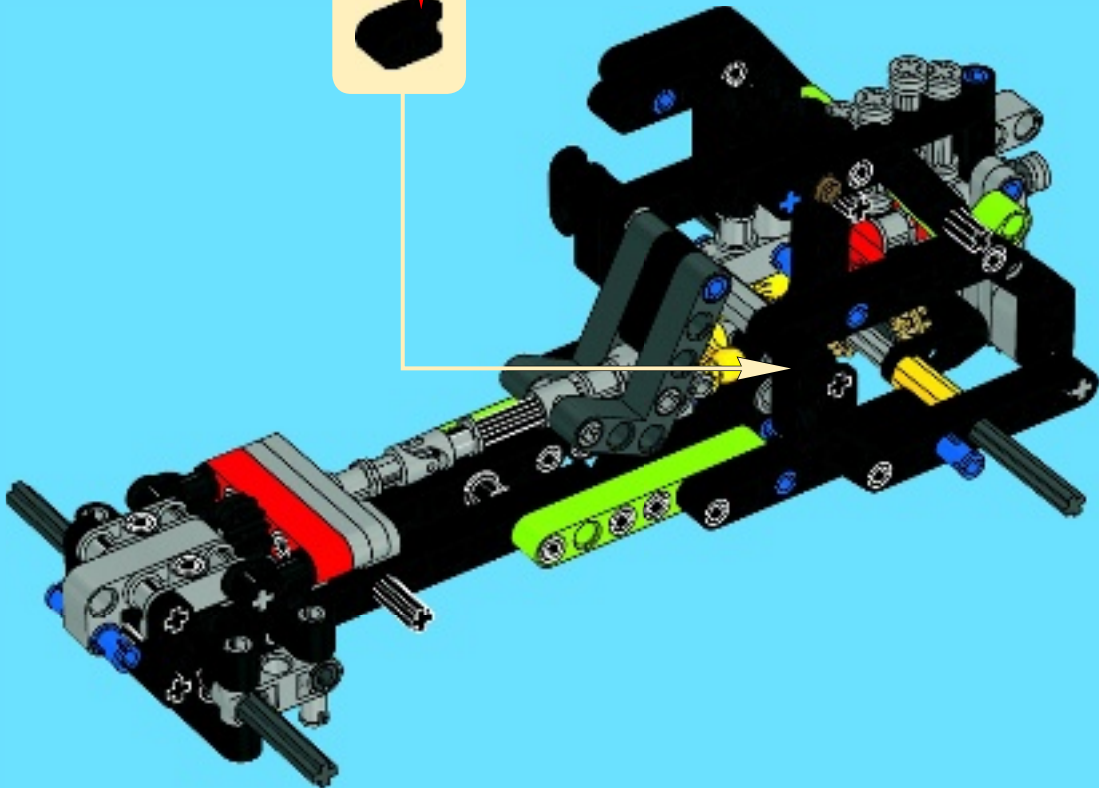
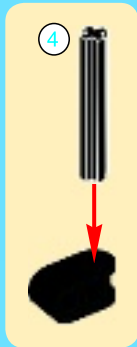



2x

36

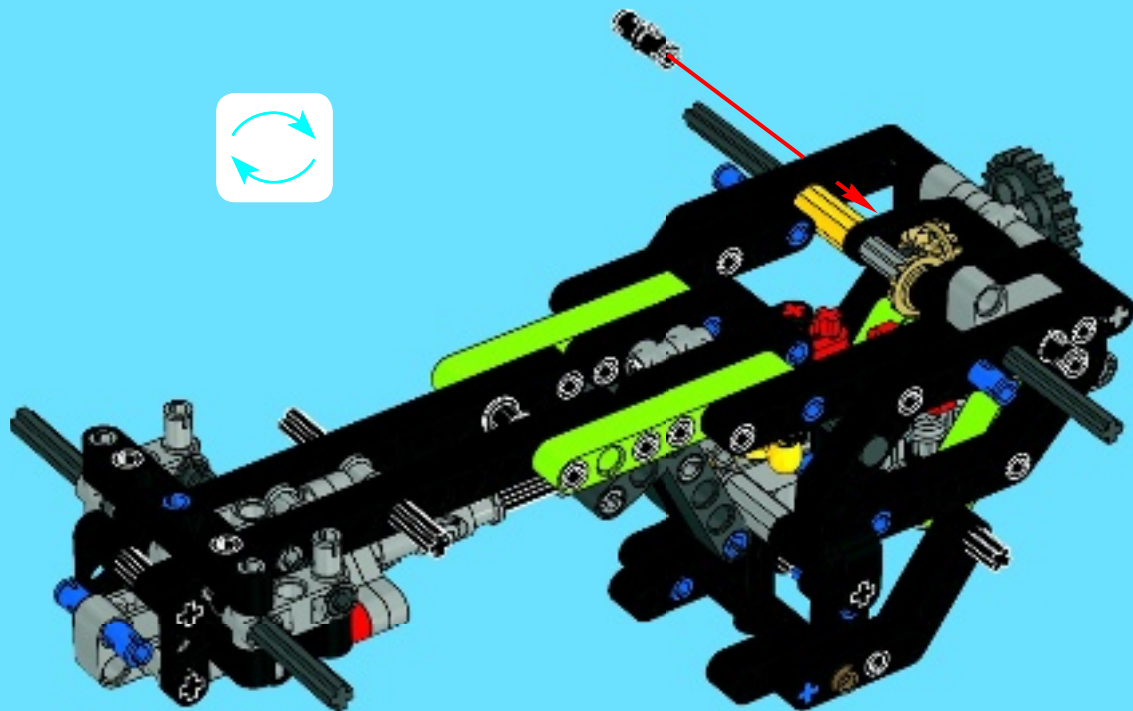



2x

37

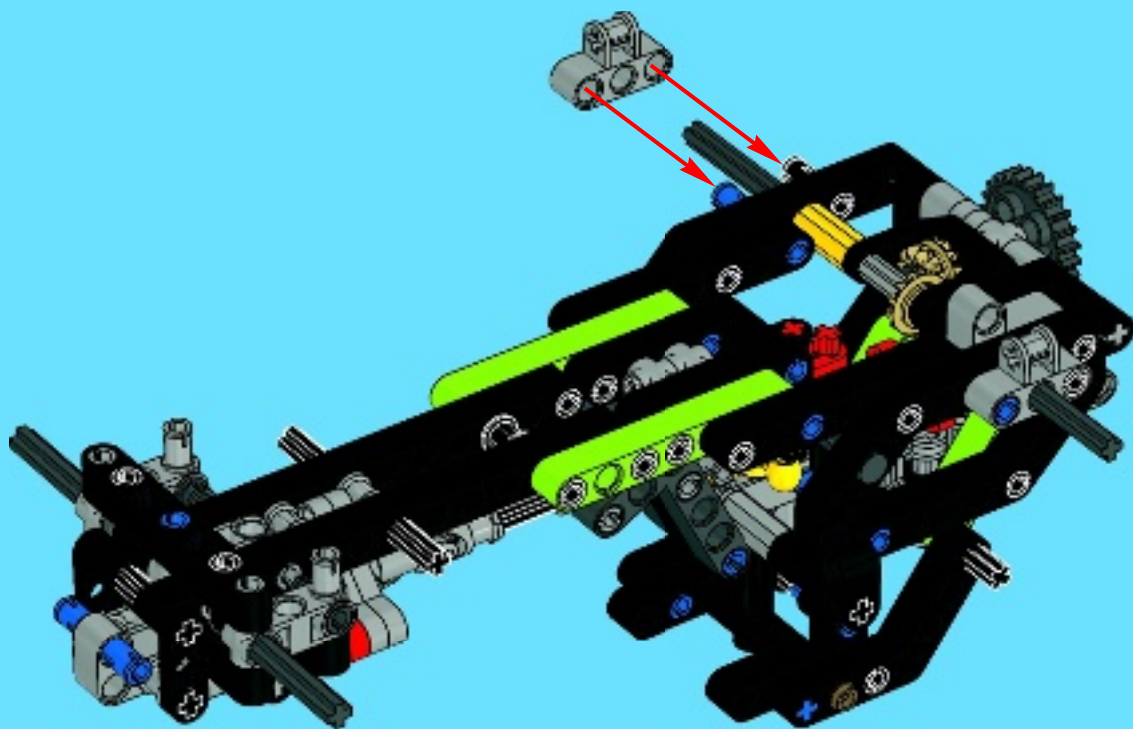

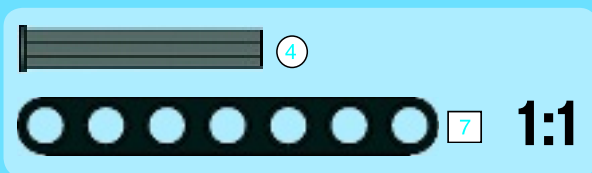
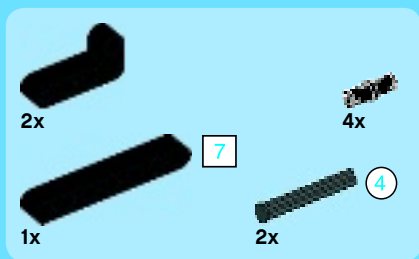

38

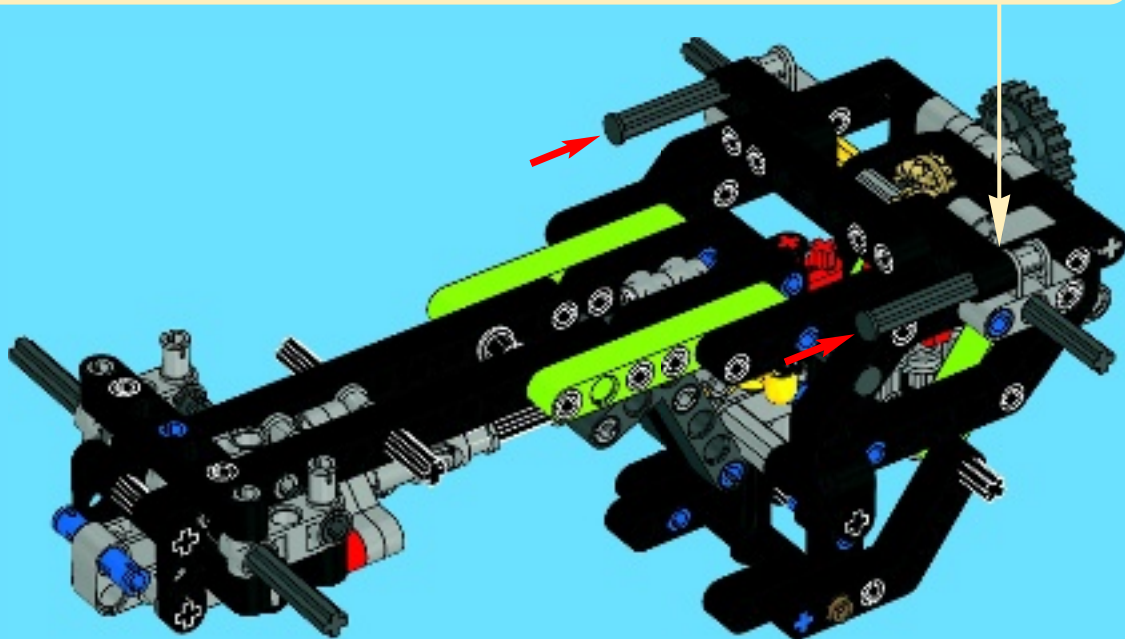
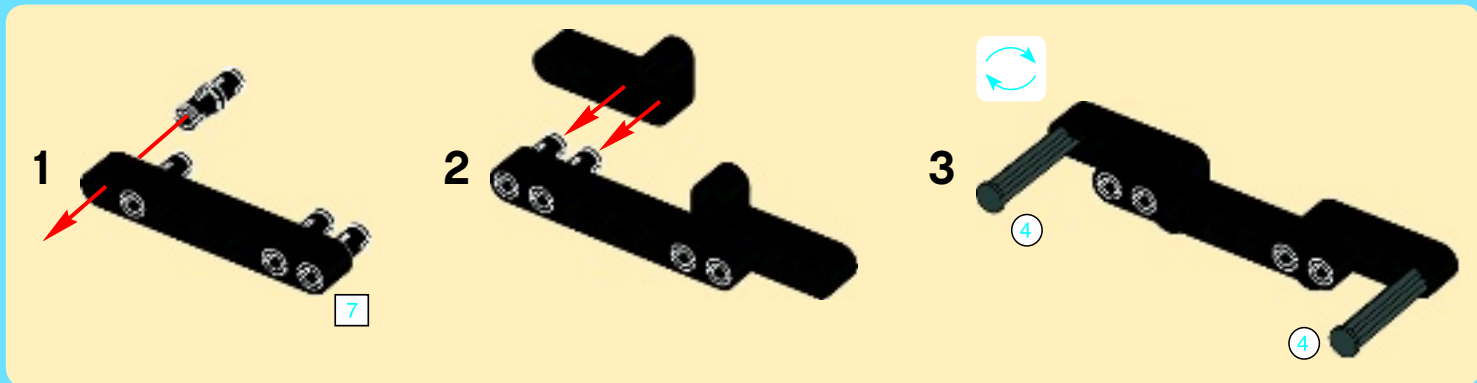



2x



2x

39

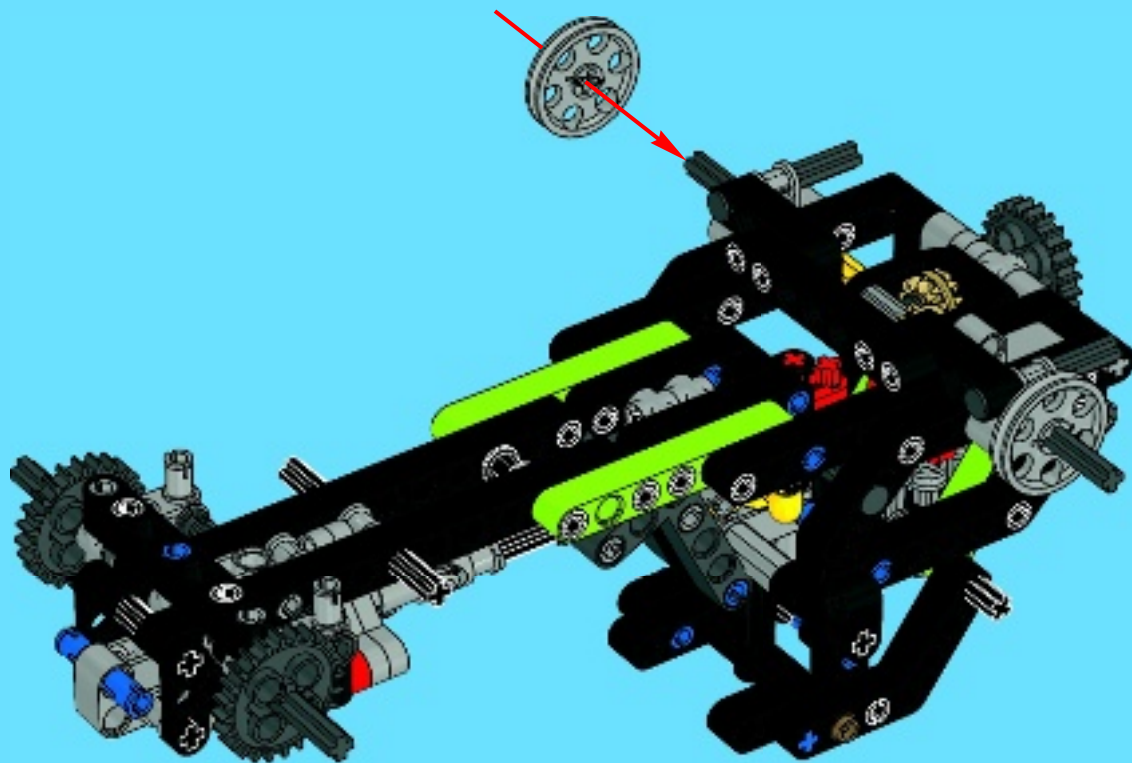



2x



2x

40

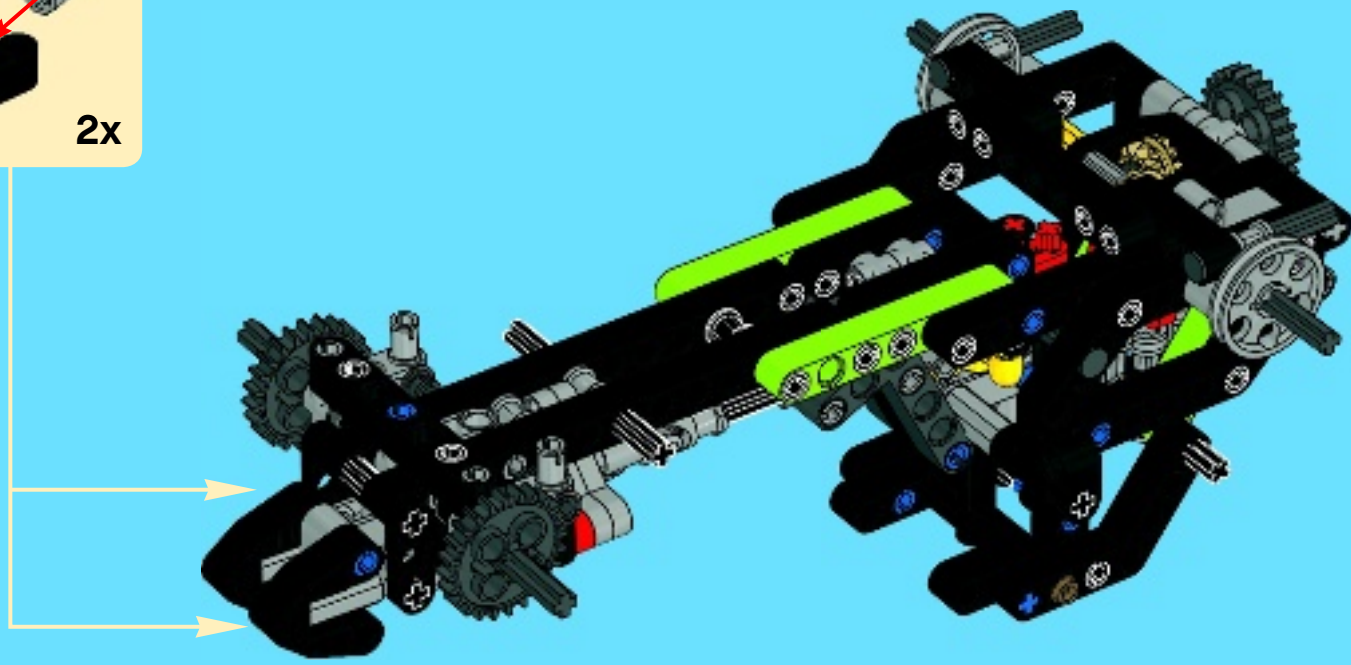
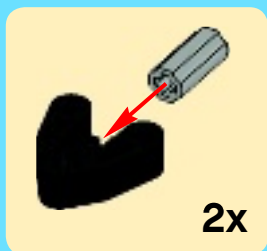

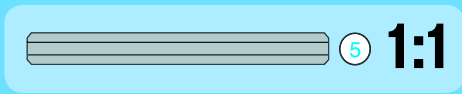
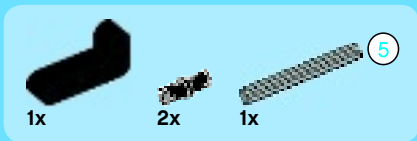

41

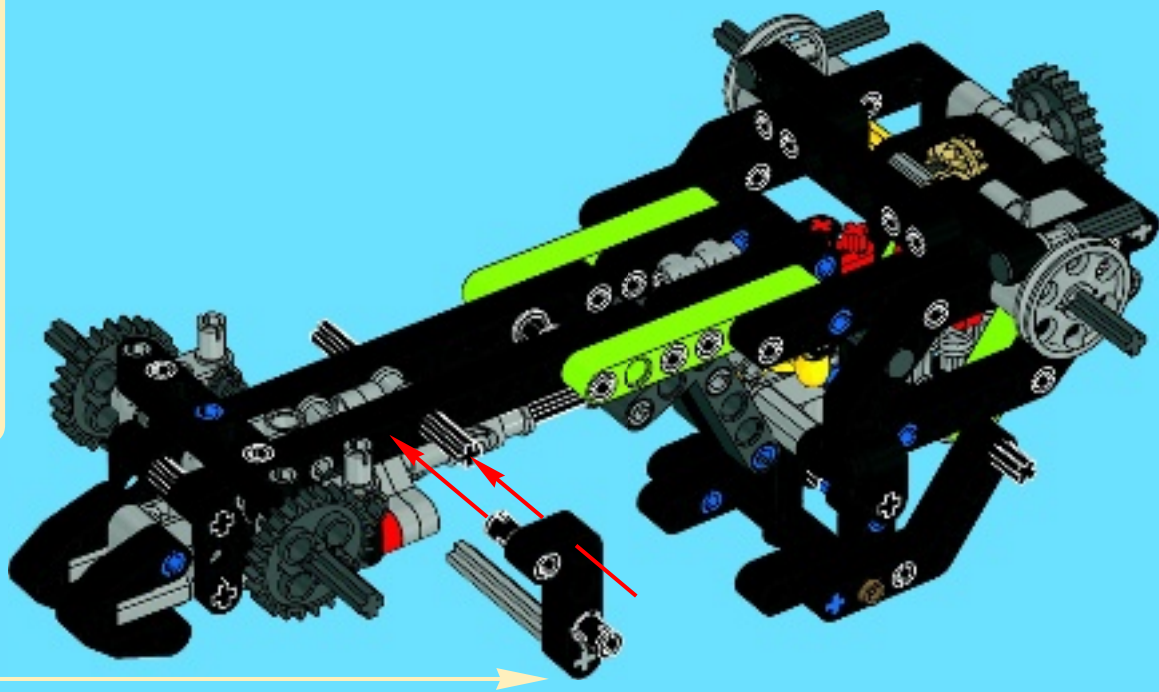
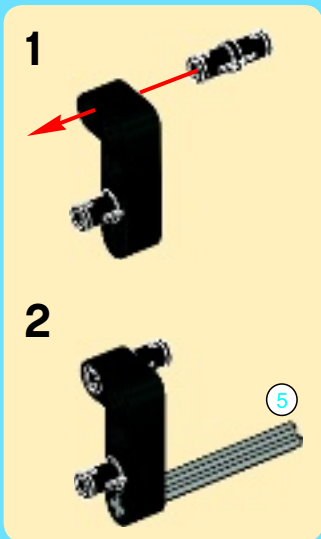



1

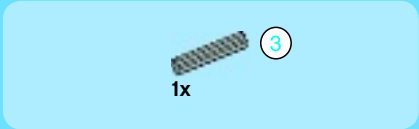
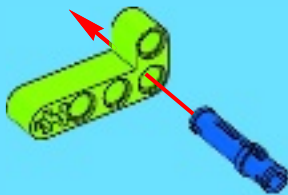

2



3

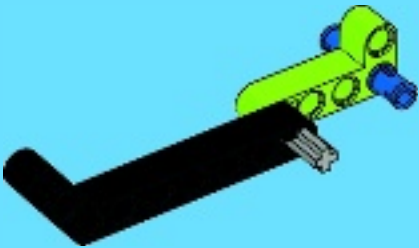

4

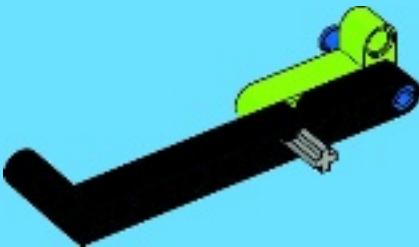



5

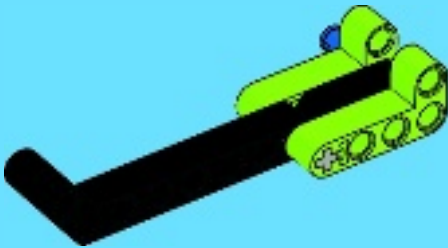

6

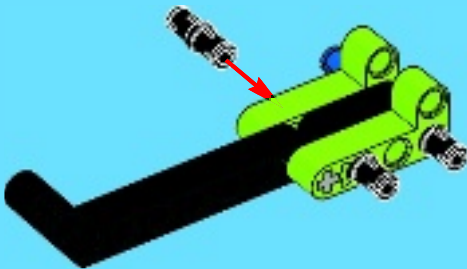

7

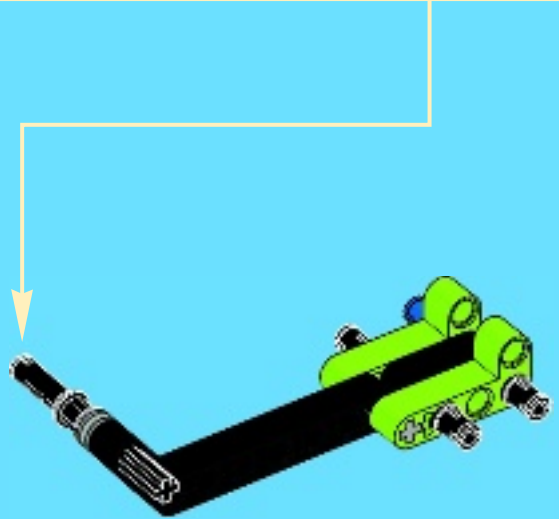

1:1



1x



1x

8

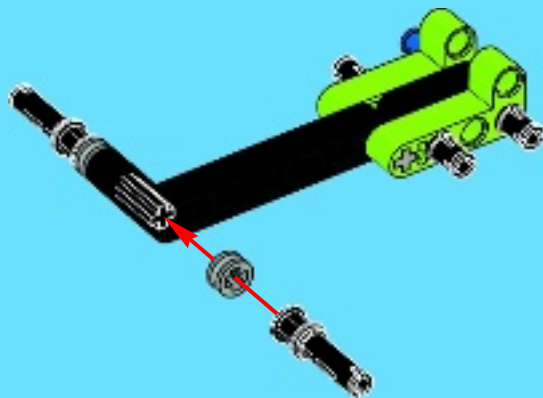

42

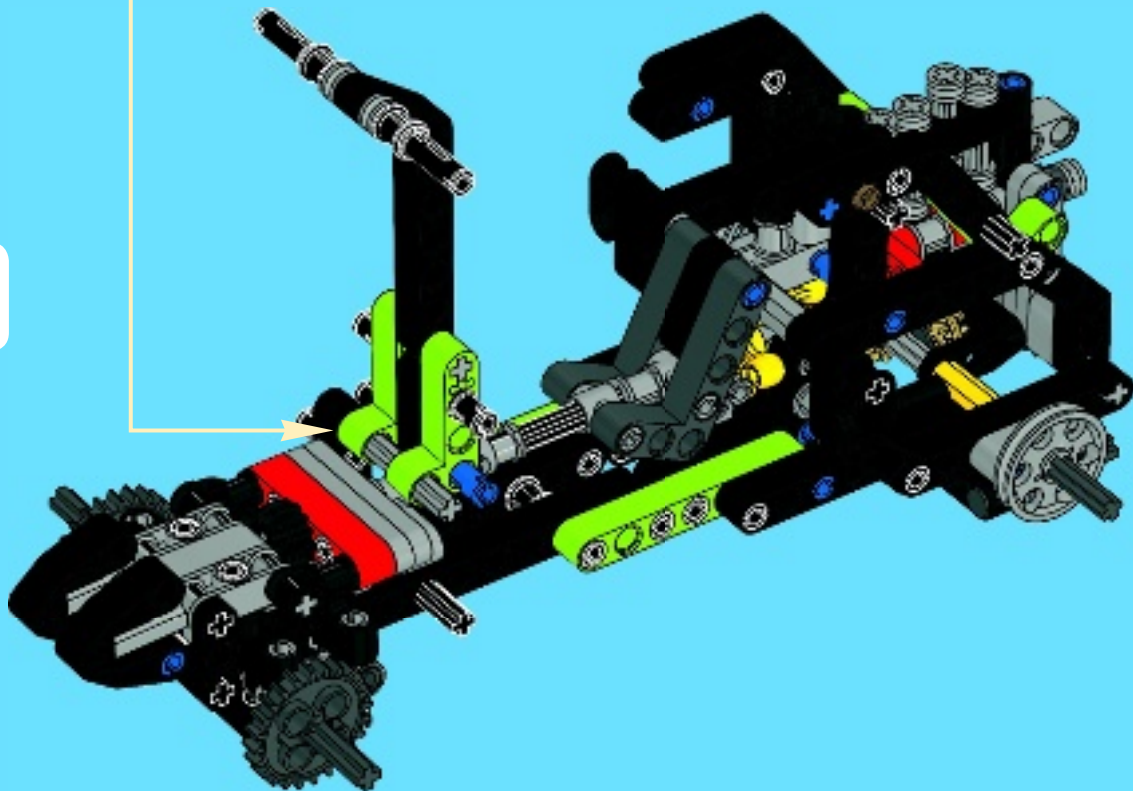



1x



2x

43

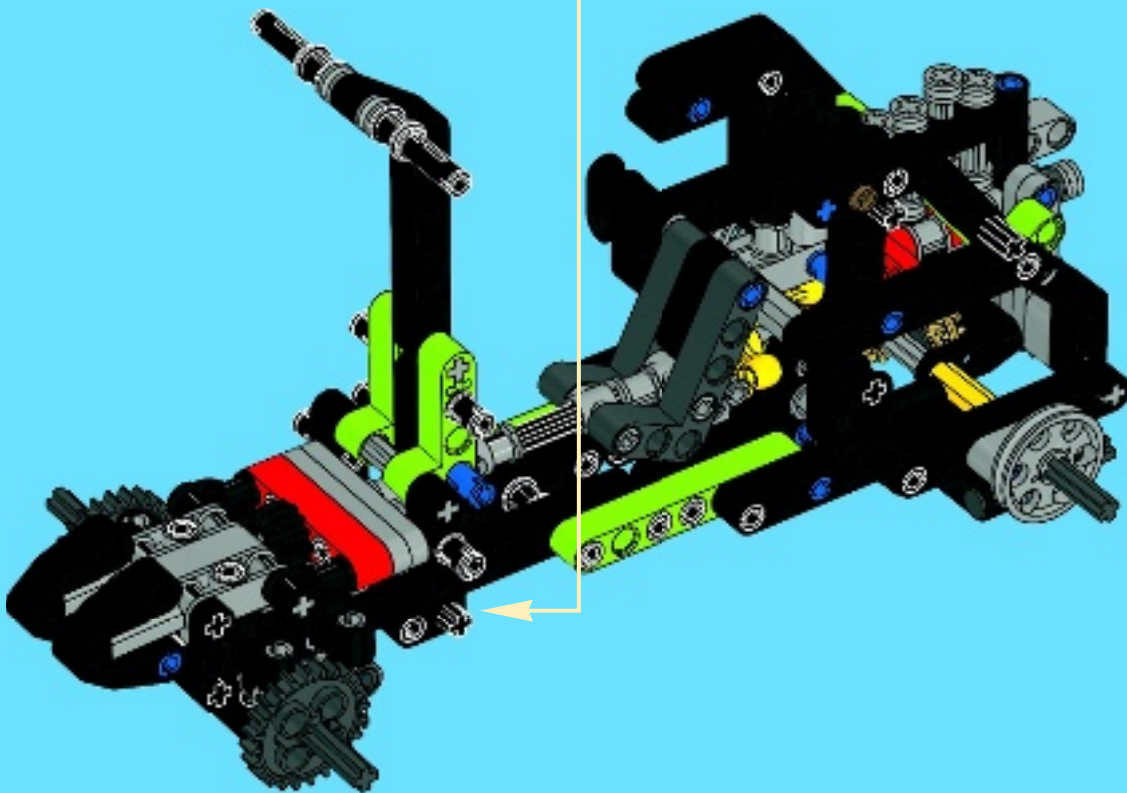
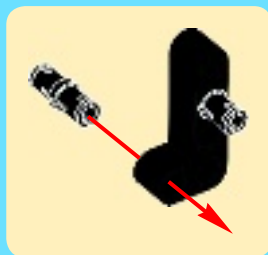

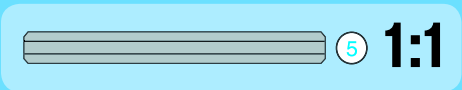
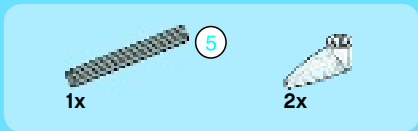

44

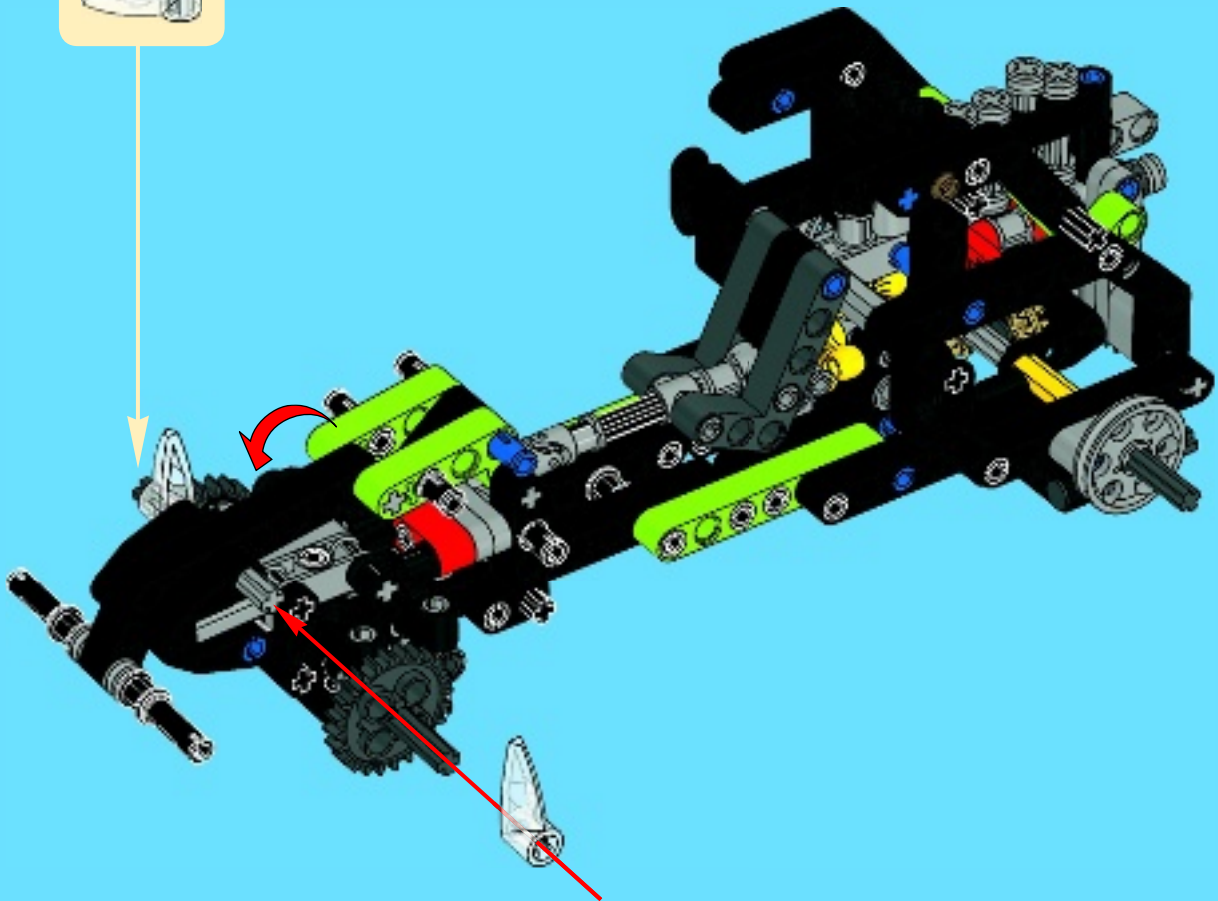
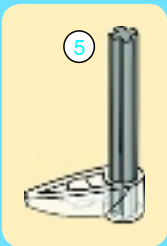



2x



1x



2x

45

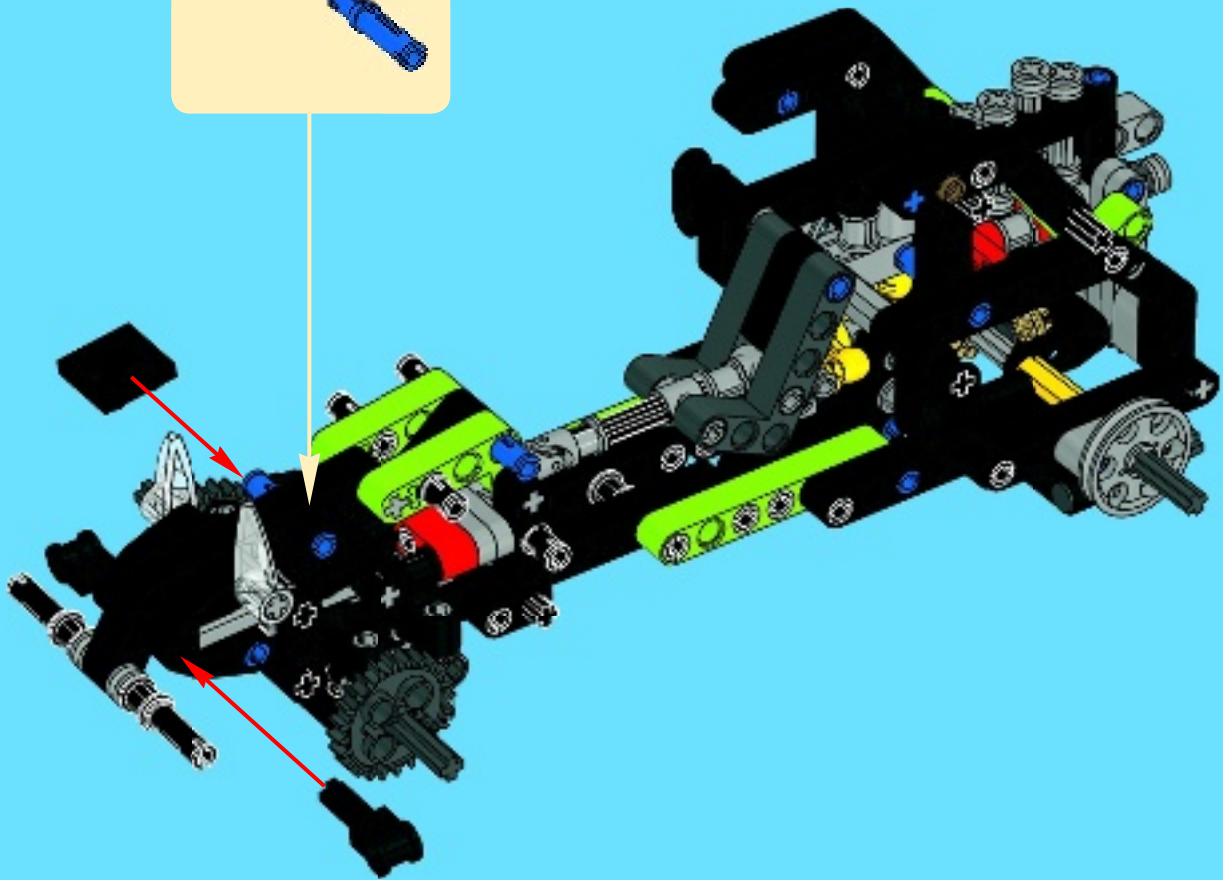
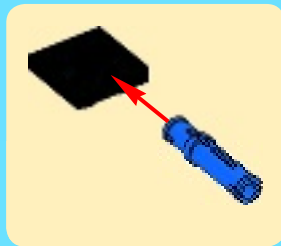

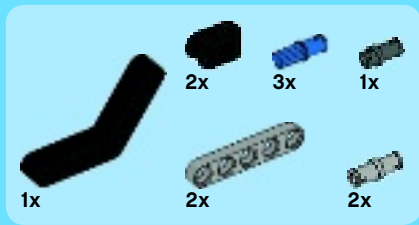

46

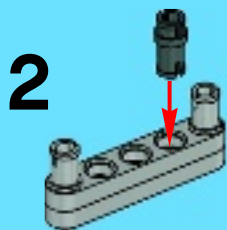
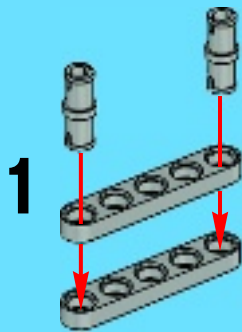

3

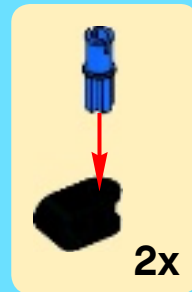
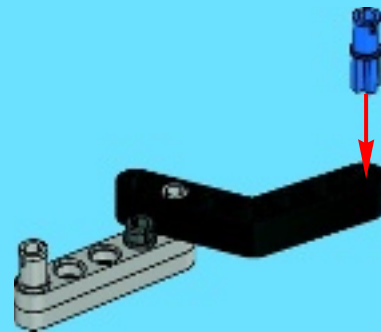

4

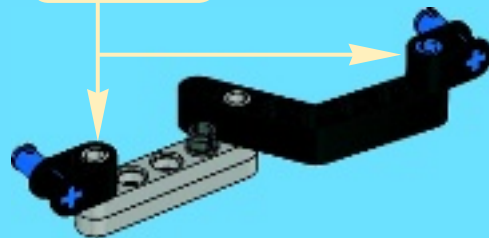

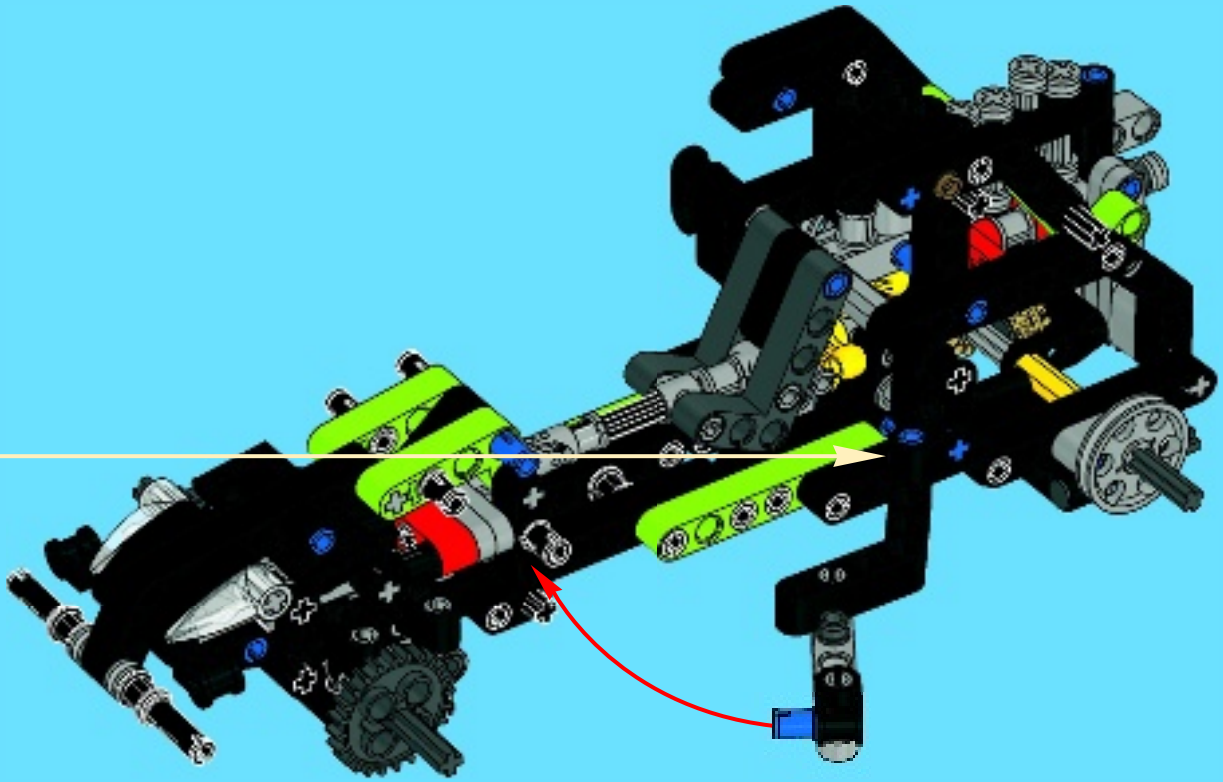

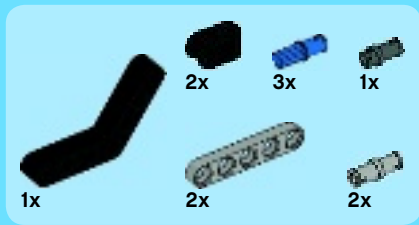

47

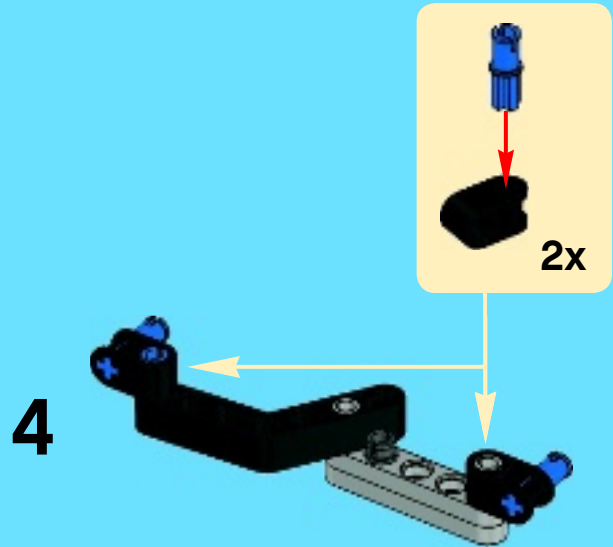
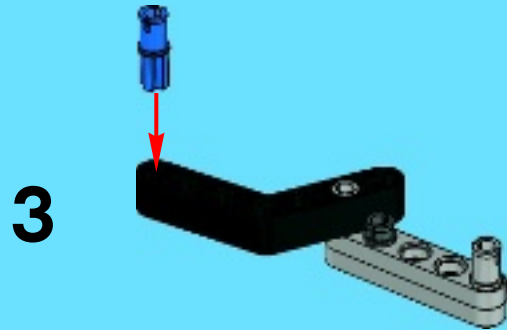
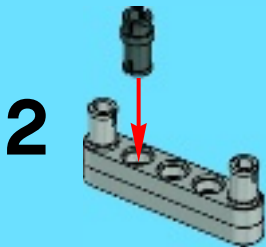
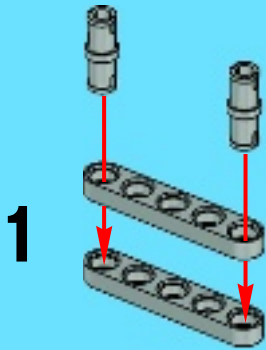

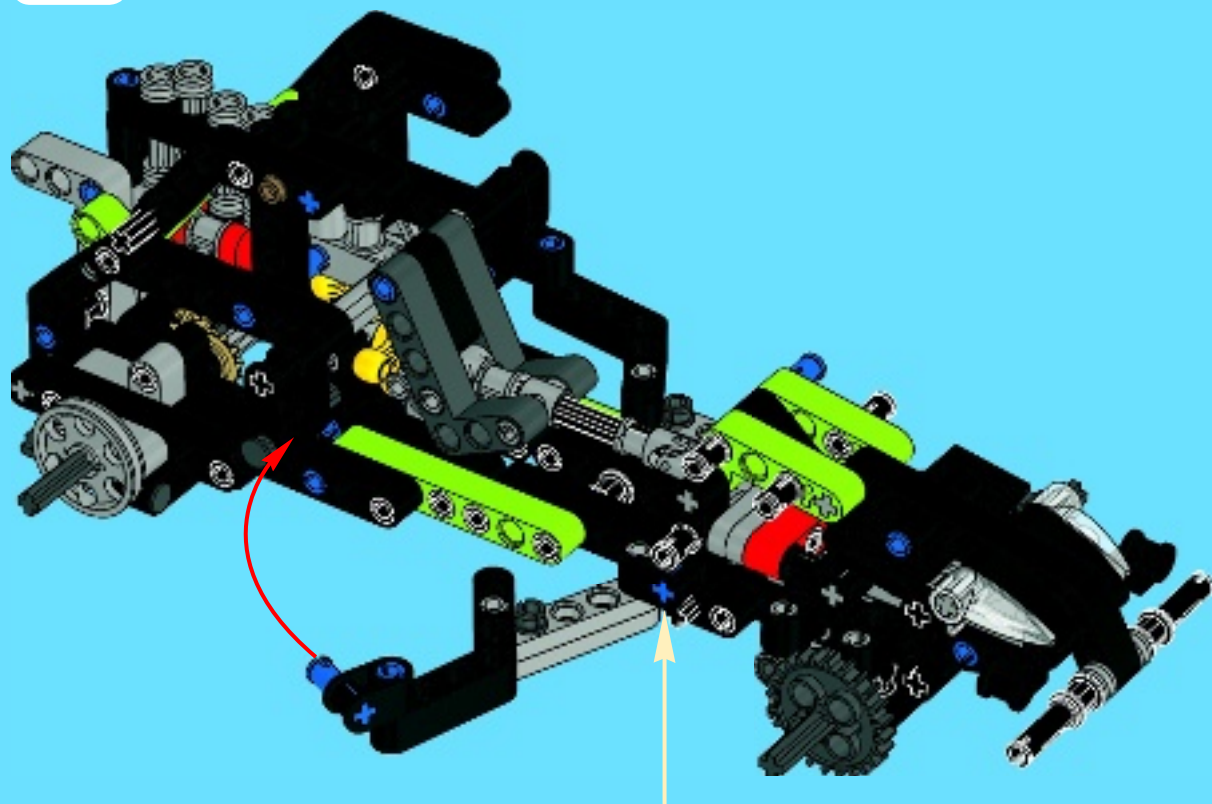

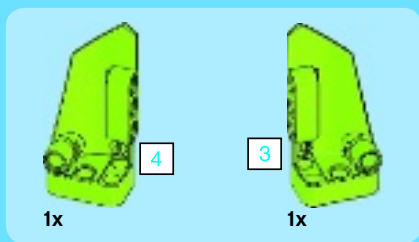

48

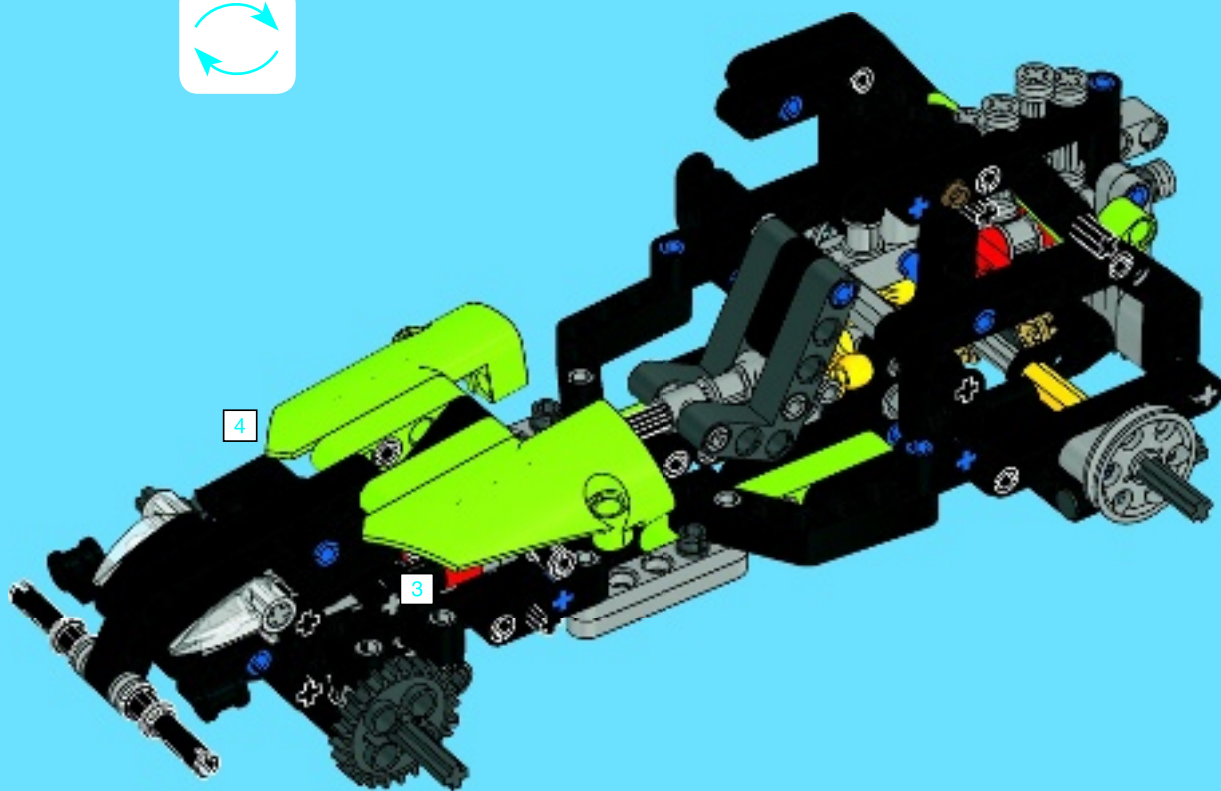



1

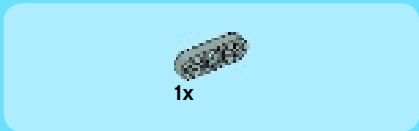
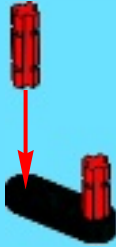

2

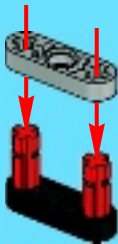

3

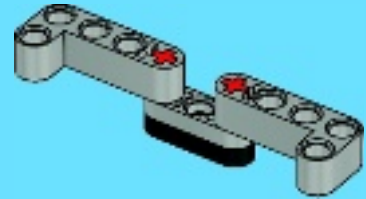

4

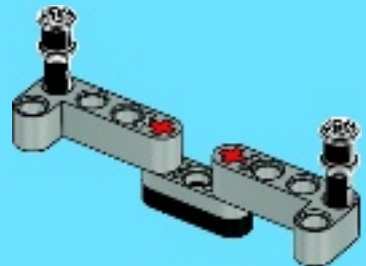



2x

5

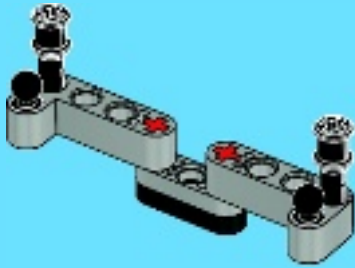

6

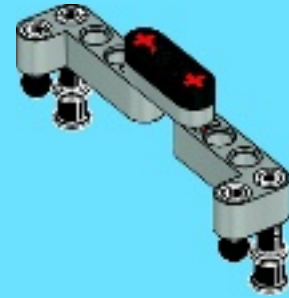

49

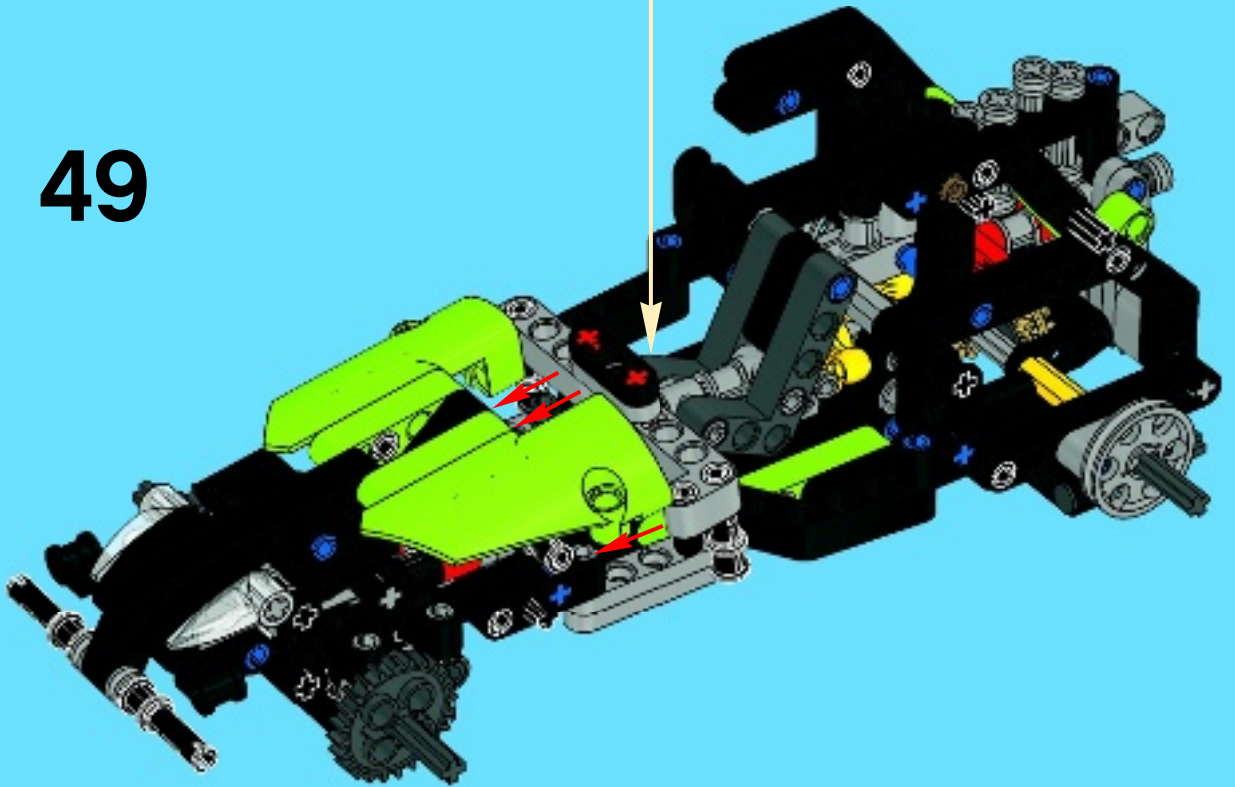

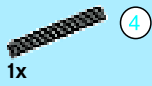

50

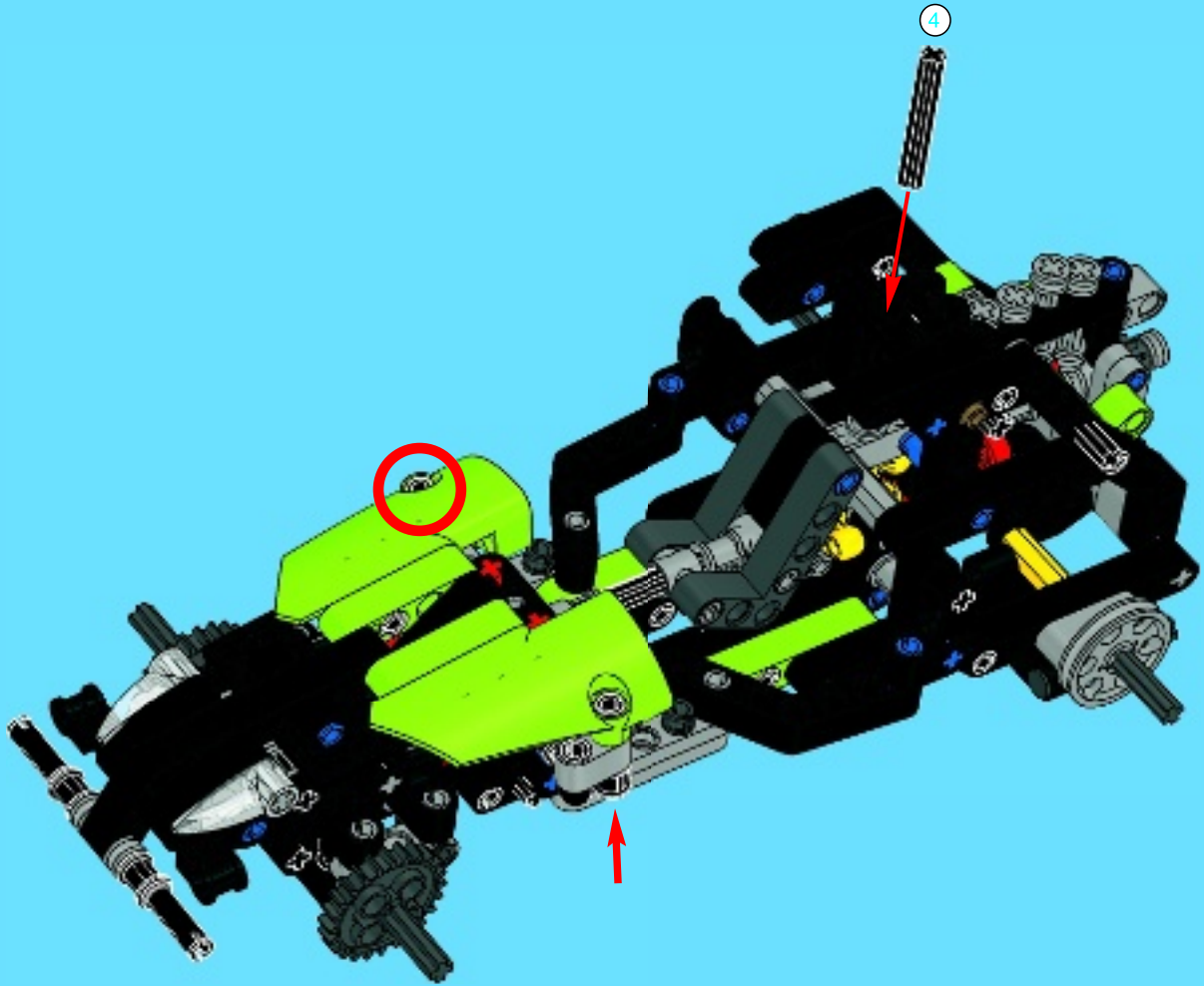



1x



1x

51

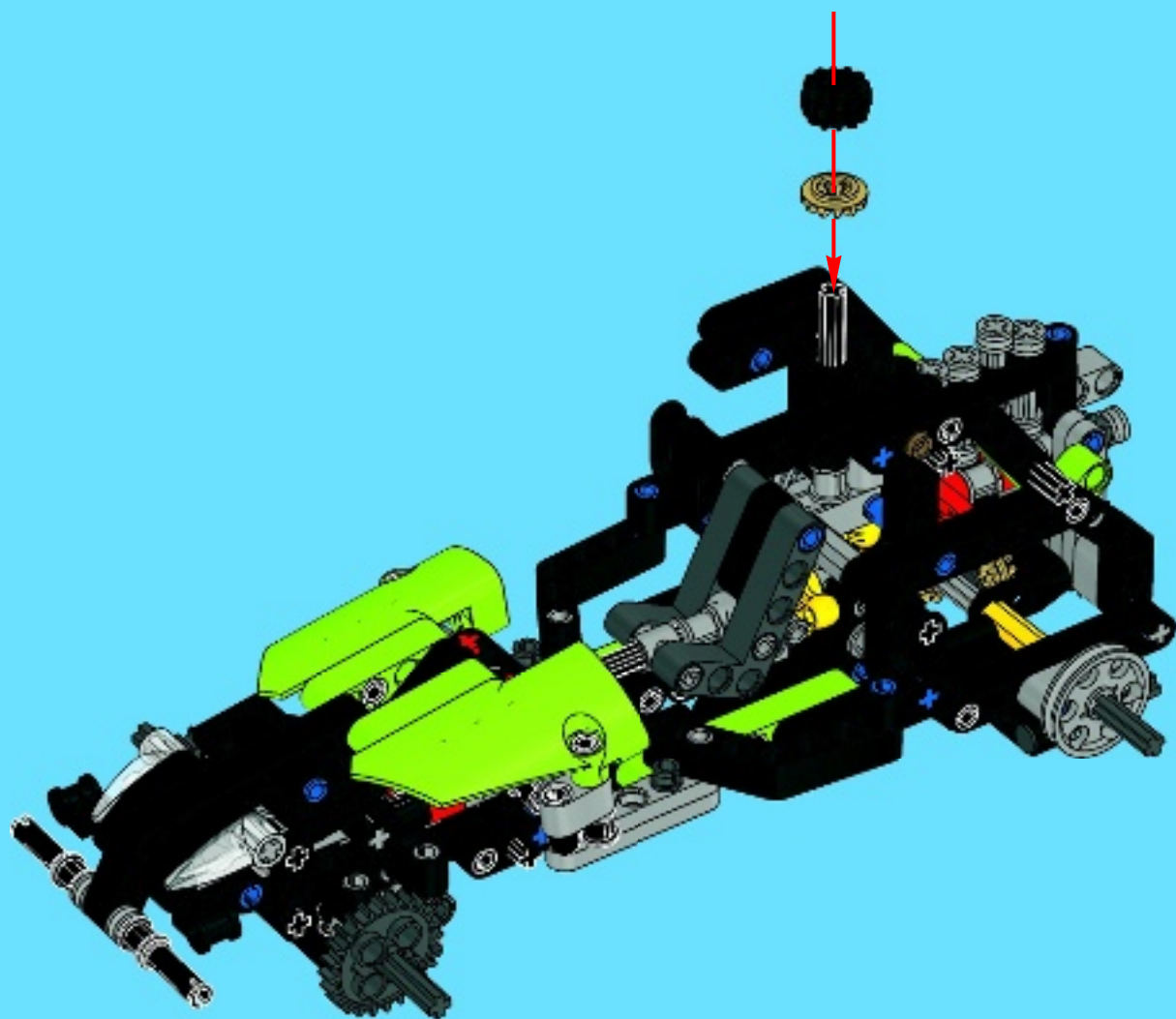

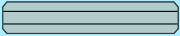

 ③ 1:1

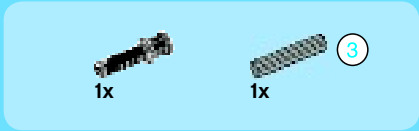

1

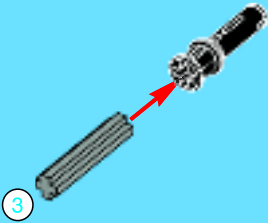

2

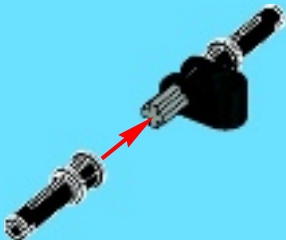

3

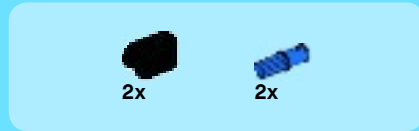

4

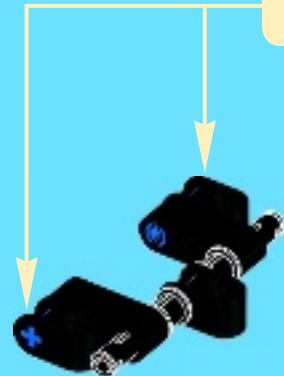
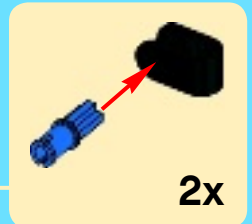

2x

5



1x

1x

6

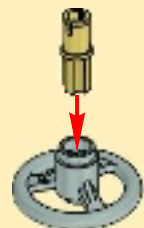

52

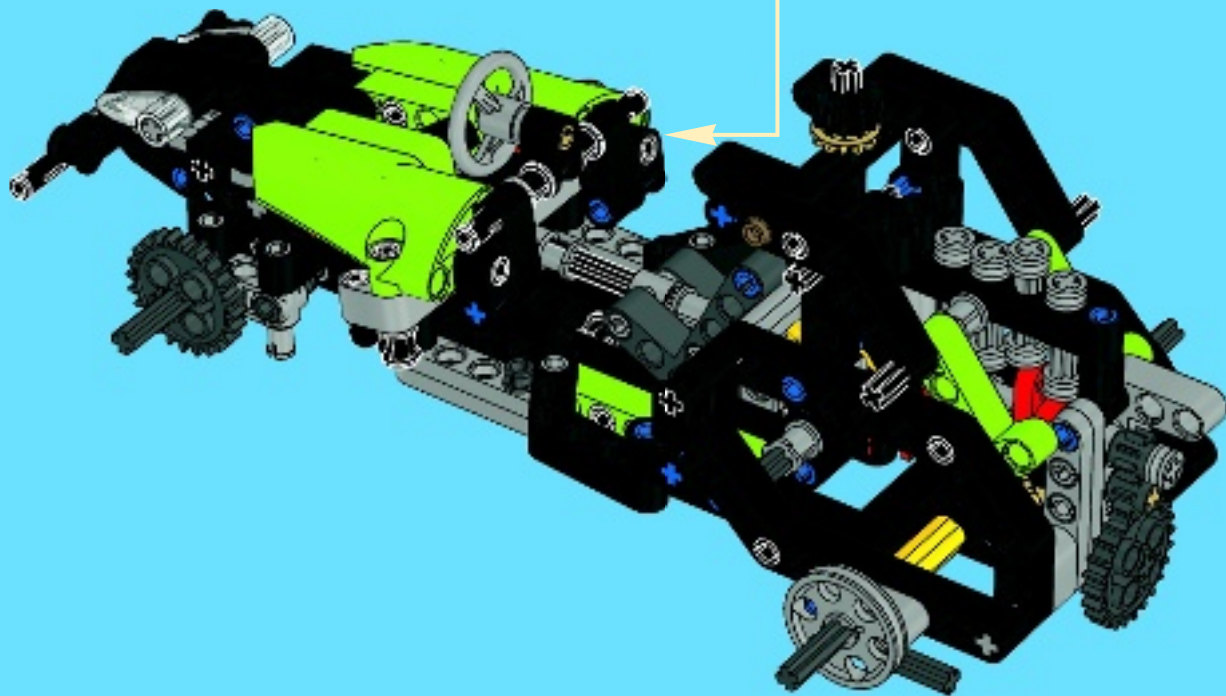

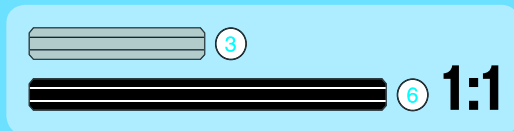
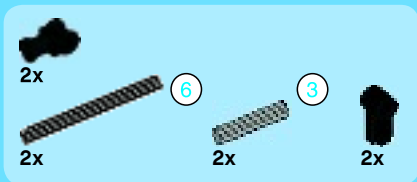

53

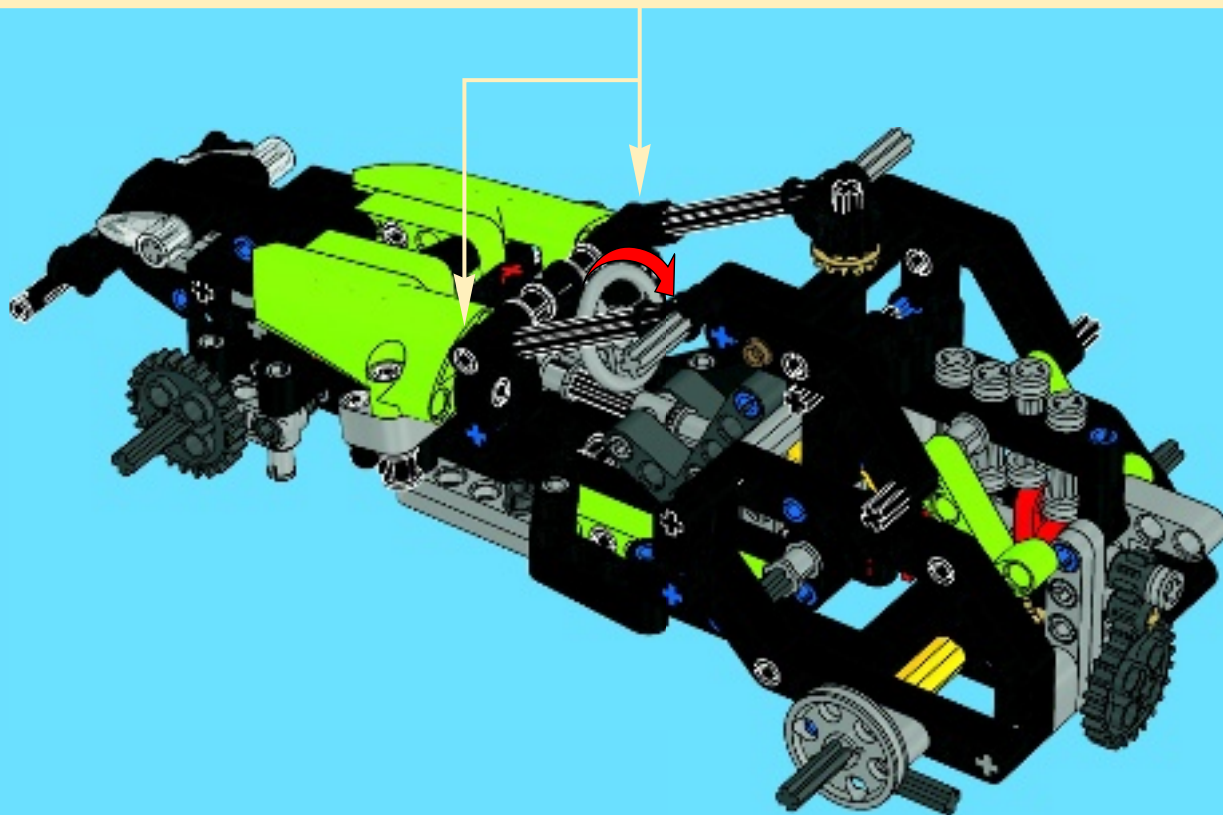
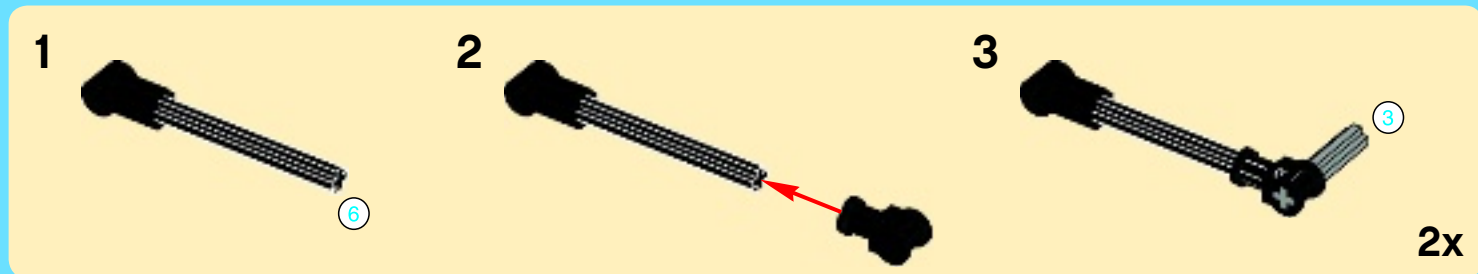



1x

54

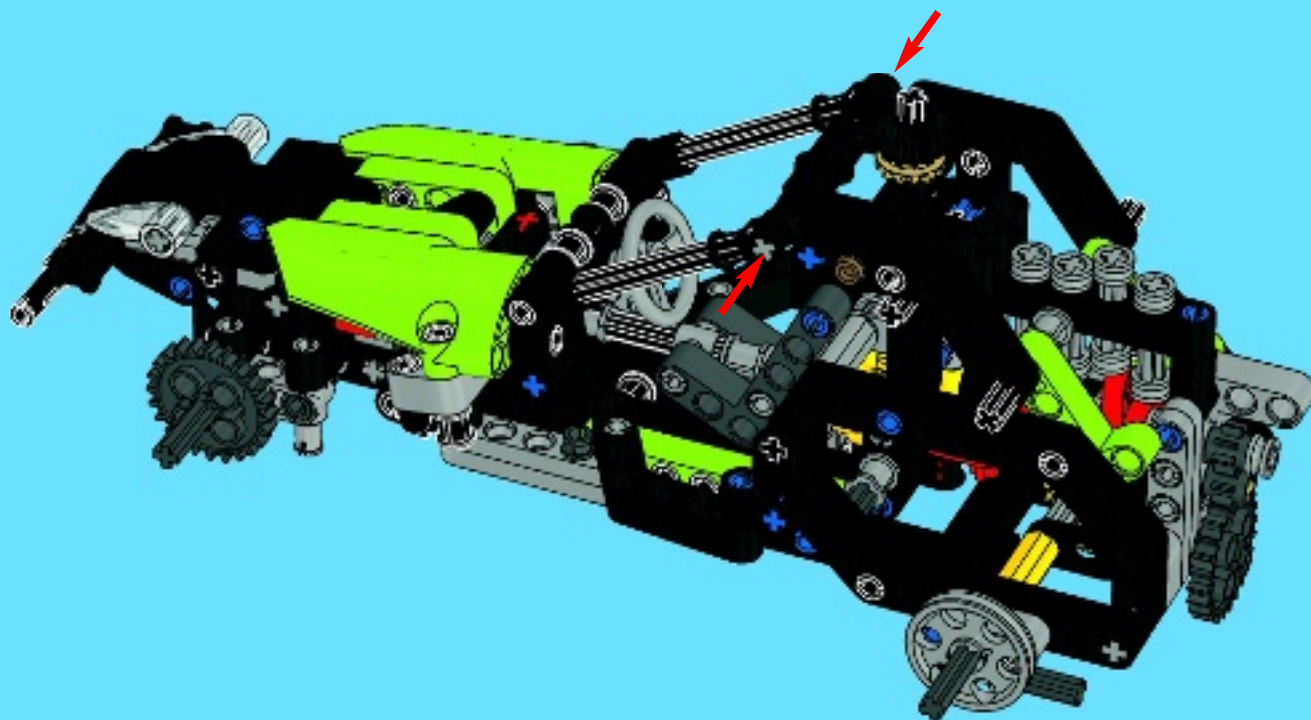

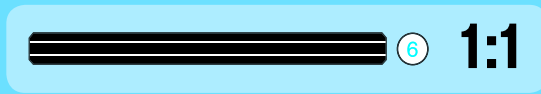
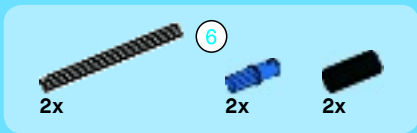

55

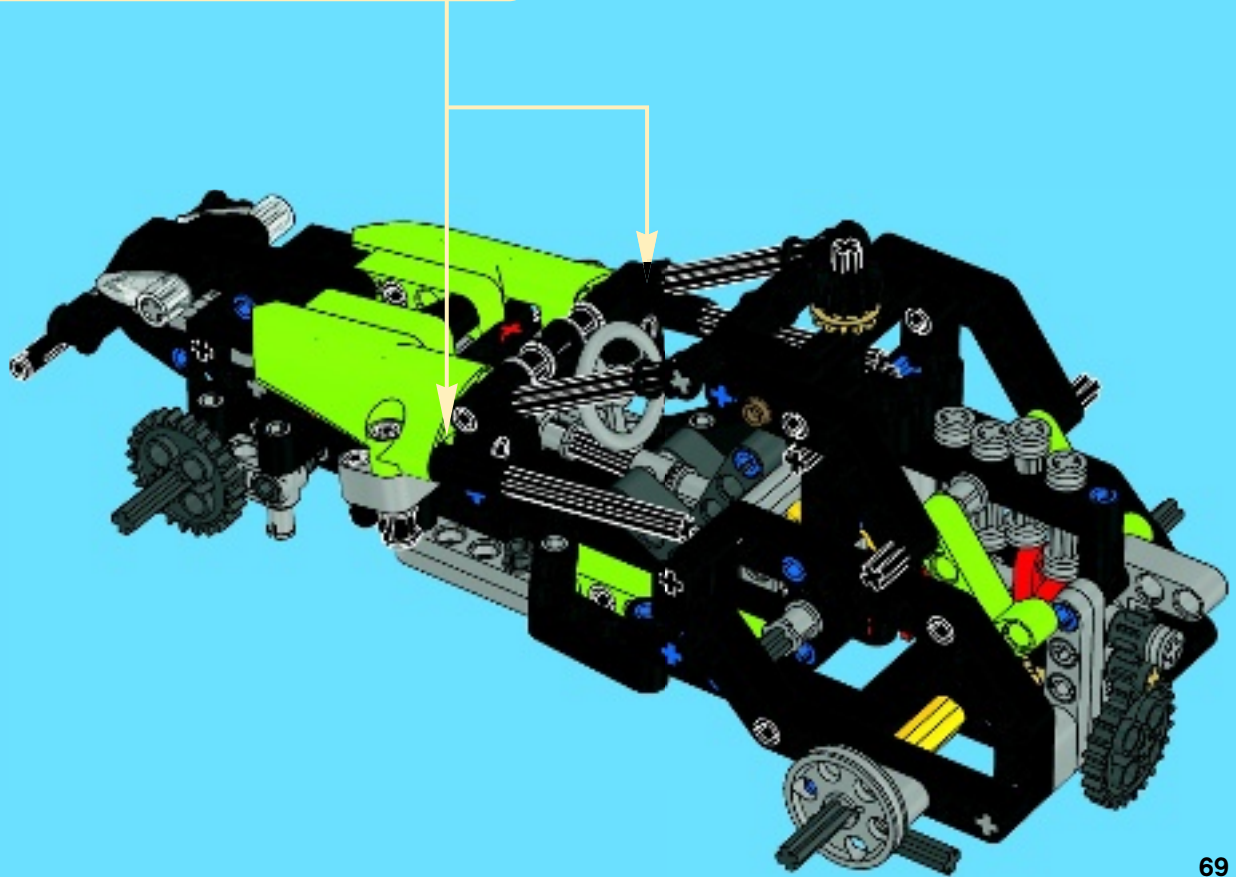
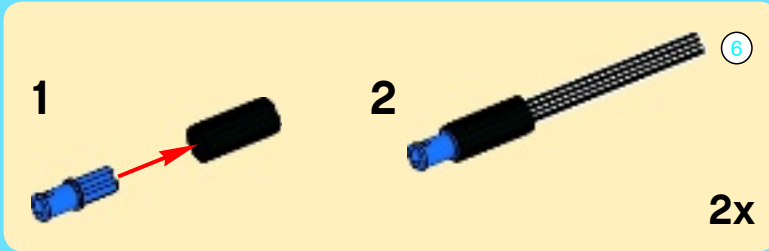



2x



2x



2x

56

1

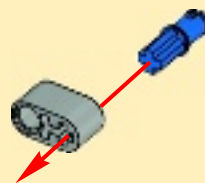

2



2x

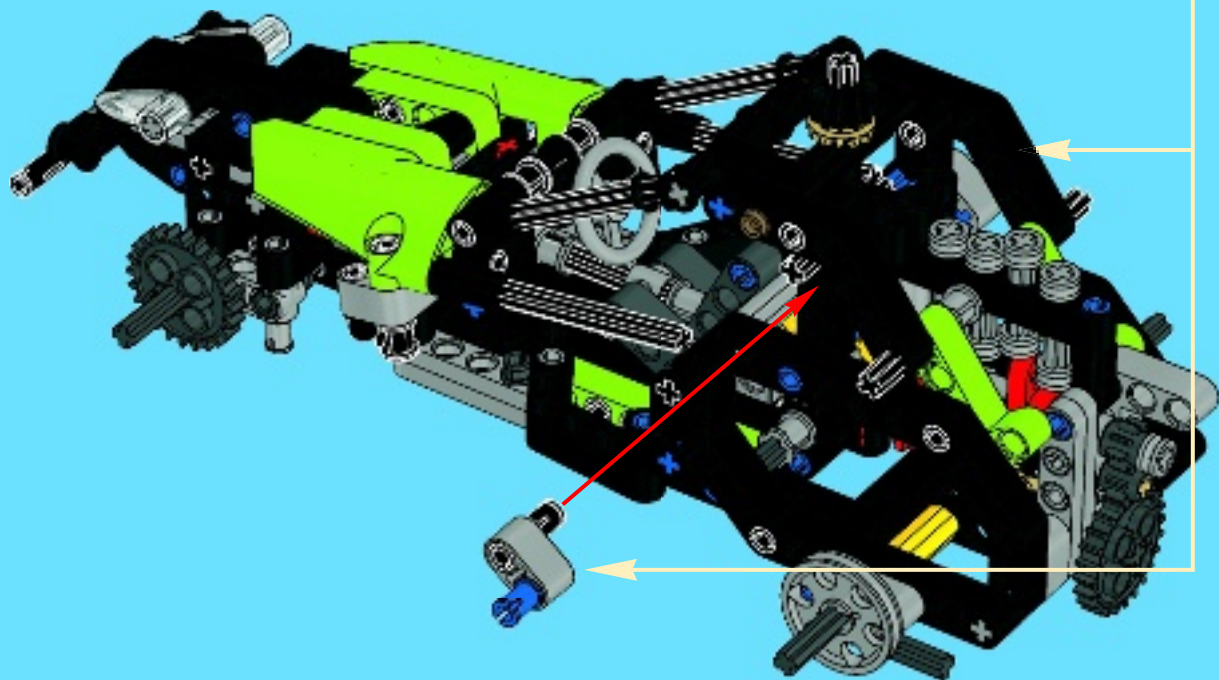

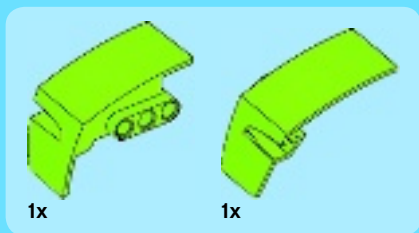

57

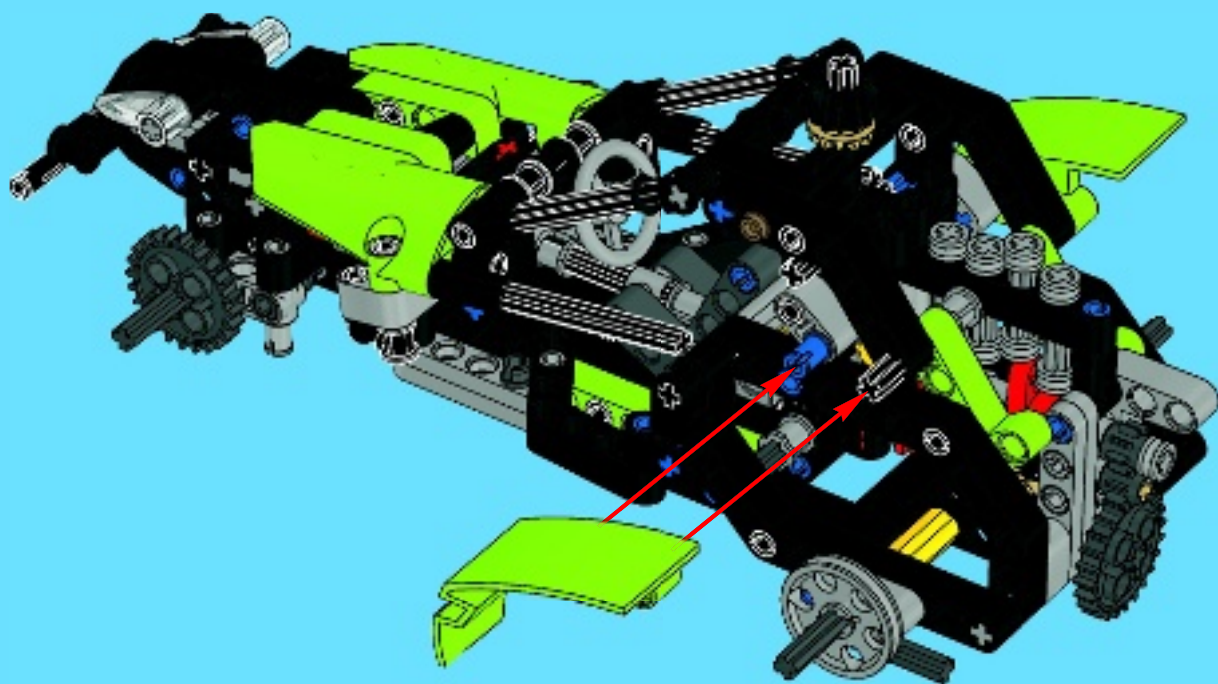

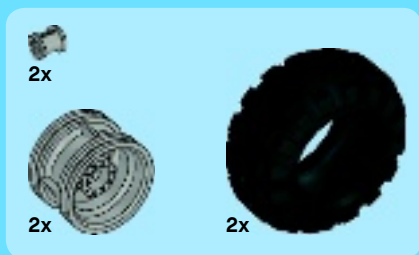

58

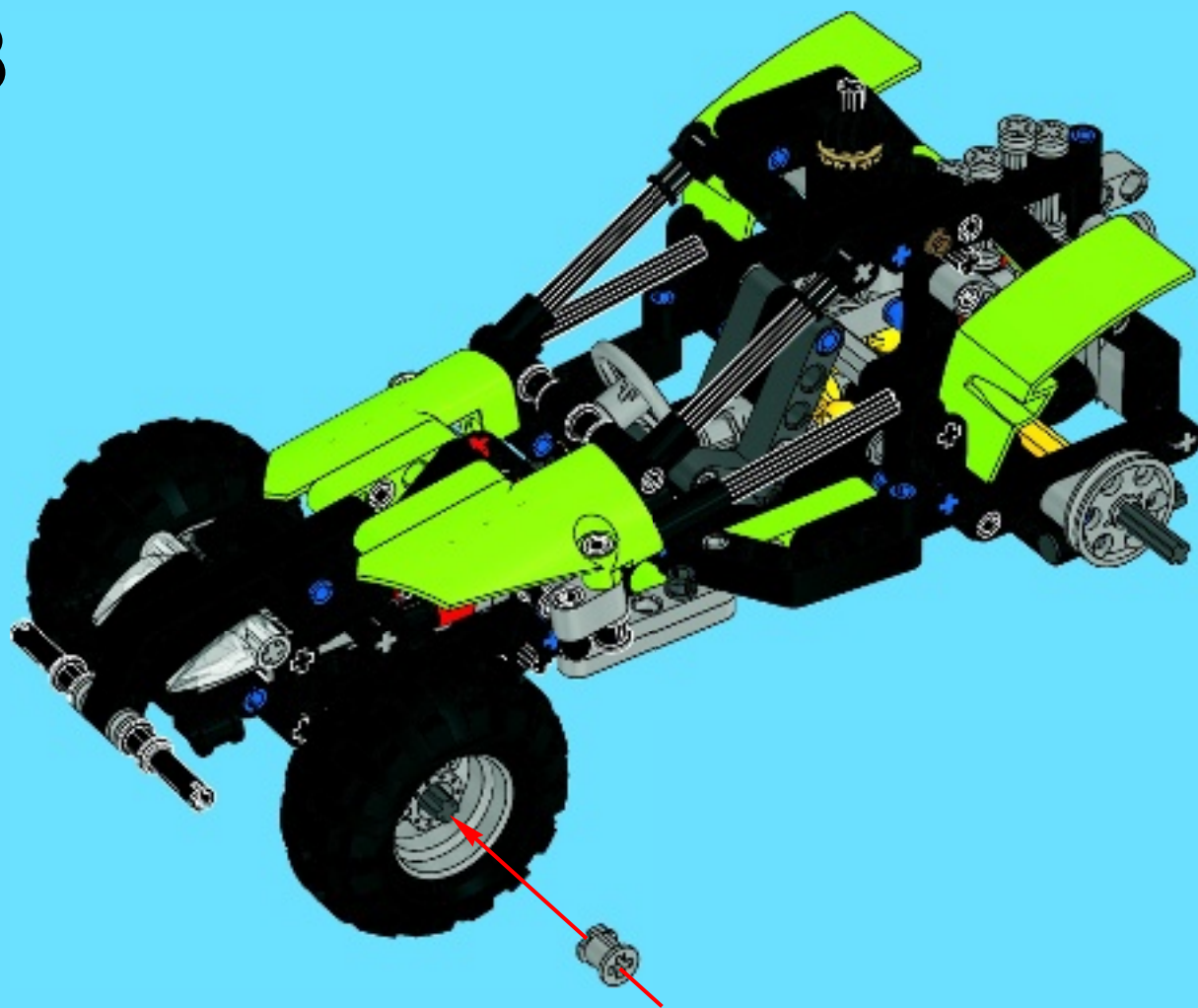



59

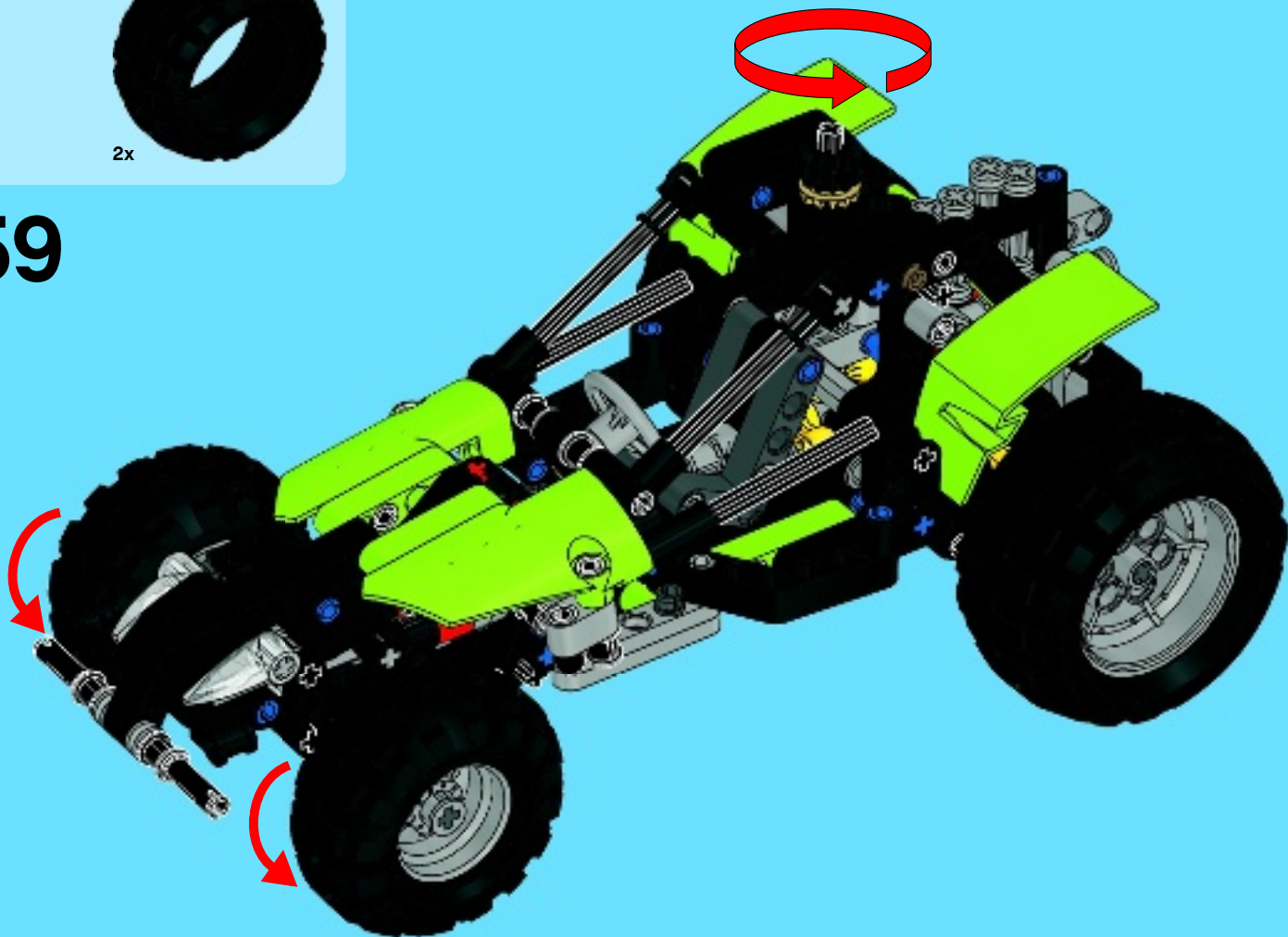

1



2



3



www.LEGOclub.com/Max



club™

FREE*! GRATIS! GRATUIT!

*Paid subscription in Australia and New Zealand.
*Abonnement payant en Australie et Nouvelle-Zélande.

©2012 The LEGO Group.

Technic.LEGO.com



Mercedes-Benz and the design of the enclosed product are subject to intellectual property protection owned by Daimler AG. They are used by LEGO System A/S under license.
Mercedes-Benz et le design du produit inclus sont sujets à la protection de la propriété intellectuelle dont Daimler AG en est le propriétaire. Ils sont utilisés par LEGO System A/S sous licence.
Mercedes-Benz y el diseño del producto incluido están sujetos a la protección de la propiedad intelectual de Daimler AG. Son utilizados por LEGO System A/S bajo licencia.



WIN!

Go to www.LEGOsurvey.com/product to fill out a survey for a chance to win a cool LEGO® Product.
No purchase necessary.
Open to all residents where not prohibited.

 www.LEGO.com



www.LEGOsurvey.com/product

GEWINNE! WIN!

Nimm an der Umfrage auf www.LEGOsurvey.com/product teil und hab die Chance ein cooles LEGO® Produkt zu gewinnen!
Die Teilnahme am Gewinnspiel führt zu keinerlei Kaufverpflichtungen. Teilnahme in allen nicht ausgeschlossenen Ländern möglich.

Ga naar www.LEGOsurvey.com/product, vul een enquêteformulier in en maak kans op een cool LEGO® product.
Geen aankoopverplichting, iedereen mag deelnemen, uitzonderend ingezetenden van landen waar een enquêteverbod geldt.

GAGNE! 当てよう!

Visite www.LEGOsurvey.com/product pour répondre à un questionnaire et avoir une chance de gagner un produit LEGO® très cool!
Aucune obligation d'achat.
Ouvert à tous les résidents des pays autorisés.

www.LEGOsurvey.com/product にアクセスして、アンケートにご記入ください。当選者にはレゴ®製品を差し上げます。
お買い上げの必要はありません。
禁止されていない限り、すべての皆様にご利用いただけます。