



STAR WARSM



8087



1

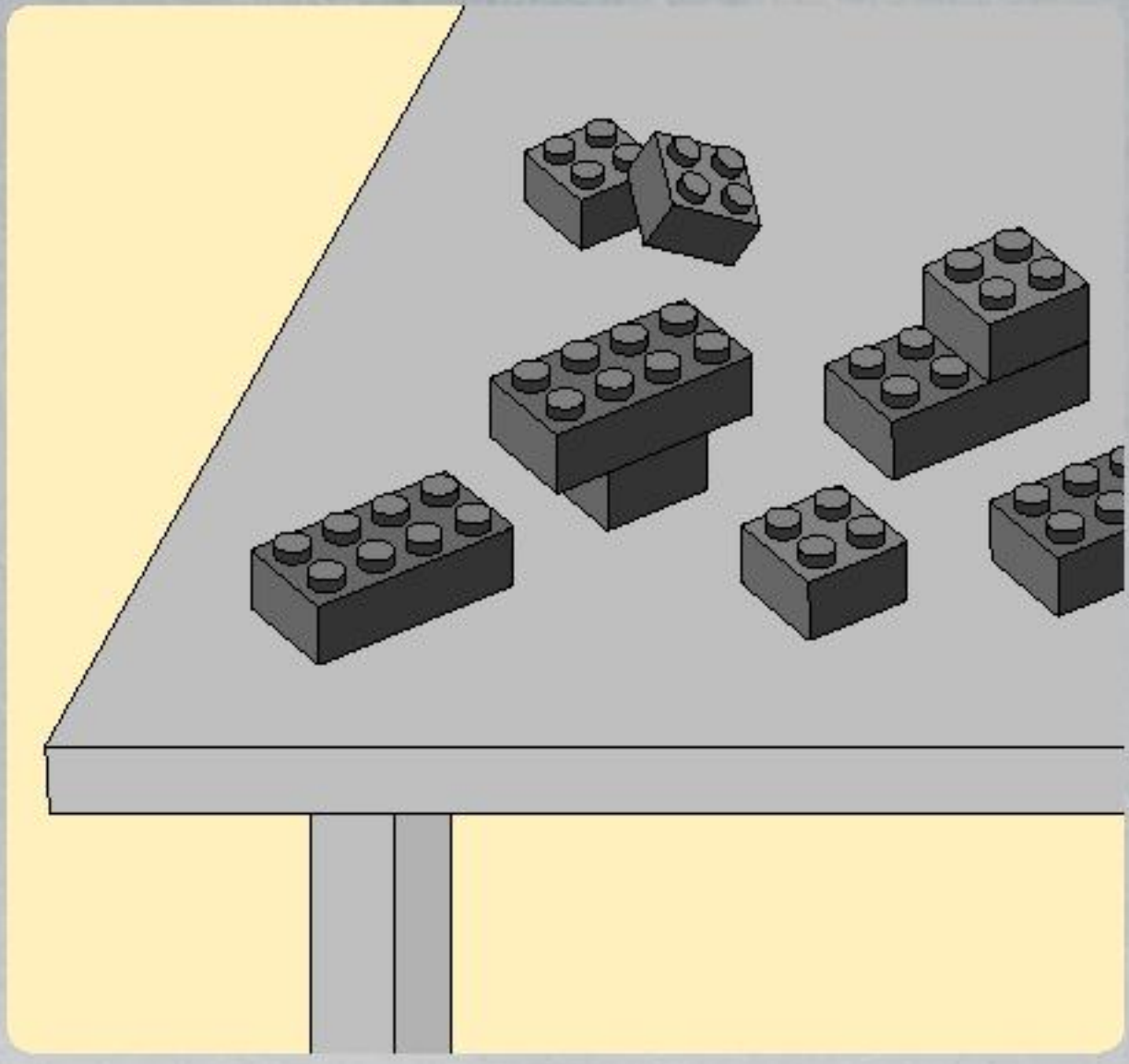
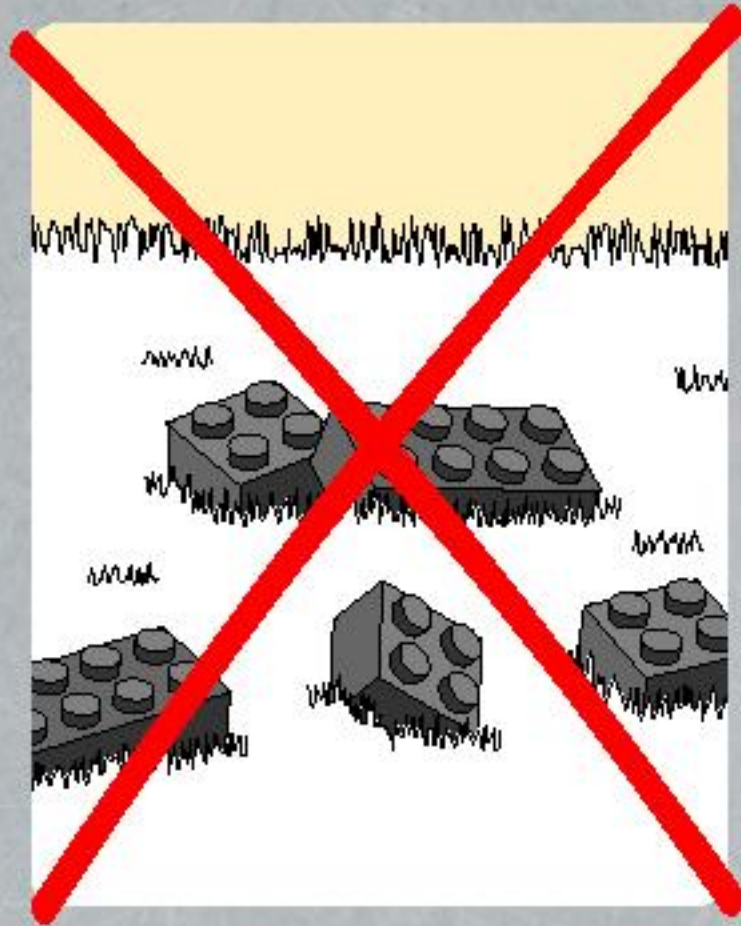

2





1

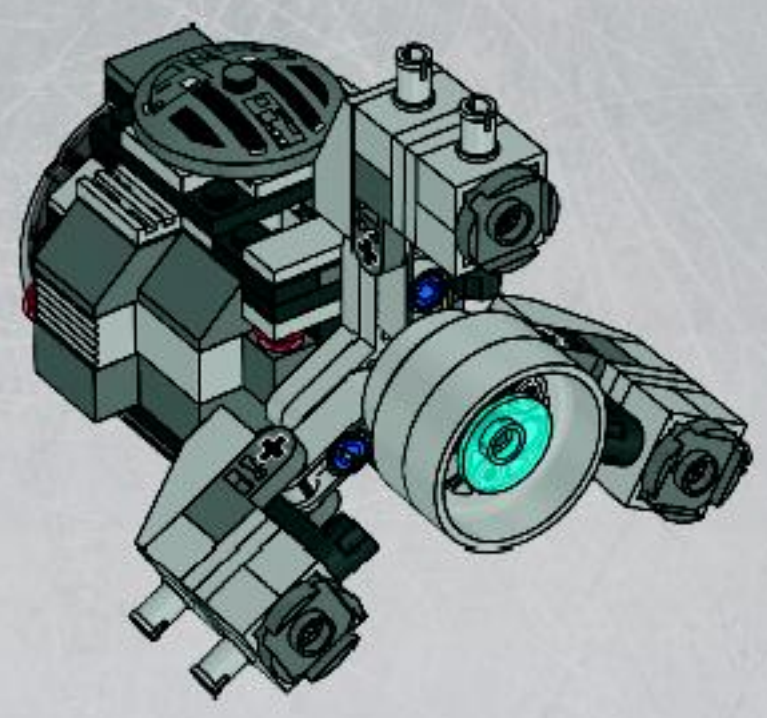

2

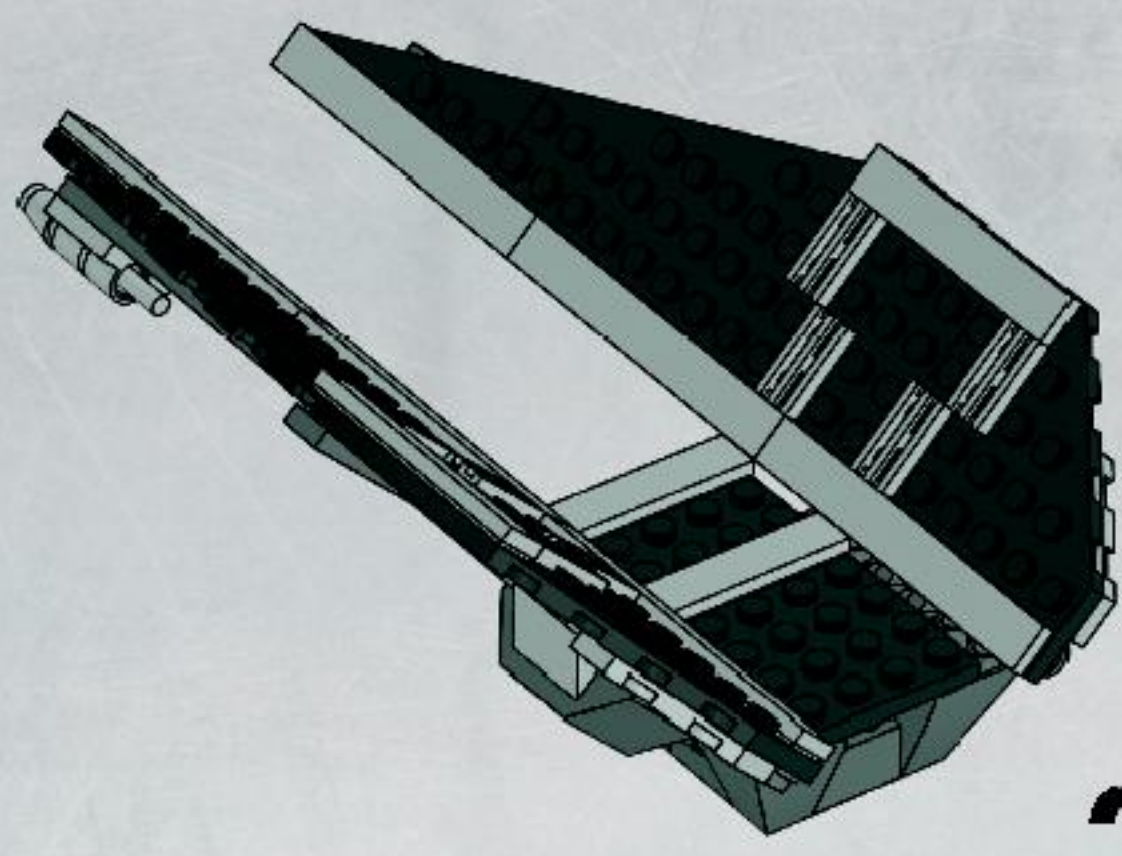

3x

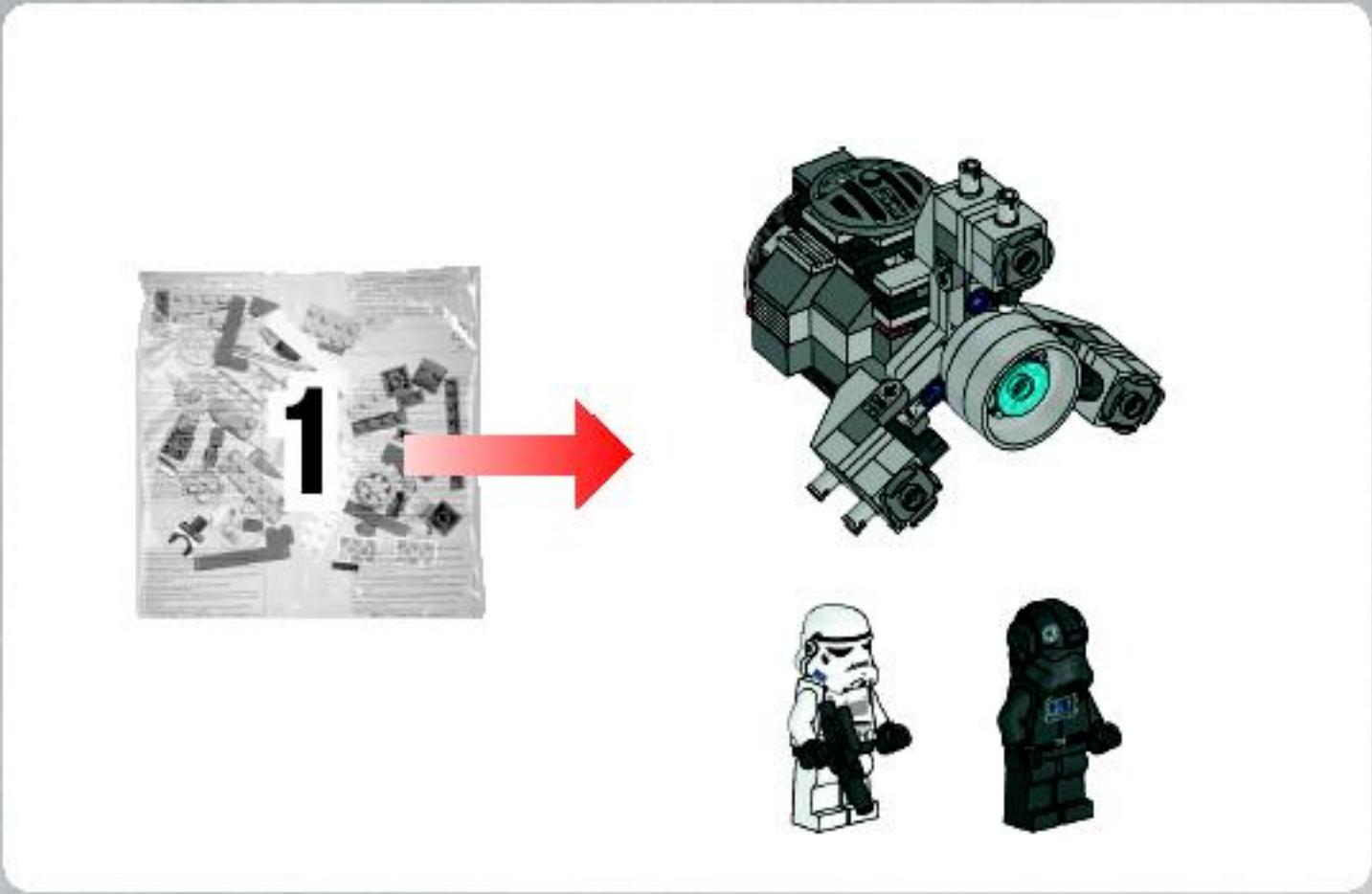

3

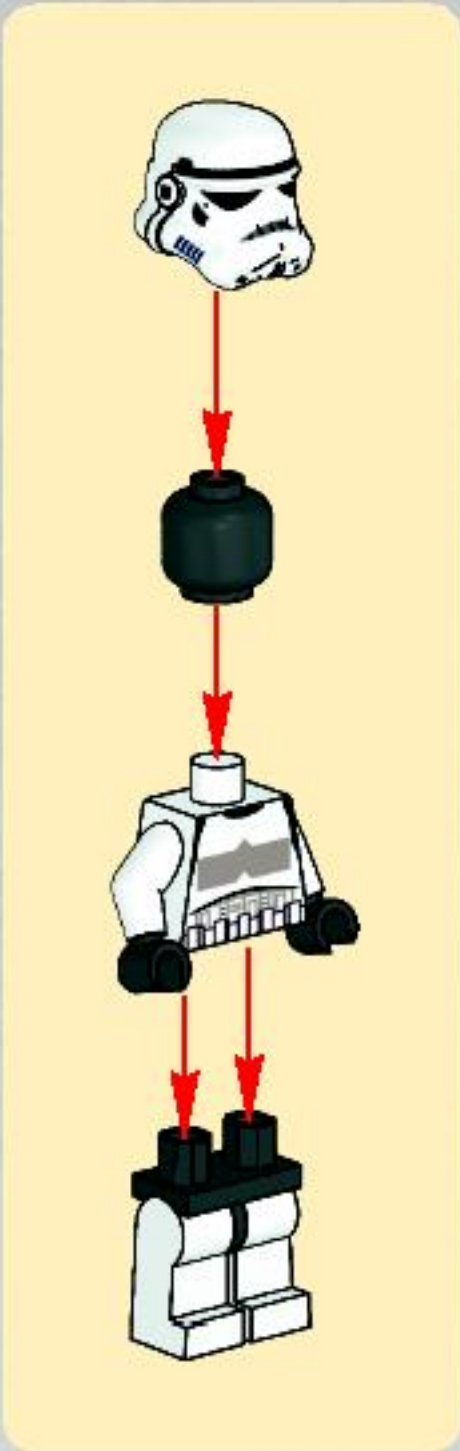

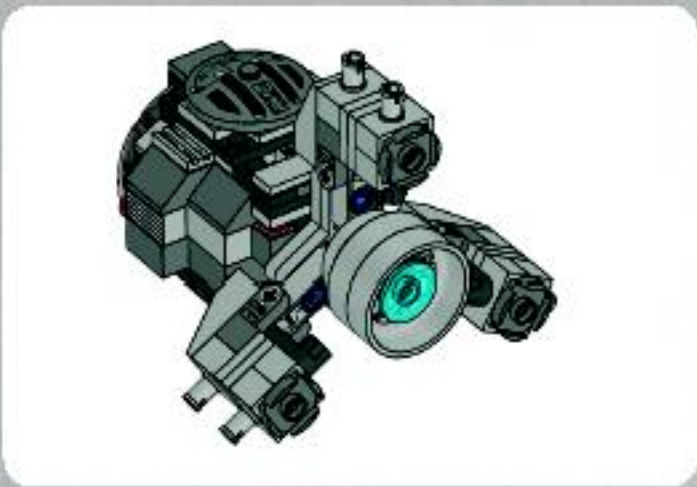

2

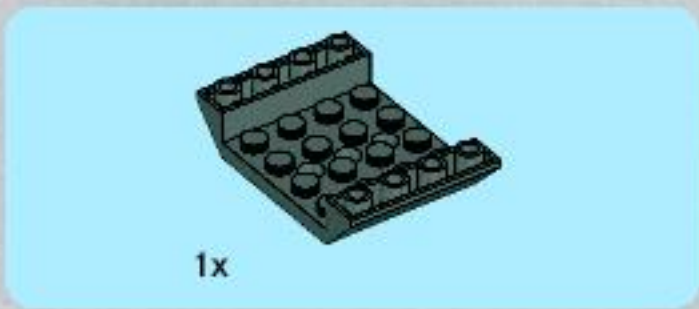
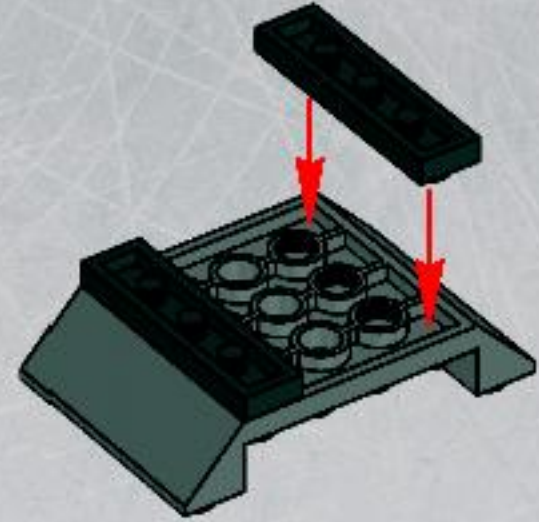

1

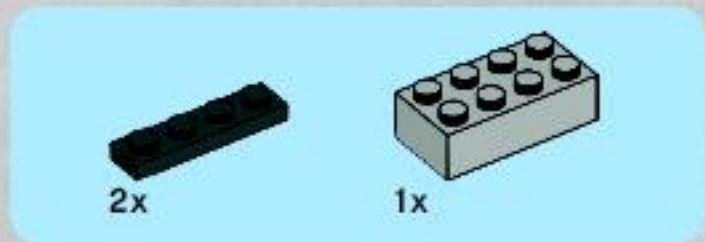
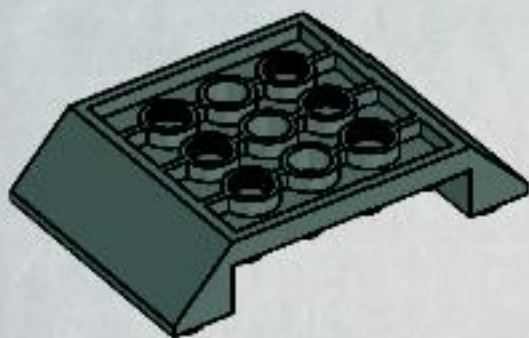

3

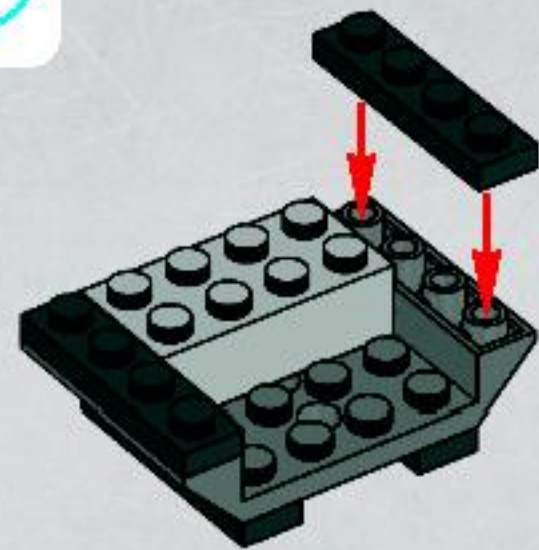



2x



1x

4

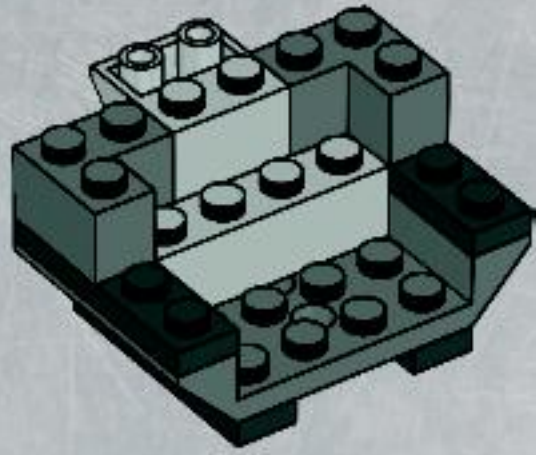

1x



2x

5

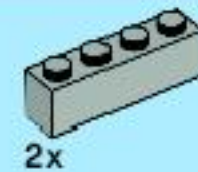
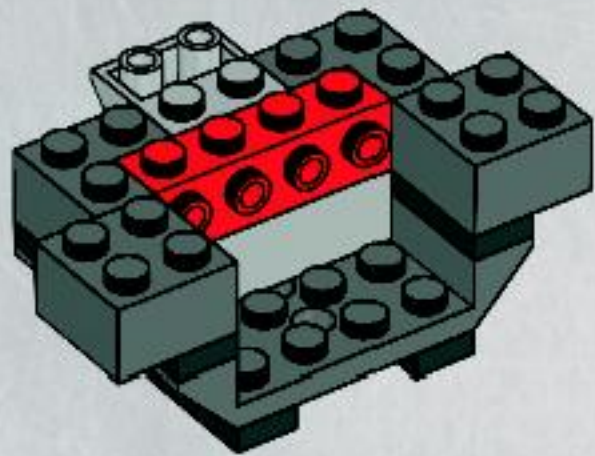

2x

6

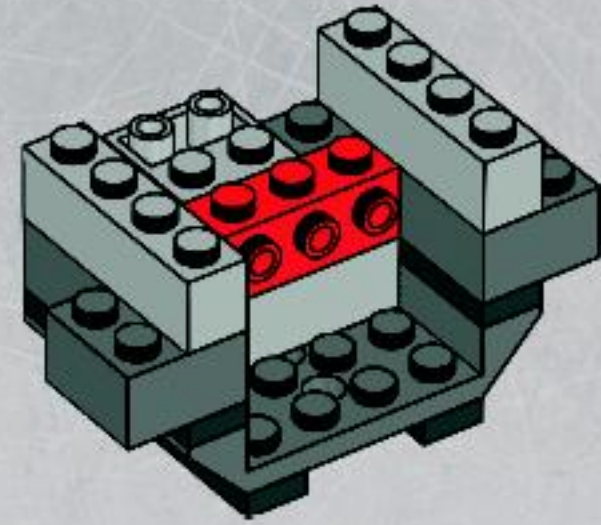

2x



2x

7

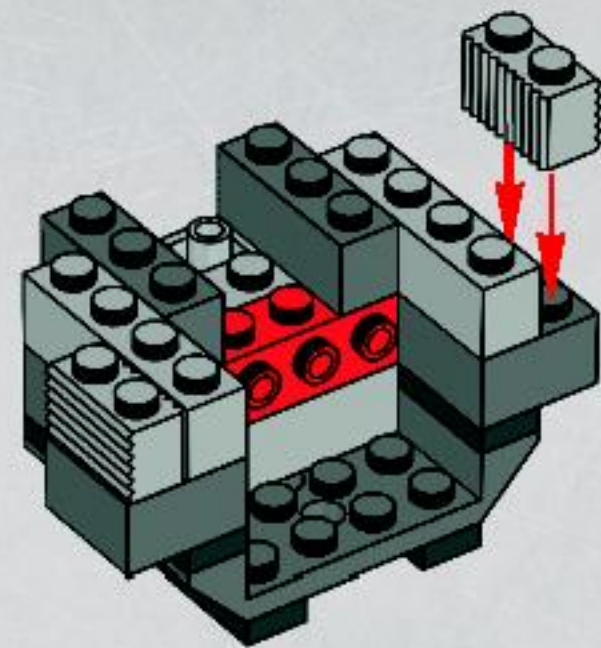

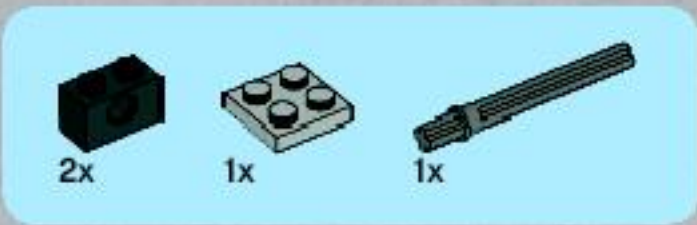

8

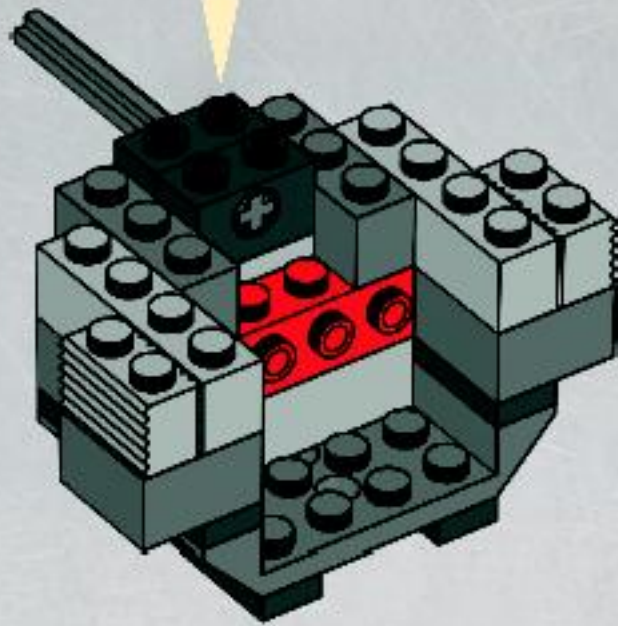
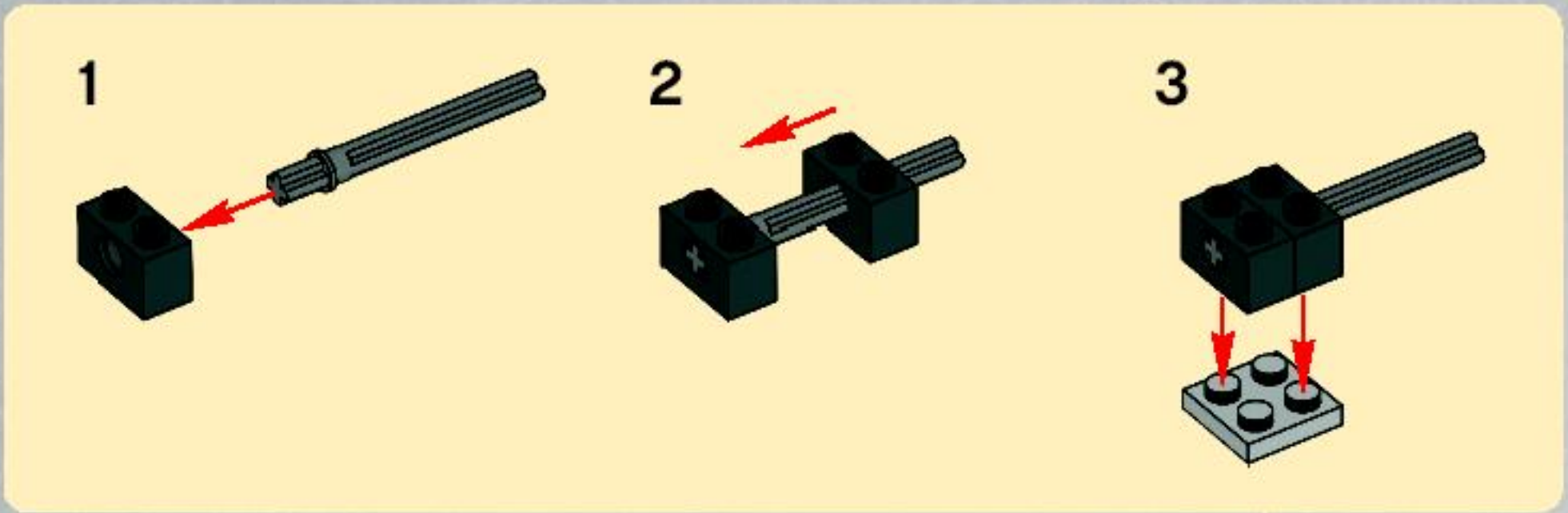



2x

9

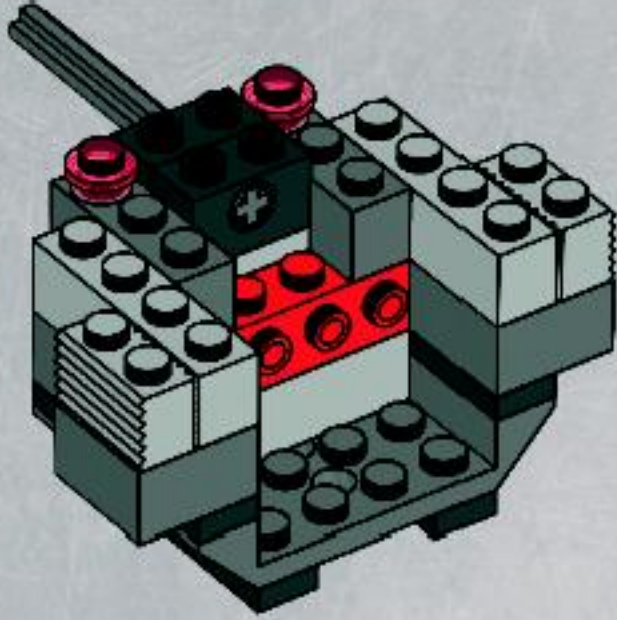

2x

10

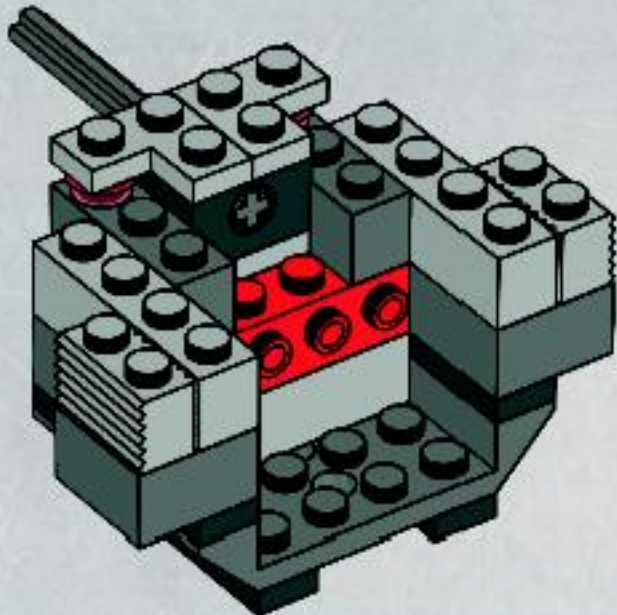

1x



2x

11

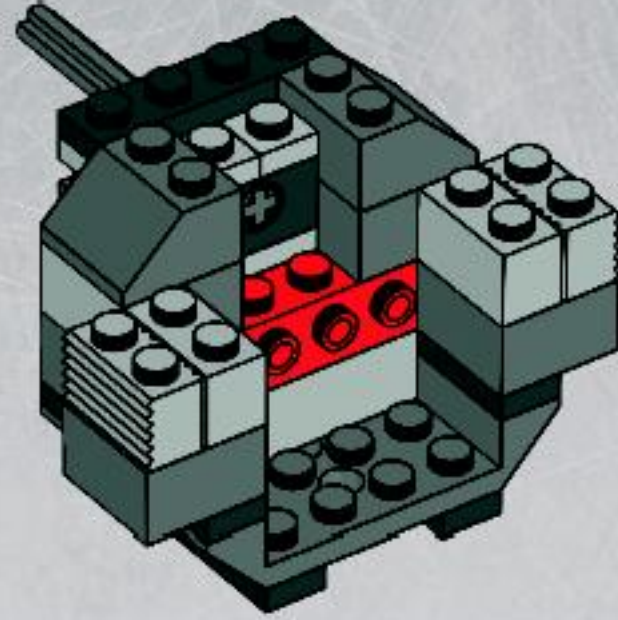

2x

12

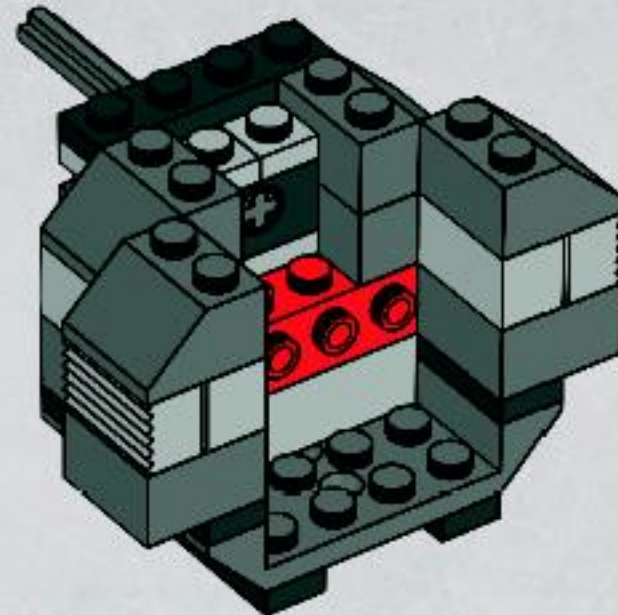



2x



1x



2x

13

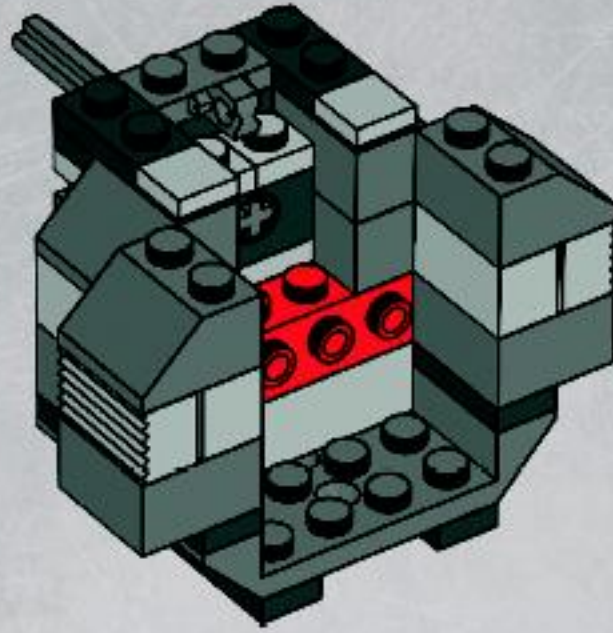

2x



1x

14

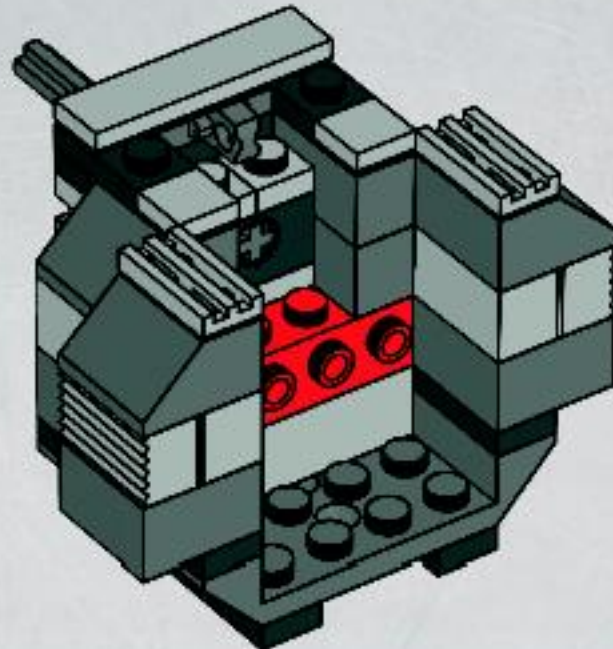



1x

15

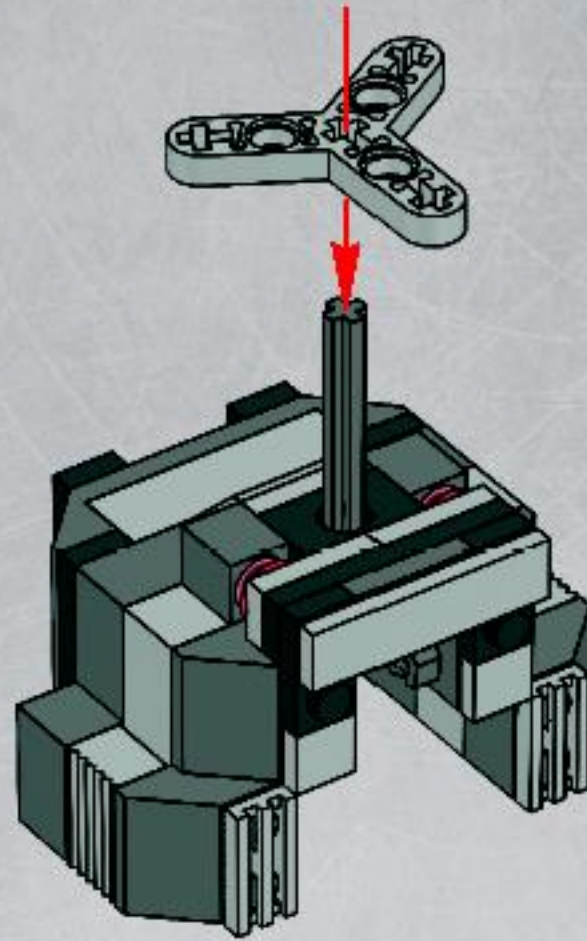

1x

16

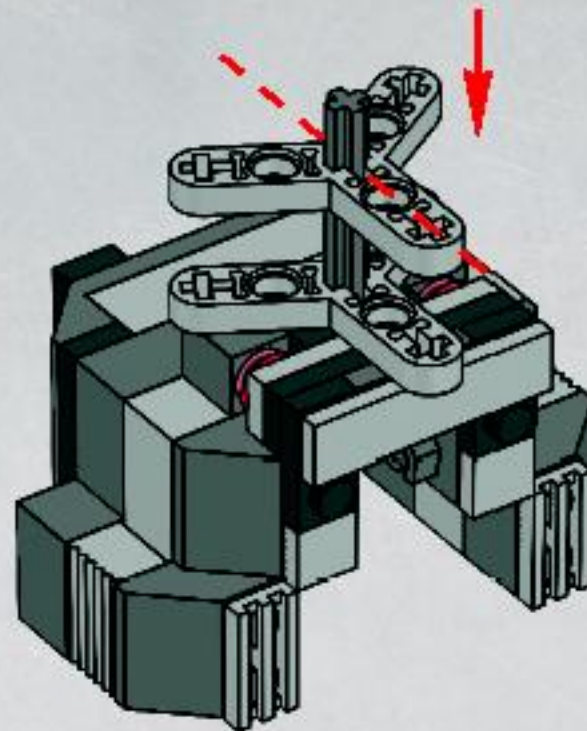
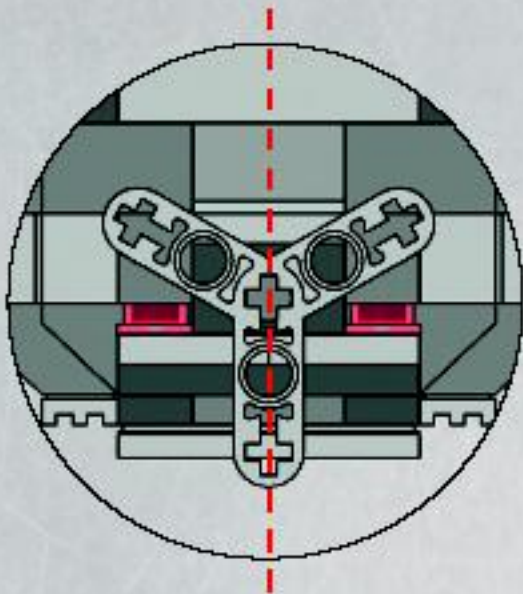



3x

17

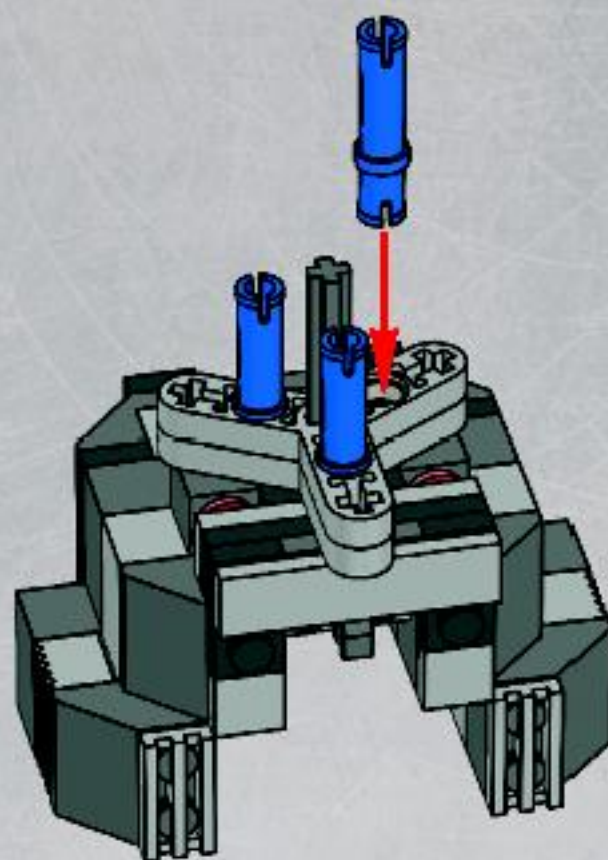

3x

18

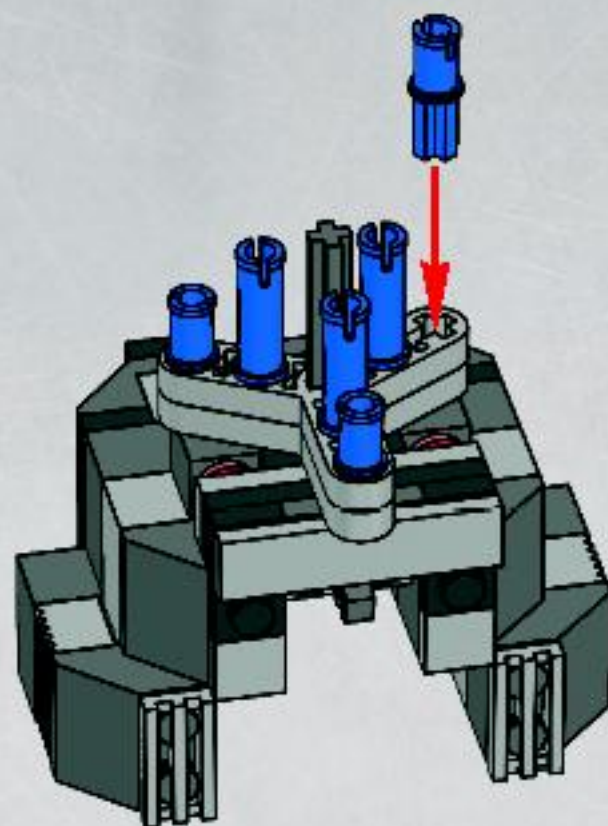



3x

19

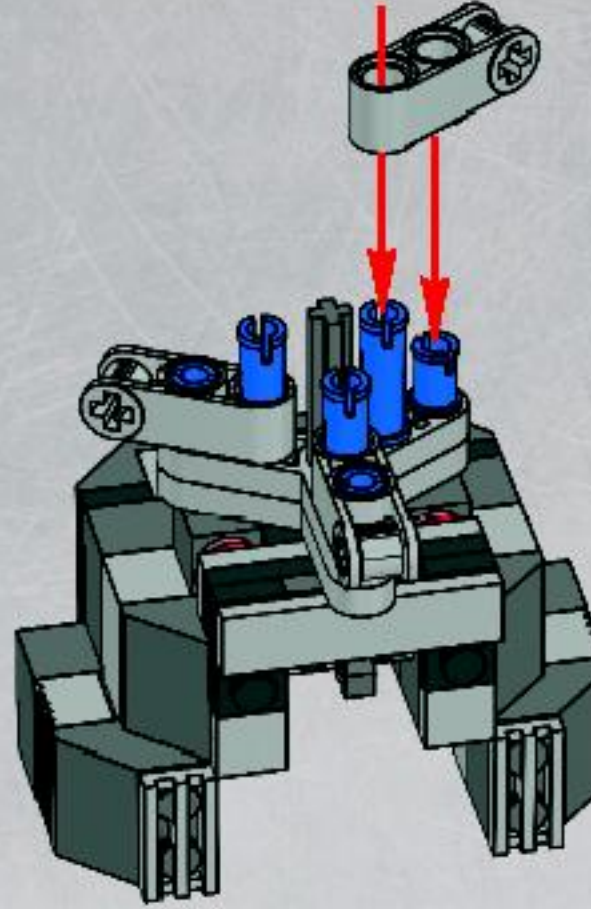

1x

20

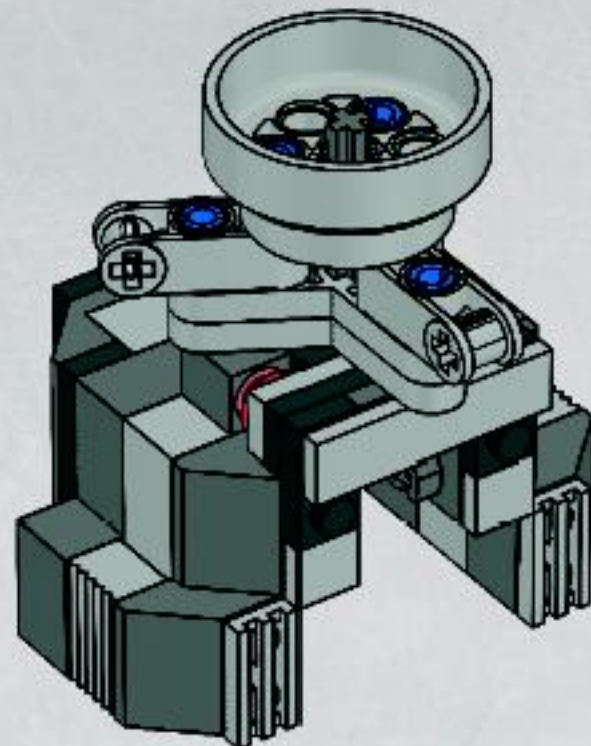



3x

21

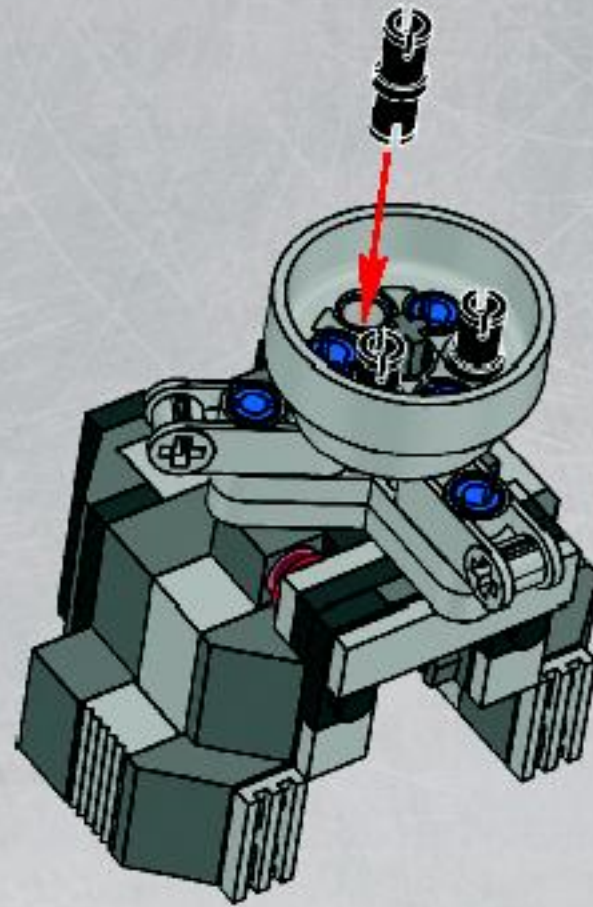

1x

22

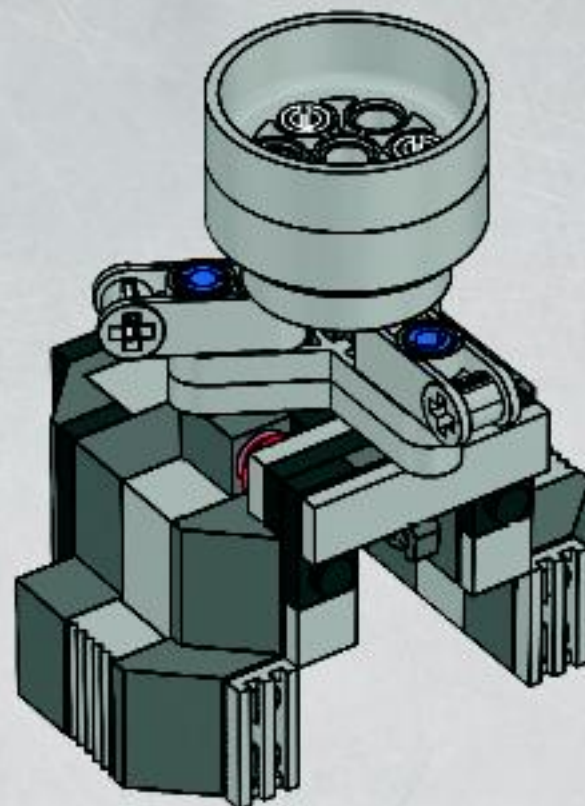



23

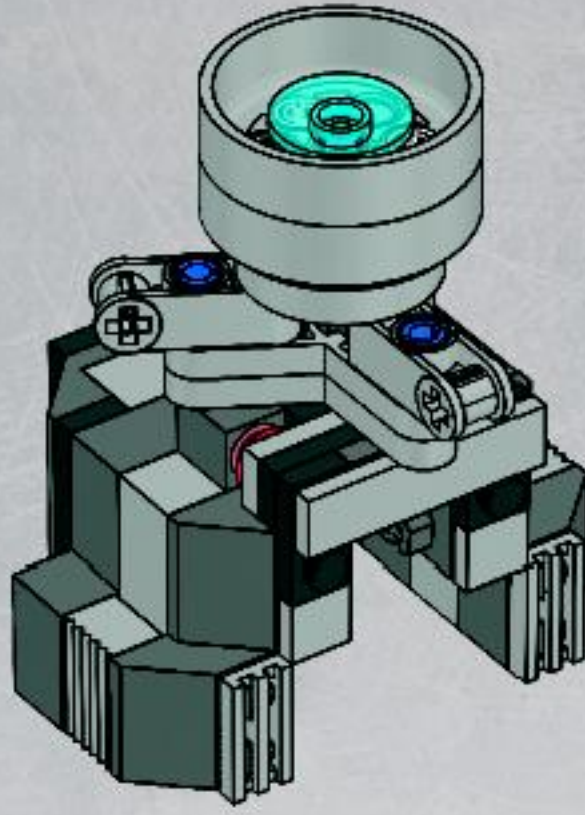

24

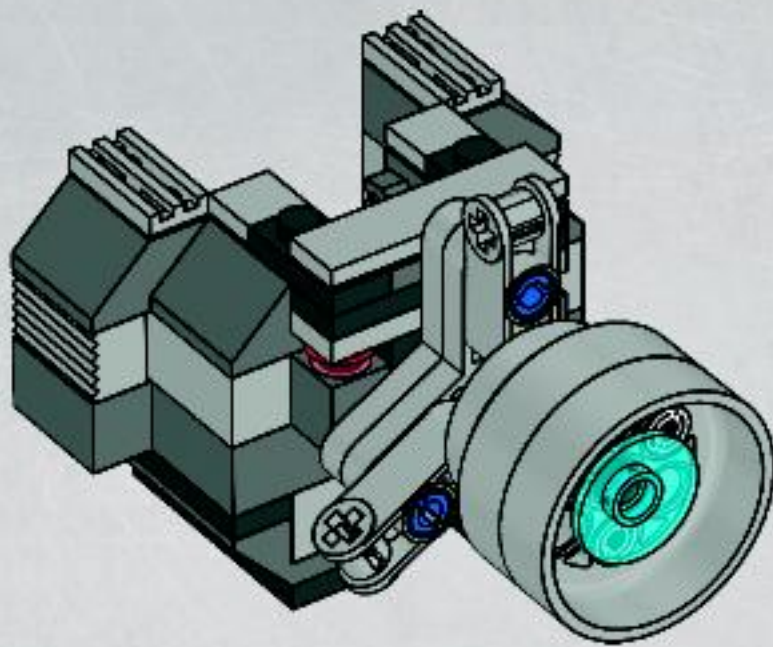



1x

1



1x



1x

2



1x



1x

3

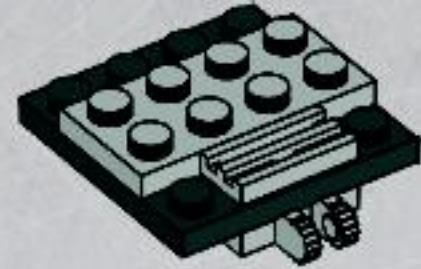

1x

4

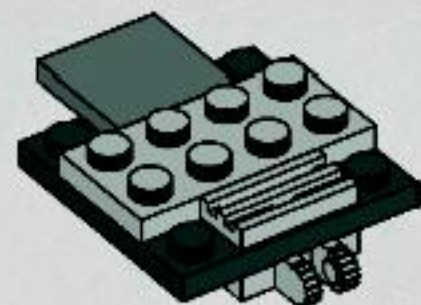



1x



1x

5

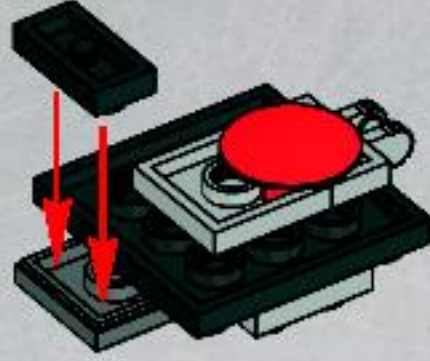

1x

6



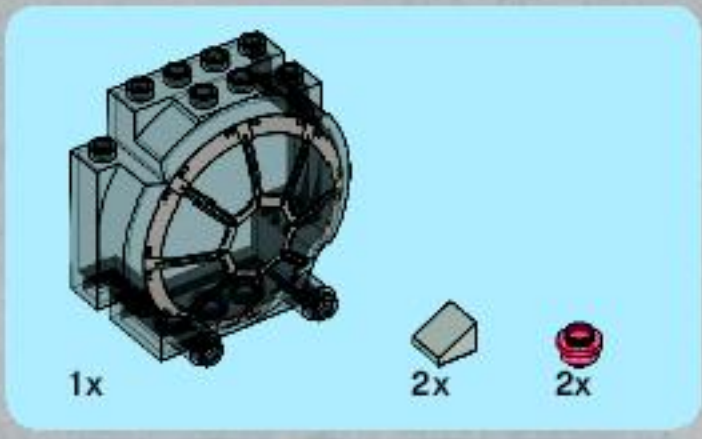

7

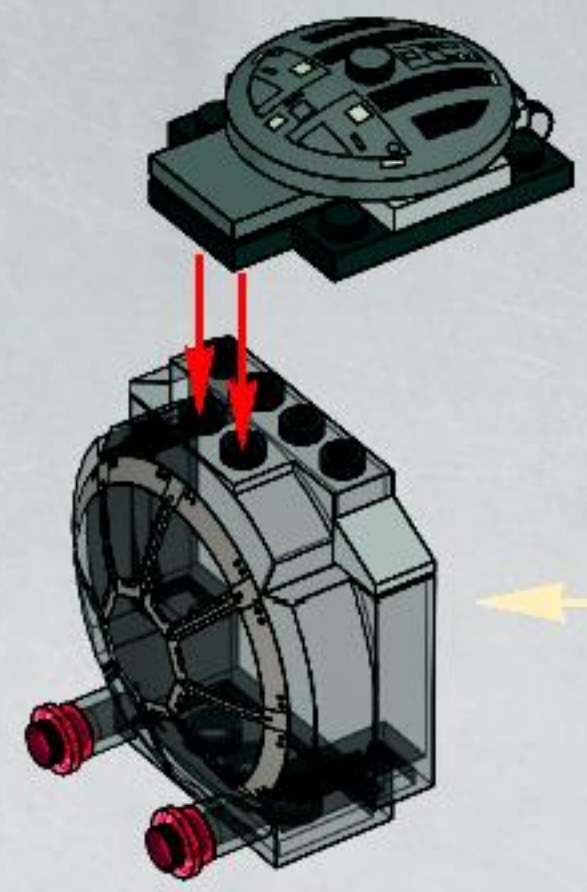
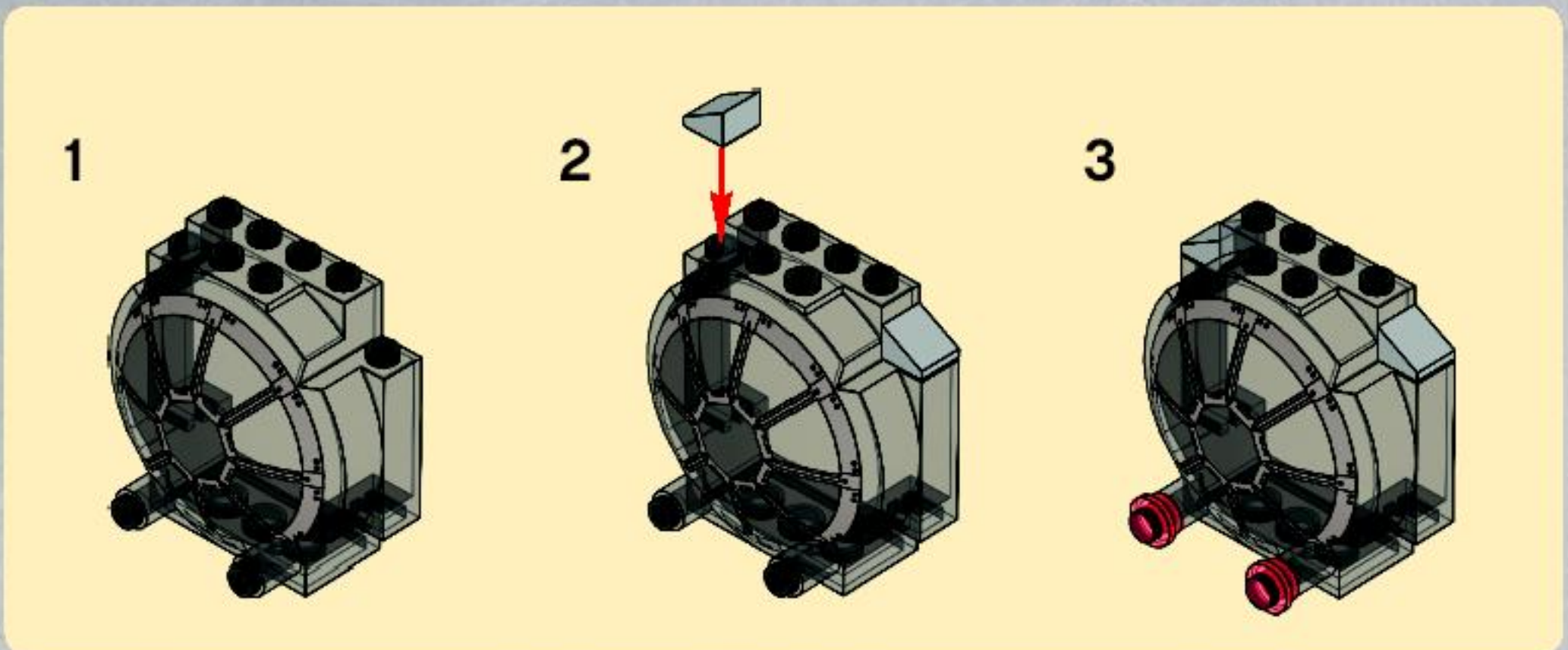

8

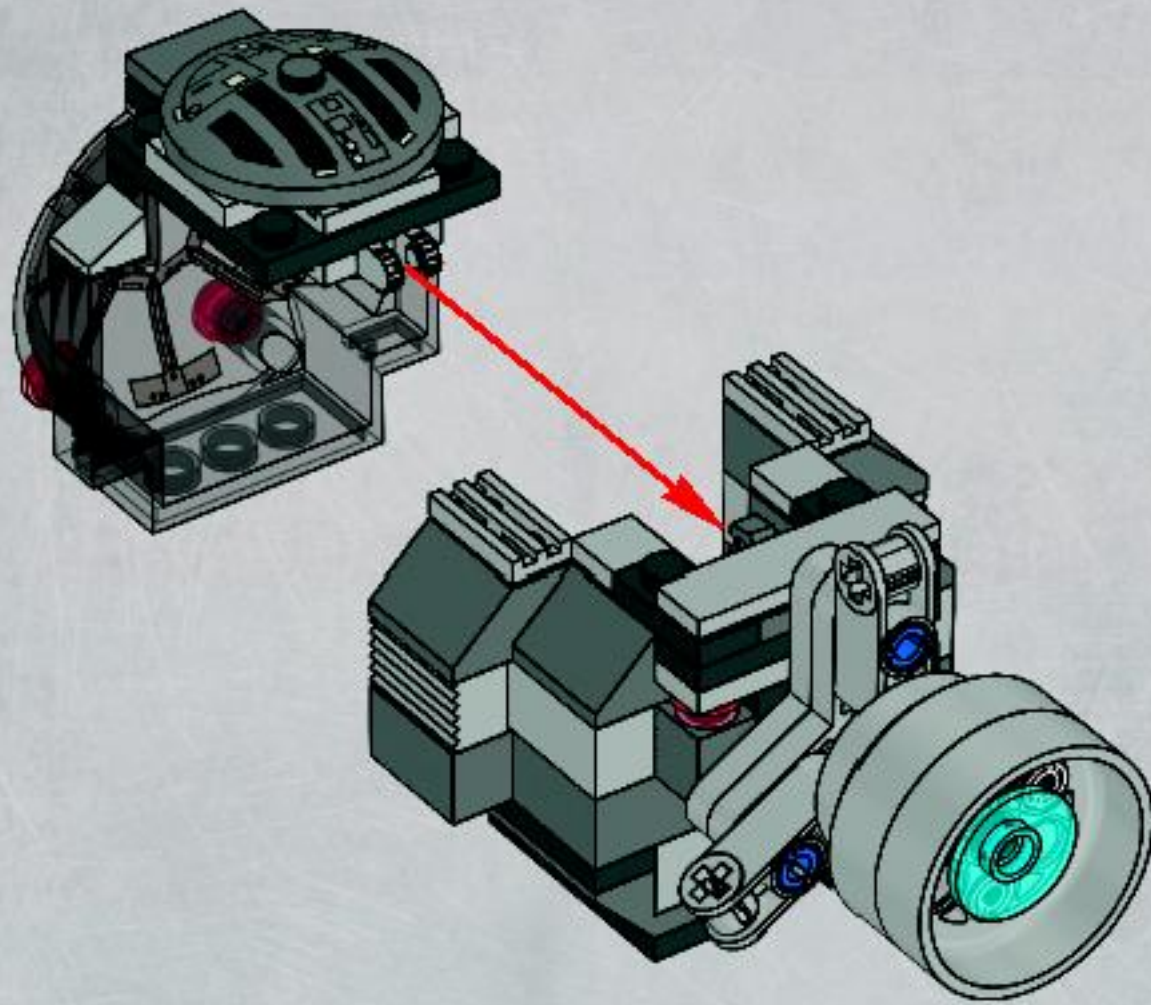



3x



6x



3x

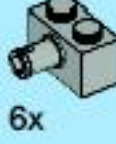

6x



3x



3x



3x



3x



6x

9

1



2



3



4

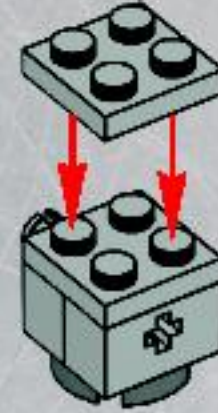

5



6

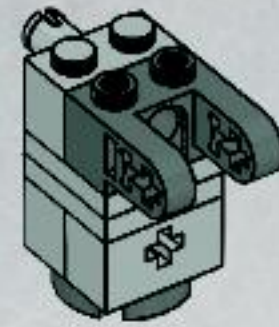

7

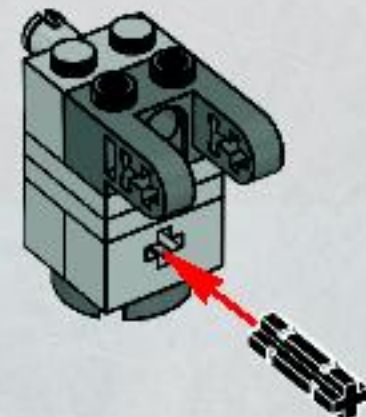

8

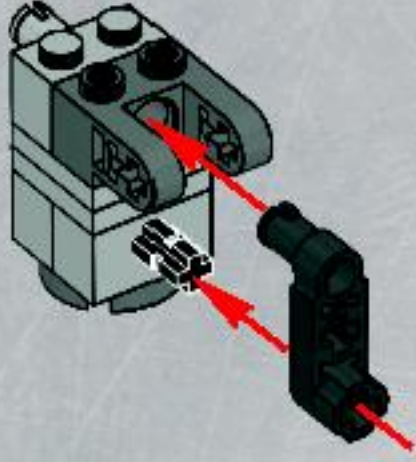

9

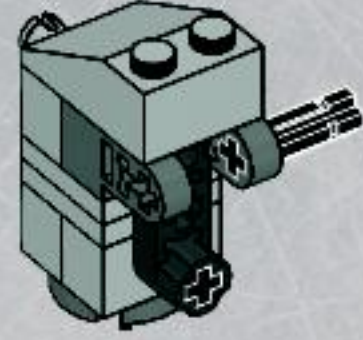

3x

10

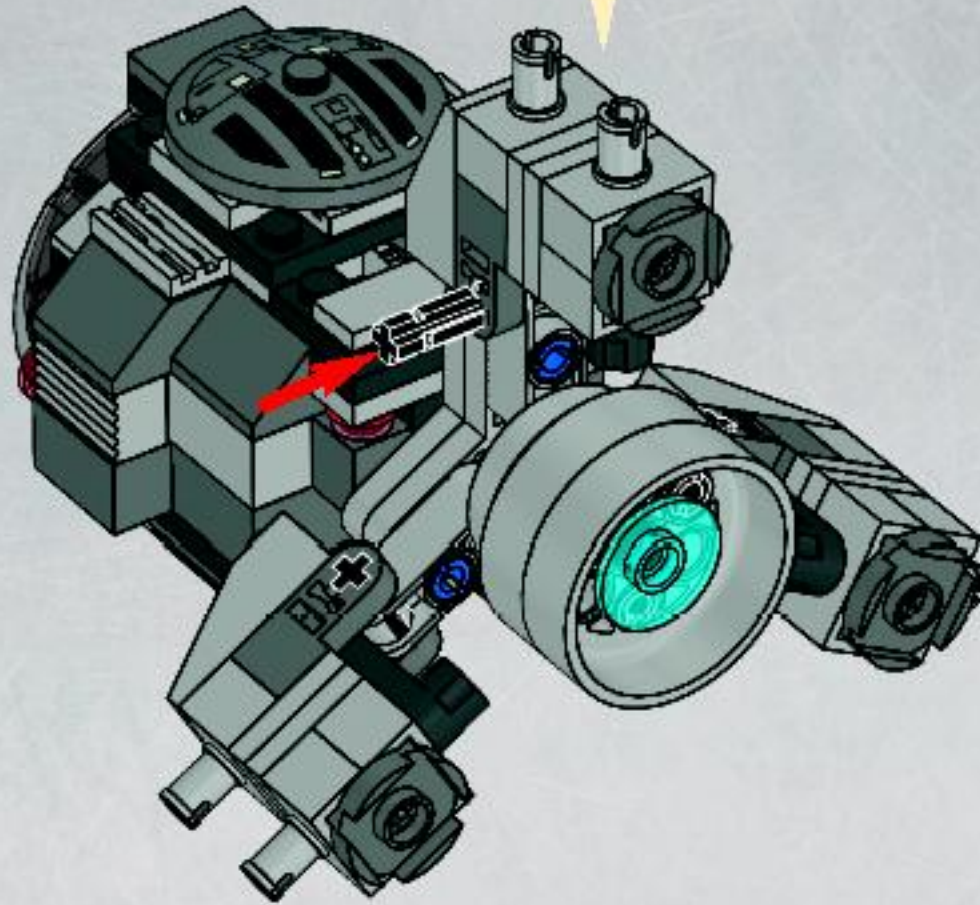



2

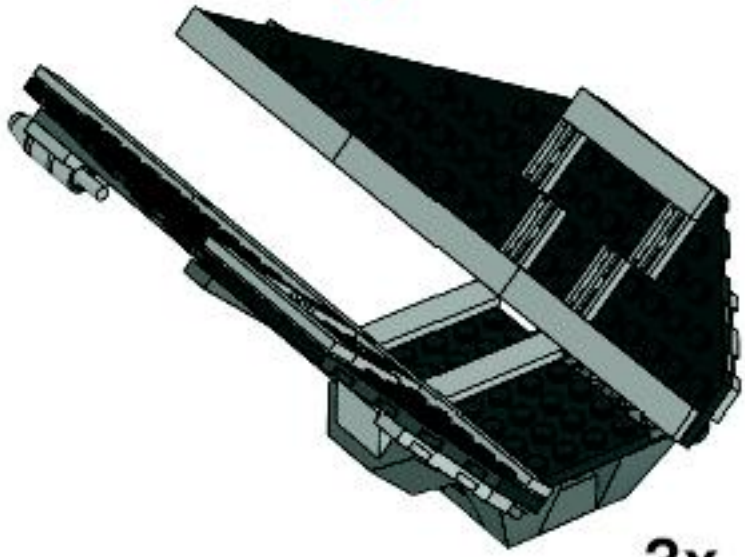

3x



2x



1x

1



1x

2



1x

3



2x

4

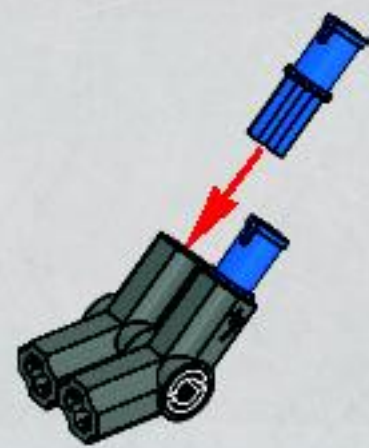



2x

5

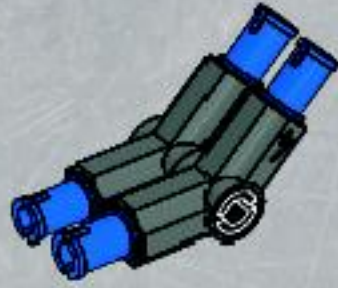

1x

6

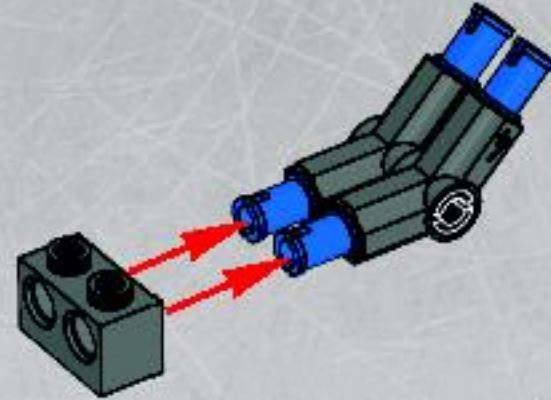

2x

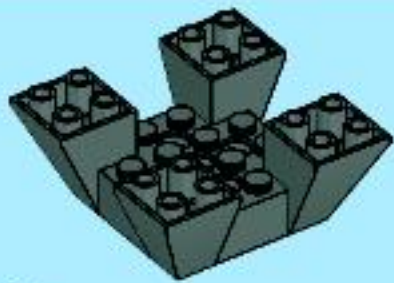

1x

7

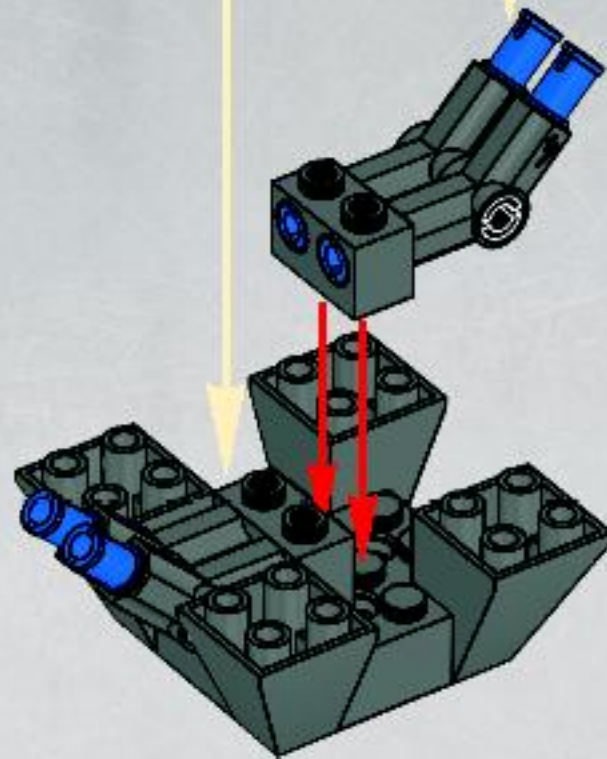



1x

8

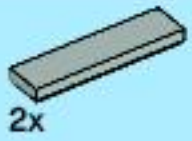
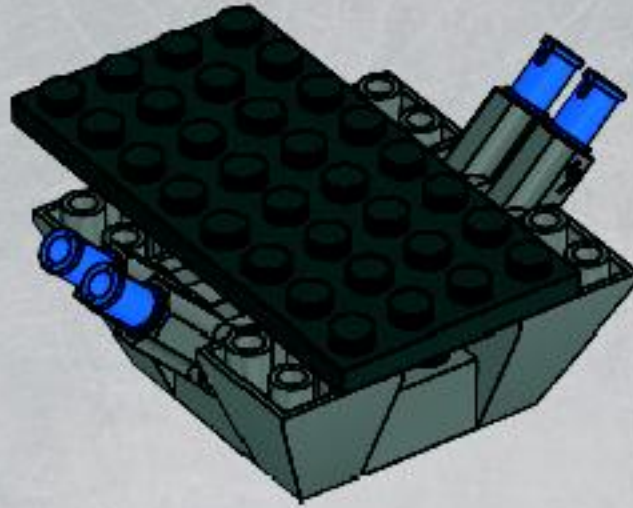

2x

9

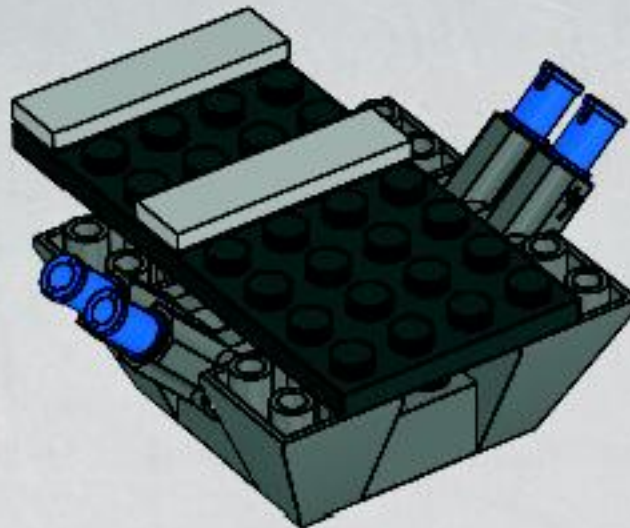

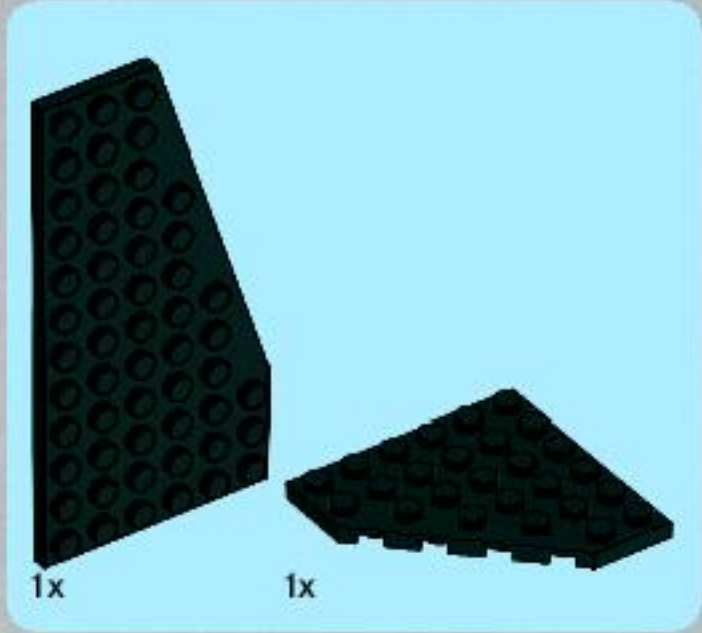
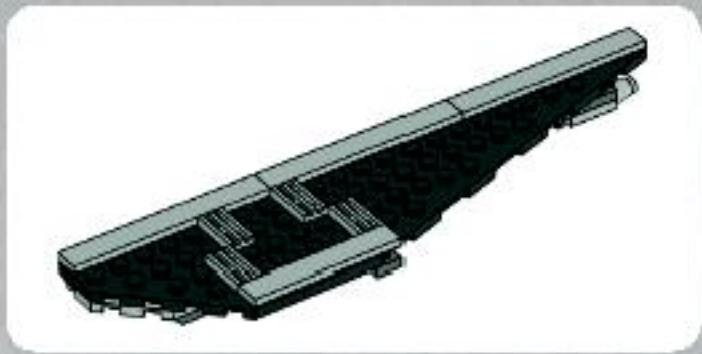

1

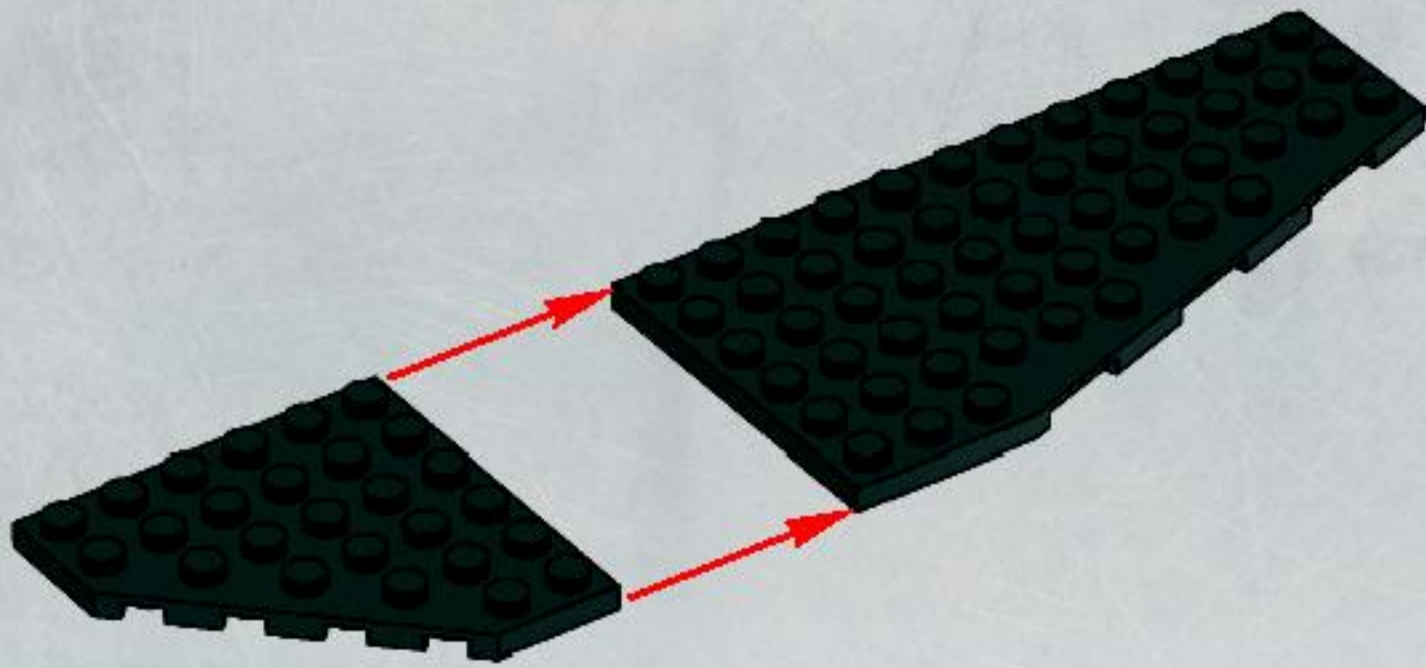

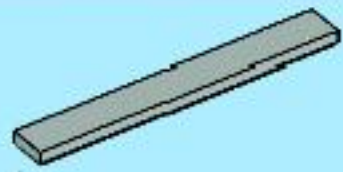

1x

2

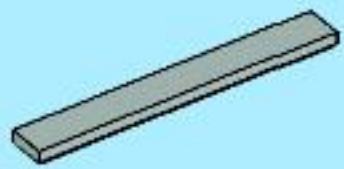
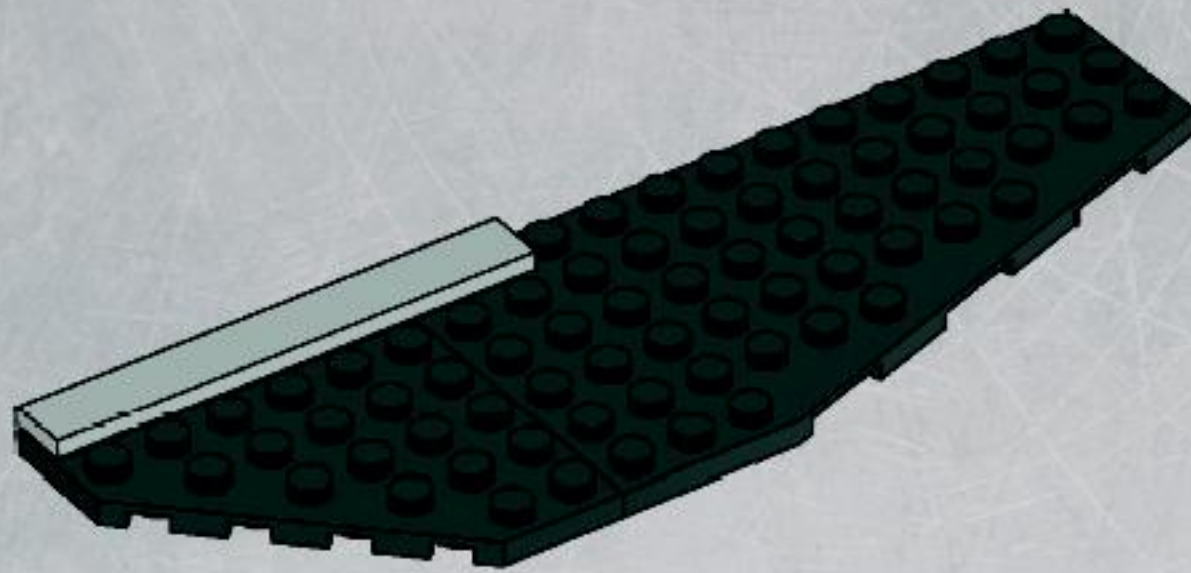

1x



1x

3

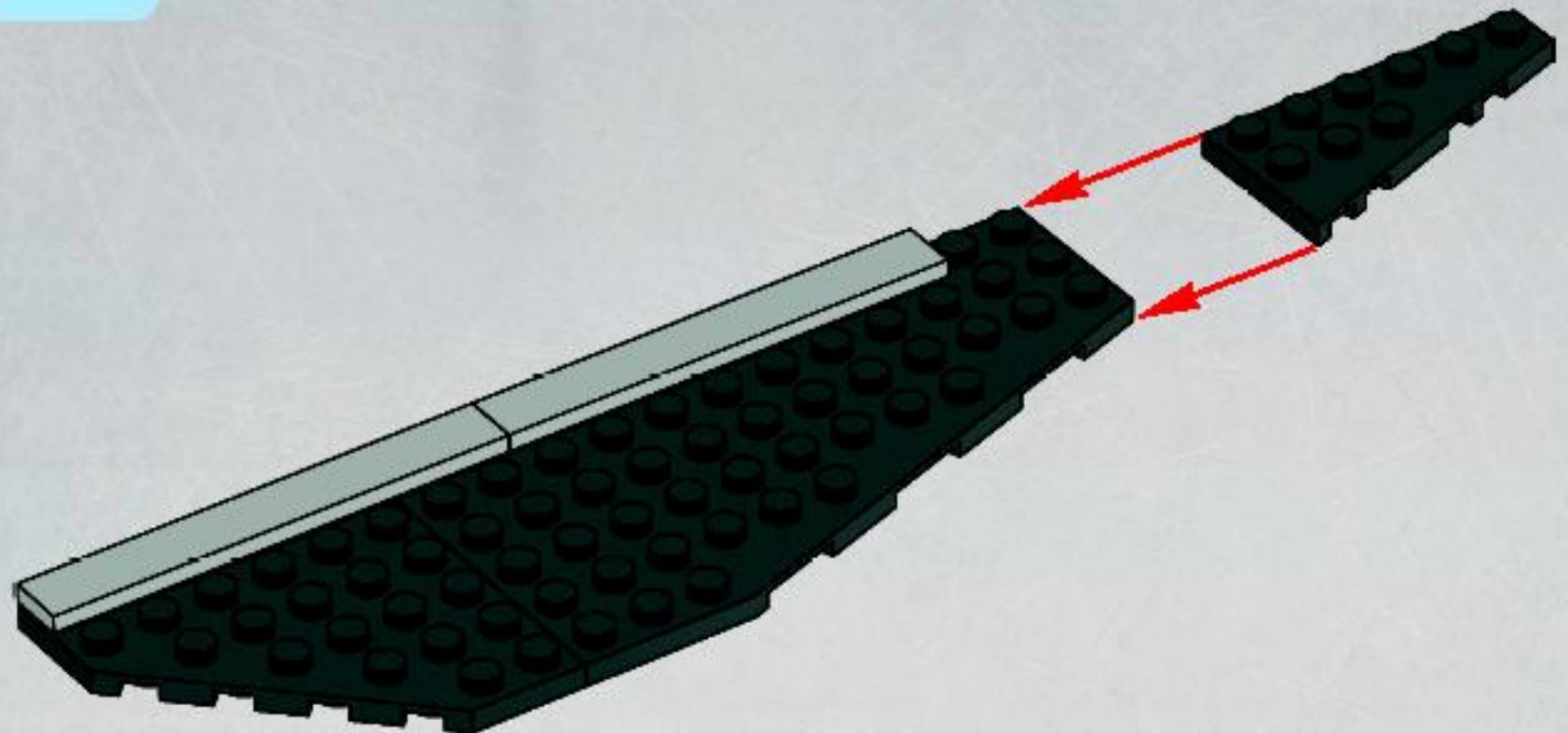

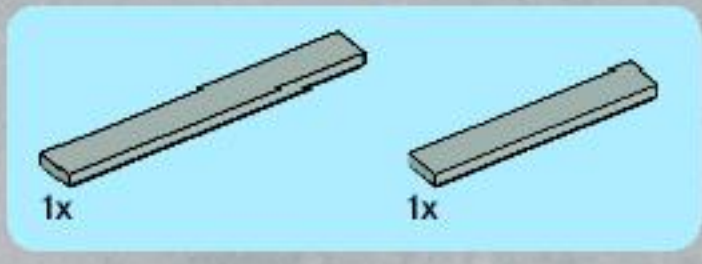

4

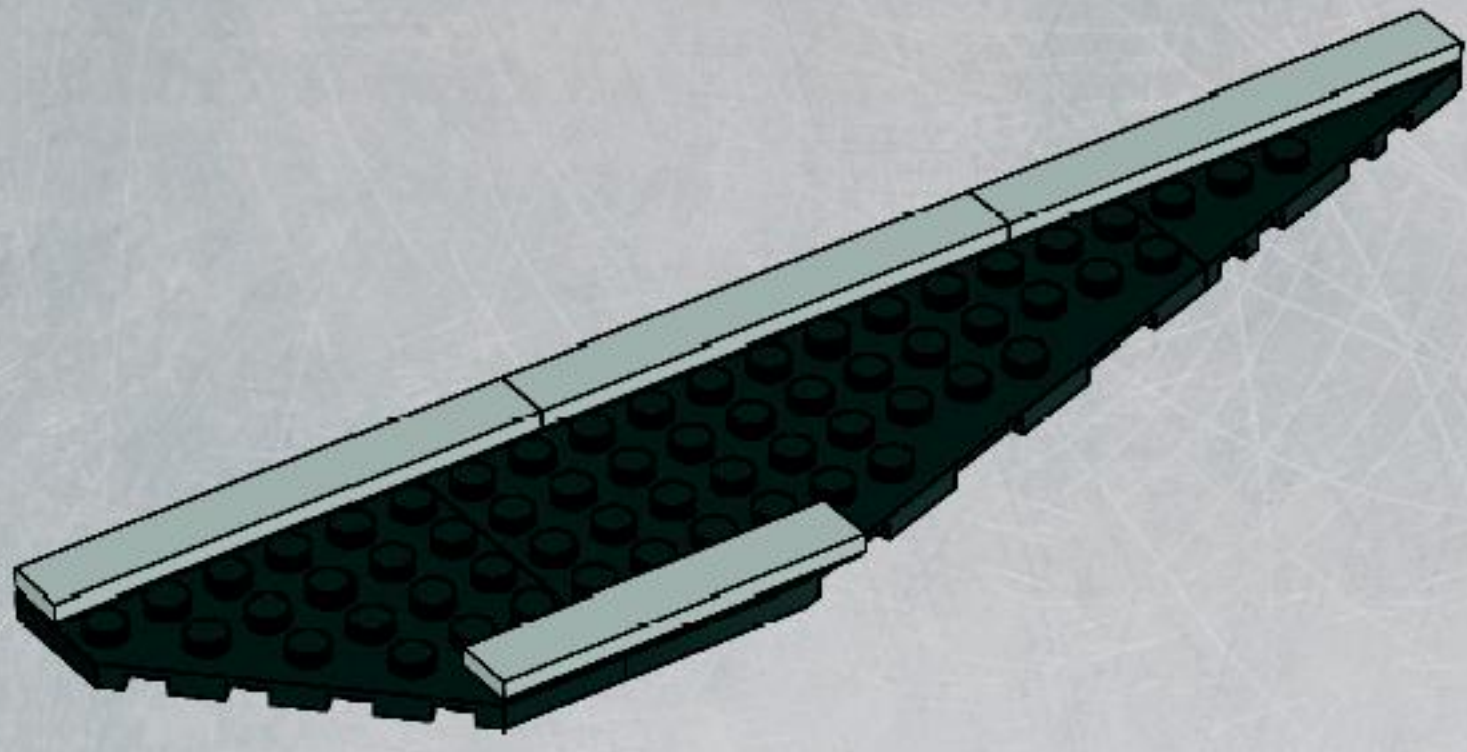

5

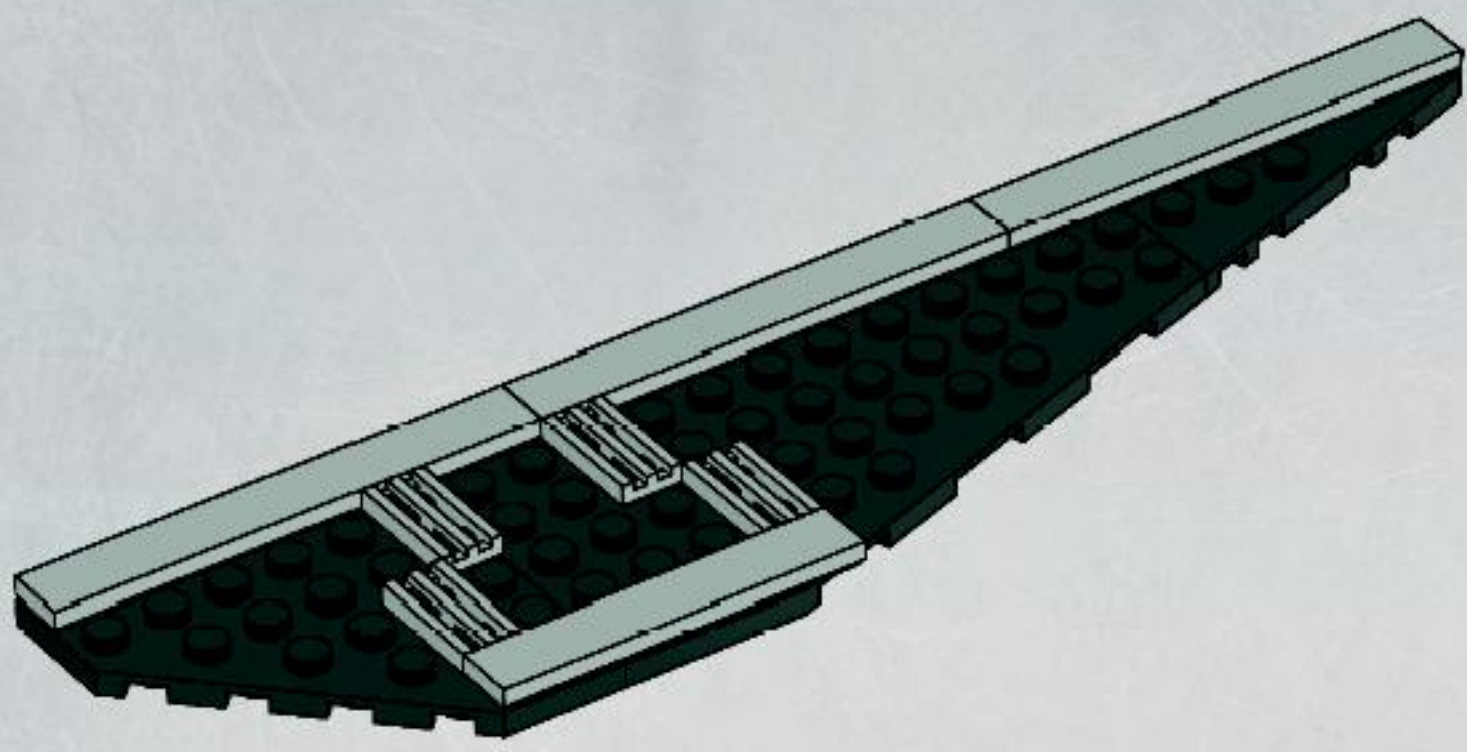



1x

6

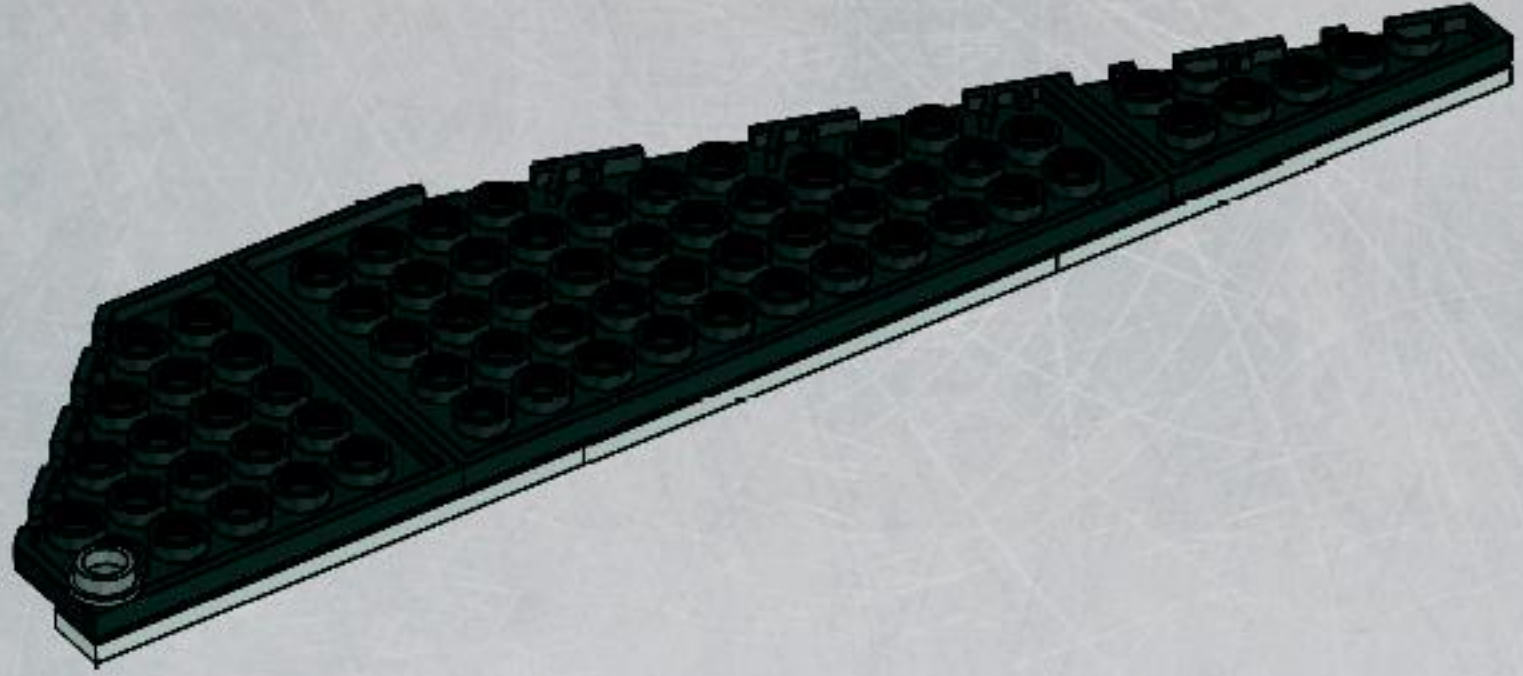

1x



1x

7

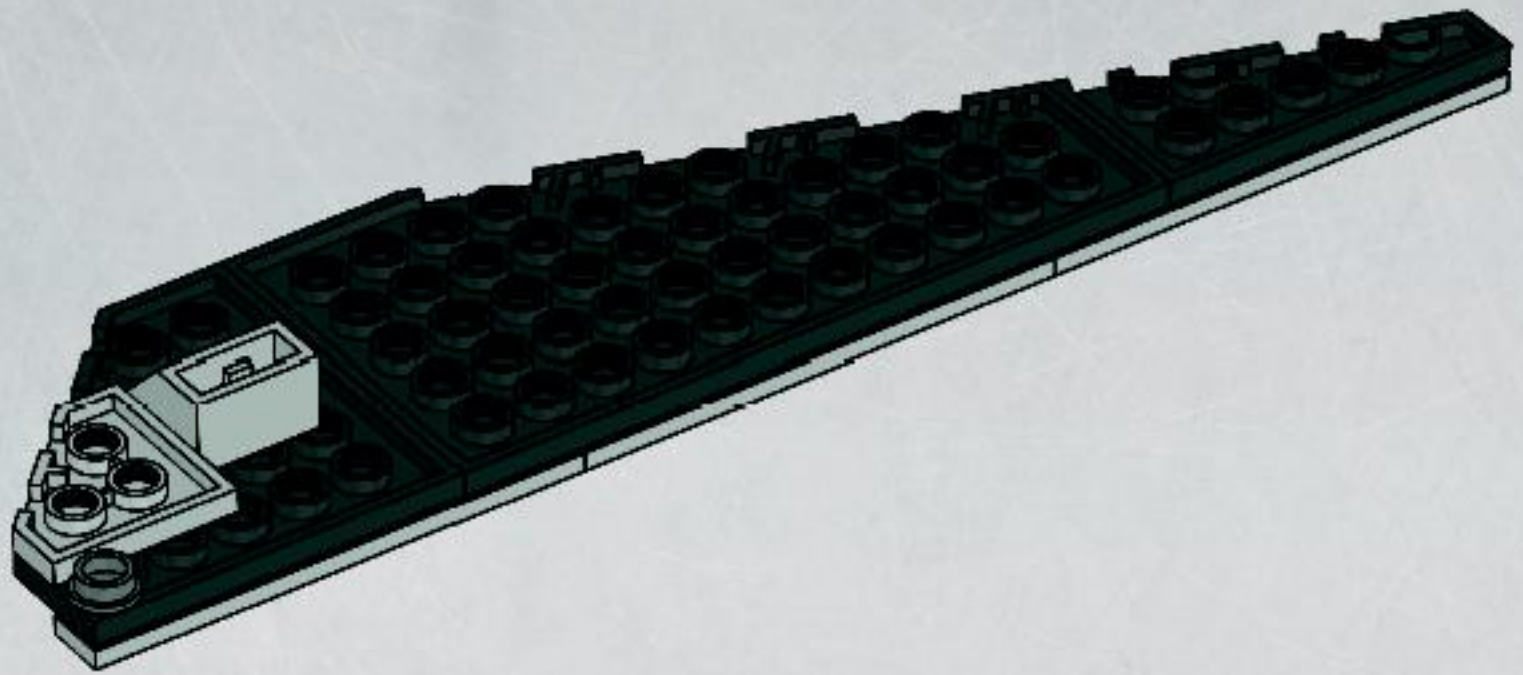



1x

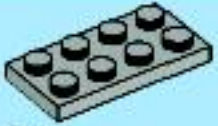

1x

8

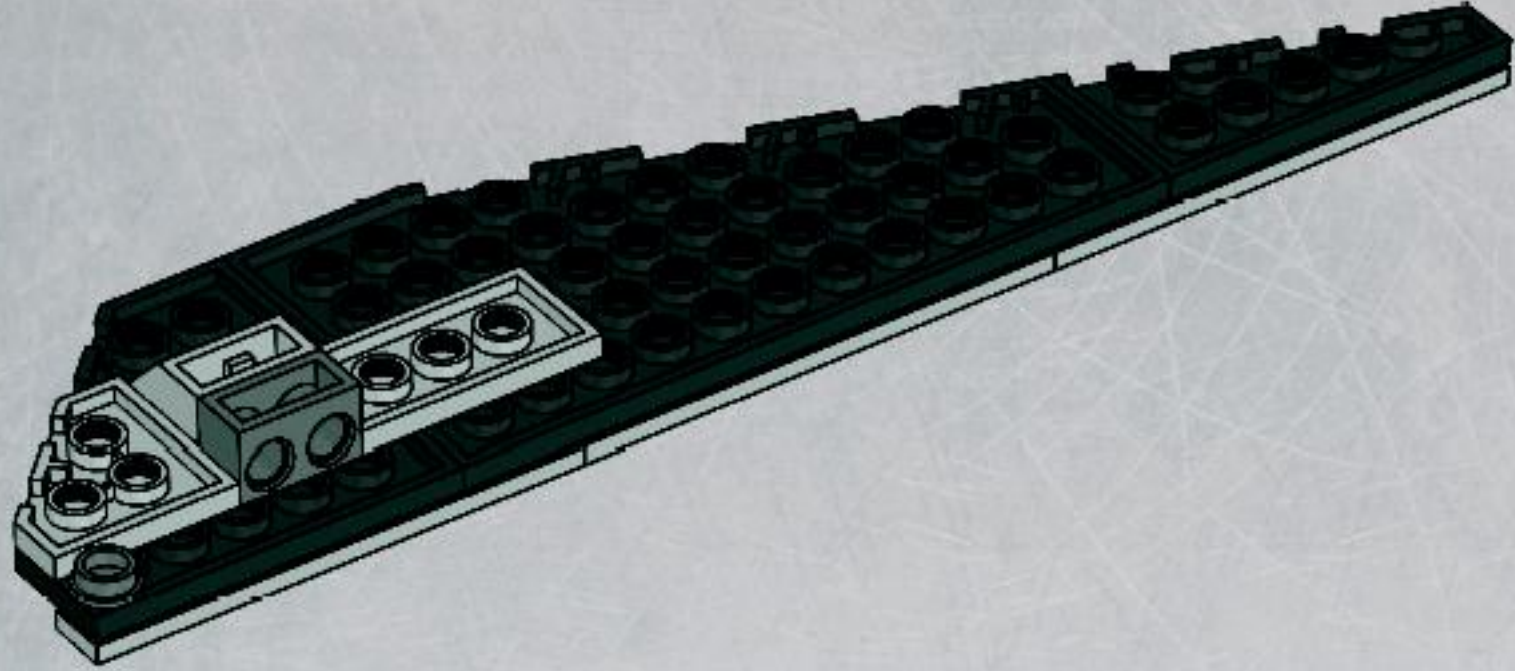

1x

9

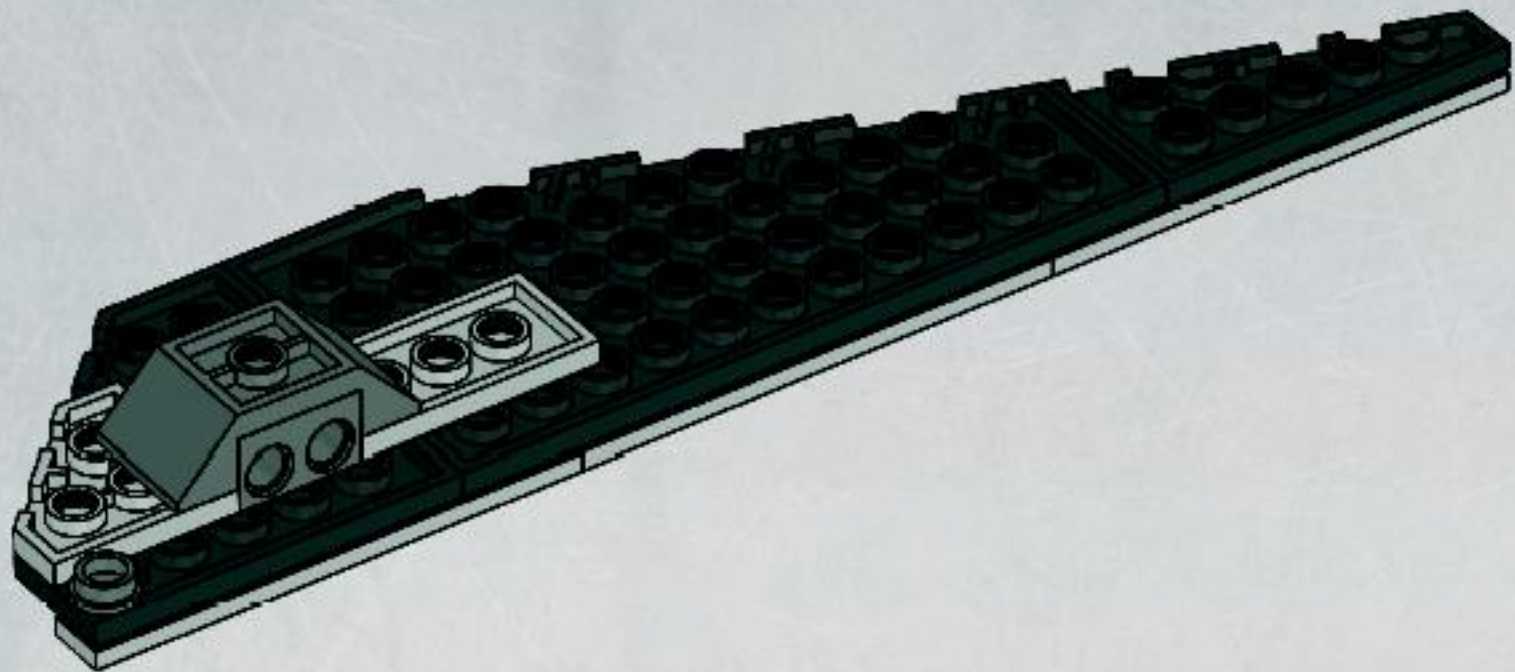

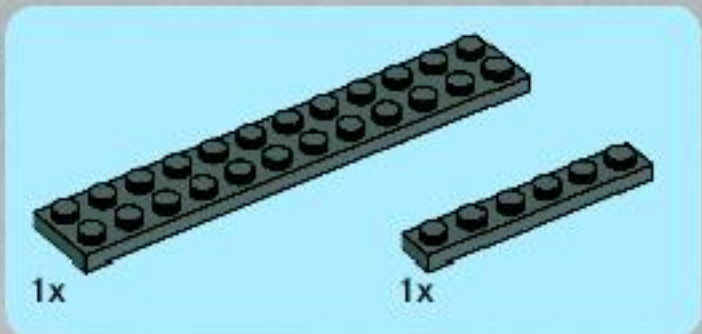

10

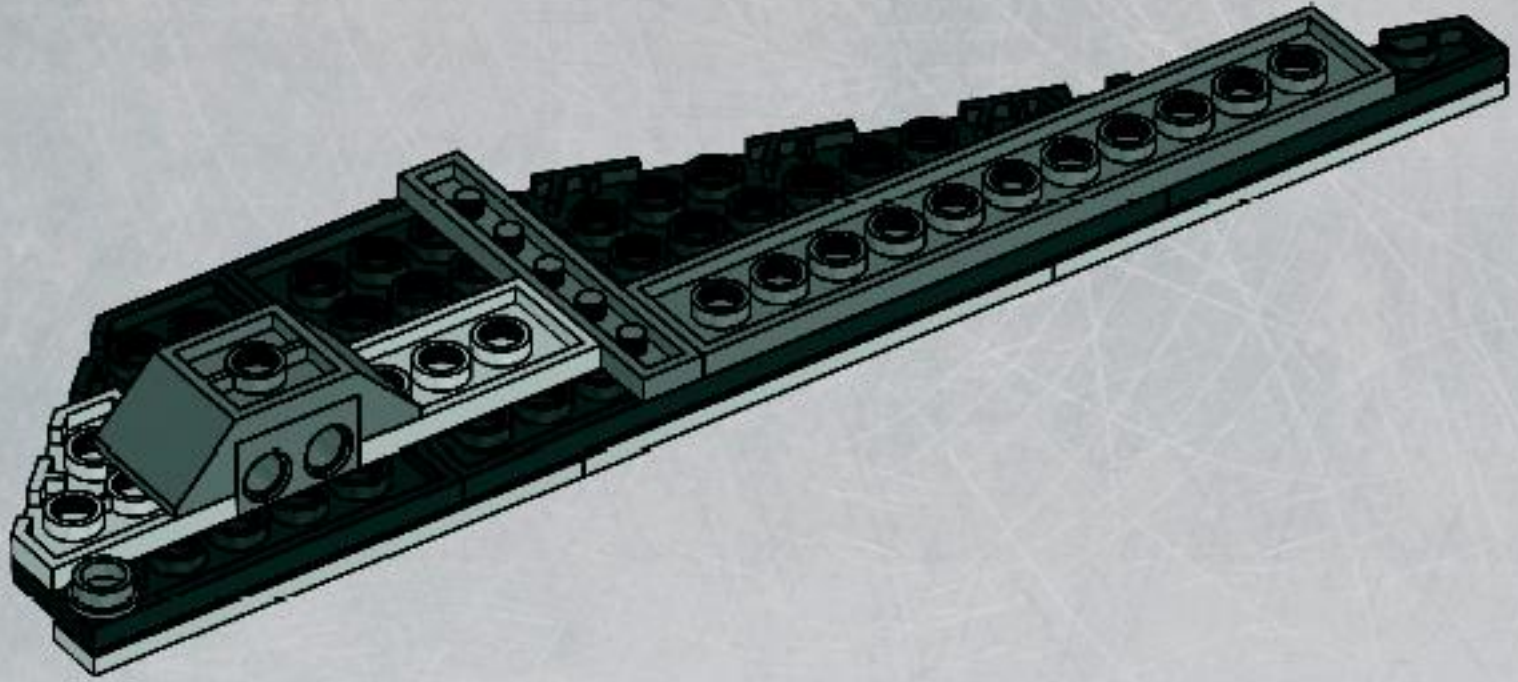

11

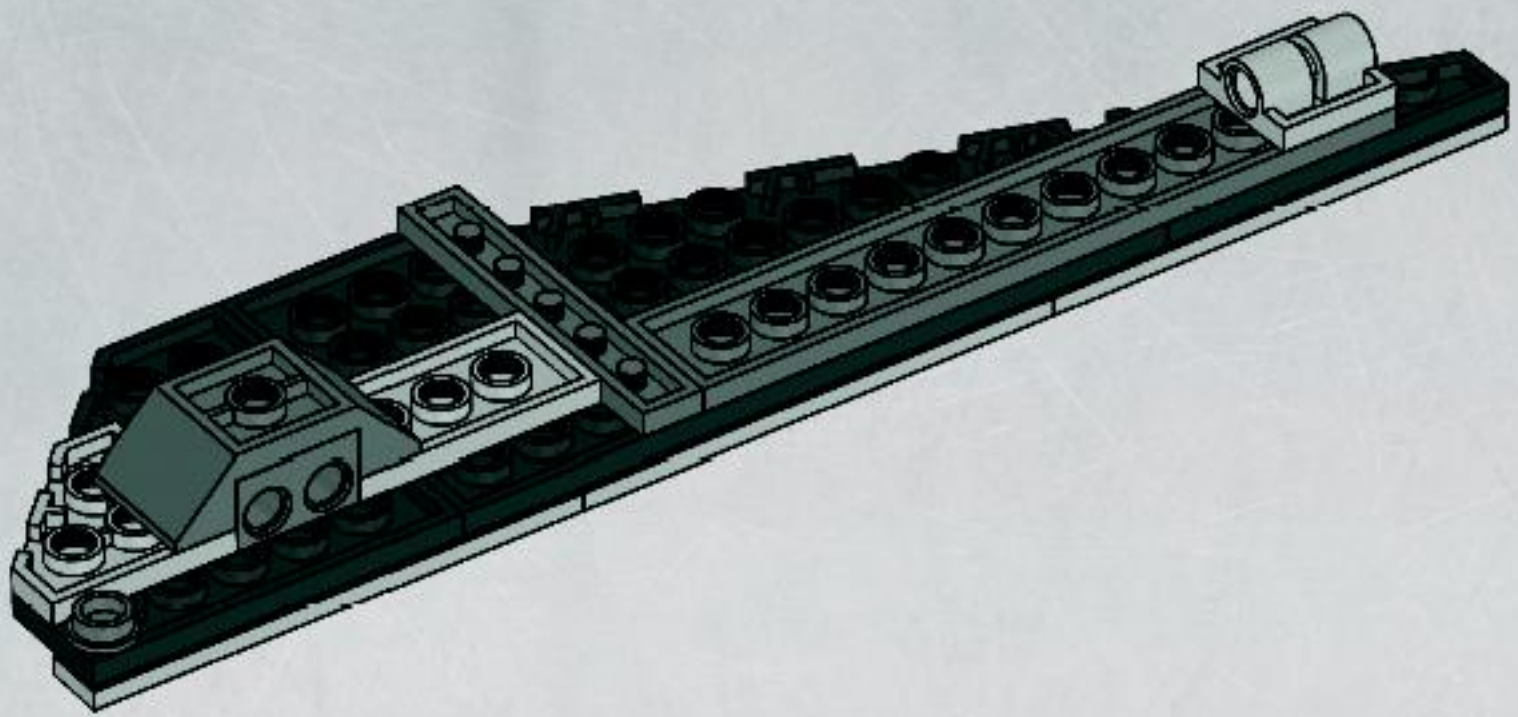



1x



1x

12

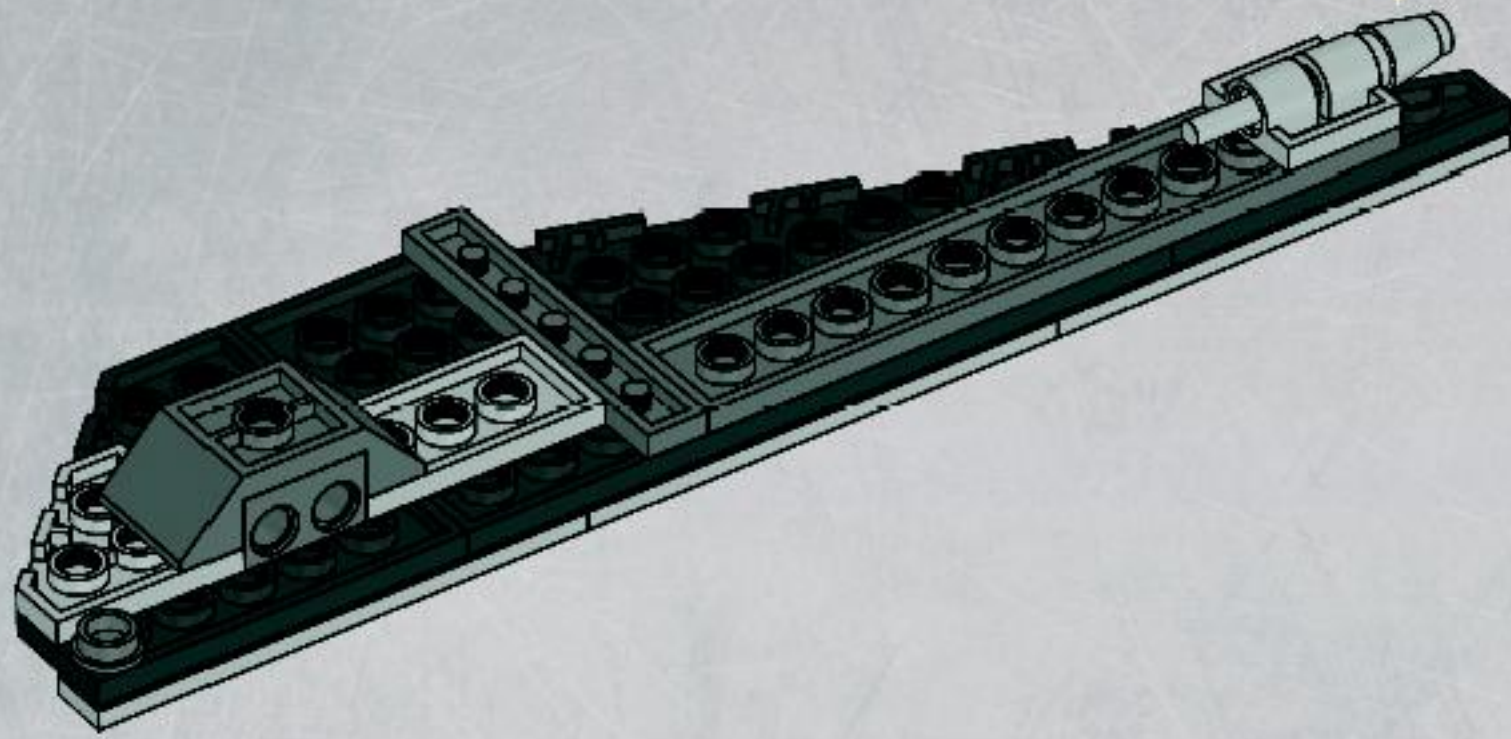

13

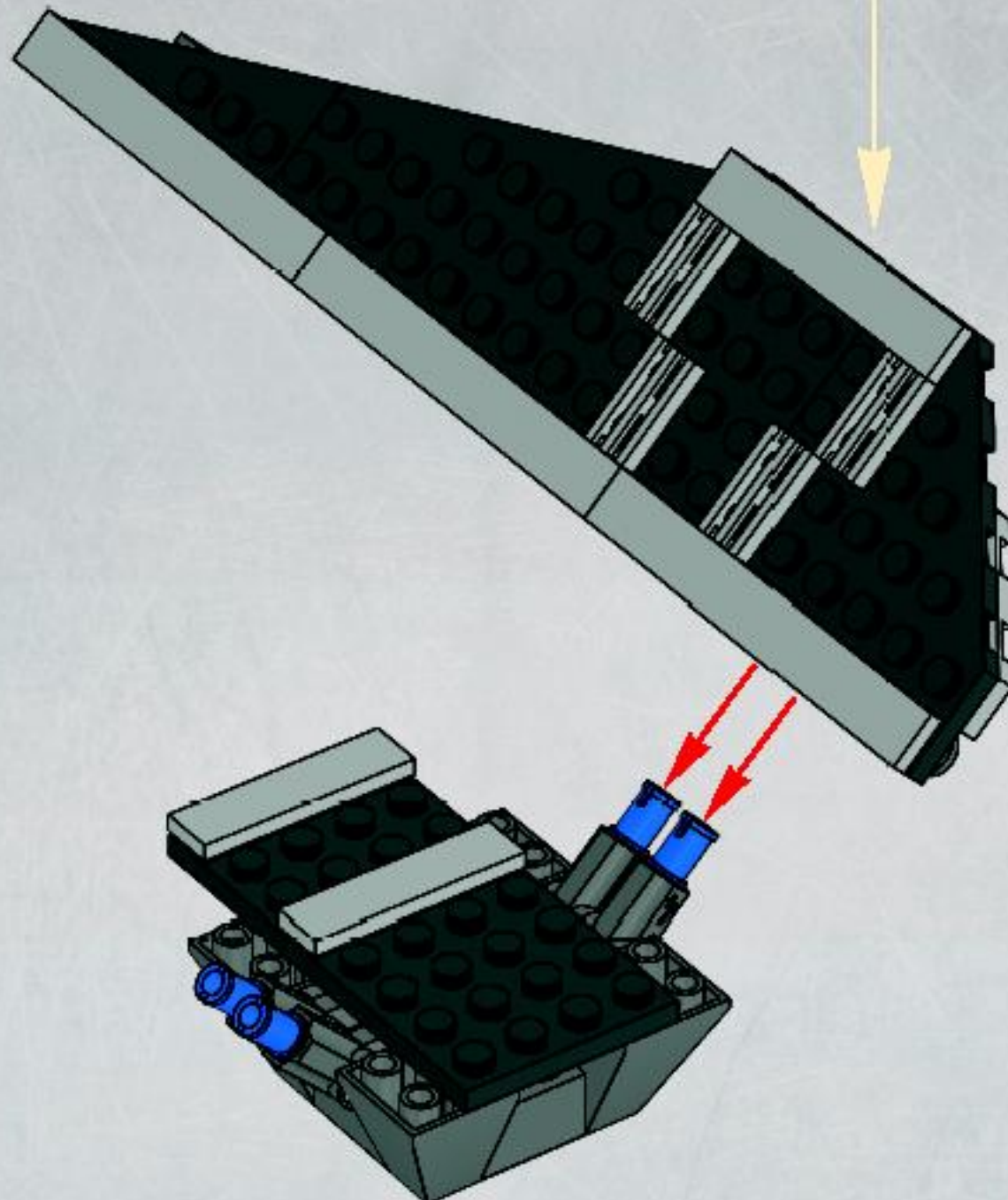

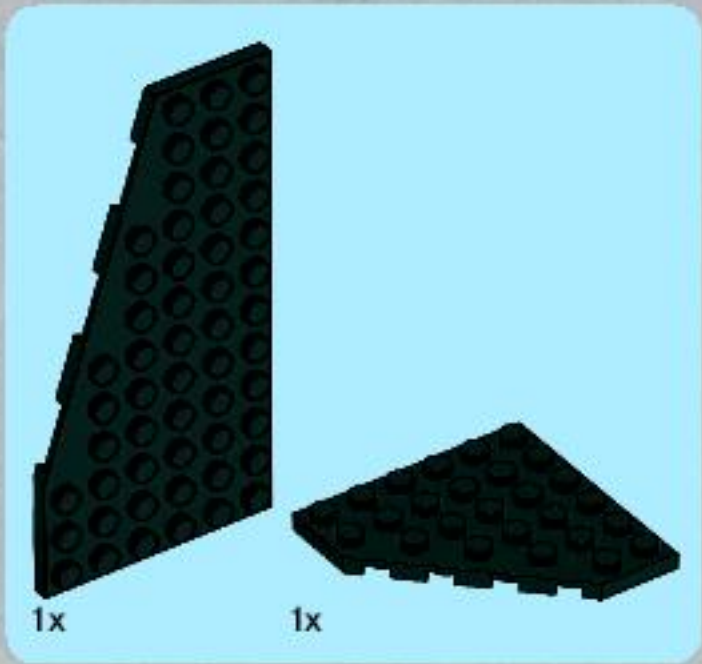

1

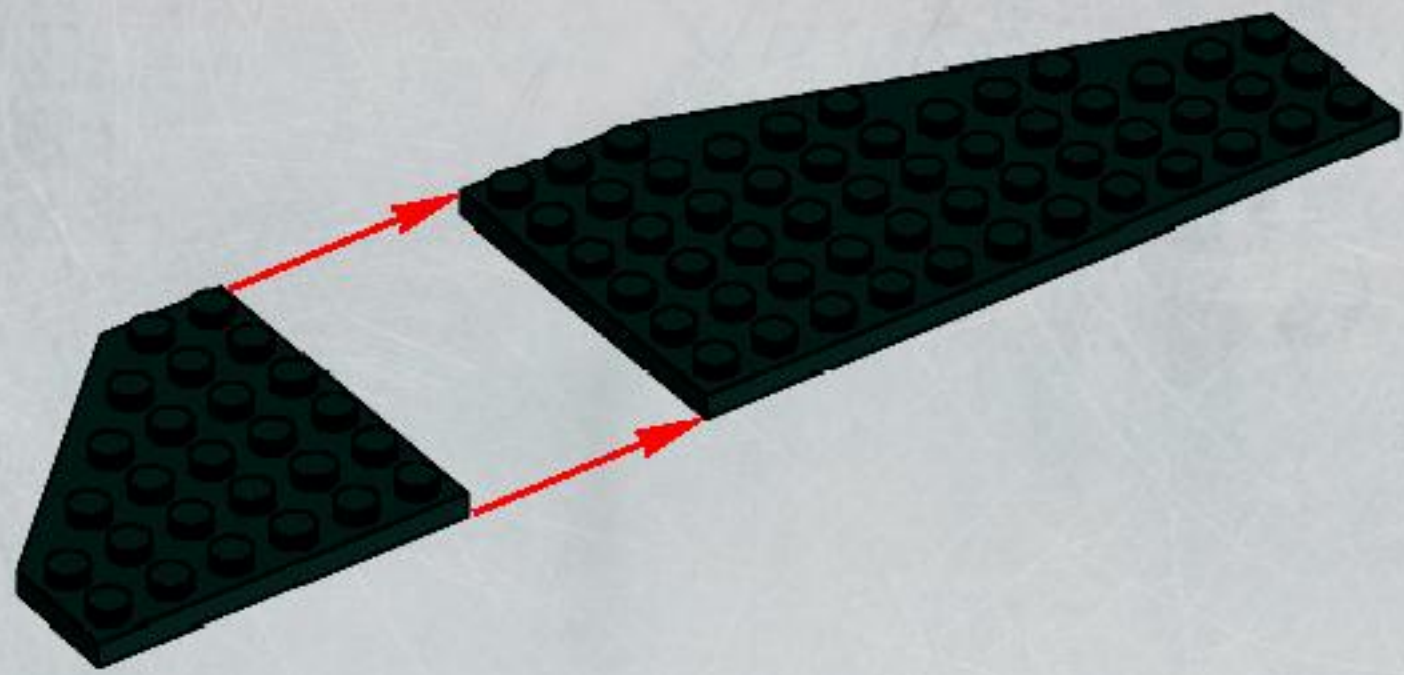

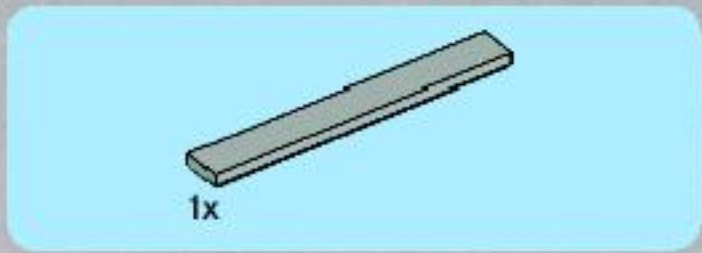

2

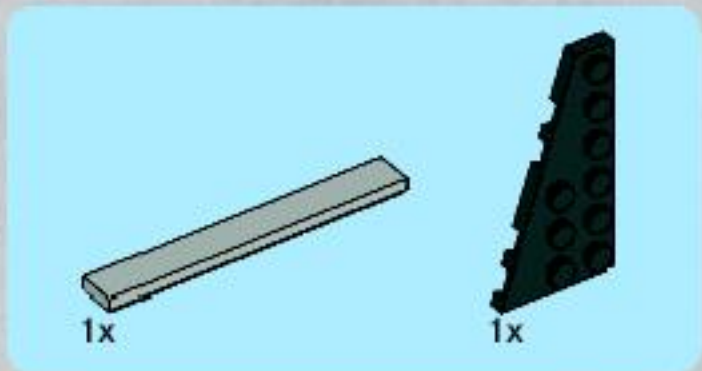
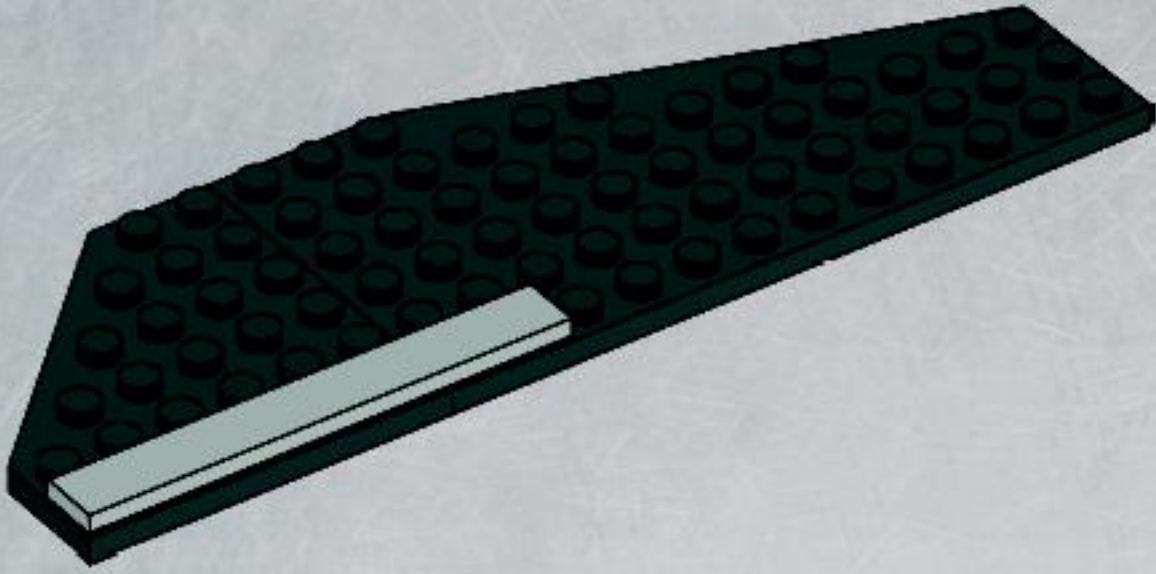

3

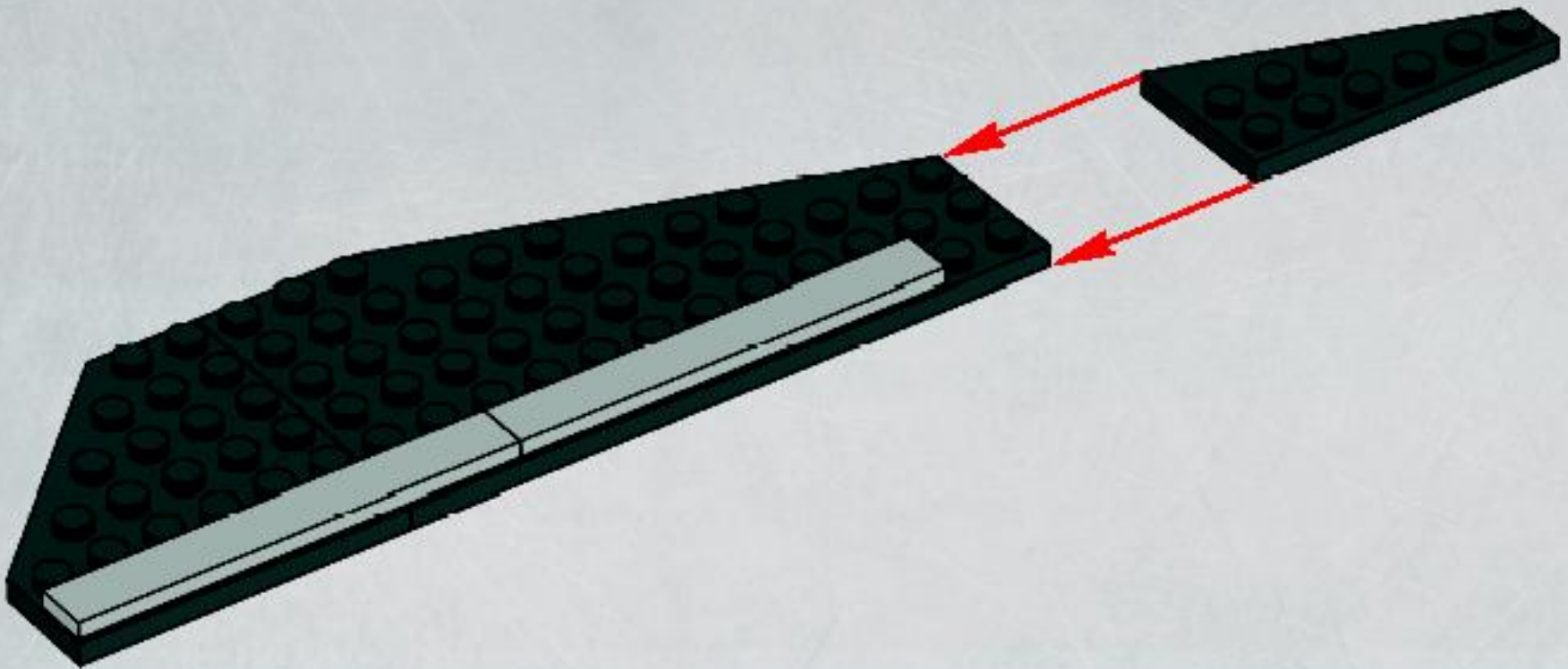

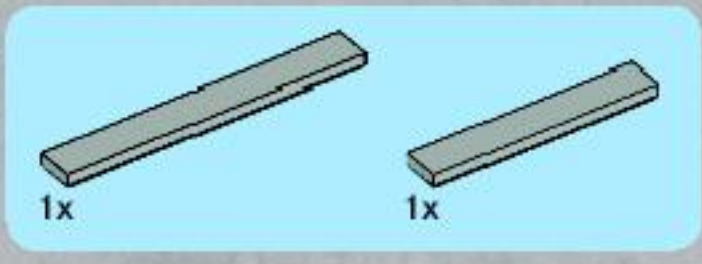

4

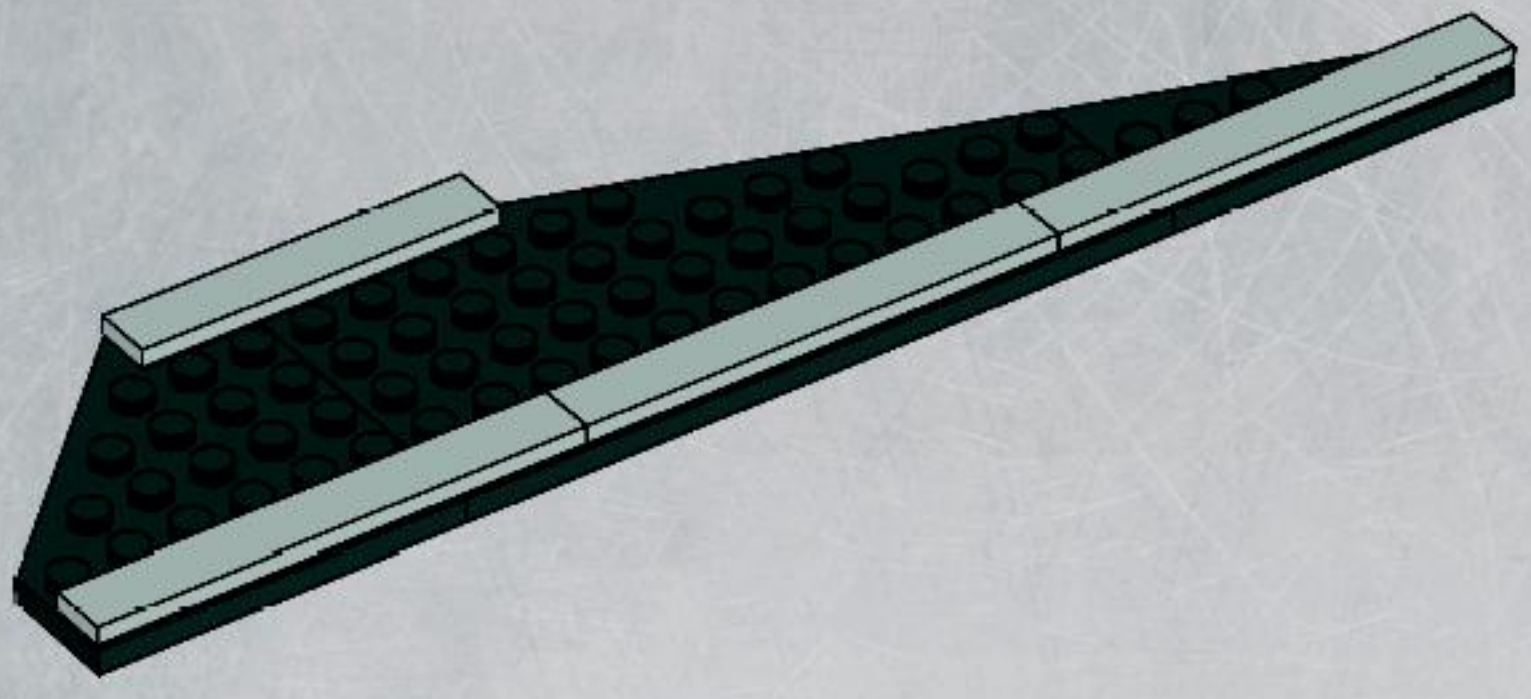

5

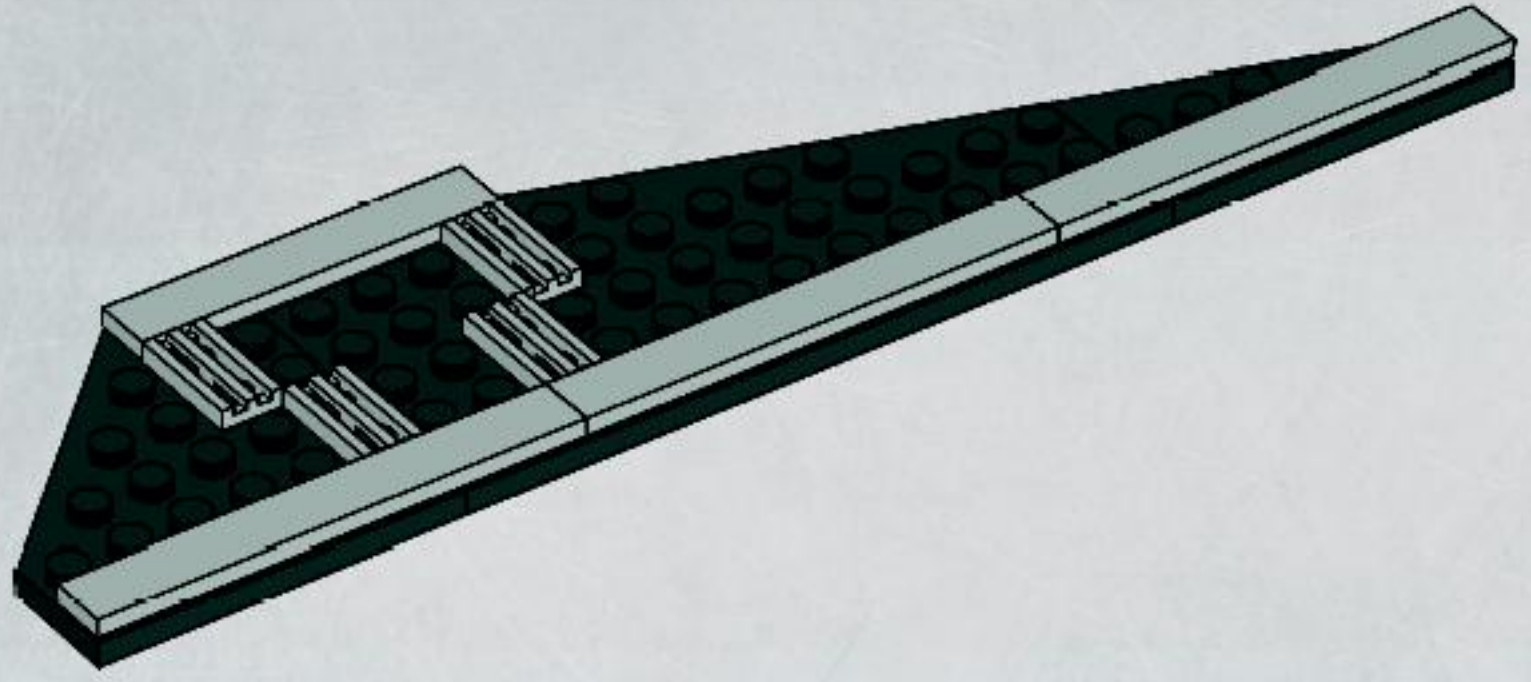



1x

6

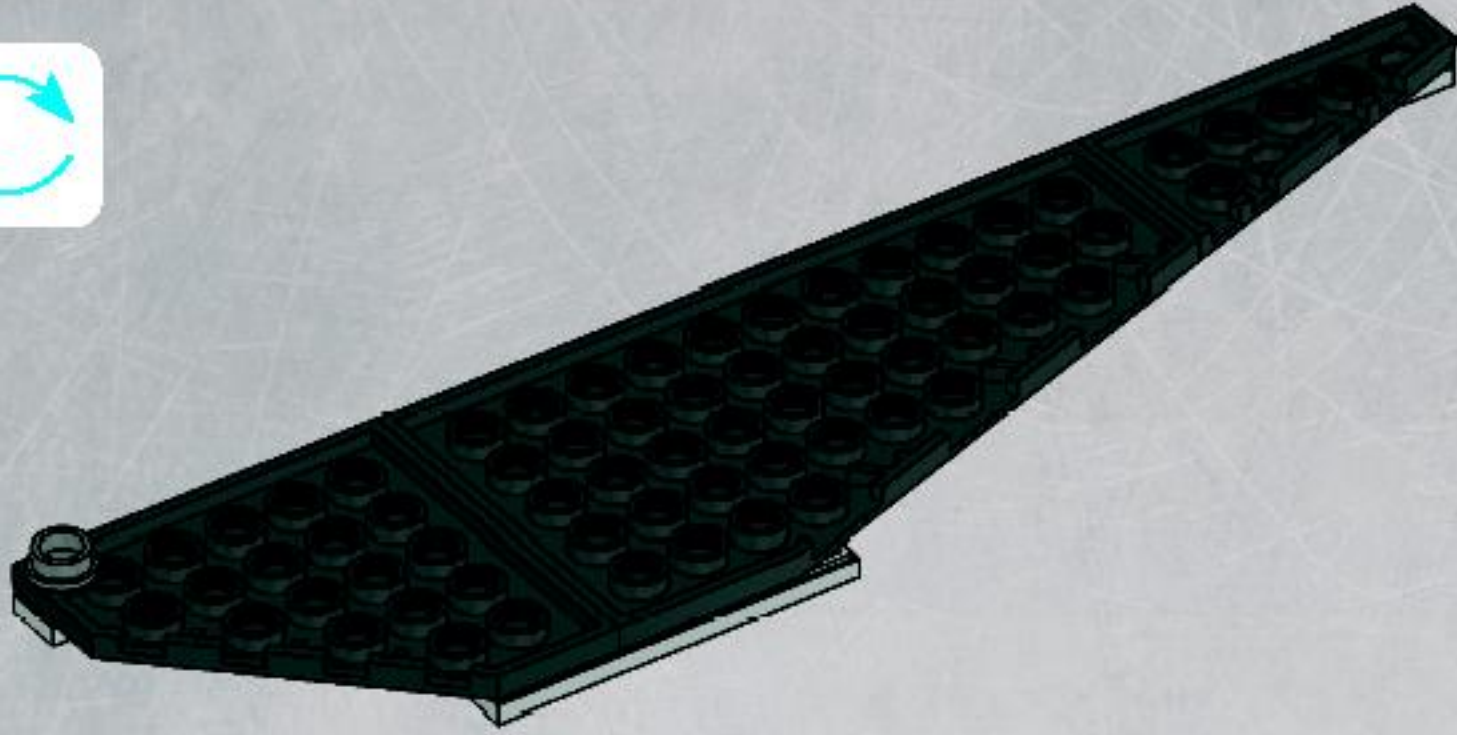

1x



1x

7

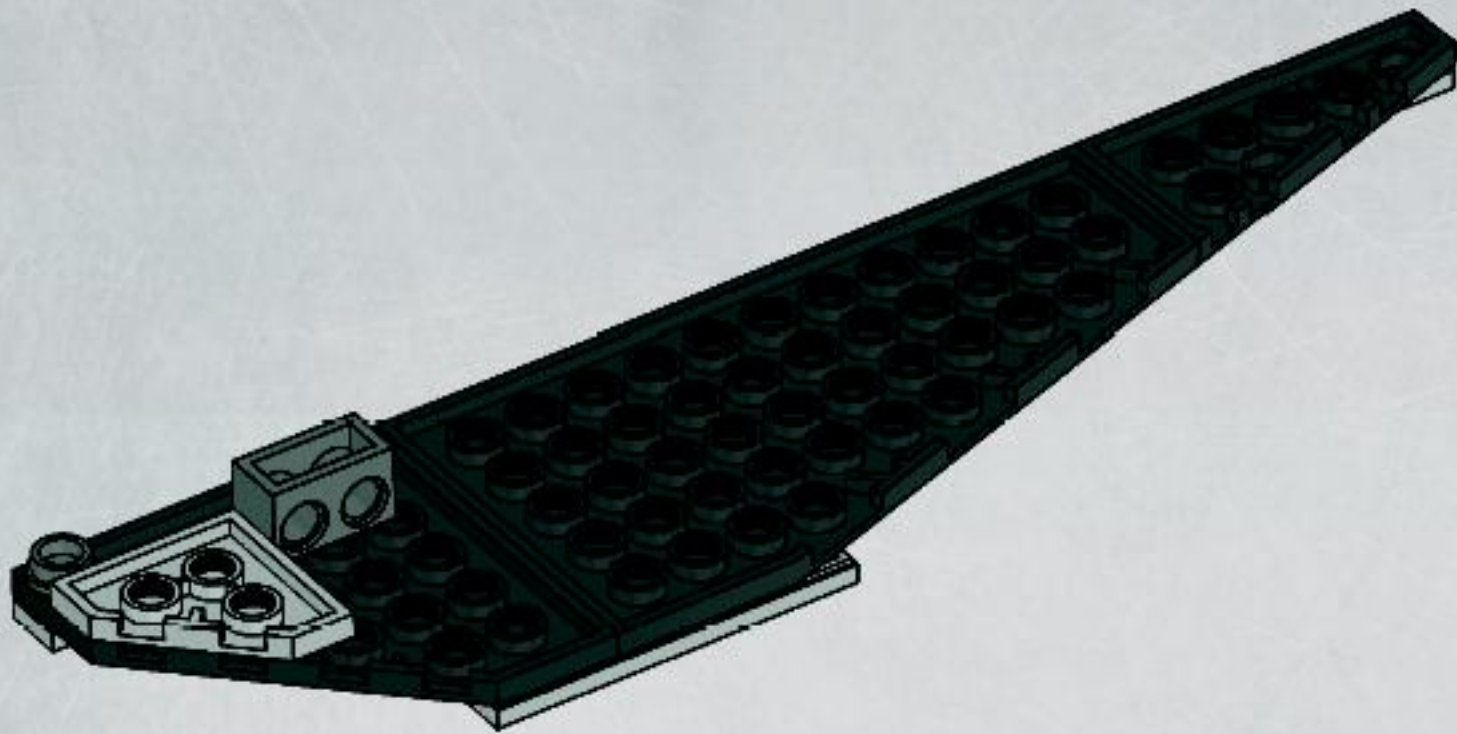



1x



1x

8

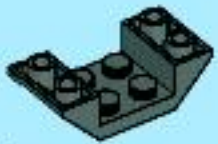
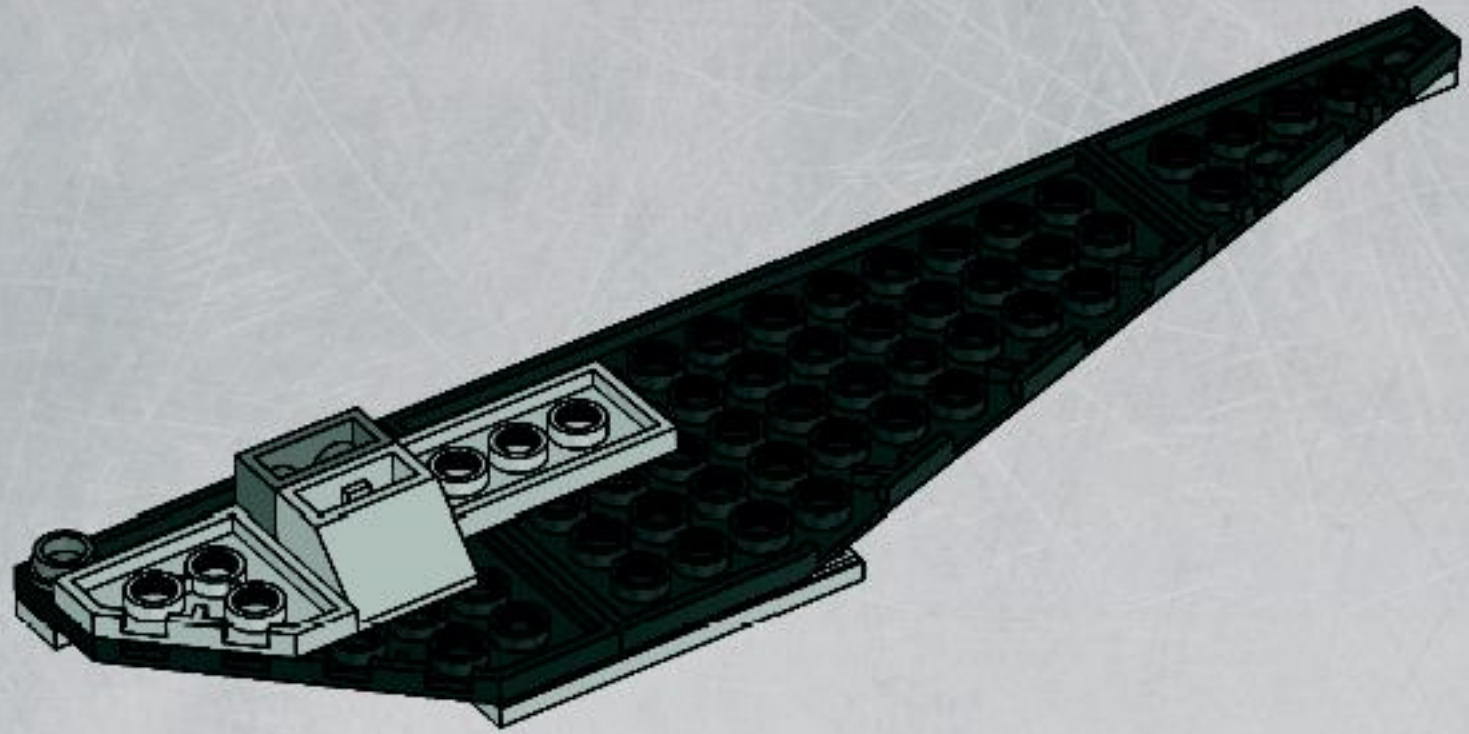

1x

9

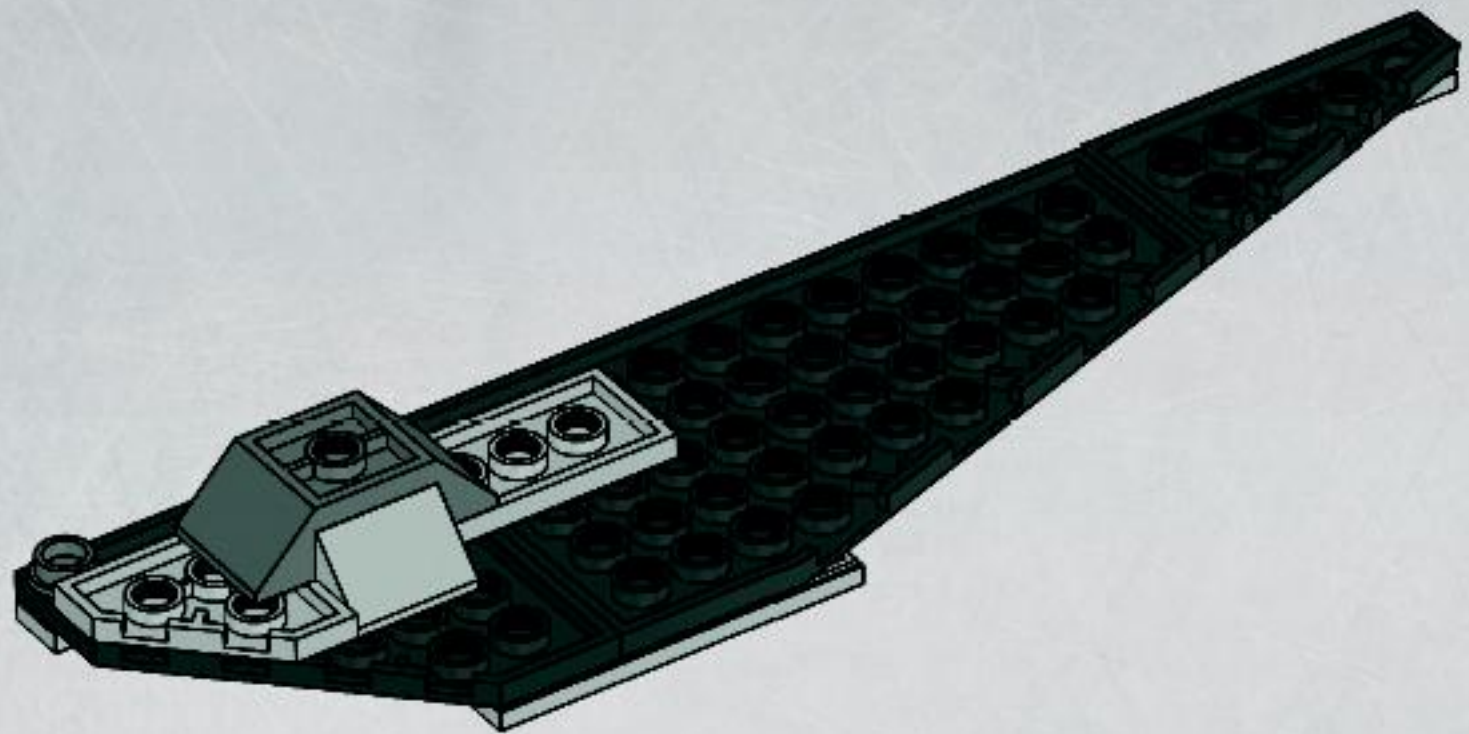

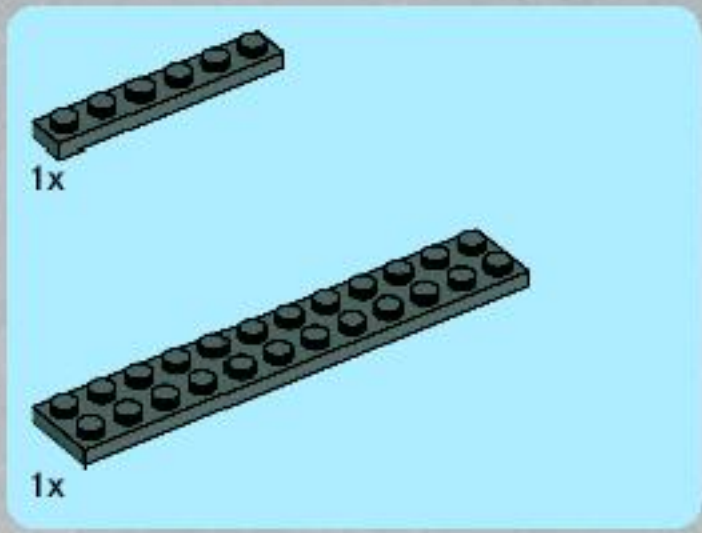

10

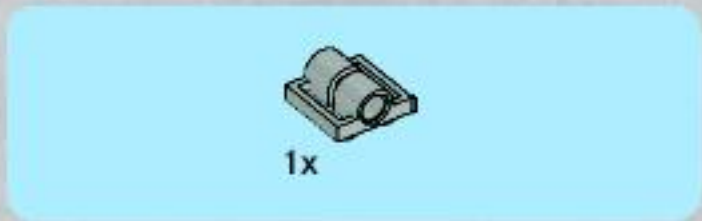
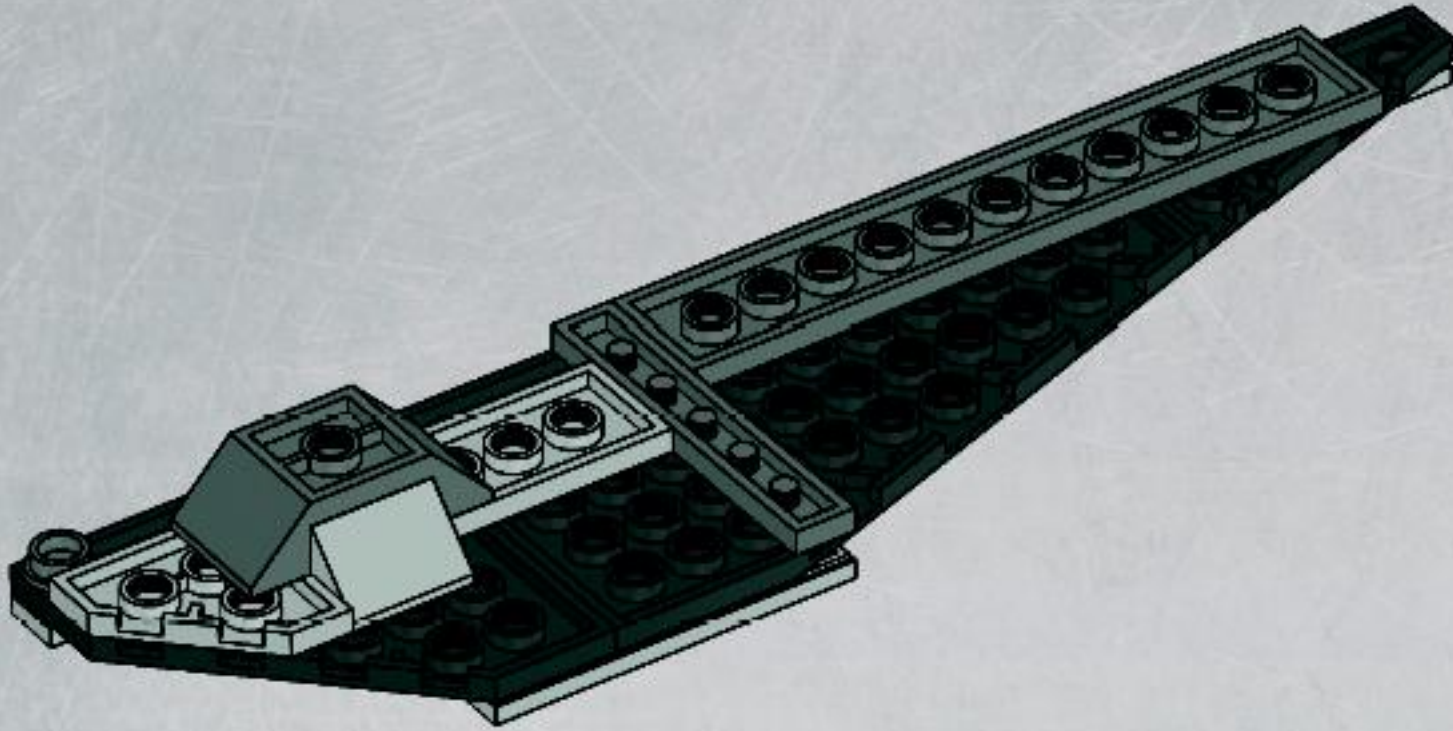

11

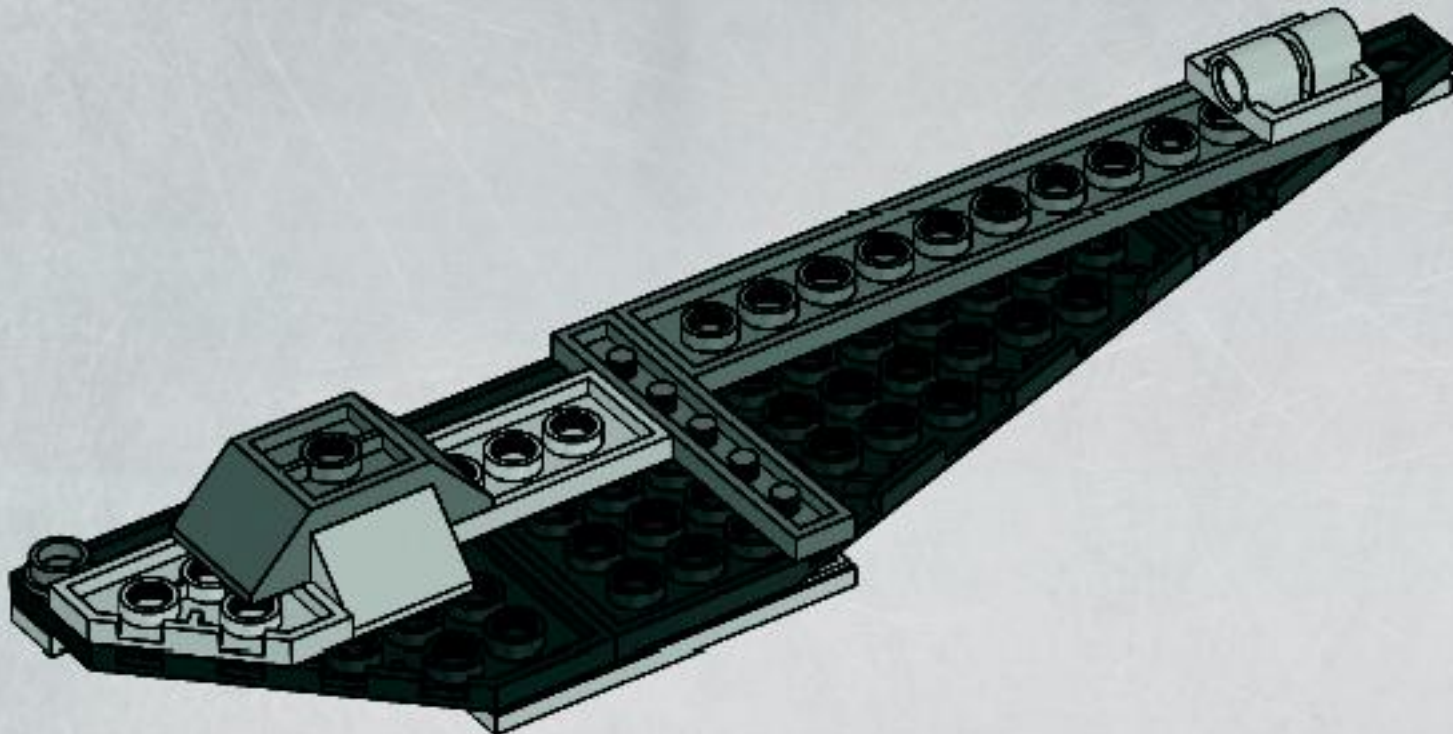



1x



1x



12

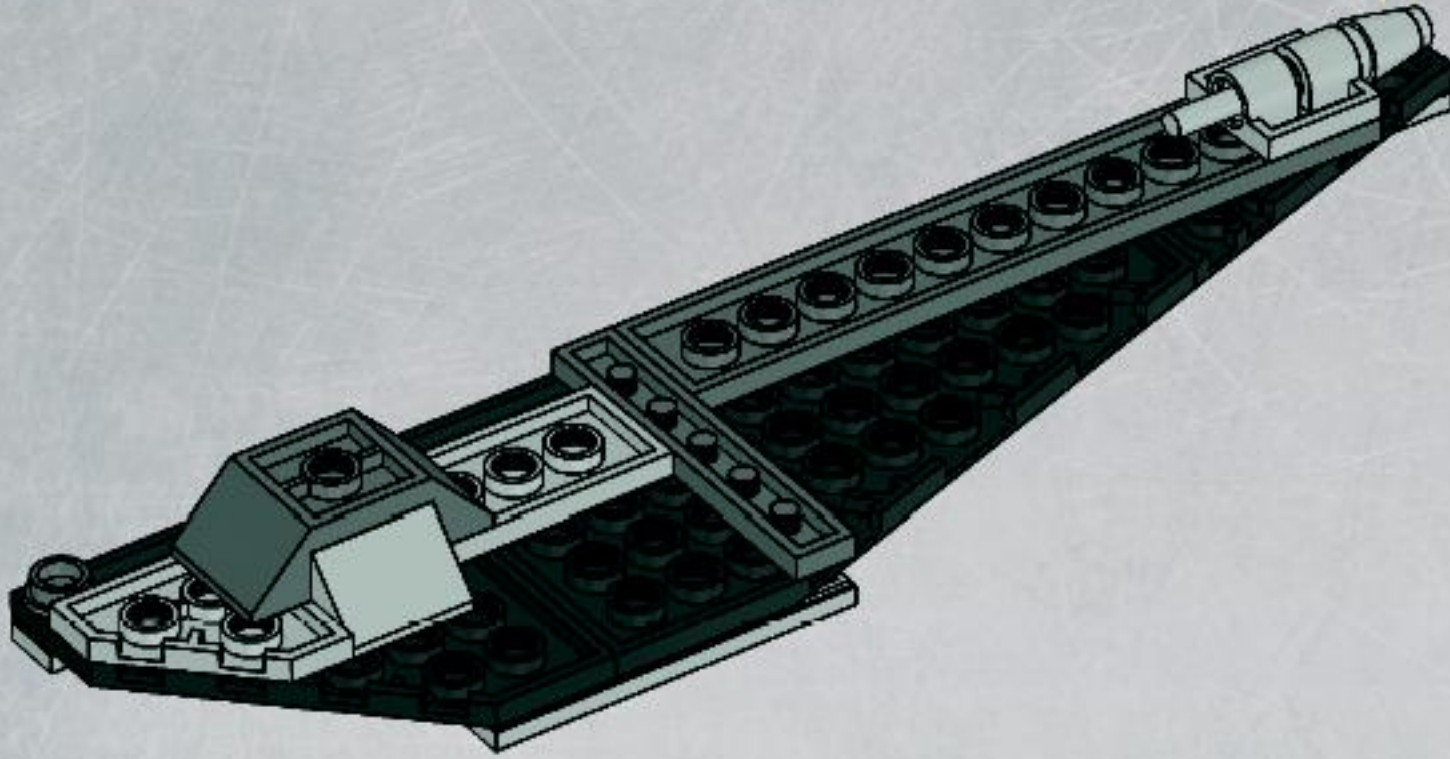

13

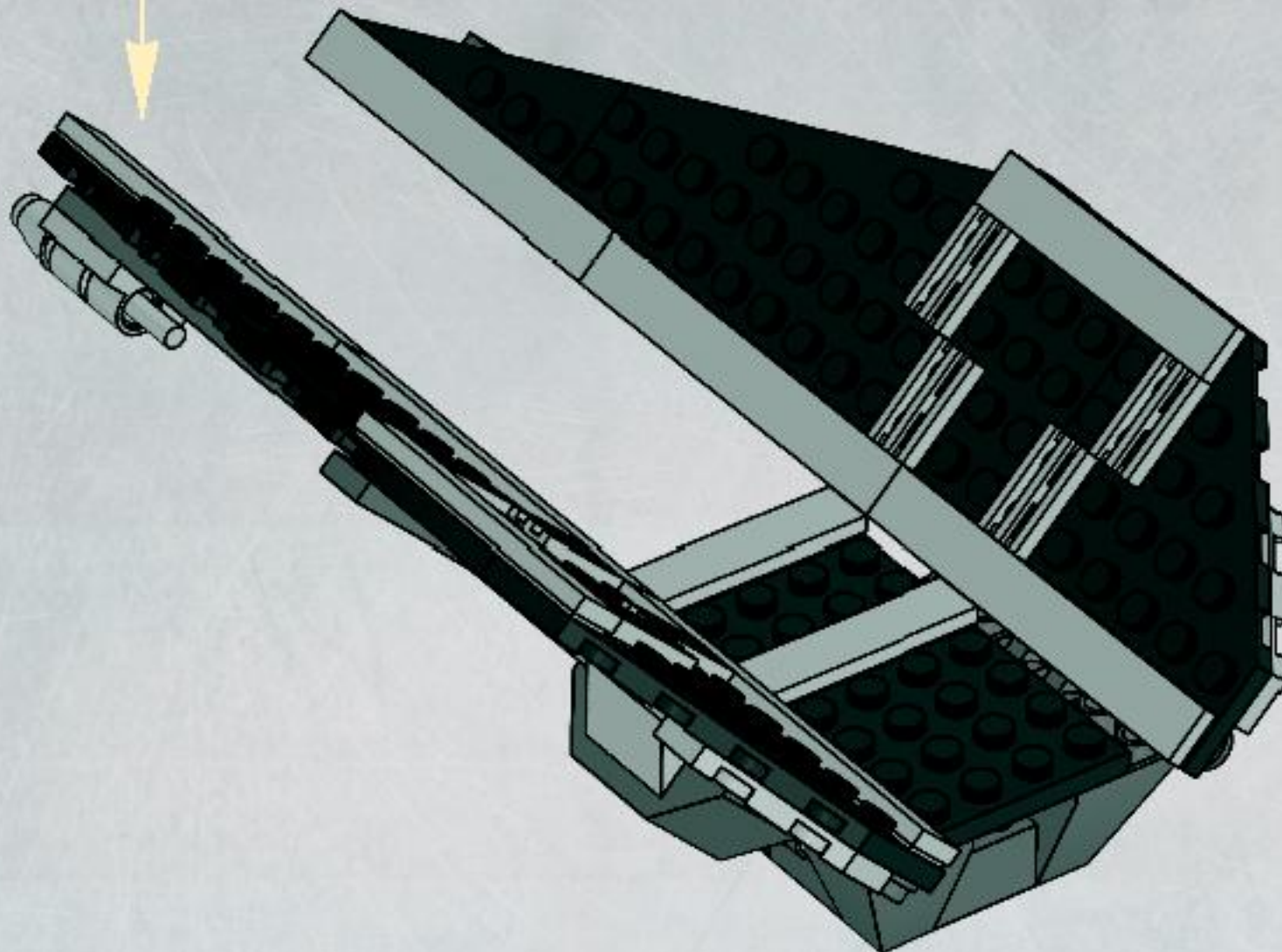

3x

14

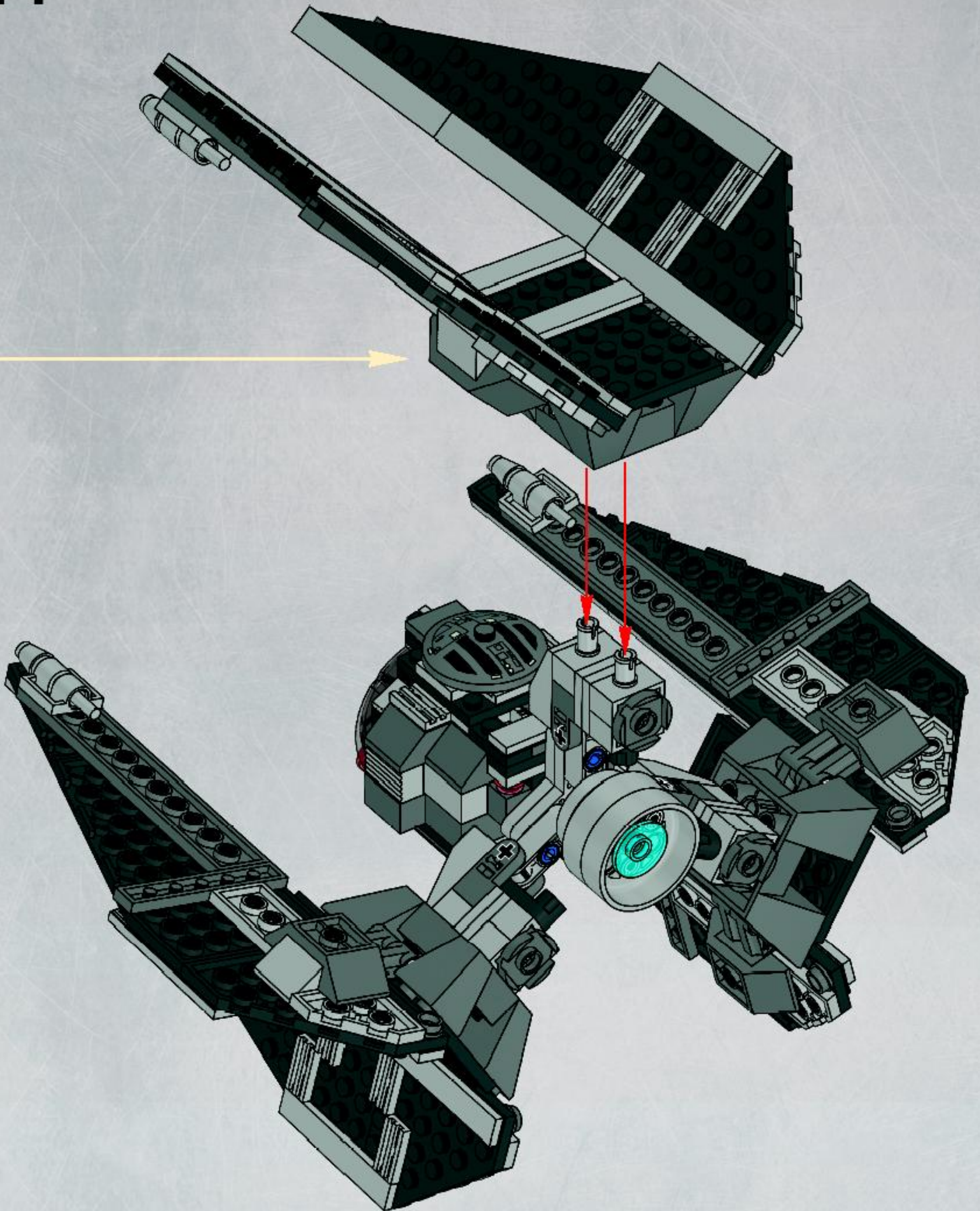

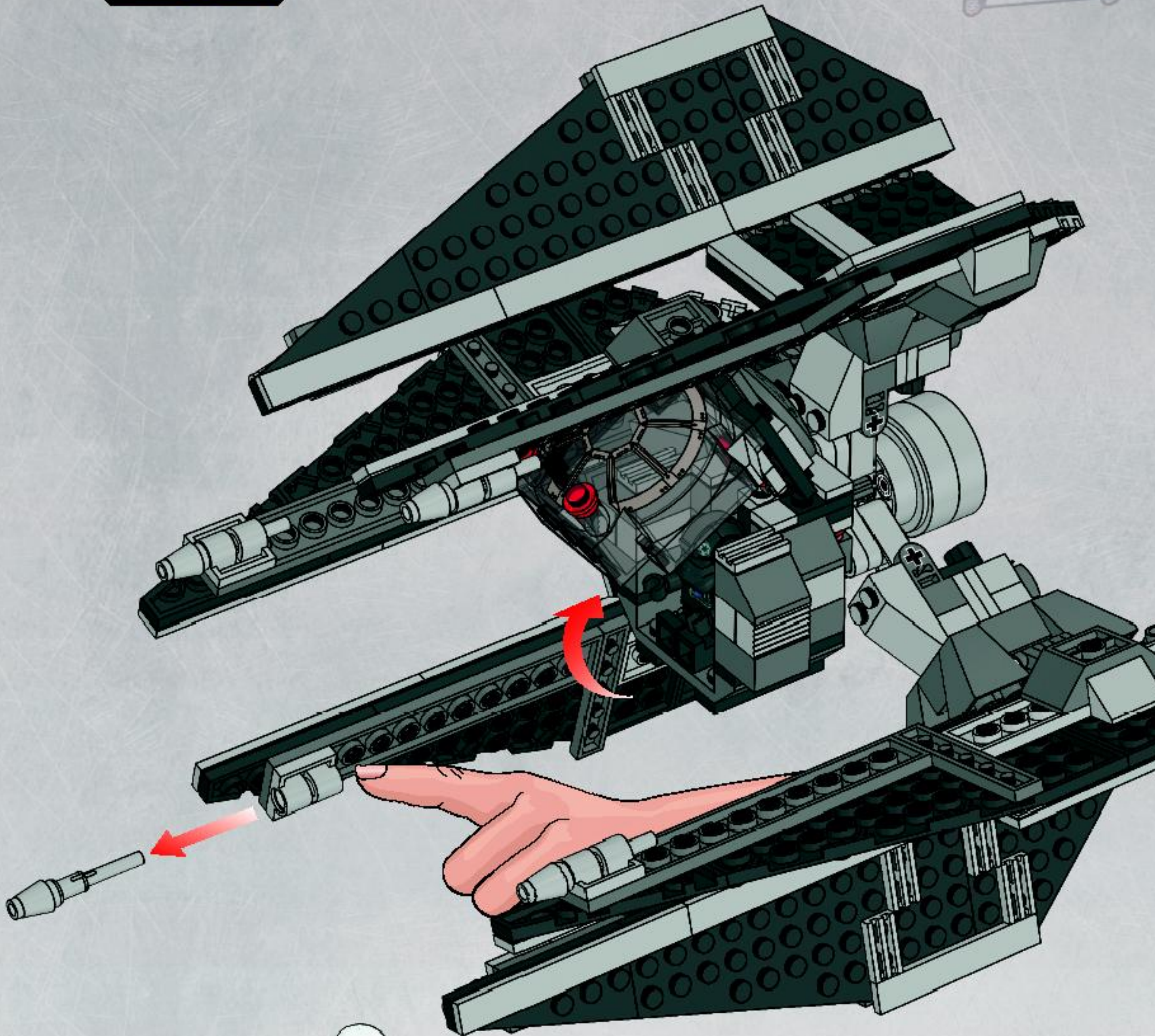



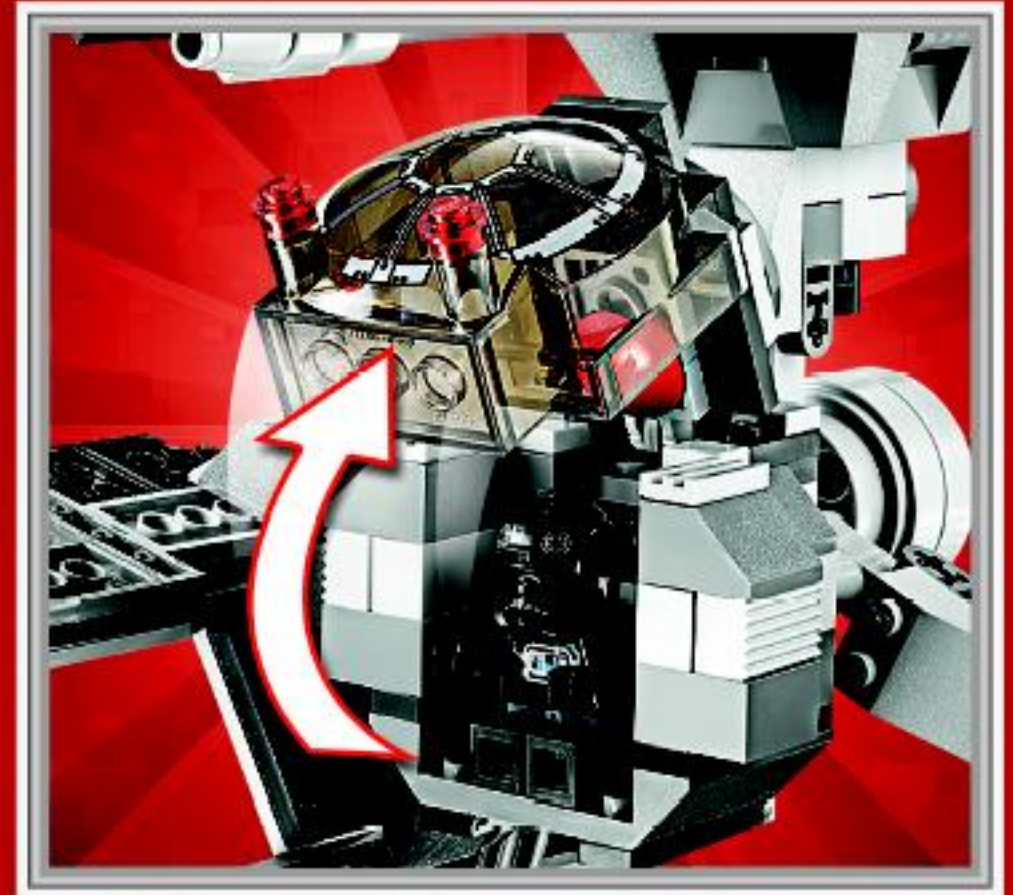
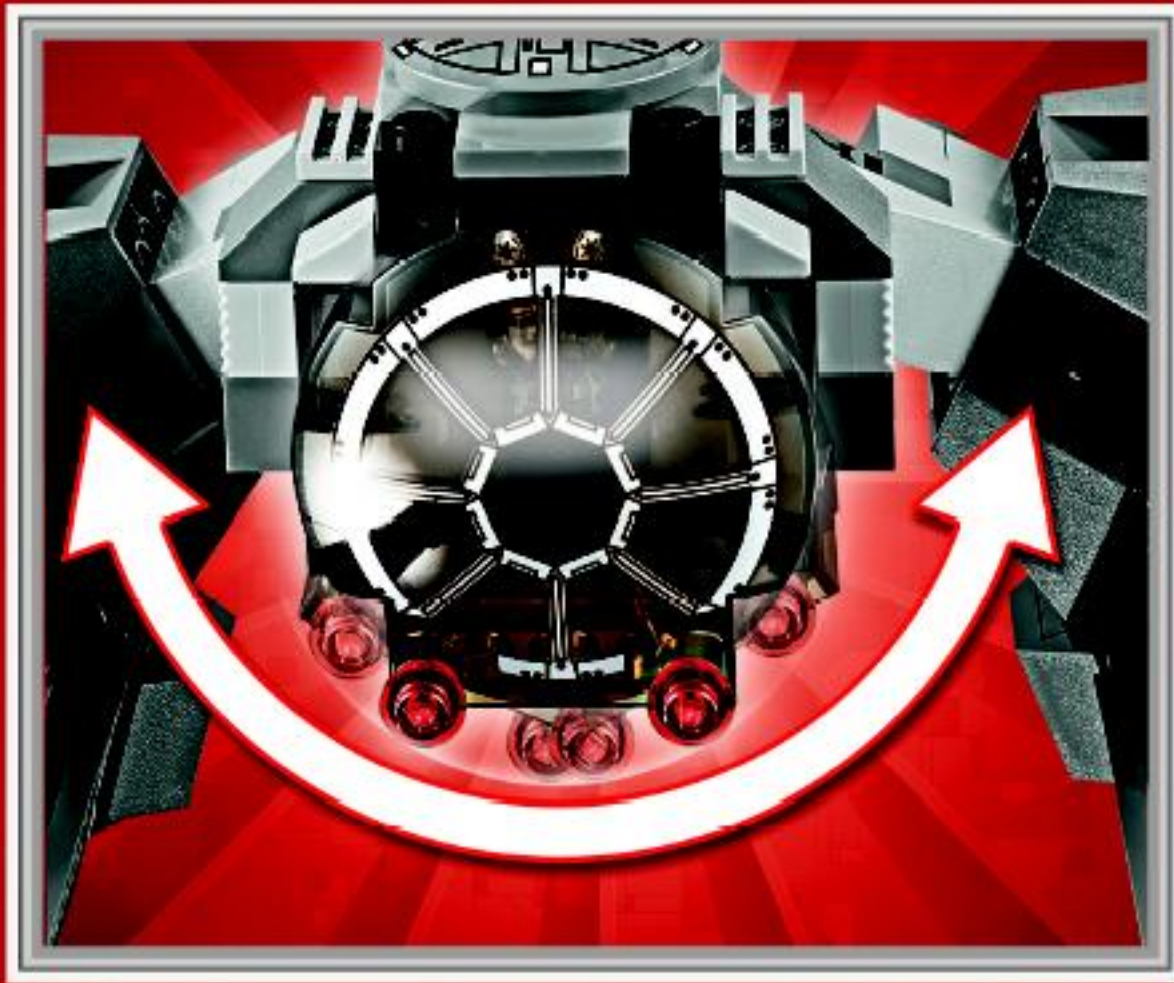

Customer Service
Kundenservice
Service Consommateurs
Servicio Al Consumidor
www.lego.com/service or dial
 00800 5346 5555 : 
 1-800-422-5346 : 

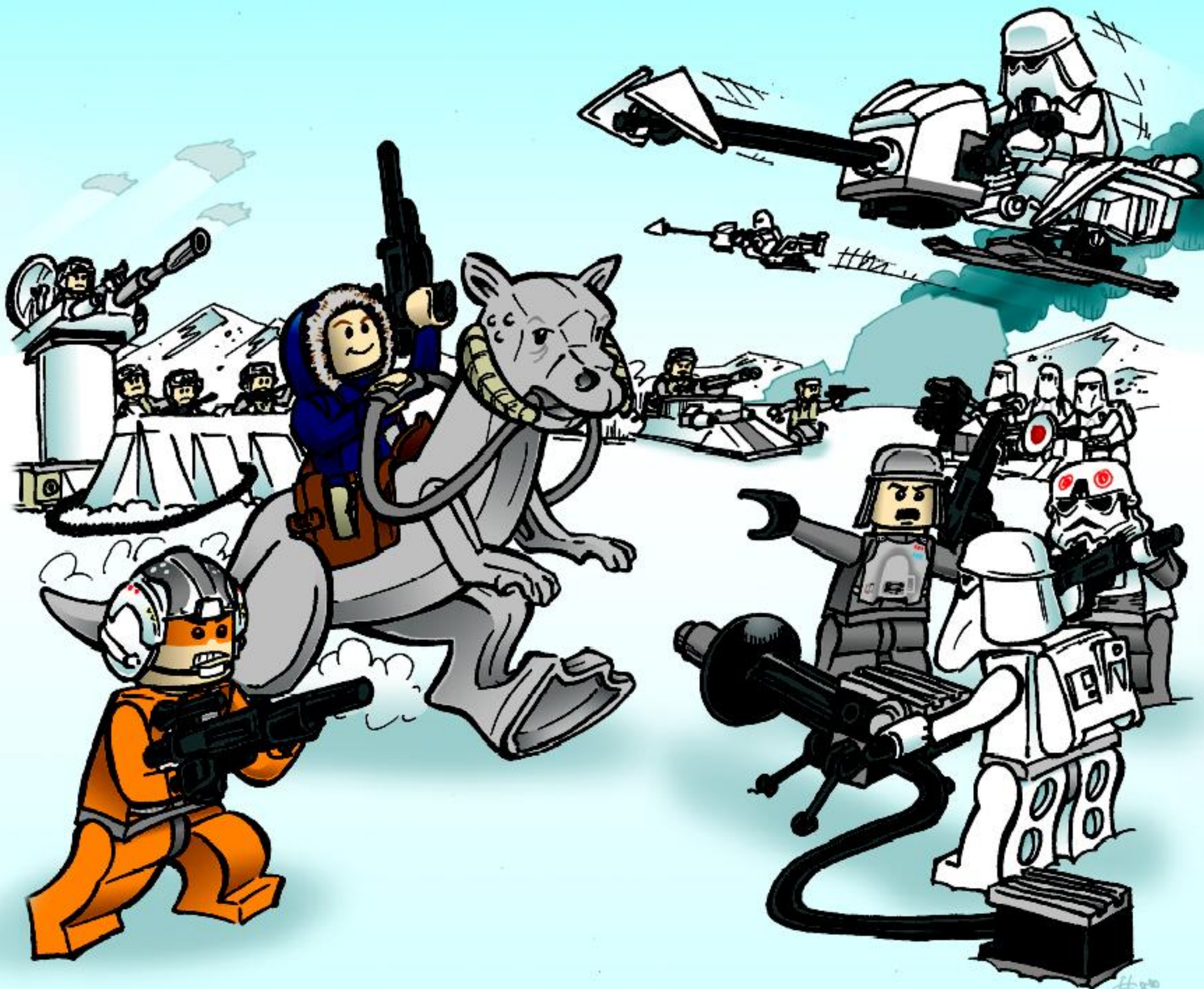



8083



8084



7749



8085



8086



8088



**STAR
WARS**





STAR WARS





8036



8037



8038



8039

FREE! GRATIS! GRATUIT!



club
MAGAZINE™

www.LEGOclub.com



00800 5346 5555*



1-866-534-6258 • 1-877-518-5346

US & Canada only

Canada seulement

* FreePhone. Mobile charges may apply. * Numéro sans Frais. Les Frais peuvent s'appliquer avec les téléphones cellulaires. * Gebührenfrei. Kosten für Anrufe aus Mobilfunknetzen können anfallen. * Gratis telefonnummer vóð vaxa líti. * Heleerelt gratis nummer, når du ringer fra Postboks. * De Cost gratis, når du ringer från en Postboks. * Gratís telefonnúmer vaxa líti.



VISIT THE WORLD'S
BIGGEST LEGO® SHOP!

www.LEGOshop.com



WIN!

Go to www.nielsen.com/LEGO to fill out a survey for a chance to win a cool LEGO® Product. No purchase necessary. Open to all residents where not prohibited.



www.nielsen.com/LEGO

GEWINNE!

Nimm an der Umfrage auf www.nielsen.com/LEGO teil und hab die Chance ein cooles LEGO® Produkt zu gewinnen!
Die Teilnahme am Gewinnspiel führt zu keinerlei Kaufverpflichtungen. Teilnahme in allen nicht ausgeschlossenen Ländern möglich.

WIN!

Ga naar www.nielsen.com/LEGO, vul een enquêteformulier in en maak kans op een cool LEGO® product.
Geen aankoopverplichting. Iedereen mag deelnemen, uitgezonderd ingezetenden van landen waar een enquêteverbod geldt.

GAGNE!

Visite www.nielsen.com/LEGO pour répondre à un questionnaire et avoir une chance de gagner un produit LEGO® très cool!
Aucune obligation d'achat. Ouvert à tous les résidents des pays autorisés.

当てよう!

www.nielsen.com/LEGOにアクセスして、アンケートにご記入ください。当選者にはレゴ製品を差し上げます。
お買い上げの必要はありません。禁止されていない限り、すべての年齢にご利用いただけます。