



# TECHNIC

8041





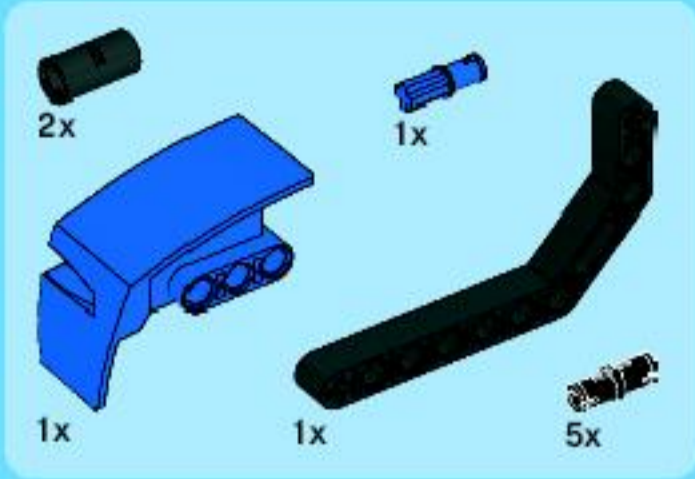

1



2



3



4



5



49

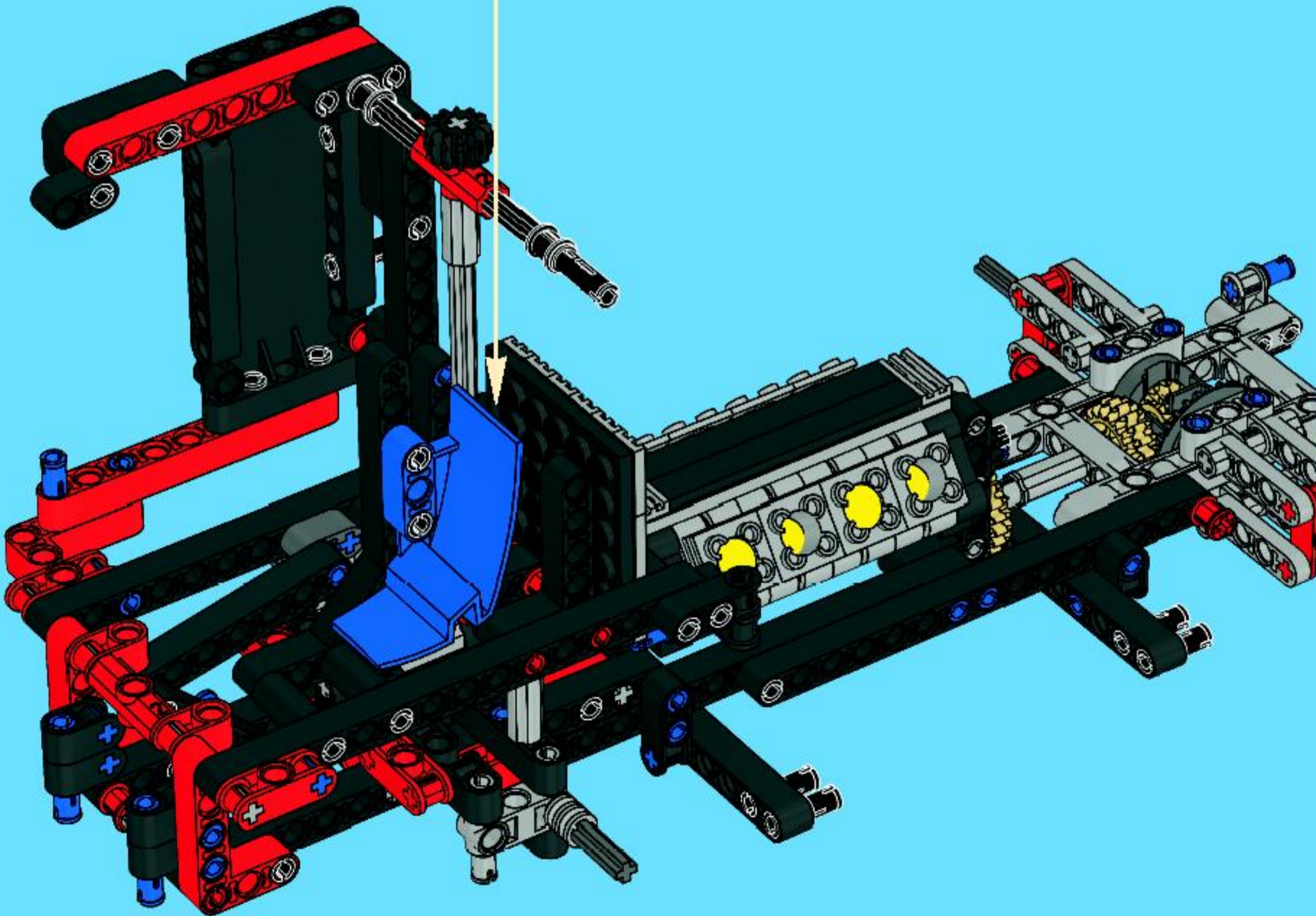



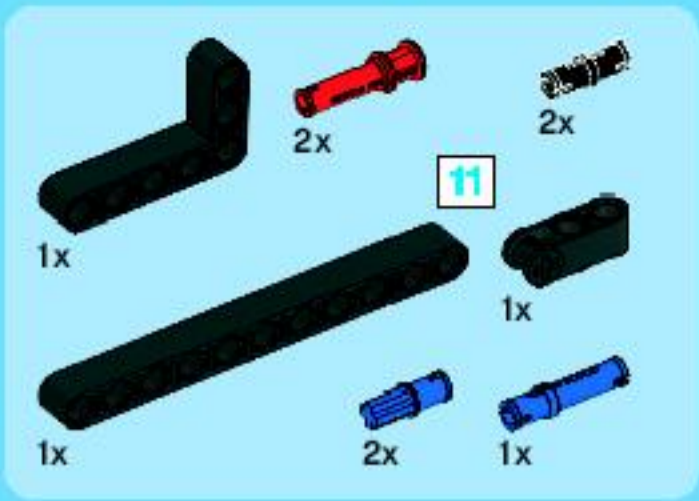

# 50

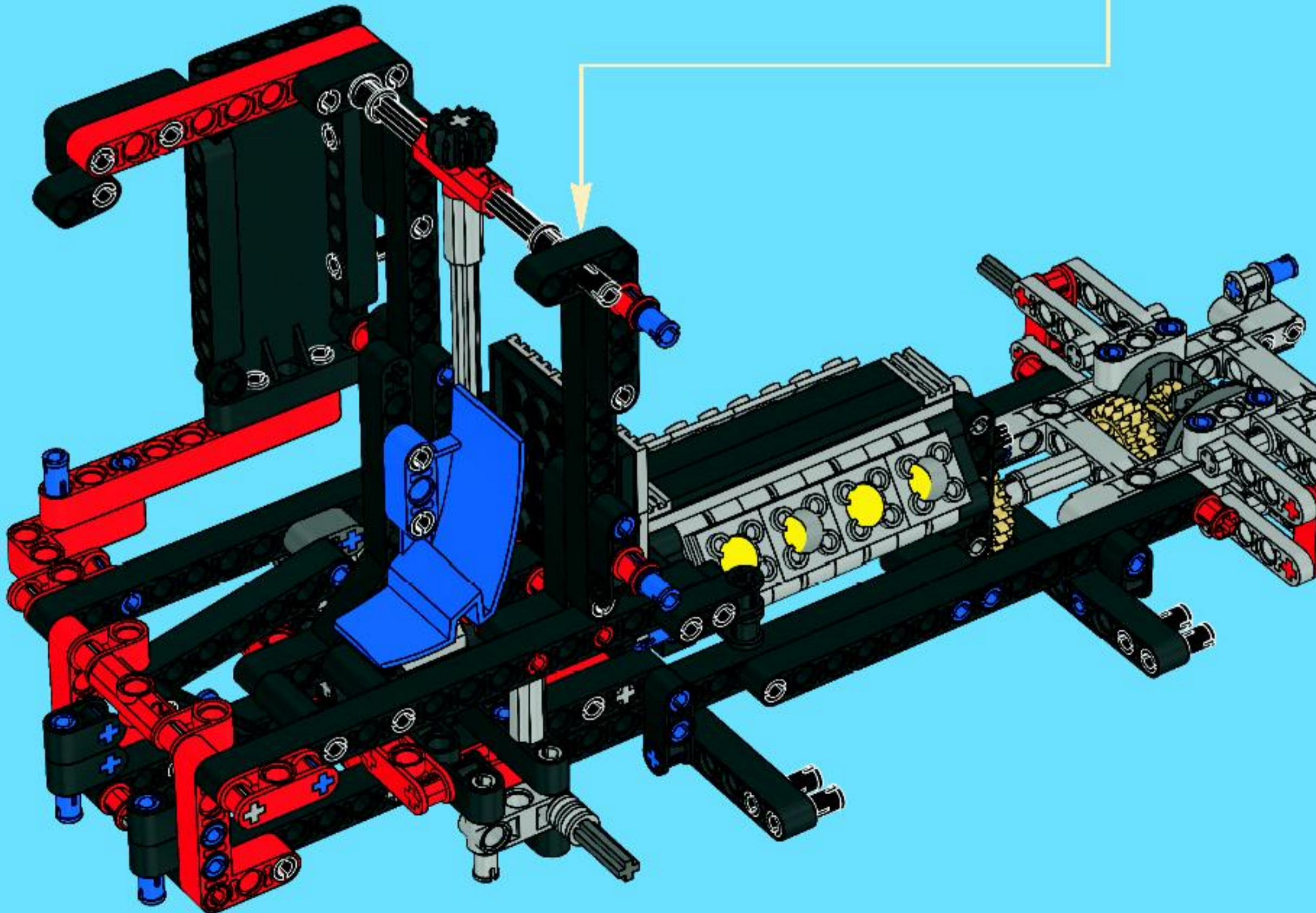
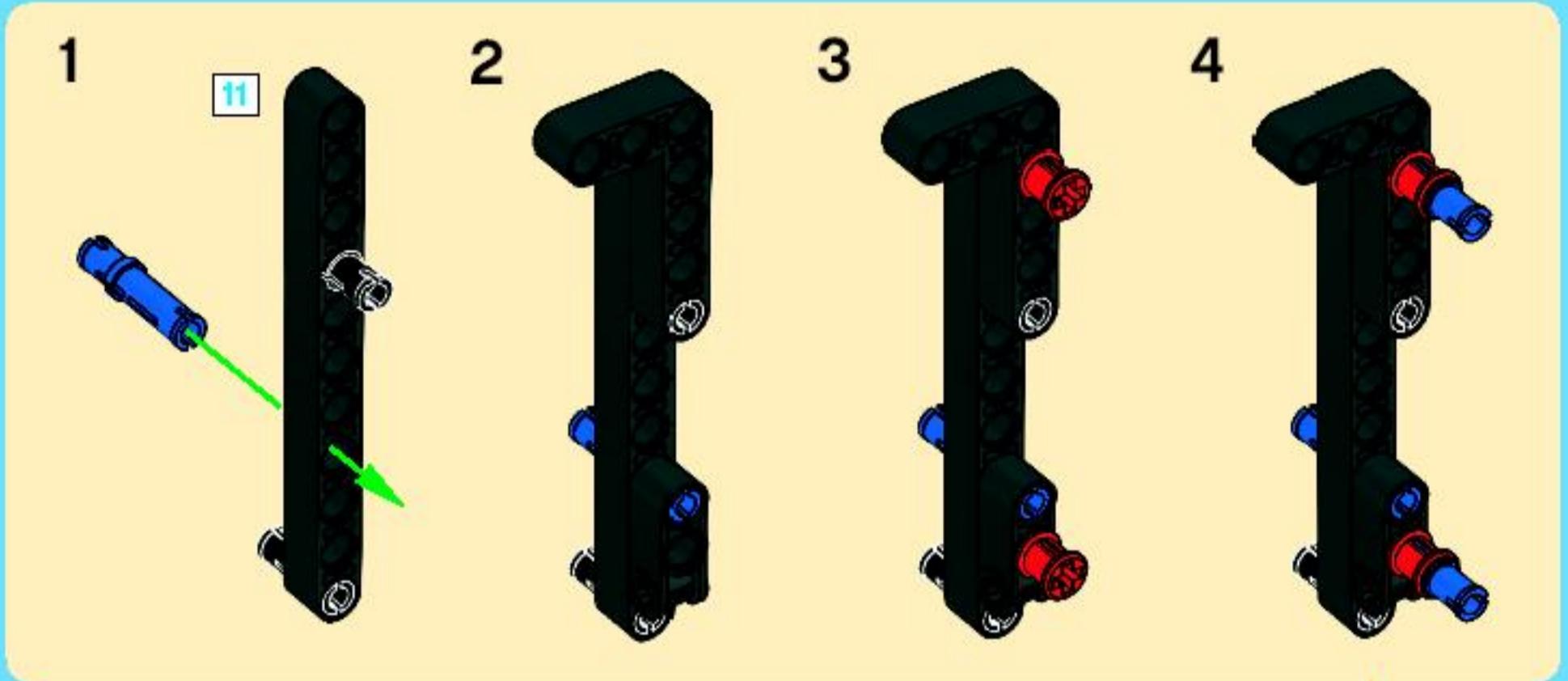





1

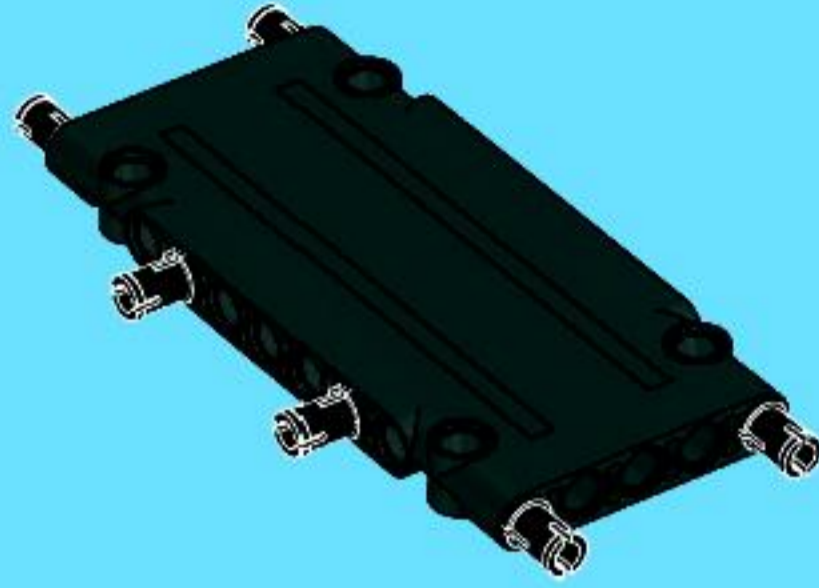

2



3





51

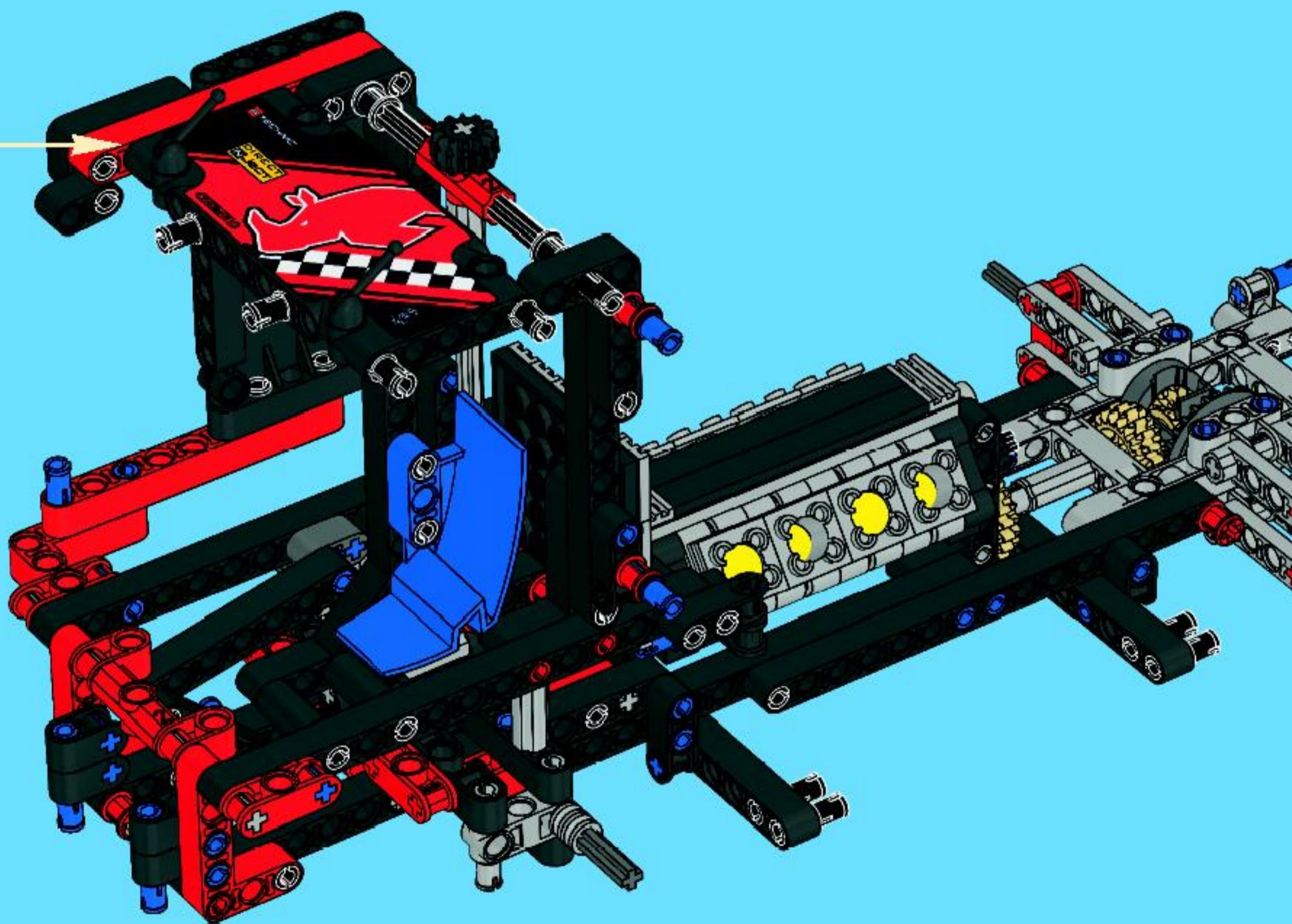



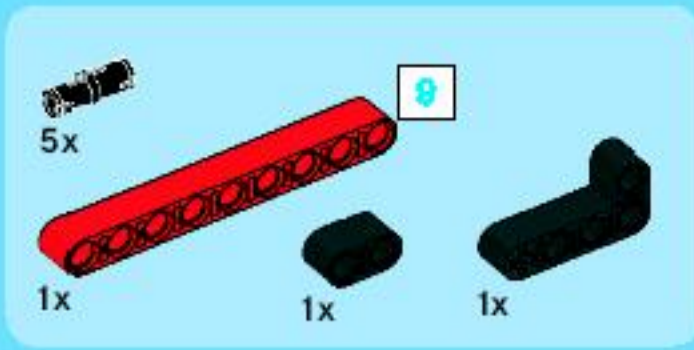

52

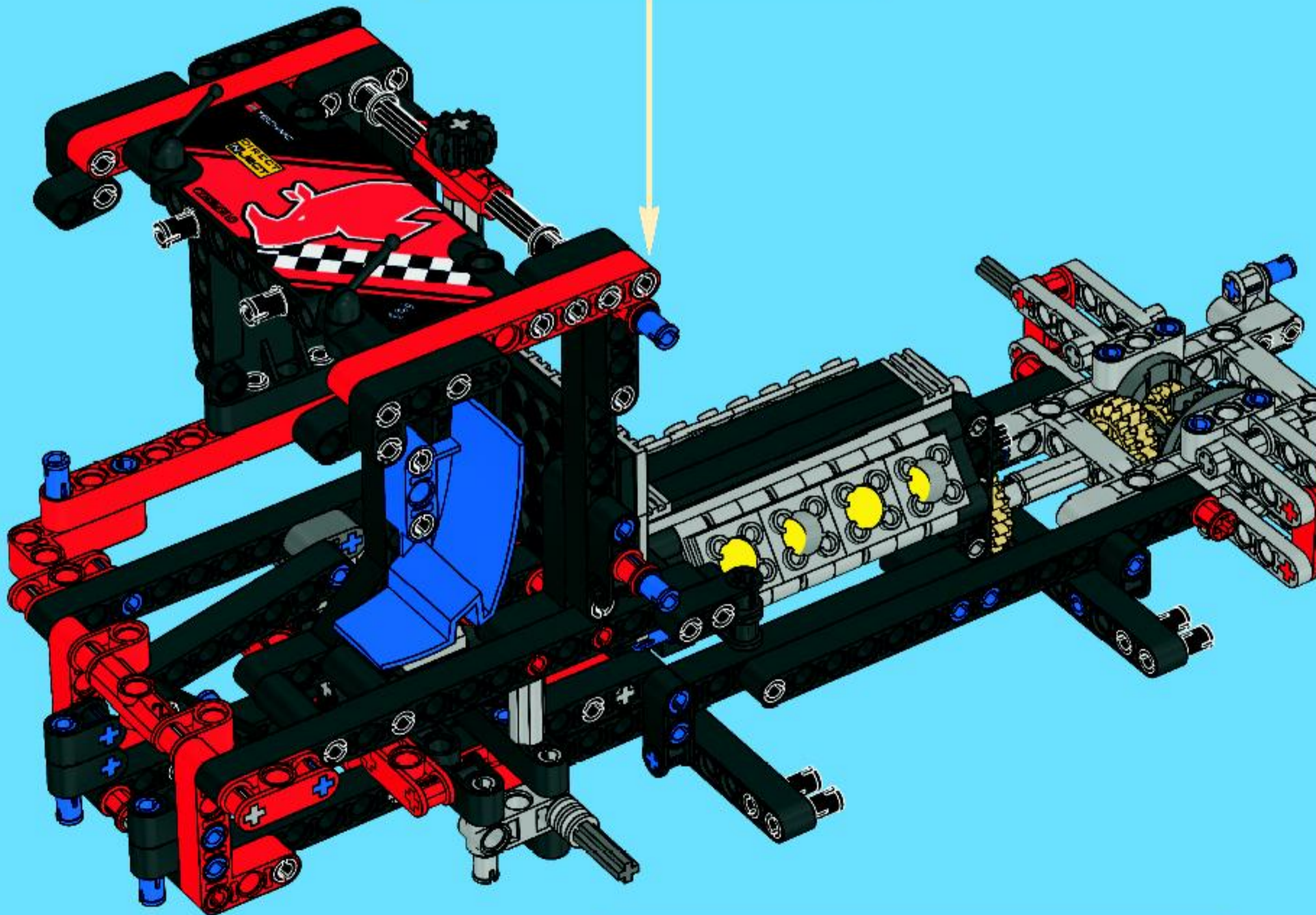
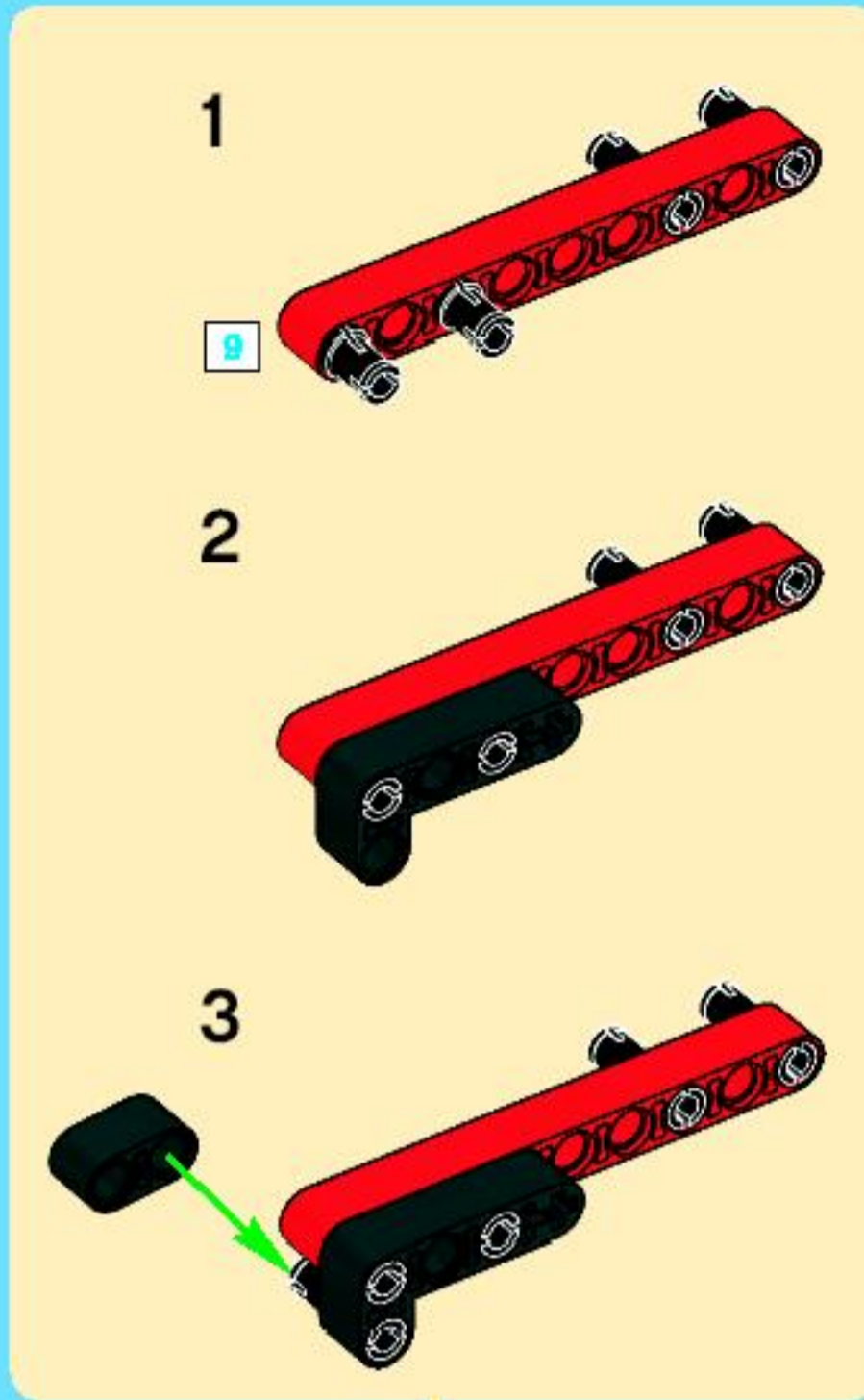



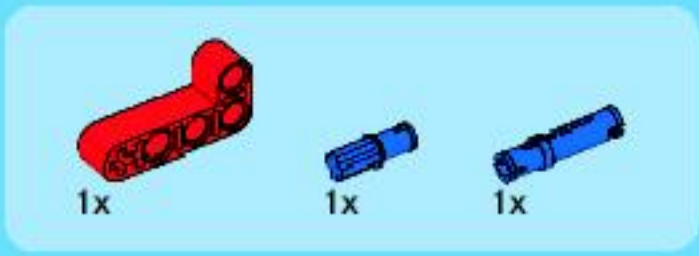

1



4

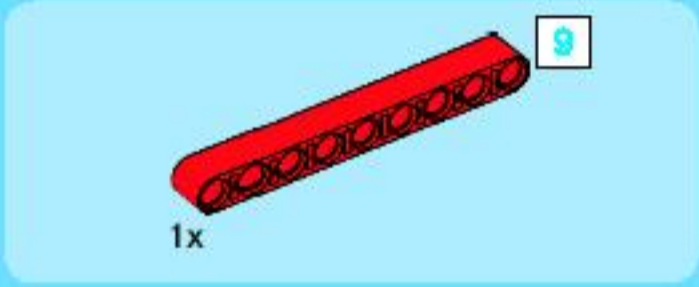
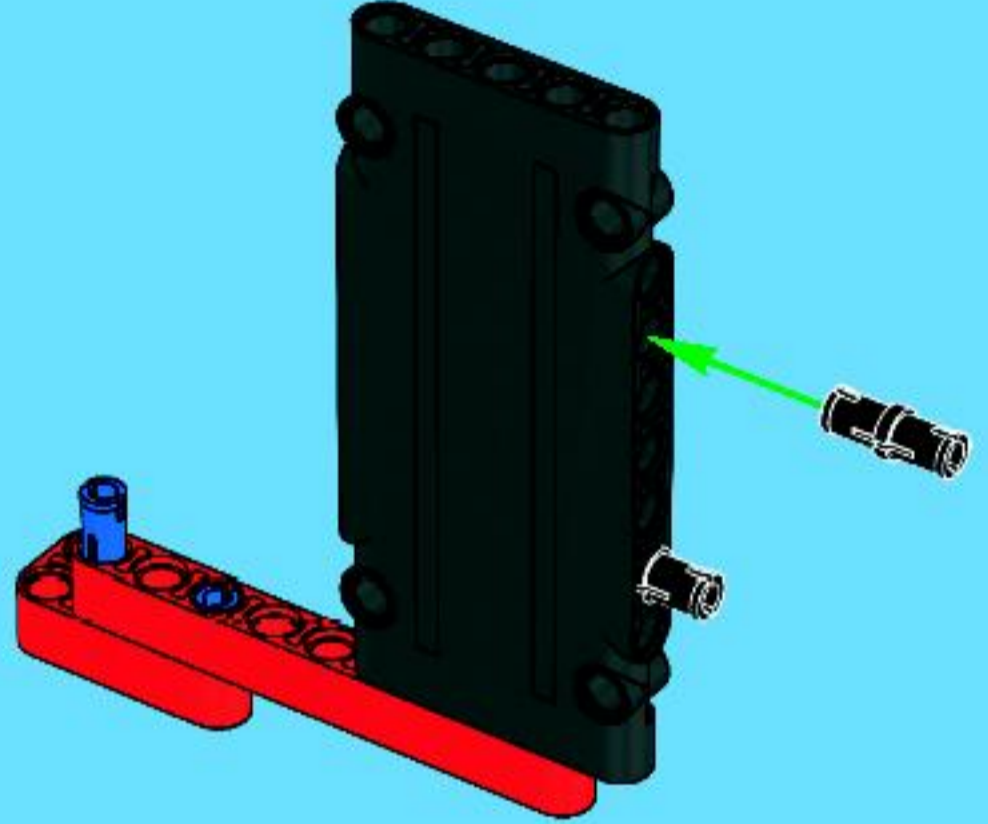

2

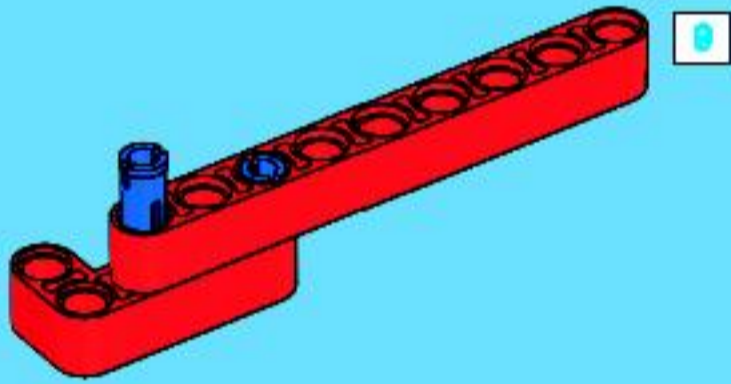

3

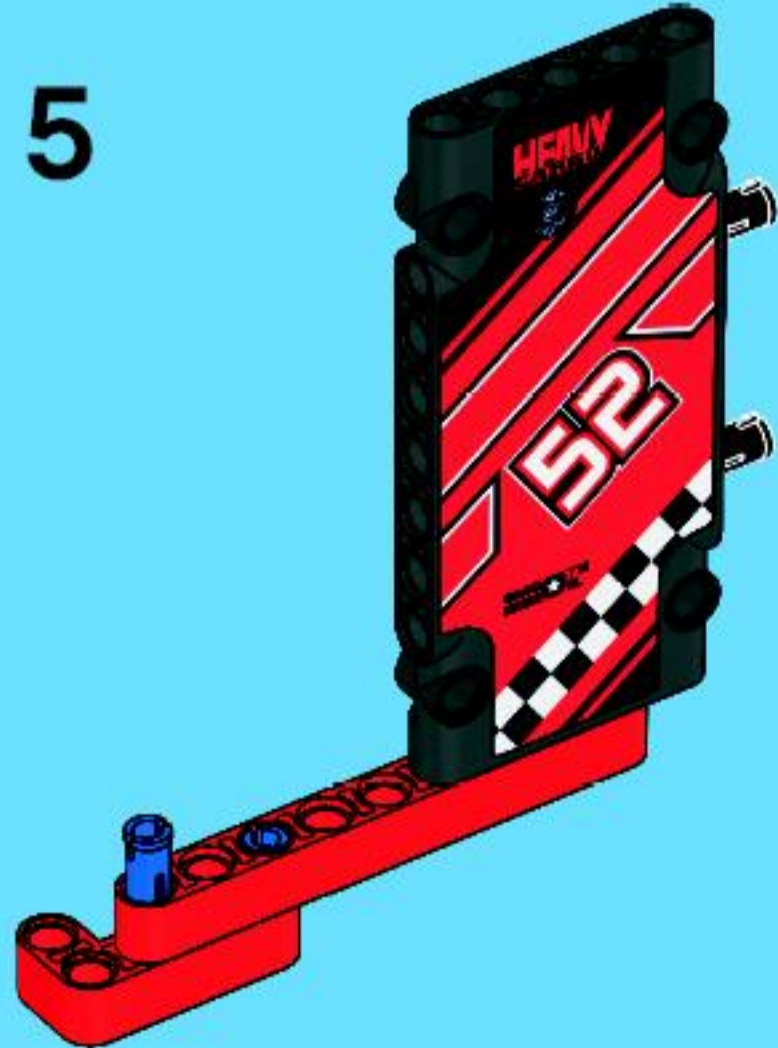
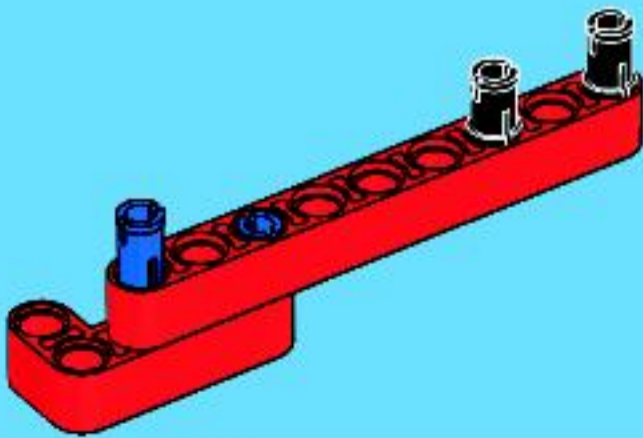

5

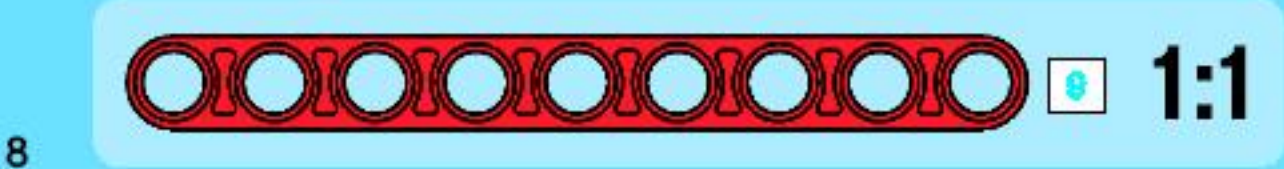

8



53

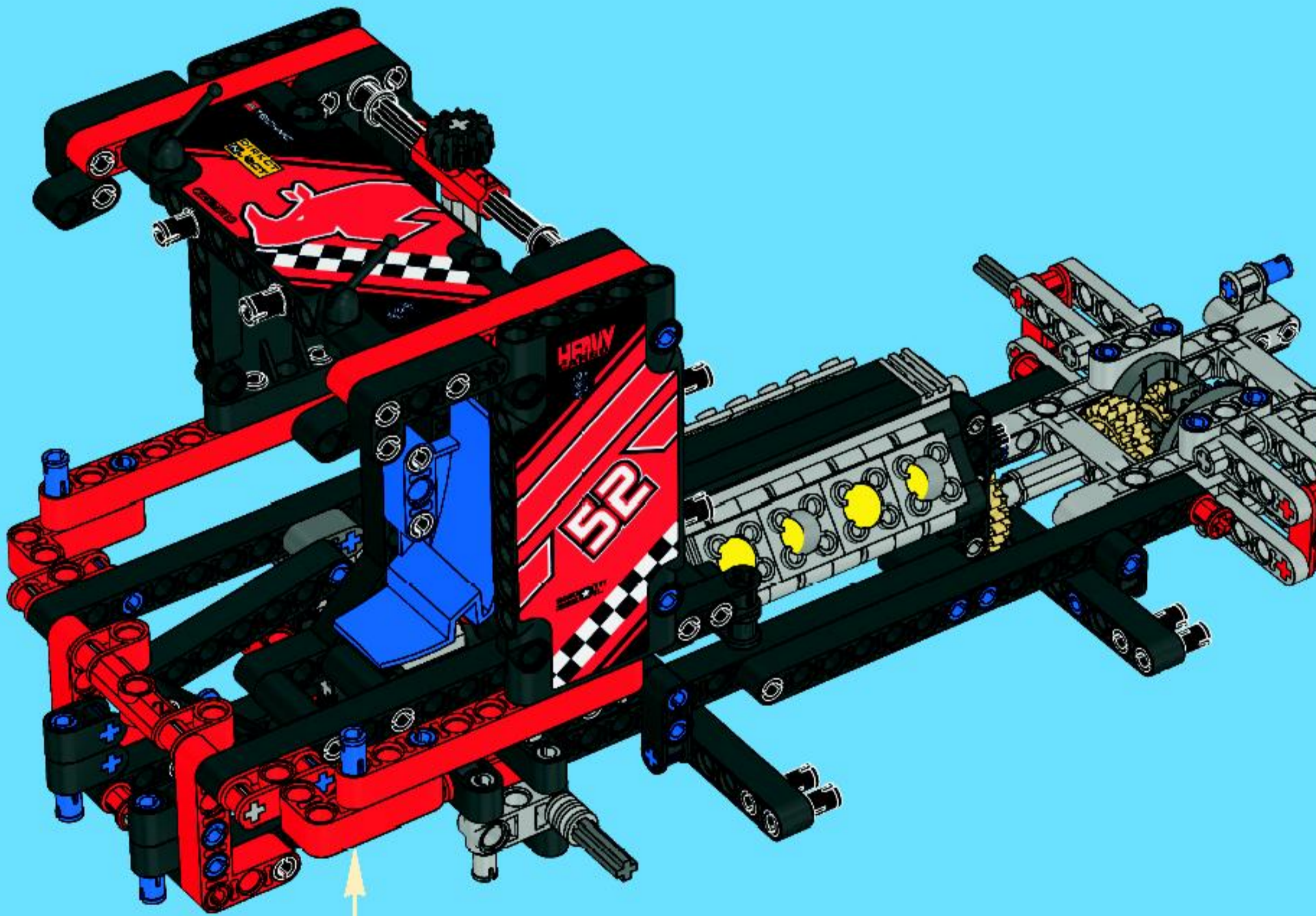



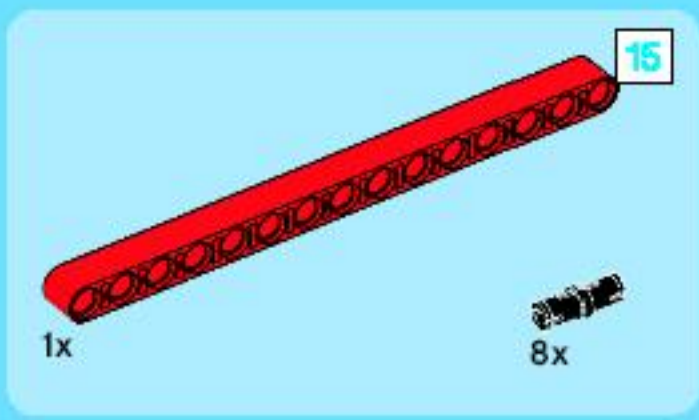

# 54

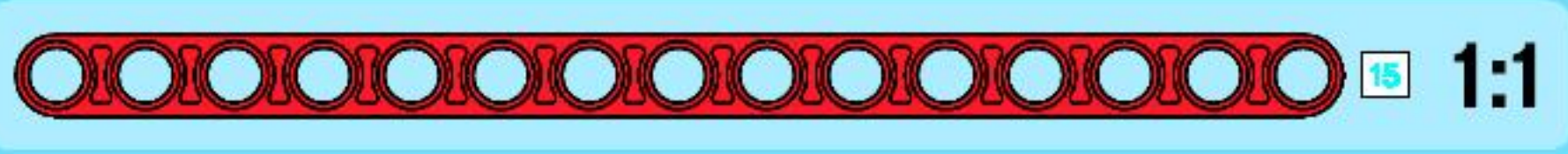
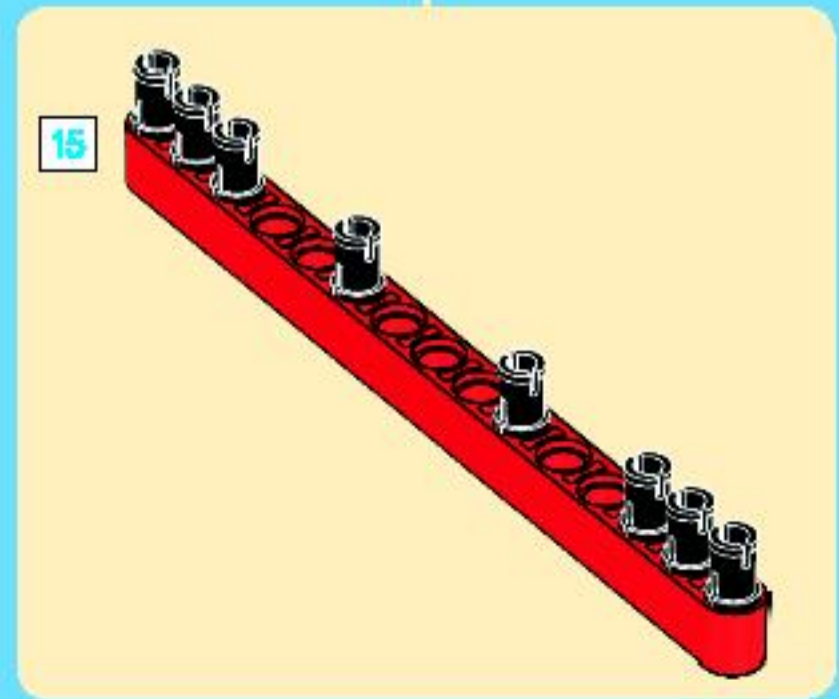
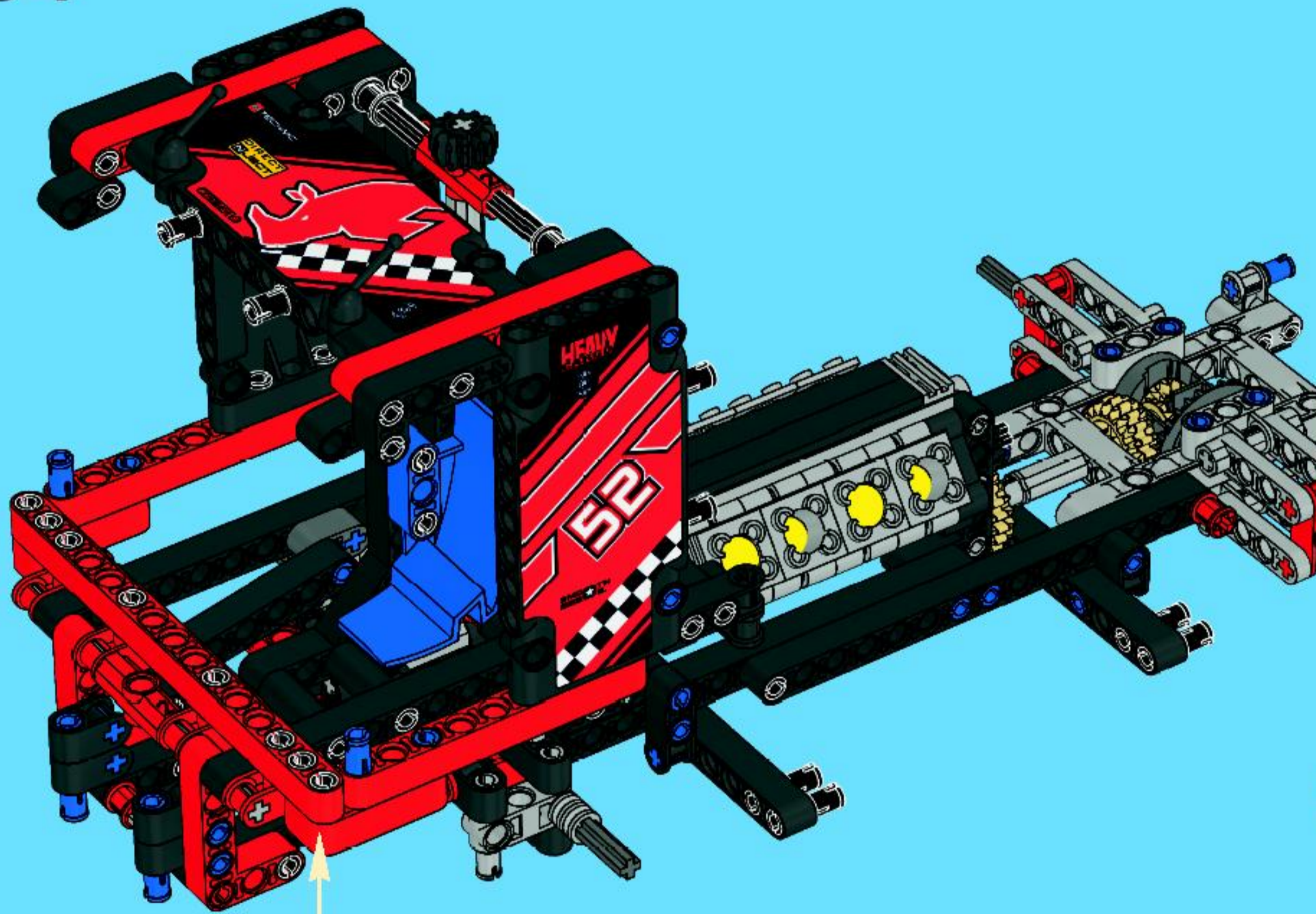



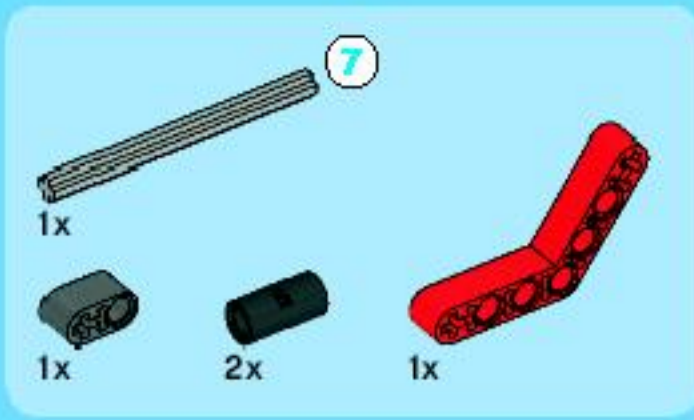

55

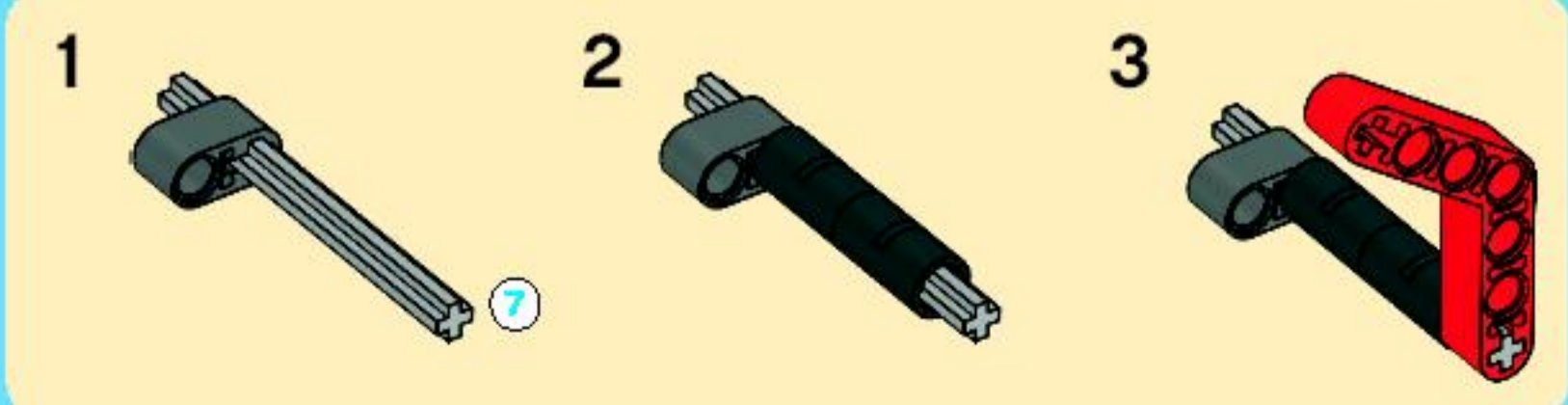
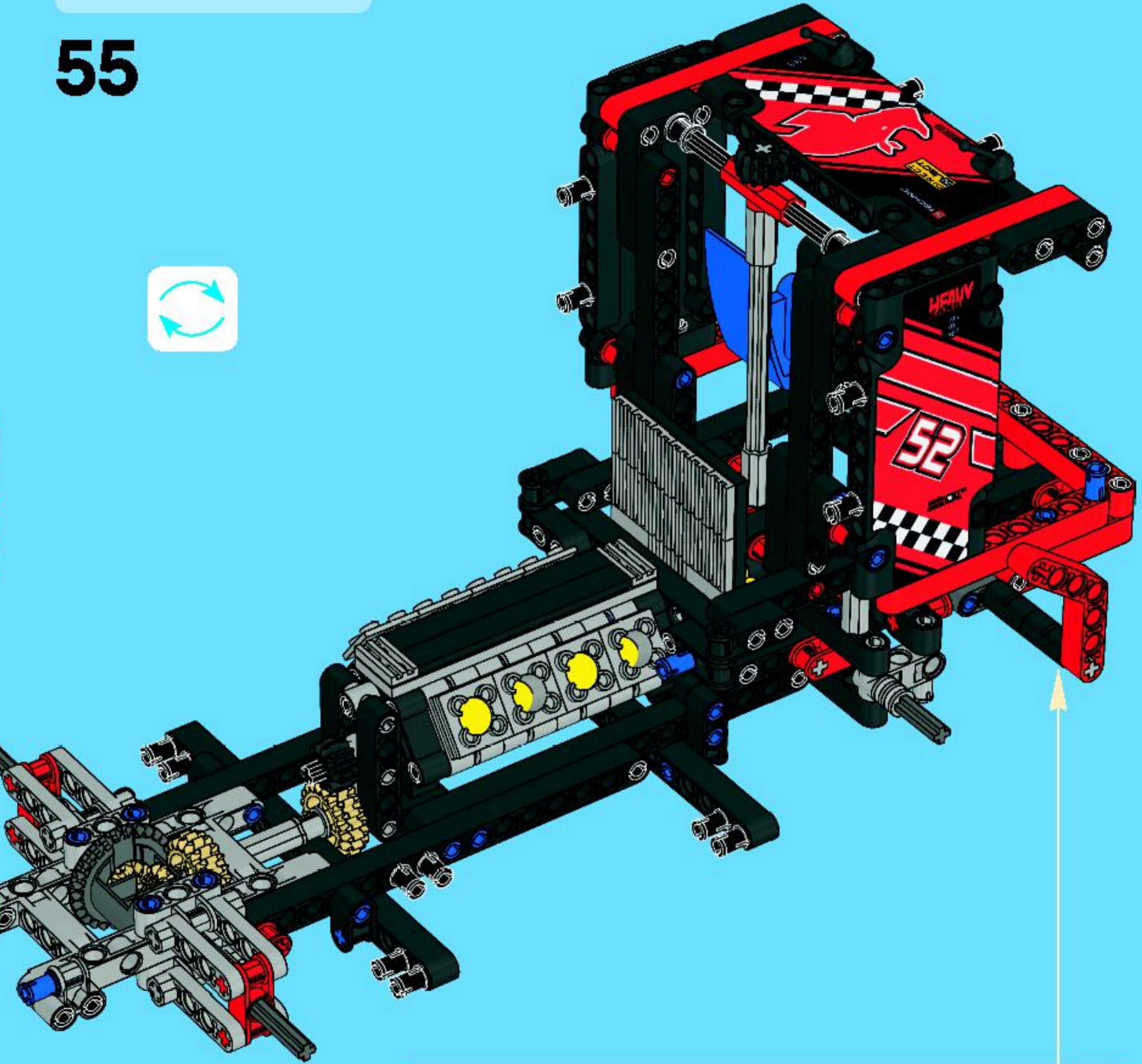



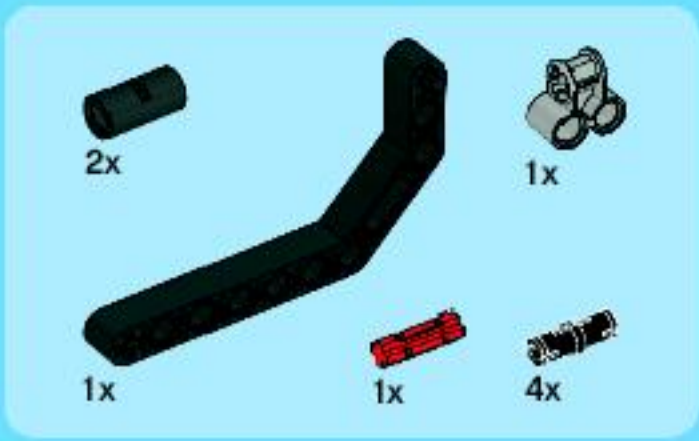

1



2



3



4



5

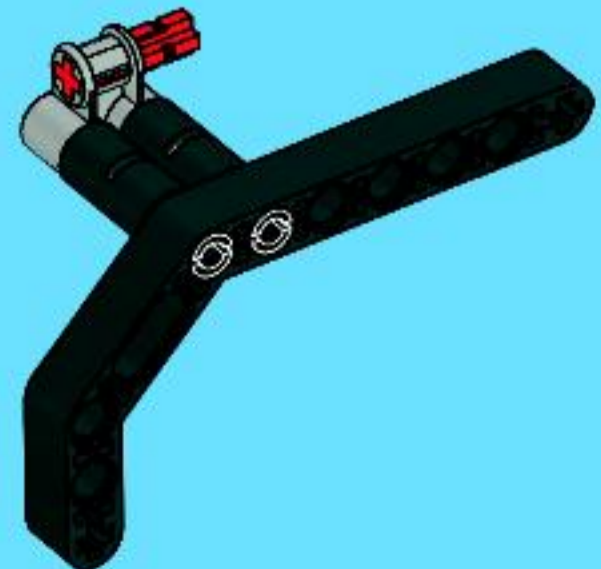



56

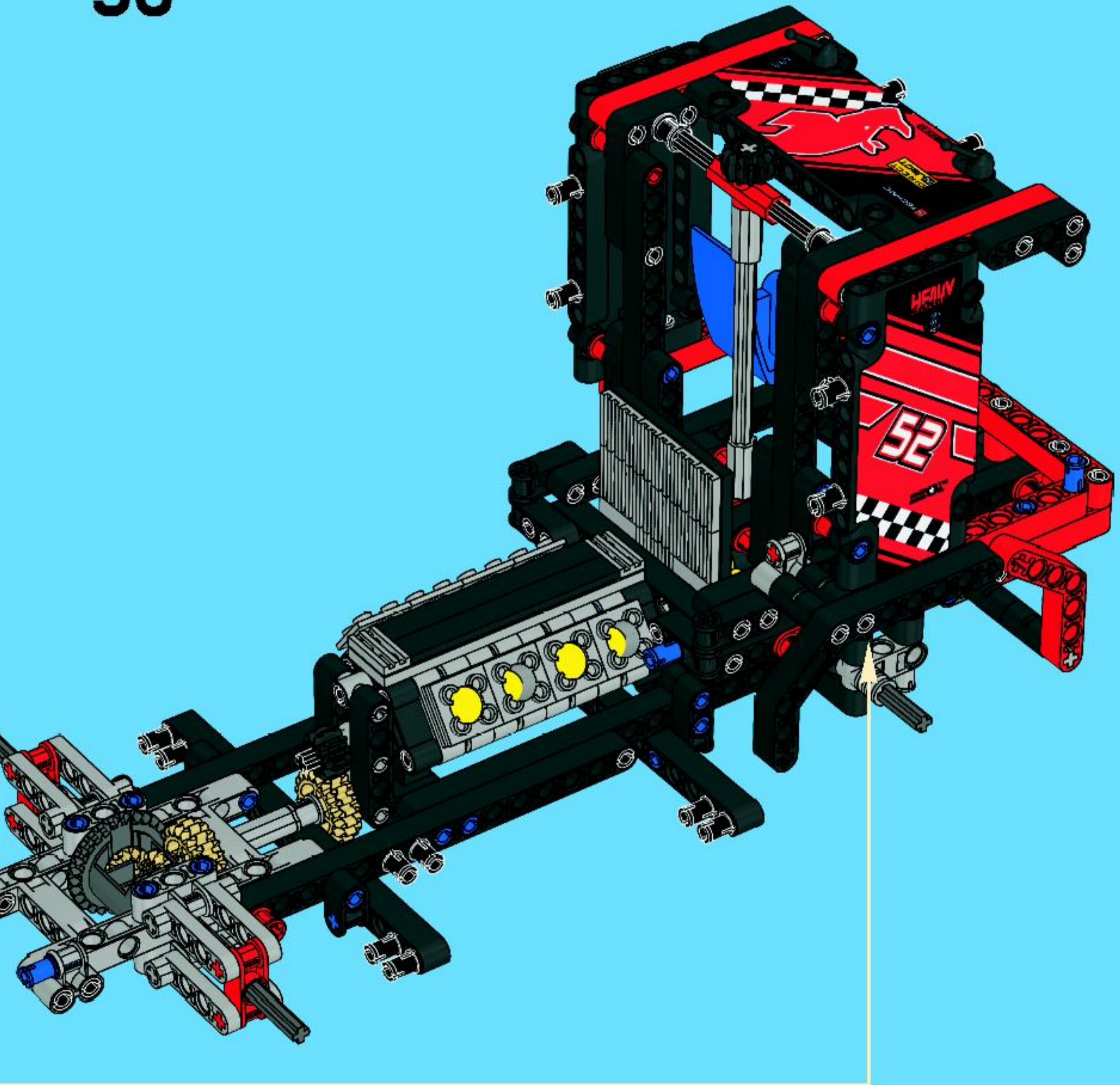



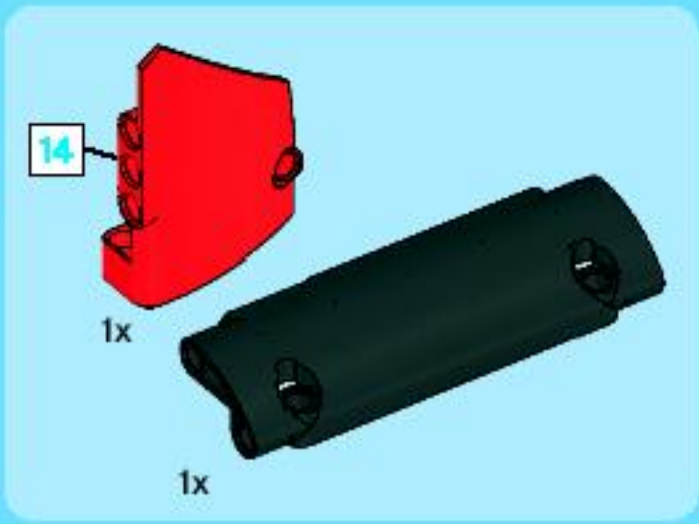

57

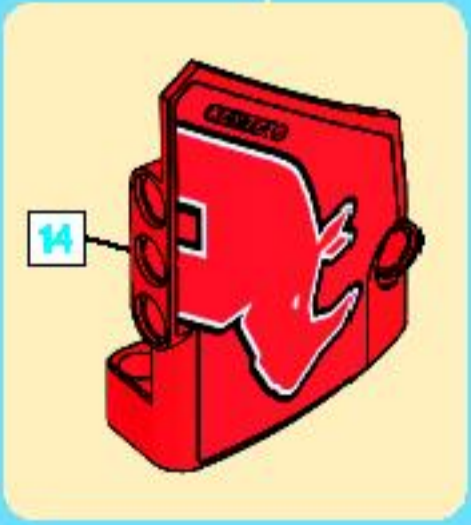
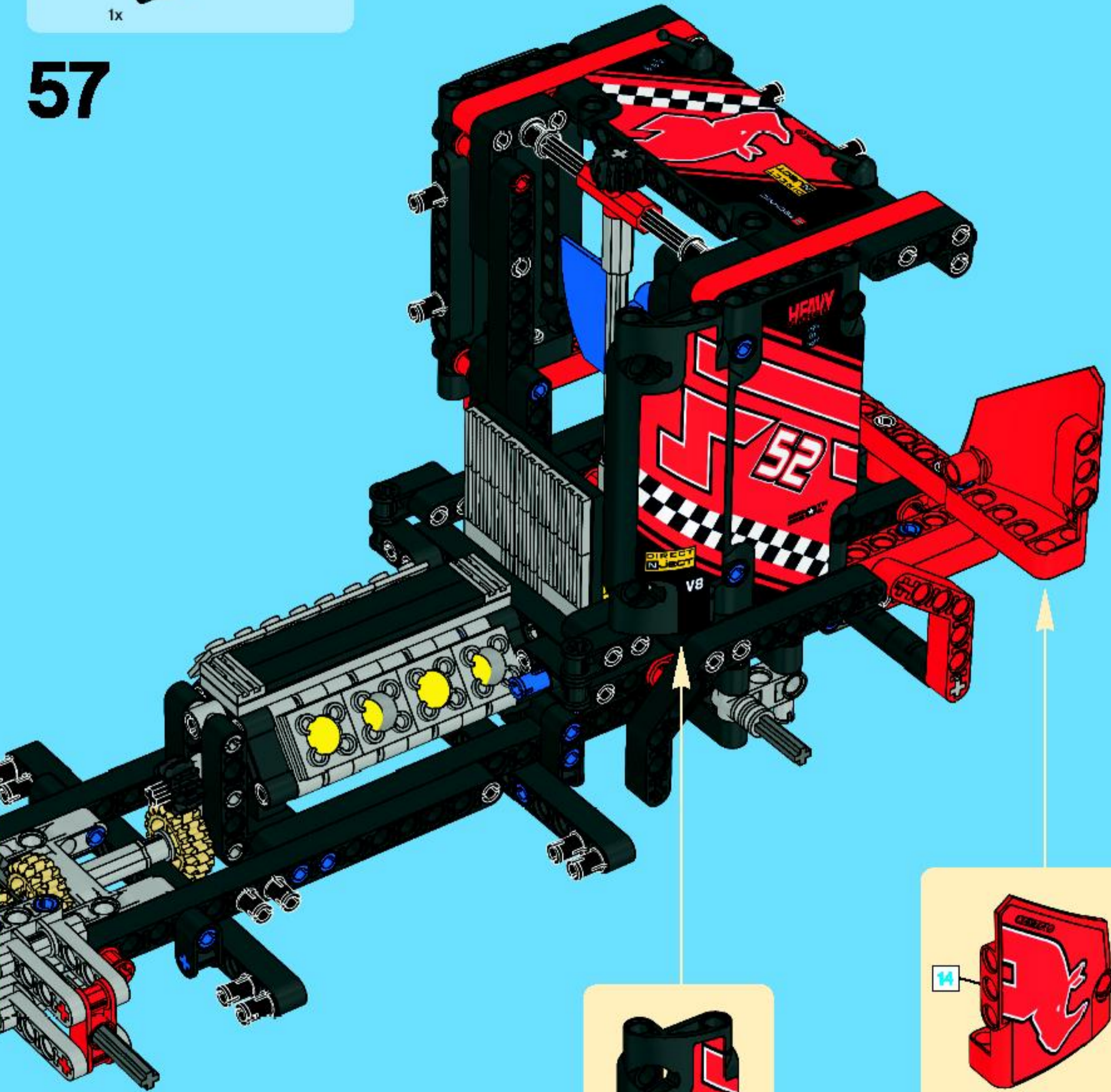



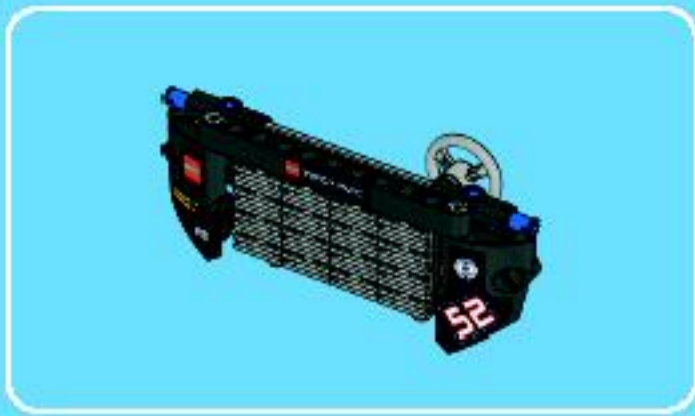

1

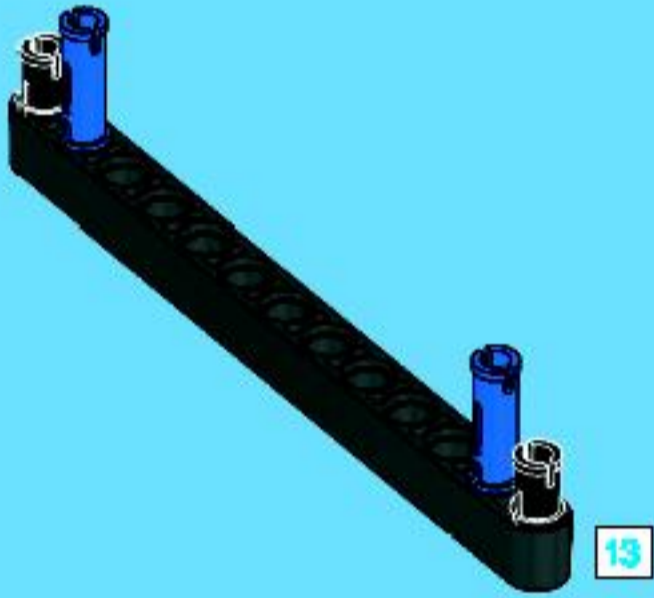

2

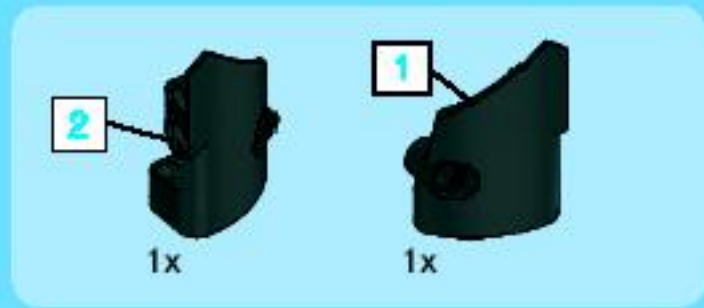
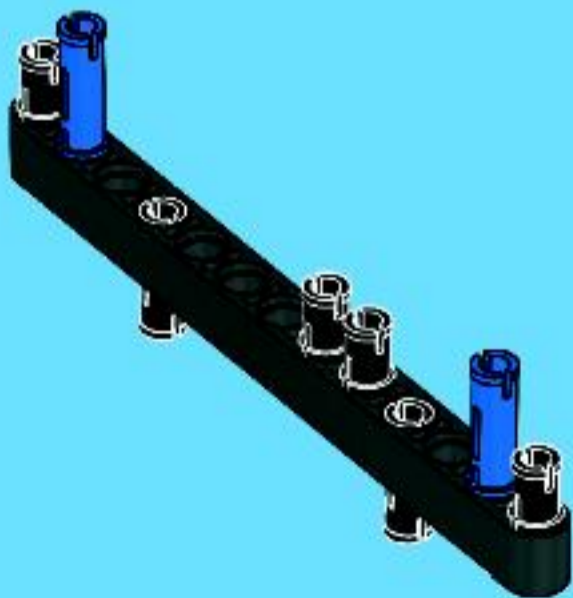

3

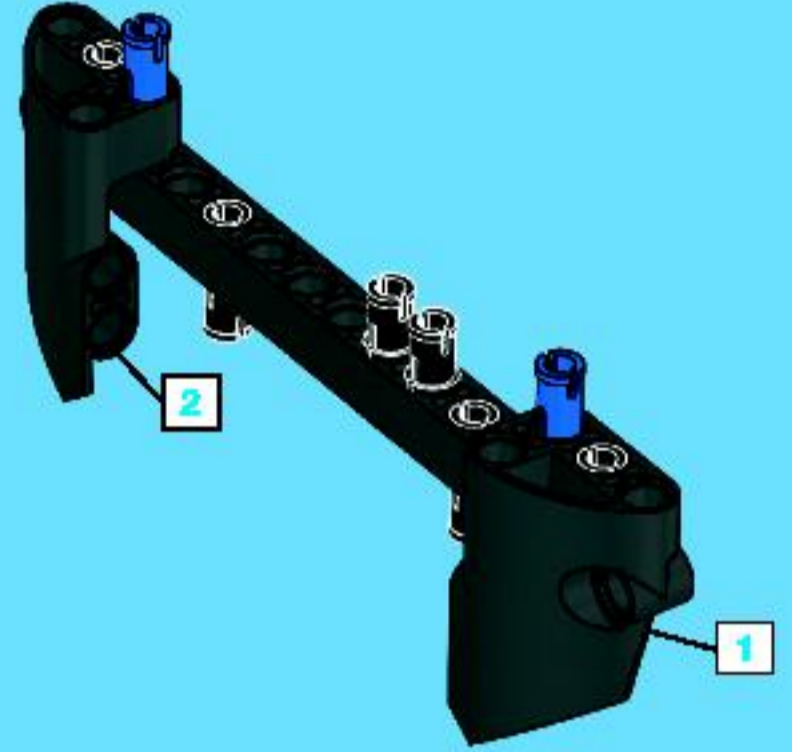

4

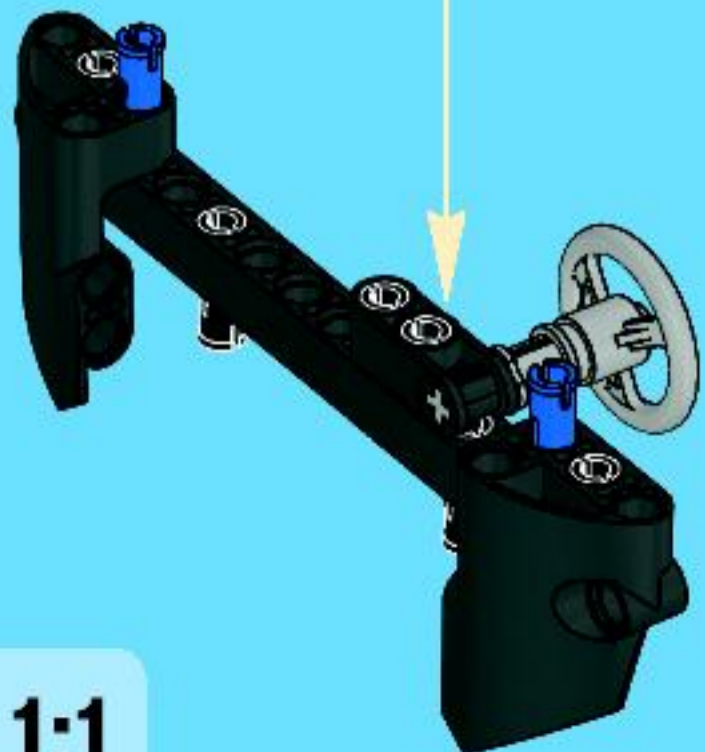
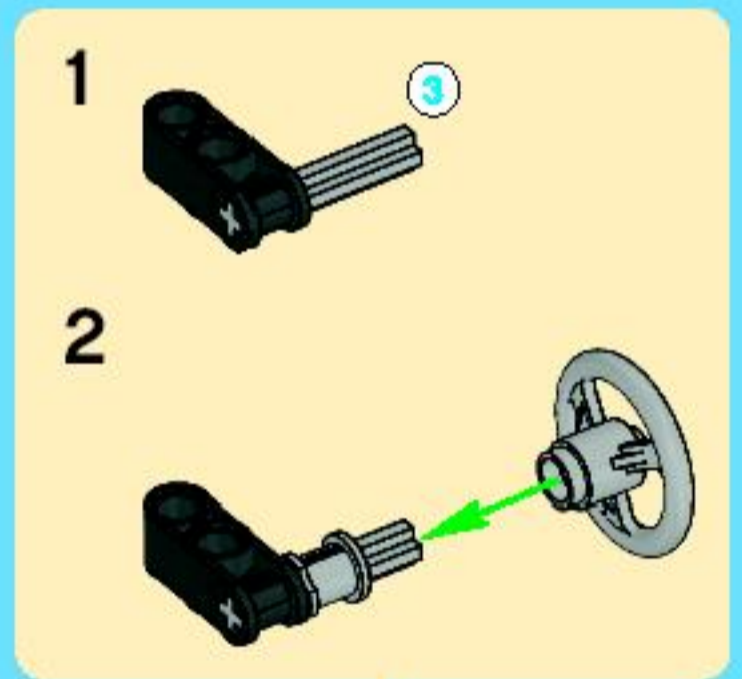



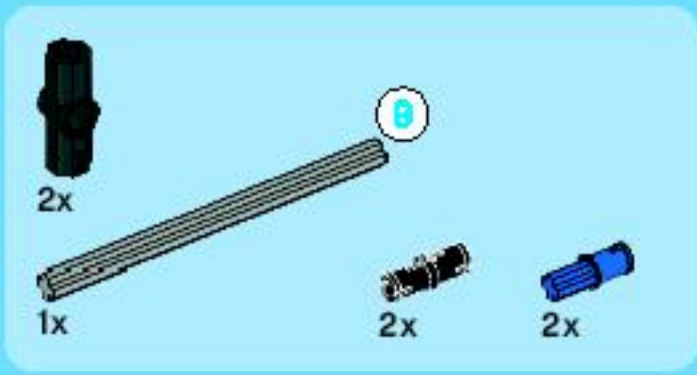

5

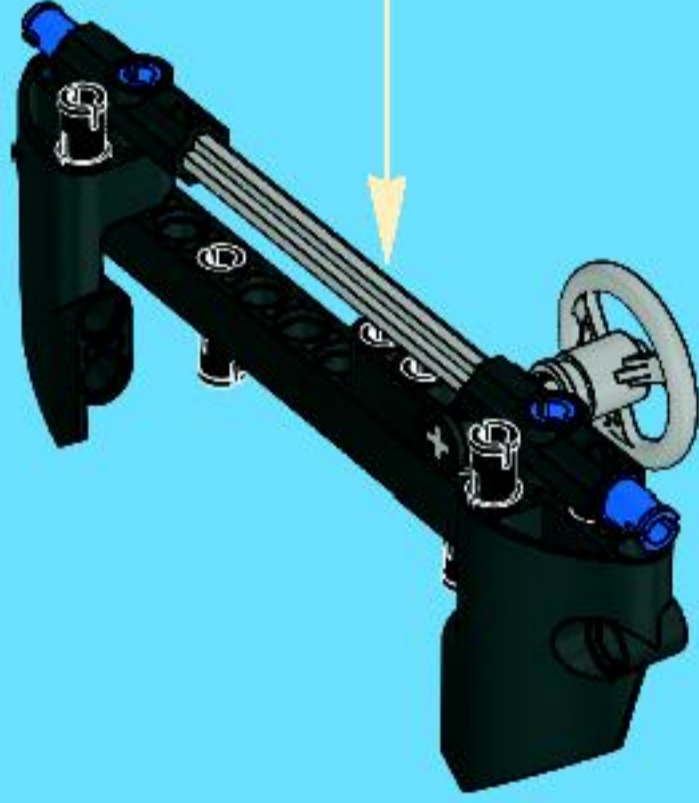
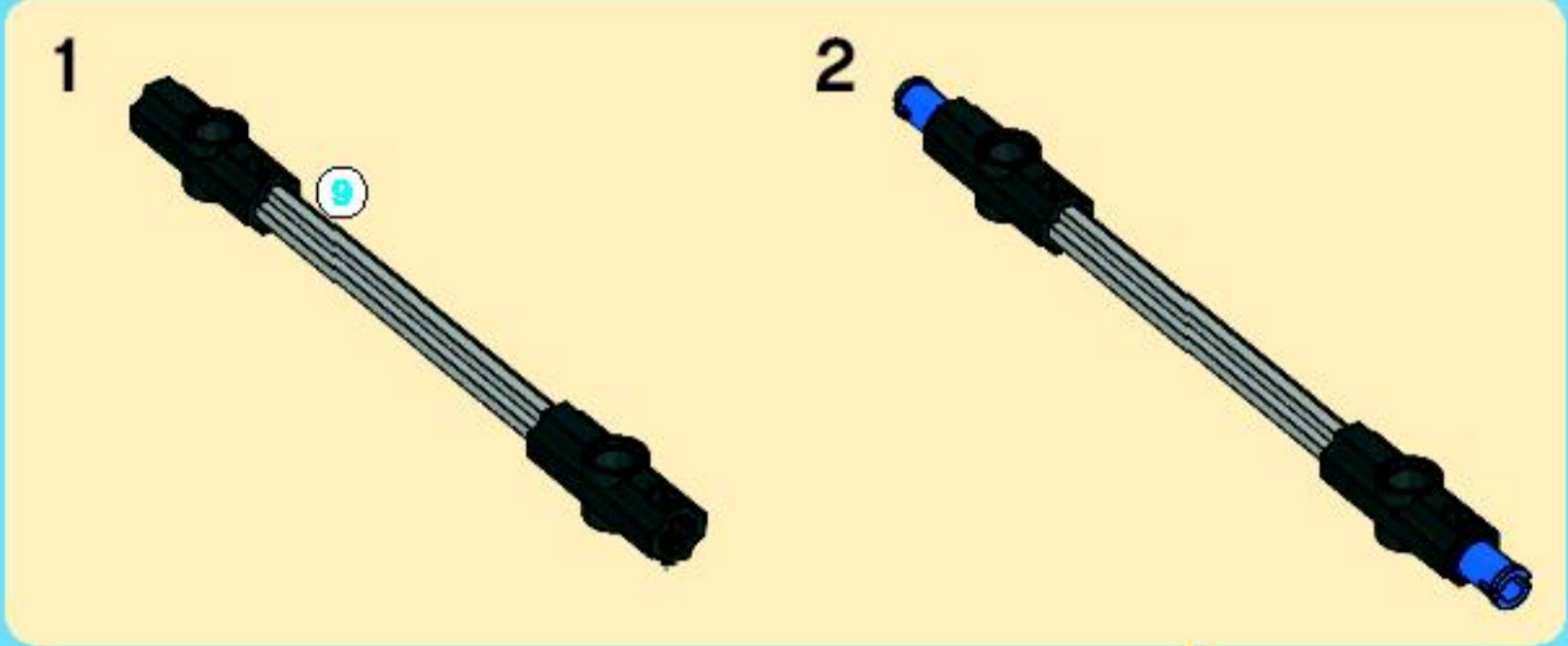

6

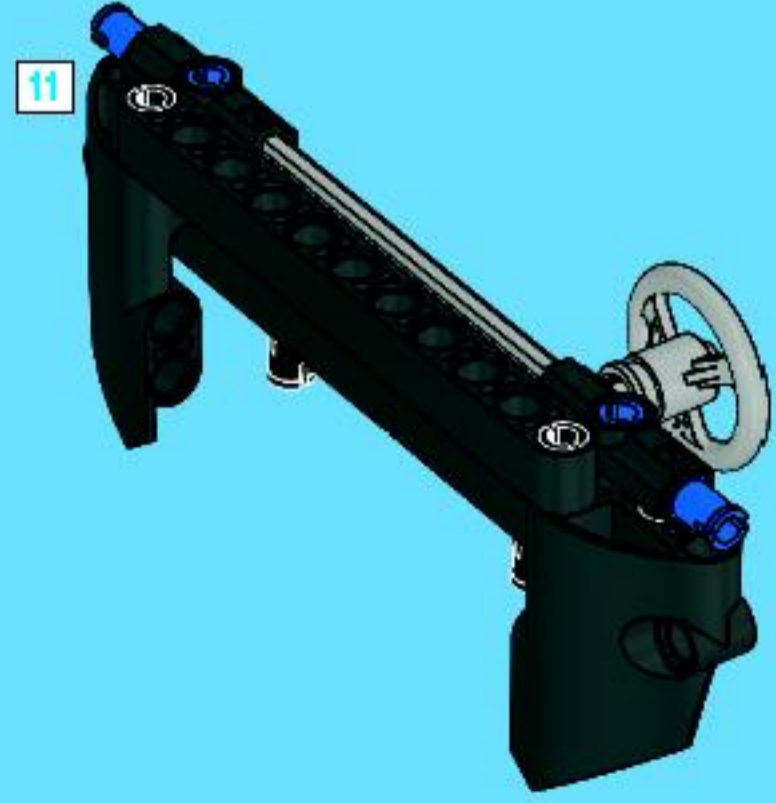



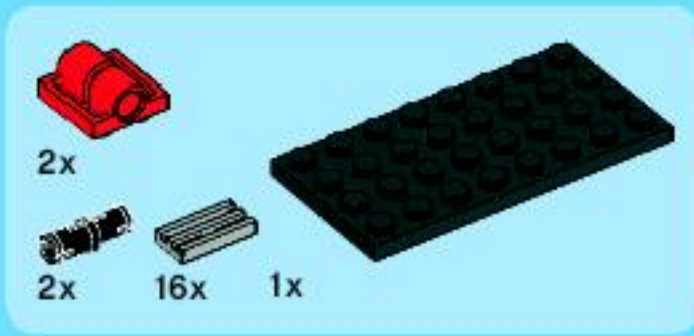

7

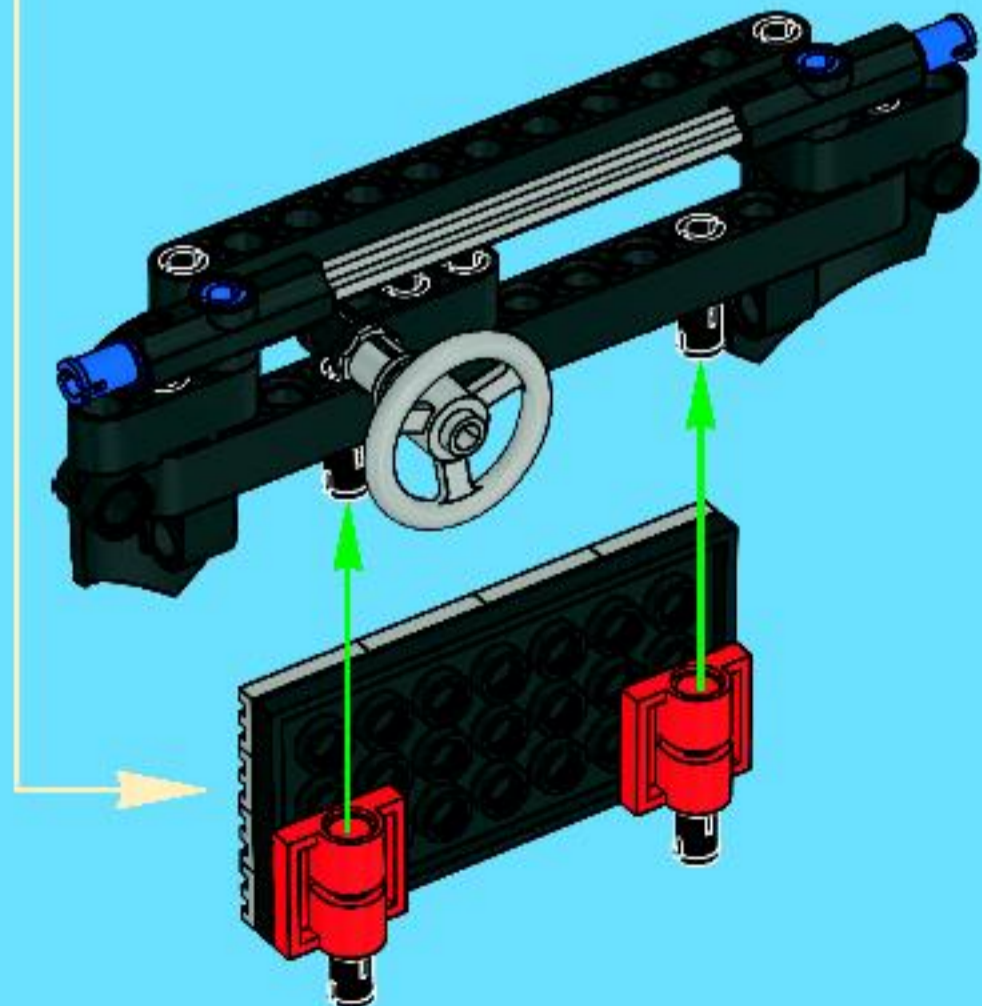
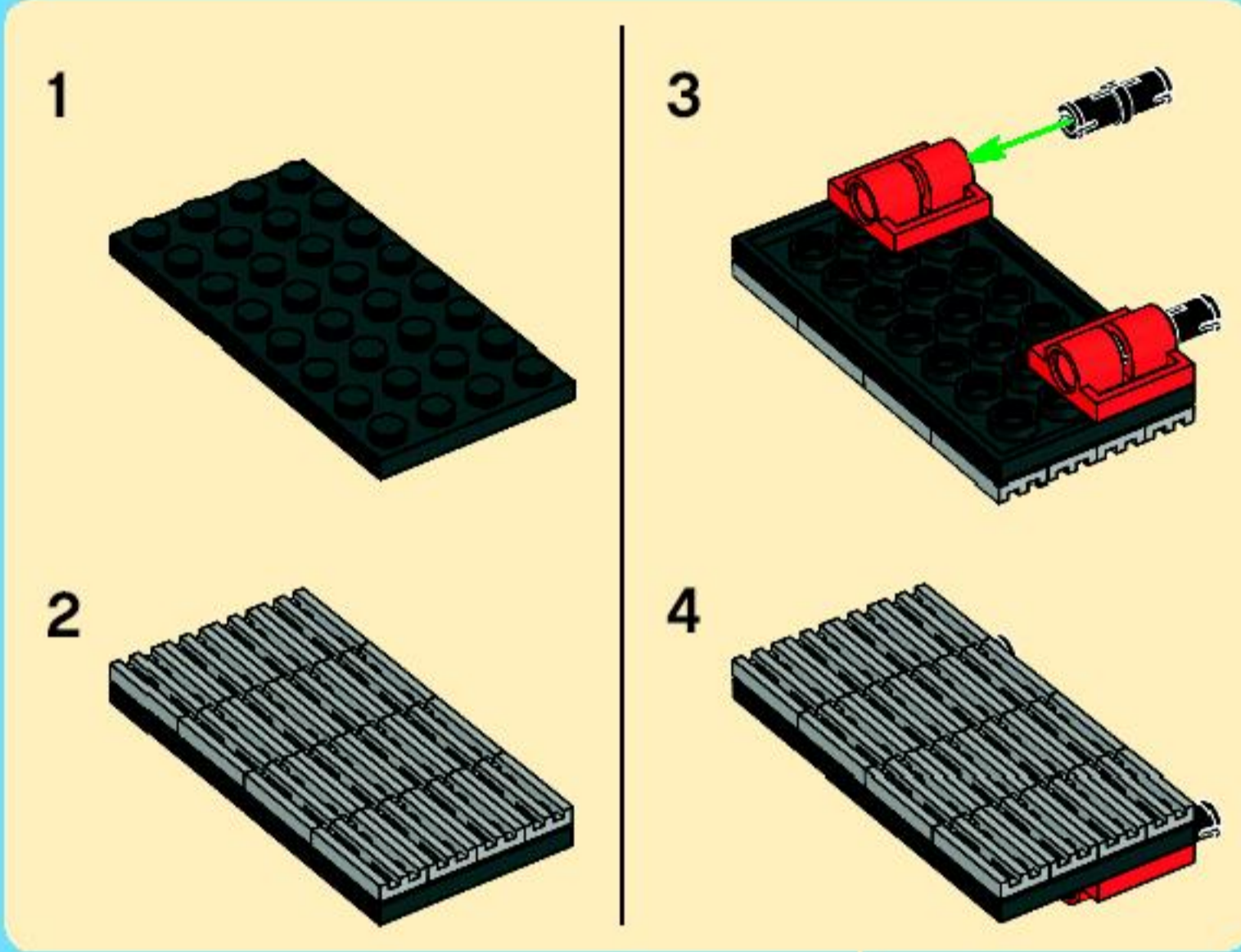



8

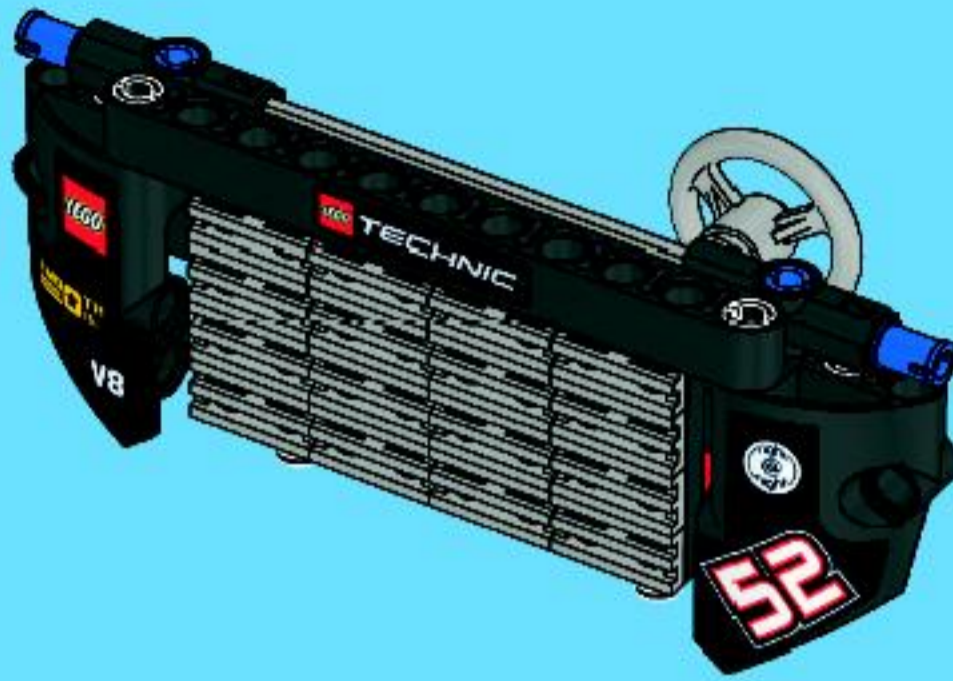

58

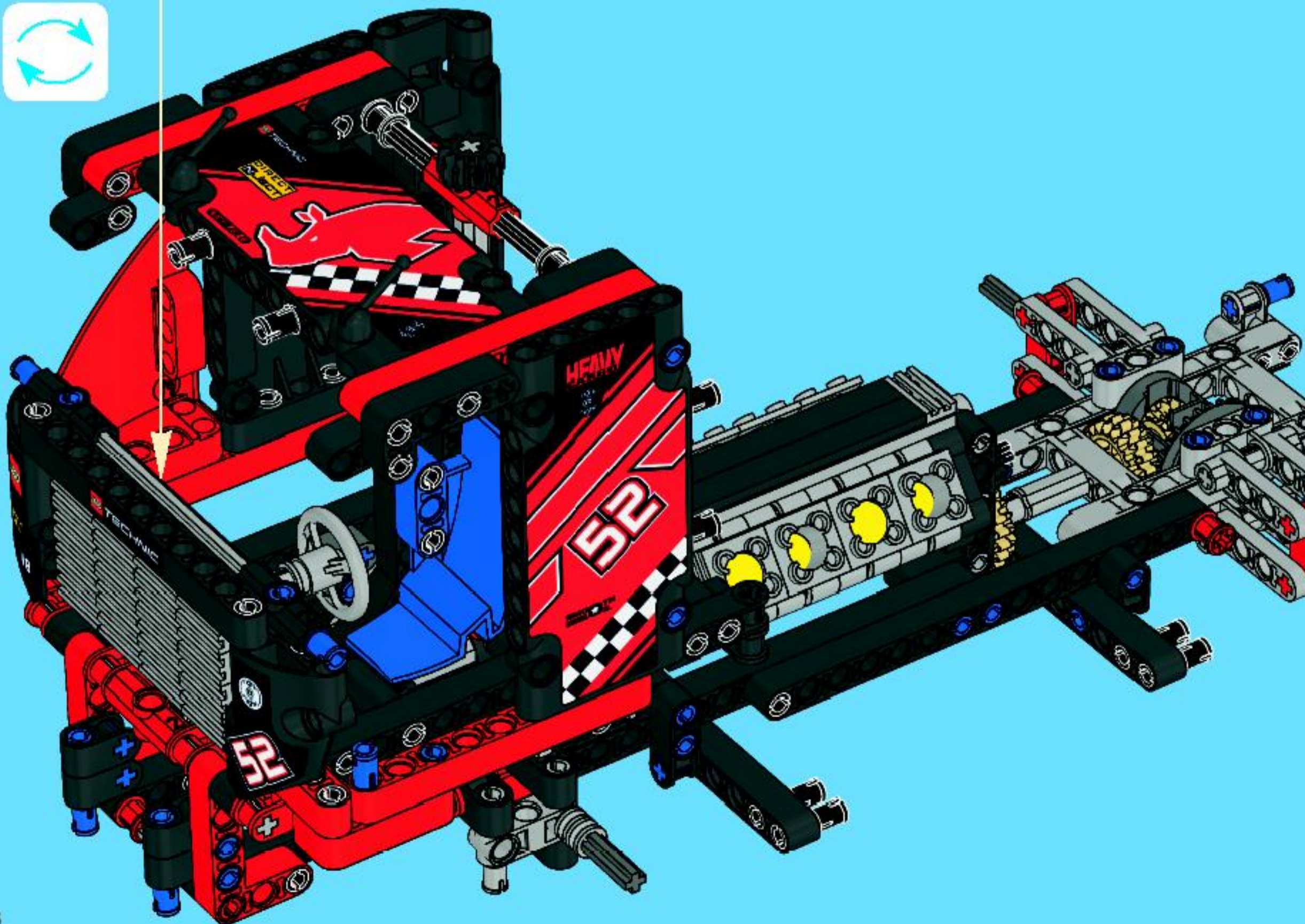



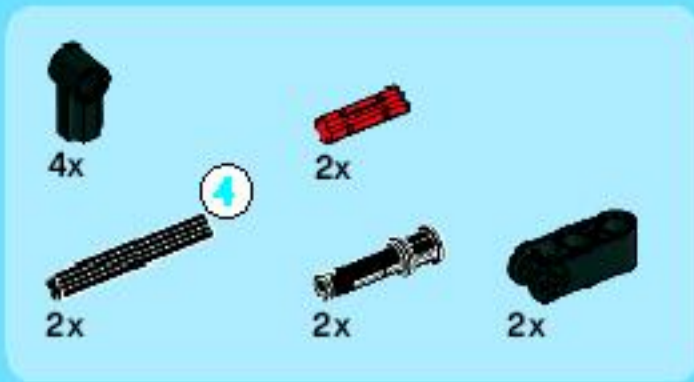

# 59

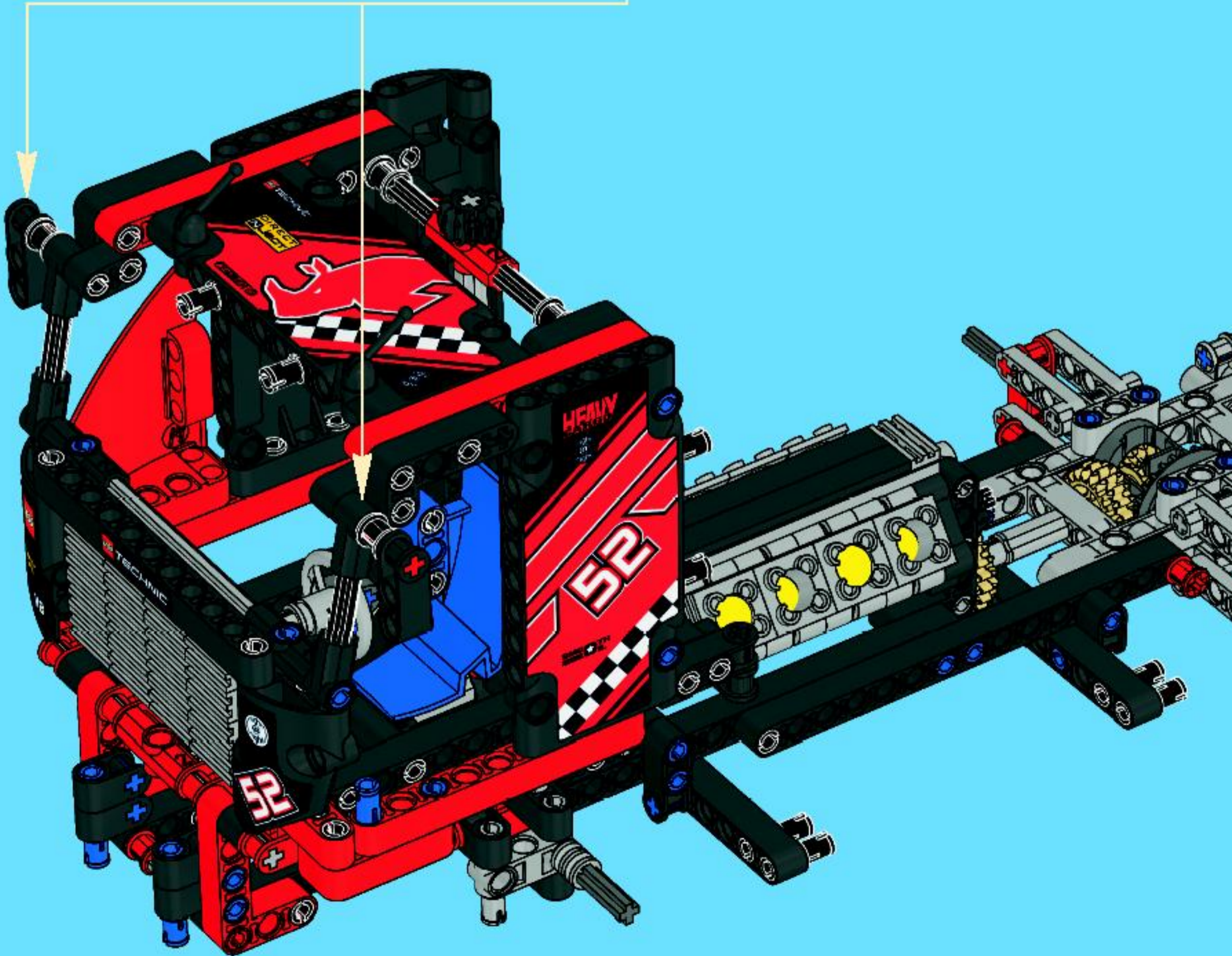
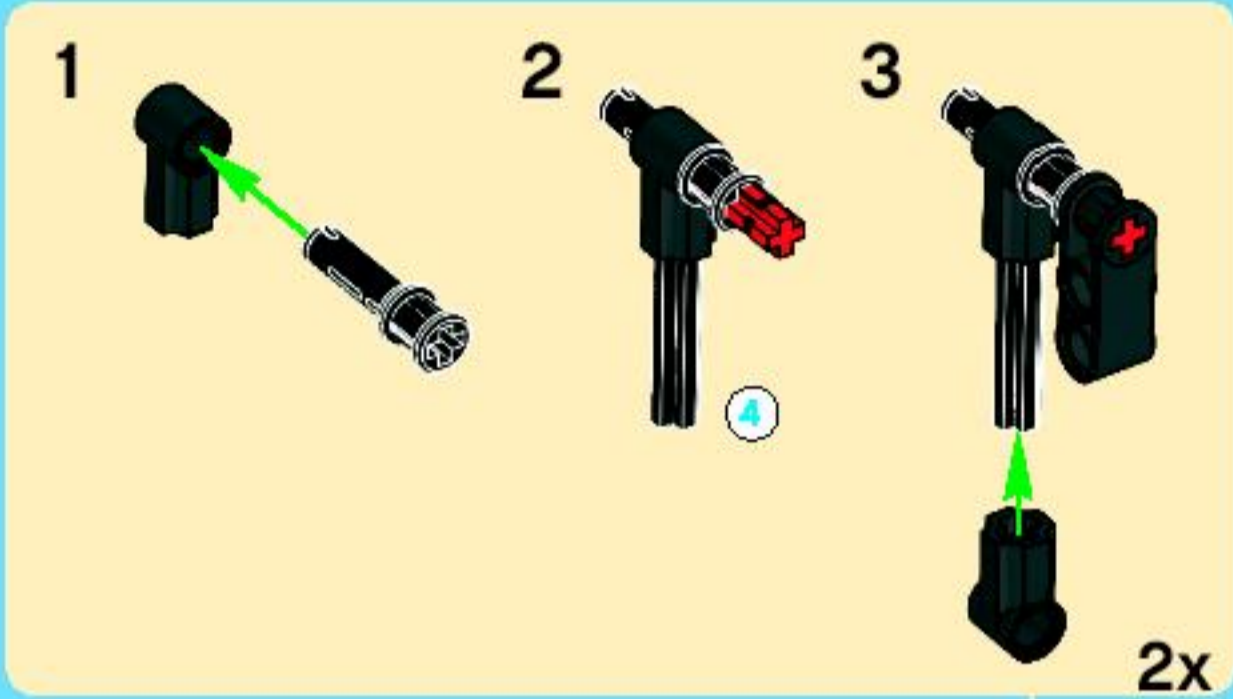





60

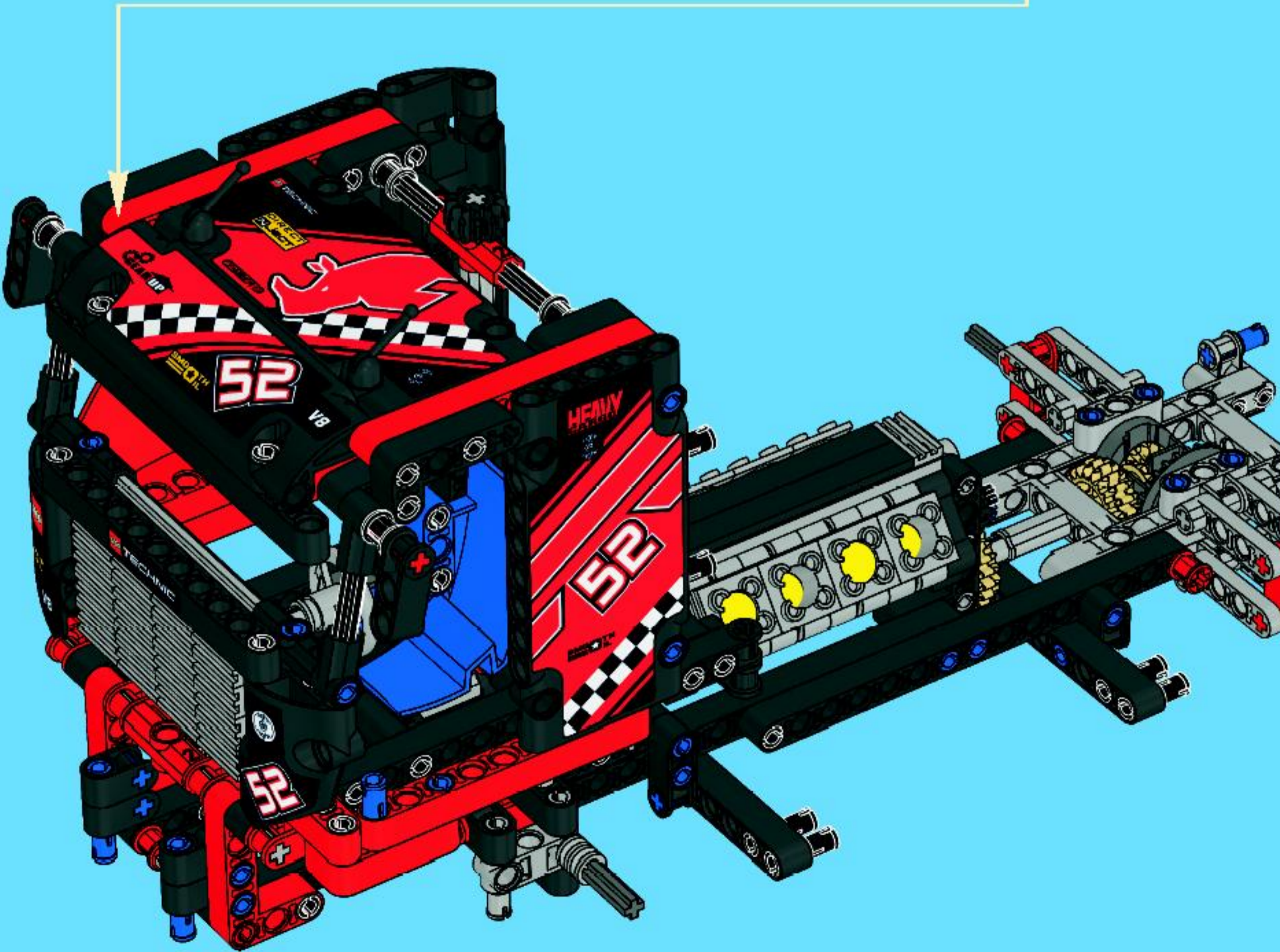
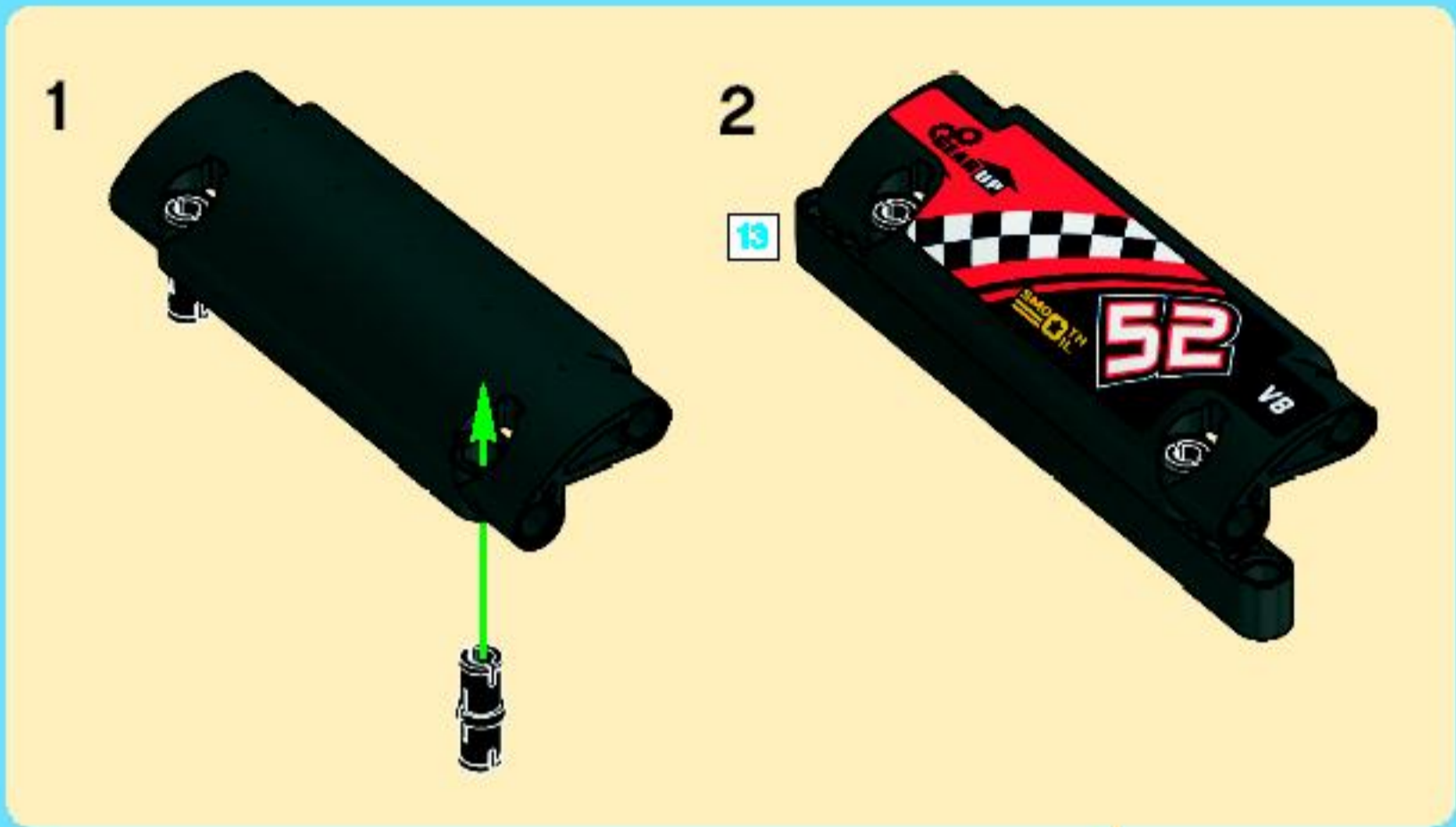



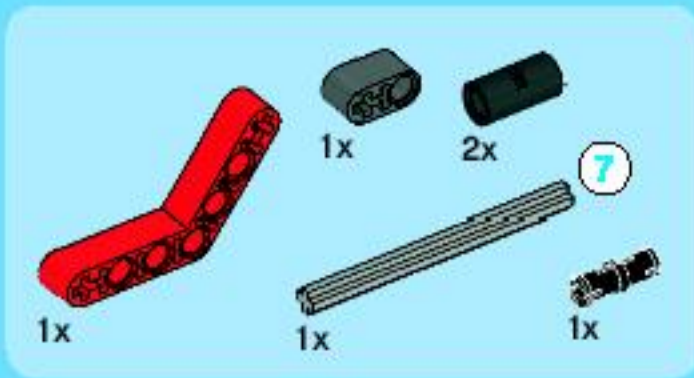

# 61

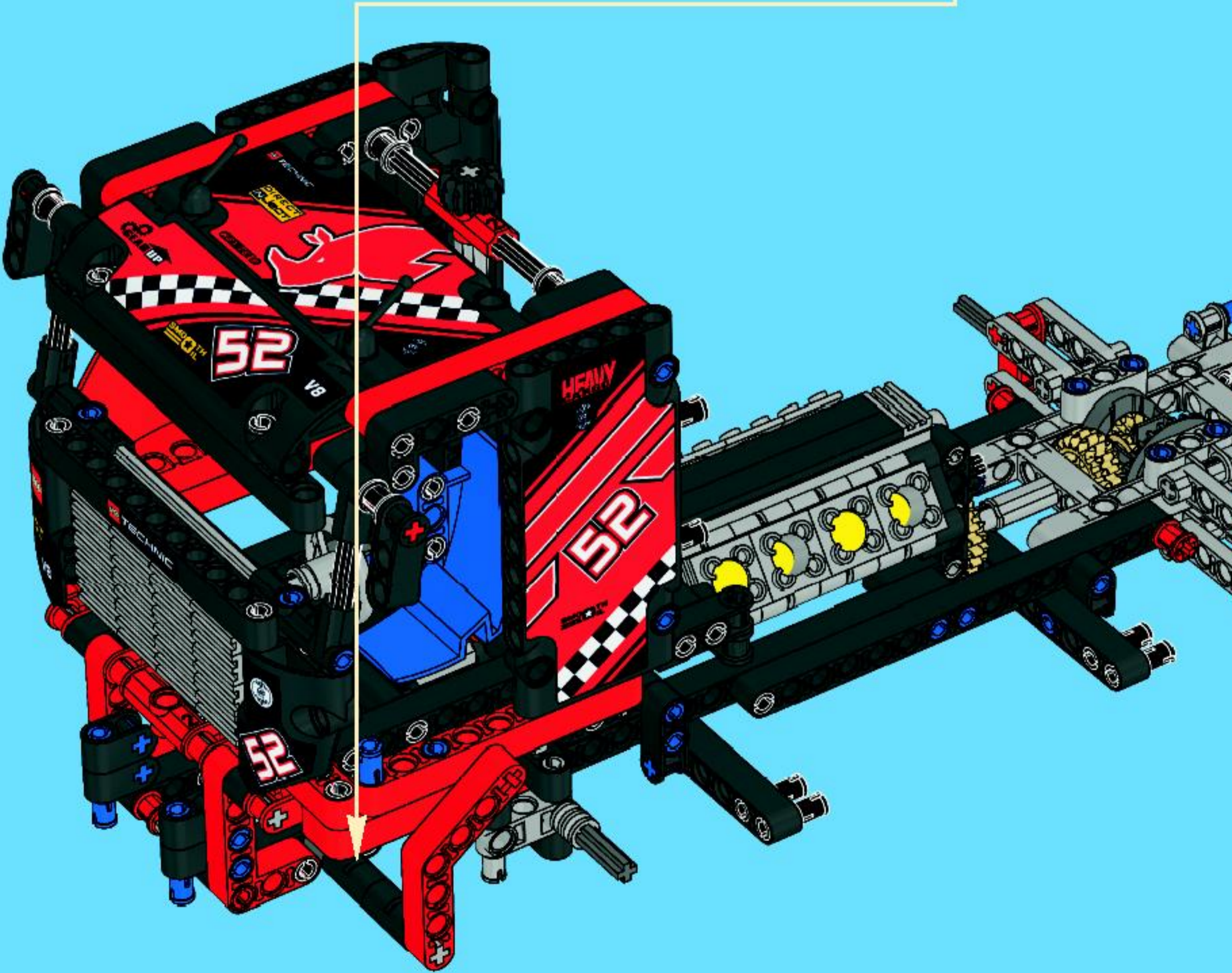
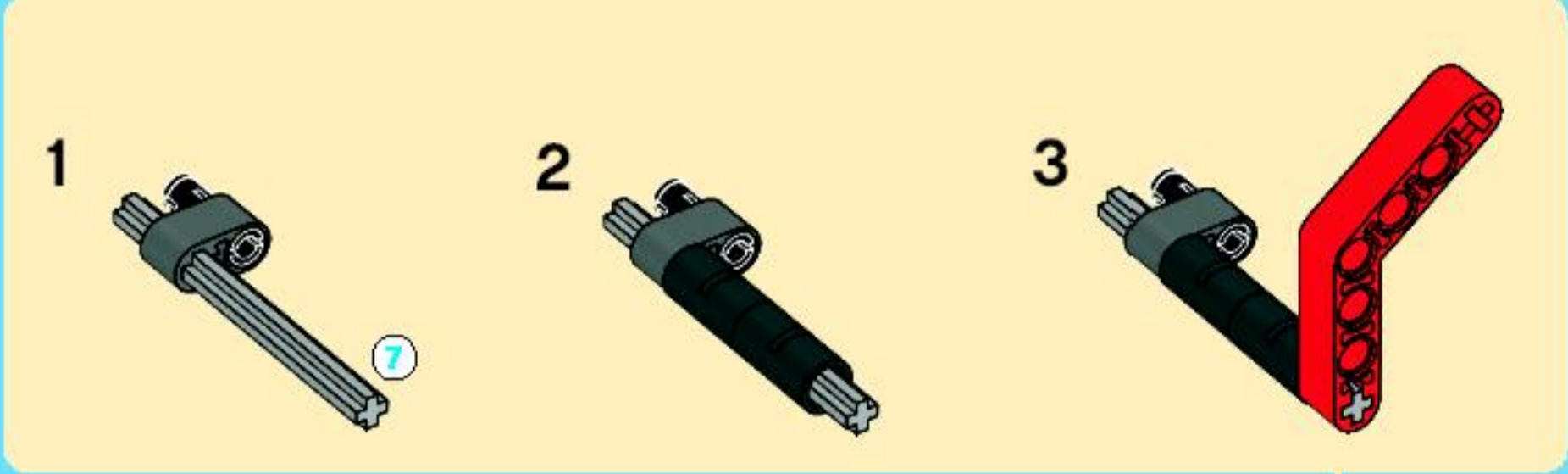



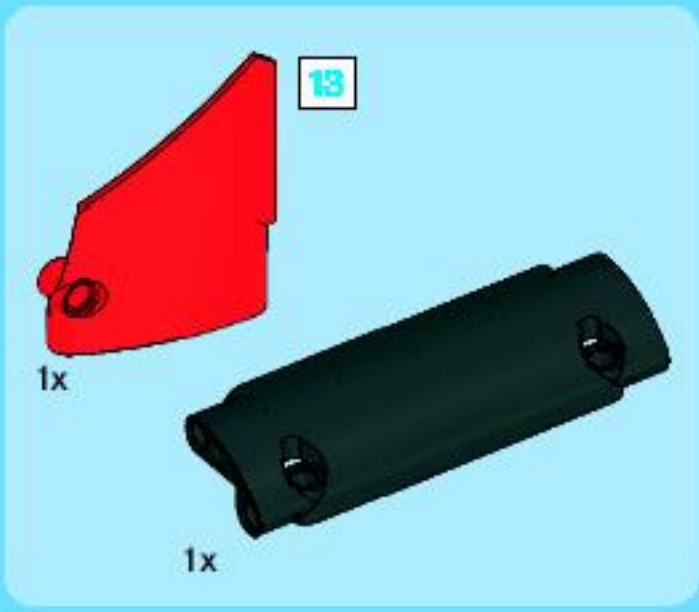

62

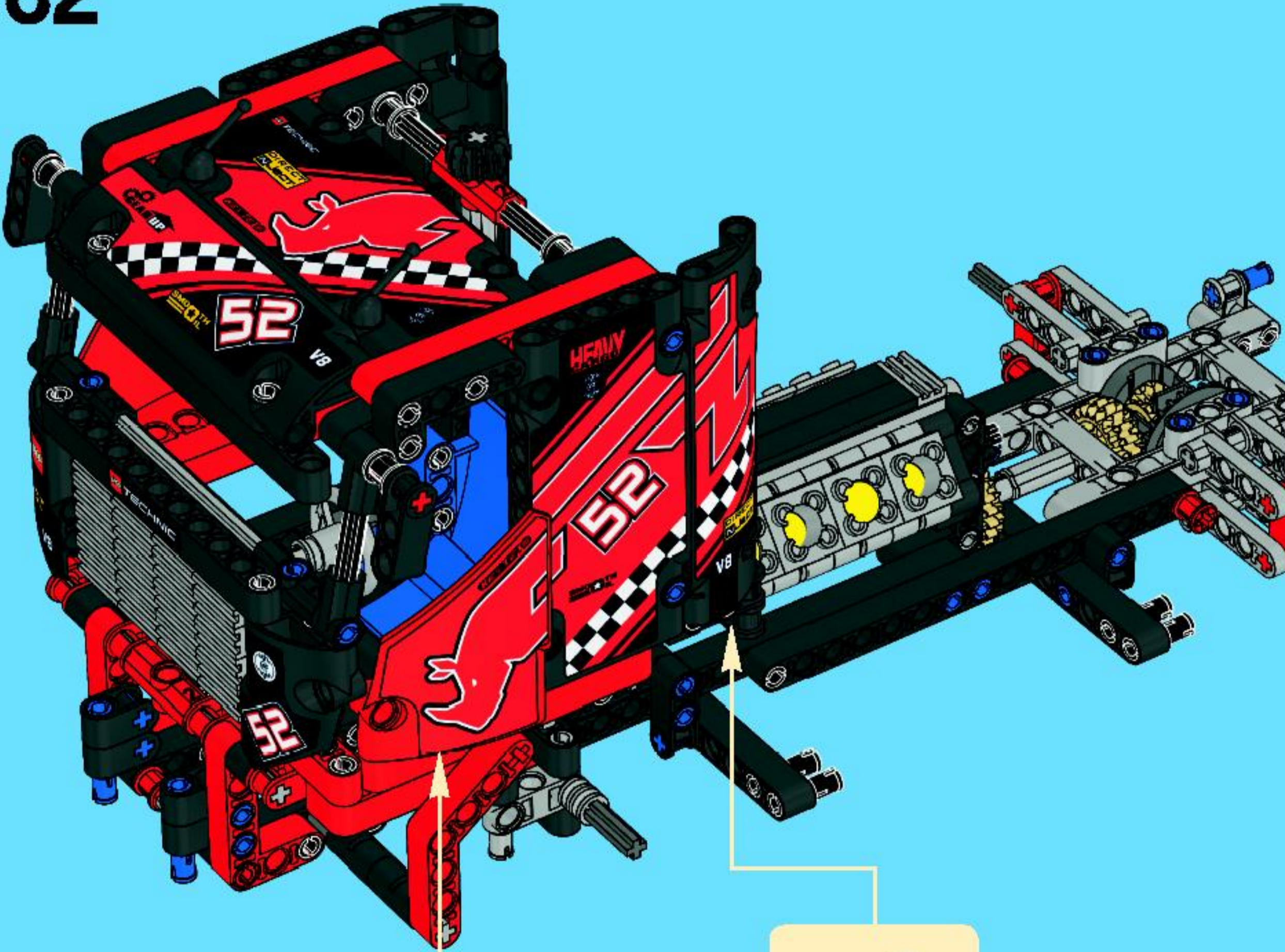





1



2



3



4

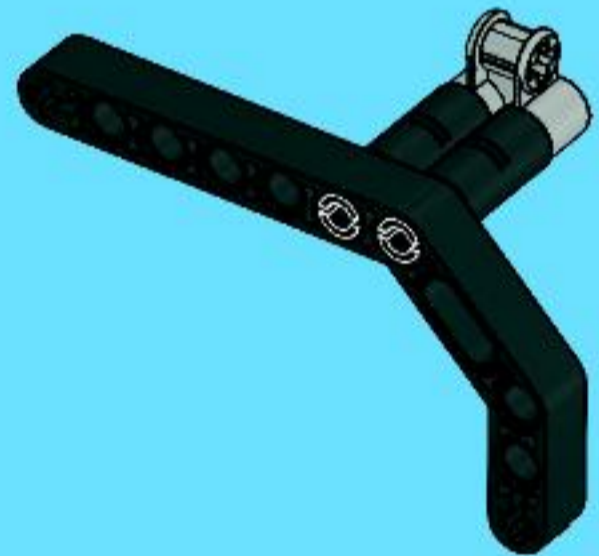

5

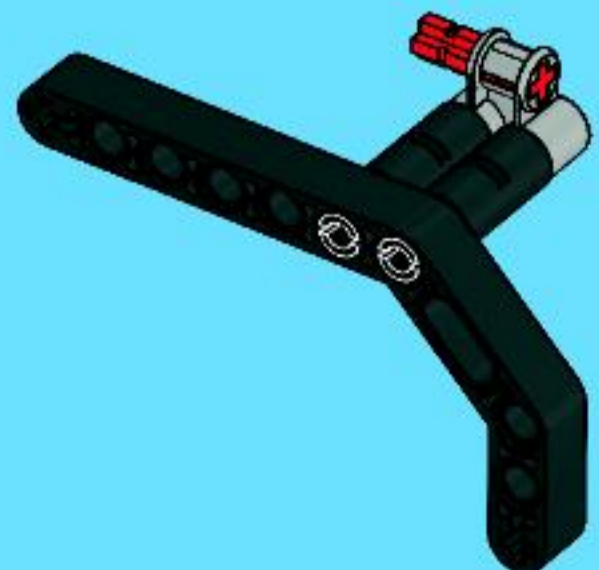



63

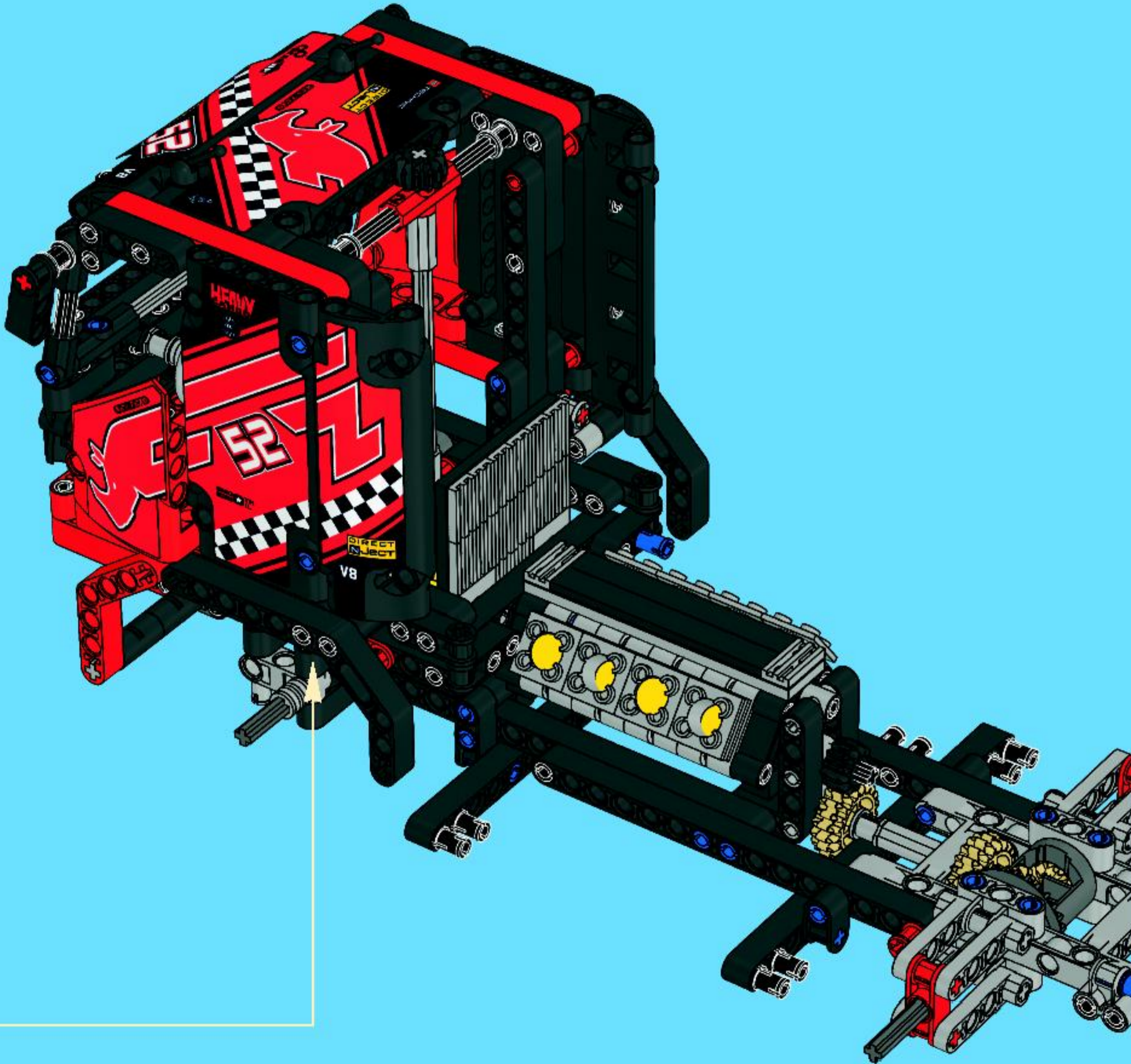





2x

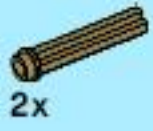

2x

# 64

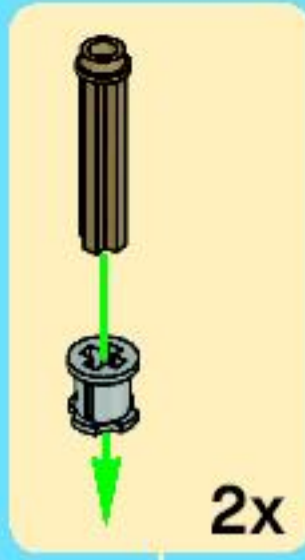

2x

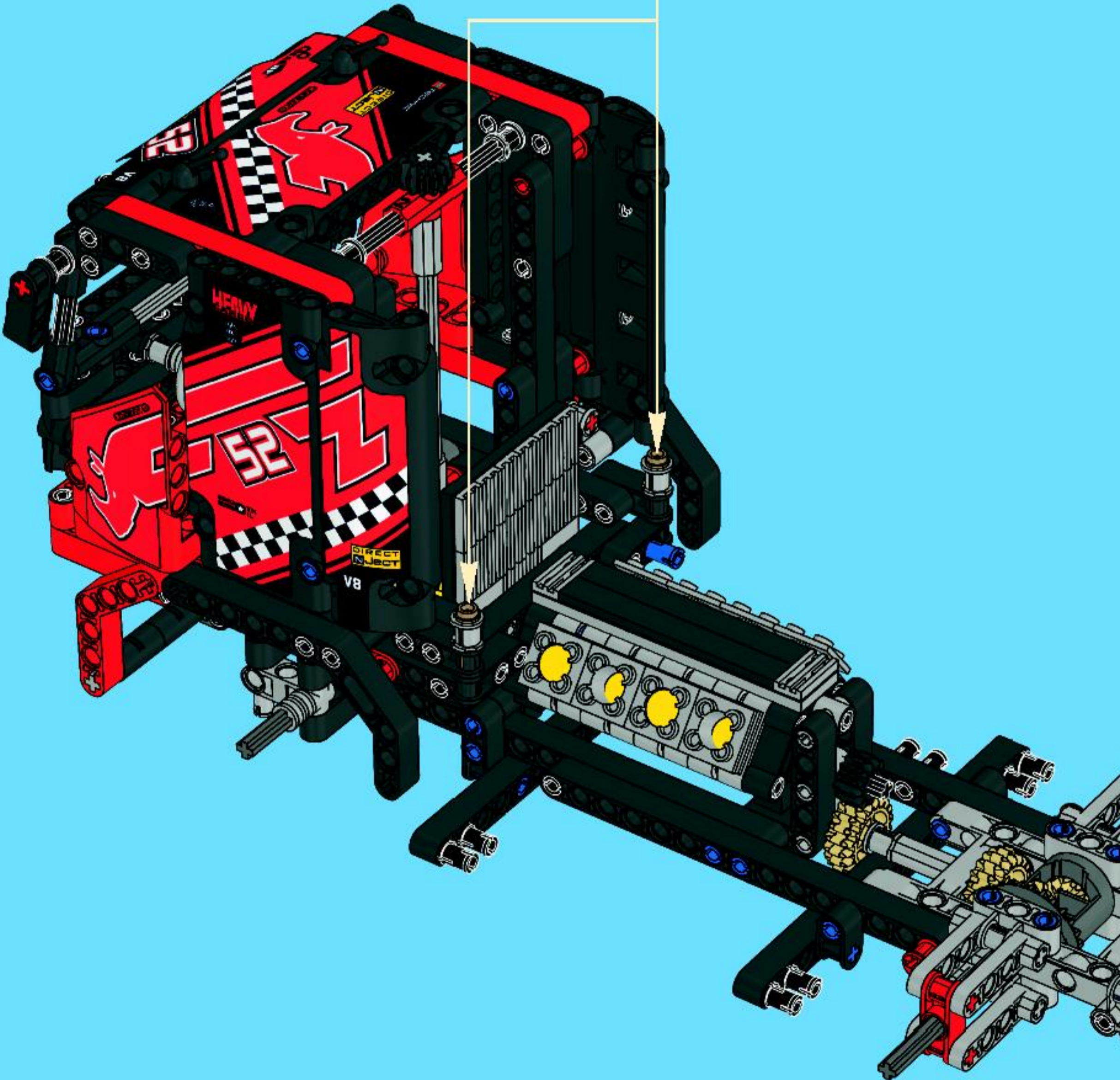



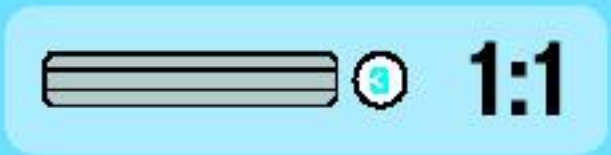
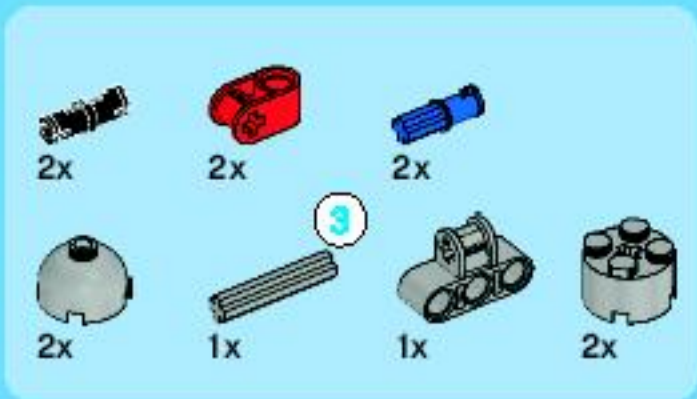

# 65

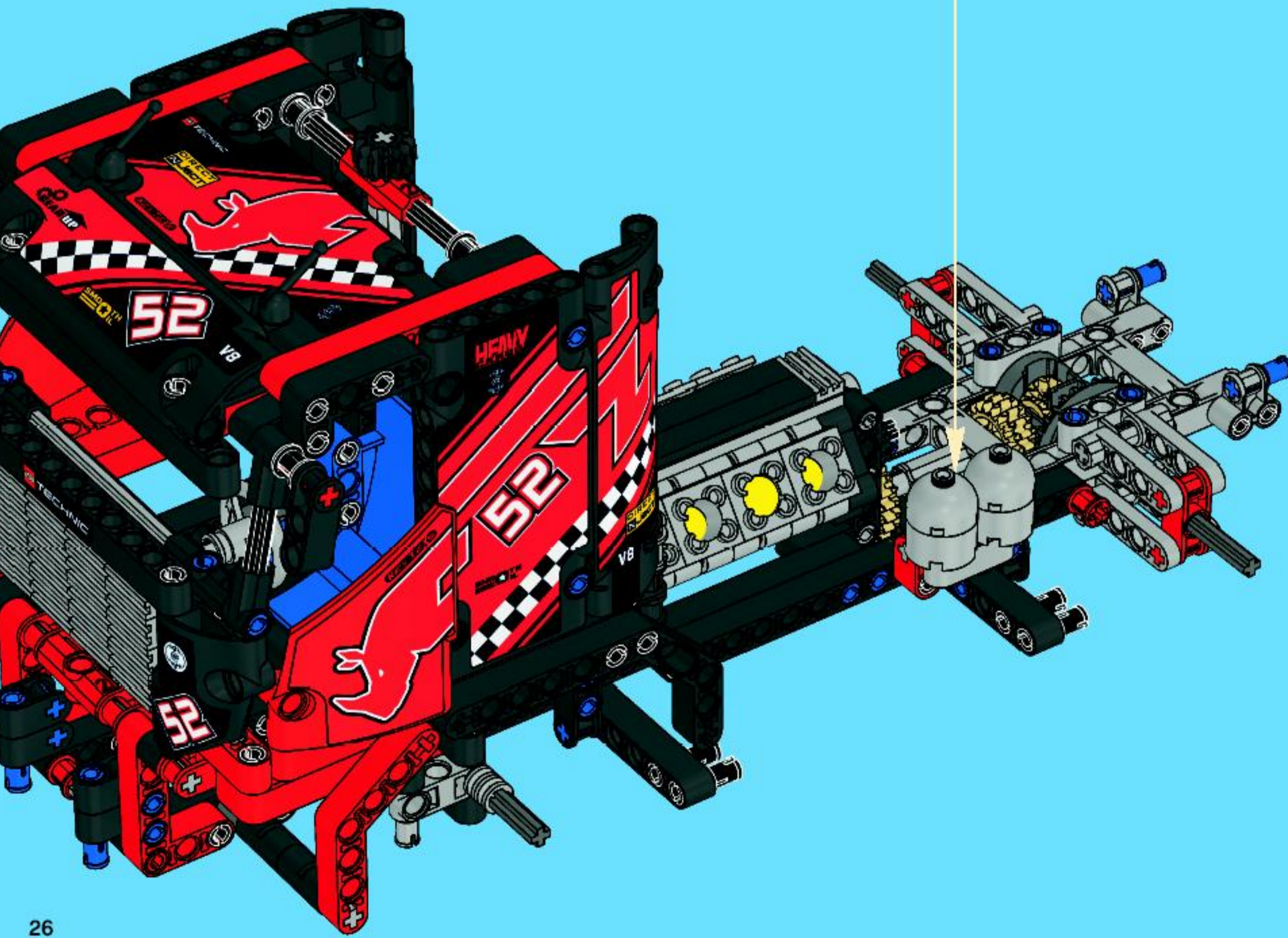
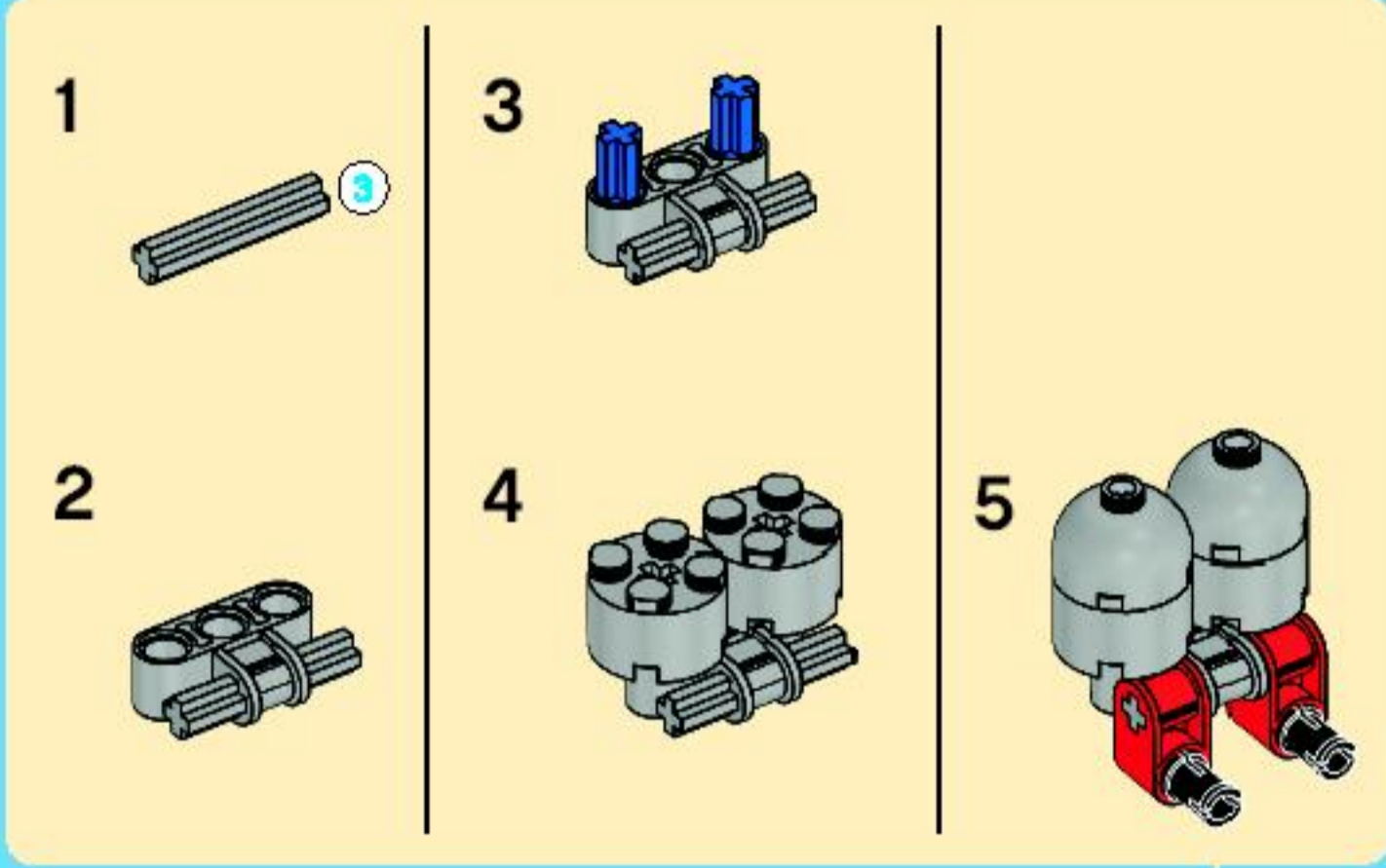



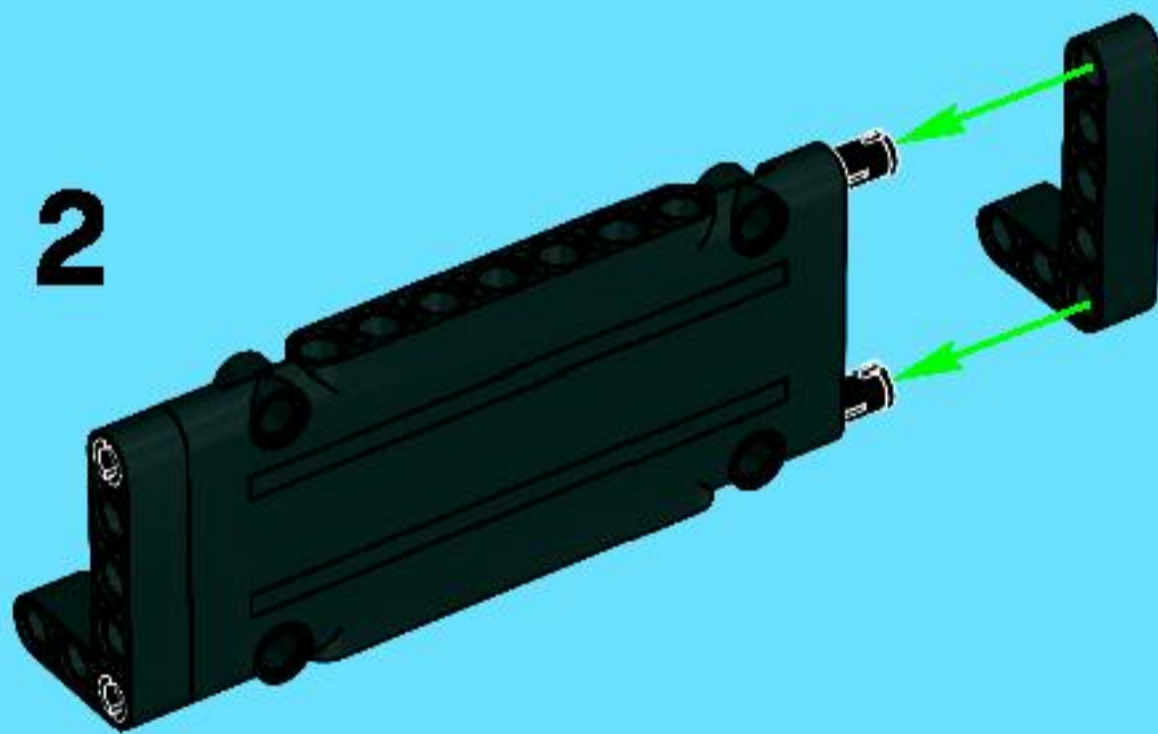
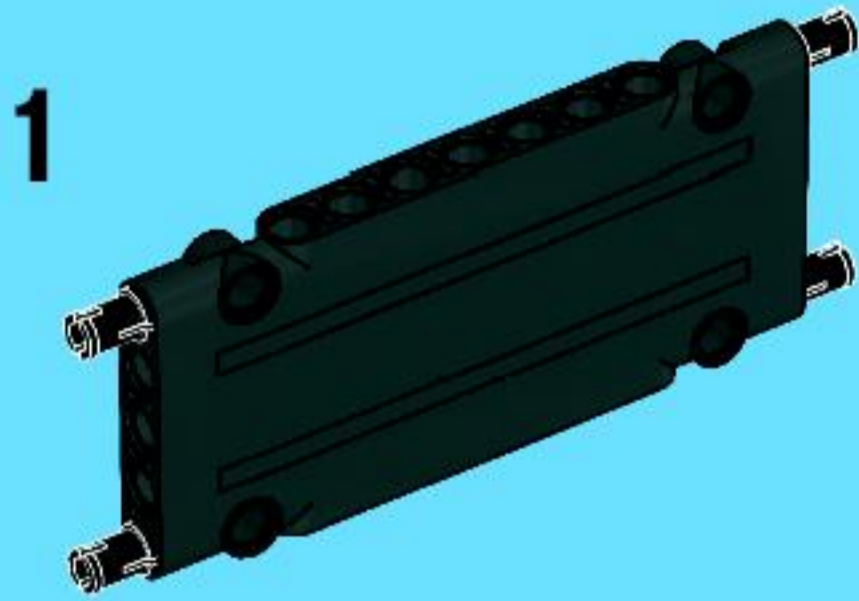
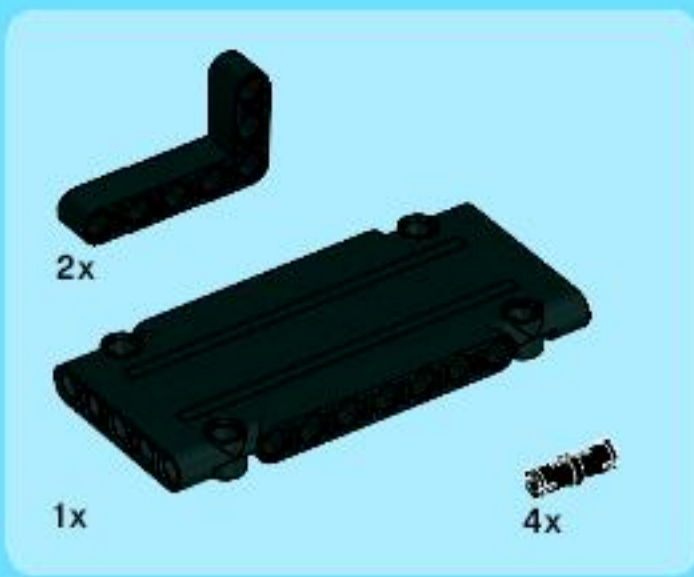



66

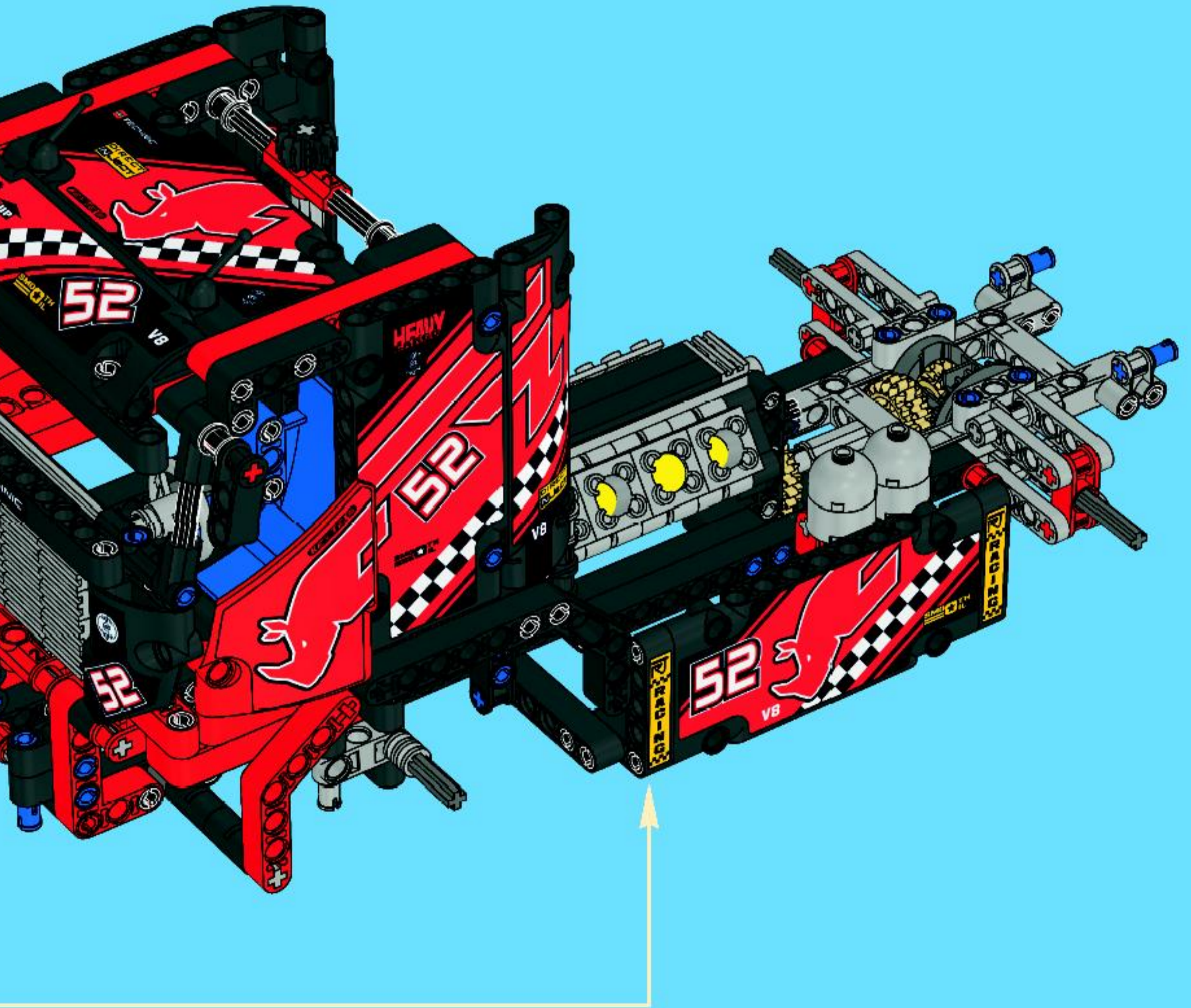





1

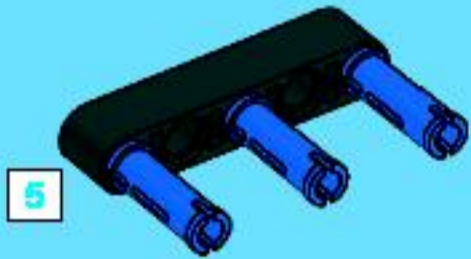

2



3



4



5

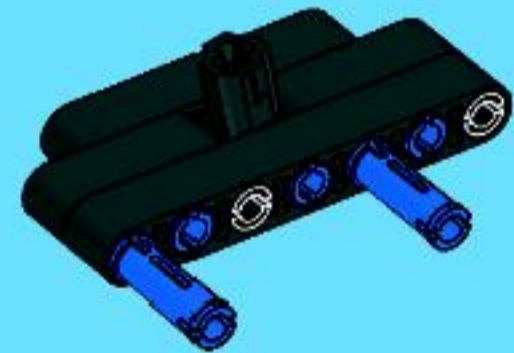

6

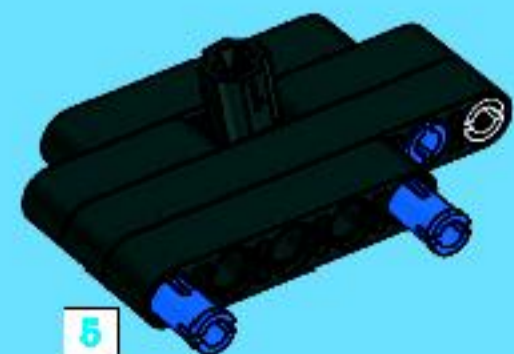





7



8

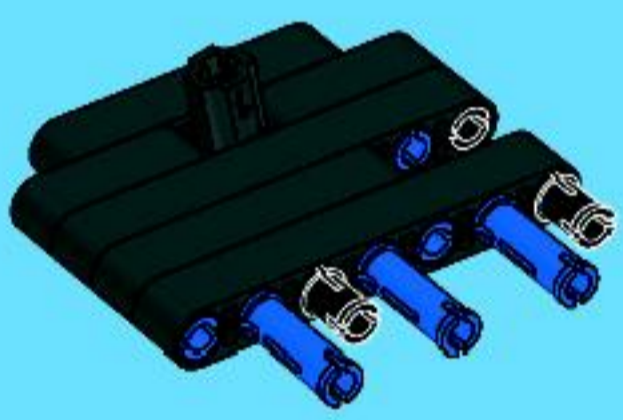

9

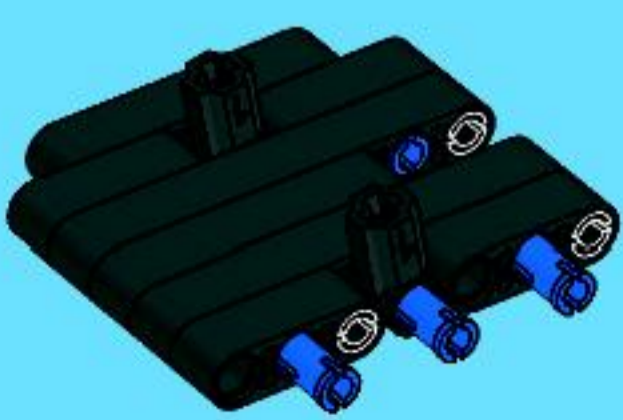

10

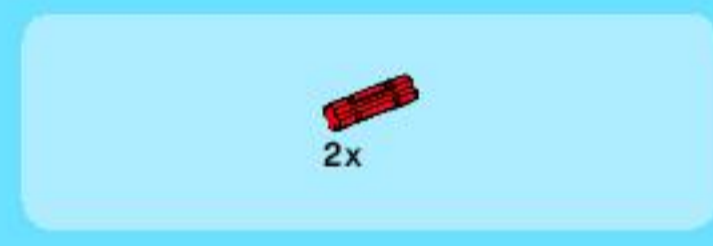
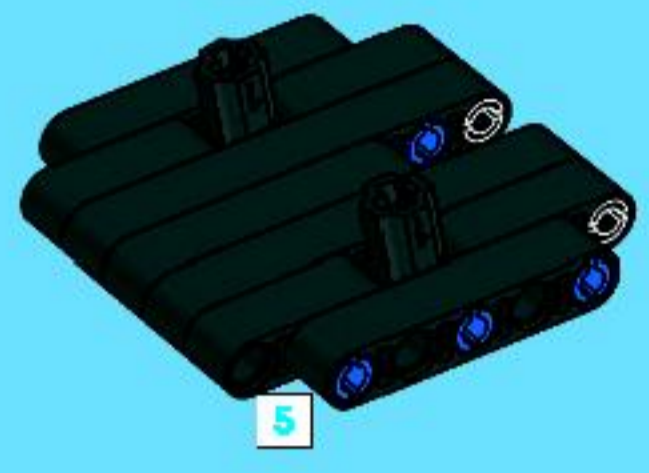

11



12

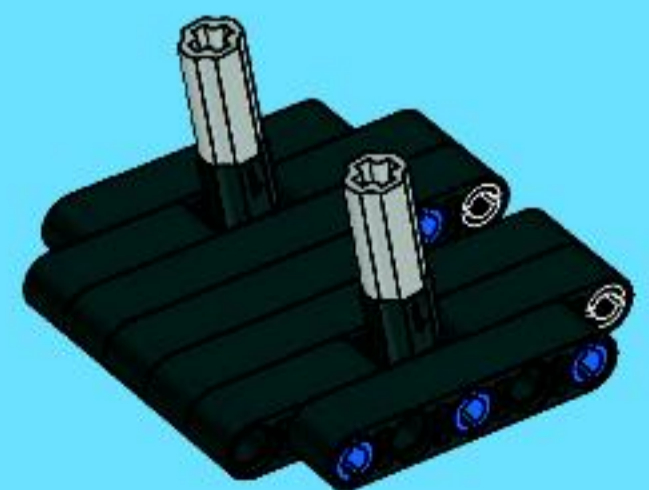





2x

13

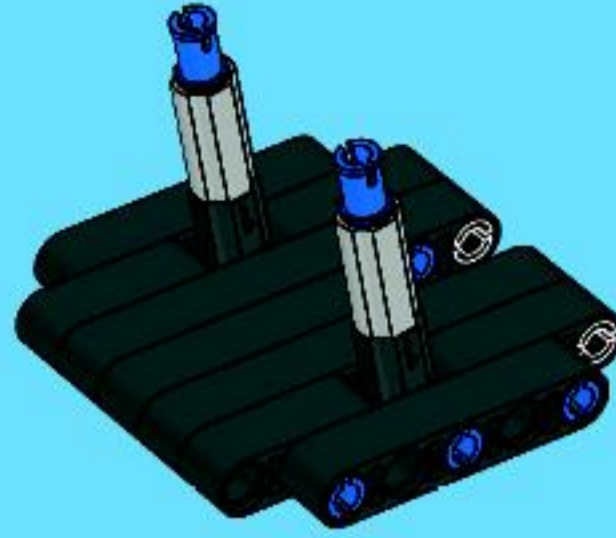

67

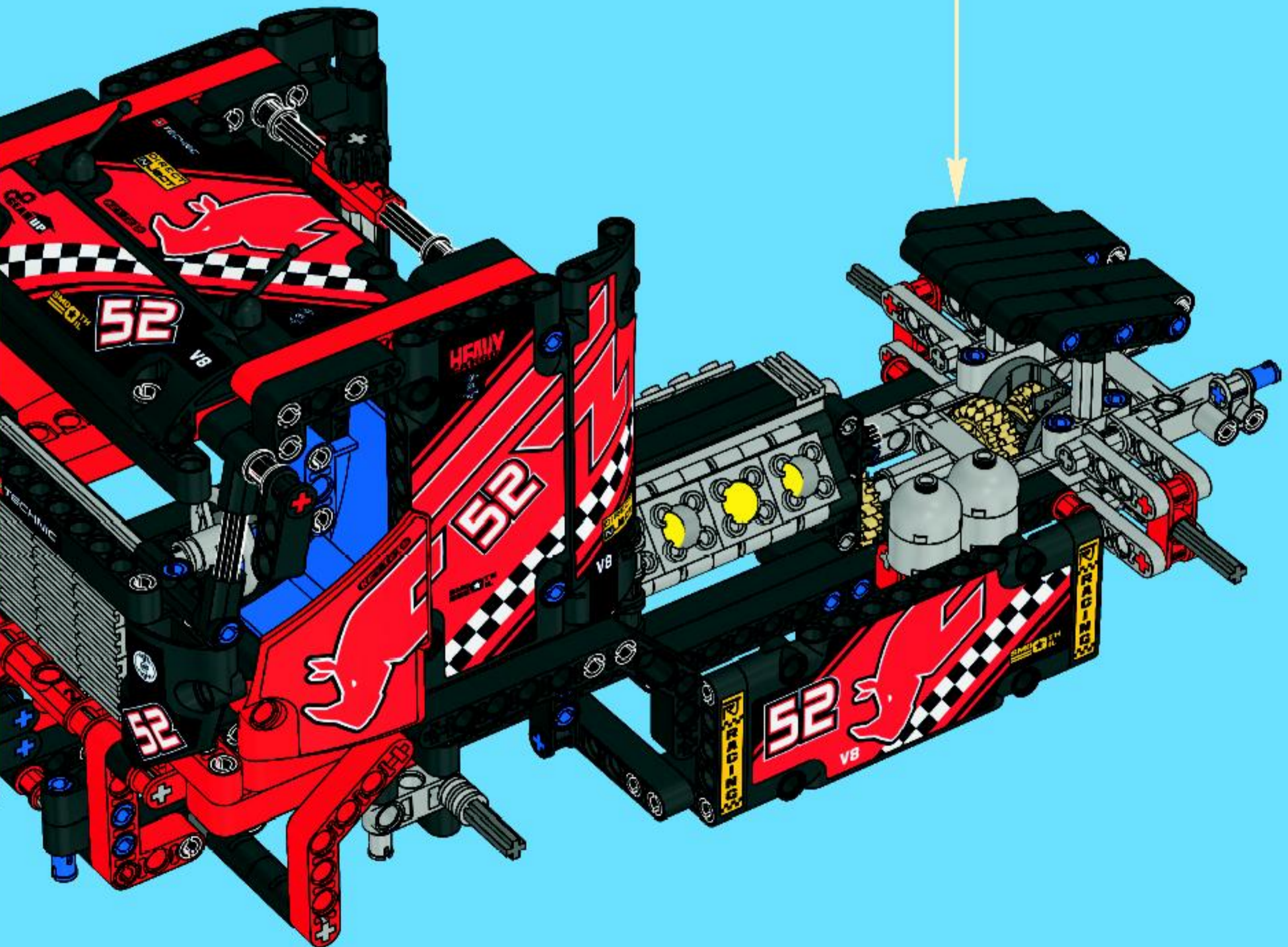





1



2

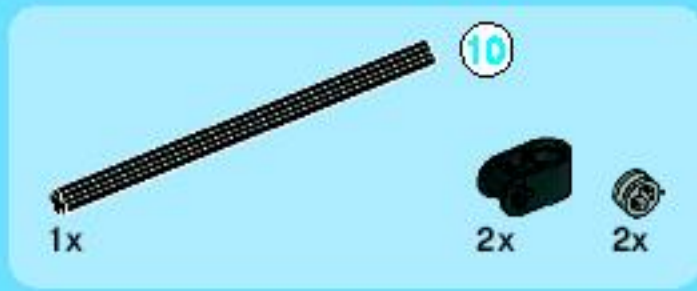
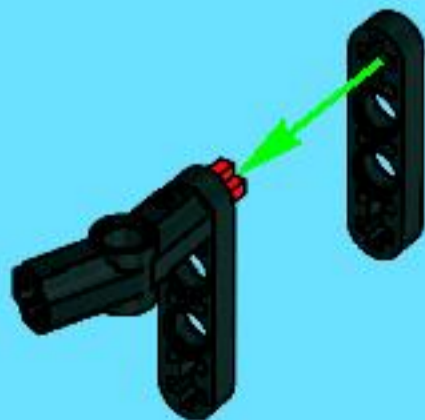

3

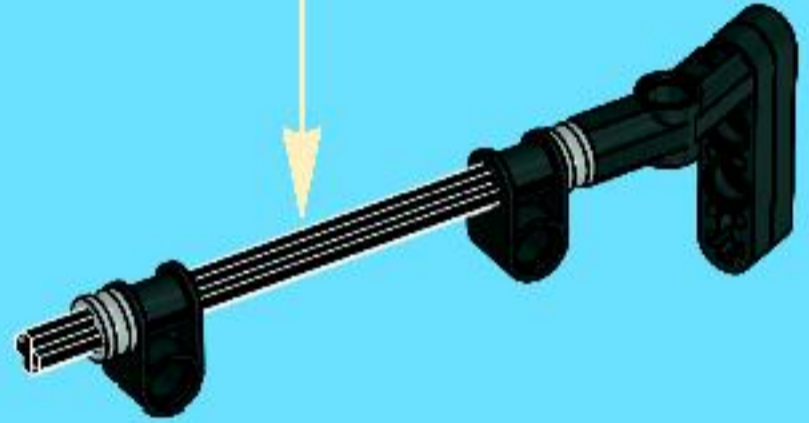

4

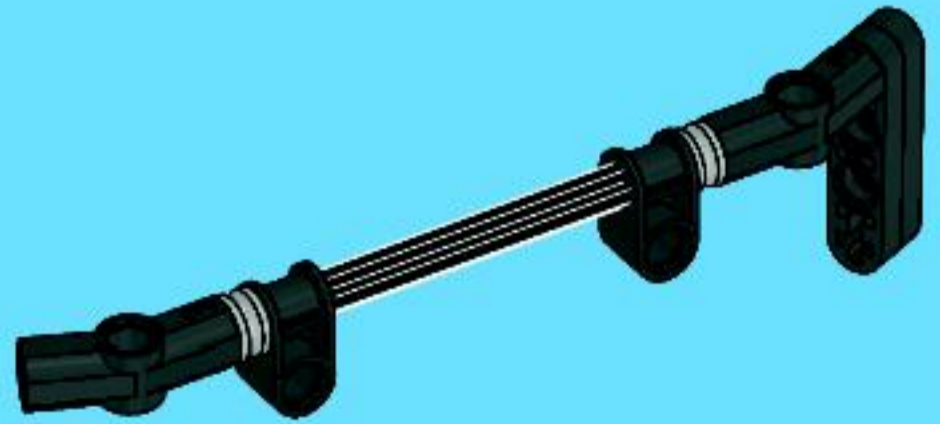



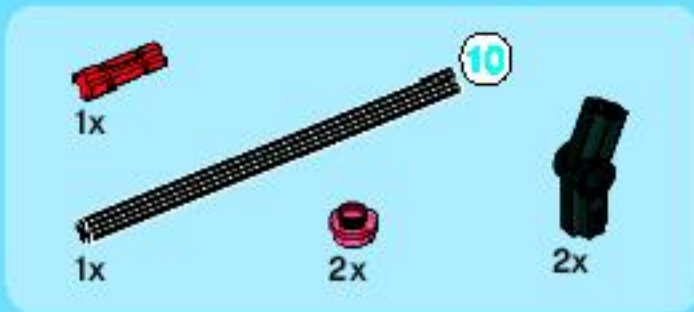

5

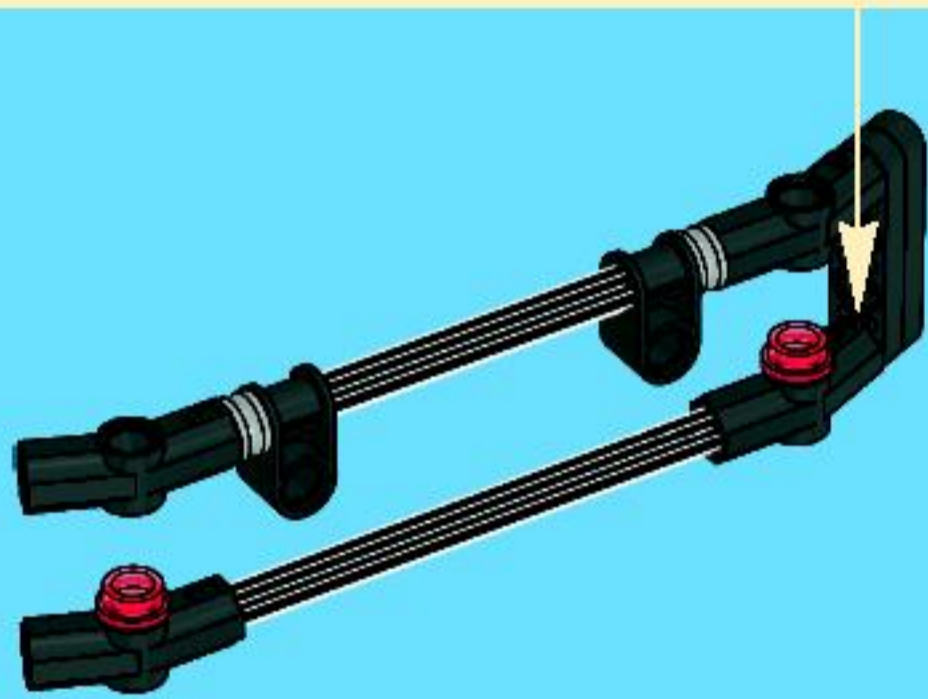
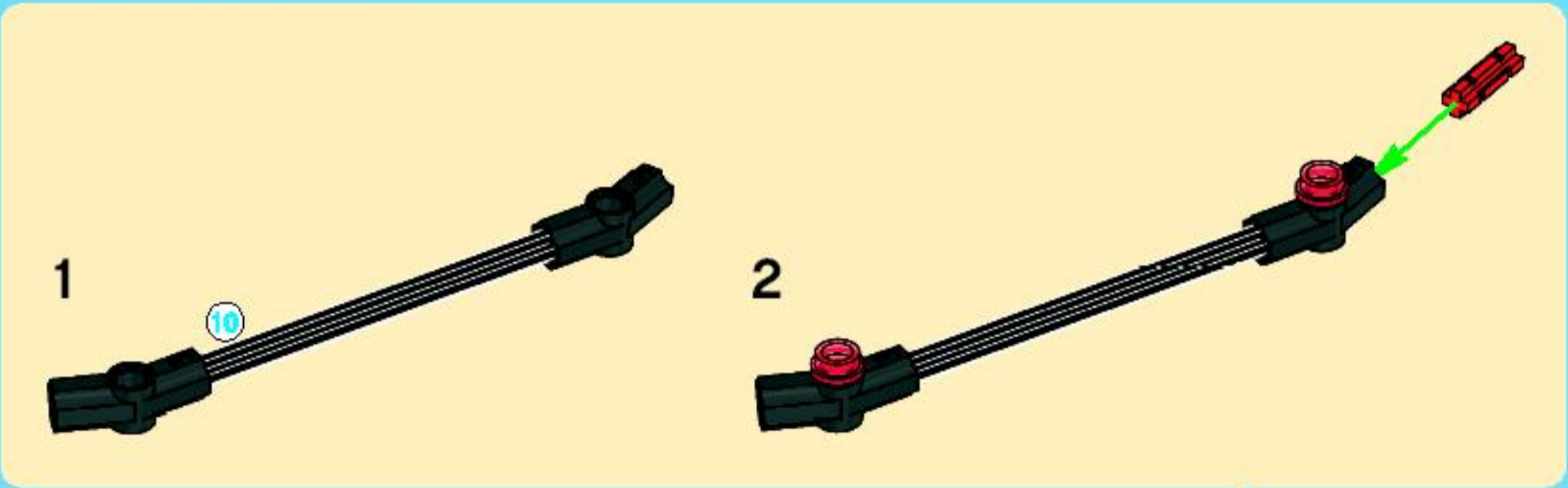

6

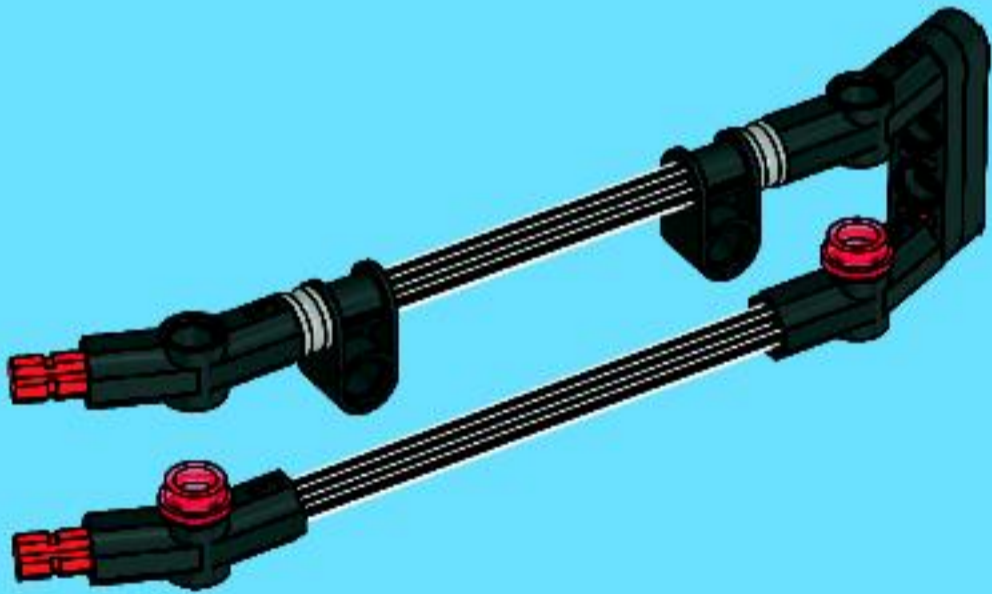

7

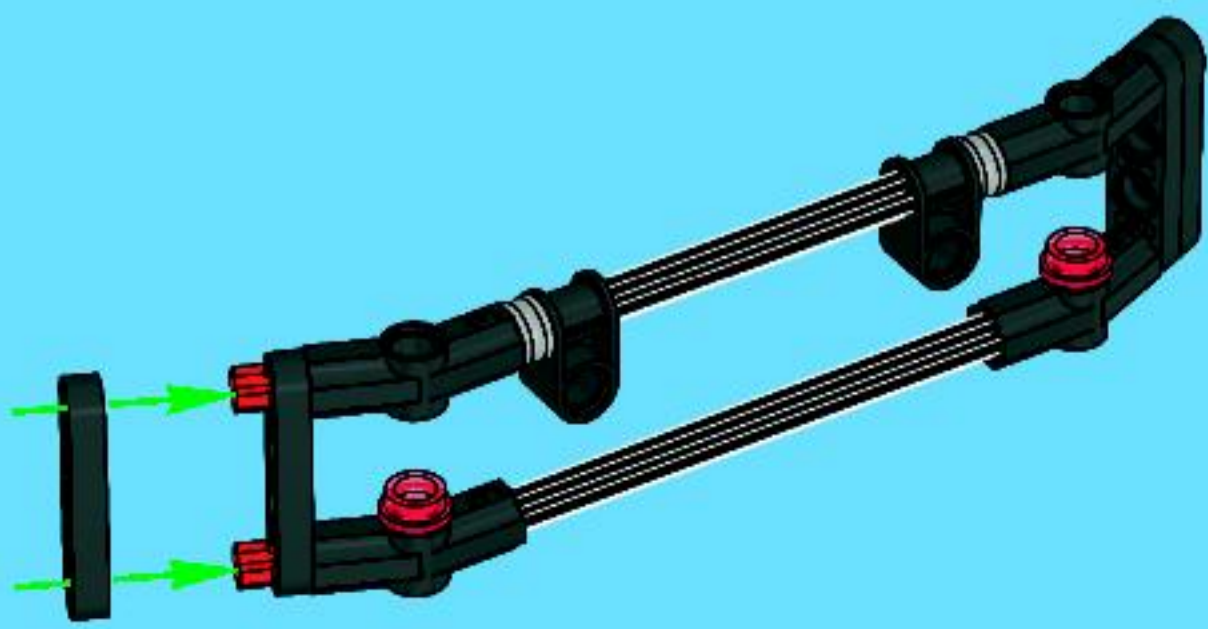



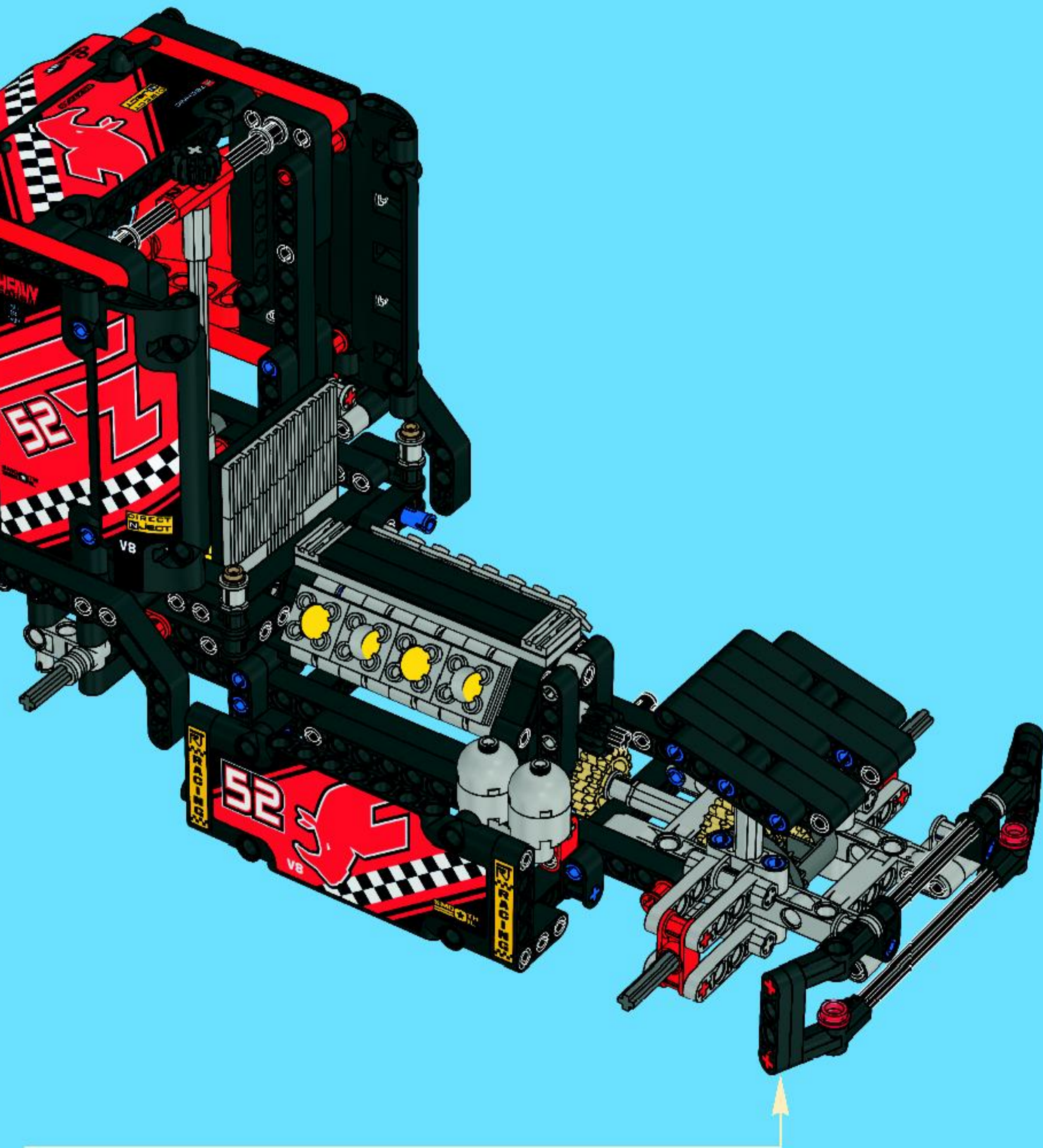



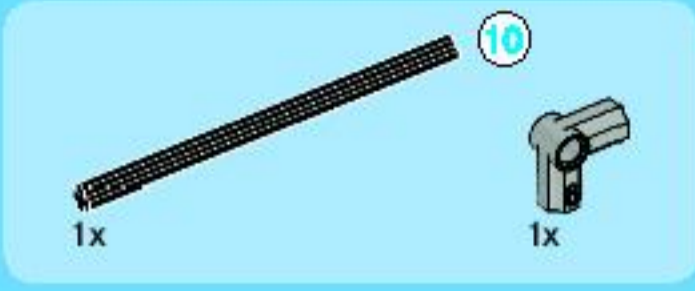
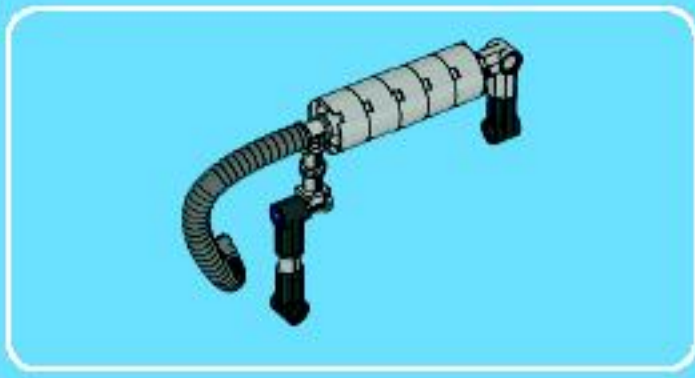

1

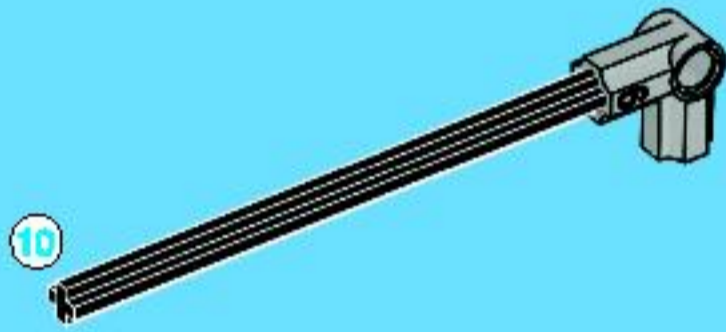

2

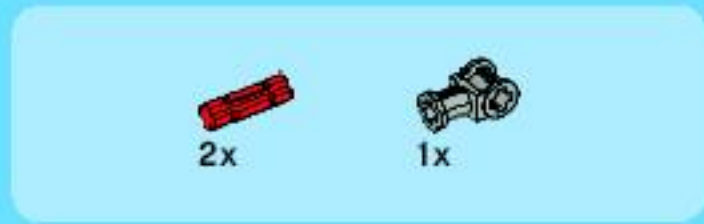
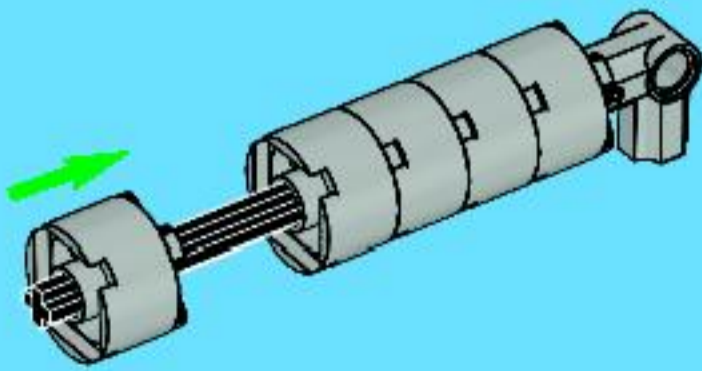

3

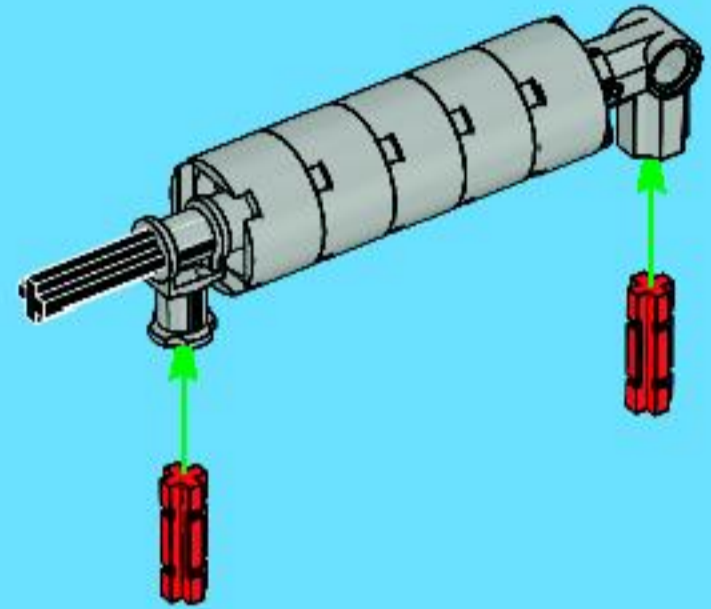

4

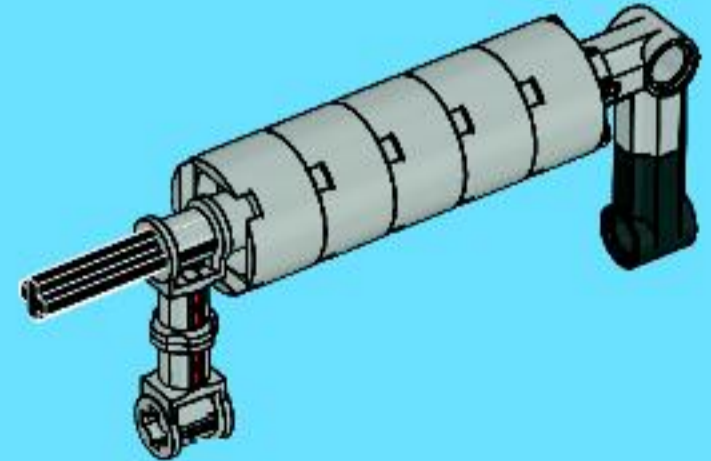





5

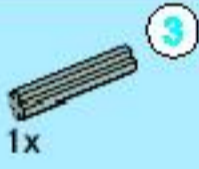
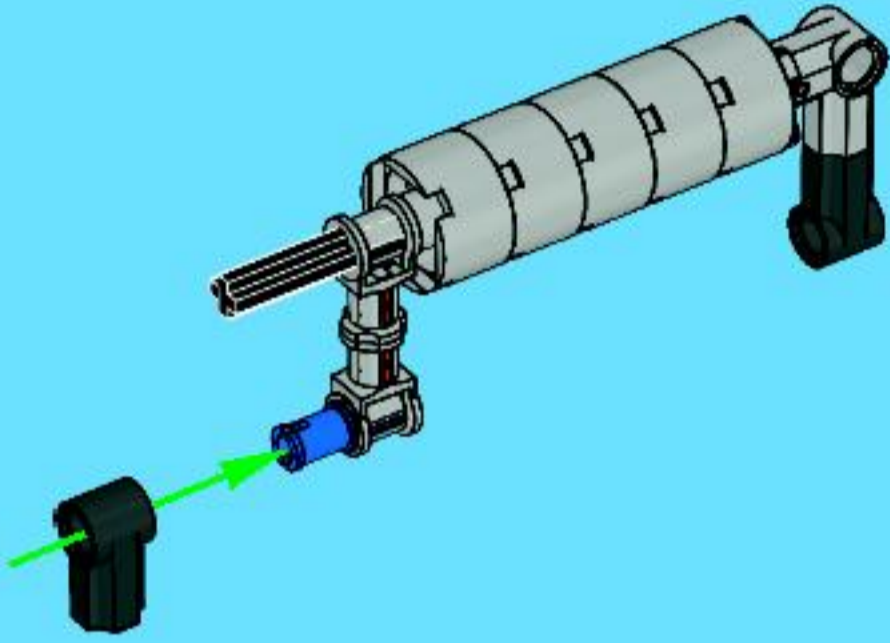

6

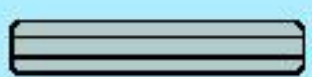
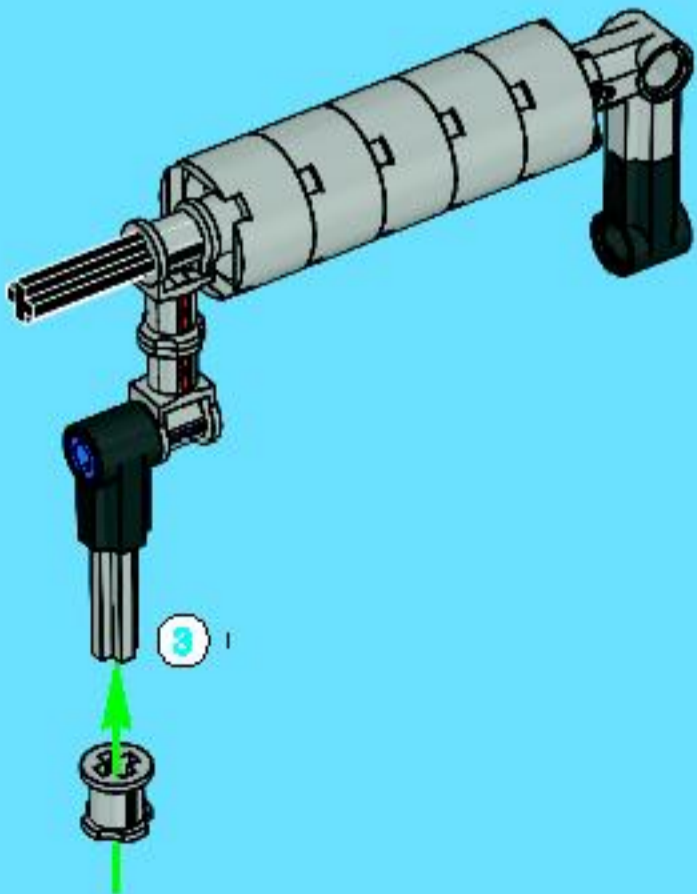

1:1

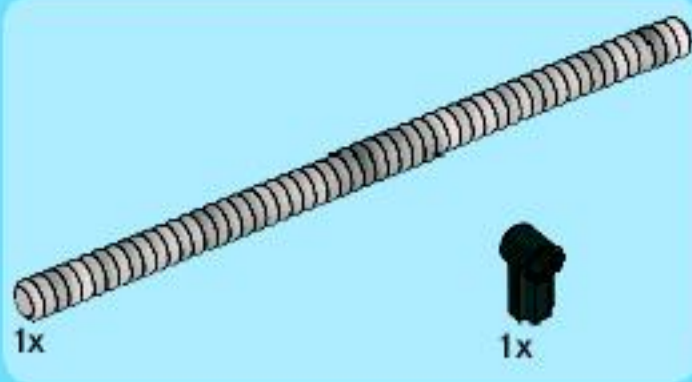

7

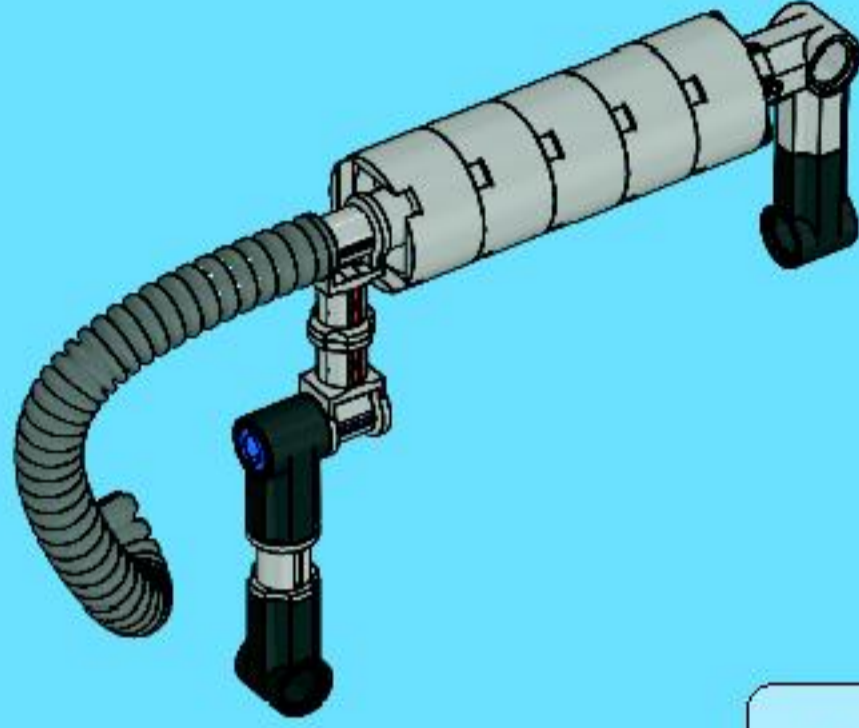

1:1





69

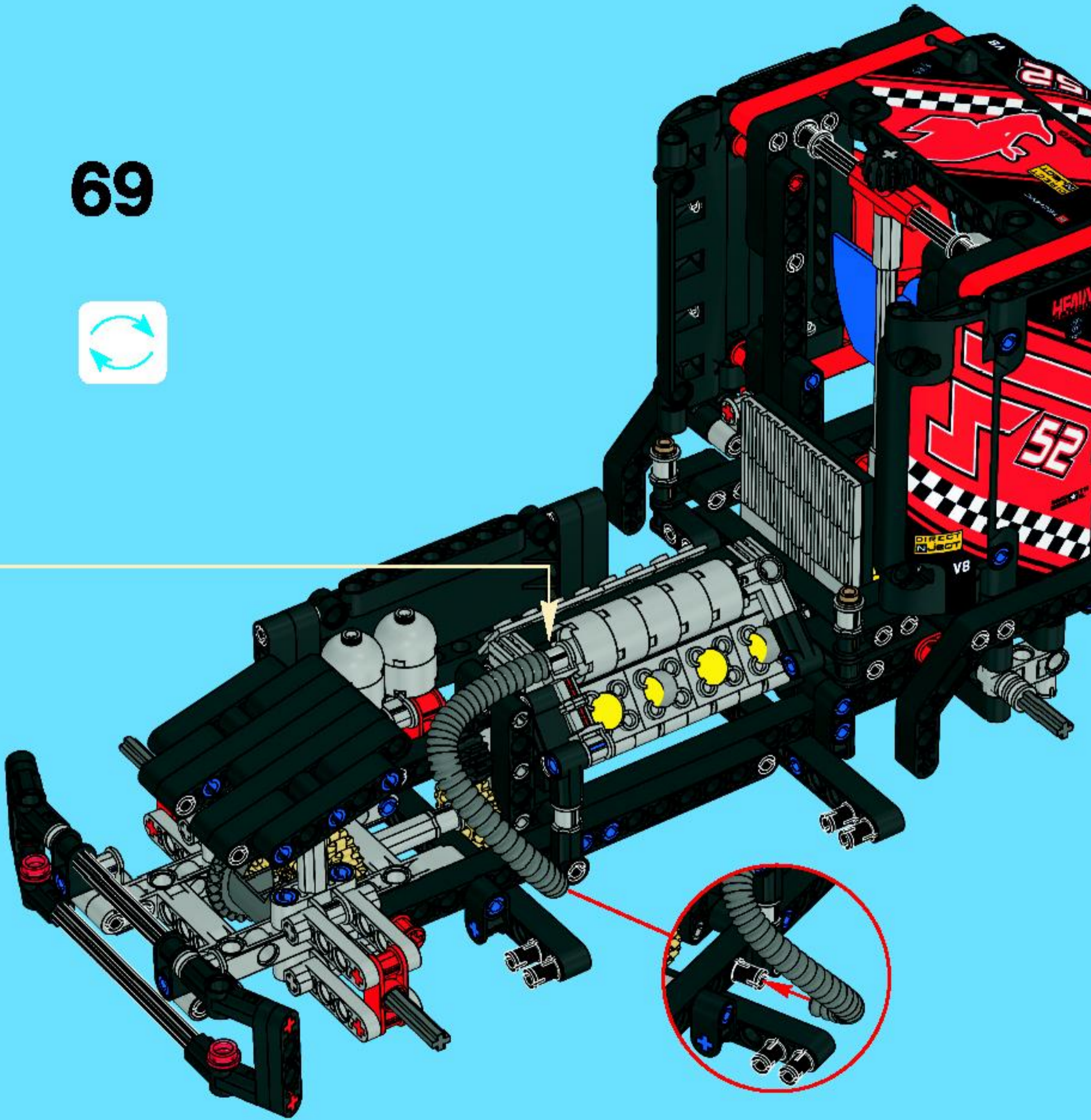



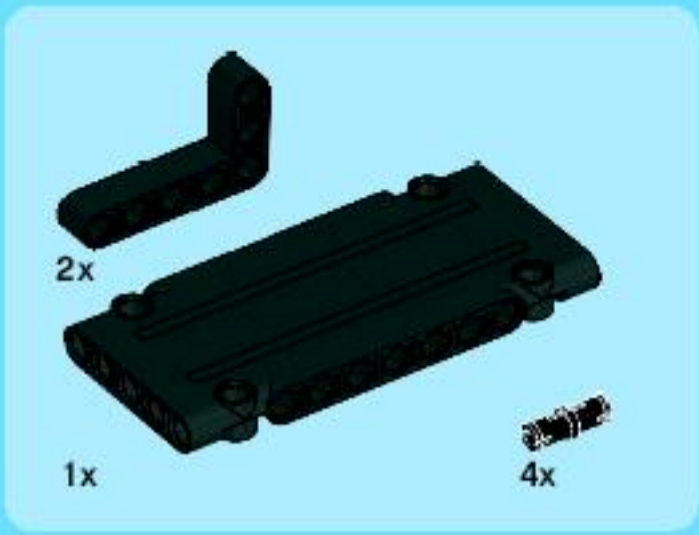

1

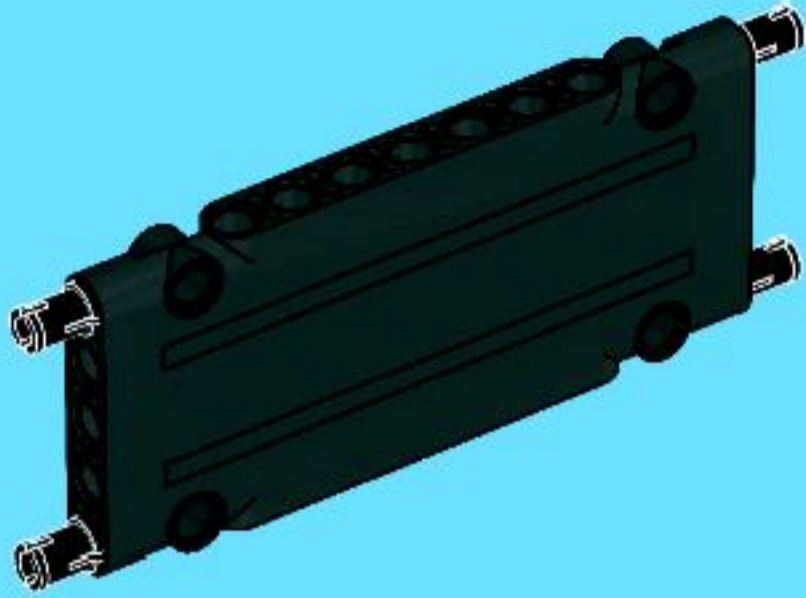

2

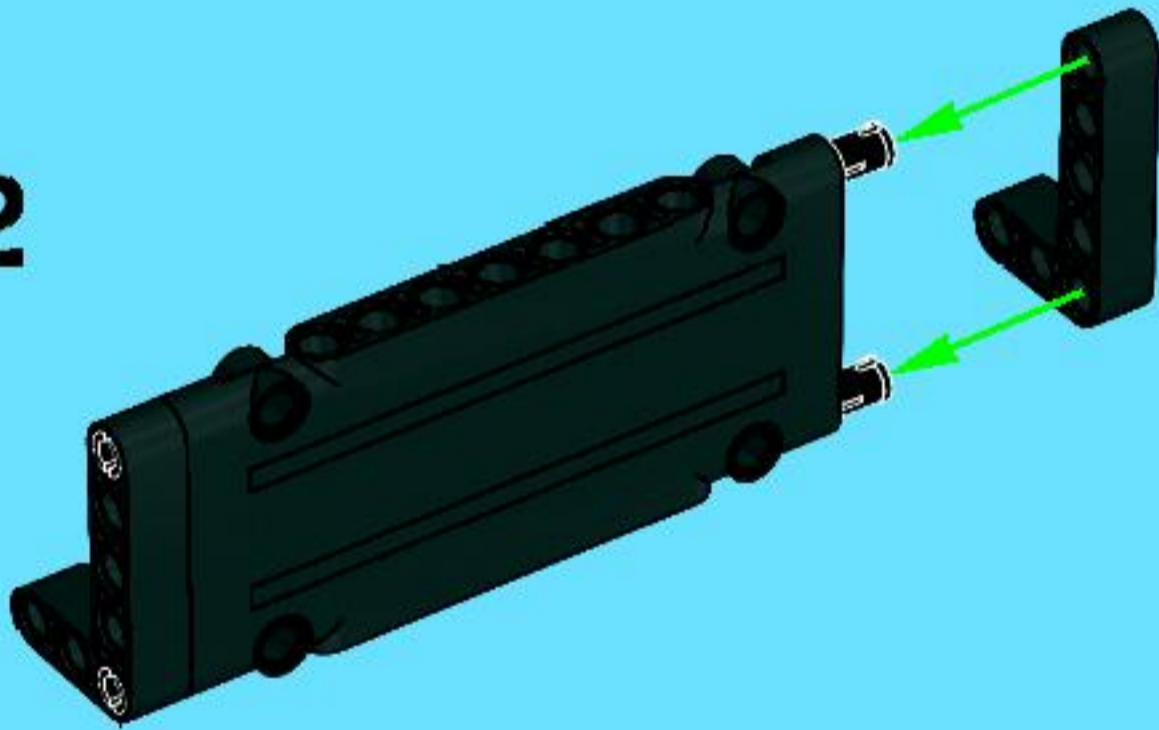

3





70

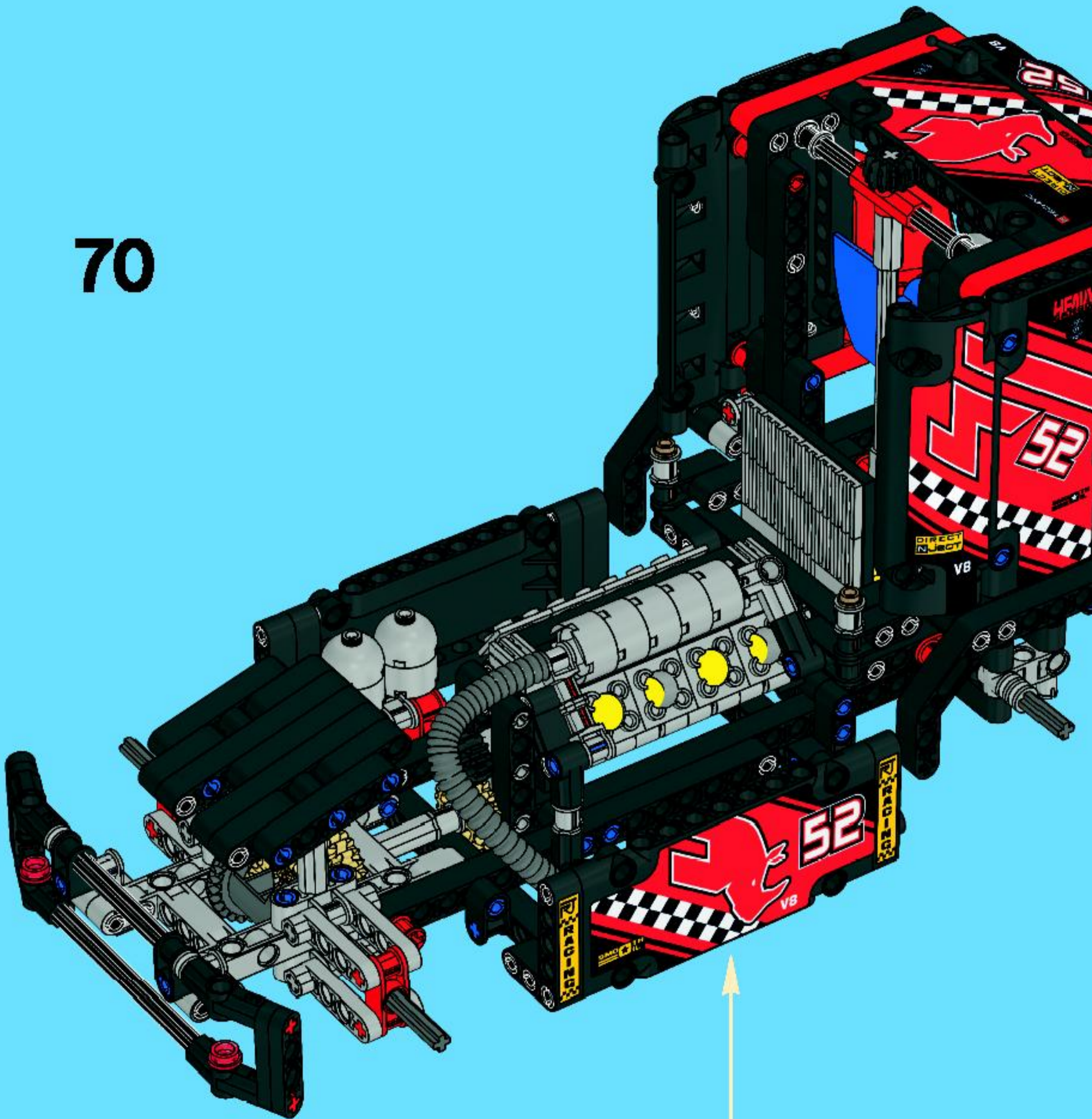



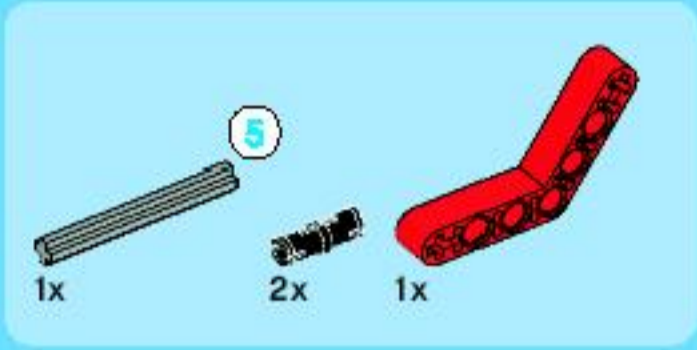
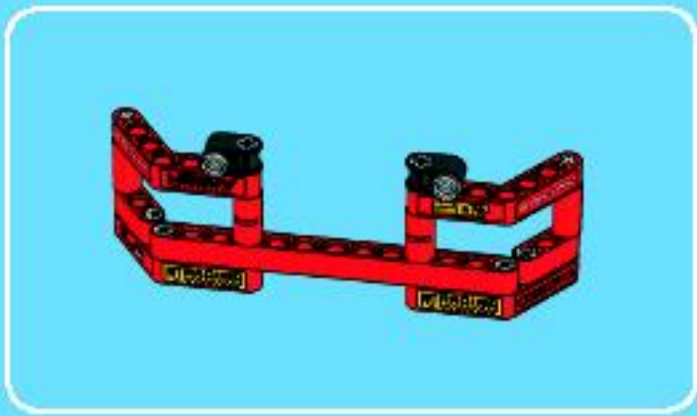

1

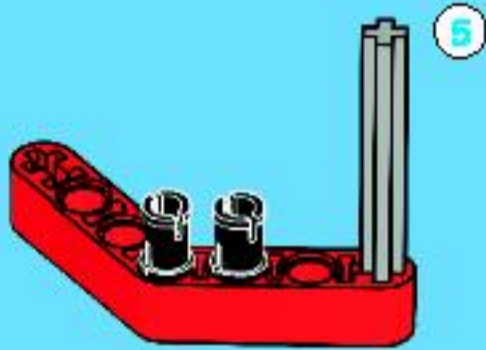

2

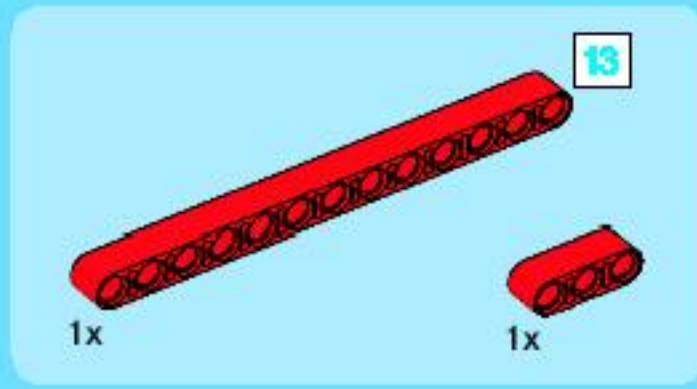
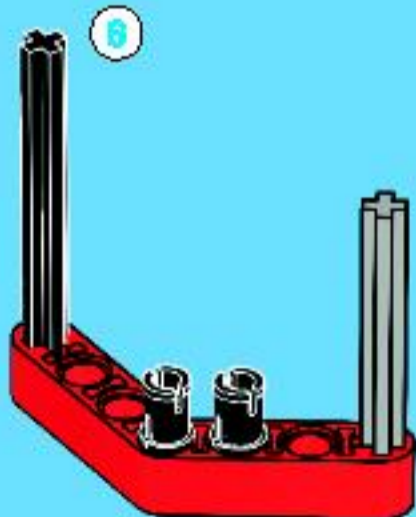

3

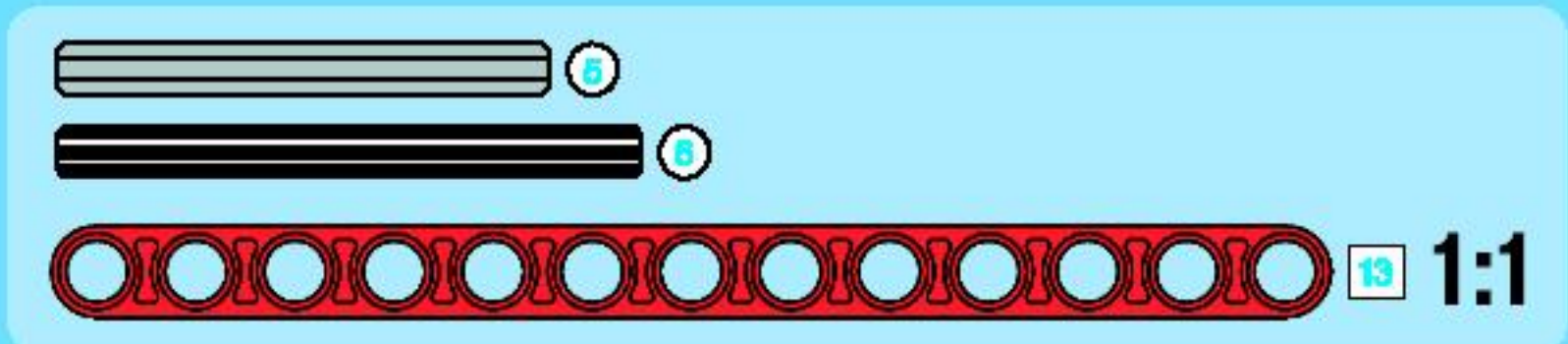
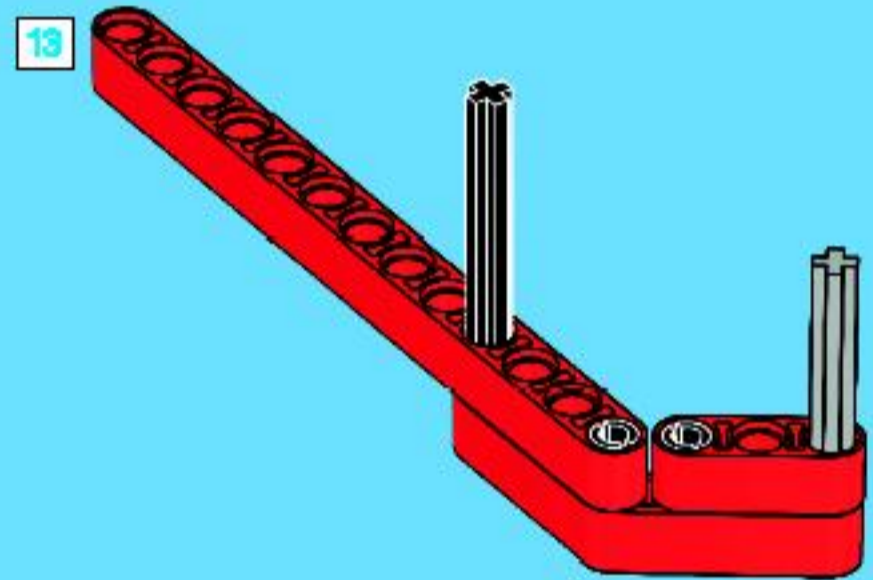



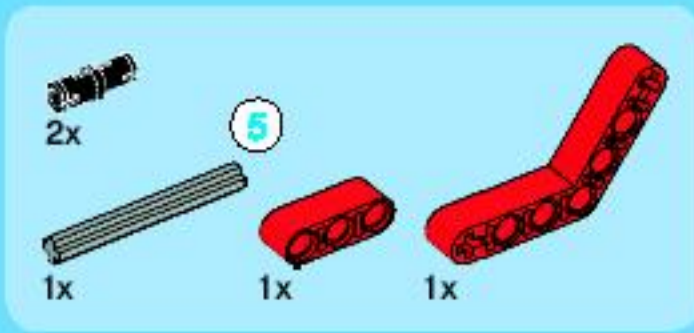

4

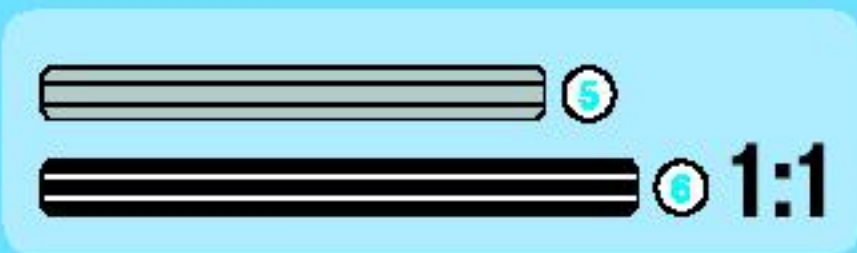
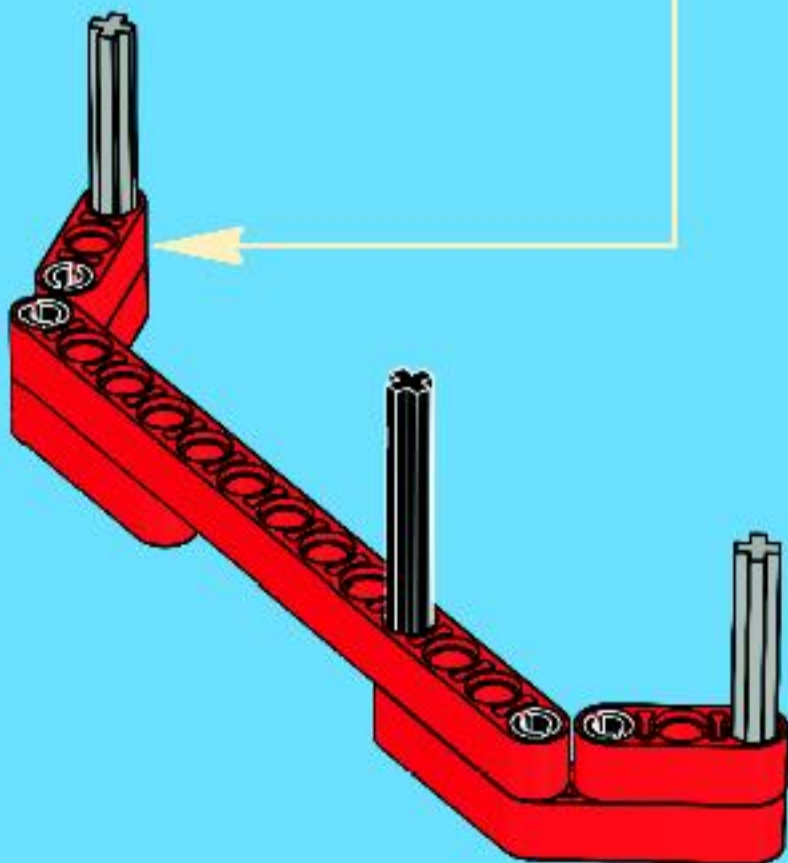
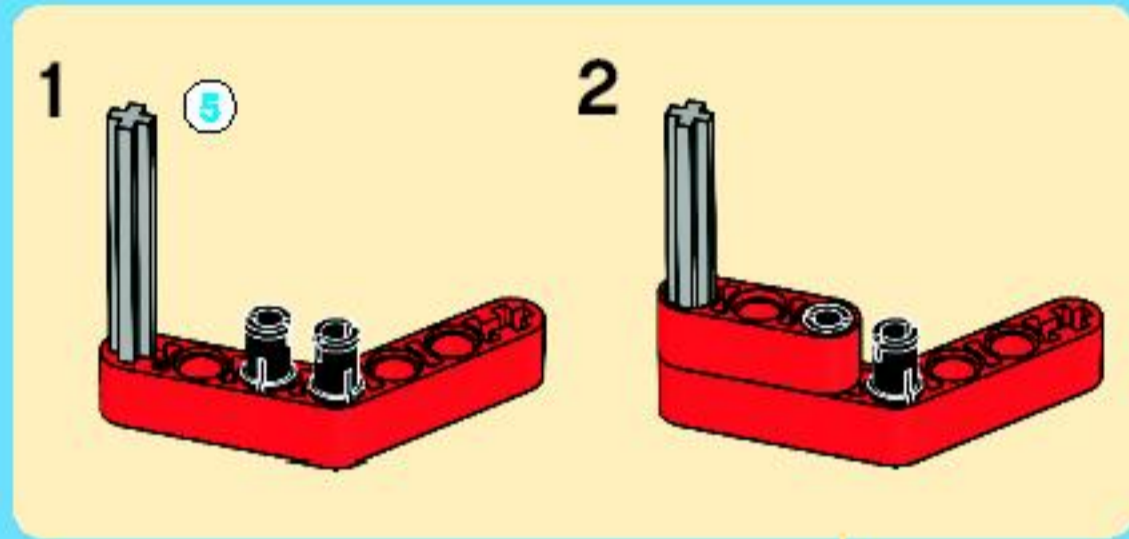

5

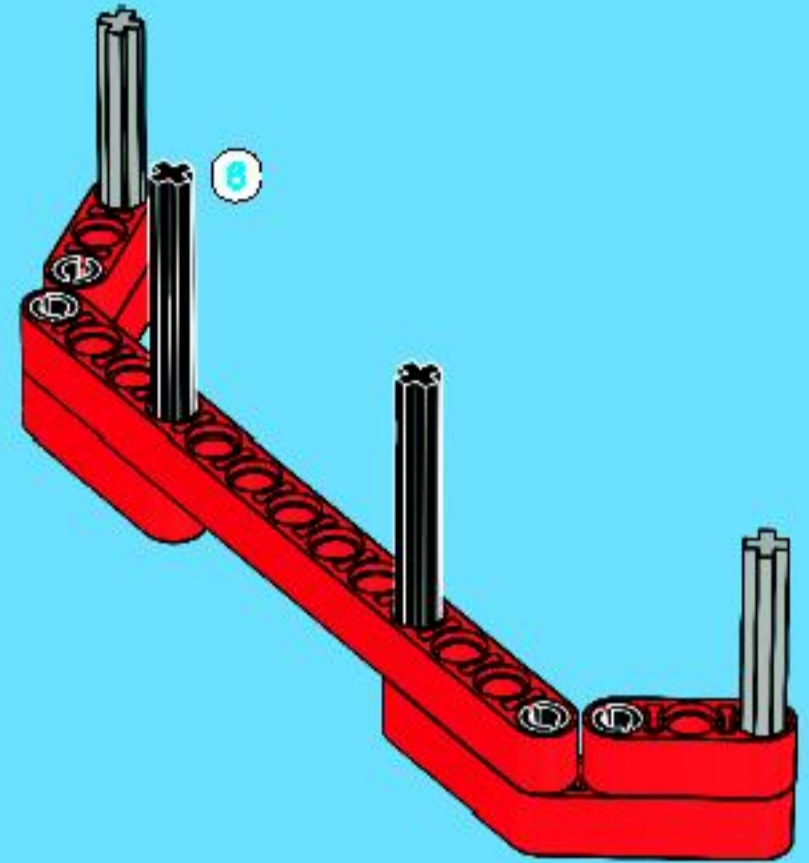

6

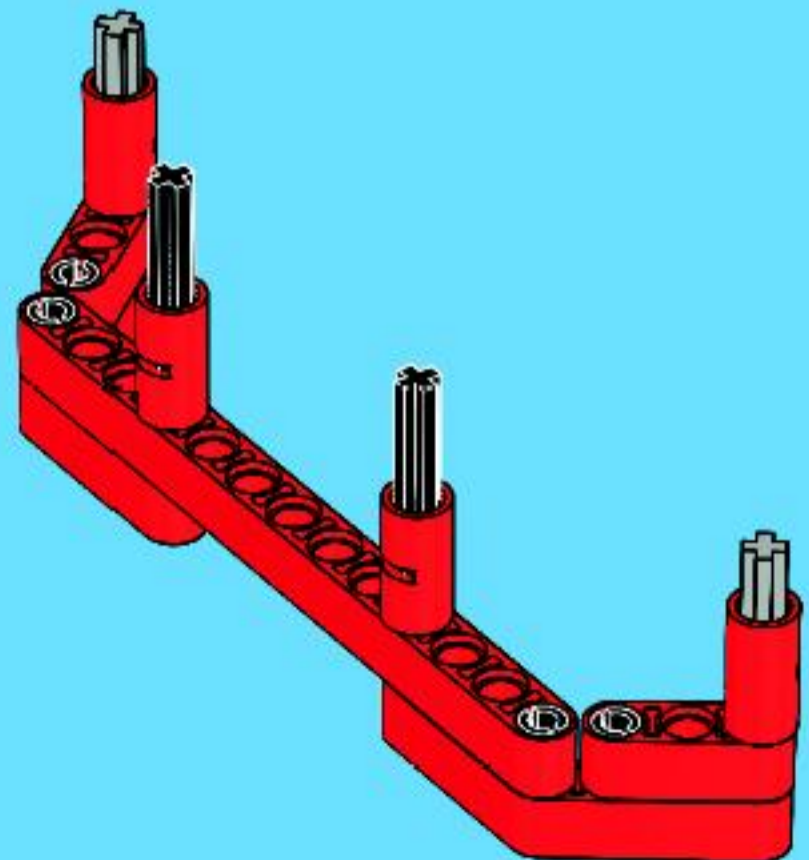





2x

7

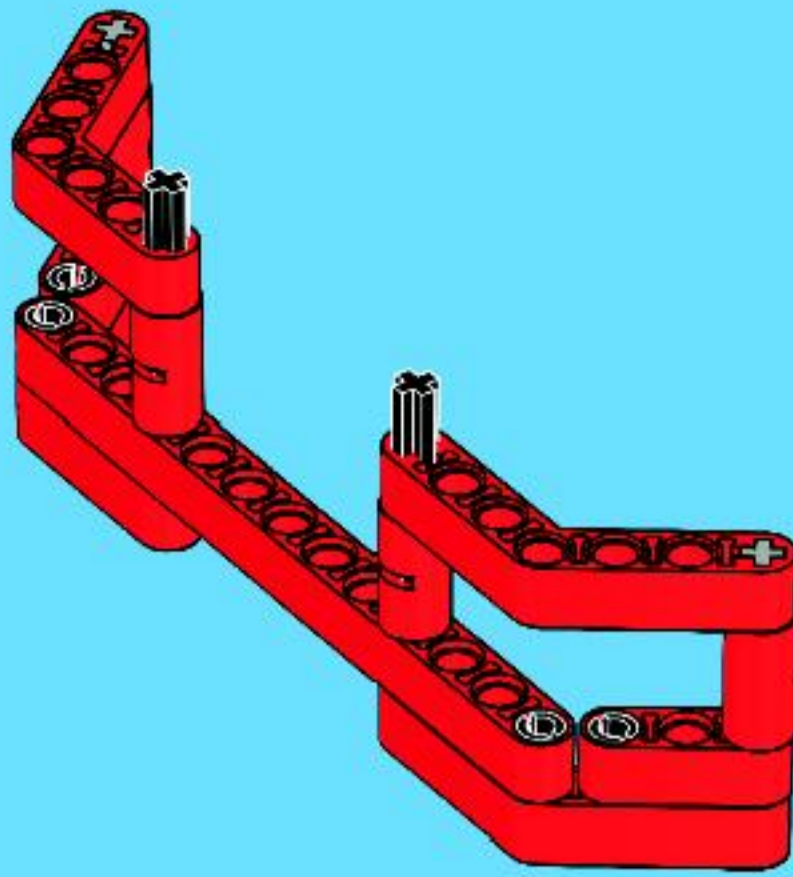

2x



2x

8

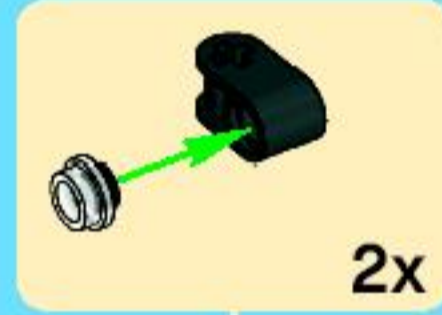

2x

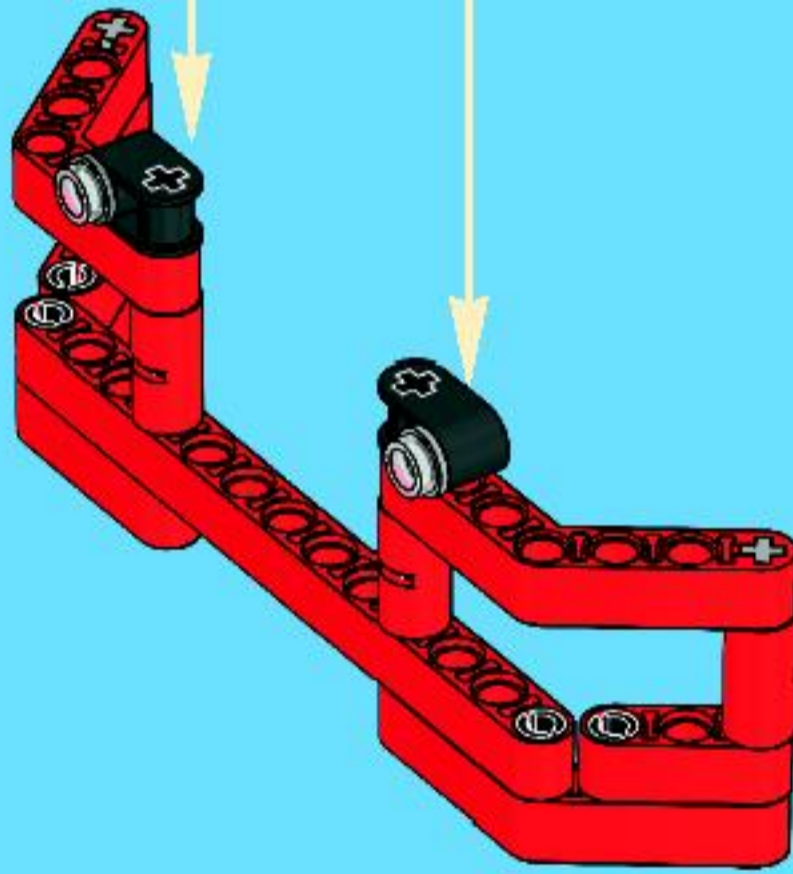

9

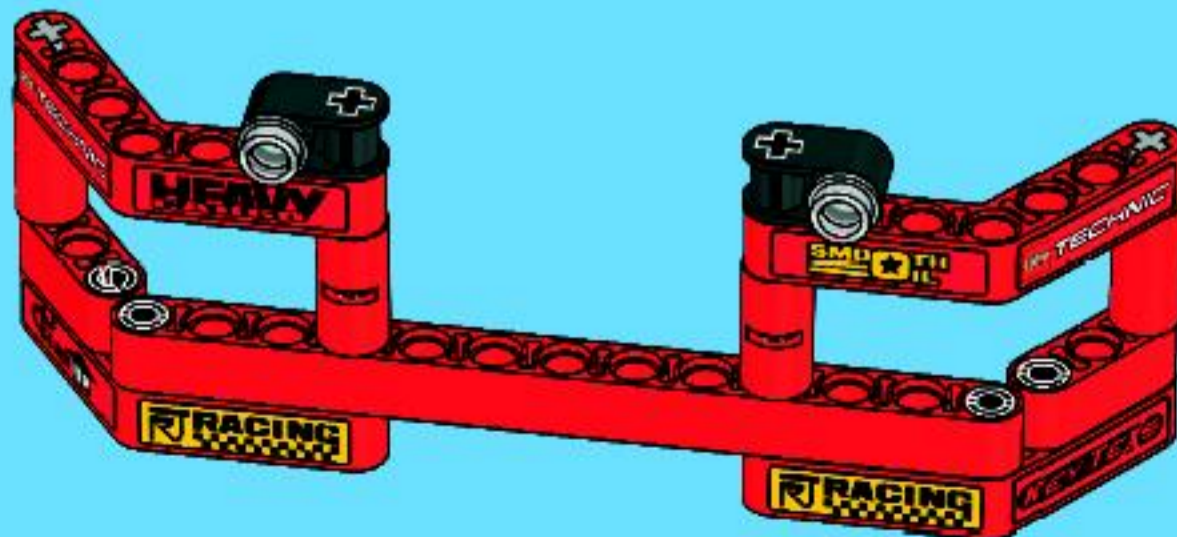



71

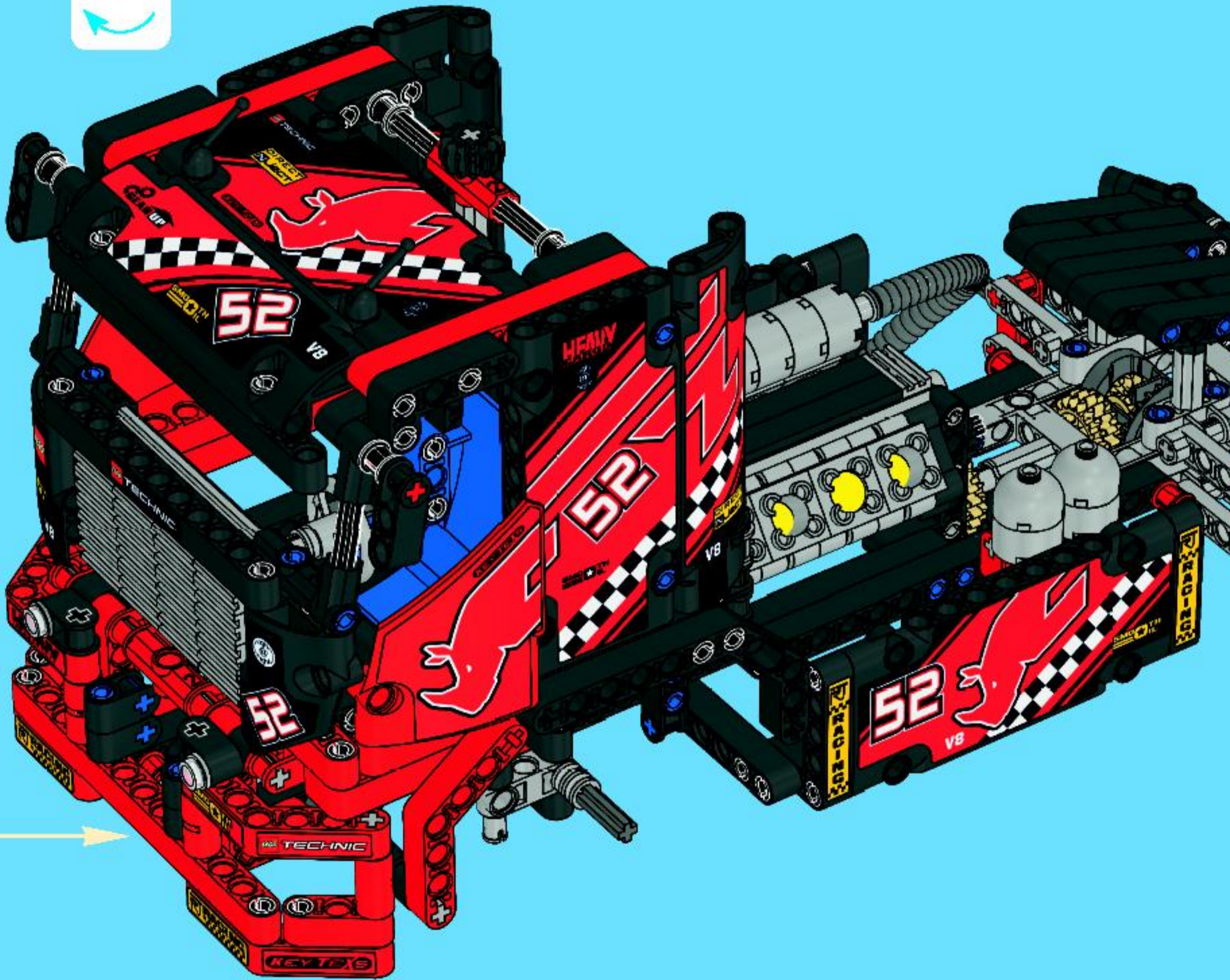



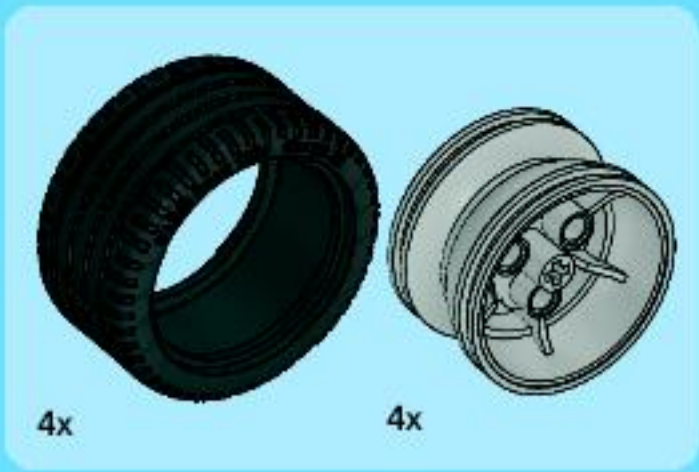

72

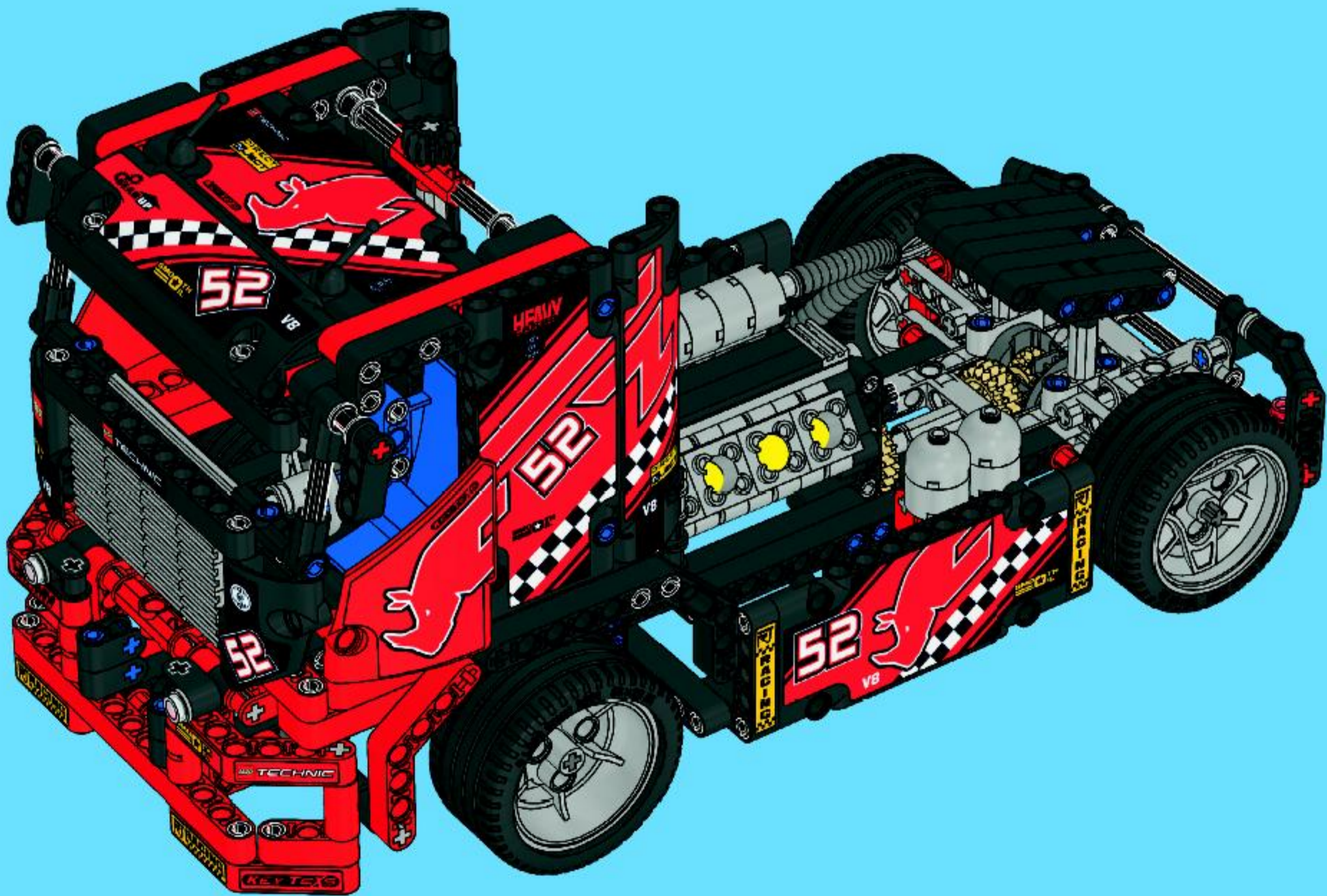









# TECHNIC

Alternative model building instructions only available for download from:

Bauanleitungen für alternative Modelle stehen ausschließlich als Download zur Verfügung unter:

Les instructions de montage du modèle alternatif sont uniquement disponibles sur Internet dans la rubrique « Montage » du site:

Las instrucciones de construcción del modelo alternativo sólo pueden obtenerse a través de:

Instruções de construção do modelo alternativo disponíveis para descarregar apenas em:

Másféle modellépítési útmutatókat csak az alábbi helyről tölthetsz le:

**Technic.LEGO.com.**











# WIN!

Go to [www.nielsen.com/LEGO](http://www.nielsen.com/LEGO) to fill out a survey for a chance to win a cool LEGO® Product. No purchase necessary. Open to all residents where not prohibited.



## [www.nielsen.com/LEGO](http://www.nielsen.com/LEGO)

### GEWINNE!

Nimm an der Umfrage auf [www.nielsen.com/LEGO](http://www.nielsen.com/LEGO) teil und hab die Chance ein cooles LEGO® Produkt zu gewinnen!  
Die Teilnahme am Gewinnspiel führt zu keinerlei Kaufverpflichtungen. Teilnahme in allen nicht aus geschlossenen Ländern möglich.

### WIN!

Ga naar [www.nielsen.com/LEGO](http://www.nielsen.com/LEGO), vul een enquêteformulier in en maak kans op een cool LEGO® product.  
Geen aankoopverplichting. Iedereen mag deelnemen, uitgezonderd ingezetenen van landen waar een enquêteverbod geldt.

### GAGNE!

Visite [www.nielsen.com/LEGO](http://www.nielsen.com/LEGO) pour répondre à un questionnaire et avoir une chance de gagner un produit LEGO® très cool!  
Aucune obligation d'achat. Ouvert à tous les résidents des pays autorisés.

### 当てよう!

[www.nielsen.com/LEGO](http://www.nielsen.com/LEGO)にアクセスして、アンケートにご記入ください。当選者にはレゴ製品を差し上げます。  
お買い上げの必要はありません。  
禁止されていない限り、すべての情報にご利用いただけます。