

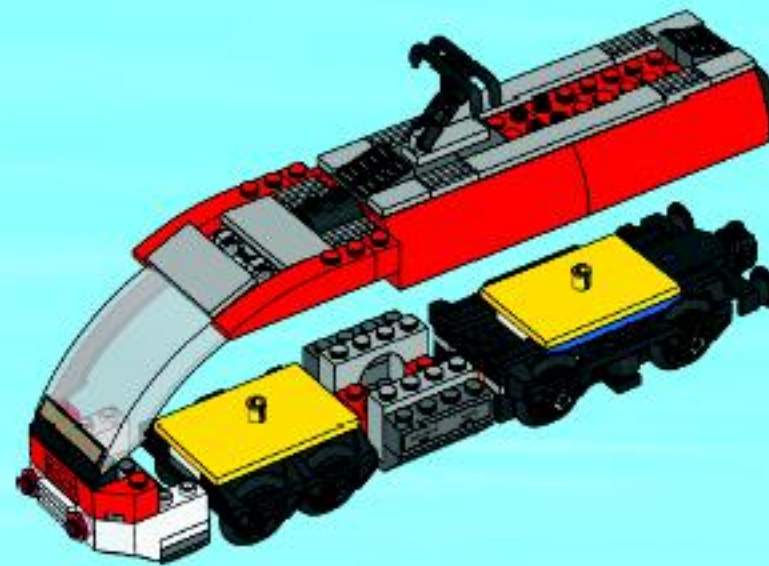

CITY

7938

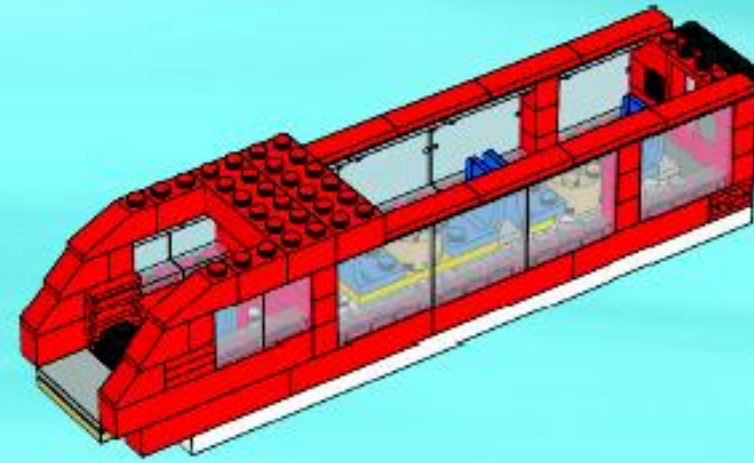



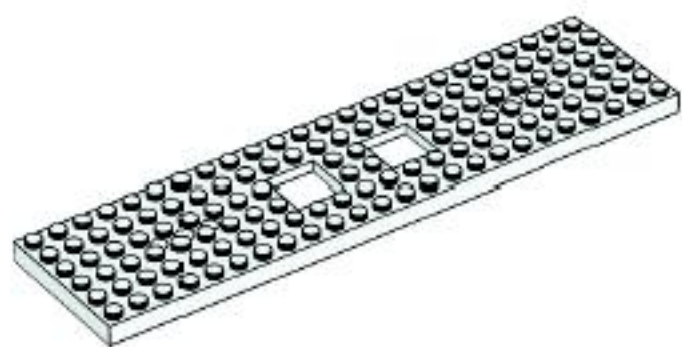

+

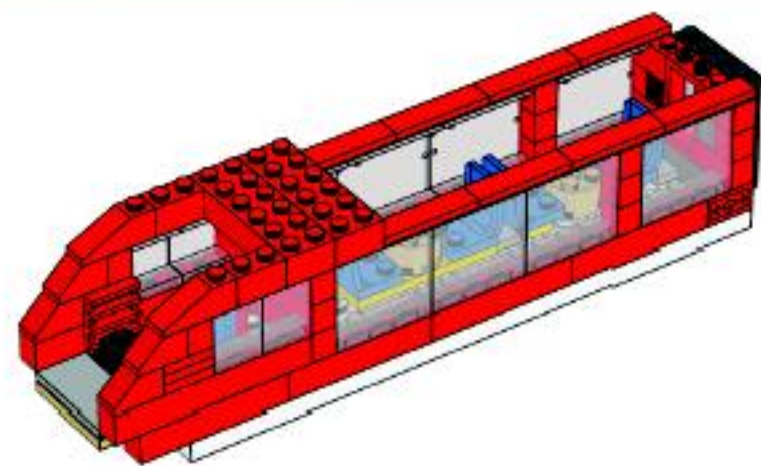

1

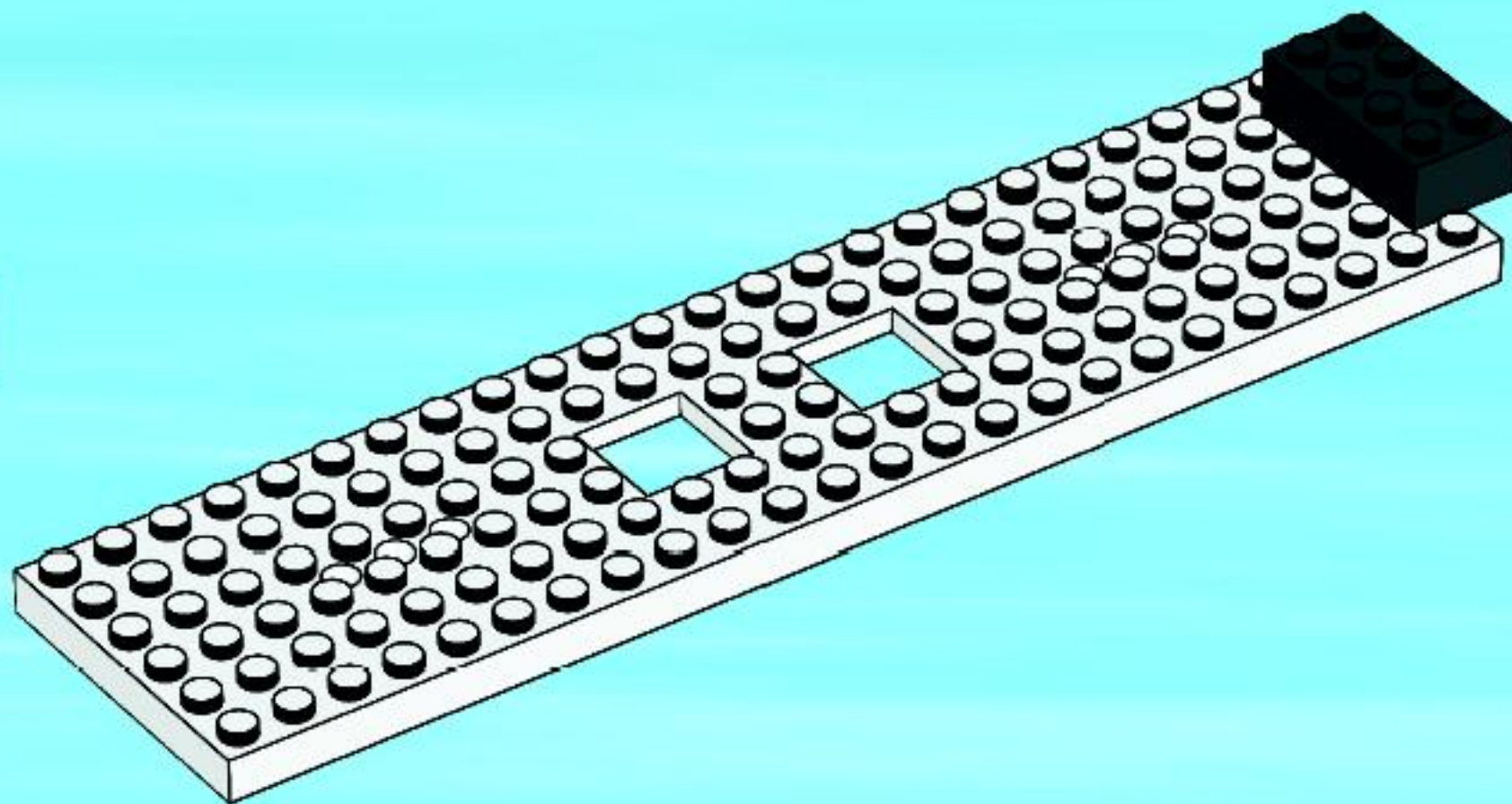

2

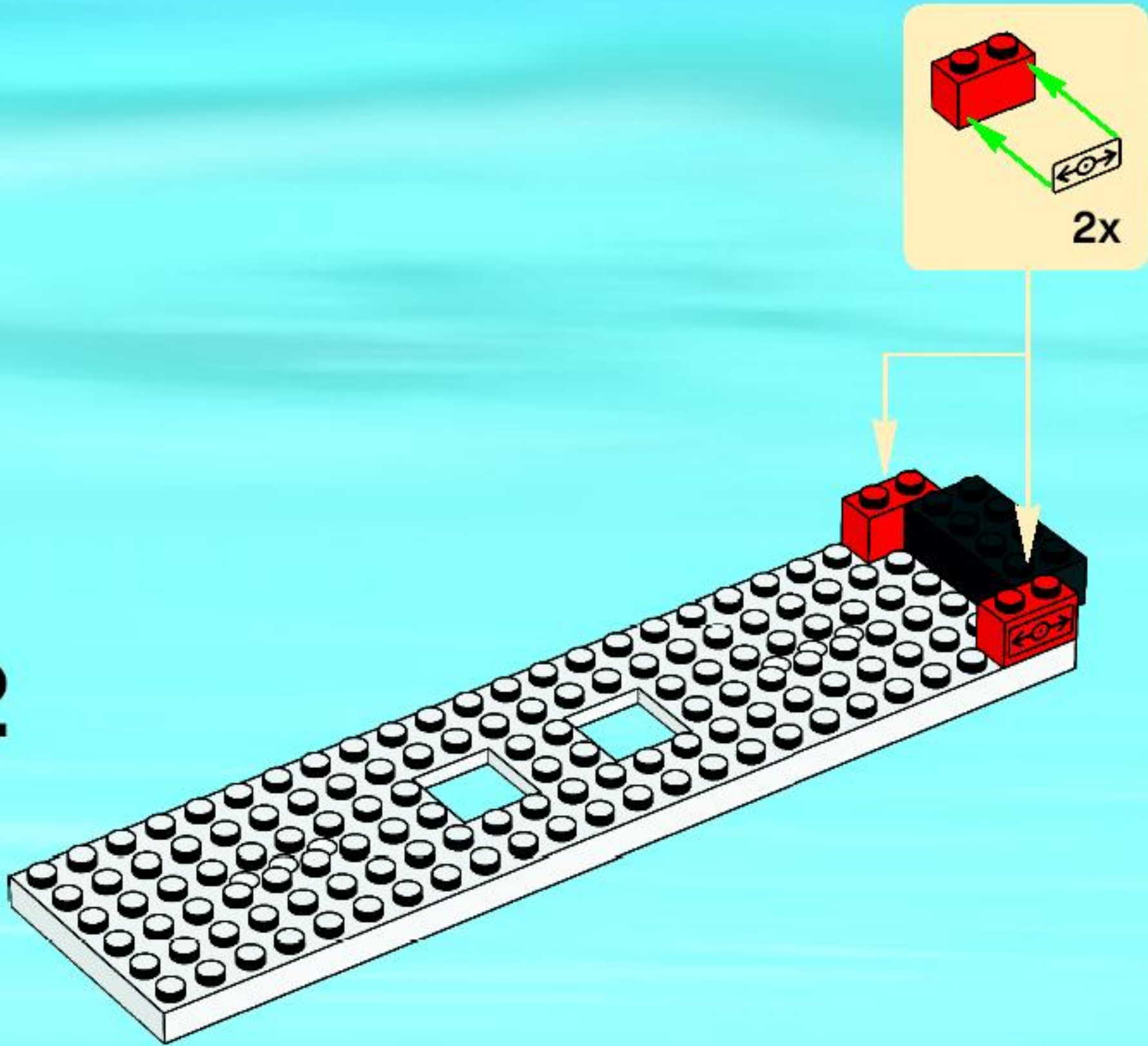

3

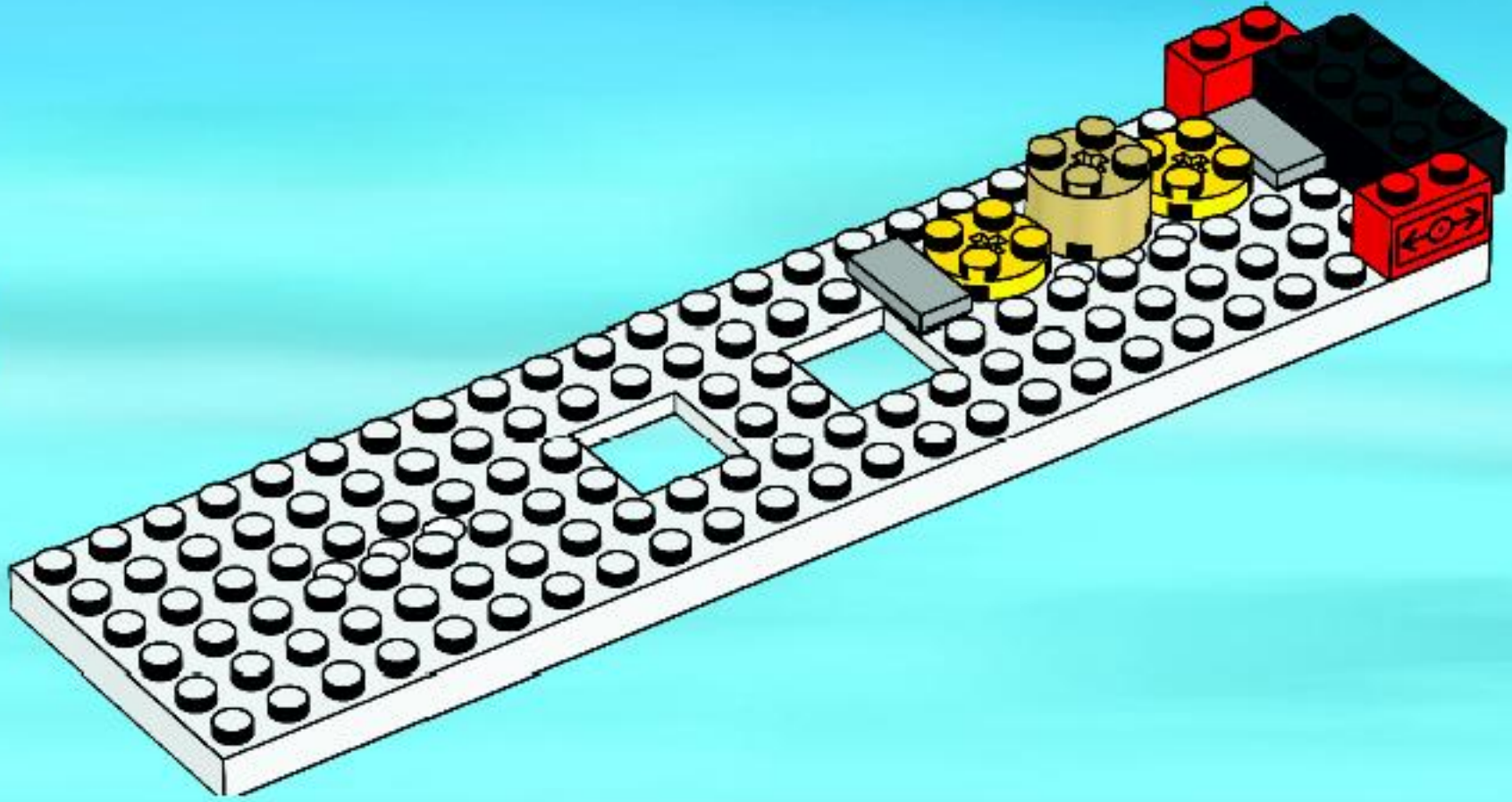

4

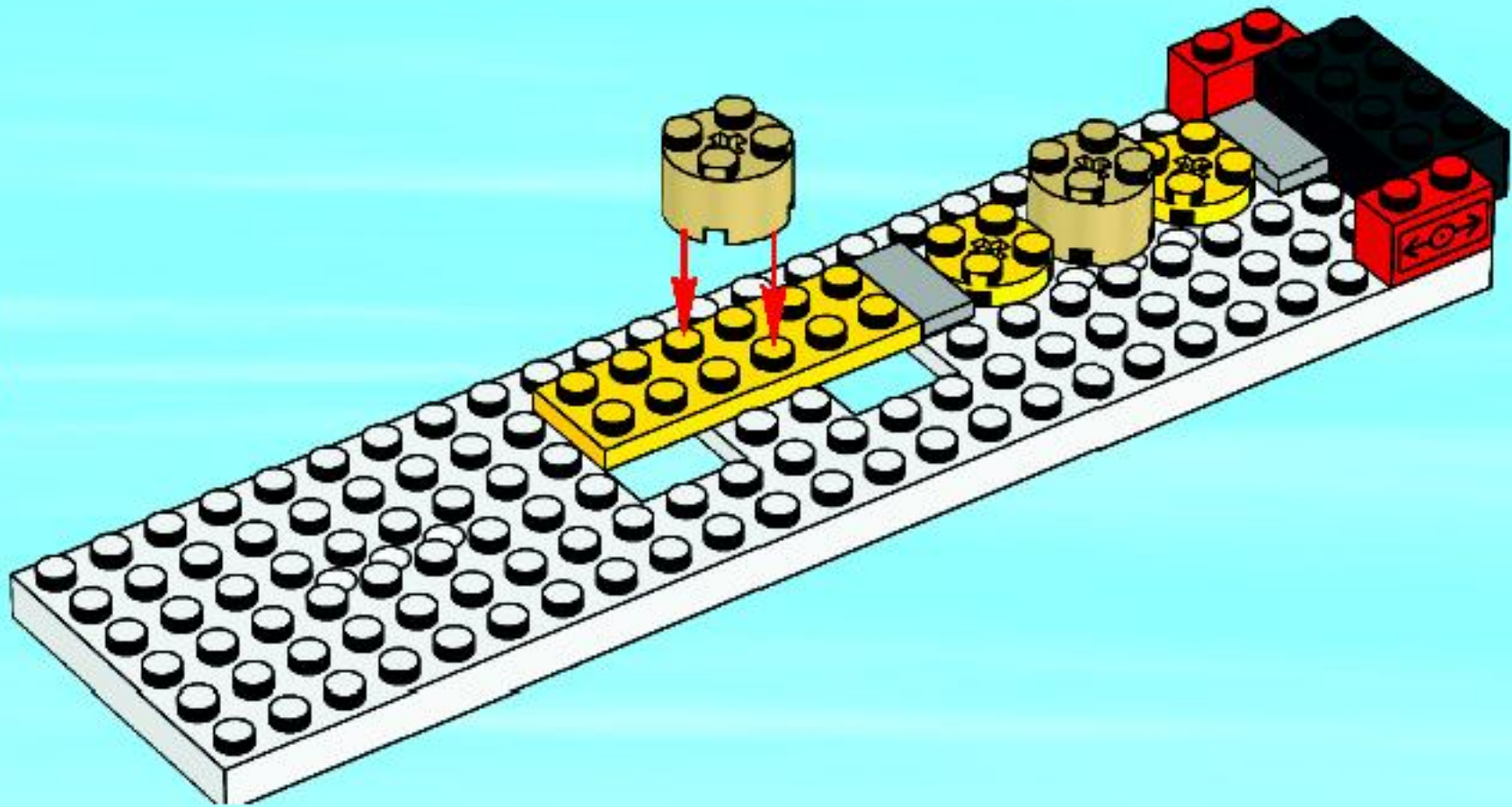

5

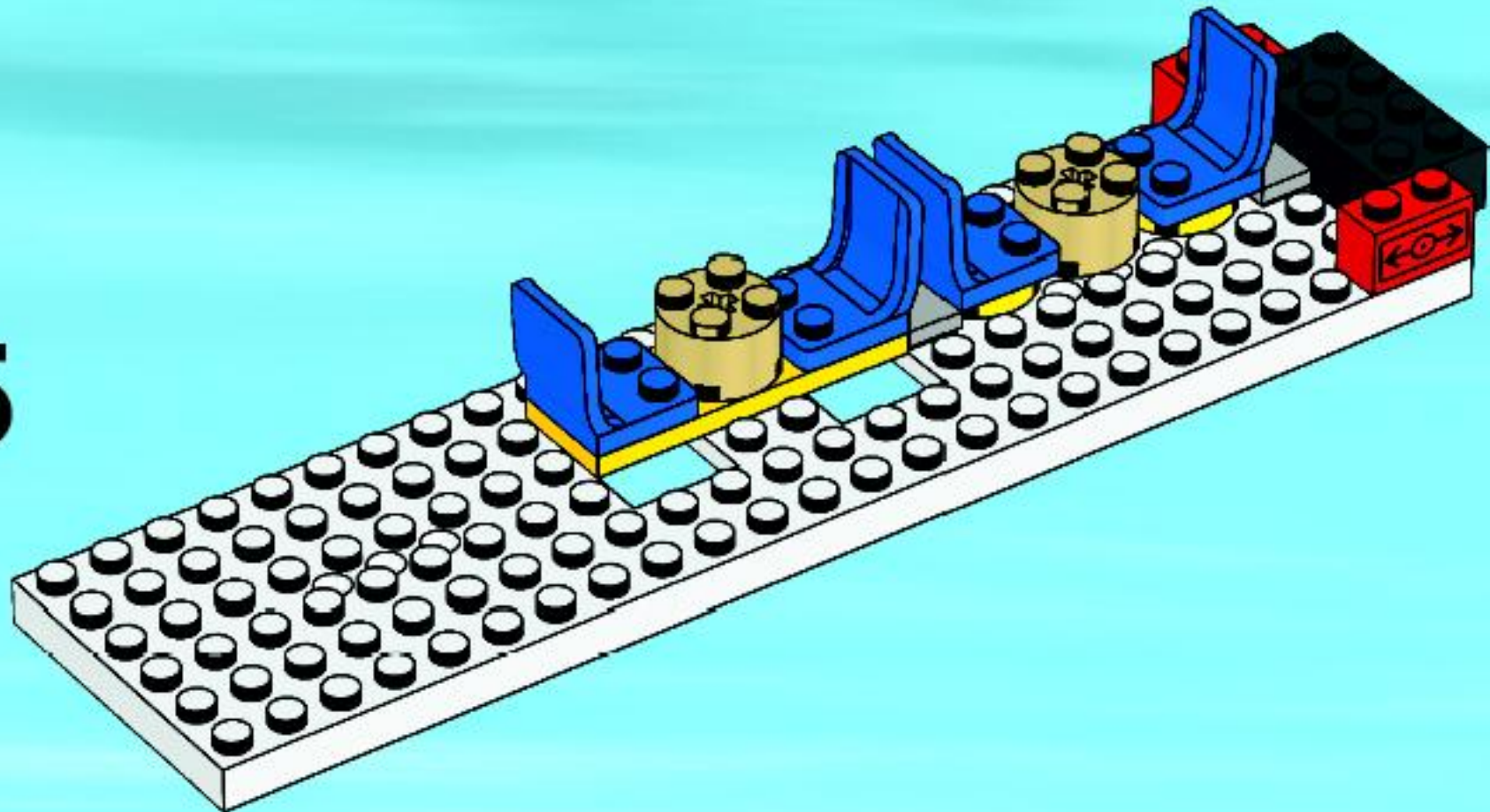

6

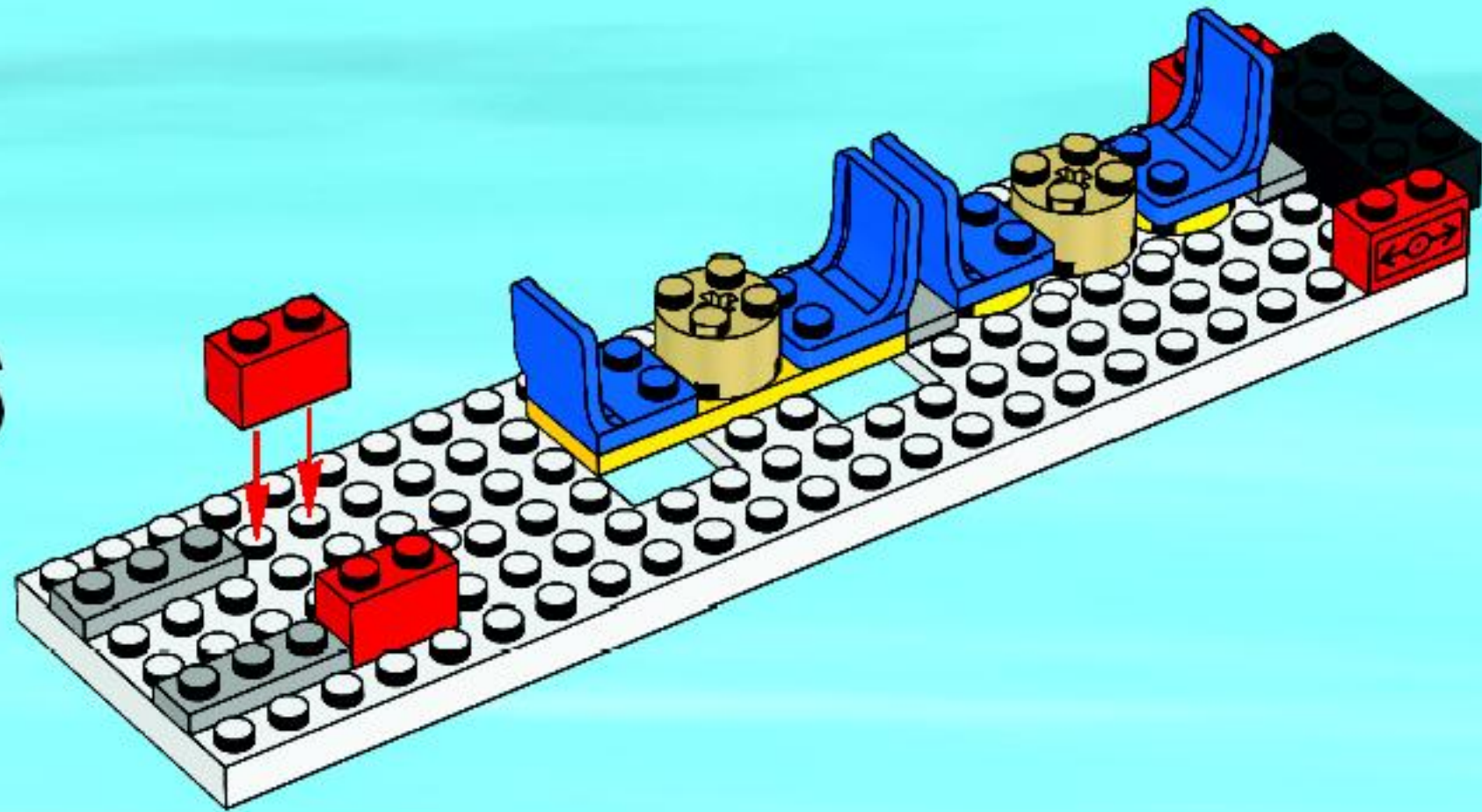

7

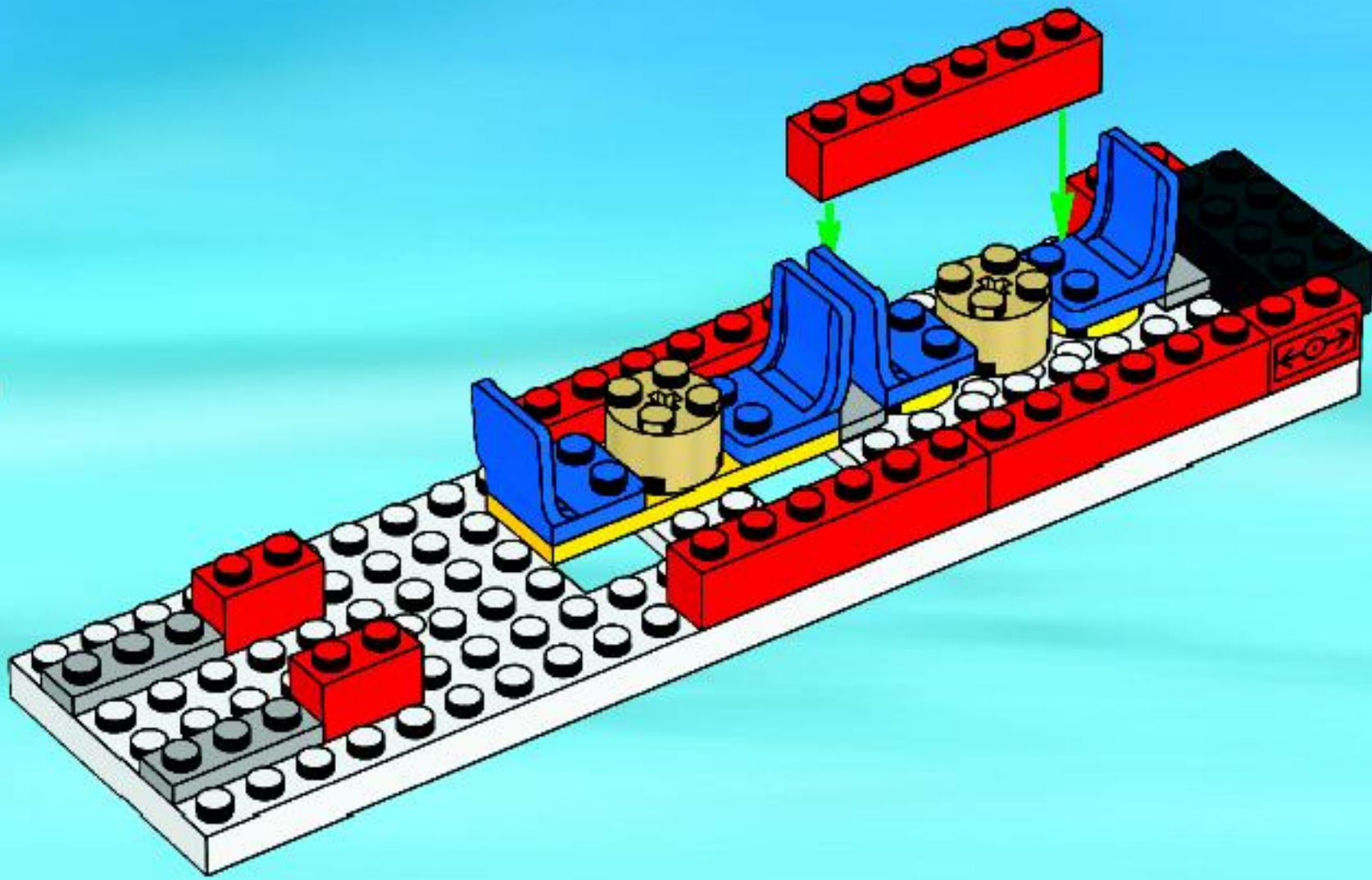

8

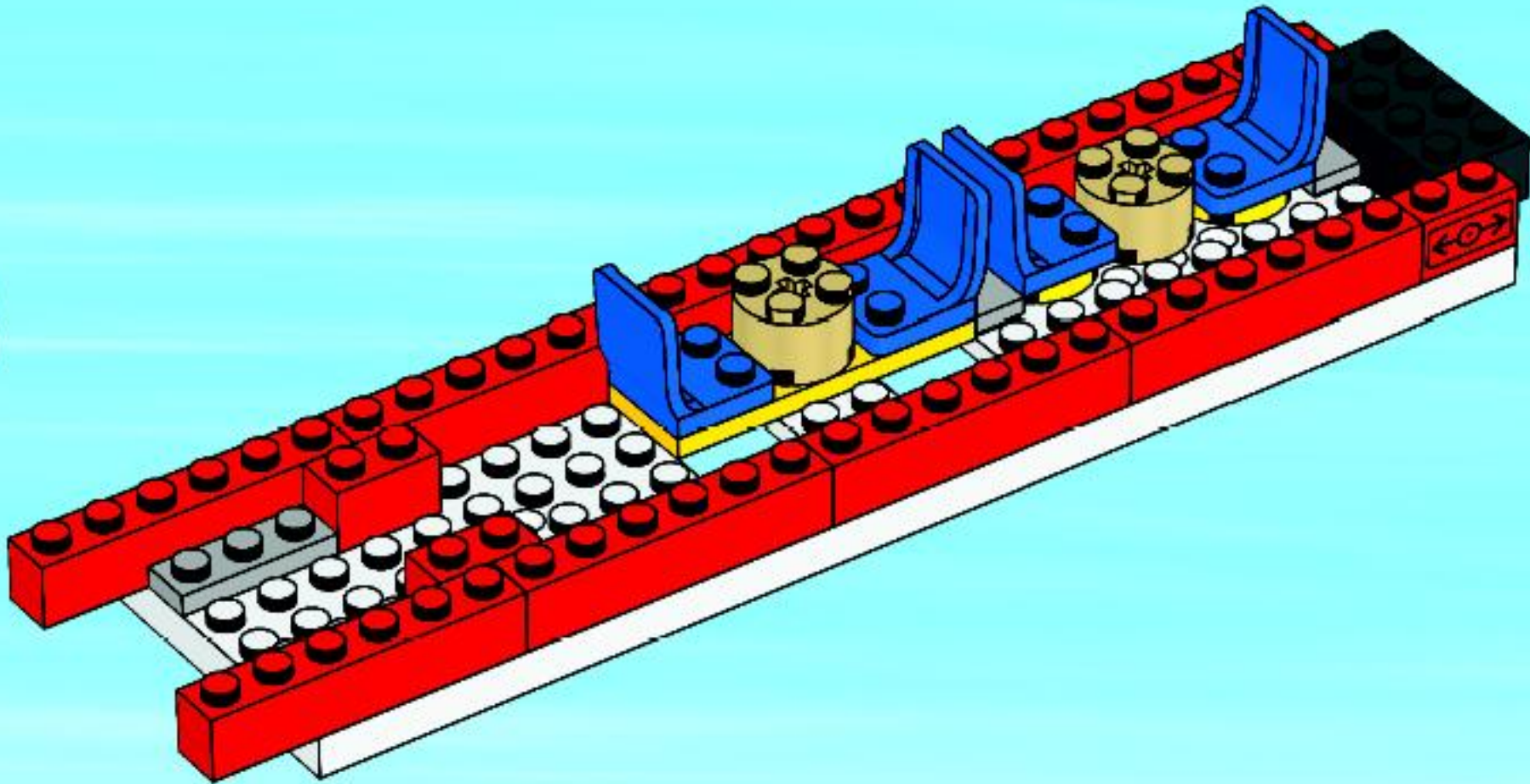

9

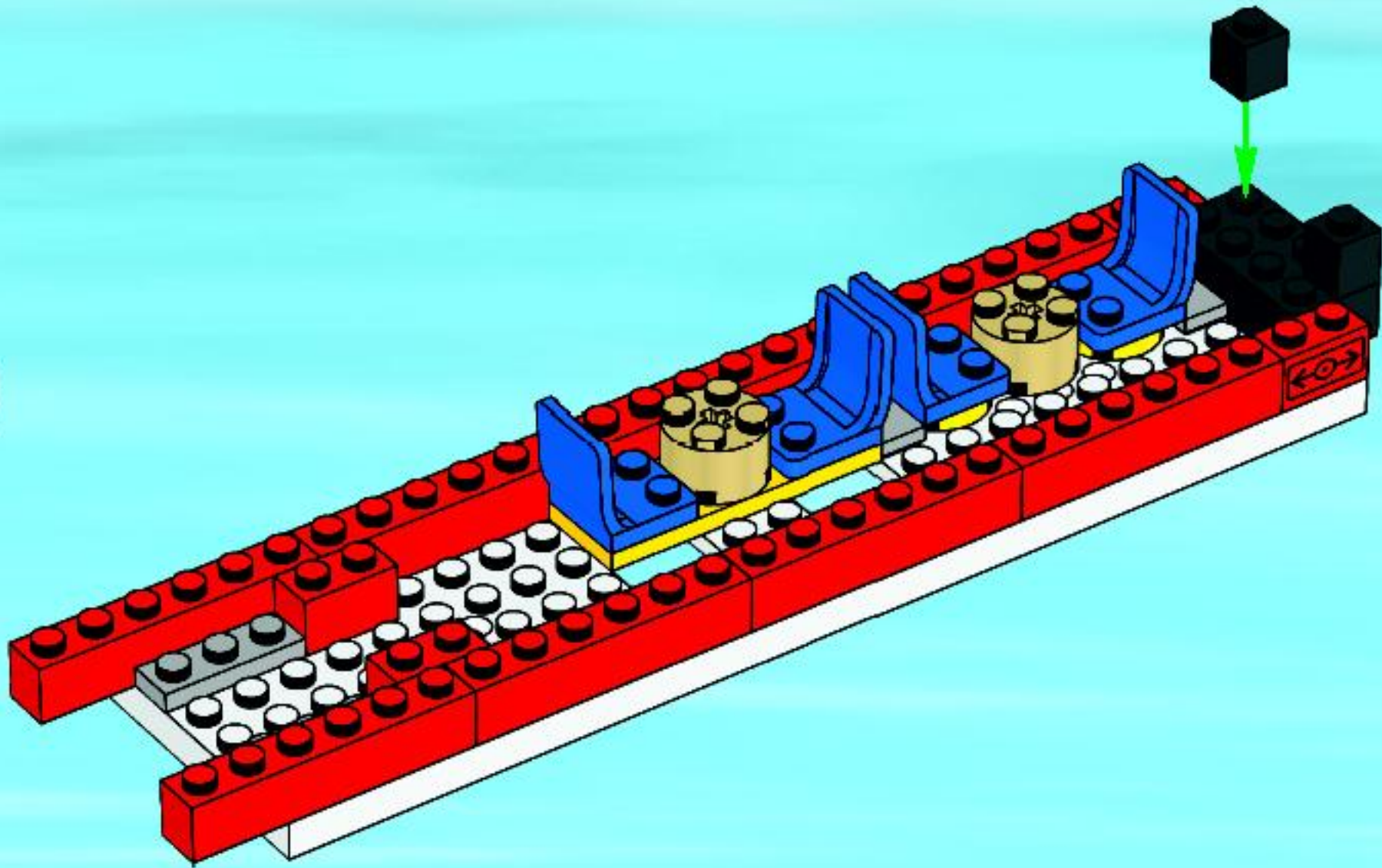

10

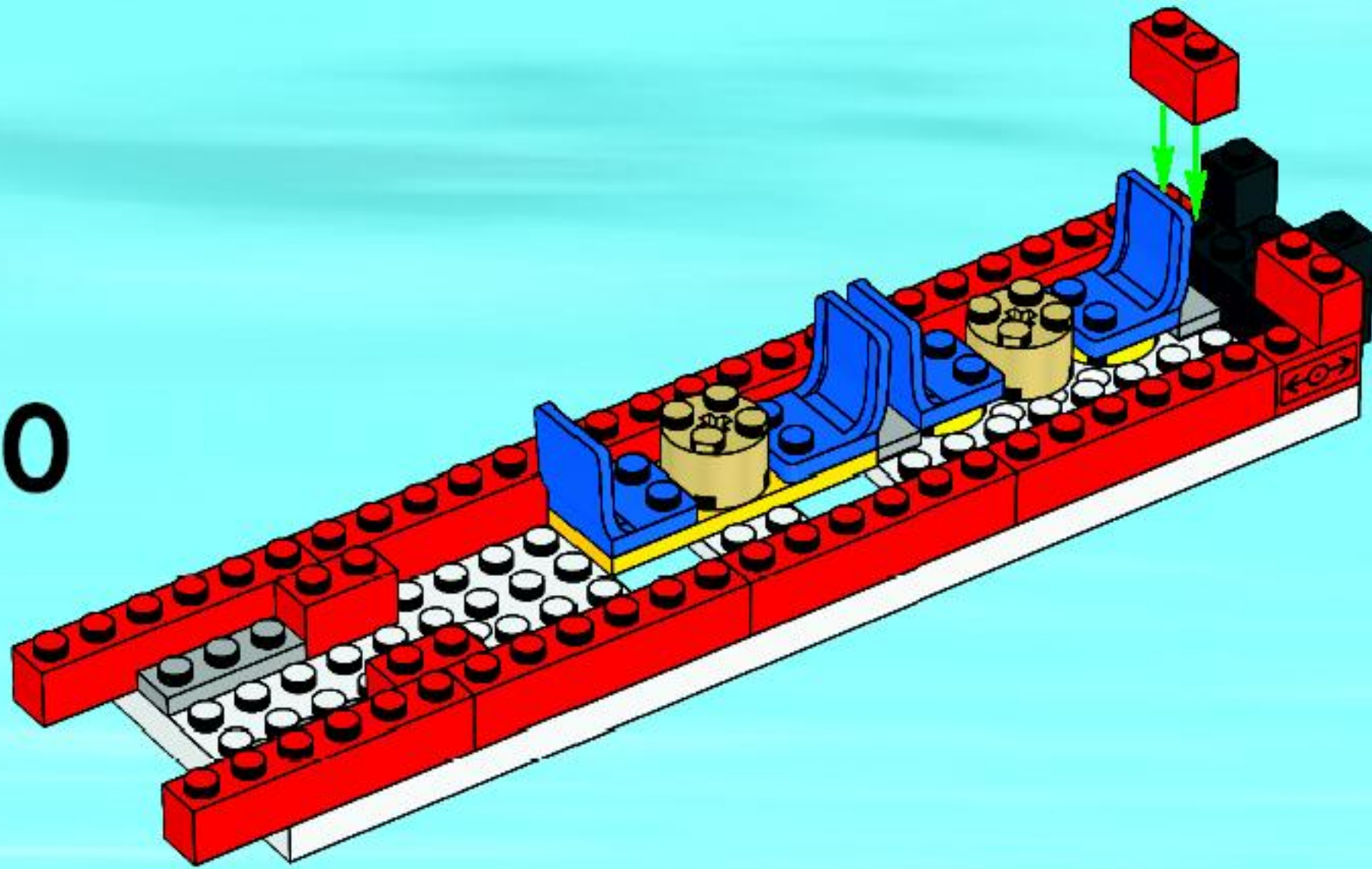

11

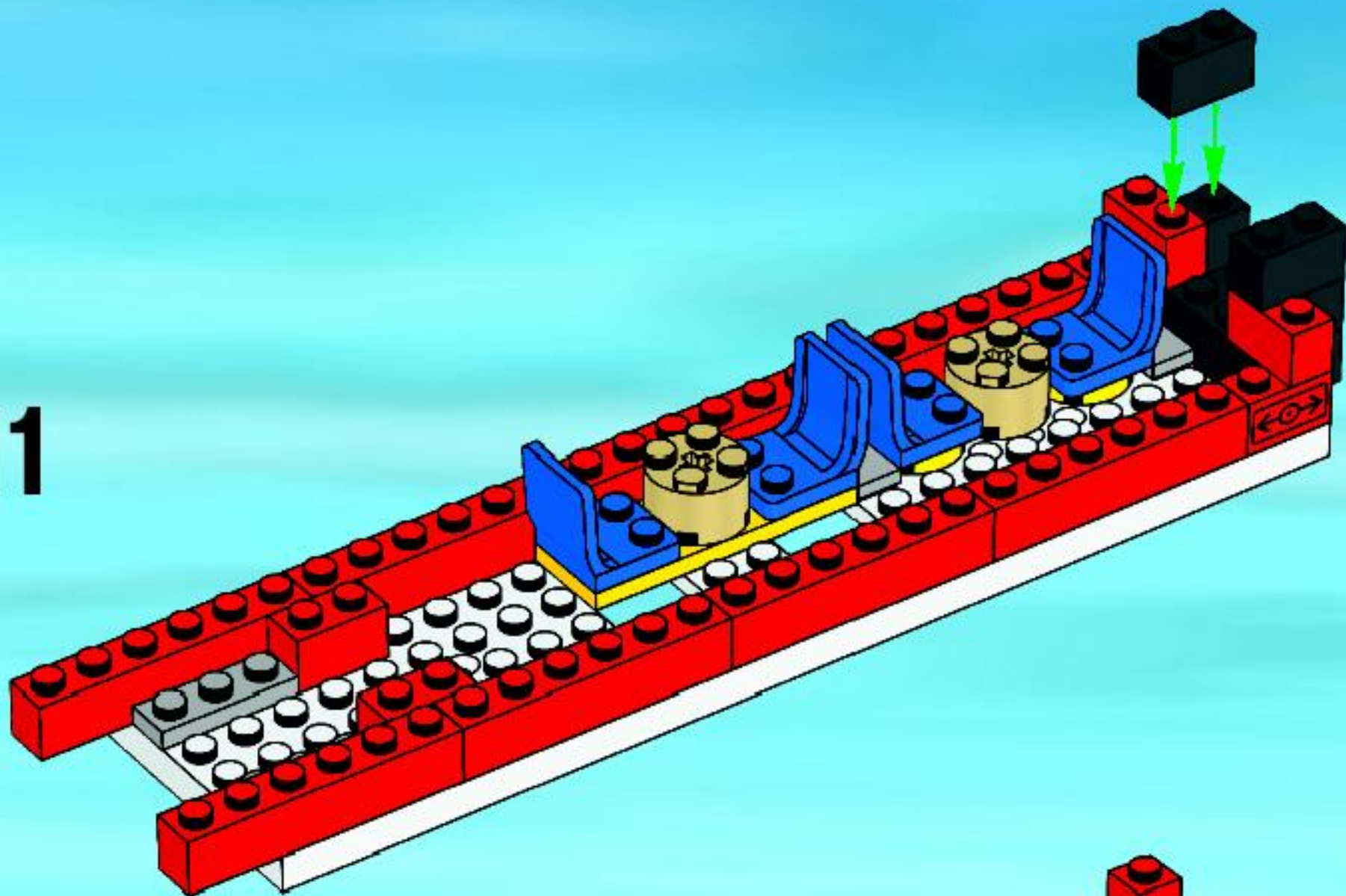

12

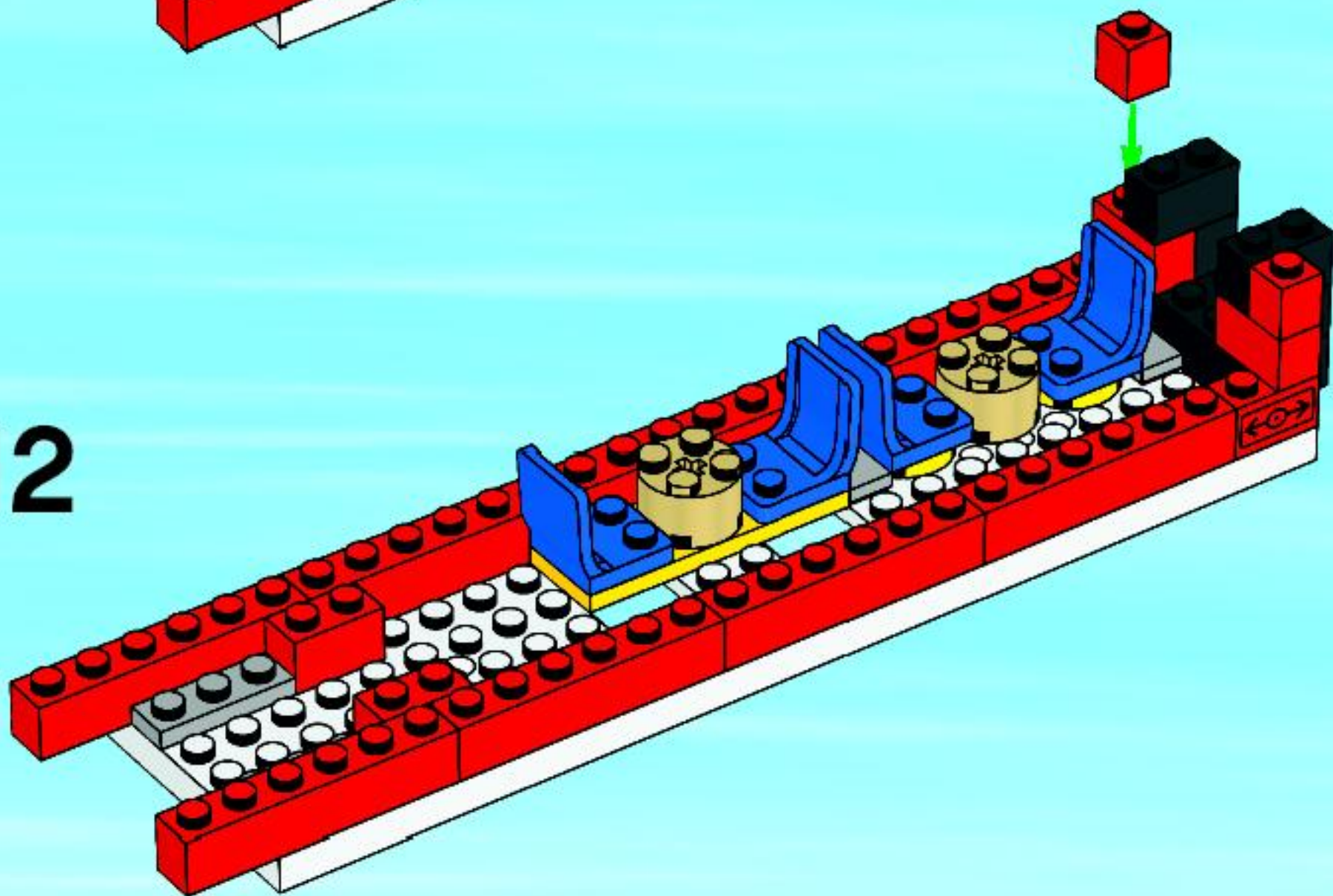

13

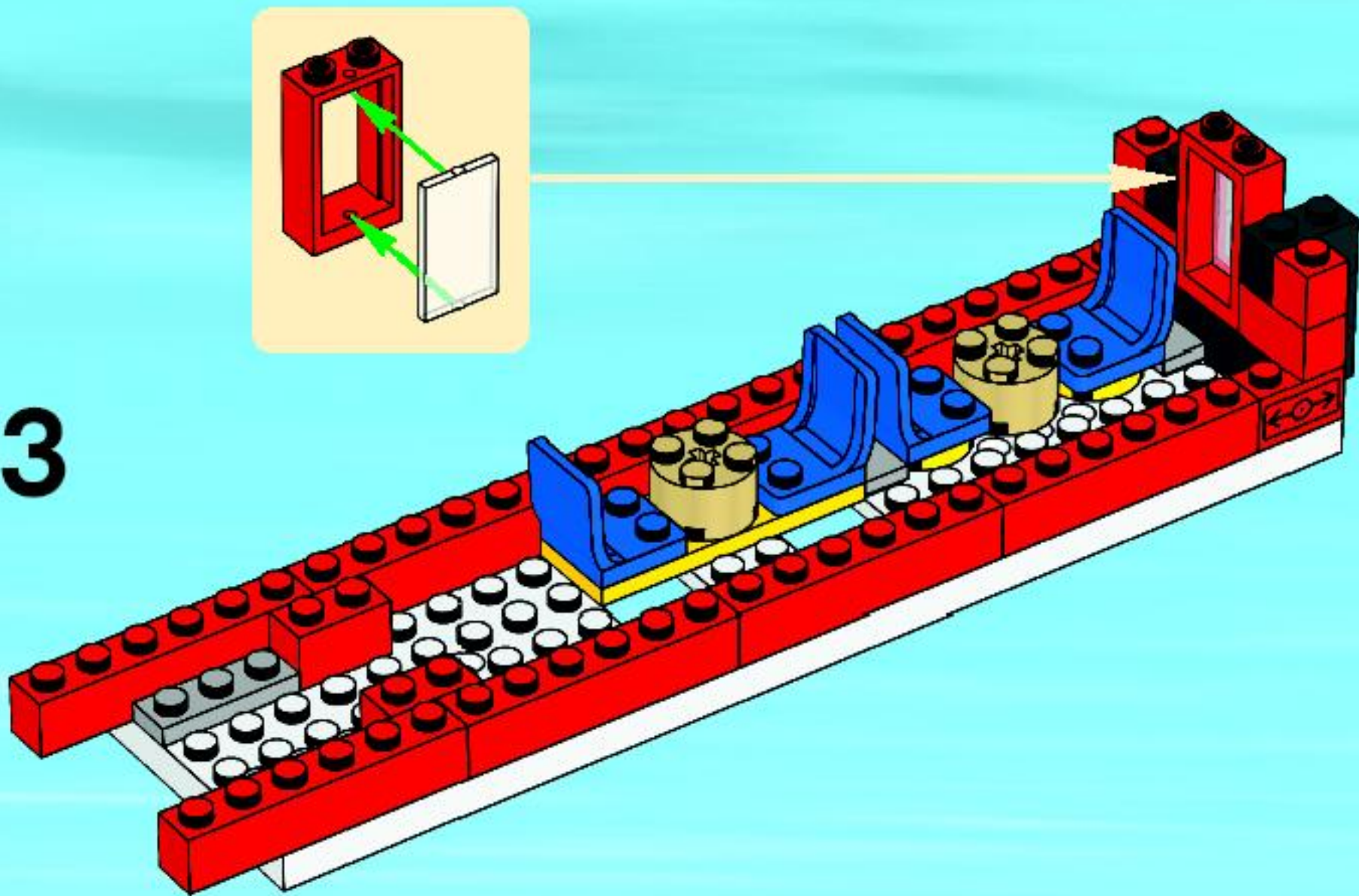

14

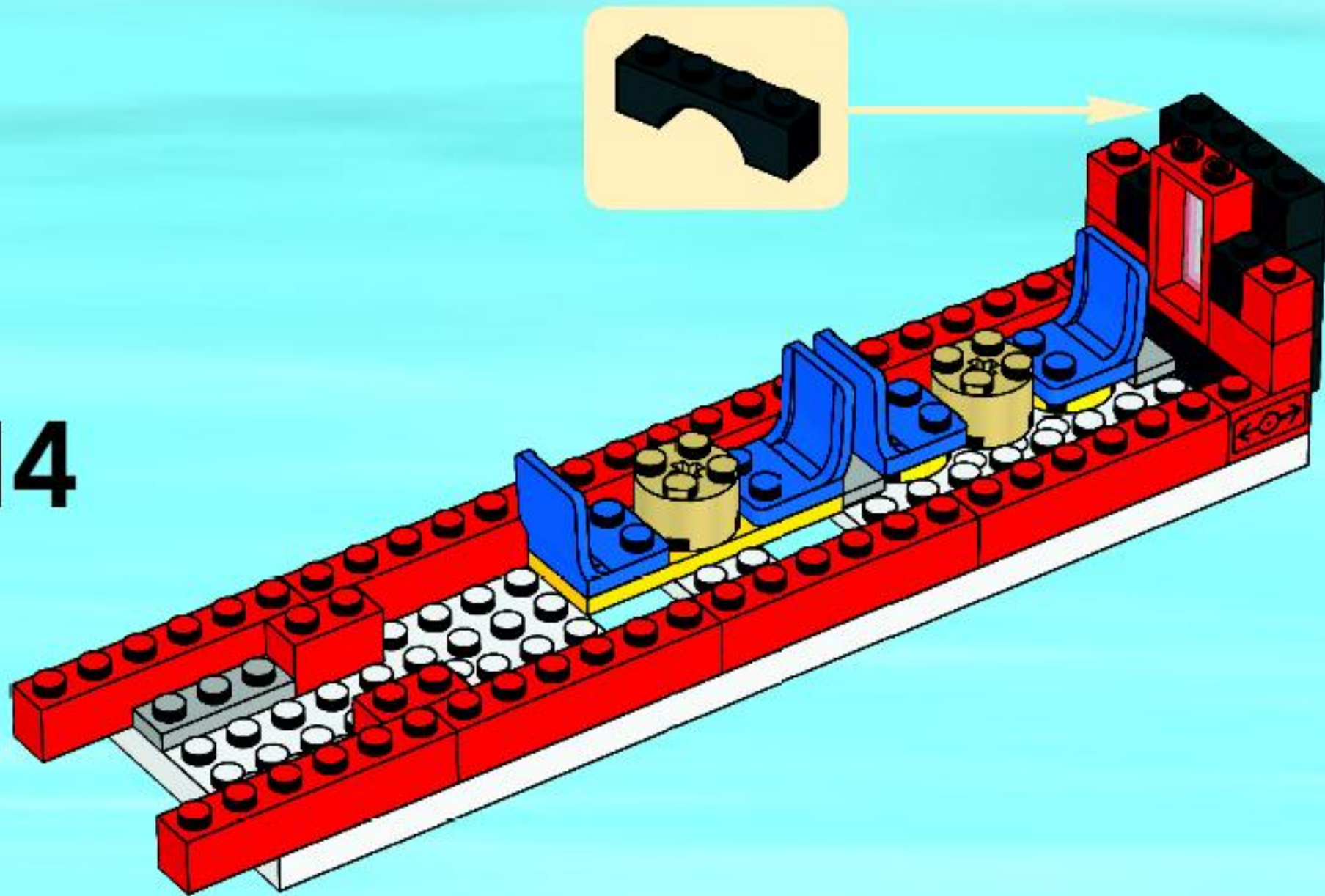

15

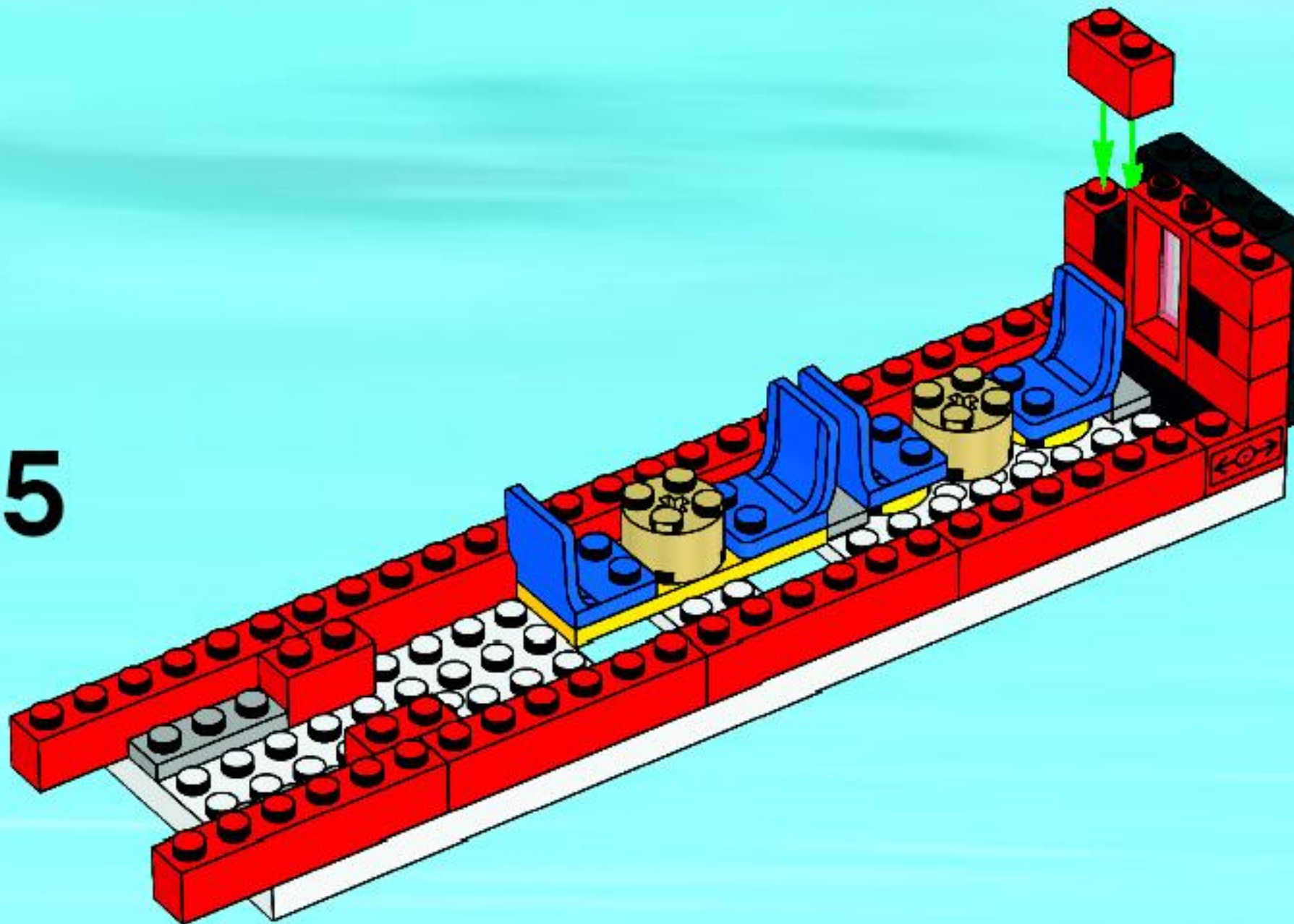

16

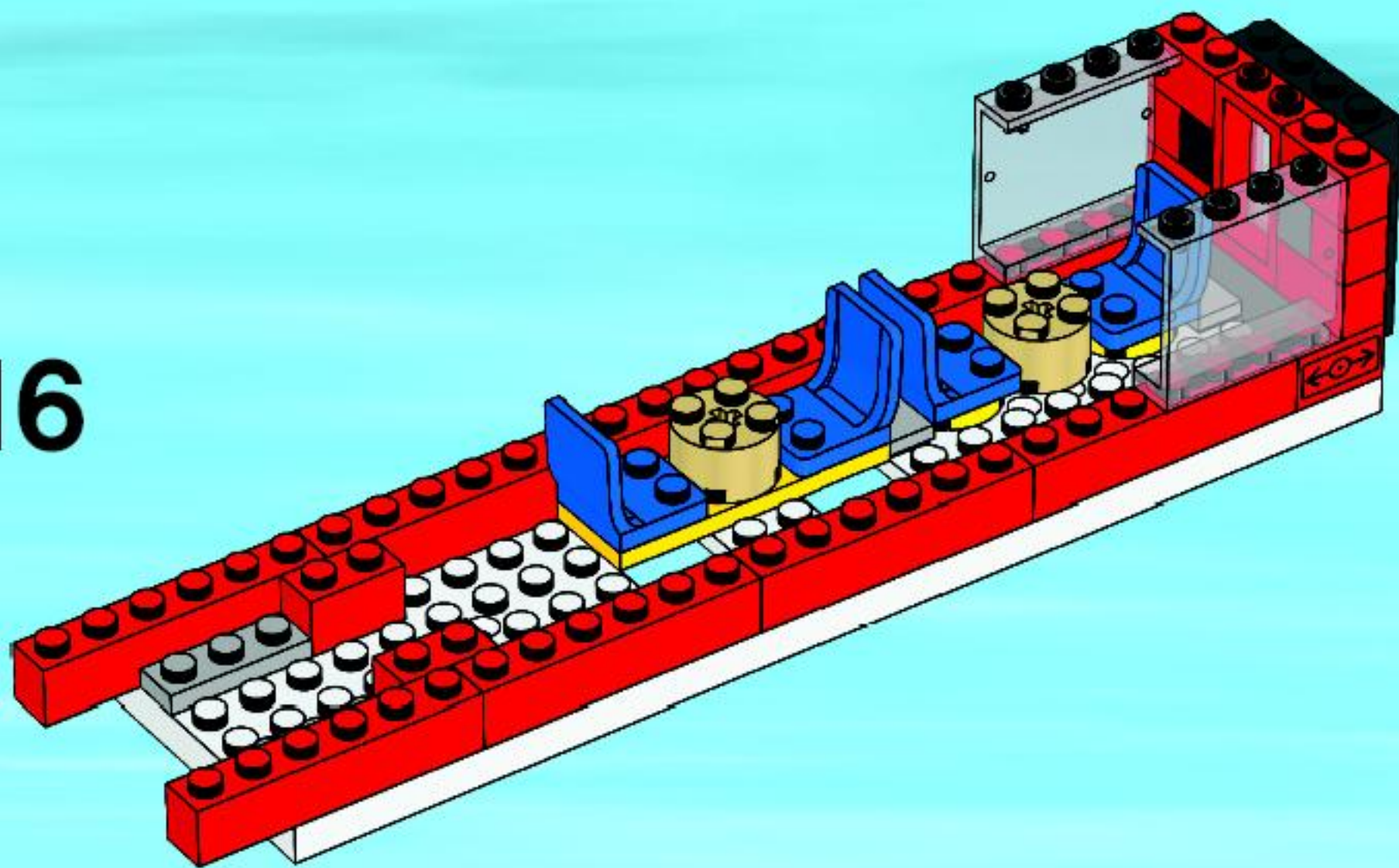

17

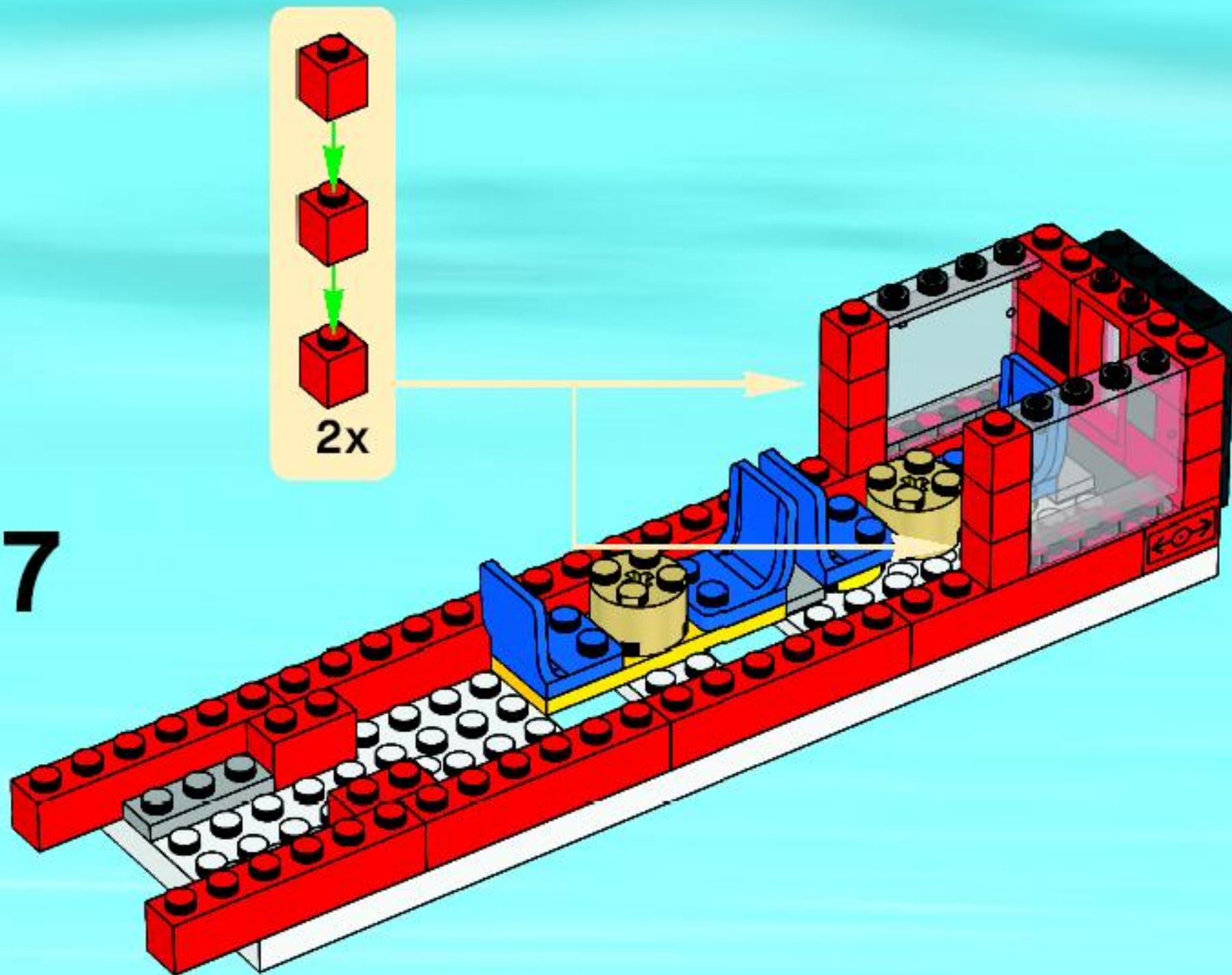

18

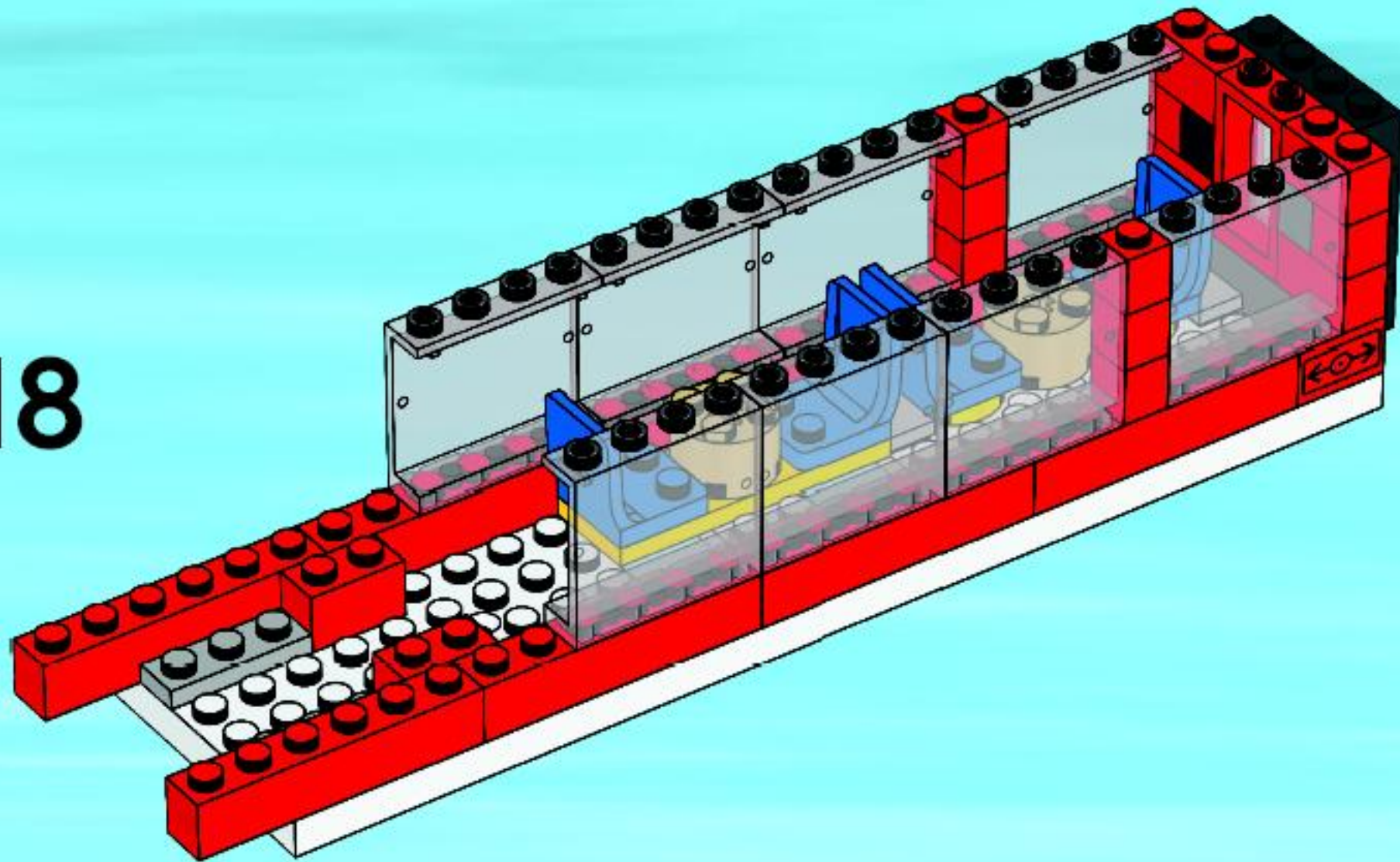

19

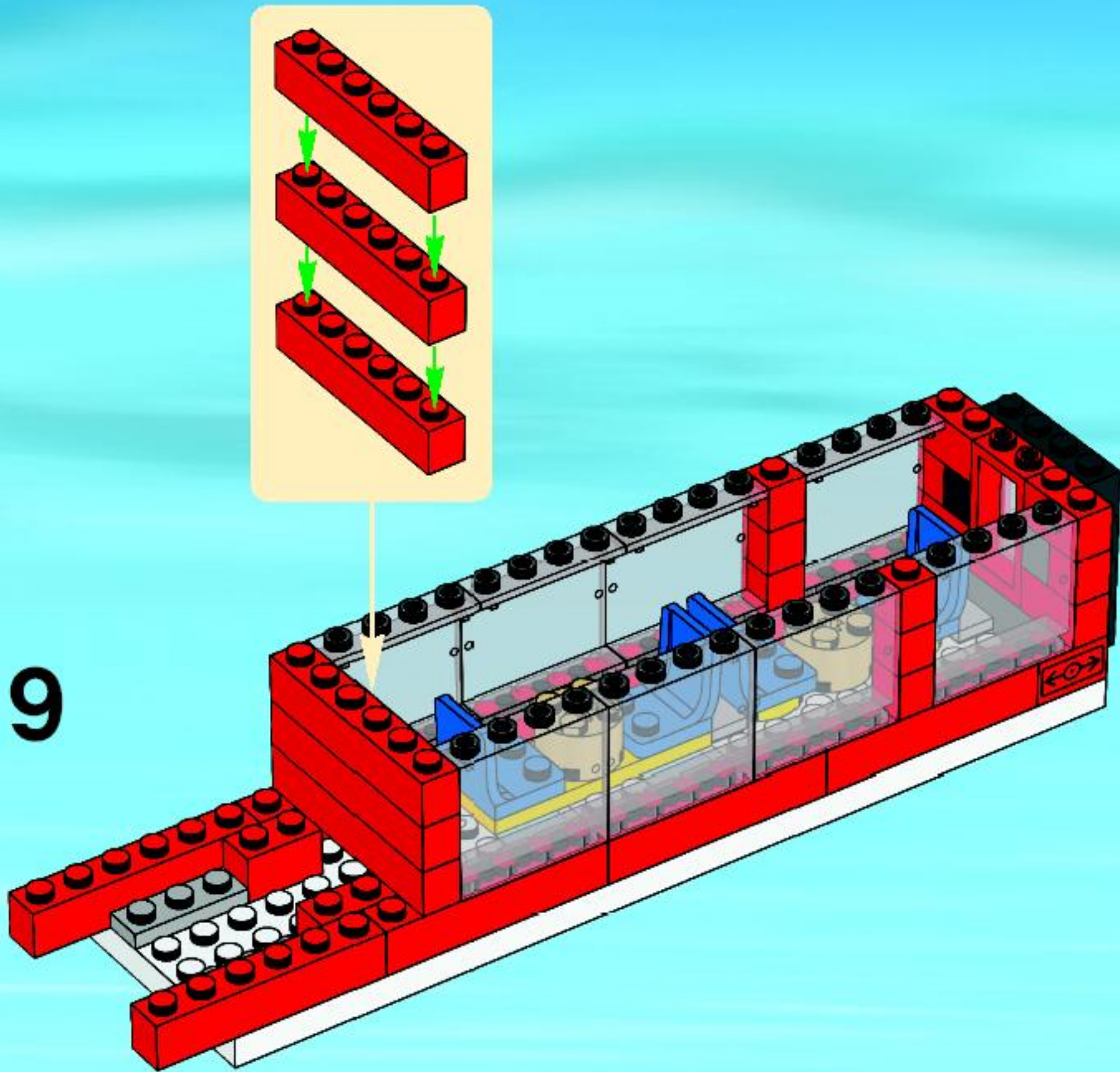

20

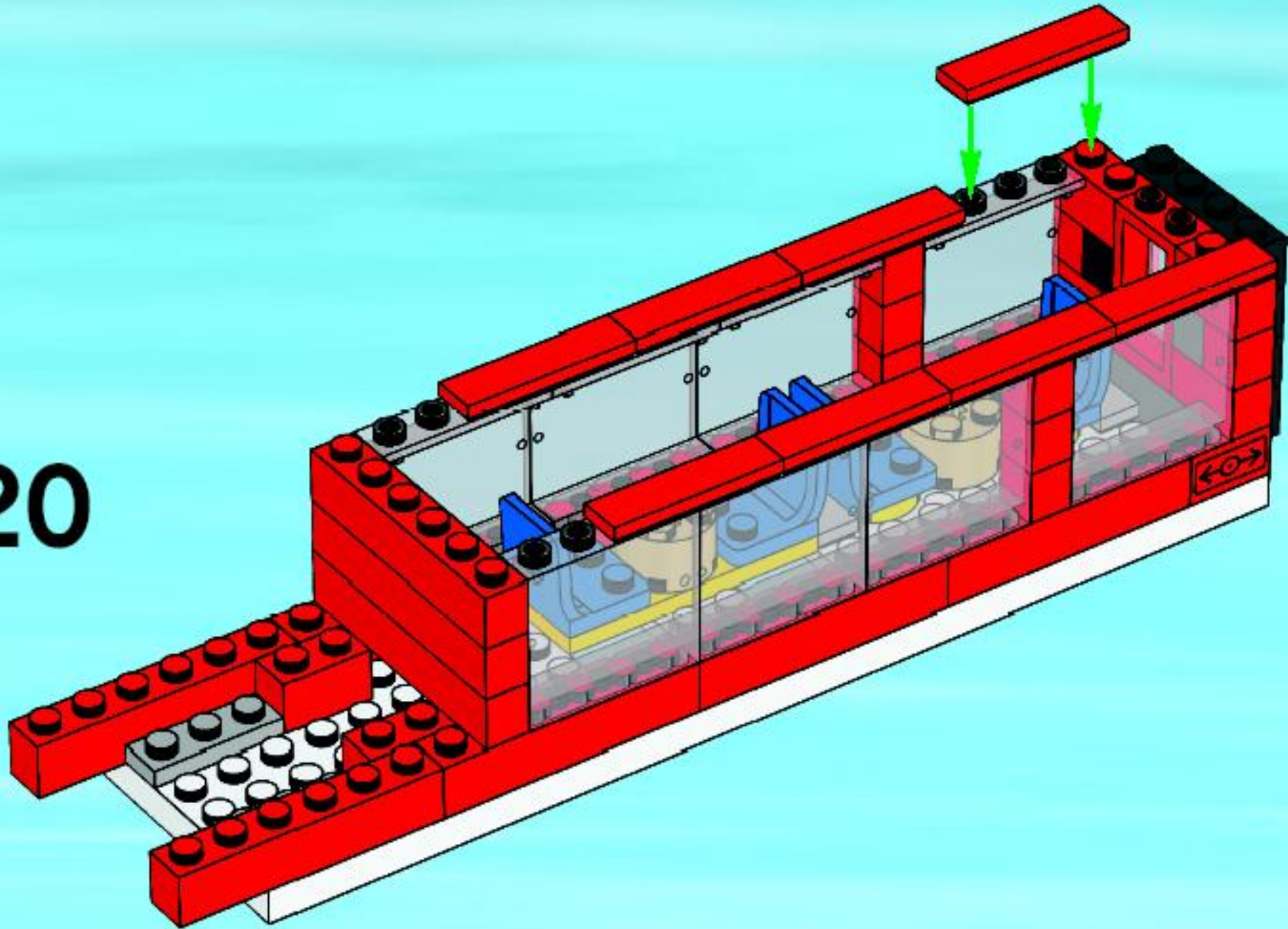

21

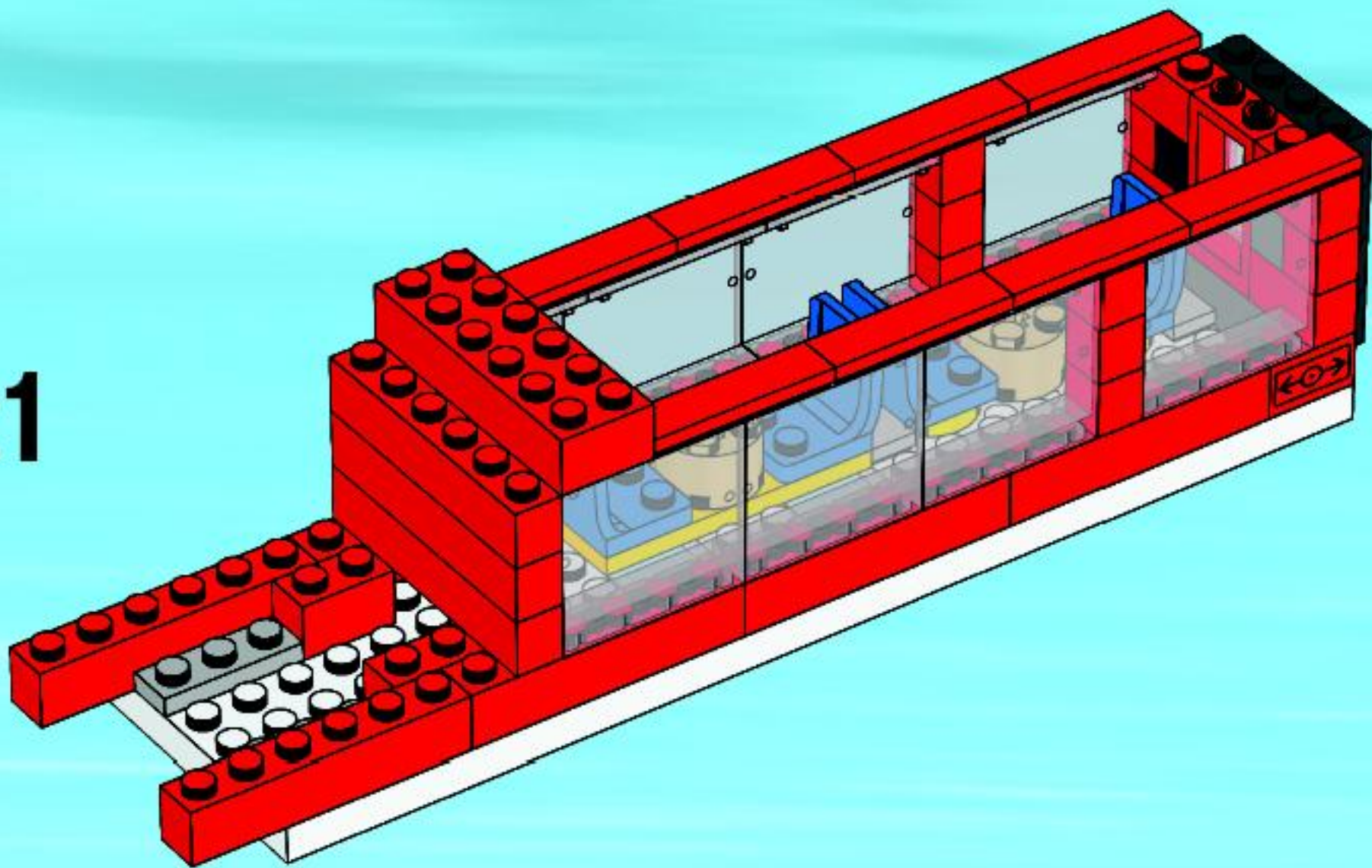

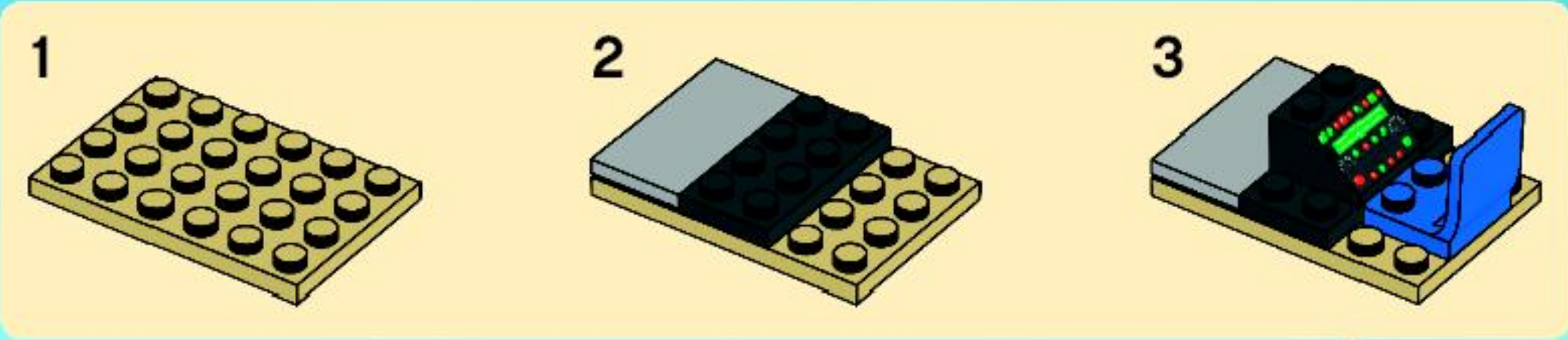

22

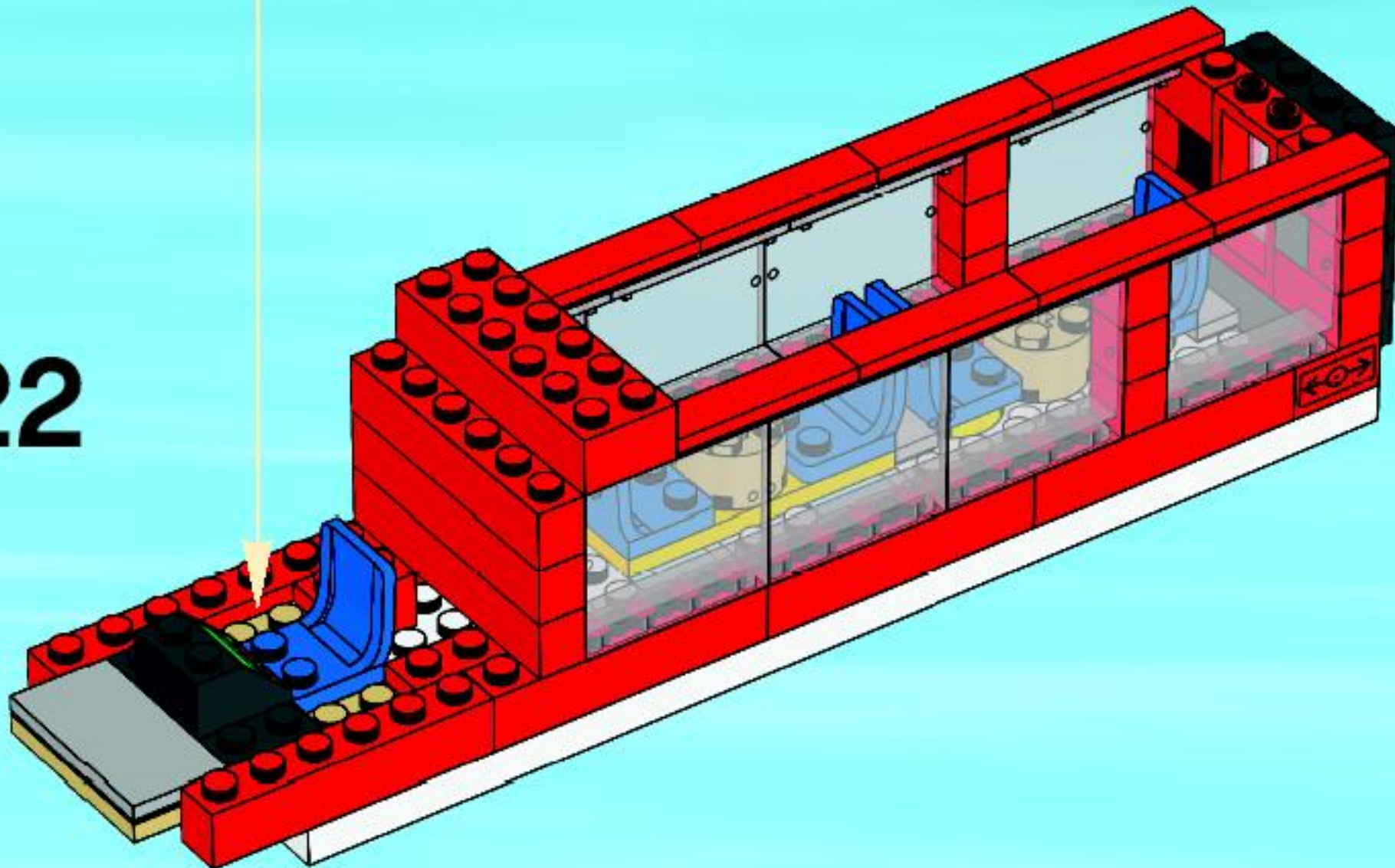

23

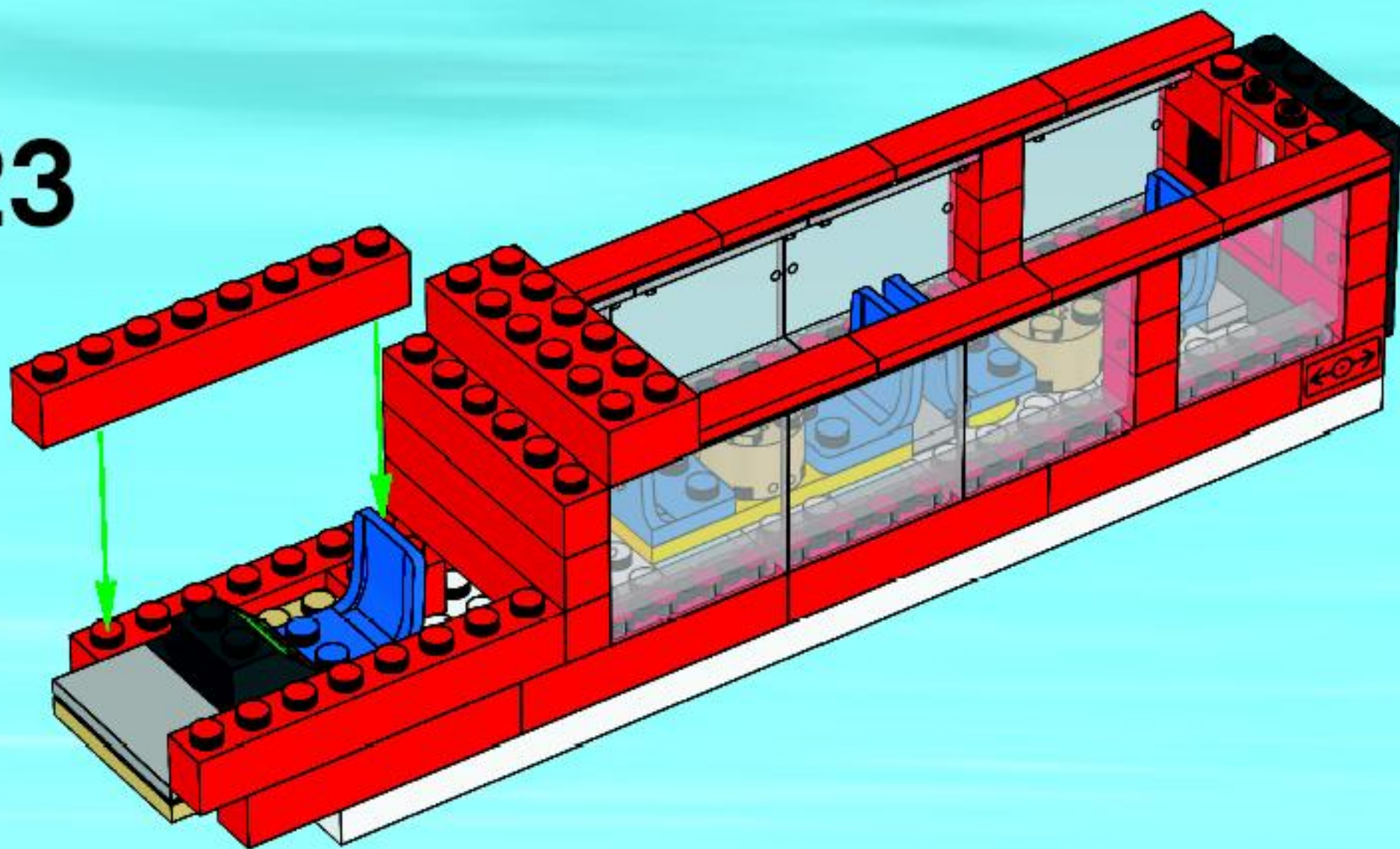

24

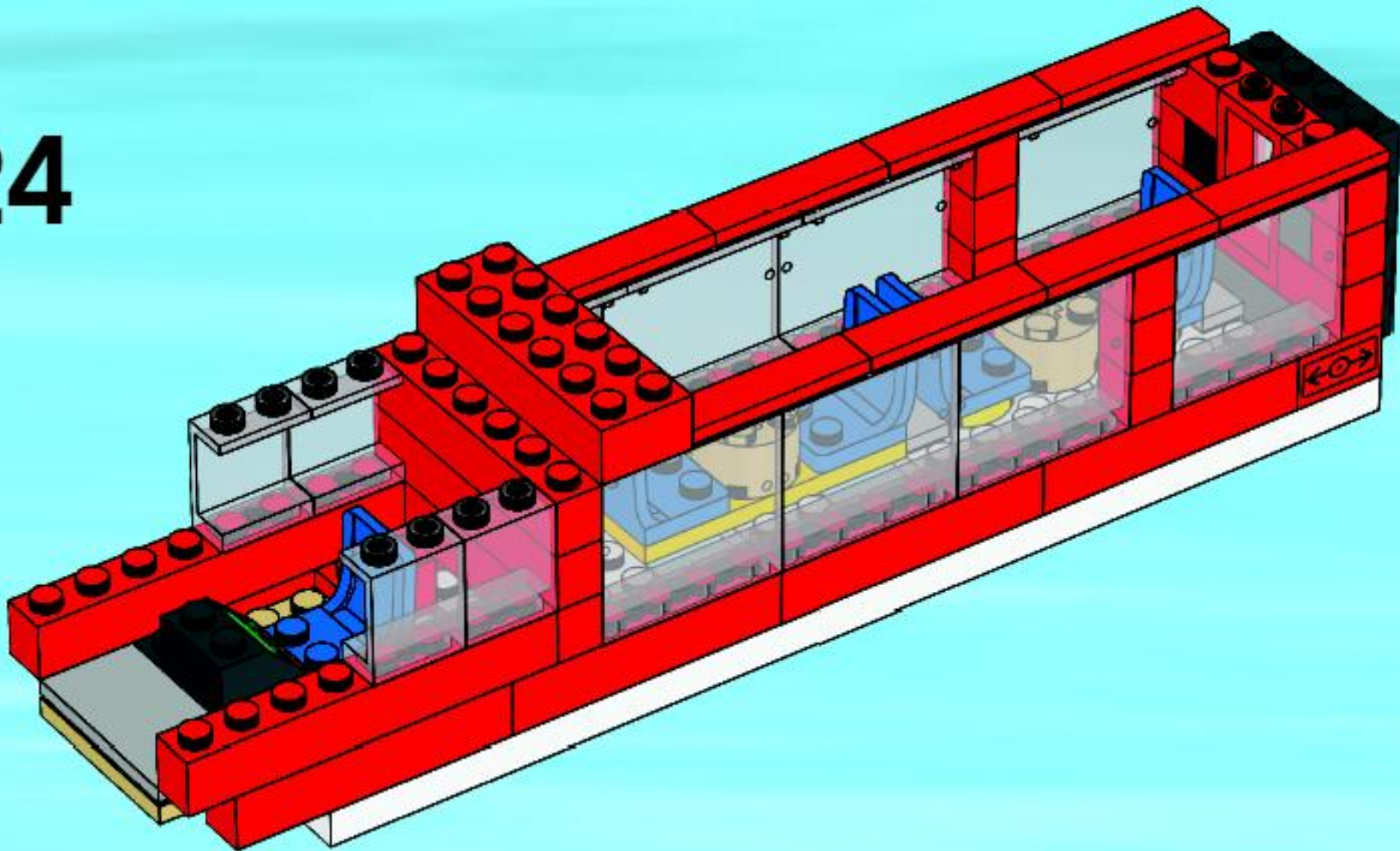

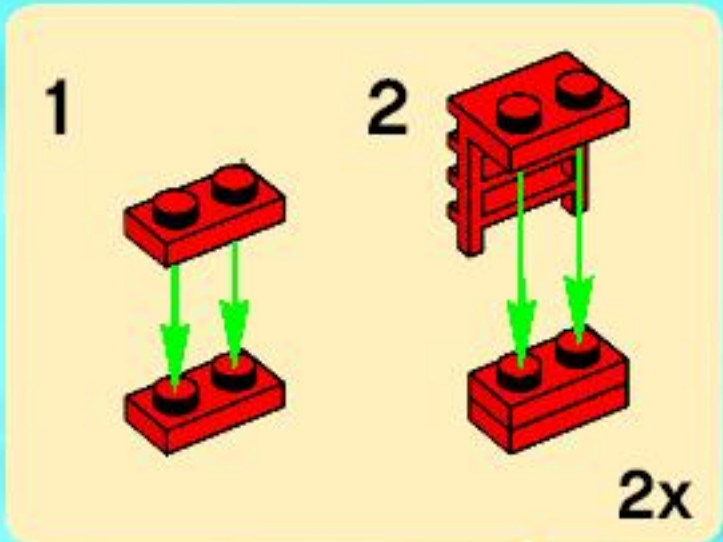

25

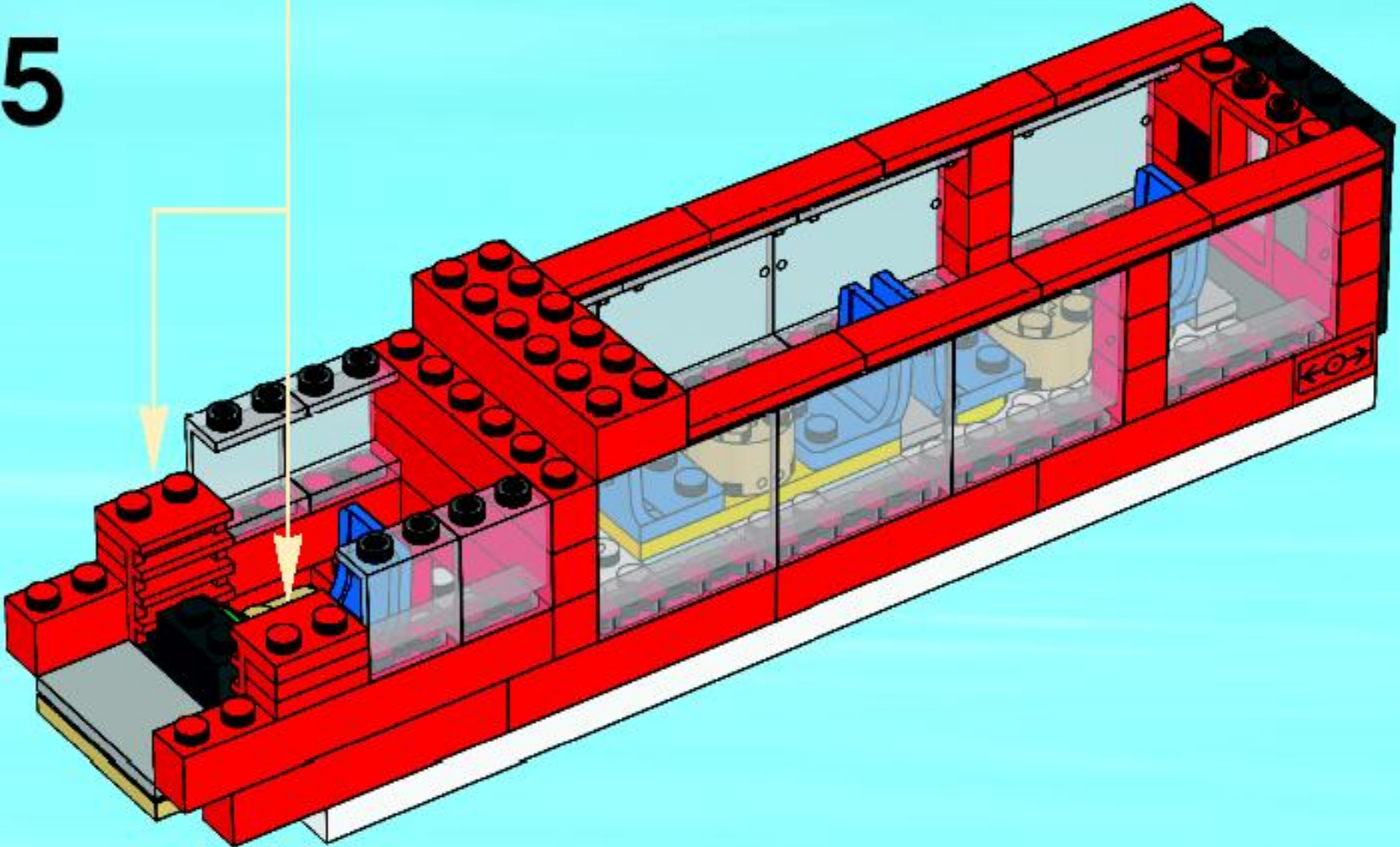

26

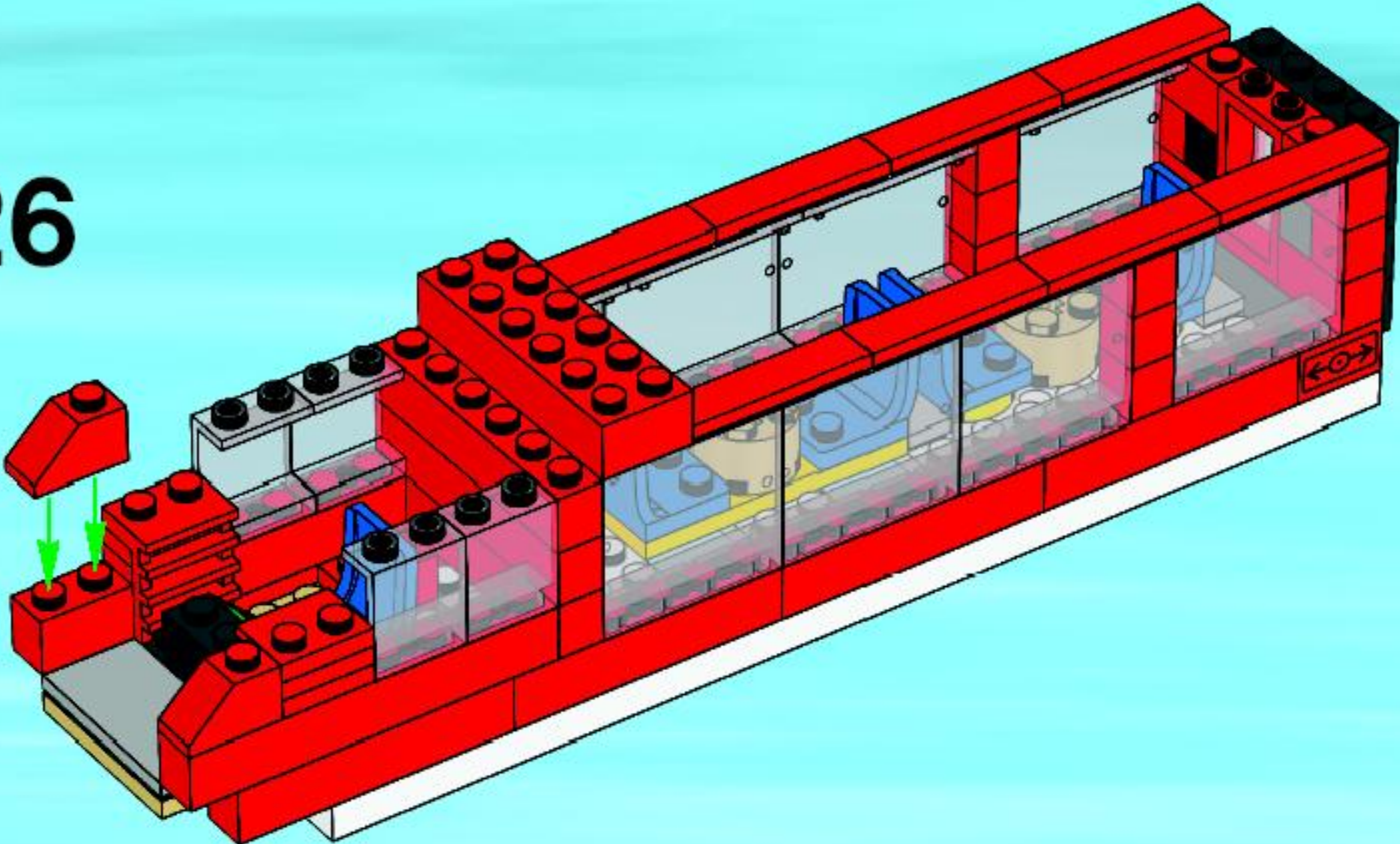

27

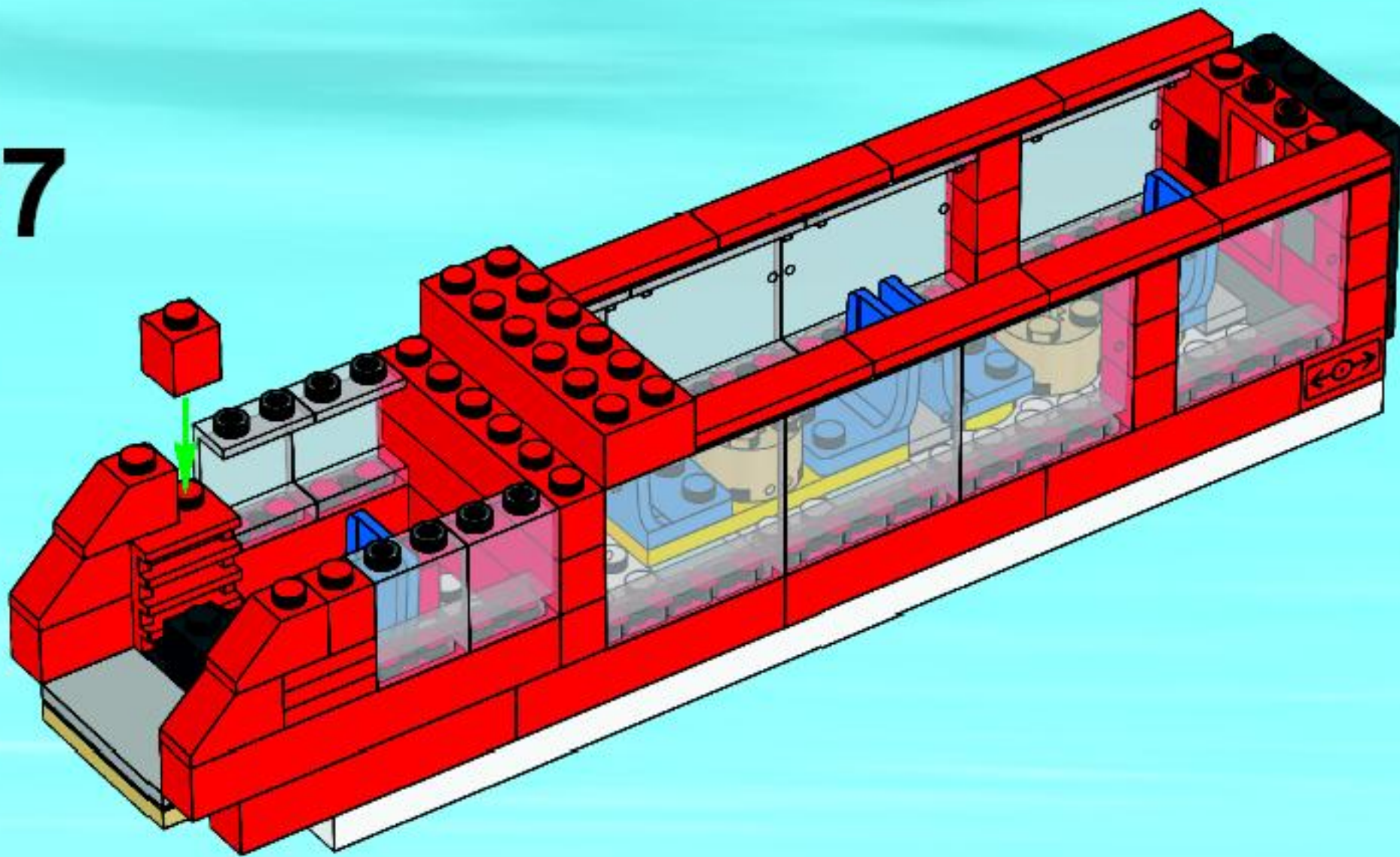

28

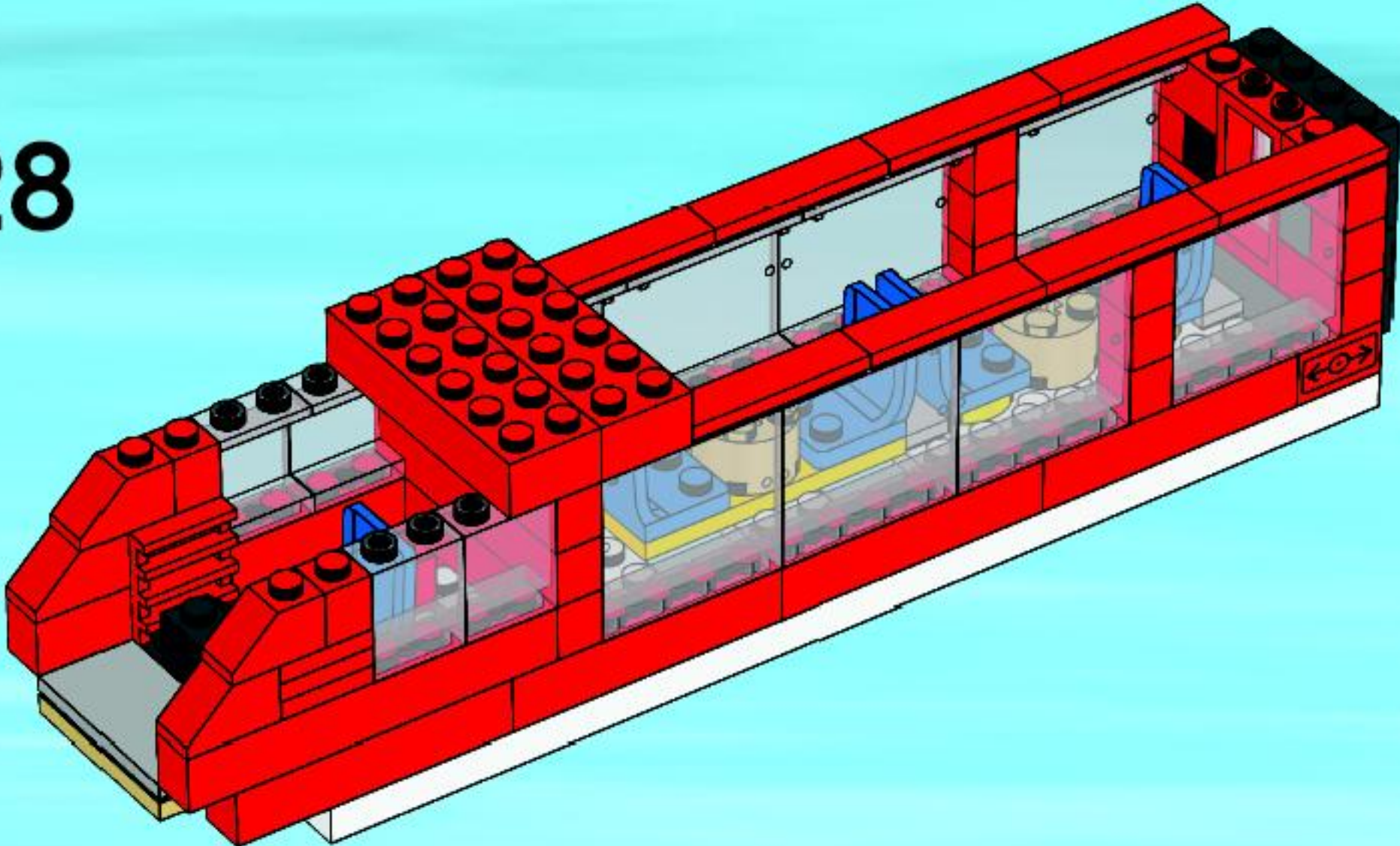

29

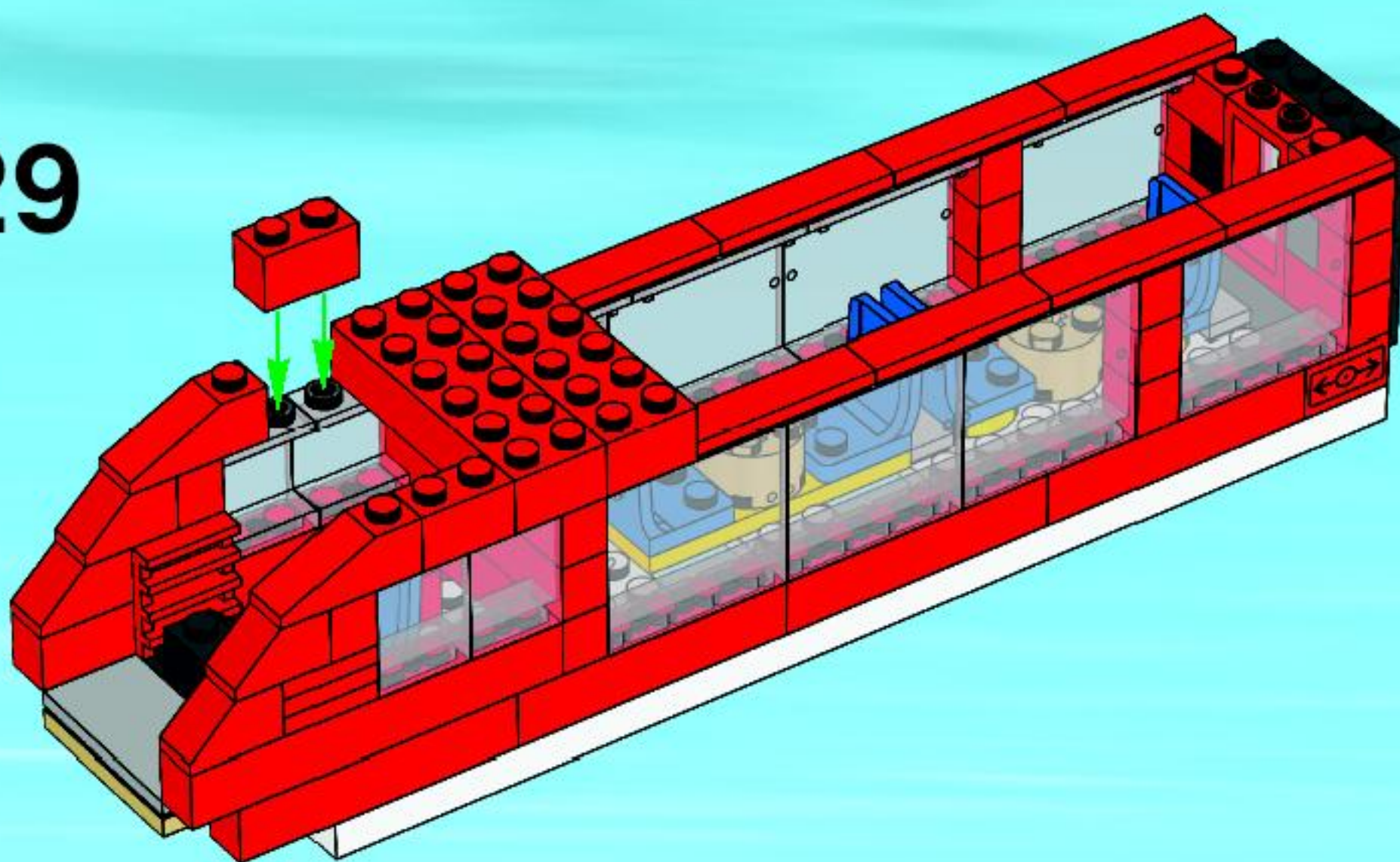



+

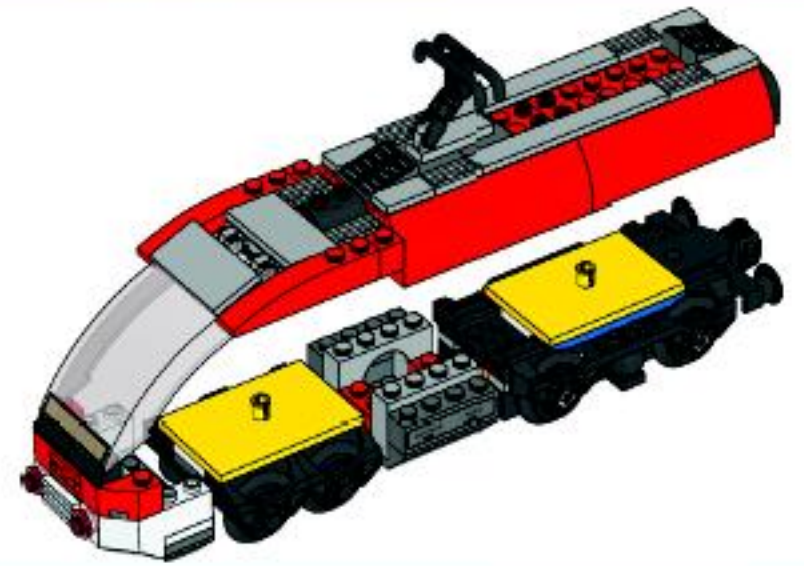

1



2

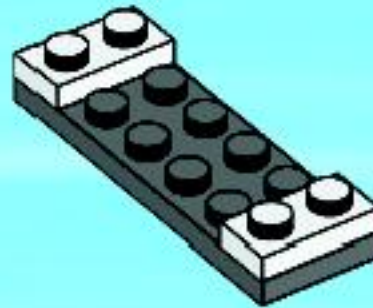

3

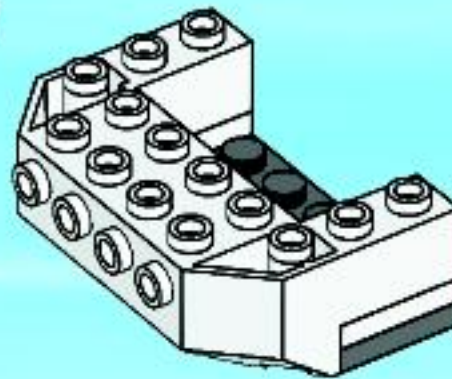

4

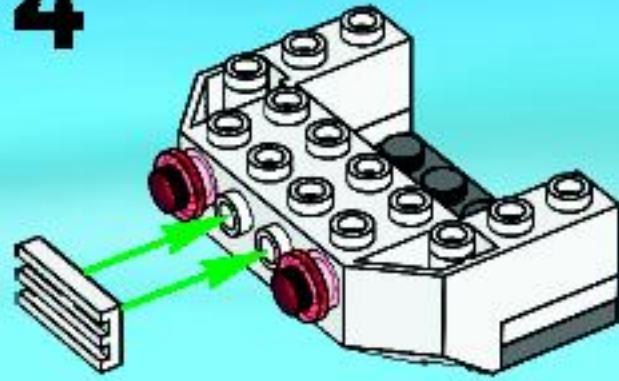

5

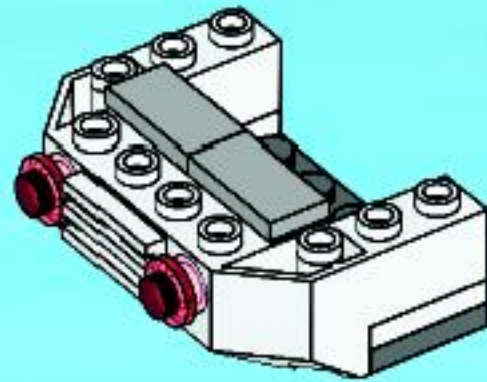

6

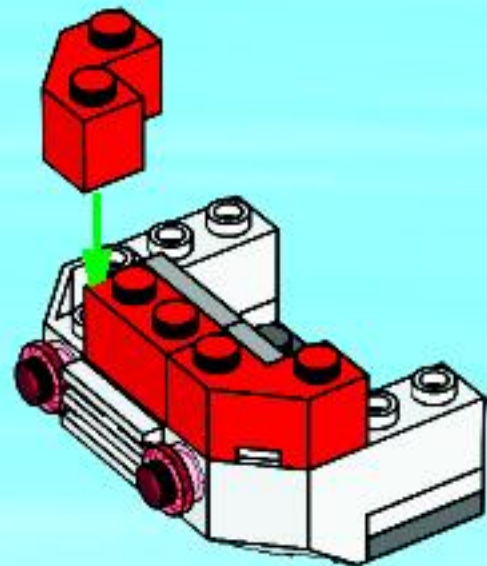

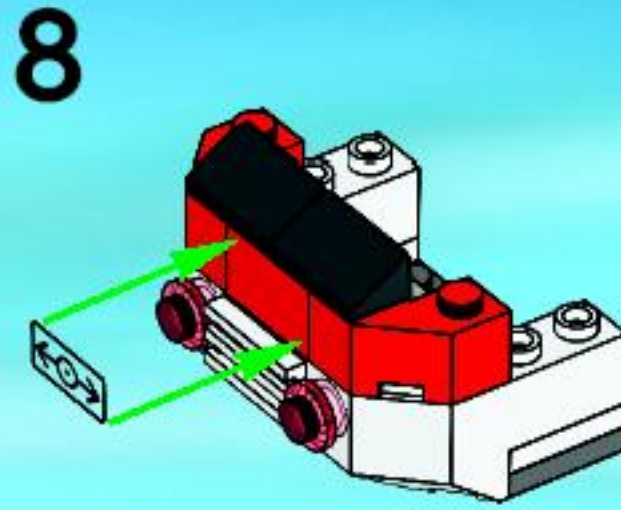
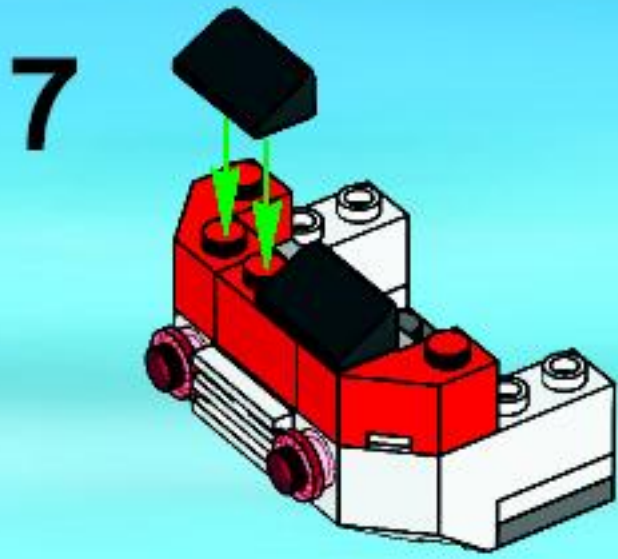

30

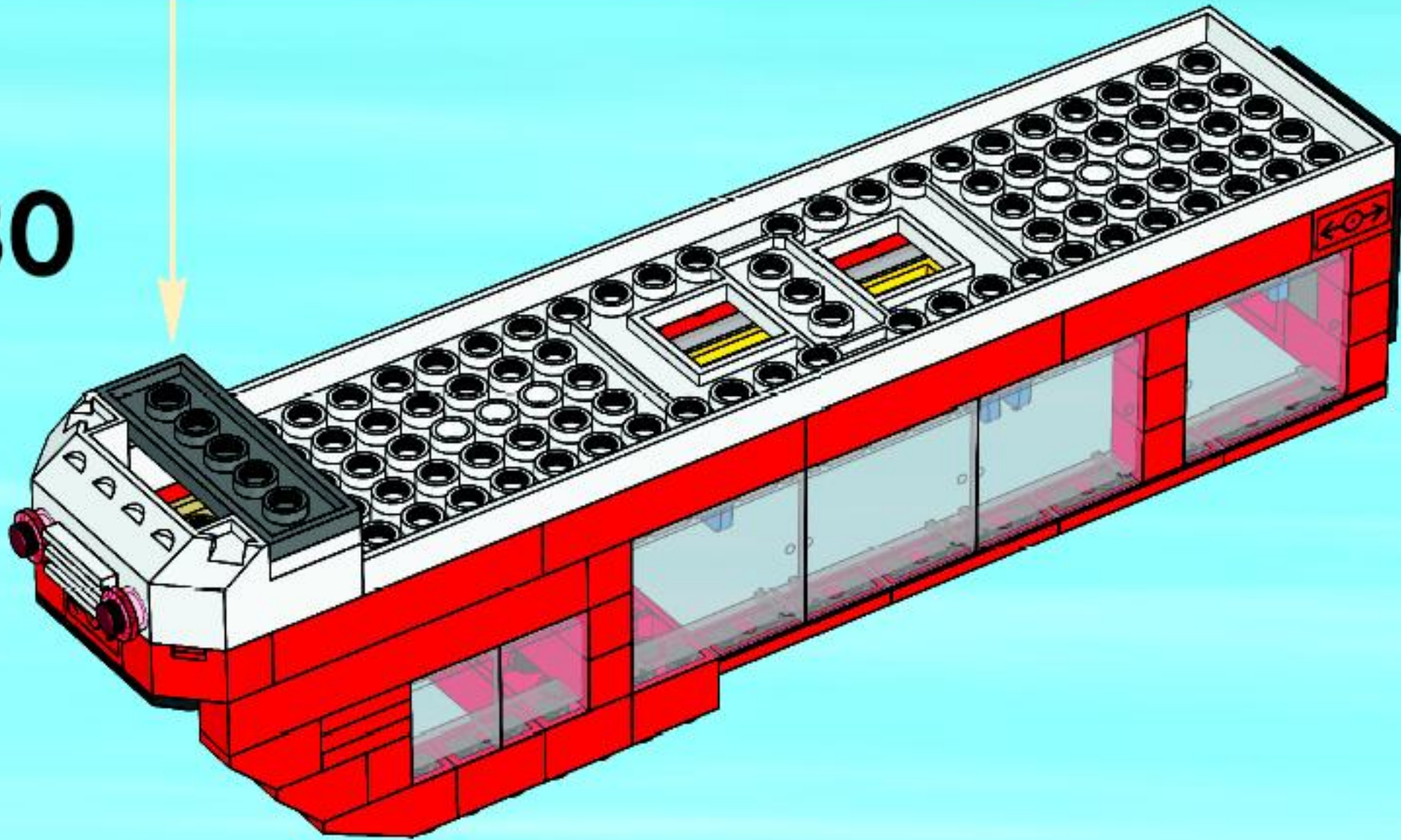

31

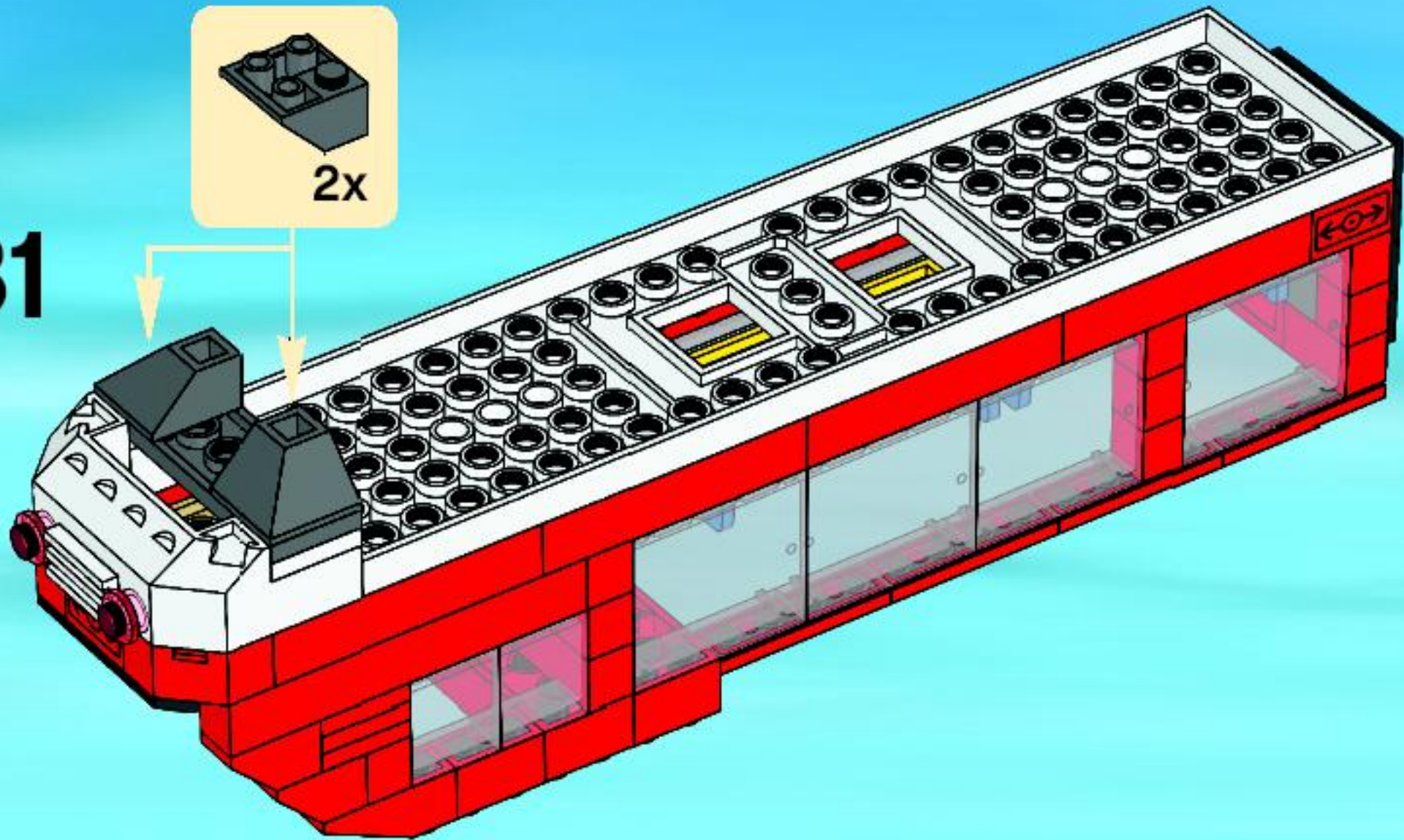

32

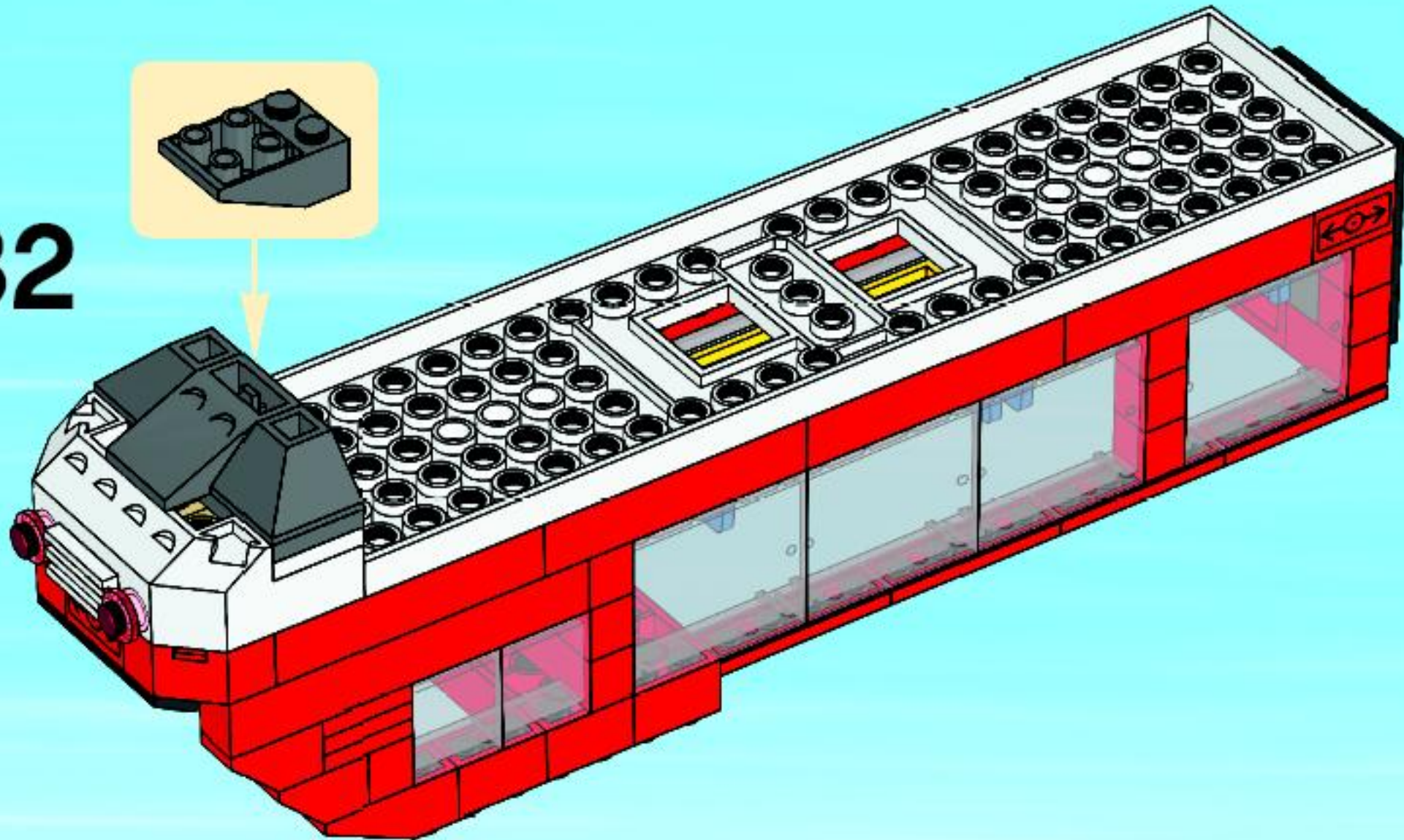



1

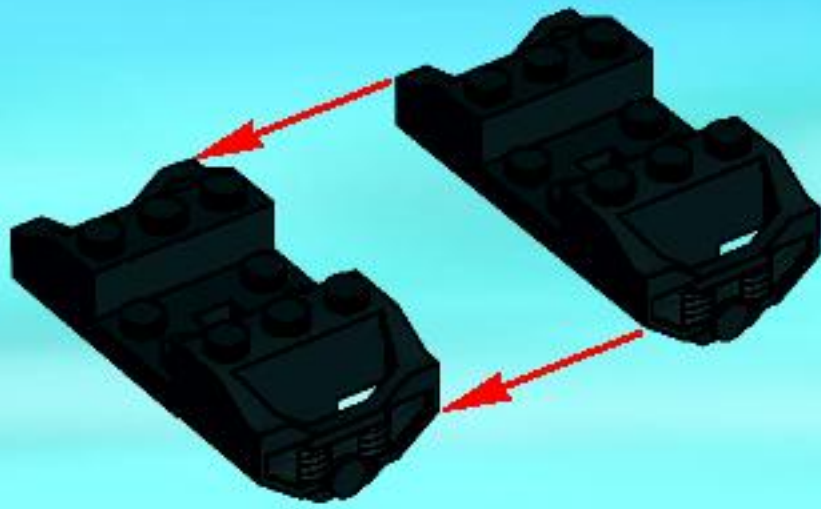

2



3



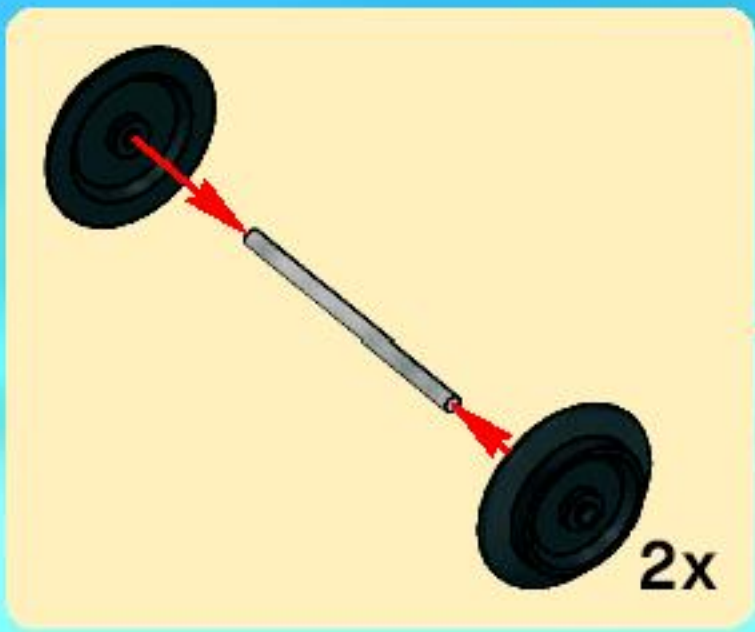

4

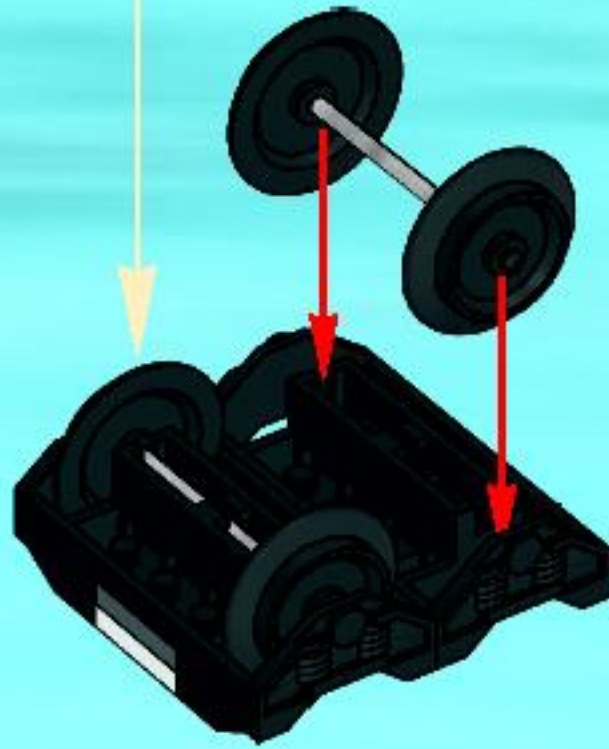

5



33

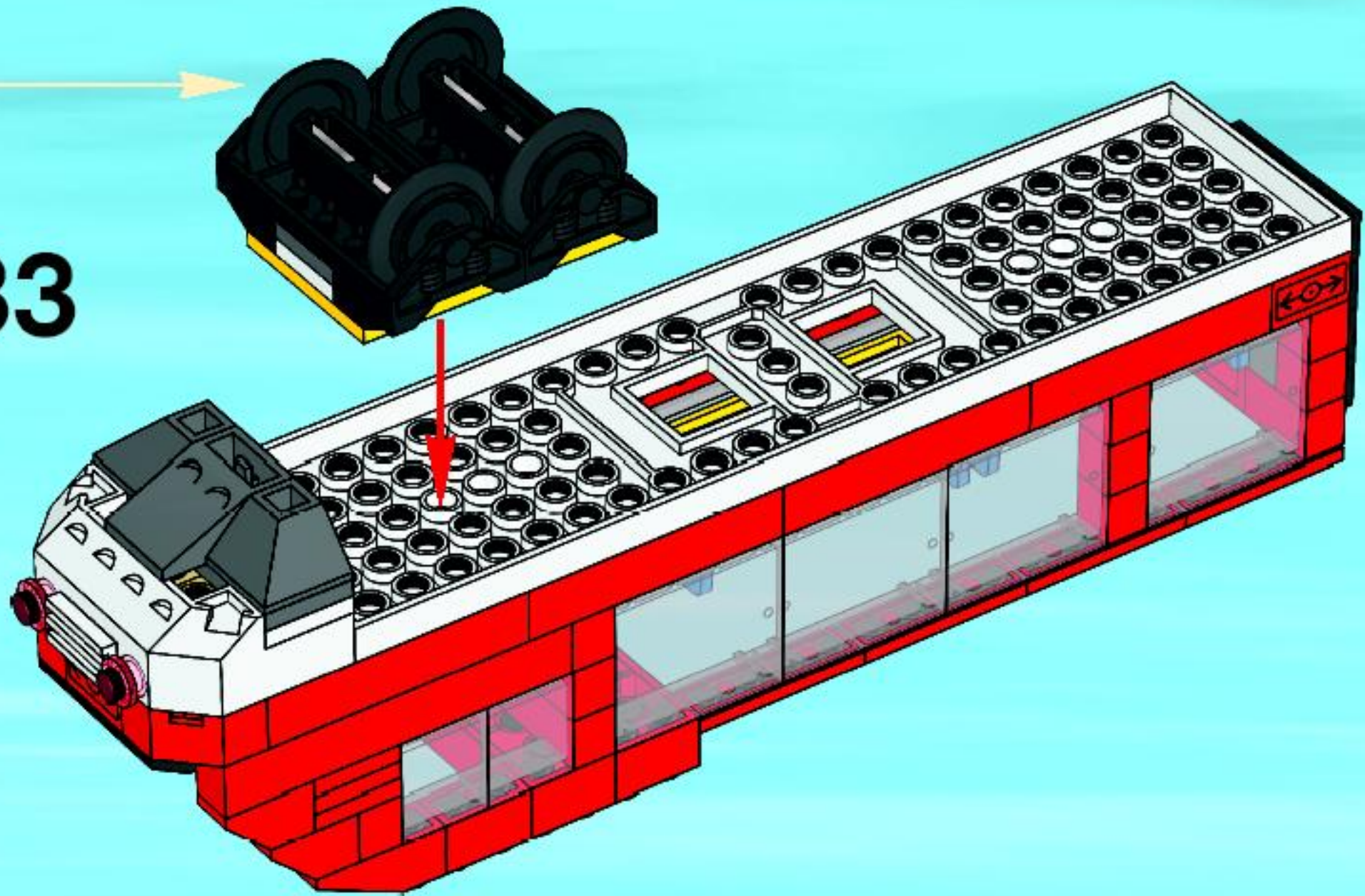



1

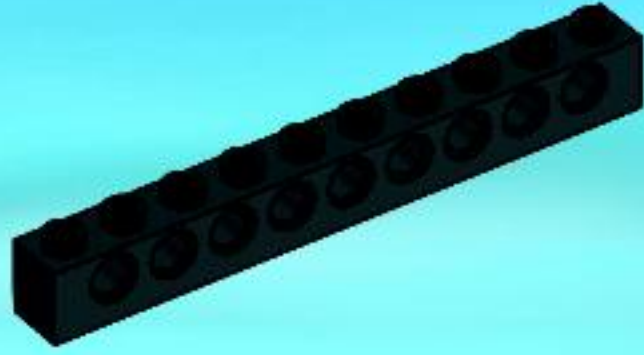

2

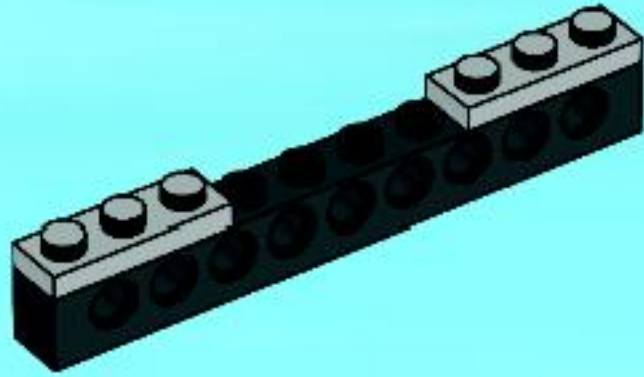

3

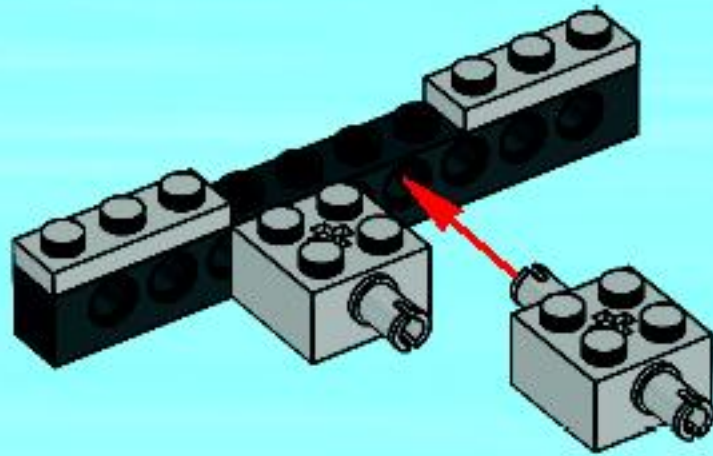

4

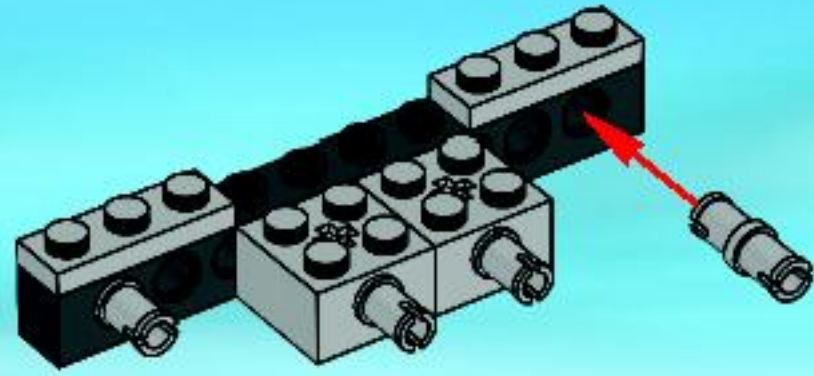

5

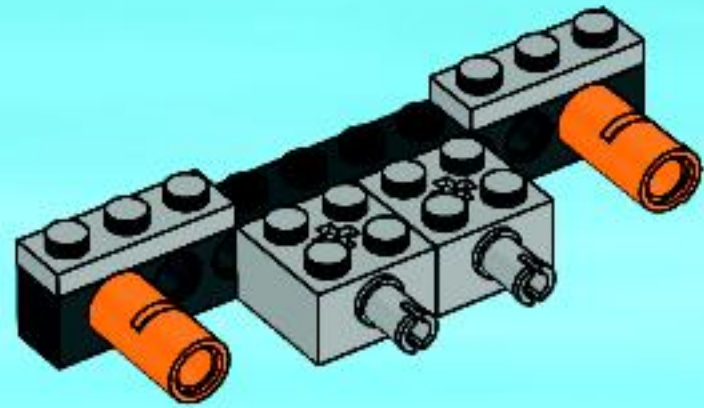

6

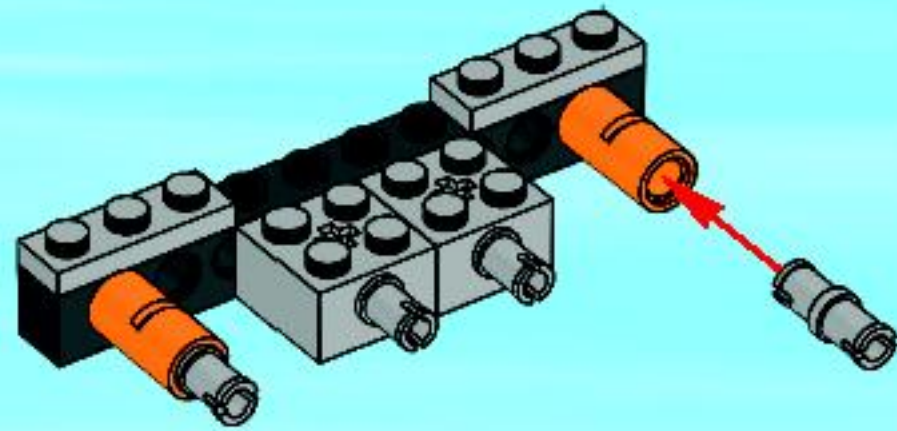

7

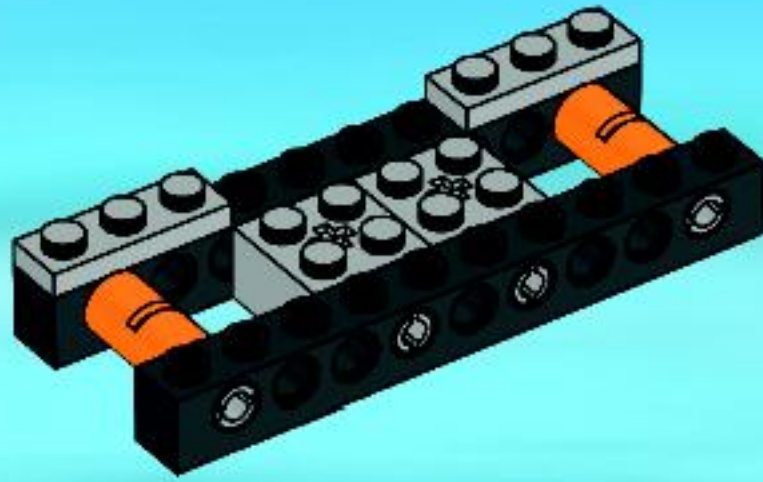

8

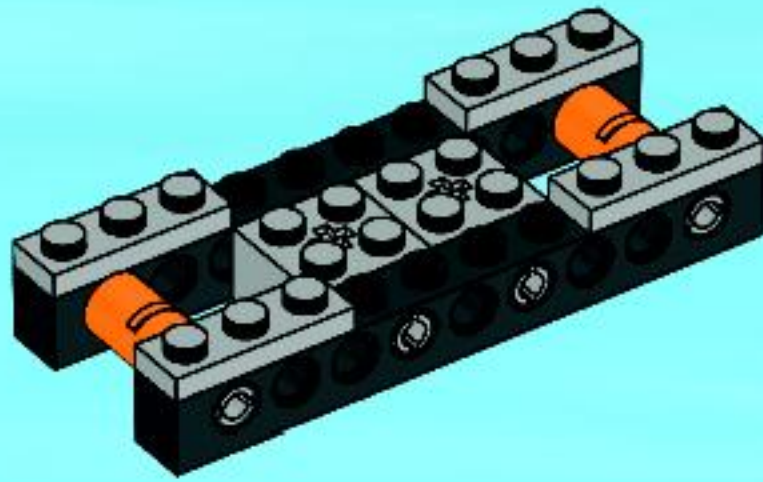

9

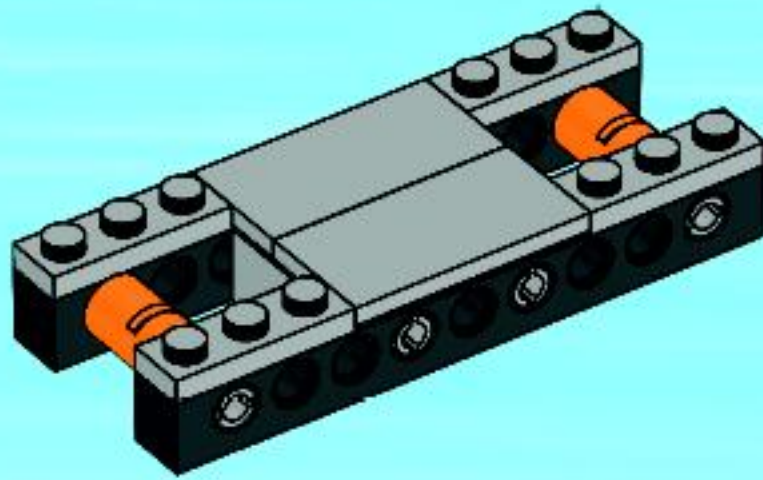

10



11

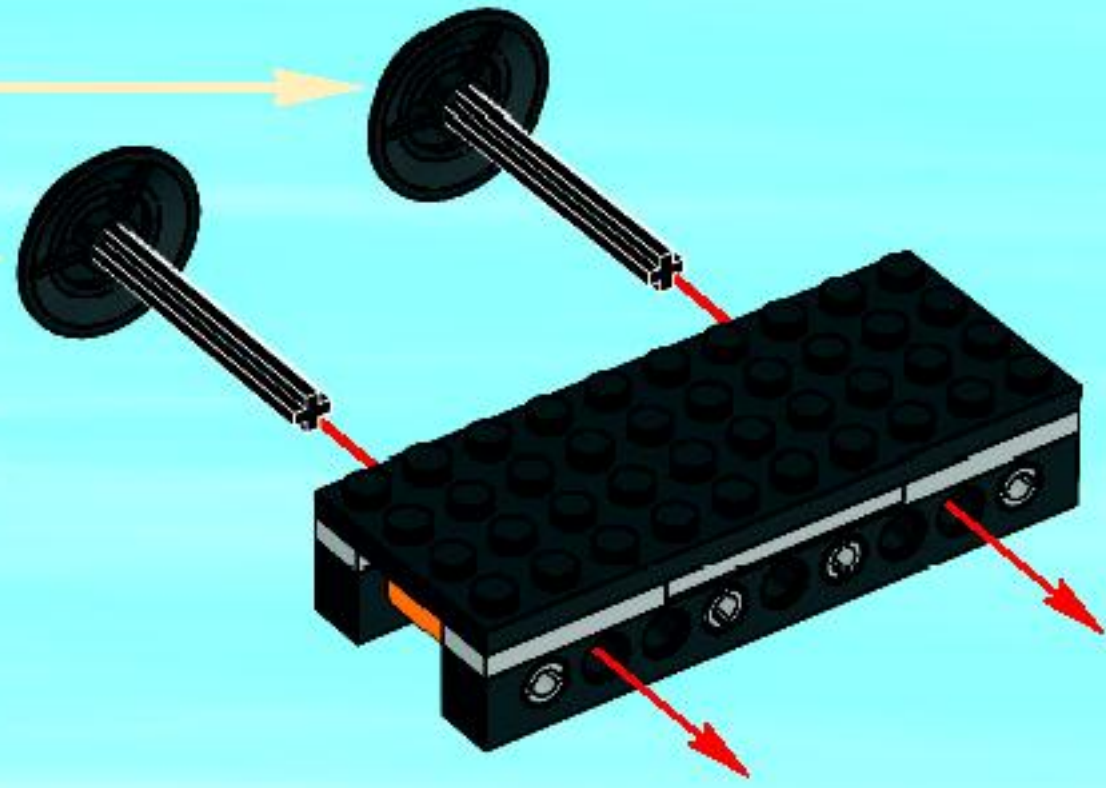

1 

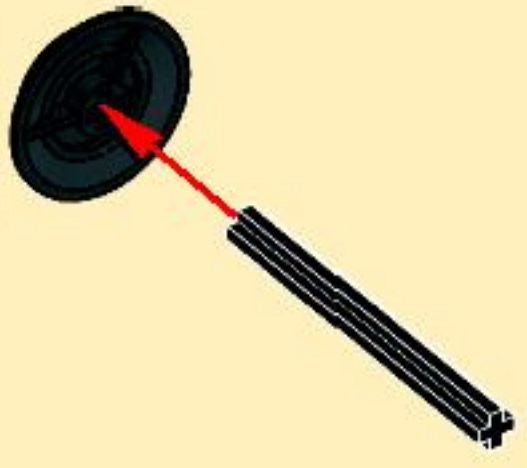
2  2x

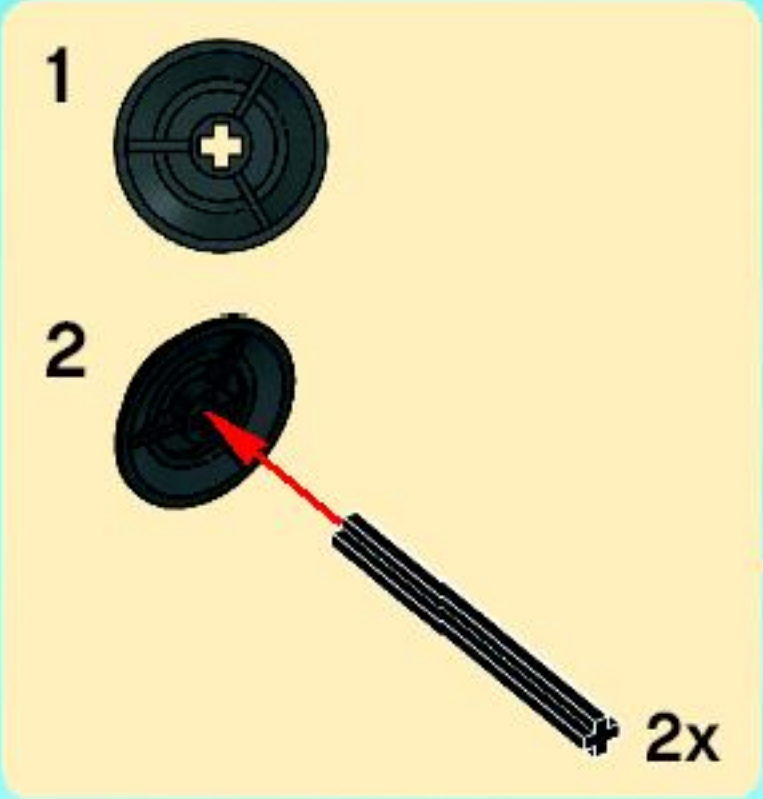
A yellow callout box with rounded corners. It contains two numbered steps. Step 1 shows a black Technic bush. Step 2 shows a black Technic axle with a bush on its end, with a red arrow pointing to the bush. The text '2x' is at the bottom right of the callout.

12

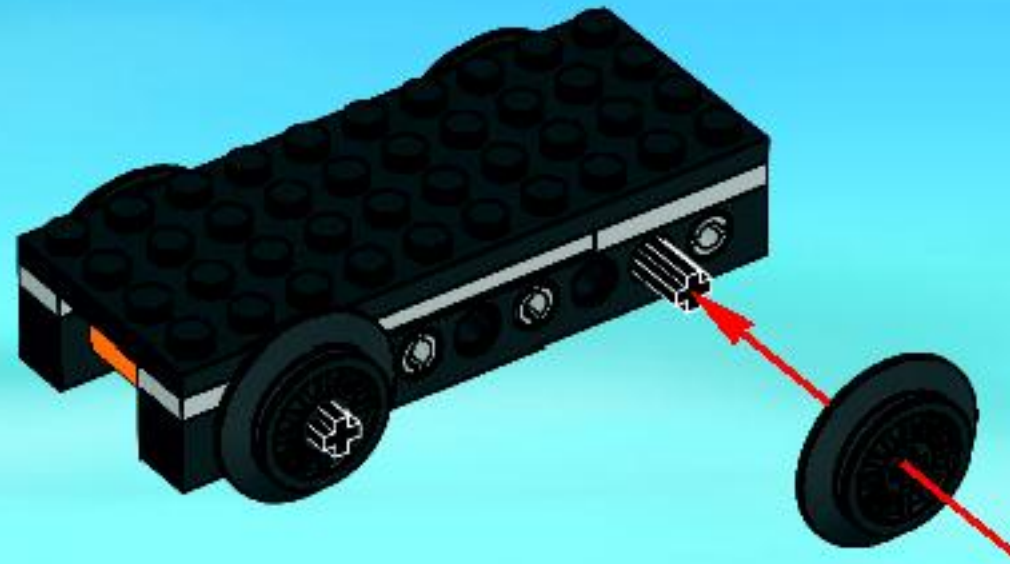

13

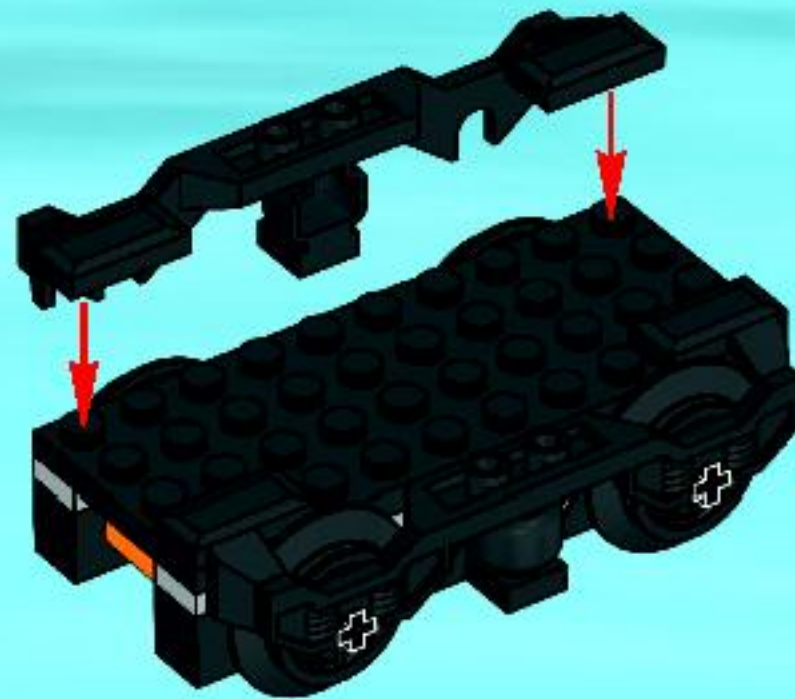

14

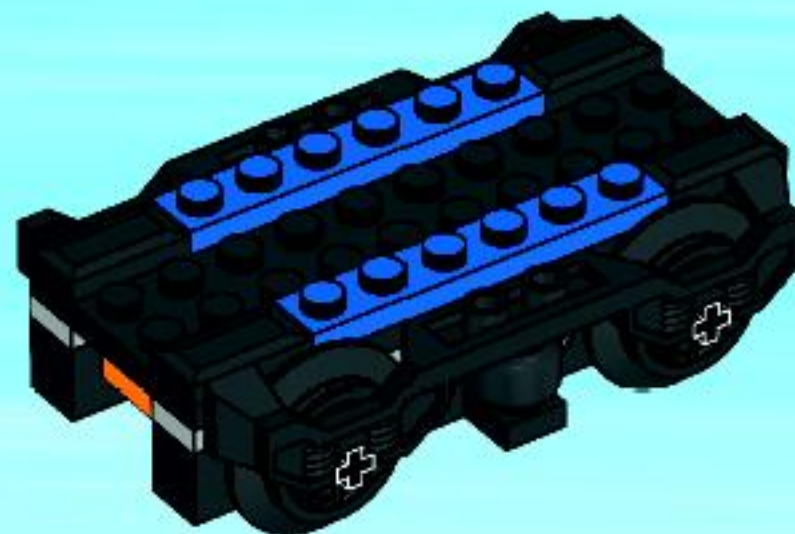

15

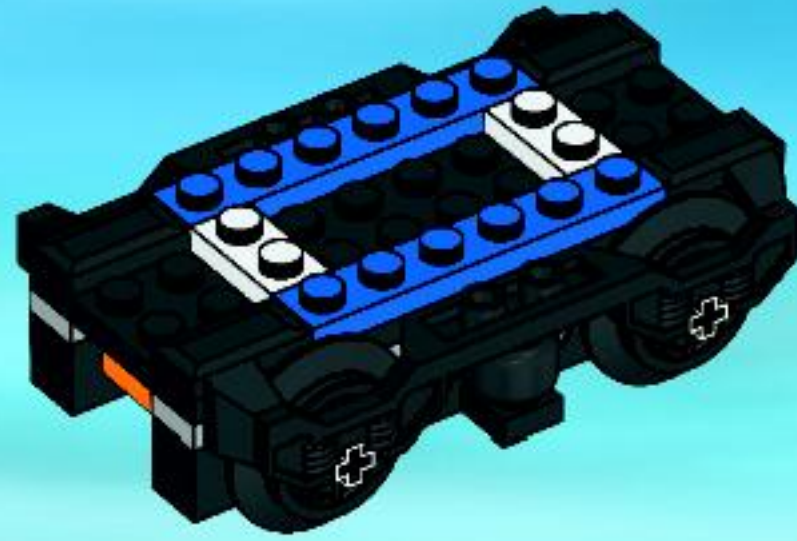

16

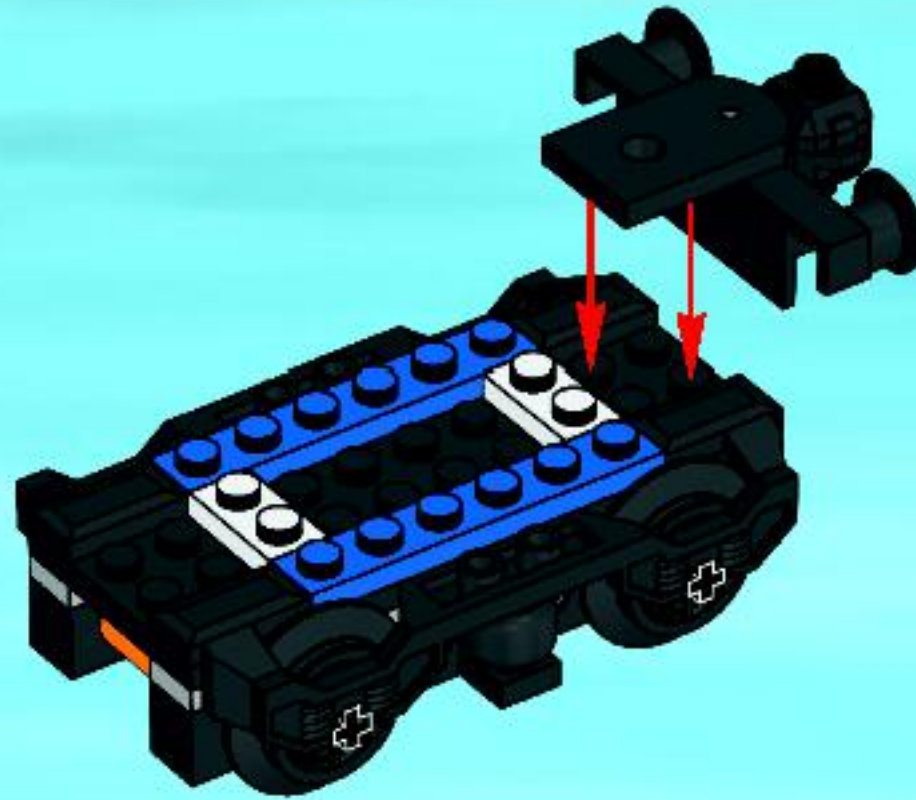

17

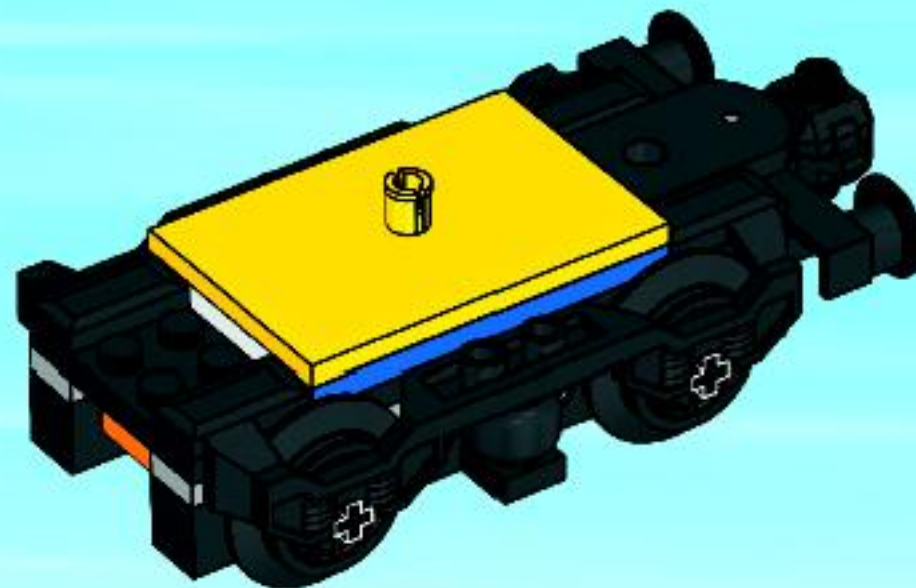

34

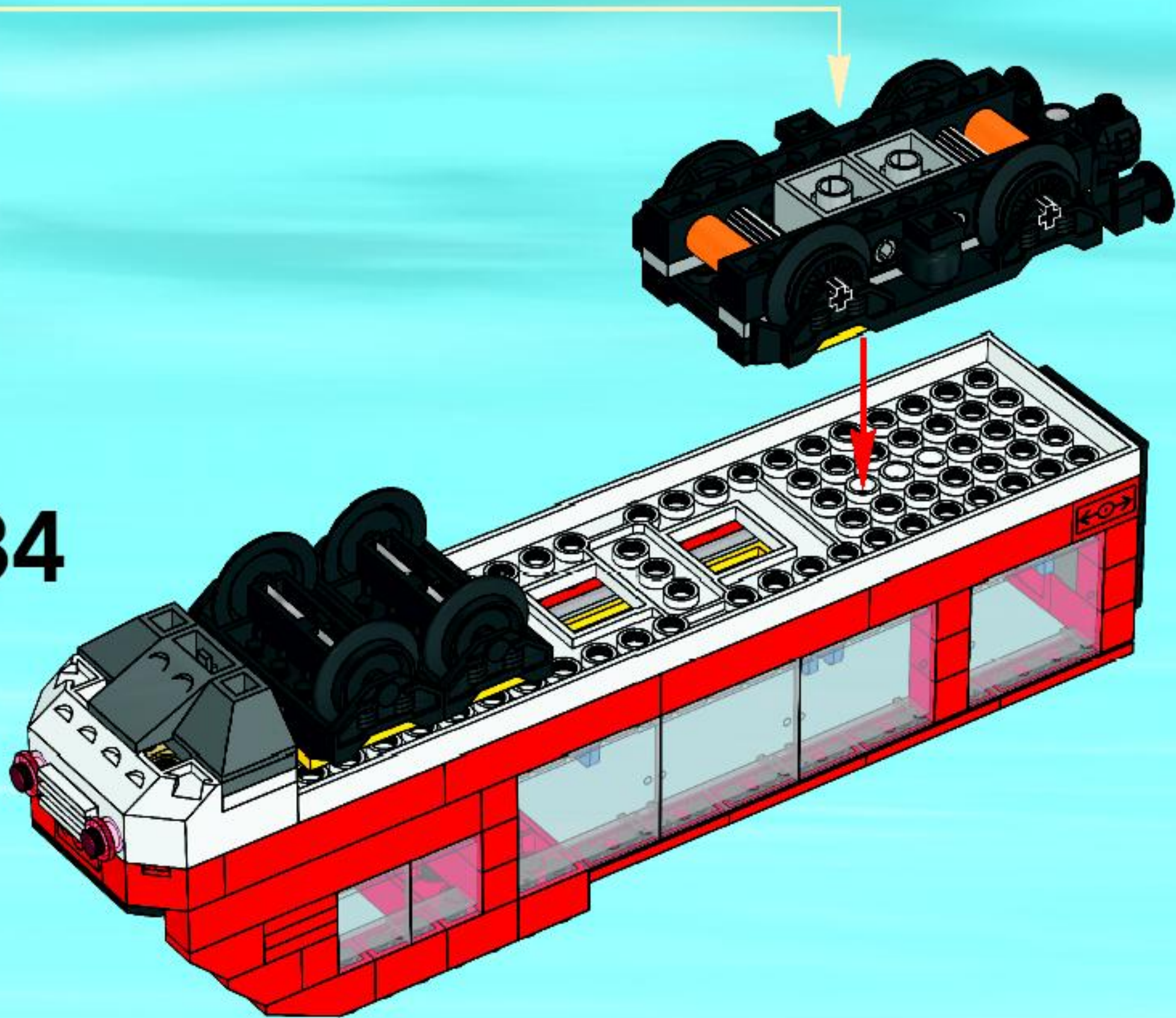

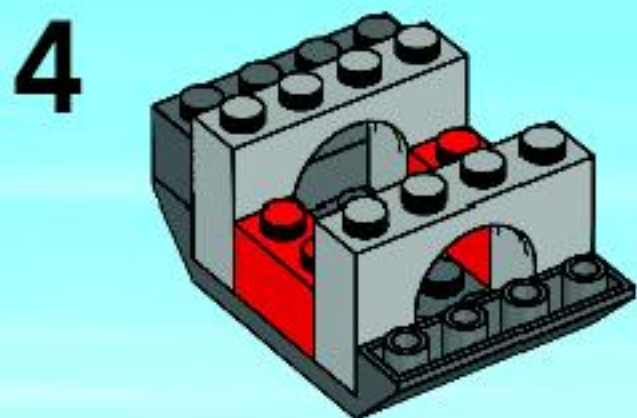
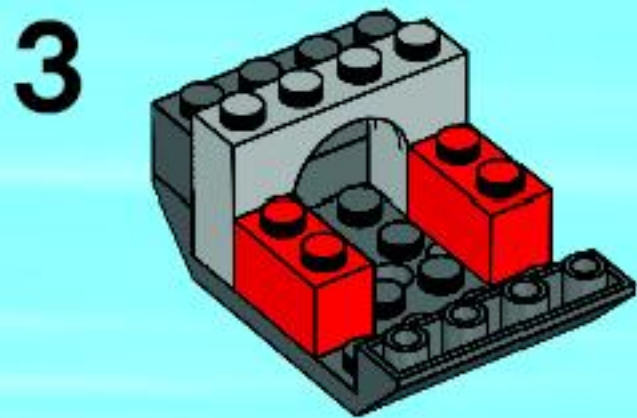
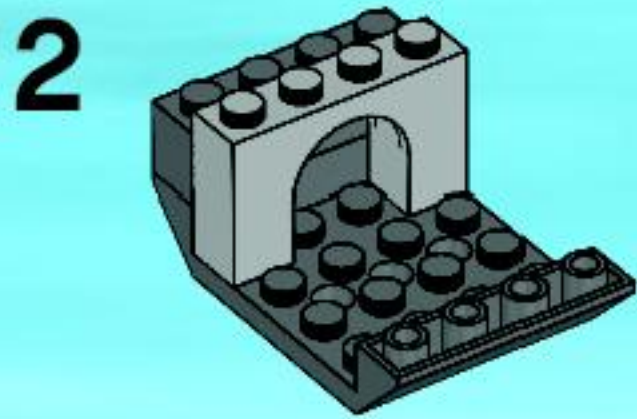
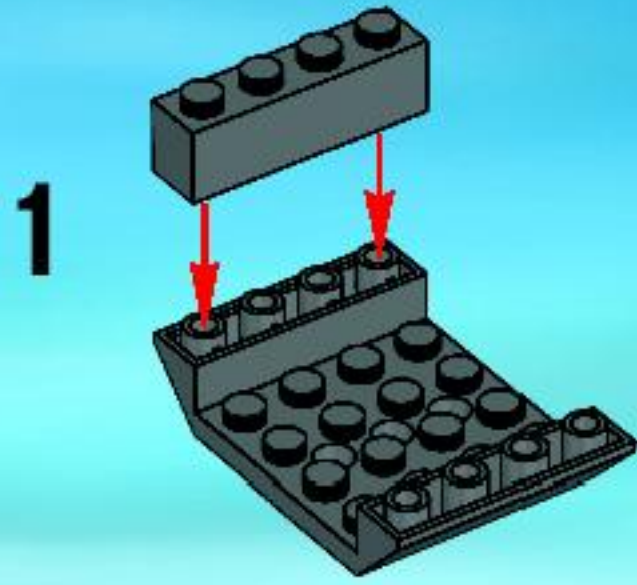
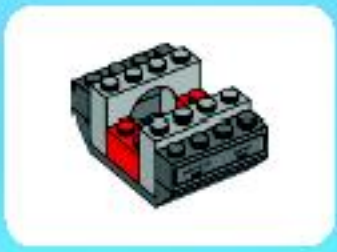

5

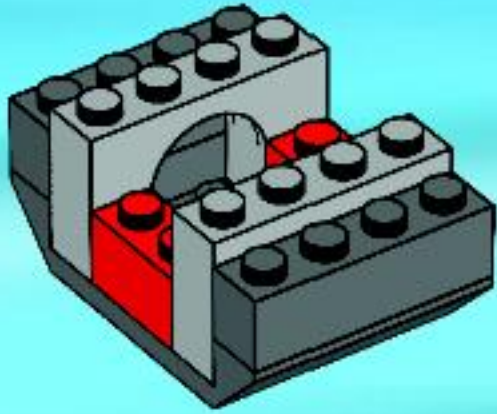

6

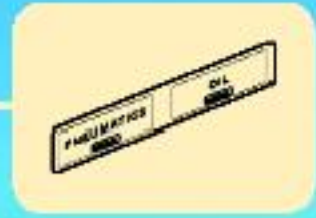
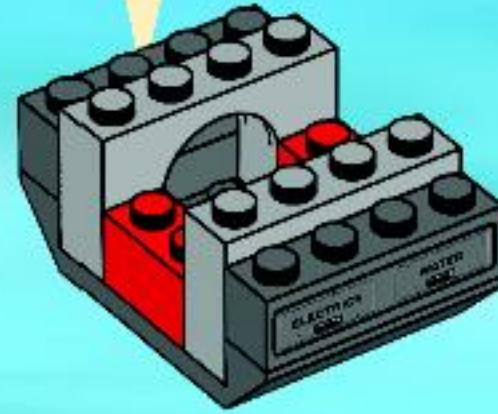

35

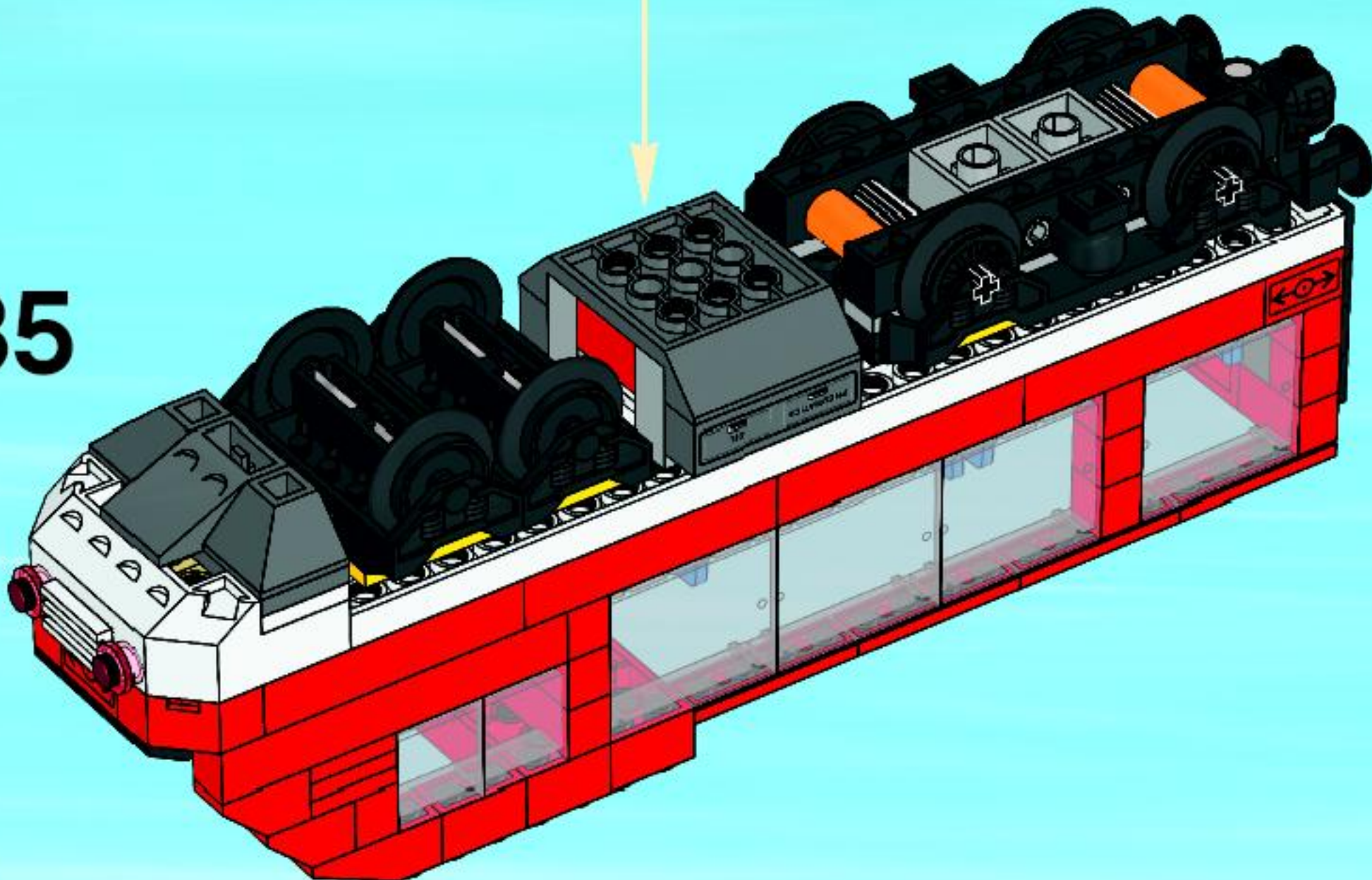

36

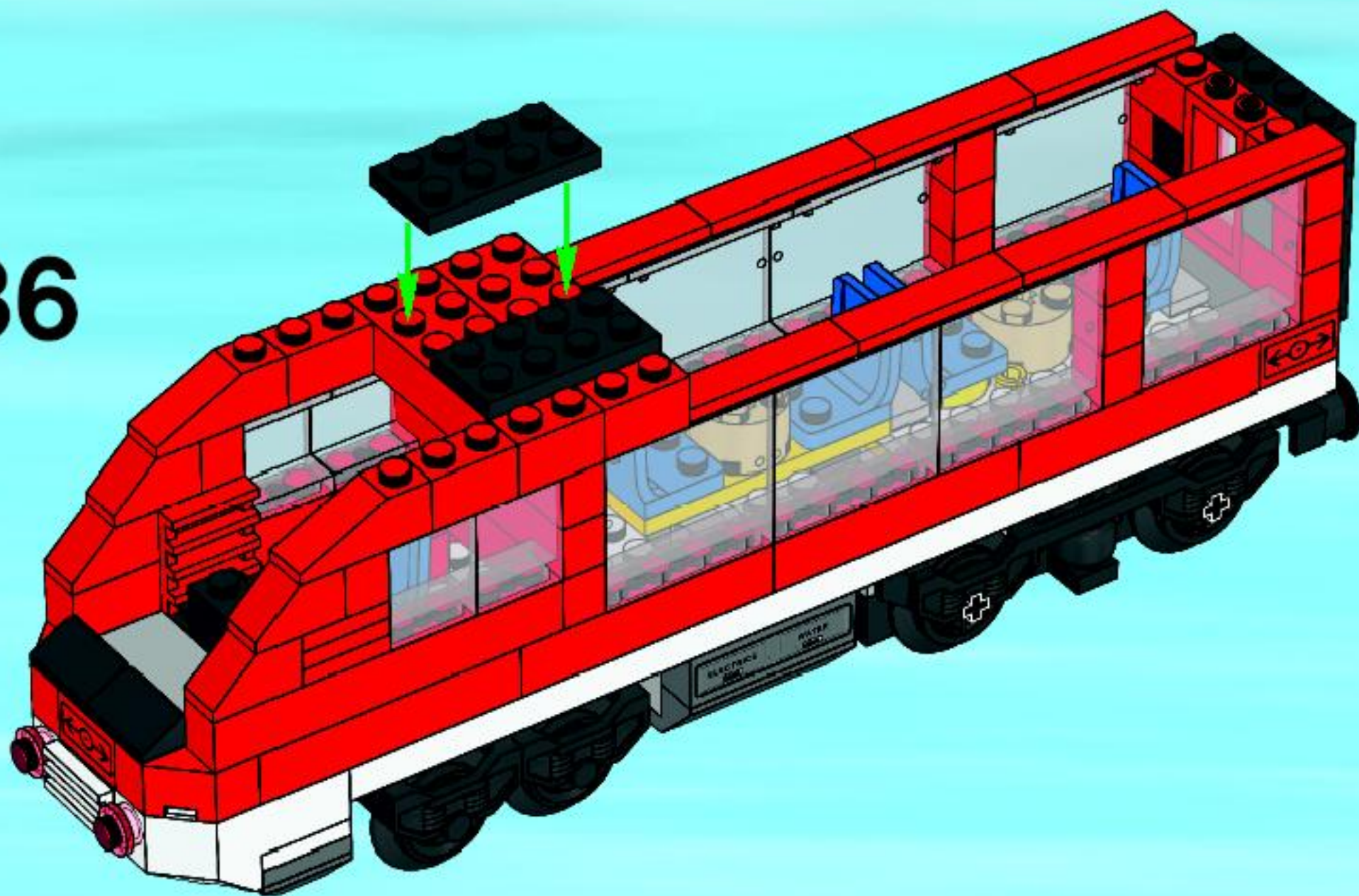

37

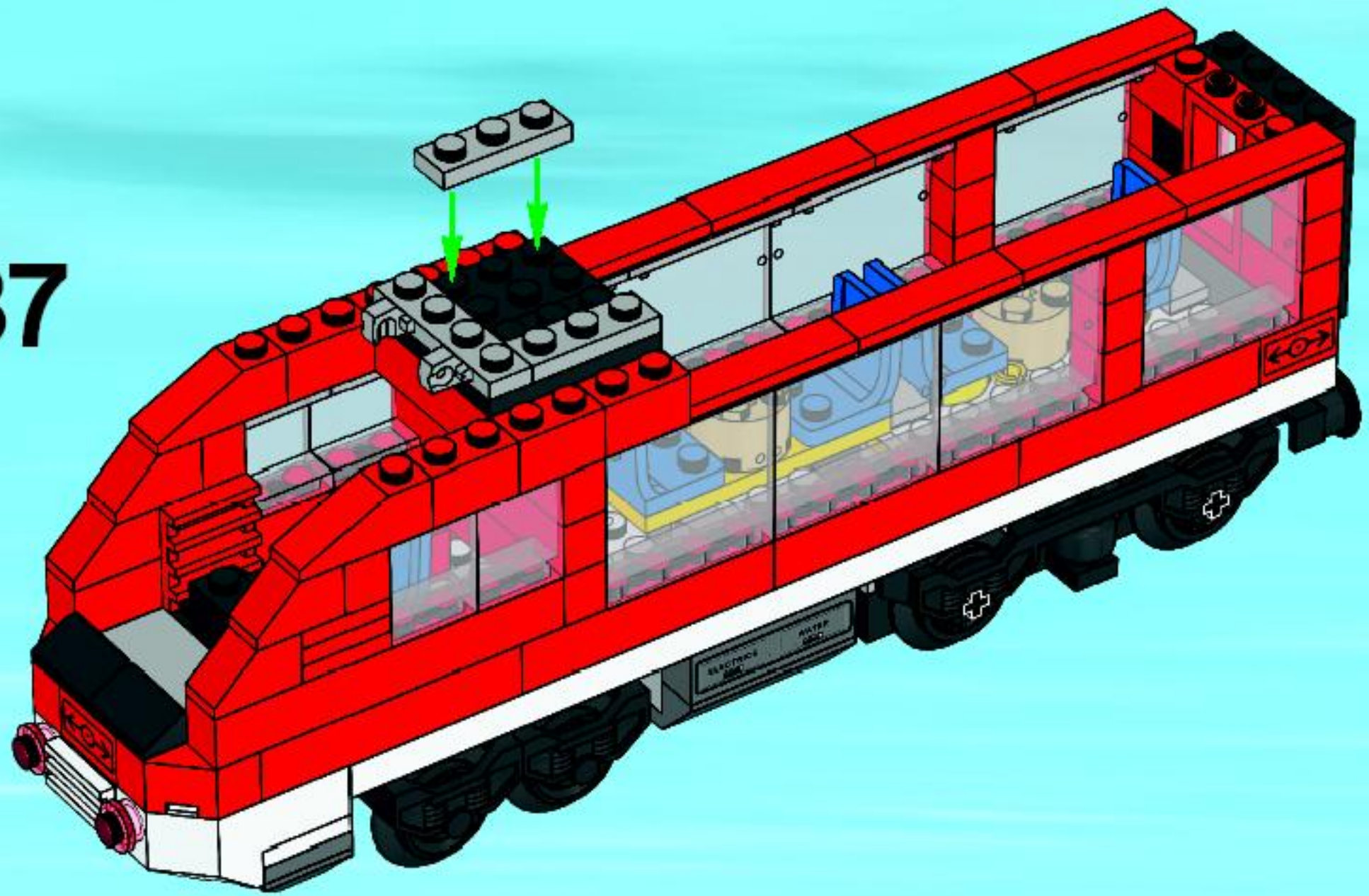

38

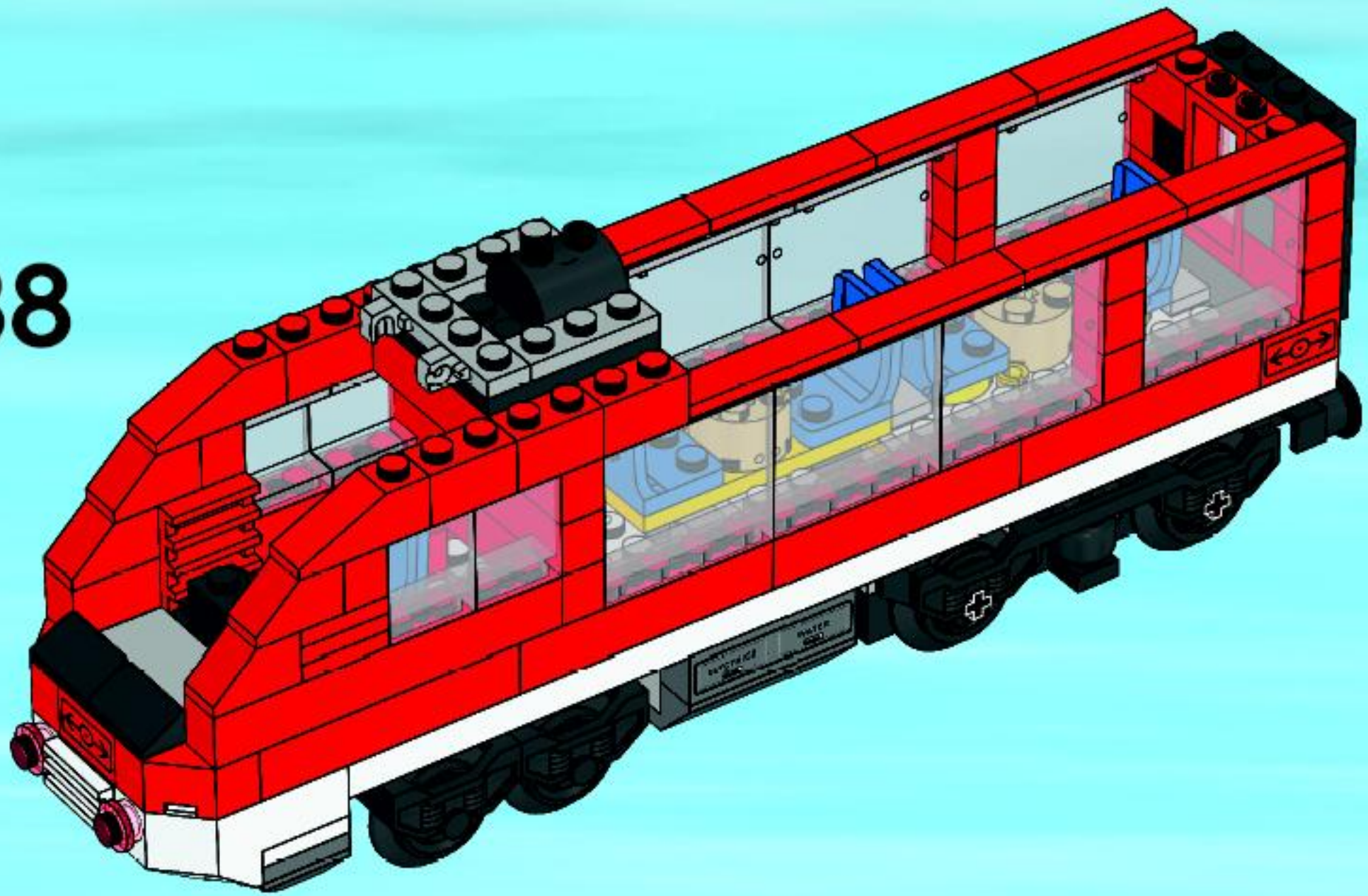

39

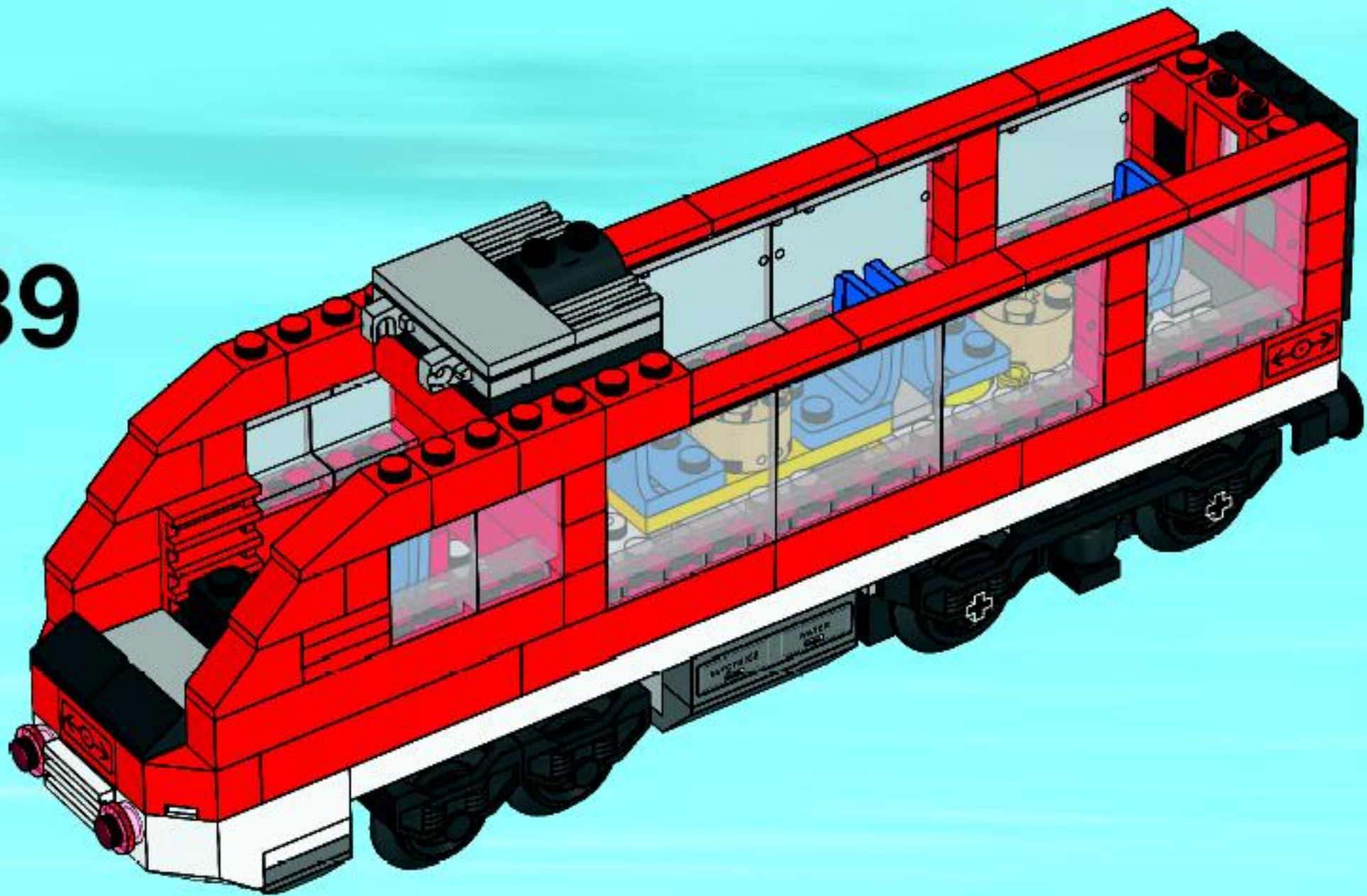

40

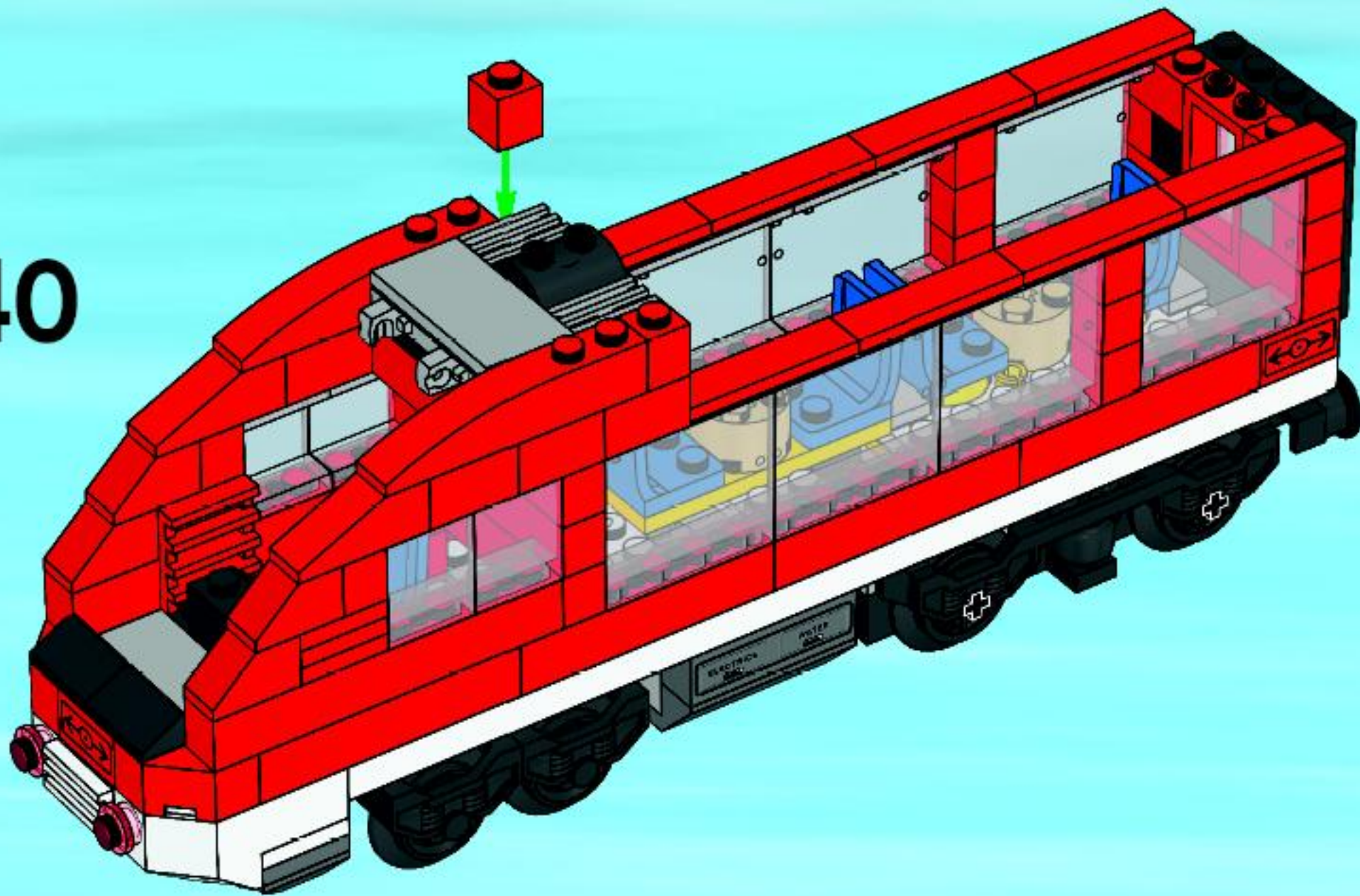

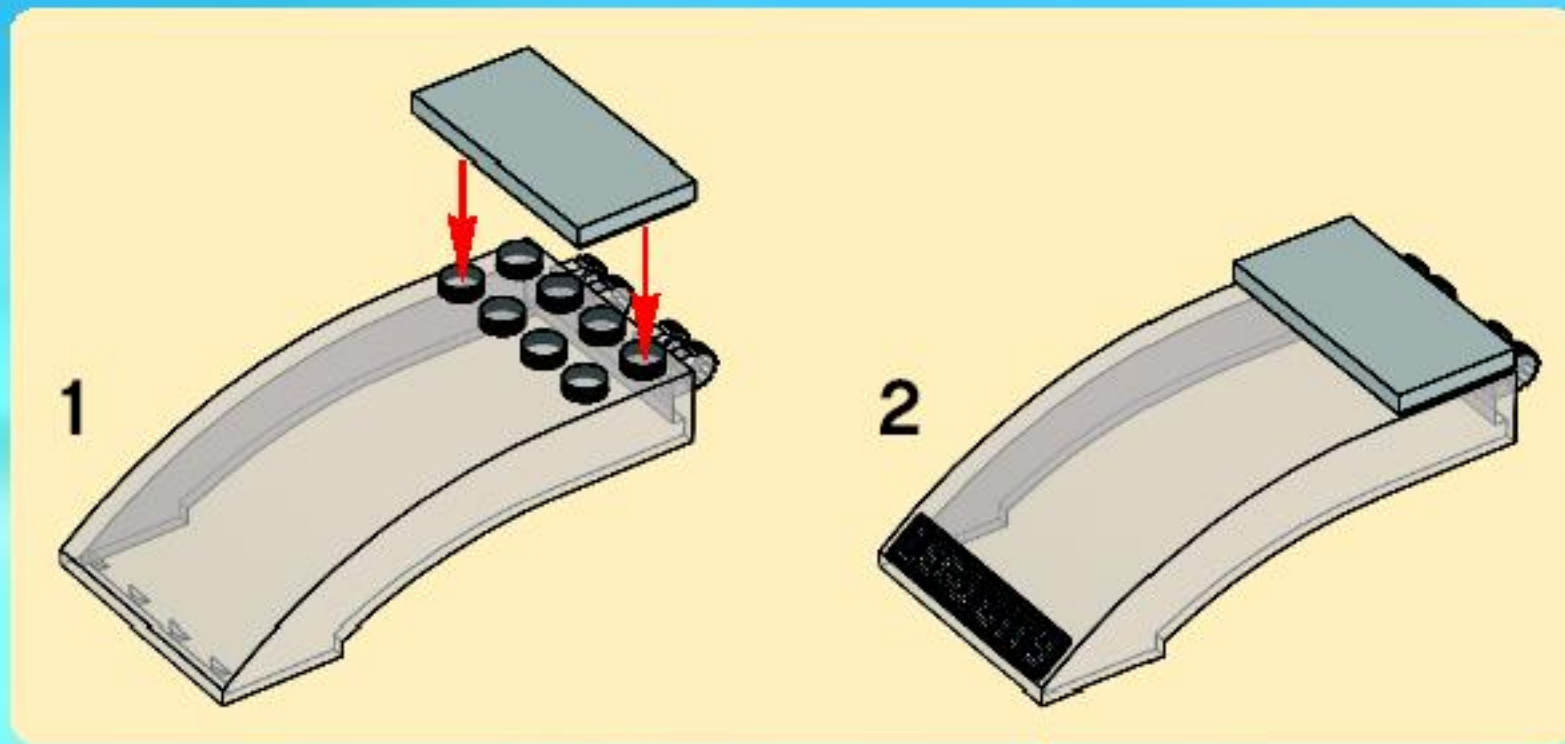

41

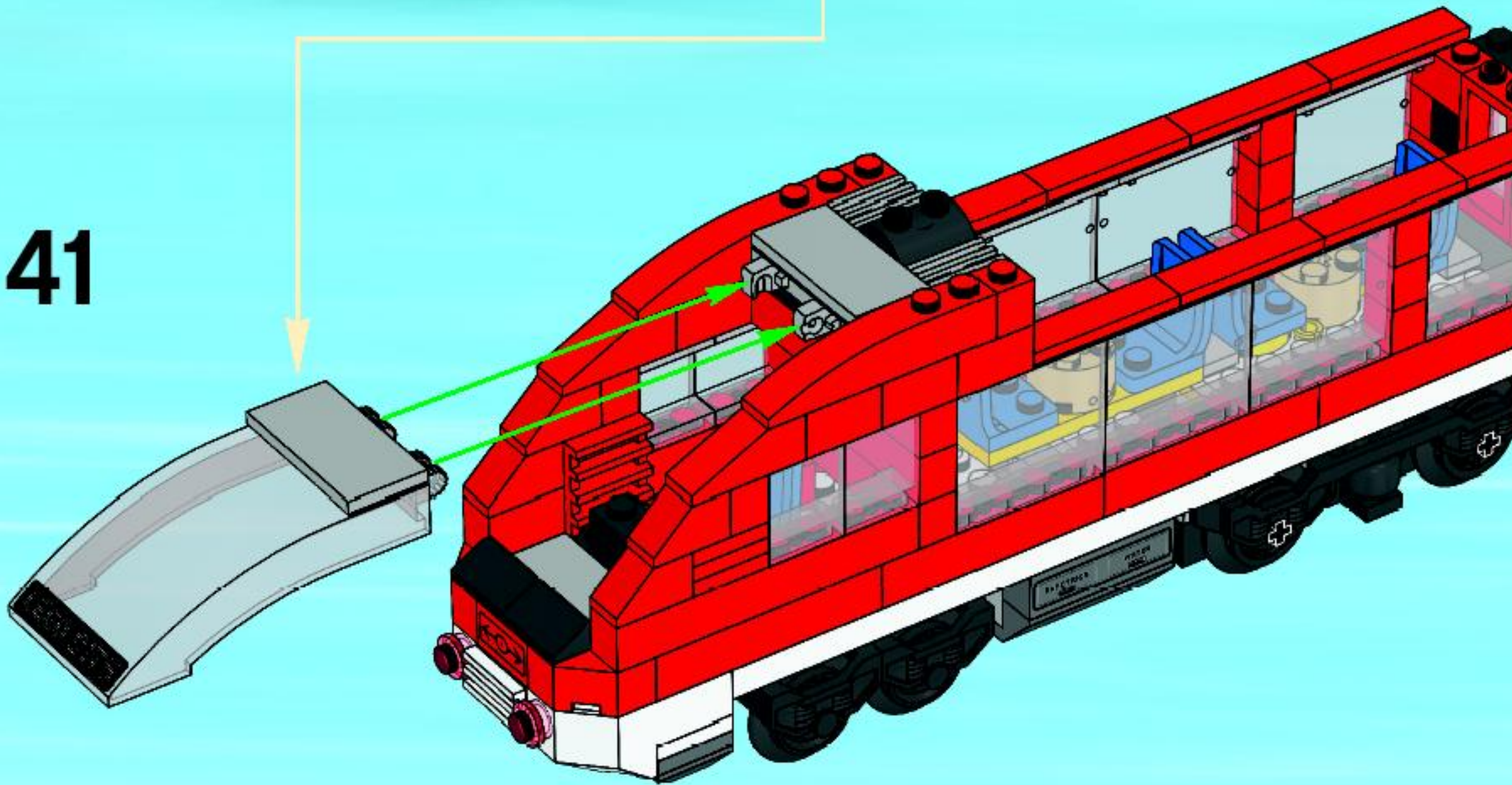

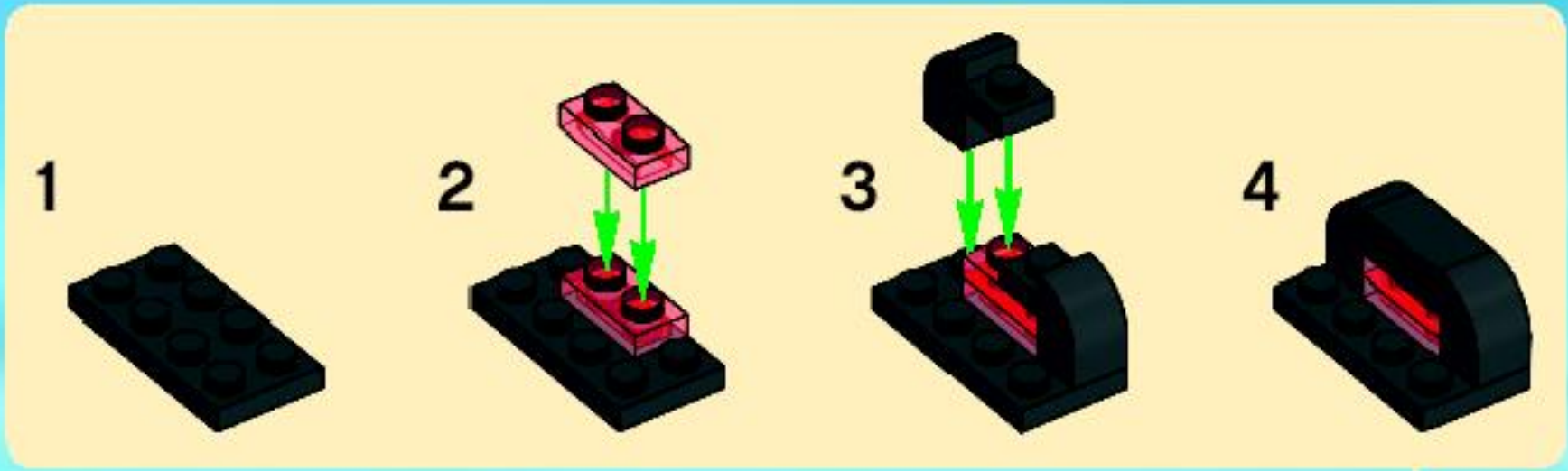

42

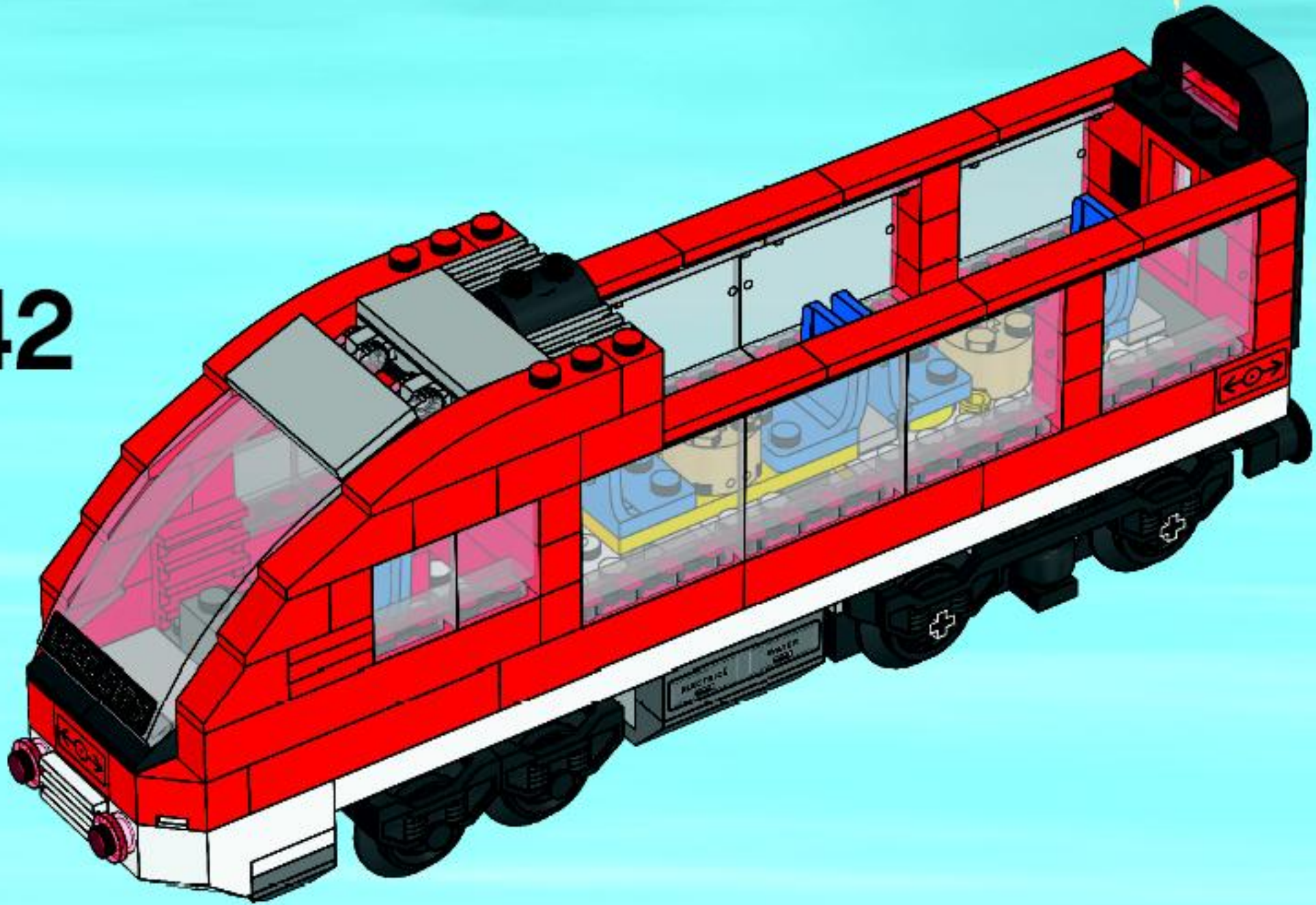

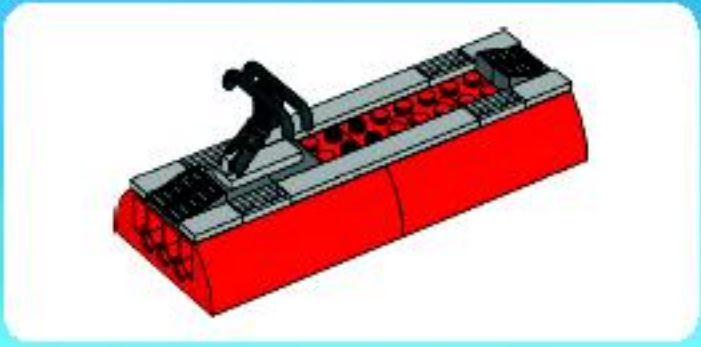

1

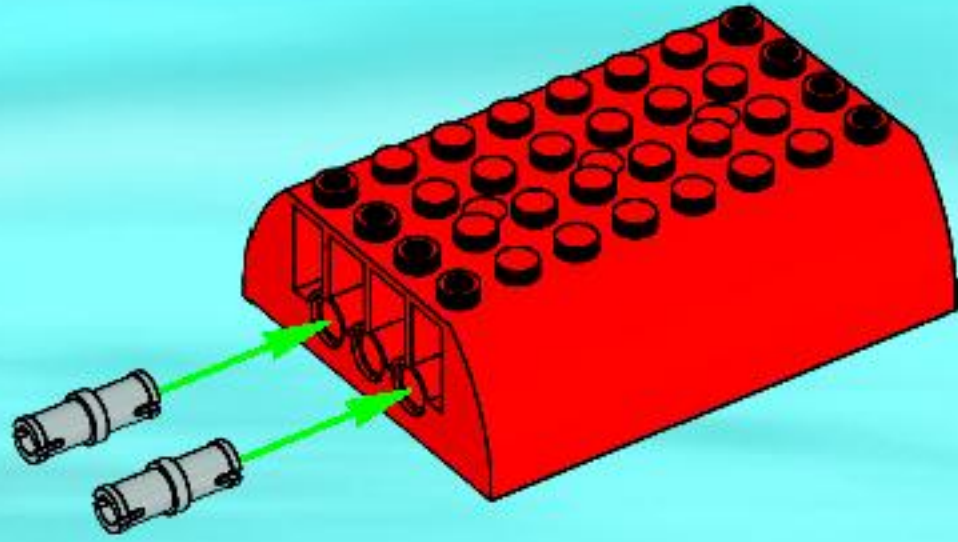

2

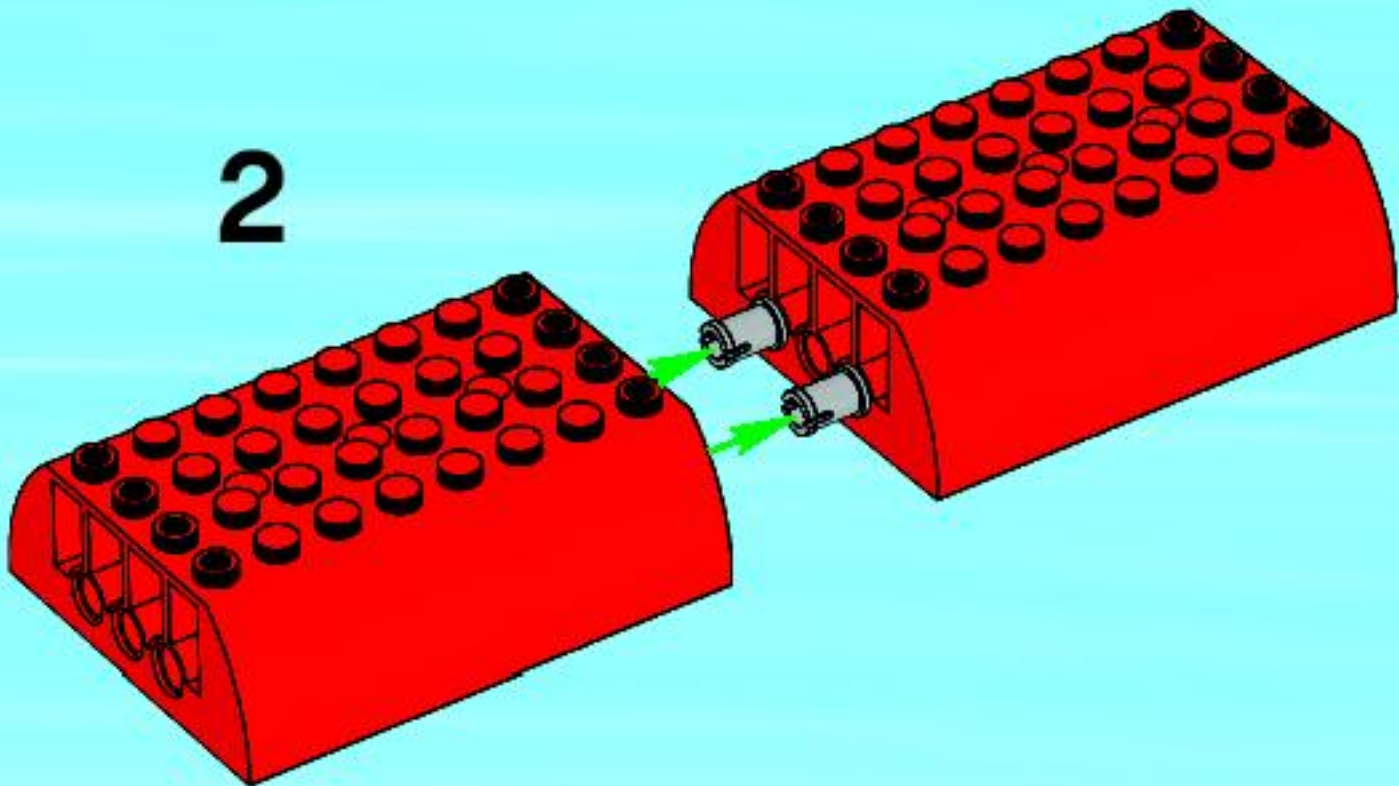

3

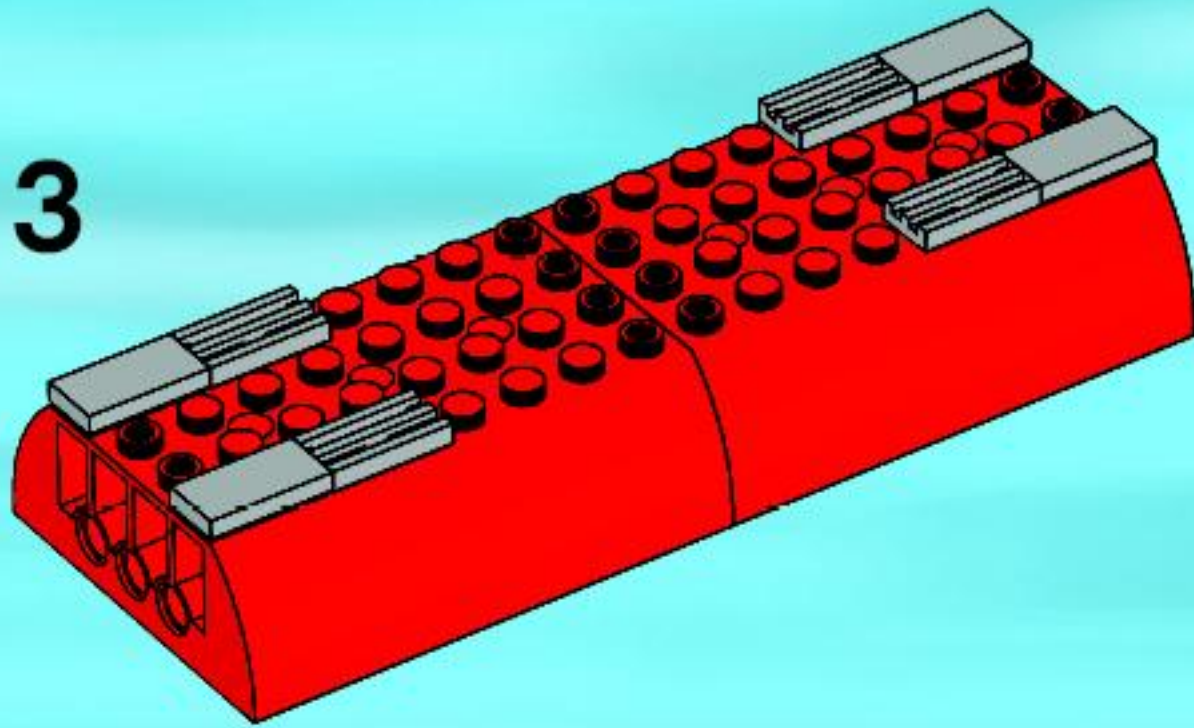

4

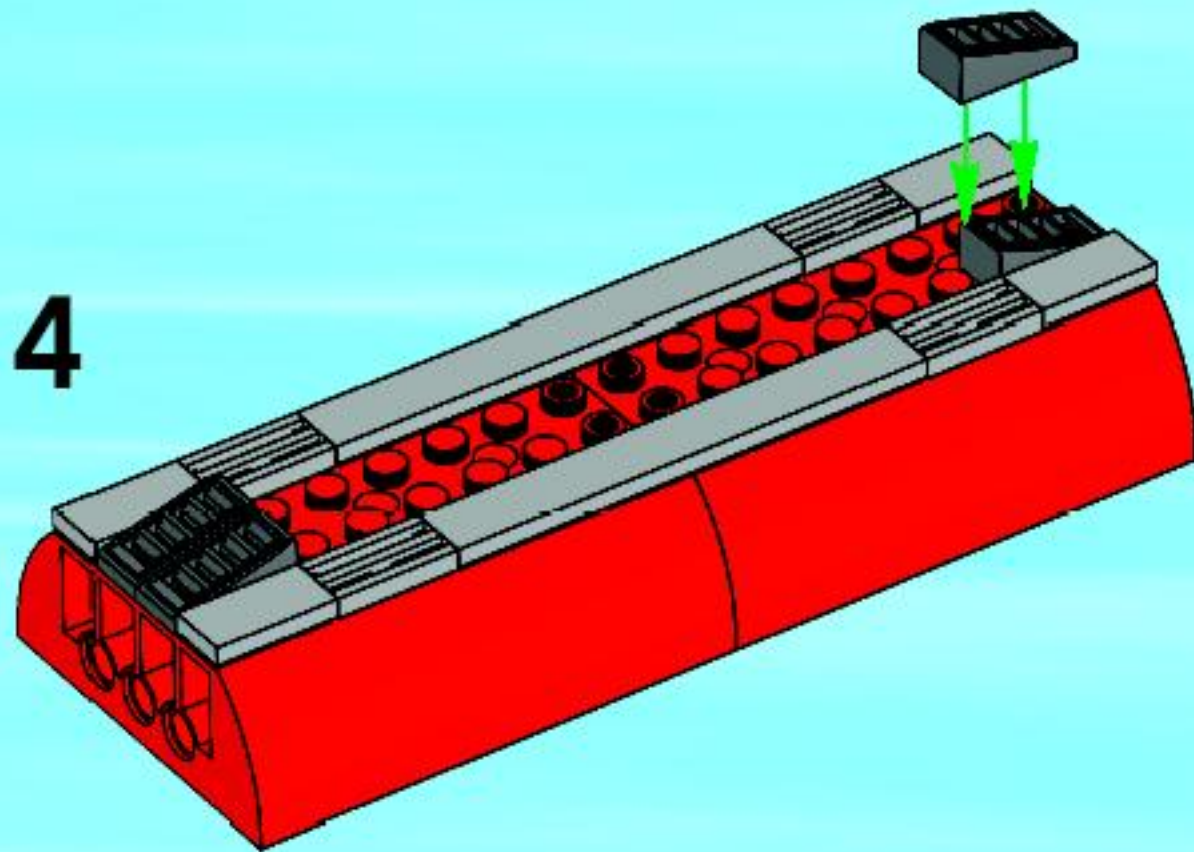

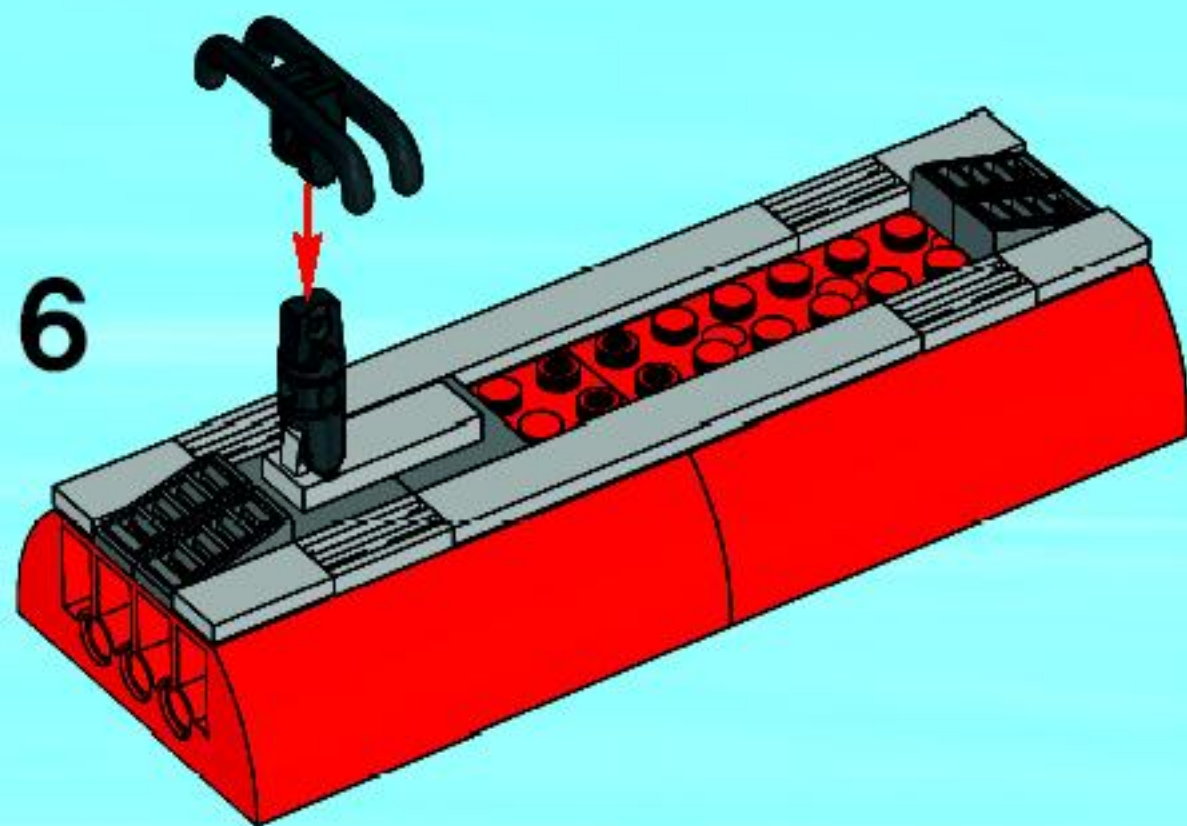
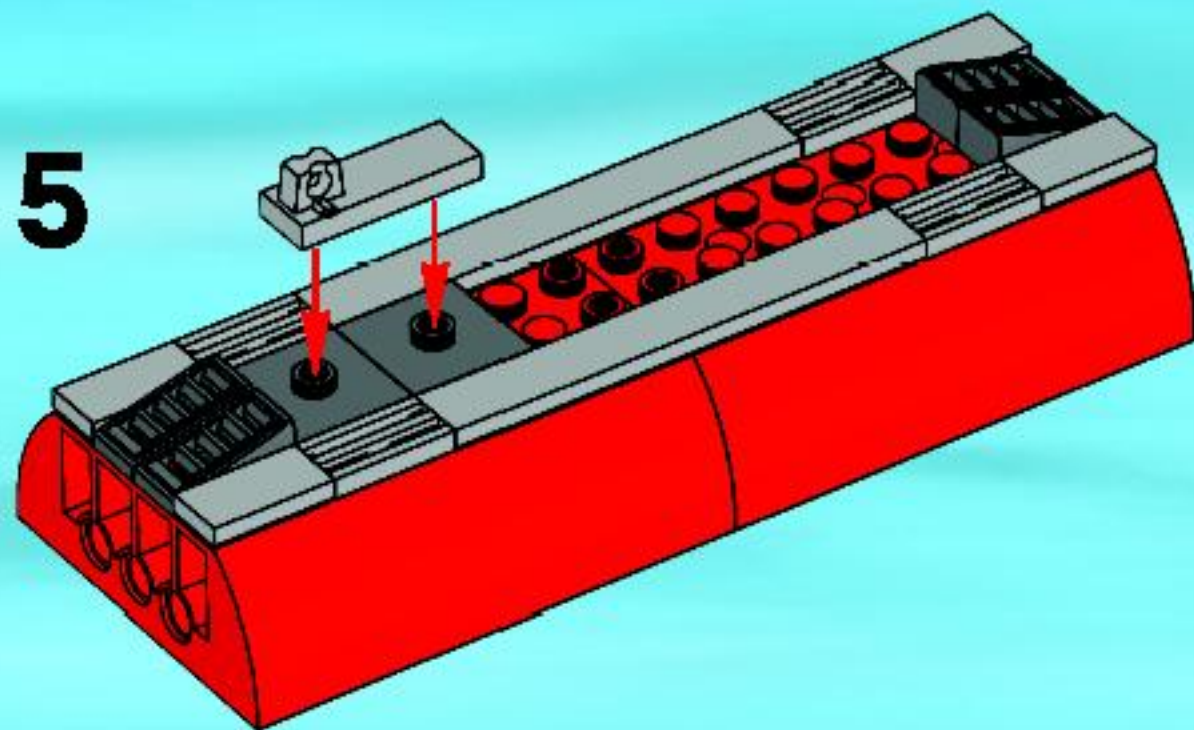

43

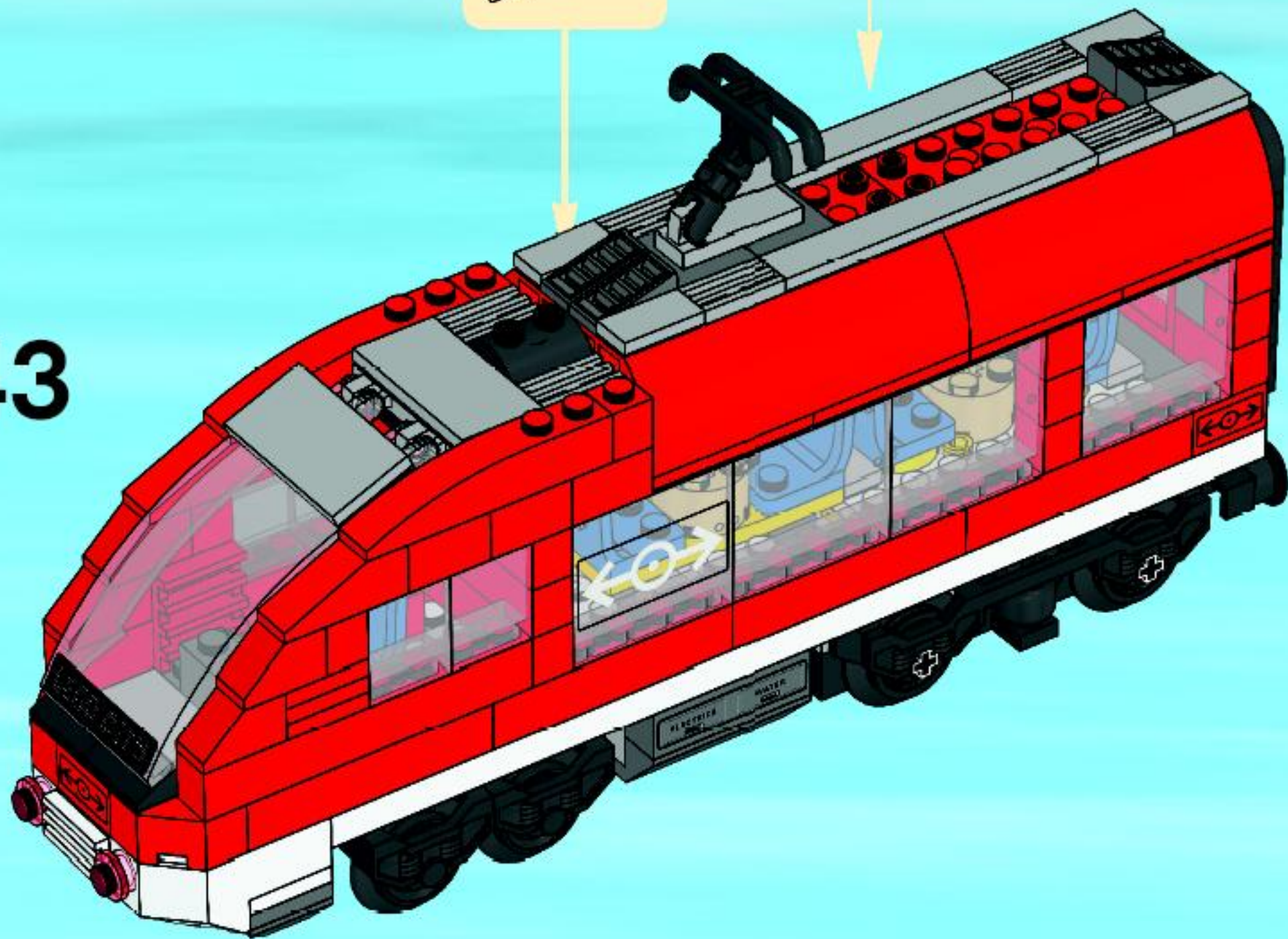



WIN!

Go to www.nielsen.com/LEGO to fill out a survey for a chance to win a cool LEGO® Product.

No purchase necessary.

Open to all residents where not prohibited.



www.nielsen.com/LEGO

GEWINNE! WIN!

Nimm an der Umfrage auf www.nielsen.com/LEGO teil und hab die Chance ein cooles LEGO® Produkt zu gewinnen!

Die Teilnahme am Gewinnspiel führt zu keinerlei Kaufverpflichtungen. Teilnahme in allen nicht ausgeschlossenen Ländern möglich.

Ga naar www.nielsen.com/LEGO, vul een enquêteformulier in en maak kans op een cool LEGO® product.

Geen aankoopverplichting. Iedereen mag deelnemen, uitgezonderd ingezetenden van landen waar een enquêteverbod geldt.

GAGNE! 当てよう!

Visite www.nielsen.com/LEGO pour répondre à un questionnaire et avoir une chance de gagner un produit LEGO® très cool!

Aucune obligation d'achat. Ouvert à tous les résidents des pays autorisés.

www.nielsen.com/LEGOにアクセスして、アンケートにご記入ください。当選者にはレゴ製品を差し上げます。

お買い上げの義務はありません。

禁止されていない限り、すべての国域にてご利用いただけます。