

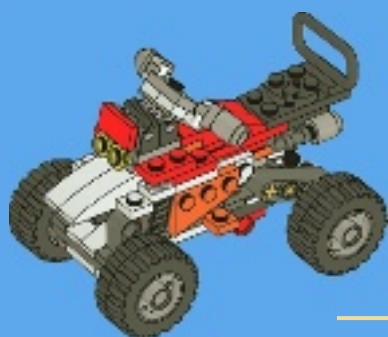

CREATOR

5763





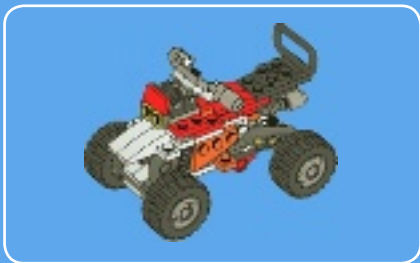

1x



1x

1

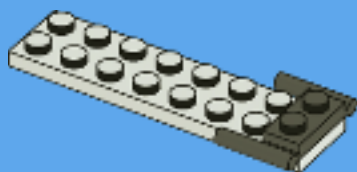

1x

2

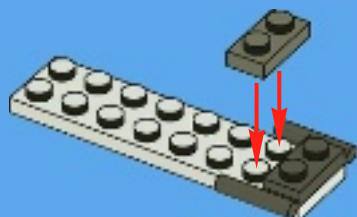



2x

3

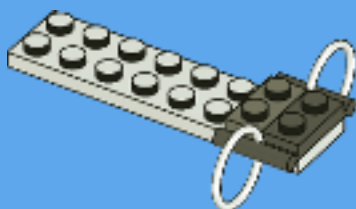

1x

4





1x



1x

5



1x



1x



1x

6

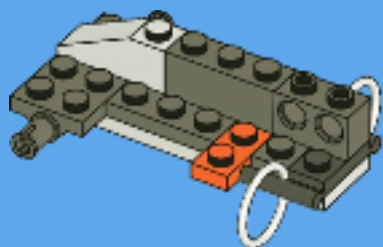



1x



1x



1x

7

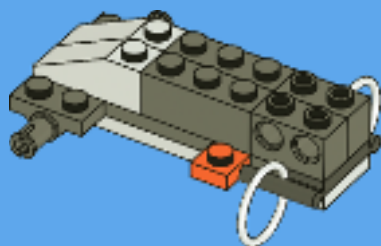



1x

8

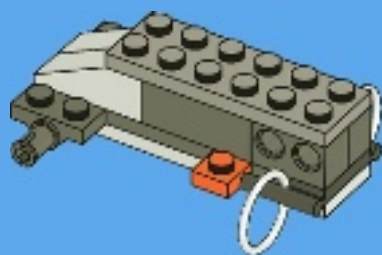

2x

9

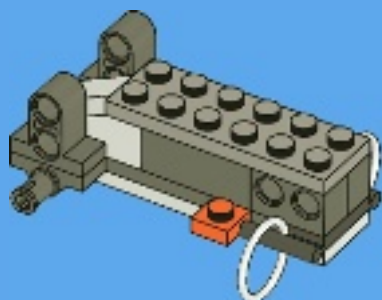



1x



2x



1x



1x

10

1

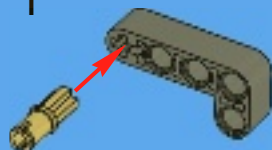

2

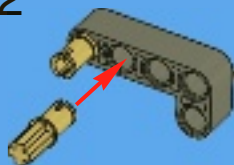

3

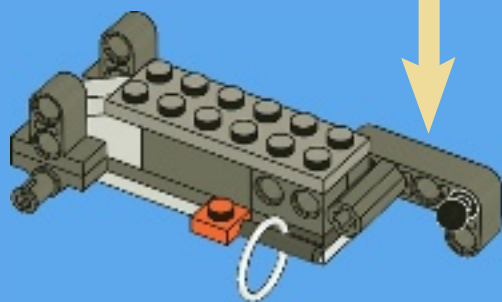



1x



2x



1x

11

1

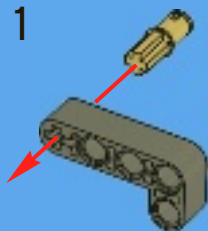

2

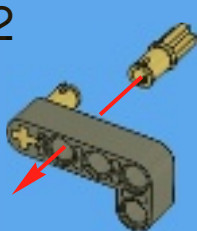

3

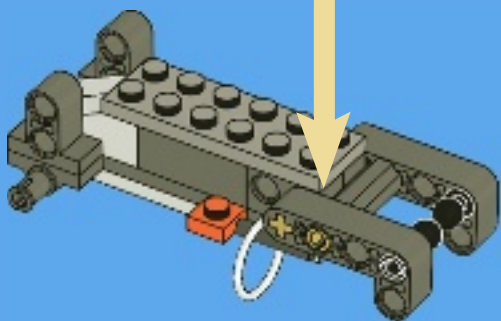
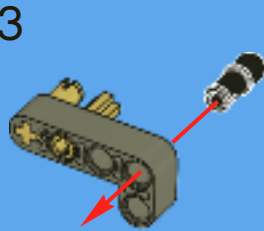



1x



1x

12

1



2

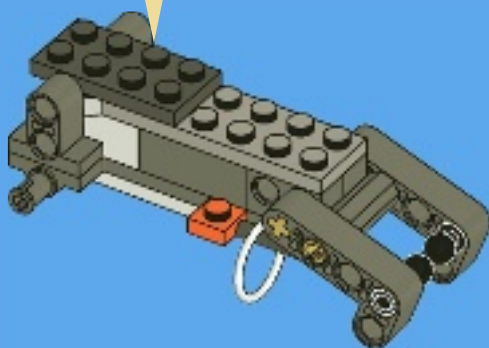



2x

13

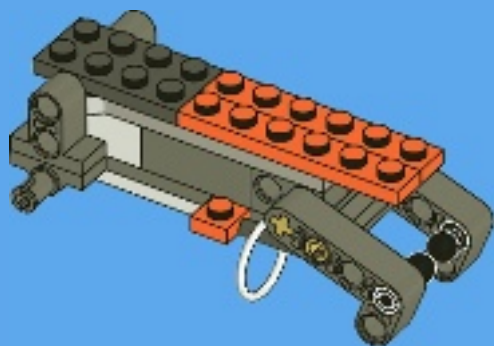

1x



2x

14

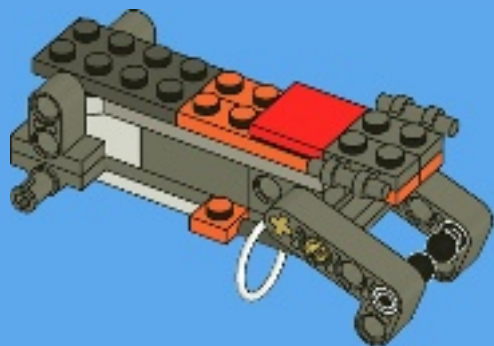



4x

15

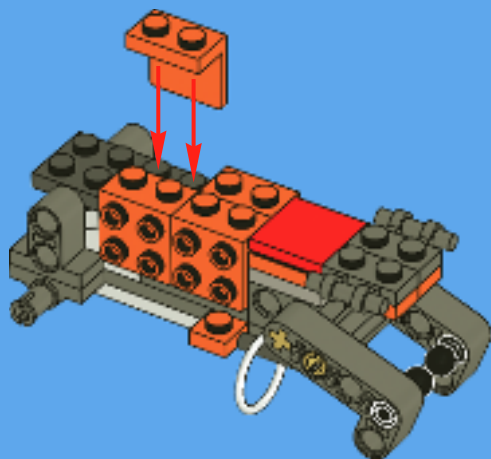



1x



1x

16

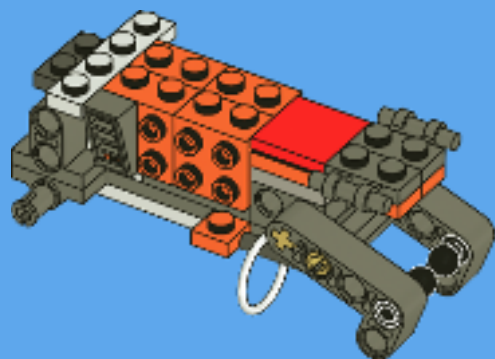



1x



1x

17

1



2

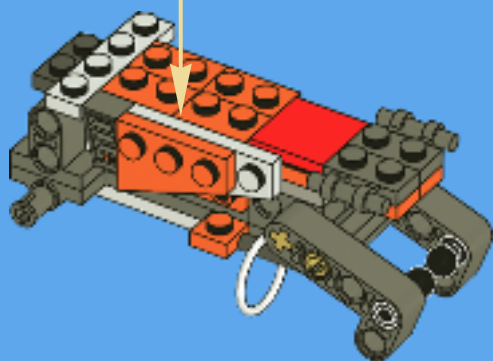



1x

18

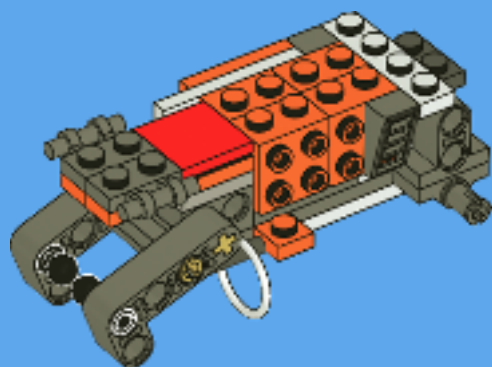



1x



1x

19

1



2

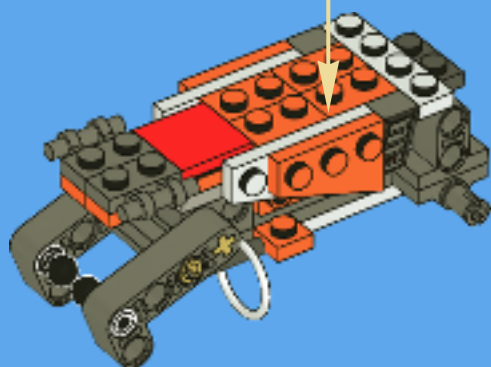



1x



1x

20

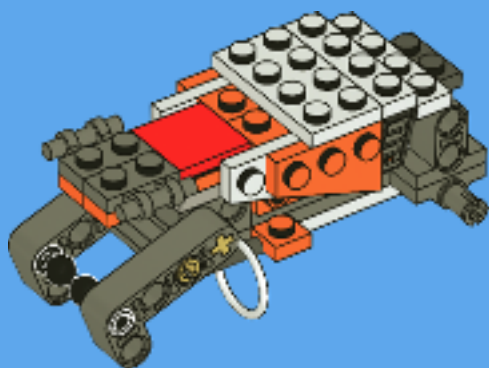

1x



1x

21

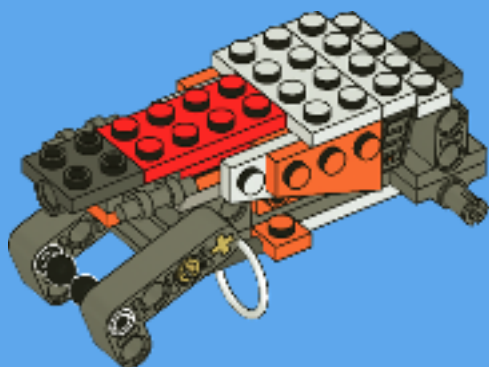



2x

22

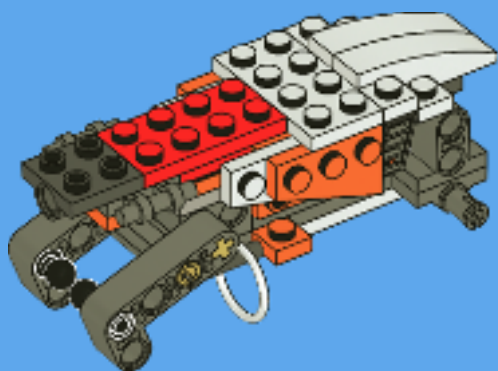



2x



1x



1x

23

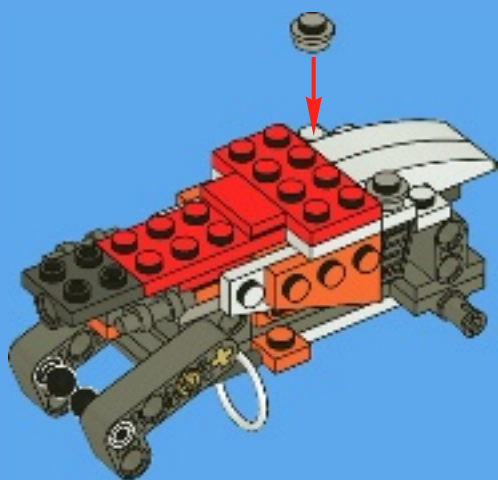



2x



1x



1x

24



2x

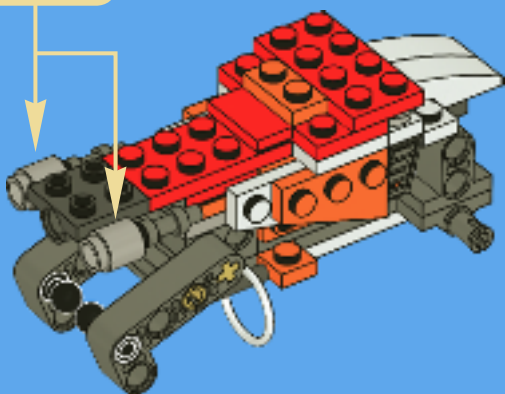



1x



2x

25

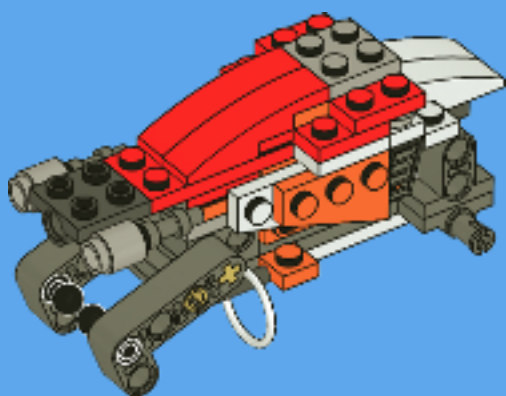



1x



1x



1x

26

1



2

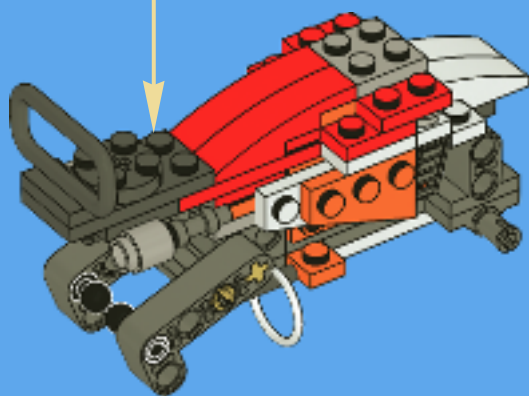



2x

27

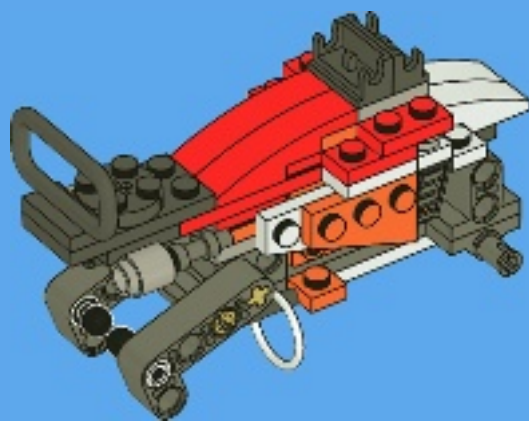

28

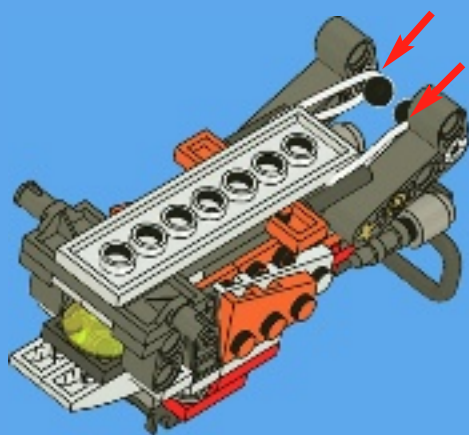



1x



2x



1x

29

1



2

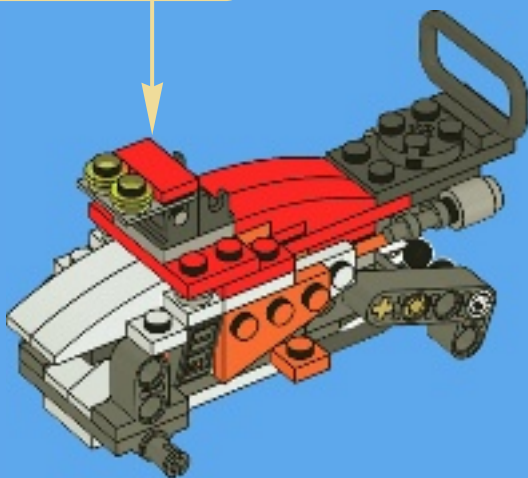



1x



1x



2x

30

1



2

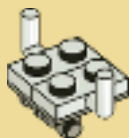

3

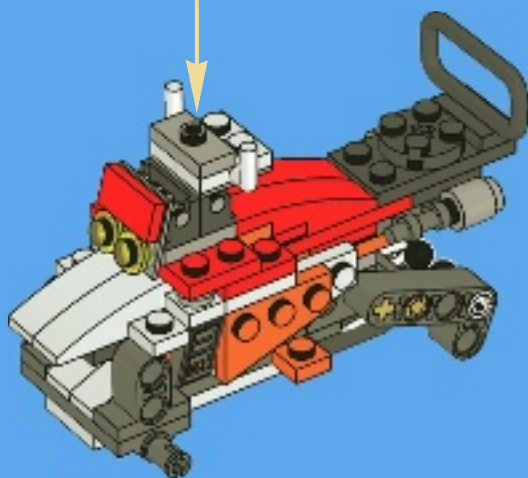



2x



1x

31

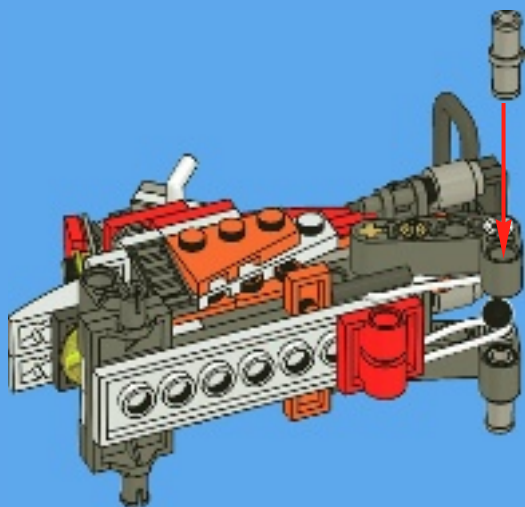



32

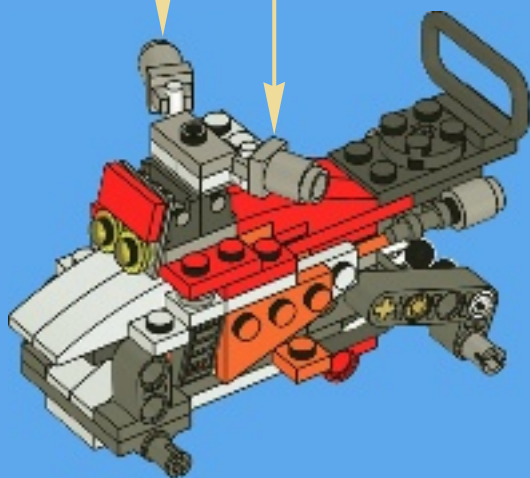
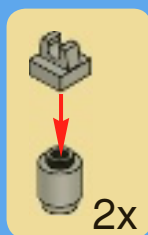



4x



4x

33

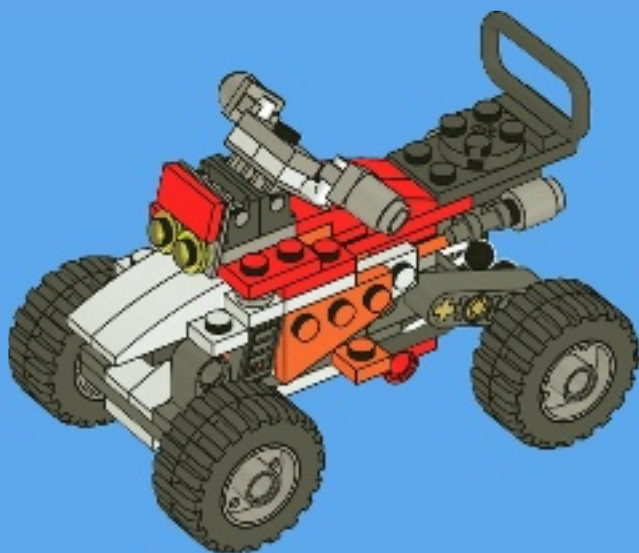

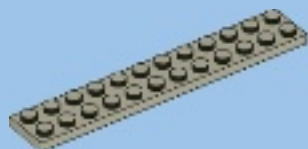

1x

1

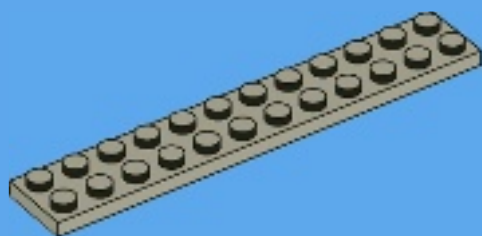

1x



1x

2

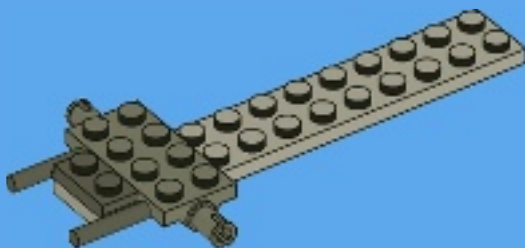



1x



1x



2x

3

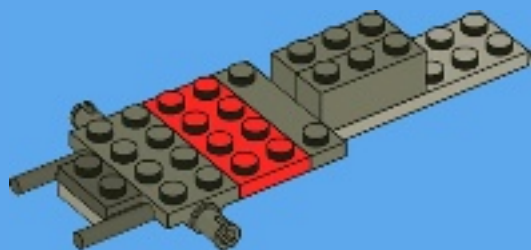

1x



1x

4

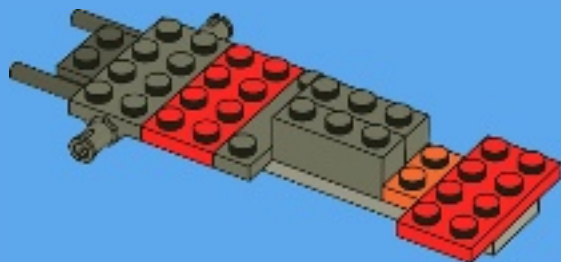



1x



1x

5

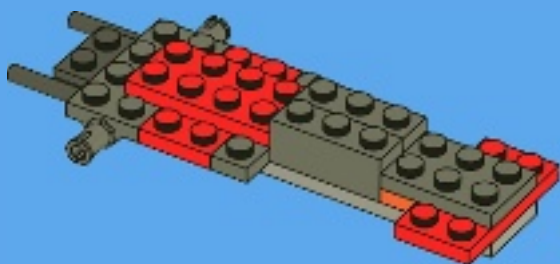

2x



2x

6

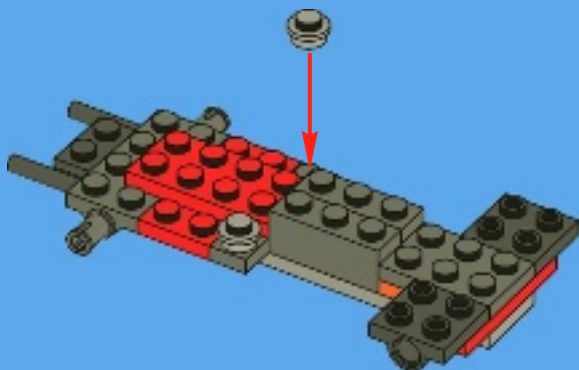



1x



2x

7

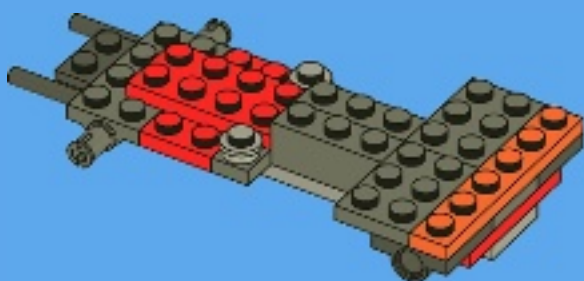

1x



1x



1x

8

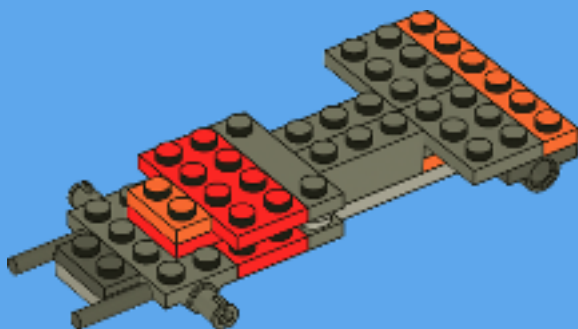



1x



2x

9

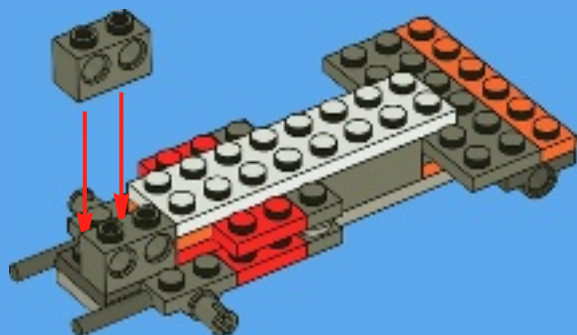

1x



2x



2x

10

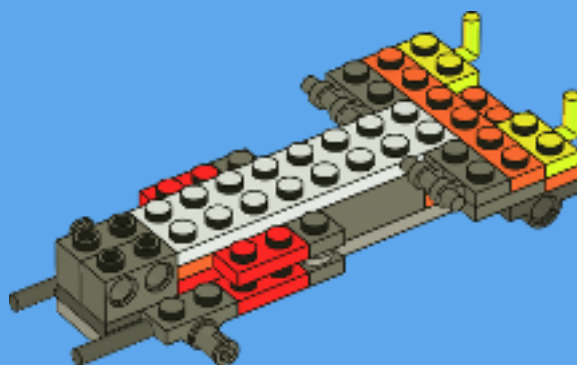



2x



2x

11

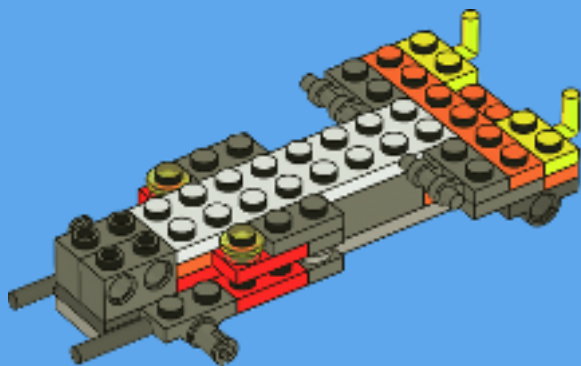

2x



2x

12

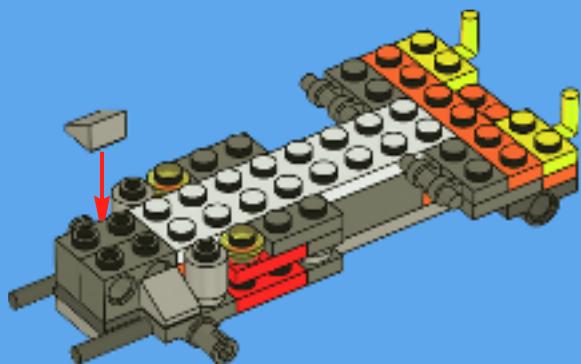



2x

13

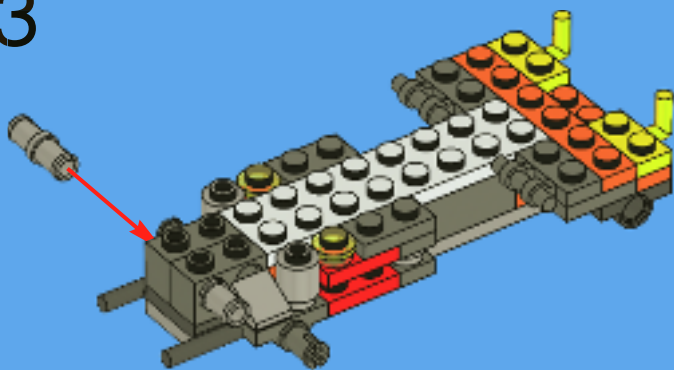

2x



1x



1x



2x

14

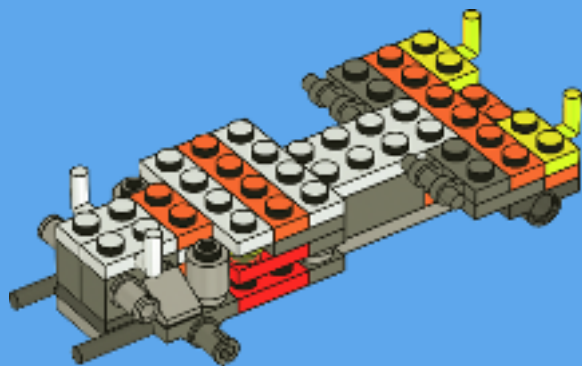



1x



1x



1x

15

1



2

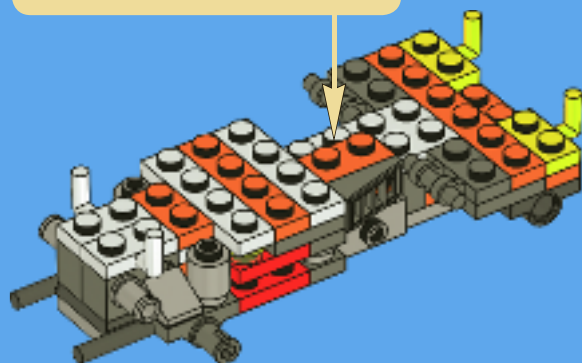



1x



1x



1x

16

1



2

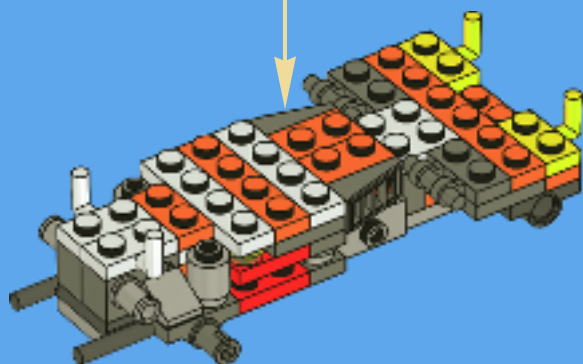



1x



2x

17

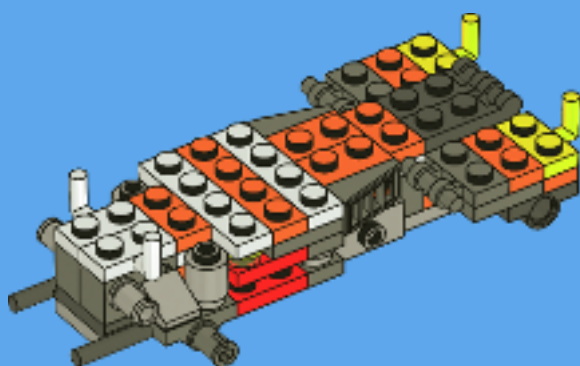



2x



2x



2x

18

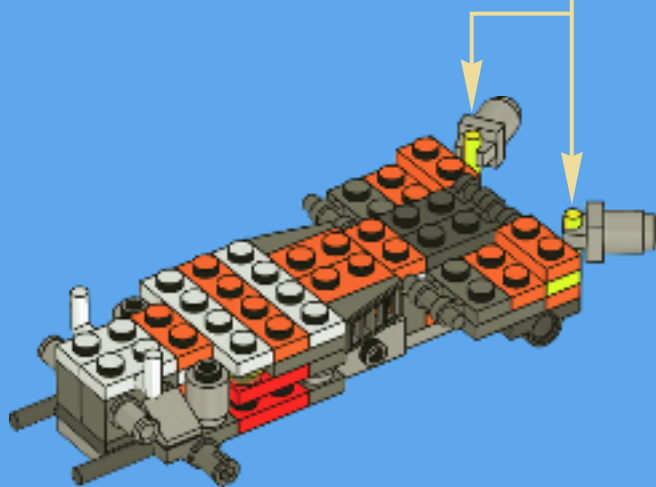
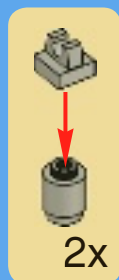



2x



1x



1x



1x

19

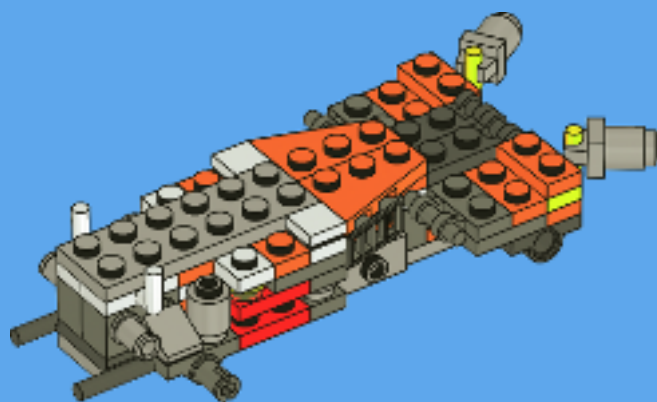



2x



2x

20

1



2



2x

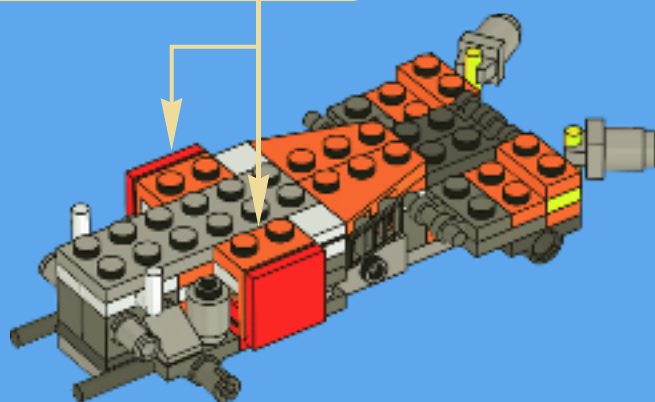



1x



2x

21

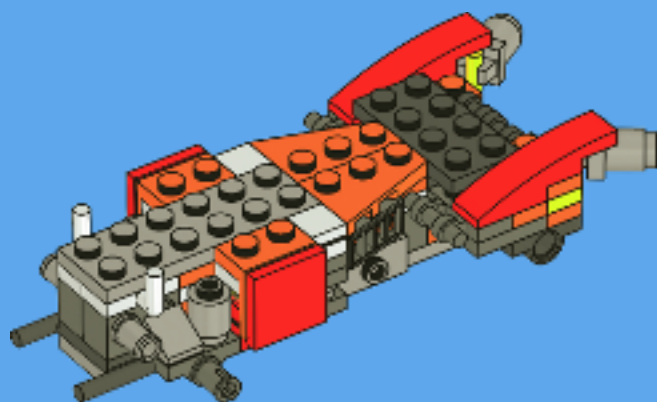



1x



2x

22

1



2

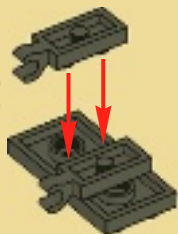



1x



1x

23

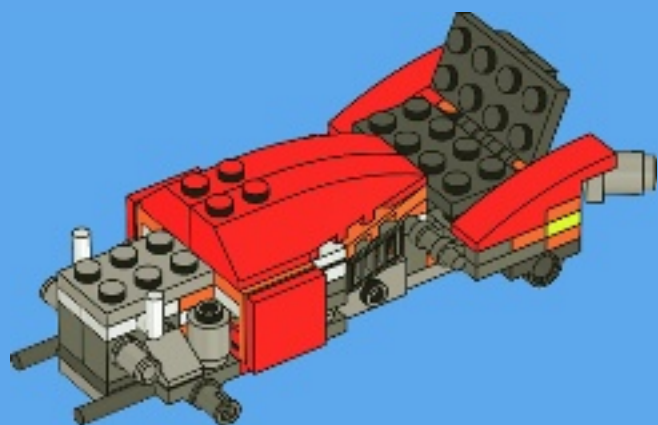



2x



2x

24

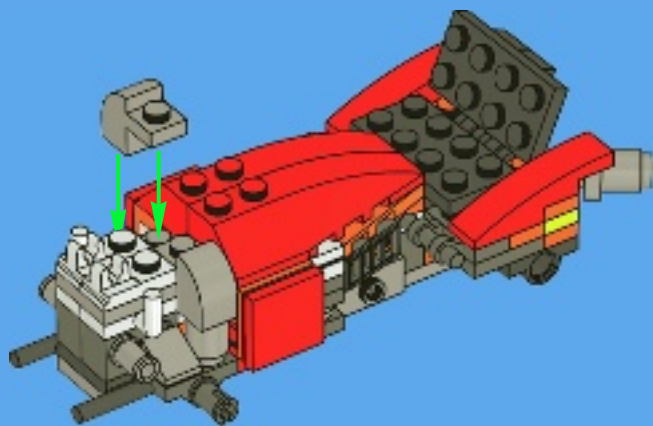



1x

25

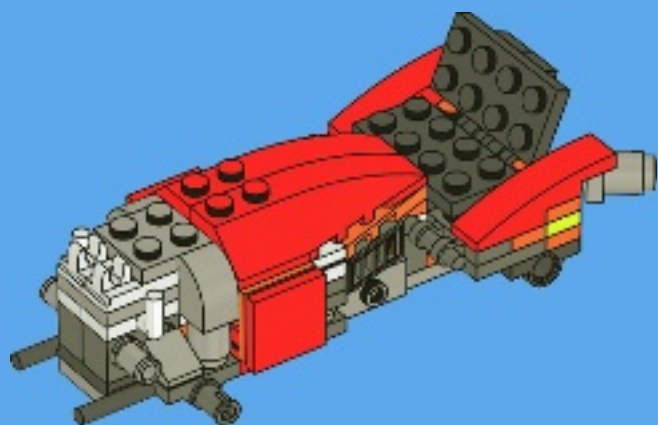



1x



1x

26

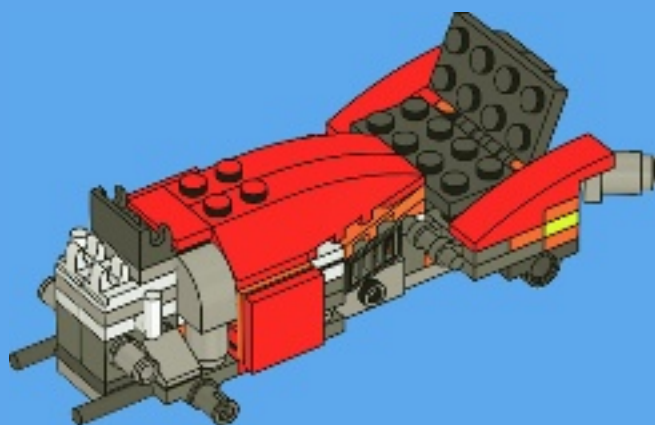



1x

27

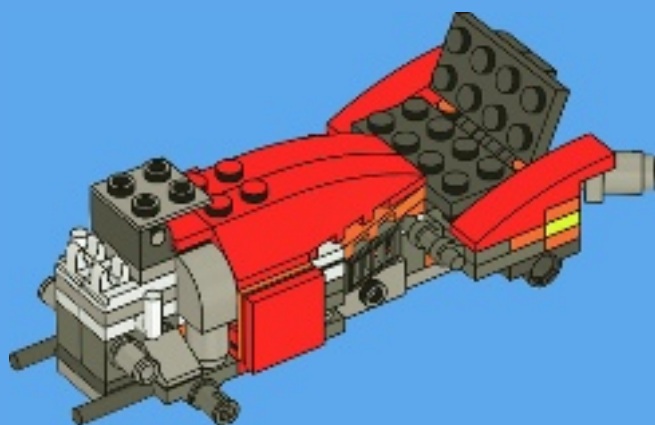



1x



2x



2x



2x

28

1



2



3

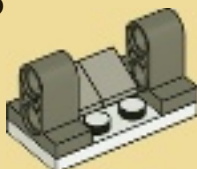

4

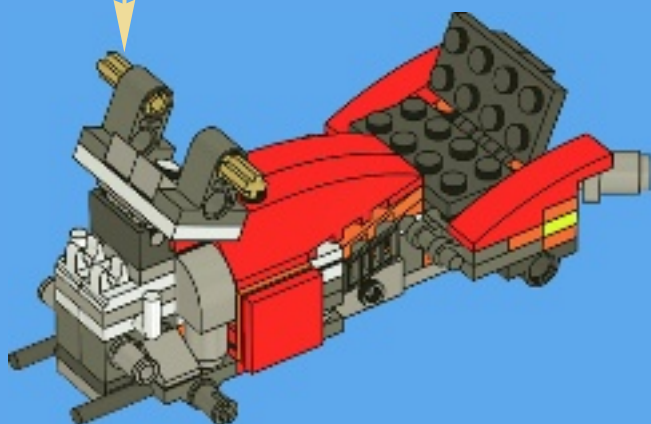
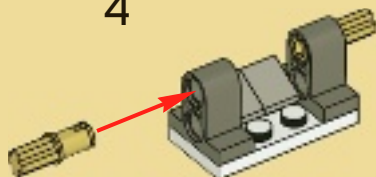



2x



1x



2x

29

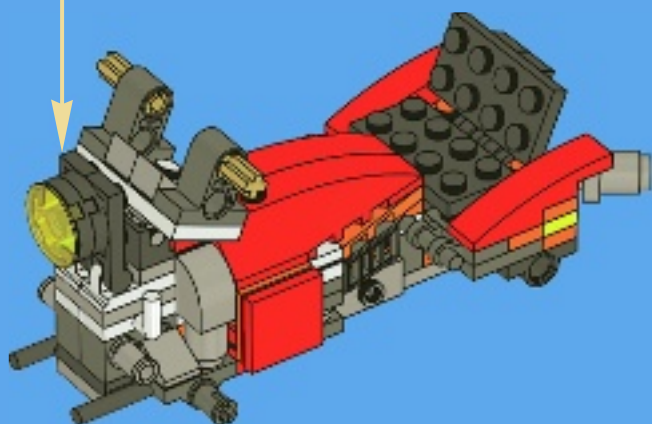
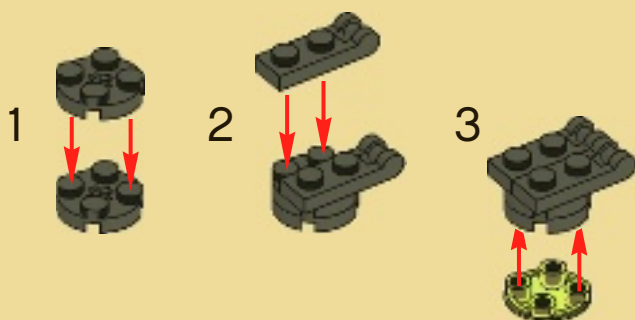



1x



1x

30

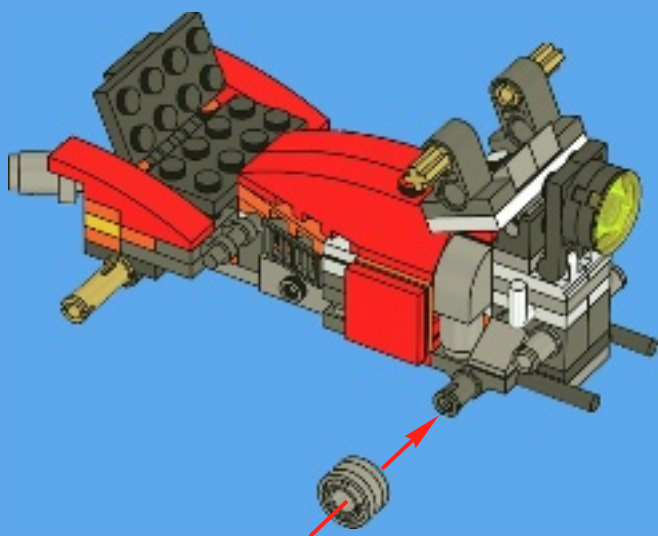



31

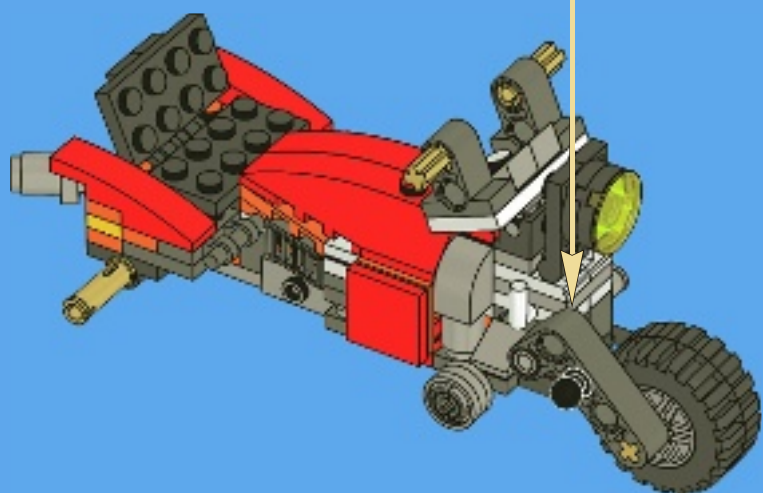
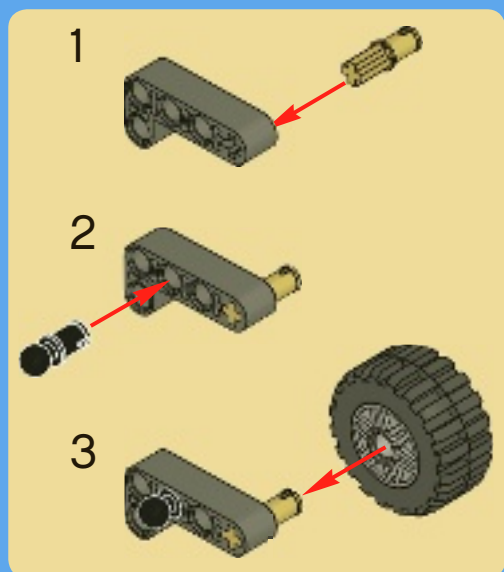



32

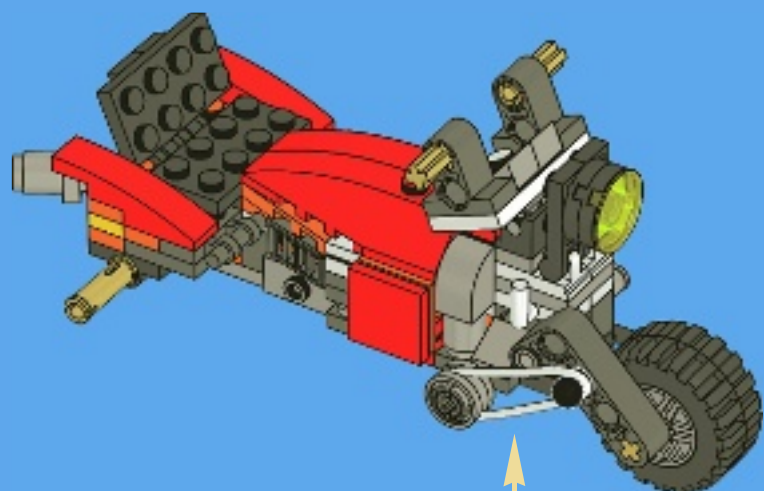



1x



1x

33

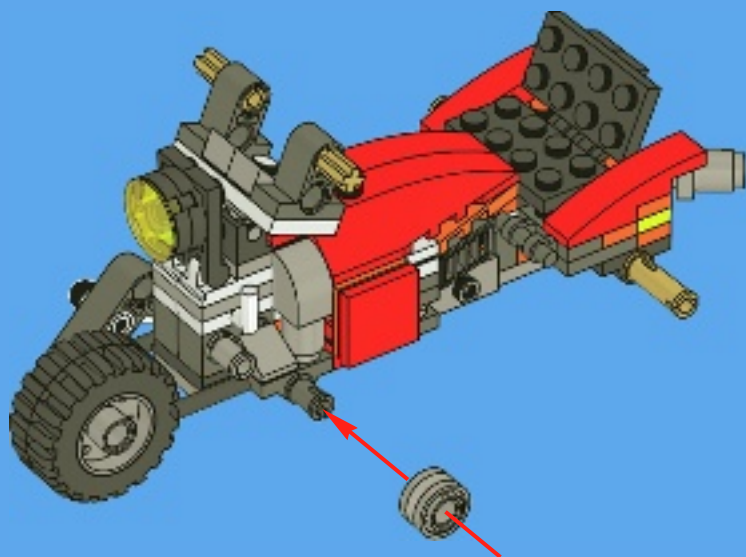



1x



1x



1x

34

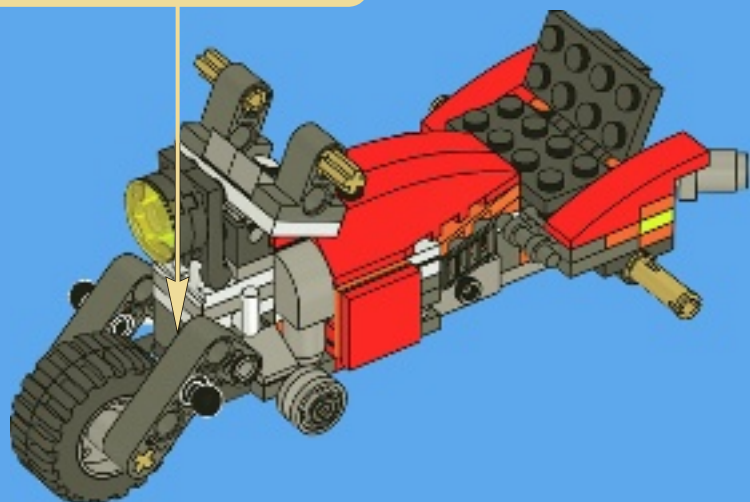
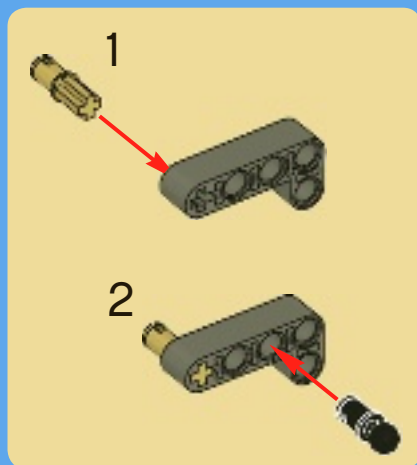



1x

35

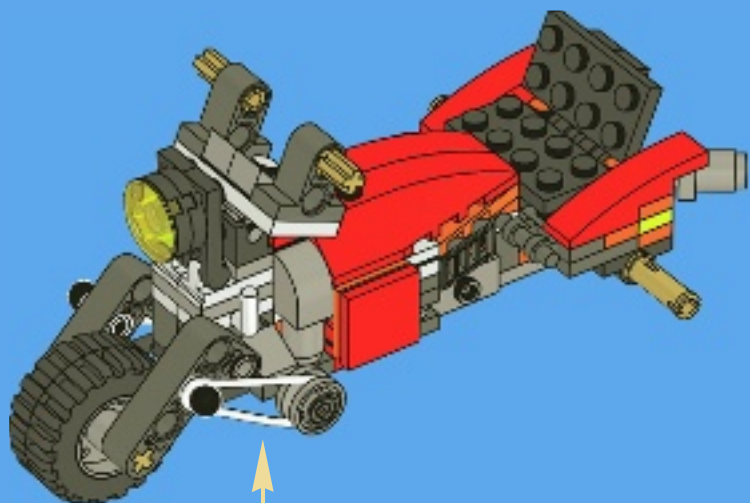



2x



2x

36

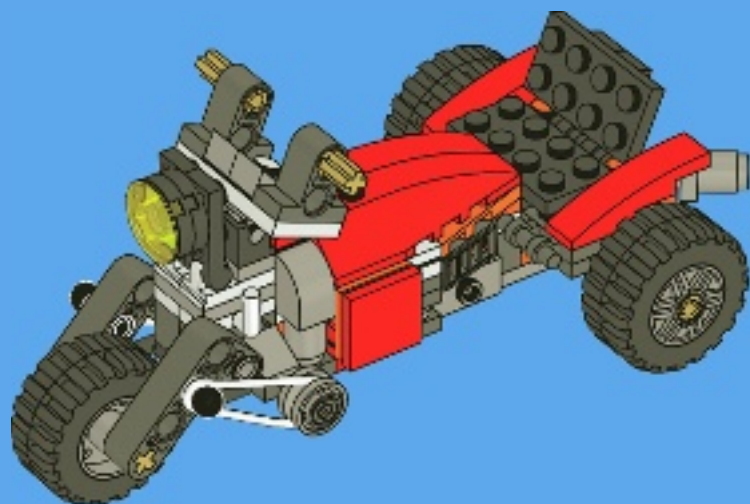



1x

37

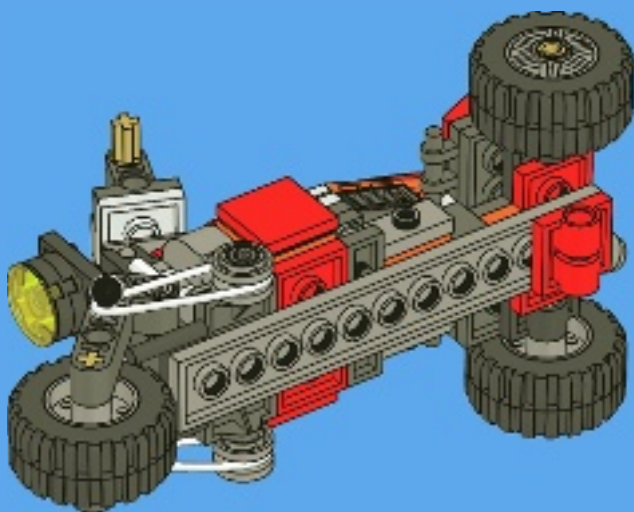

38

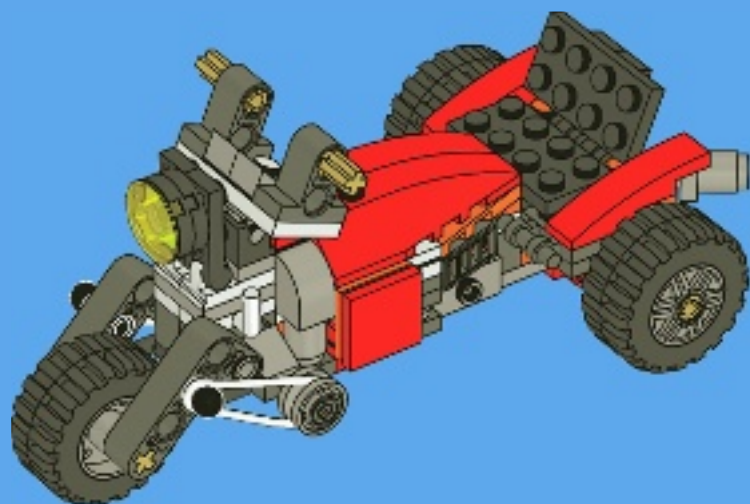



creator.LEGO.com/designers

creator.LEGO.com/movies





www.LEGOclub.com

LEGO club™

FREE! GRATIS! GRATUIT!



LEGO® Club Magazine



LEGO® Club Email

SIGN UP ONLINE!
www.LEGOclub.com

VISIT THE WORLD'S
BIGGEST LEGO® SHOP!
www.LEGOshop.com

00800 5346 5555

1-866-534-6258 • 1-877-518-5346

US & Canada only

CONTACT US ONLINE



* Freephone. Mobile charges may apply. * Numéro sans frais. Des frais peuvent s'appliquer avec les téléphones cellulaires. * Gebührenfrei. Kosten für Anrufe aus Mobilfunknetzen können abweichen.
* Gratis telefoonnummer vanaf vaste lijn. * Det er et gratis nummer, når du ringer fra fasttelefon.
* Det är gratis, när du ringer från en fast telefon. * Numéro sans frais. Des frais peuvent s'appliquer avec les téléphones portables.

BI112



CITY



7498



7288



7286



7285



7279



WIN!

Go to www.LEGOsurvey.com/product to fill out a survey for a chance to win a cool LEGO® Product.

No purchase necessary.

Open to all residents where not prohibited.

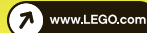

www.LEGOsurvey.com/product

GEWINNE!

Nimm an der Umfrage auf www.LEGOsurvey.com/product teil und hab die Chance ein cooles LEGO® Produkt zu gewinnen!

Die Teilnahme am Gewinnspiel führt zu keinerlei Kaufverpflichtungen. Teilnahme in allen nicht ausgeschlossenen Ländern möglich.

WIN!

Ga naar www.LEGOsurvey.com/product, vul een enquêteformulier in en maak kans op een cool LEGO® product.

Geen aankoopverplichting. Iedereen mag deelnemen, uitgezonderd ingezetenden van landen waar een enquêteverbod geldt.

GAGNE!

Visite www.LEGOsurvey.com/product pour répondre à un questionnaire et avoir une chance de gagner un produit LEGO® très cool!

Aucune obligation d'achat. Ouvert à tous les résidents des pays autorisés.

当てよう!

www.LEGOsurvey.com/product にアクセスして、アンケートにご記入ください。当選者にはレゴ製品を差し上げます。

お買い上げの必要はありません。禁止されていない限り、すべての皆様にご利用いただけます。