

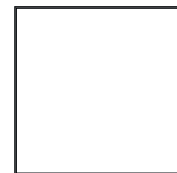

Booklet available in English on  
Livret disponible en français sur  
Folleto disponible en español en

[LEGO.com/service/buildinginstructions](https://www.LEGO.com/service/buildinginstructions)



## QUEER EYE

MORE THAN A MAKEOVER

While so many reality TV shows are about knocking people down, *Queer Eye* is all about building people up. The Fab Five use their own personal experiences – both positive and negative – to achieve a constructive and lasting impact for every single person, or heroes as the team prefers to call them, that they meet.

Join the Minifigure Fab Five in the LEGO® version of their original Atlanta loft. They're all here: fashion designer Tan France, culture expert Karamo Brown, food and wine specialist Antoni Porowski, interior designer Bobby Berk and grooming consultant Jonathan Van Ness, and they need your help to carry out their latest transformation. Enjoy!

## QUEER EYE

PLUS QU'UNE MÉTAMORPHOSE

Alors que beaucoup d'émissions de télé-réalité ne font que rabaisser les gens, *Queer Eye* vise plutôt à faire grandir les gens. Les Fab Five utilisent leurs expériences personnelles – les positives comme les négatives – pour exercer un impact constructif et durable sur les personnes, ou les héros comme l'équipe préfère les appeler, qu'ils rencontrent.

Rejoignez les figurines des Fab Five dans la version LEGO® de leur loft original d'Atlanta. Ils sont tous là : le styliste Tan France, l'expert culturel Karamo Brown, le spécialiste de la cuisine et du vin Antoni Porowski, le décorateur d'intérieur Bobby Berk et le conseiller en soins Jonathan Van Ness, et ils ont besoin de votre aide pour mener à bien leur toute dernière transformation. Amusez-vous !

## QUEER EYE

MÁS QUE UN CAMBIO DE LOOK

Mientras que muchos *reality shows* tratan de sacar a relucir los defectos de la gente, *Queer Eye* gira en torno a su resurgimiento. Los Fab Five utilizan sus propias experiencias personales —tanto positivas como negativas— para impactar constructiva y duraderamente en todas las personas, o héroes, como el equipo prefiere llamarlas, que encuentran en su camino.

Visita a las minifiguras de los Fab Five en la versión LEGO® de su *loft* original de Atlanta. Todos están aquí: el diseñador de moda Tan France, el experto en cultura Karamo Brown, el especialista en gastronomía Antoni Porowski, el diseñador de interiores Bobby Berk y el consultor de estética Jonathan Van Ness. ¡Necesitan tu ayuda para llevar a cabo su última transformación! Esperamos que disfrutes tu estancia...

# STYLE CLASS

*"Even if you're not ready to live at your full volume, turn it up halfway, and get there."*

– Bobby Berk

*« Si vous n'êtes pas prêt à vivre à votre plein volume, grimpez jusqu'à la moitié et vous y arriverez. »*

– Bobby Berk

*"Aunque no estés preparado para vivir a todo volumen, súbelo hasta la mitad y avanza poco a poco".*

– Bobby Berk



*"As a stylist, my goal is to help people be the best version of themselves."*

- Tan France

*« En tant que styliste, mon but est d'aider les gens à devenir la meilleure version d'eux-mêmes. »*

- Tan France

*"Como creador de estilo, mi objetivo es ayudar a la gente a ser la mejor versión de sí mismos".*

- Tan France

## TAN FRANCE

FASHION

Born in Doncaster, South Yorkshire, to Pakistani parents, Tan France started working in the US in 2008 and now lives in Salt Lake City, Utah. As a clothes designer and fashion expert, Tan restores people's confidence in themselves by making them feel good about what they wear. More often than not, he completes every magical makeover with his signature French Tuck!

## TAN FRANCE

MODE

Né de parents pakistanais à Doncaster, dans le Yorkshire du Sud, Tan France a commencé à travailler aux États-Unis en 2008 et vit maintenant à Salt Lake City, en Utah. En tant que créateur de vêtements et expert mode, Tan redonne confiance aux gens en s'assurant qu'ils se sentent bien dans les vêtements qu'ils portent. Le plus souvent, il complète chaque métamorphose magique avec son classique « French Tuck » !



## TAN FRANCE

MODA

Nacido en Doncaster (Yorkshire del Sur) y de padres paquistaníes, Tan France comenzó a trabajar en los EE. UU. en 2008 y hoy vive en Salt Lake City (Utah). Como diseñador y experto en moda, Tan ayuda a las personas a recuperar la confianza en sí mismas al hacerlas sentir bien sobre lo que visten. ¡Casi siempre, sus mágicos cambios de imagen acaban con su característico tuck francés!





# ANTONI POROWSKI

FOOD & WINE

As the son of Polish immigrants, Antoni grew up in Montreal, Canada, speaking Polish, English and French. After moving to the US, he studied psychology and theater before turning his talents to cooking. Before joining the Fab Five and encouraging people to start cooking for themselves, he worked for Ted Allen, the food expert from the original *Queer Eye* that ran in the early 2000s.



# ANTONI POROWSKI

CUISINE ET VIN

Fils d'immigrants polonais, Antoni a grandi à Montréal, au Canada, et parle le polonais, l'anglais et le français. Après avoir déménagé aux États-Unis, il a étudié la psychologie et le théâtre avant de se tourner vers la cuisine. Avant de rejoindre les Fab Five et d'encourager les gens à commencer à cuisiner par eux-mêmes, il a travaillé pour Ted Allen, l'expert cuisine de la série *Queer Eye* originale, diffusée au début des années 2000.

*"Food can offer a moment of pure emotional pleasure in an otherwise hard and difficult world."*  
- Antoni Porowski

*« La nourriture peut offrir un moment de pur plaisir émotionnel dans un monde autrement dur et difficile. »*  
- Antoni Porowski

*"La comida puede ofrecerte un momento de puro placer emocional en un mundo, por lo general, complicado".*  
- Antoni Porowski

# ANTONI POROWSKI

GASTRONOMÍA

Como hijo de inmigrantes polacos, Antoni creció en Montreal (Canadá) y habla polaco, inglés y francés. Después de mudarse a los EE. UU., estudió psicología y teatro, aunque finalmente dedicó su talento a la cocina. Antes de formar parte de los Fab Five y animar a la gente a iniciarse en el mundo de la cocina, trabajó para Ted Allen, el experto gastronómico que aparecía en el *Queer Eye* original, que se emitió a principios de la década de 2000.



"Life does not happen to you. Life responds to you."

- Karamo Brown

« La vie ne vous arrive pas. La vie vous répond. »

- Karamo Brown

"La vida no te sucede. La vida te responde".

- Karamo Brown

## KARAMO BROWN

CULTURE

Karamo Brown is the life coach and therapist of the group. He helps the show's heroes get to the core of understanding themselves, encouraging them to overcome the life-changing adversity they've faced. Born in Houston, Texas, of Jamaican and Cuban descent, Karamo now lives in Los Angeles with his two sons and is an active campaigner for the Black LGBT community.

## KARAMO BROWN

CULTURE

Karamo Brown est le mentor de vie et le thérapeute du groupe. Il aide les héros de l'émission à se comprendre eux-mêmes, les encourageant à surmonter l'adversité à laquelle ils ont fait face.

Né à Houston, au Texas, et d'origine jamaïcaine et cubaine,

Karamo vit maintenant à Los Angeles avec ses deux fils et est un militant actif pour la communauté LGBT noire.



## KARAMO BROWN

CULTURA

Karamo Brown es el *coach* de vida y terapeuta del grupo. Ayuda a los héroes del programa a comprenderse profundamente a sí mismos, animándolos a superar las adversidades que enfrentaron y cambiaron sus vidas. Nacido en Houston (Texas) y de ascendencia jamaicana y cubana, Karamo vive ahora en Los Ángeles con sus dos hijos y es un promotor activo de la comunidad LGBT de color.





*"When you're happy at home, it spills out into every other area of your life."*

- Bobby Berk

*« Quand vous êtes heureux à la maison, cette joie s'étend à tous les autres aspects de votre vie. »*

- Bobby Berk

*"Cuando eres feliz en casa, esa alegría salpica a todas las demás áreas de tu vida".*

- Bobby Berk



## BOBBY BERK

DESIGN

Bobby grew up in a small town in Missouri. In 2003, he moved to New York with just \$100 in his pocket. He worked his way up to become creative director for a home furnishing company before launching his own online store. On the Netflix show *Queer Eye*, Bobby revamps the living spaces of the heroes to help them transform their lives.

## BOBBY BERK

DÉCORATION

Bobby a grandi dans une petite ville du Missouri. En 2003, il s'est installé à New York avec seulement 100 \$ en poche. Il a gravi les échelons jusqu'à devenir directeur créatif pour une entreprise d'ameublement avant de lancer sa propre boutique en ligne. À l'émission *Queer Eye* sur Netflix, Bobby réaménage les espaces de vie des héros pour les aider à transformer leur vie.

## BOBBY BERK

DISEÑO

Bobby creció en un pequeño pueblo de Misuri. En 2003 se mudó a Nueva York con solo 100 dólares en el bolsillo. Se abrió camino hasta convertirse en el director creativo de una empresa de muebles para el hogar antes de lanzar su propia tienda en línea. En el programa de Netflix *Queer Eye*, Bobby renueva los espacios en los que viven los héroes para ayudarlos a transformar sus vidas.



"How you take care of yourself is how the world sees you."

- Jonathan Van Ness

« La façon dont vous prenez soin de vous est la façon dont le monde vous voit. »

- Jonathan Van Ness

"Como te cuidas a ti mismo es como te ve el mundo".

- Jonathan Van Ness

## JONATHAN VAN NESS

### GROOMING

As the enthusiastic cheerleader of the Fab Five team, Jonathan encourages the show's heroes to find some real "me-time" via their own personalized grooming and self-care moments. When not restyling hair on *Queer Eye*, Jonathan is the effusive host on a series of award-winning podcasts and a big fan of gymnastics and figure skating – it's even rumored Jonathan himself has mastered both the toe loop and axel jump on the ice!

## JONATHAN VAN NESS

### SOINS

En tant qu'enthousiaste meneur de claqué de l'équipe Fab Five, Jonathan encourage les héros de l'émission à trouver du temps rien que pour eux à travers leurs moments de soins personnels. Quand il n'est pas en train de retravailler une coupe de cheveux à *Queer Eye*, Jonathan est l'hôte exubérant d'une série de balados primés et un grand amateur de gymnastique et de patinage artistique. La rumeur veut que Jonathan lui-même aurait maîtrisé le saut de boucle piqué et le saut axel sur la glace !



## JONATHAN VAN NESS

### ESTÉTICA

Como fervoroso porrista de los Fab Five, Jonathan empuja a los héroes del programa a encontrar tiempo para dedicarse a sí mismos a través de sus propios momentos de estética y cuidado personal. Cuando no está cuidando del cabello de los protagonistas de *Queer Eye*, Jonathan es el efusivo conductor de una serie de reconocidos podcasts y un gran fan de la gimnasia y el patinaje artístico; ¡incluso se rumora que el propio Jonathan ya domina tanto el toe loop como el salto Axel en el hielo!







Bruley was the loveable French bulldog from seasons 3-4. He passed away in 2019 but is now immortalized in LEGO® form.

Bruley était l'adorable bouledogue français des saisons 3 et 4. Décédé en 2019, il est maintenant immortalisé sous forme LEGO®.

Bruley era el adorable bulldog francés de las temporadas 3 y 4. Nos dejó en 2019, y ahora vivirá para siempre en formato LEGO®.



## EVERY GUEST IS A HERO

Every hero on *Queer Eye* has a special story to tell. Some have faced the traumas of losing a loved one, overcome a serious medical condition, or faced rejection by their family. Others have given so much to others and their local communities that they've had little time to look after themselves. They are all heroes to the Fab Five – and all deserving of a transformation that will make their lives easier, healthier and happier.

## CHAQUE INVITÉ EST UN HÉROS

Chaque héros de *Queer Eye* a une histoire unique à raconter. Certains ont perdu un être cher, surmonté une grave maladie ou subi le rejet de leur famille. D'autres ont tellement donné aux autres et à leurs communautés qu'ils ont eu peu de temps à se consacrer à eux-mêmes. Ils sont tous des héros pour les Fab Five – et tous méritent une transformation qui leur rendra la vie plus facile, plus saine et plus heureuse.

## TODOS LOS INVITADOS SON HÉROES

Cada uno de los héroes de *Queer Eye* tiene una historia especial que contar. Algunos han vivido la traumática experiencia de perder a un ser querido, superado una condición médica grave o enfrentado el rechazo de su familia. Otros han dado tanto a los demás y a sus comunidades que han tenido poco tiempo para cuidar de sí mismos. Todos ellos son héroes para los Fab Five y, por eso, merecen una transformación que haga sus vidas más sencillas, saludables y felices.

### THIS WEEK'S GUEST

It wouldn't be a proper *Queer Eye* LEGO® set unless someone was getting a magical makeover! Meet Kathi Dooley, a dedicated teacher who played a special role in Jonathan's early life, supporting him with understanding and kindness. Now it's time for Jonathan and friends to repay the favor...

### L'INVITÉE DE LA SEMAINE

Ce ne serait pas un ensemble LEGO® *Queer Eye* complet sans une métamorphose magique ! Voici Kathi Dooley, une enseignante dévouée qui a joué un rôle important dans les débuts de Jonathan en lui apportant un soutien débordant de compréhension et de gentillesse. Maintenant, il est temps pour Jonathan et ses amis de lui rendre la pareille...

### EL INVITADO DE ESTA SEMANA

¡Un set LEGO® *Queer Eye* no podría estar completo sin que alguien pasara por una mágica transformación! Te presentamos a Kathi Dooley, una dedicada maestra cuya comprensión y amabilidad resultaron fundamentales para Jonathan durante los primeros años de su vida. Es hora de que Jonathan y sus amigos devuelvan el favor...



Kathi Dooley's LEGO makeover  
La métamorphose LEGO de Kathi Dooley  
Transformación LEGO de Kathi Dooley



Before  
Avant  
Antes

After  
Après  
Después

## MORE THAN A MAKEOVER

### A TRUE COLLABORATION!

This *Queer Eye* LEGO® set was the result of a true Fab Five-style collaboration between the LEGO design team and the show's own design guru, Bobby Berk. For Bobby it quickly became a passion project: "LEGO played such an important part in my childhood. Clicking those little bricks together really sparked my imagination and creativity." Matthew Ashton, LEGO Vice President of Design, saw the collaboration as the perfect partnership: "We share so many values, like caring, learning, creativity and fun. While the Fab Five rebuild people's lives, we are on a mission to inspire kids and adults to get creative and be part of rebuilding a more positive world."

The first task was to decide exactly what the set should be. The team quickly zeroed in on the original loft setting from the first season and together defined the model's floor plan and layout. For Matthew it was vital they captured as many details as possible: "We wanted to replicate the furniture and include iconic details like the *STYLE, TASTE, CLASS*' sign. We also wanted to include a distinct zone for each of the guys and play up to each of the Fab Five's unique skills and contributions to the team."

## PLUS QU'UNE MÉTAMORPHOSE

### UNE VRAIE COLLABORATION !

Cet ensemble LEGO® *Queer Eye* est le résultat d'une vraie collaboration digne des Fab Five entre l'équipe de conception LEGO et le gourou de la décoration de l'émission, Bobby Berk. Pour Bobby, l'ensemble est rapidement devenu un projet personnel : « LEGO a joué un rôle si important dans mon enfance. Assembler ces petites briques a vraiment éveillé mon imagination et ma créativité. » Matthew Ashton, vice-président de la conception LEGO, a vu dans cette collaboration le partenariat parfait : « Nous partageons tant de valeurs, comme la bienveillance, l'apprentissage, la créativité et le plaisir. Alors que les Fab Five reconstruisent la vie des gens, nous avons pour mission d'inspirer les enfants et les adultes à être créatifs et à prendre part à la reconstruction d'un monde plus positif. »

La première tâche consistait à décider ce que l'ensemble allait représenter. L'équipe a rapidement choisi de reproduire le décor du loft de la première saison et travaillé à l'élaboration du plan et de la disposition du modèle. Pour Matthew, il était vital de saisir autant de détails que possible : « Nous voulions reproduire les meubles et inclure des détails emblématiques tels que l'inscription "STYLE, TASTE, CLASS". Nous voulions aussi inclure une zone distincte pour chacun des gars du Fab Five et mettre en valeur leurs compétences uniques respectives et leurs contributions à l'équipe. »



Bobby's cool design skills started at an early age ... with a LEGO® set!  
Bobby a commencé à développer ses compétences de conception à un jeune âge... avec un ensemble LEGO® !  
La increíble habilidad para el diseño de Bobby se hizo evidente desde muy temprana edad... ¡con un set LEGO®!

## MÁS QUE UN CAMBIO DE LOOK

### ¡UNA VERDADERA COLABORACIÓN!

Este set LEGO® *Queer Eye* es el resultado de una verdadera colaboración al estilo de los Fab Five entre el equipo de diseño de LEGO y el gurú de diseño del programa, Bobby Berk. Para Bobby, el proyecto no tardó en convertirse en una pasión: "LEGO interpretó un papel sumamente importante durante mi niñez. Conectar los pequeños bricks ponía a funcionar mi imaginación y creatividad como ninguna otra cosa". Desde la perspectiva de Matthew Ashton, vicepresidente de Diseño en LEGO, esta colaboración fue una alianza perfecta: "Compartimos muchísimos valores, como la amabilidad, el aprendizaje, la creatividad y la diversión. Mientras que los Fab Five se dedican a reconstruir las vidas de las personas, nuestra misión es inspirar a niños y adultos a ser creativos y formar parte de la reconstrucción de un mundo más positivo".

La primera tarea consistió en decidir exactamente qué representar en el set. Sin necesidad de un gran debate, el equipo deliberó que se crearía un modelo del escenario original del loft de la primera temporada, y juntos definieron su disposición. Para Matthew, capturar tantos detalles como fuera posible era fundamental: "Queríamos replicar los muebles e incluir detalles icónicos como el letrero con la leyenda 'STYLE, TASTE, CLASS'. También queríamos incluir un área distinta para cada uno de los chicos y representar las inigualables habilidades y aportaciones al equipo de cada uno de ellos".



*"Collaborating with the LEGO team was an absolute dream come true! It would be any kid's dream and now my reality."*

*- Bobby Berk*

*« Collaborer avec l'équipe LEGO était un rêve devenu réalité ! C'est le rêve de tout enfant, et c'est maintenant ma réalité. »*

*- Bobby Berk*

*"¡Colaborar con el equipo de LEGO fue un sueño hecho realidad en todos los aspectos!*

*Lo que sería el sueño de cualquier niño es ahora mi realidad".*

*- Bobby Berk*



Bobby and Matthew in the initial stages of the design process.  
Bobby et Matthew lors des premières étapes du processus de conception.  
Bobby y Matthew en las etapas iniciales del proceso de diseño.



## CLICKING IT ALL TOGETHER

Just like it is for the Fab Five, teamwork is an essential part of developing a great LEGO® set. The other members of Matthew's LEGO Dream team were Senior Graphic Designer, Diego Sancho and Senior Element Designer, Ruth Kelly.

Diego had the important task of capturing the Fab 5's likeness in LEGO minifigure form, as well as designing all the decorations and stickers to bring the loft to life: *"I got the opportunity to do my personal take on the artwork for the loft, to add some nice Easter Eggs for the fans! I created a 'Yaaas Queen' print for the kitchen to celebrate the fun LGBTQ+ saying, and if you look closely at the unique brush-stroke art you will see it says FAB 5!"*

For Ruth the challenge was very different: *"We simply didn't have any existing wigs with a coif quite as voluminous as Tan's, so it was my job to sculpt a new one. We decided to mold the wig in shimmering silver plastic to really 'elevate' Tan's look!"*

Matthew is proud of the finished set and what the partnership stands for: *"The Fab Five have had such a positive impact on so many peoples' lives. We need to take time to celebrate kindness and this collaboration has been the perfect way to showcase that."*

## TOUT S'IMBRIQUE PARFAITEMENT

Tout comme pour les Fab Five, le travail d'équipe est un élément essentiel de l'élaboration d'un formidable ensemble LEGO®. Les autres membres de la merveilleuse équipe LEGO de Matthew étaient le graphiste principal, Diego Sancho, et la conceptrice d'éléments principale, Ruth Kelly.

Diego a eu la tâche importante de recréer l'apparence des Fab 5 sous forme de figurines LEGO, ainsi que de concevoir les décorations et les autocollants qui donnent vie au loft : *« J'ai eu l'occasion d'apporter ma touche personnelle aux illustrations dans le loft, et ainsi d'ajouter quelques beaux œufs de Pâques pour les amateurs ! J'ai créé une affiche "Yaaas Queen" pour la cuisine afin de célébrer l'amusante phrase LGBTQ+, et si vous regardez attentivement l'œuvre en coups de pinceau, vous verrez qu'elle dit FAB 5 ! »*

Ruth a dû relever un défi très différent : *« Nous n'avions tout simplement pas de perruques avec une coiffure aussi volumineuse que celle de Tan, alors j'ai dû sculpter une nouvelle. Nous avons décidé de mouler la perruque en plastique argenté chatoyant pour vraiment "élever" le look de Tan ! »*

Matthew est fier de l'ensemble fini et de ce que le partenariat représente : *« Les Fab Five ont eu un impact tellement positif sur la vie de tellement de gens. Nous devons prendre le temps de célébrer la gentillesse, et cette collaboration a été le moyen idéal de mettre cette nécessité en valeur. »*

## CONECTAR TODAS LAS PIEZAS

Al igual que para los Fab Five, el trabajo en equipo es un ingrediente esencial para el desarrollo de un set LEGO® que se vuelva inolvidable. Los otros miembros del equipo de élite de Matthew en LEGO fueron Diego Sancho, diseñador gráfico sénior, y Ruth Kelly, diseñadora de elementos sénior.

Diego se encargó de la importante tarea de capturar la esencia de los Fab Five en forma de minifiguras LEGO, así como de diseñar adornos y calcomanías que dieran vida al loft: *"Tuve la oportunidad de dar mi toque personal a la decoración del loft, ¡y de añadir algunos increíbles huevos de Pascua para los fans! Puse la leyenda 'Yaaas Queen' en la cocina para celebrar el divertido grito de guerra de la comunidad LGBTQ+. Además, si miras de cerca las pinceladas del cuadro, ¡notarás que dice 'FAB 5'!"*

Ruth enfrentó un desafío muy diferente: *"Dicho simplemente, ninguna de nuestras pelucas tenía la altura y el volumen del cabello de Tan, por lo que mi trabajo consistió en esculpir una nueva. Decidimos moldear la peluca en reluciente plástico color plata para 'elevar' el look de Tan".*

Matthew está orgulloso de la versión final del set y de lo que significa la alianza: *"Los Fab Five fueron una influencia positiva en la vida de muchísimas personas. Necesitamos dedicar tiempo para celebrar la amabilidad, y esta colaboración representa una oportunidad invaluable para poner de manifiesto este valor".*



Left to right:  
Ruth Kelly, Senior Element Designer  
Matthew Ashton, Vice President of Design  
Diego Sancho, Senior Graphic Designer

De gauche à droite :  
Ruth Kelly, conceptrice d'éléments principale  
Matthew Ashton, vice-président de la conception  
Diego Sancho, graphiste principal

De izquierda a derecha:  
Ruth Kelly, diseñadora de elementos sénior  
Matthew Ashton, vicepresidente de Diseño  
Diego Sancho, diseñador gráfico sénior

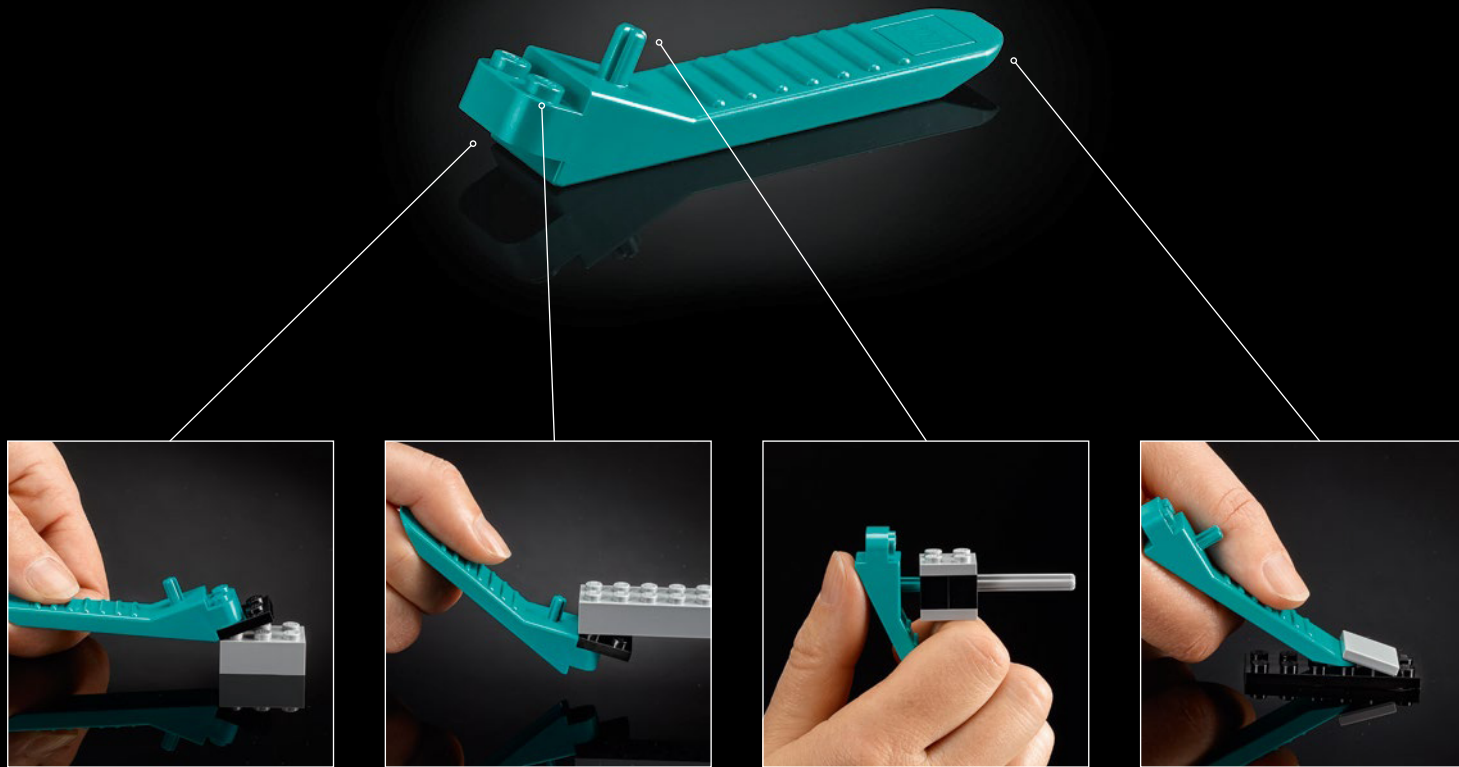

[LEGO.com/brickseparator](https://www.lego.com/brickseparator)

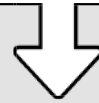
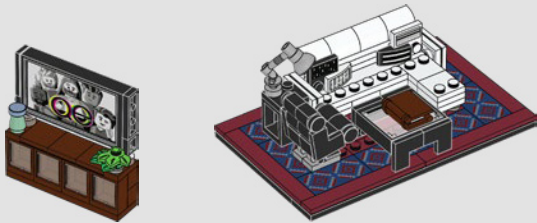
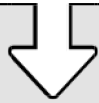

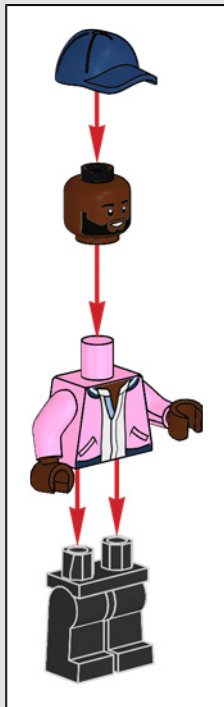
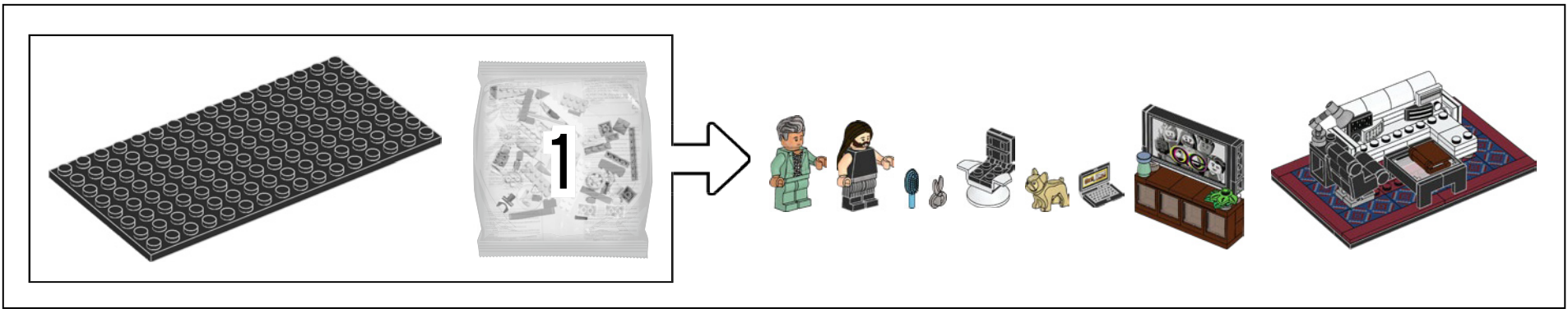

Karamo Brown

"Glad to see they made me rocking a signature Karamo bomber jacket, and good choice on the baseball cap to cover that unsightly bump on my head! Ha!"

« Je suis heureux de voir qu'ils m'ont enfilé mon fameux blouson d'aviateur, et c'est un choix judicieux d'avoir inclus la casquette pour couvrir cette bosse disgracieuse sur ma tête ! Ha ! »

"Me encantó ver que me reprodujeran usando la chamarra de vuelo que me caracteriza y una gorra perfectamente combinada: ¡así queda oculto ese enorme bulto en mi cabeza! Es simplemente maravilloso".

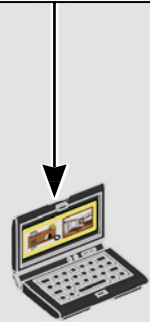
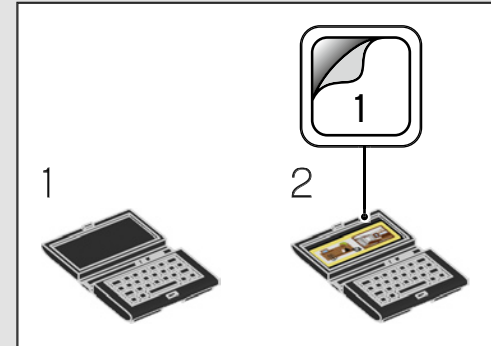



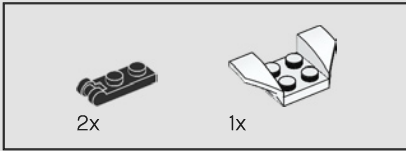
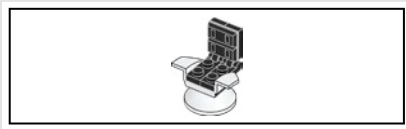

1

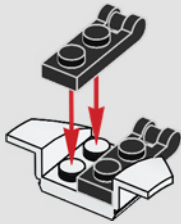

2

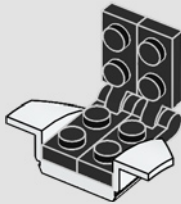

3

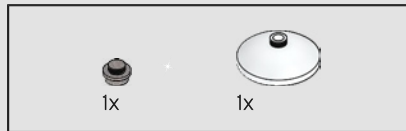
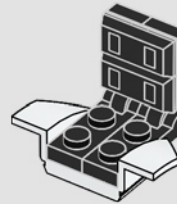

4

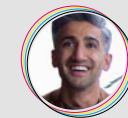
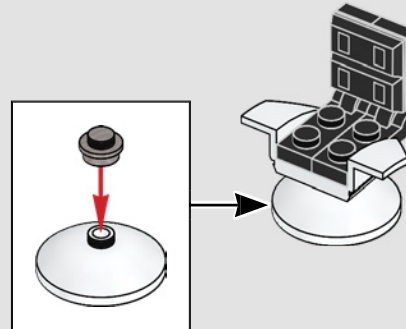

Tan France

"Ha! That little LEGO® wig is pure perfection! And much like my real hair once it is sprayed into place, it doesn't move an inch."

« Ha ! Cette petite perruque LEGO® est la perfection même ! Et tout comme ma vraie chevelure une fois qu'elle a été vaporisée, elle ne bouge pas d'un cheveu. »

"¡Mira! ¡Esa peluquita LEGO® es la definición de la perfección! Y, al igual que mi cabello bajo el efecto del fijador, no se mueve ni un centímetro".



Jonathan Van Ness

"Could LEGO us be any cuter?!"

« Nos figurines LEGO sont trop mignonnes ! »

"¡LEGO no podría ser más lindo!".

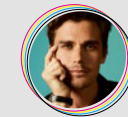

Antoni Porowski

"It's so cute that they included Bruley! I miss that little Pupperoni!"

« C'est tellement mignon qu'ils aient inclus Bruley ! Ce petit toutou me manque ! »

"Es tan lindo que hayan incluido a Bruley. ¡Cómo extraño a ese adorable cachorrito!".

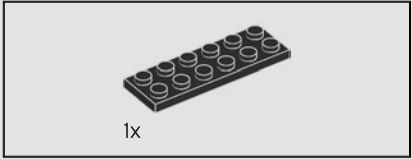
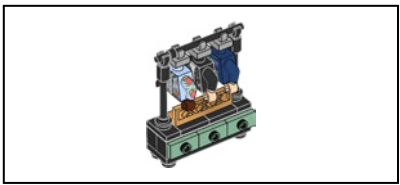

1

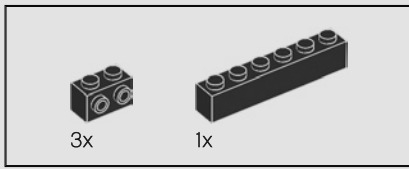
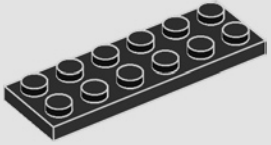

2

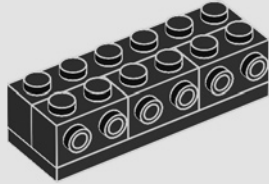

3

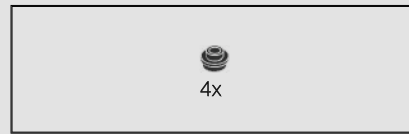
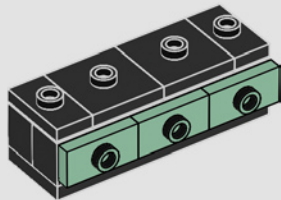

4

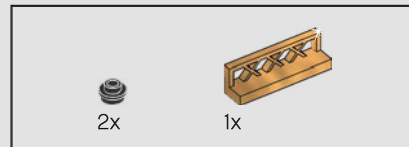
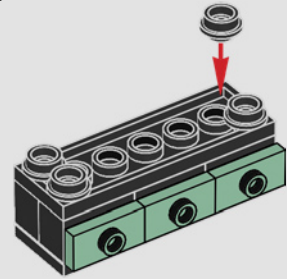
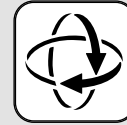

5

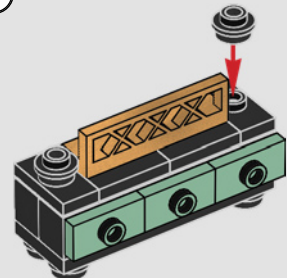
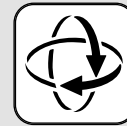



6

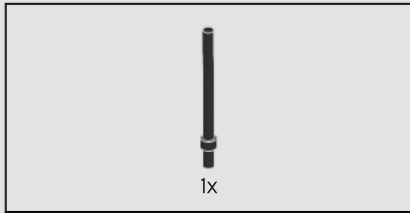
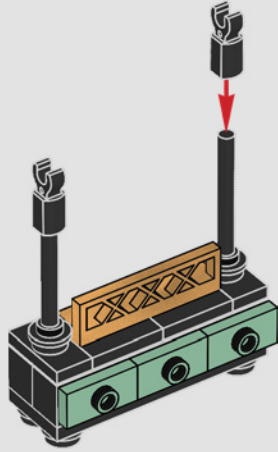

7

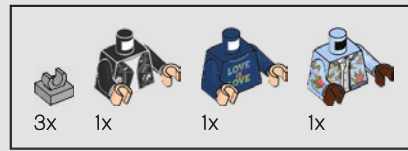
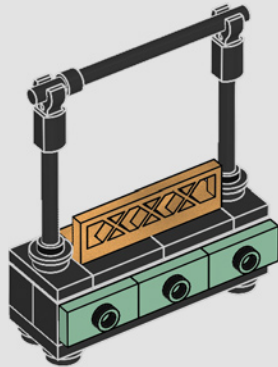

8

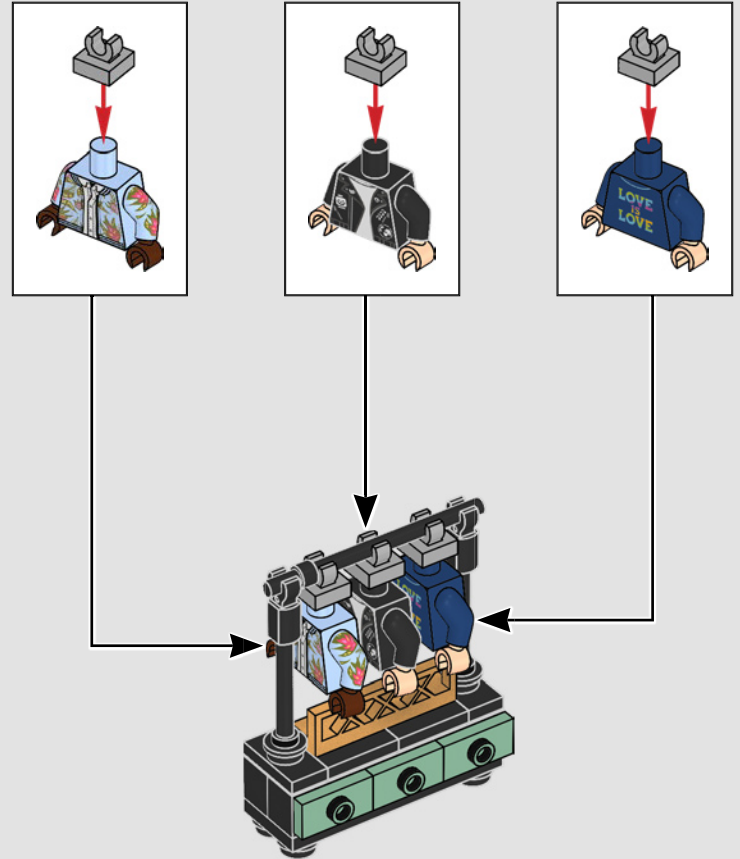

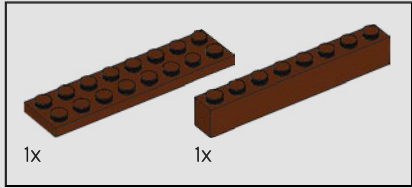

1

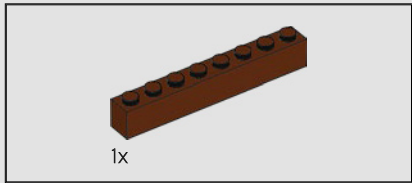
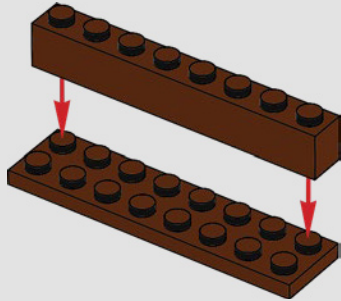

2

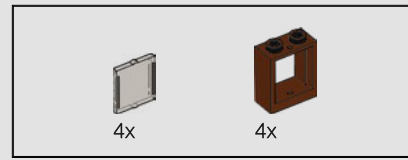
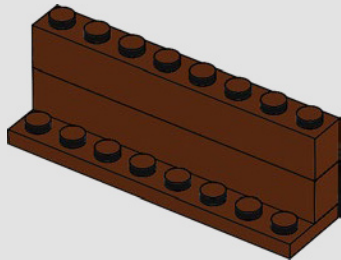

3

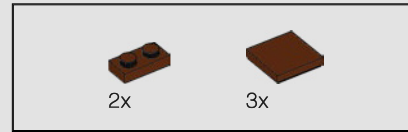
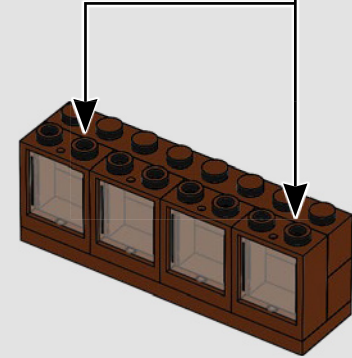
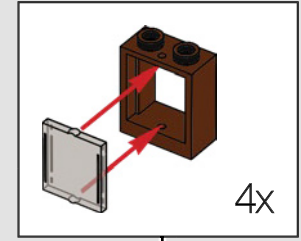

4

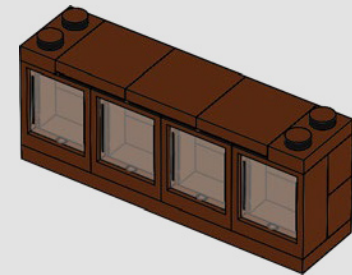



5

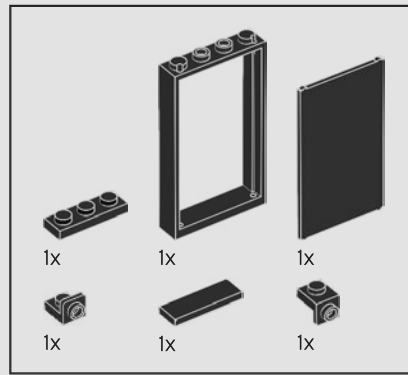
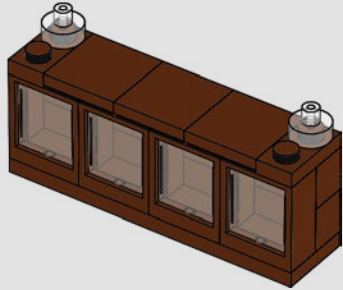

6

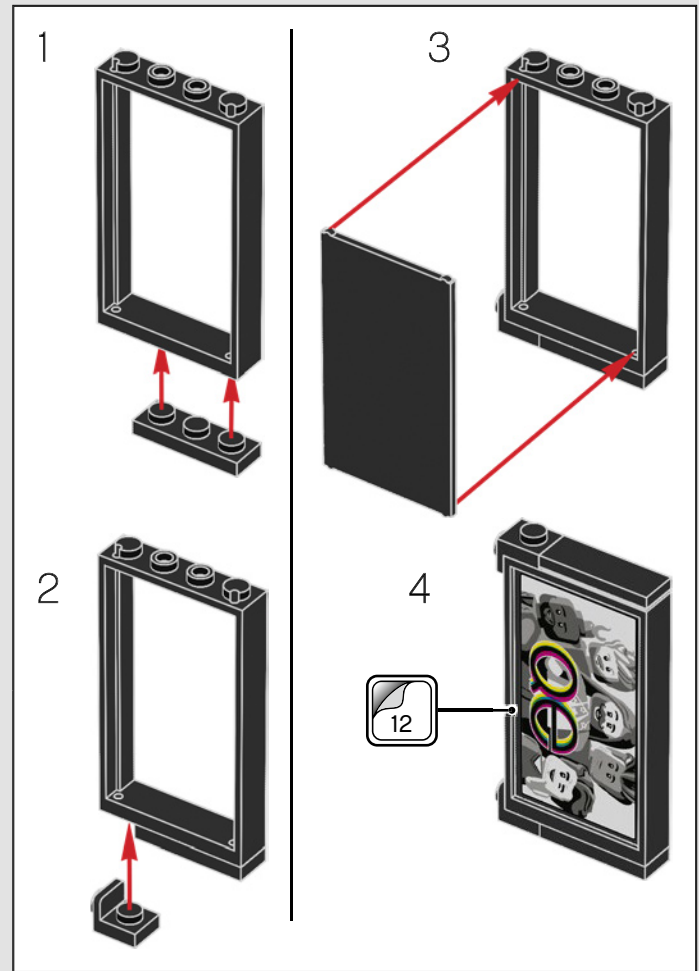
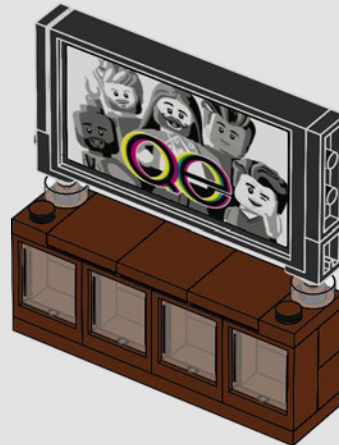

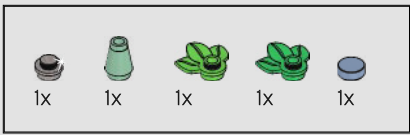

7



Jonathan Van Ness

"It's so important that folks have inclusion built into their creativity. So, for the LEGO Company to show support for topics like LGBTQ inclusivity feels necessary and I'm excited that it is happening."

« Il est tellement important que les gens intègrent l'inclusion à leur créativité. Je suis donc vraiment heureux de voir que la société LEGO montre son soutien à des sujets comme l'inclusivité à l'égard de la communauté LGBTQ. »

"Es importante que la inclusión forme parte de la creatividad de las personas. Por eso, el hecho de que una empresa como LEGO muestre su respaldo por temas como la inclusión de la comunidad LGBTQ es algo necesario, y me emociona que esté sucediendo".

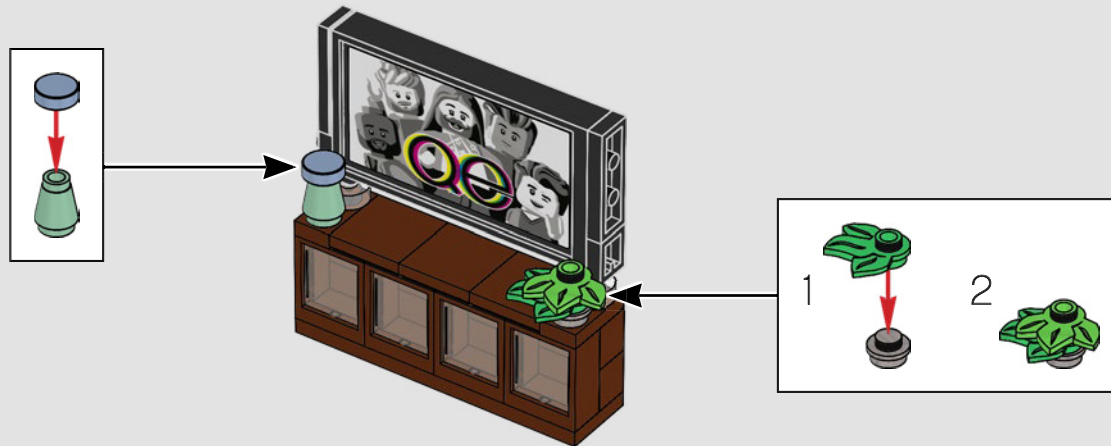

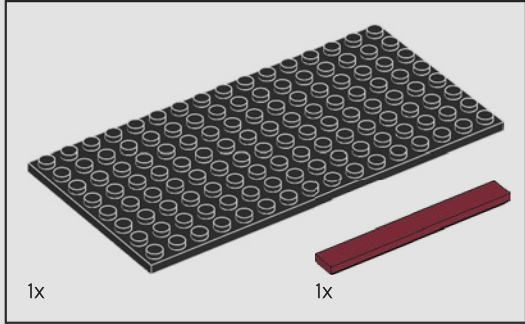
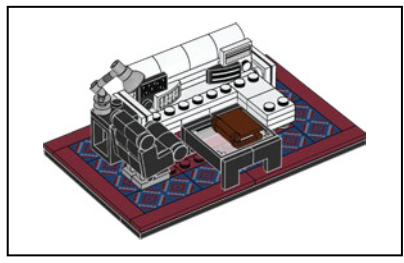

1

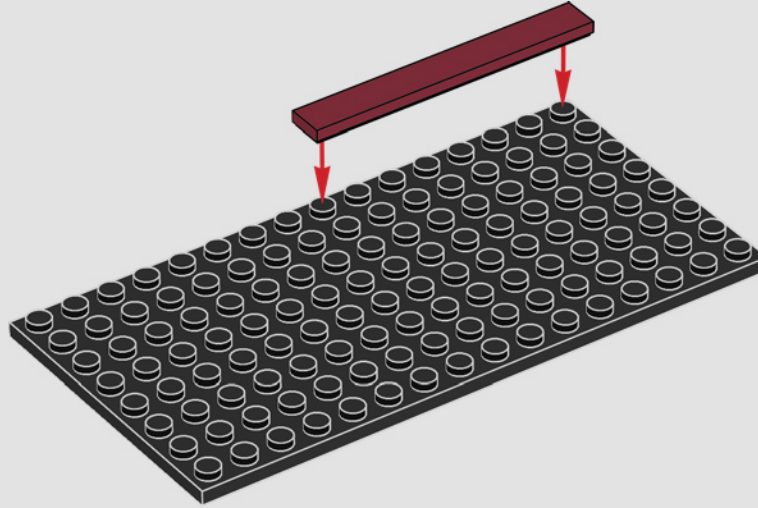

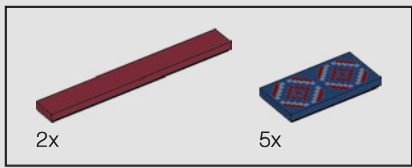

2

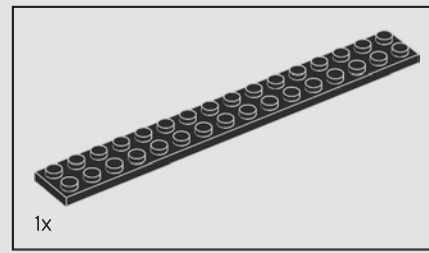
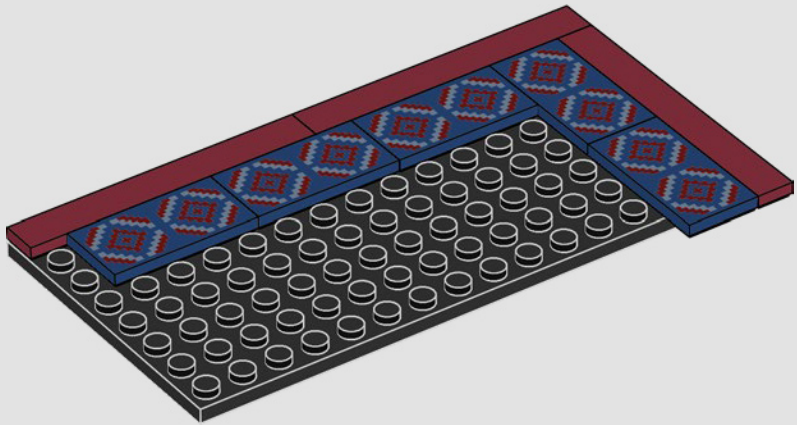

3

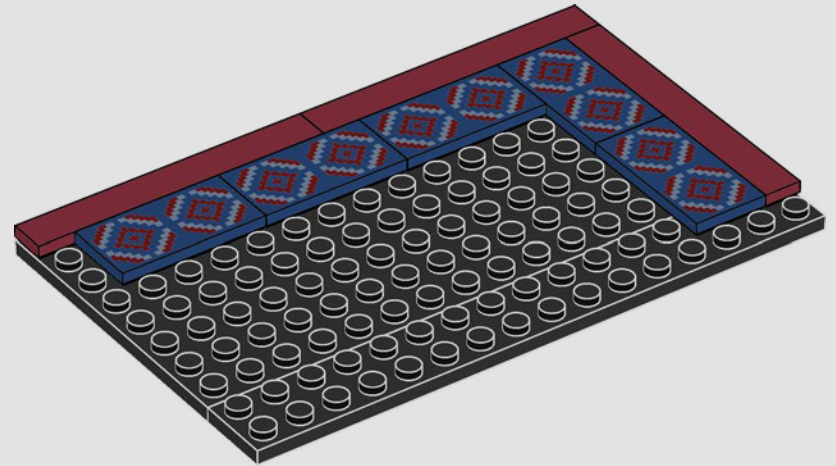



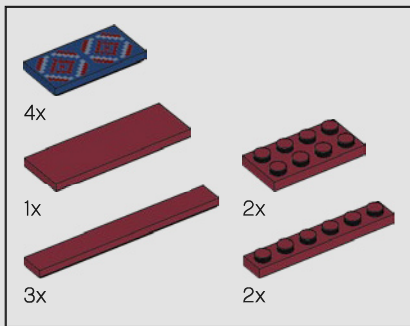

4

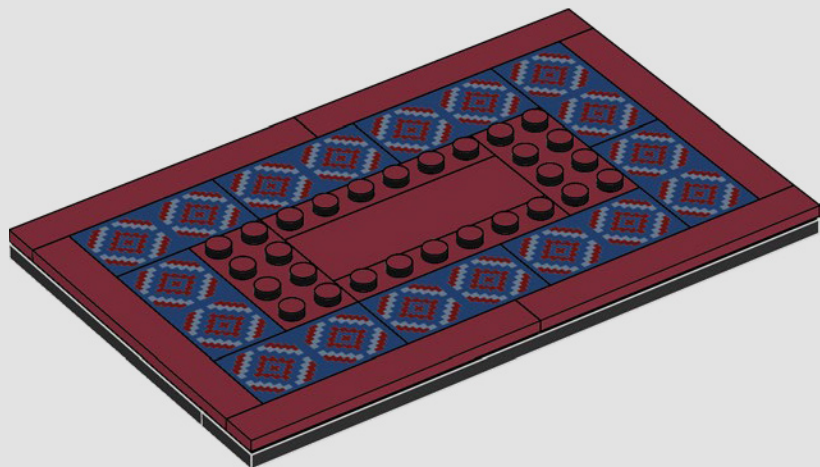

Jonathan Van Ness

*"To be a part of the imagination of folks creating a better world is lovely! I hope folks can spark their imagination with this collaboration."*

*« C'est incroyable de faire partie de l'imaginaire de gens qui créent un monde meilleur ! J'espère que cette collaboration saura éveiller l'imagination des gens. »*

*"¡Es maravilloso estar en la imaginación de quienes se ocupan de crear un mundo mejor! Espero que esta colaboración contribuya a echar a andar la imaginación de todos".*

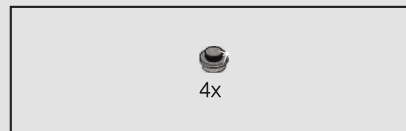

5

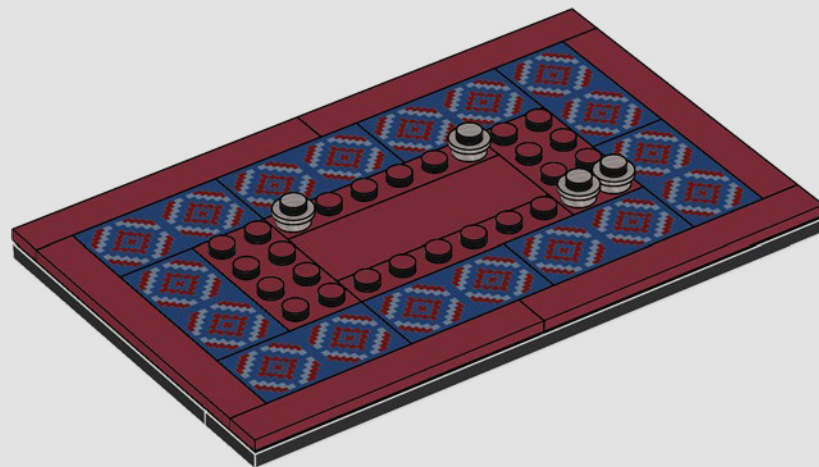

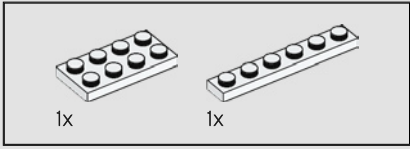
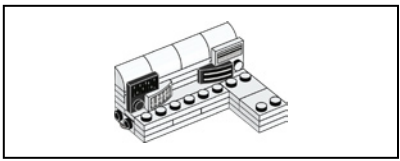

6

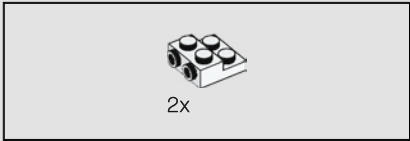
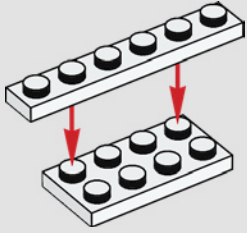

7

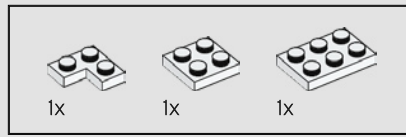
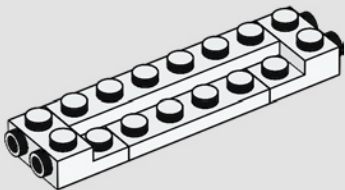

8

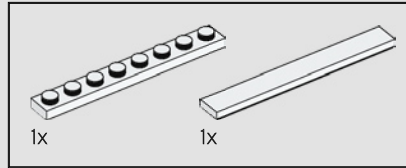
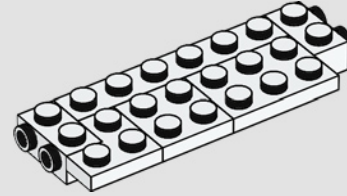

9

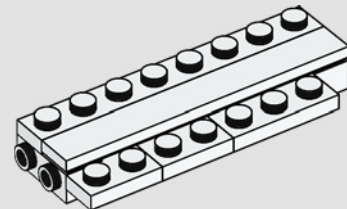

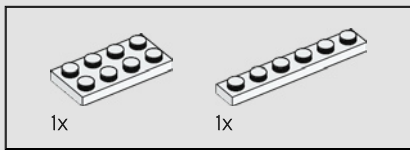

10

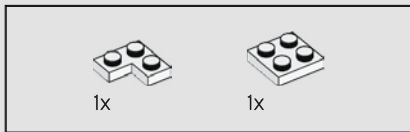
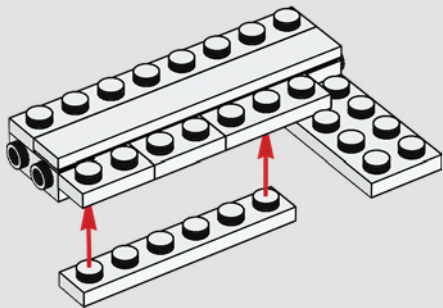

11

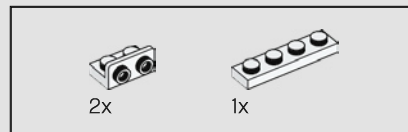
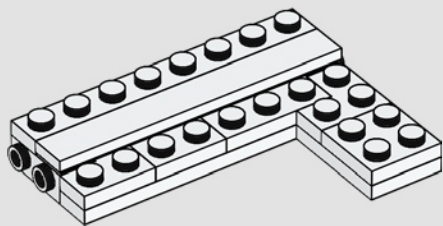

12

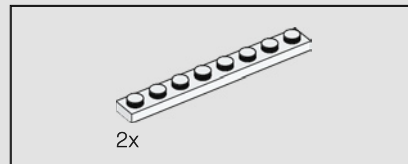
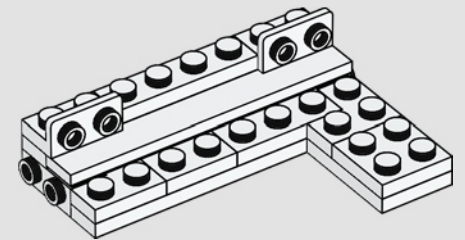

13

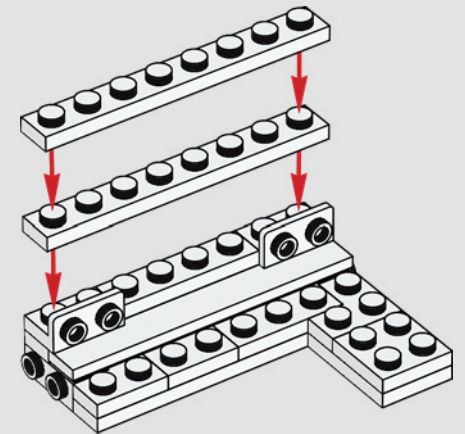

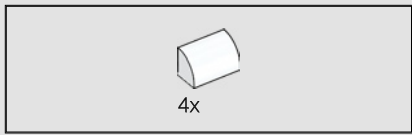

14

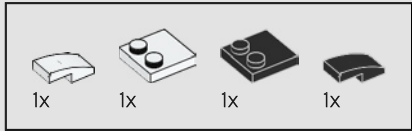
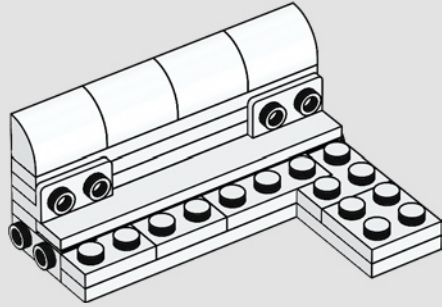

15

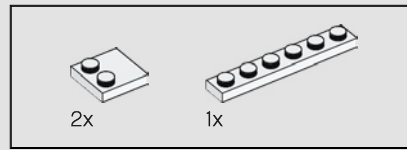
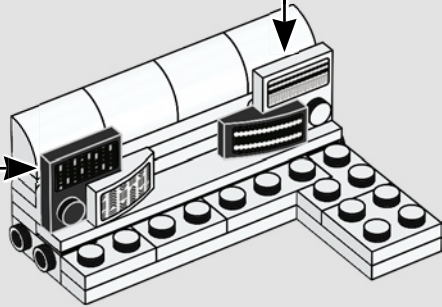
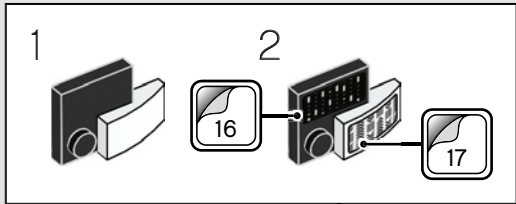
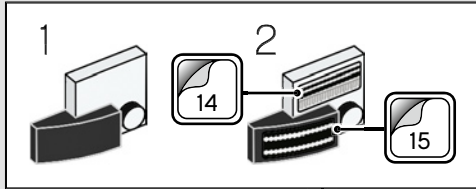

16

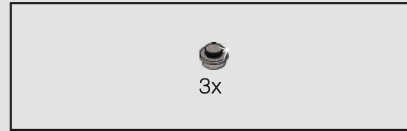
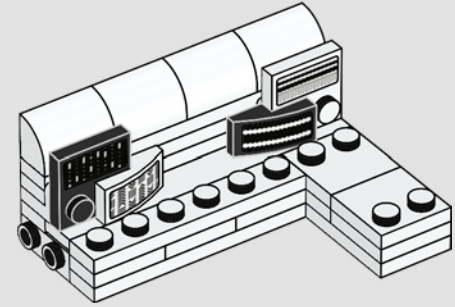

17

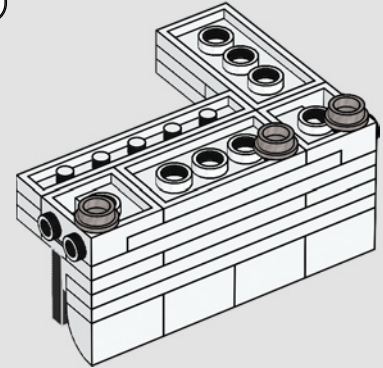
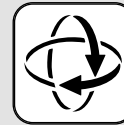

18

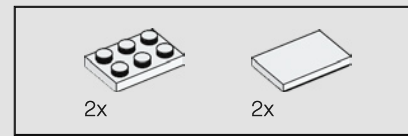
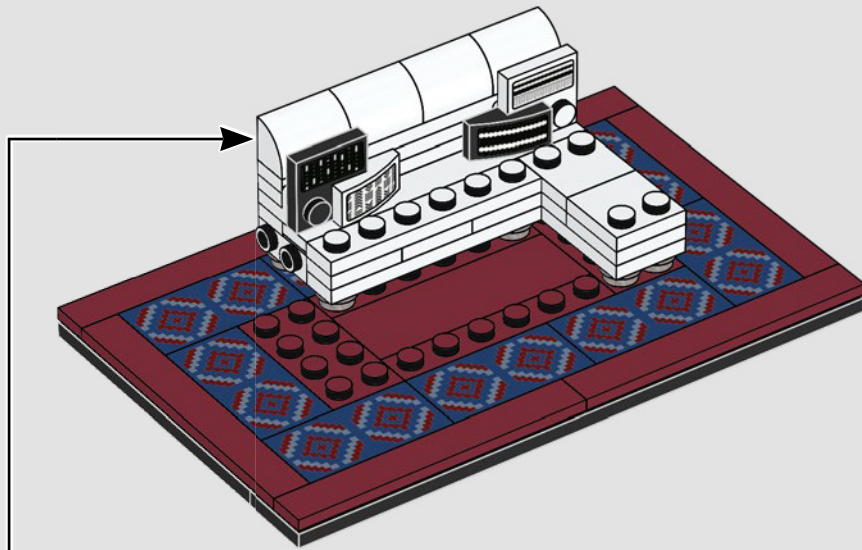

19

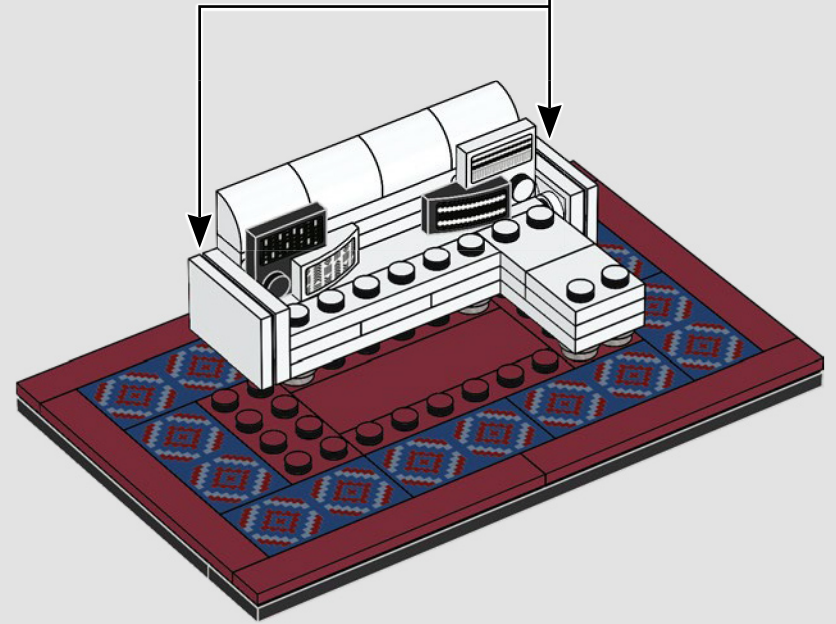
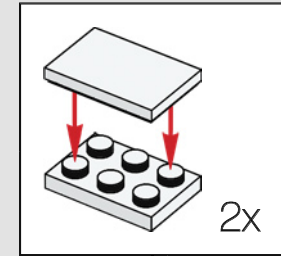

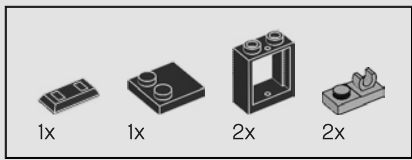

20

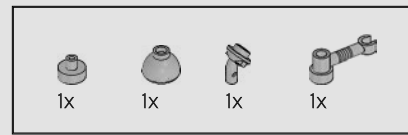
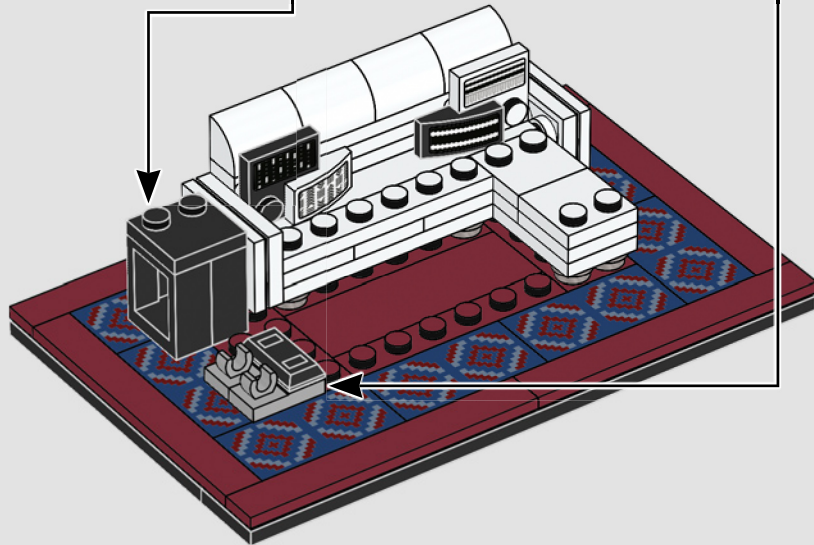
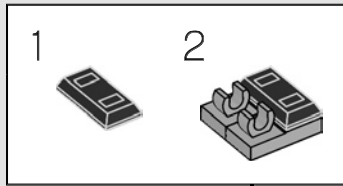
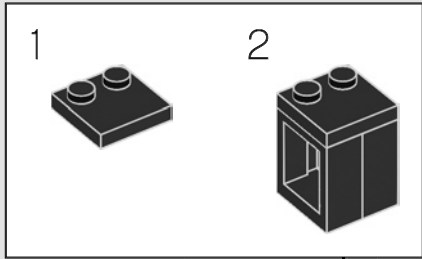

21

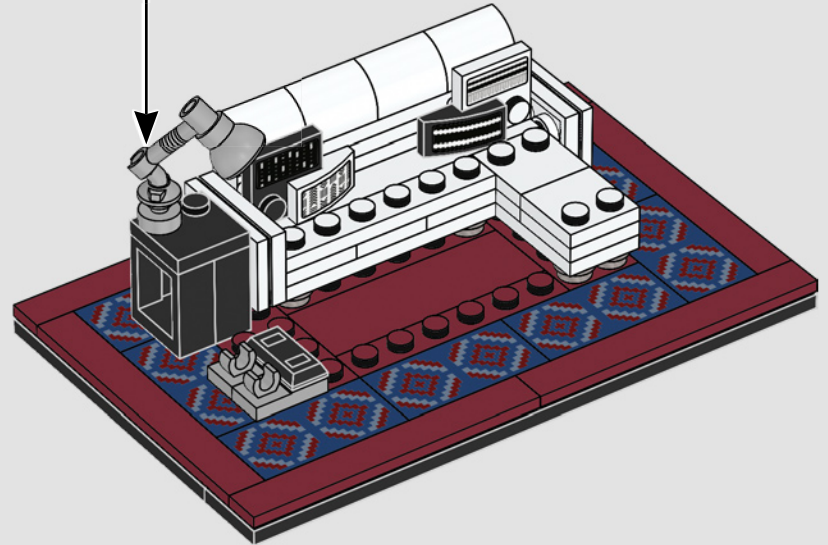
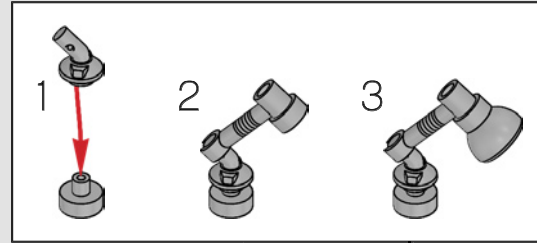

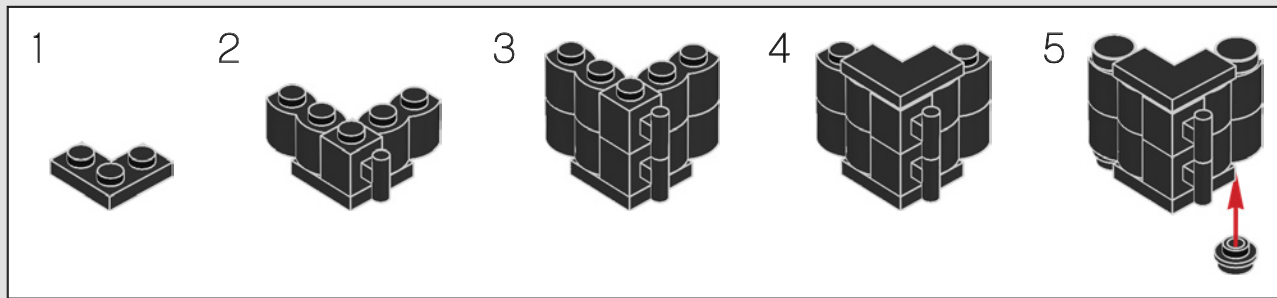
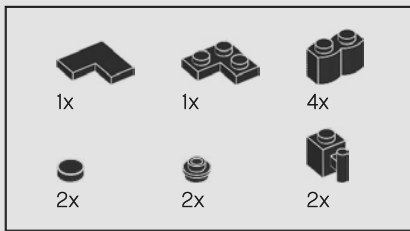

22

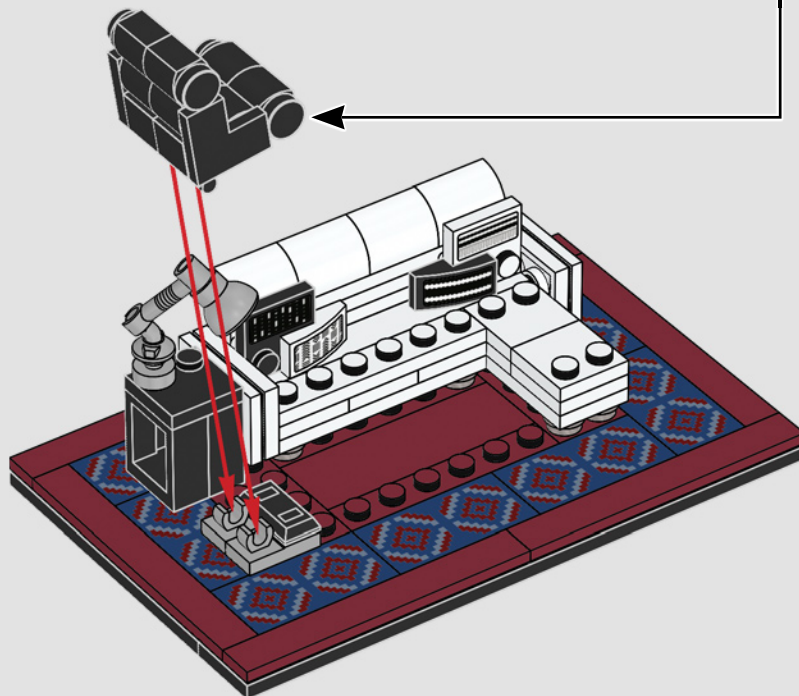

Tan France

"I love a creative process, and LEGO® is perfect for unleashing that creativity, you can build whatever you want in your own unique style."

« J'aime avoir un processus créatif, et LEGO® est parfait pour libérer cette créativité; vous pouvez construire ce que vous voulez dans un style bien à vous. »

"Me encanta el proceso creativo, y LEGO® es ideal para liberar tu creatividad: puedes construir cualquier cosa que quieras con el estilo personal que te hace único".





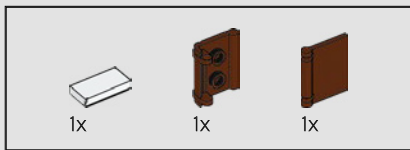

24

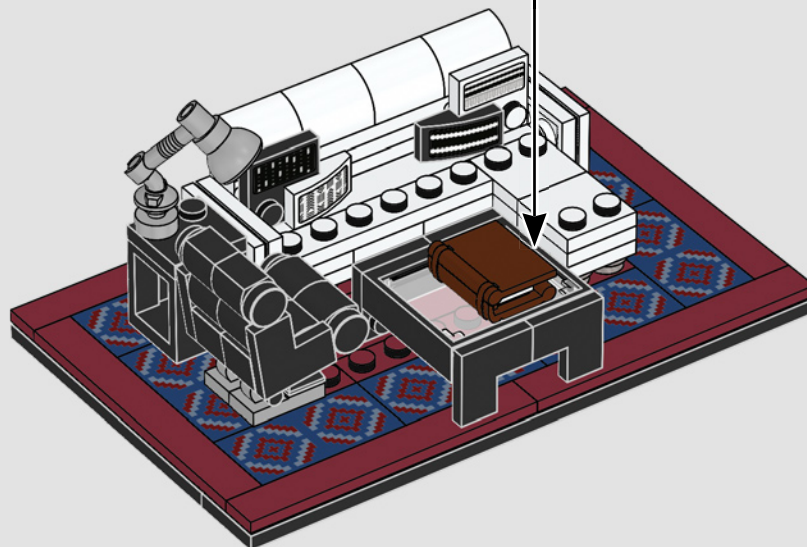
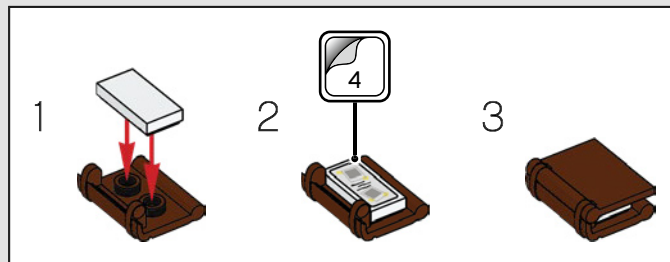

Karamo Brown

"Seeing this set is bringing back so many happy memories. It's like I have been shrunk down to a miniature scale and I can relive the show all over again!"

« La vue de cet ensemble me rappelle tellement de bons souvenirs. C'est comme si j'avais été réduit à une échelle miniature et que je pouvais revivre l'émission une seconde fois ! »

"Ver el set me trae de vuelta muchísimos recuerdos felices. ¡Es como si me hubieran reducido a escala miniatura y pudiera vivir una vez más cada hermosa experiencia que pasé en el programa!"

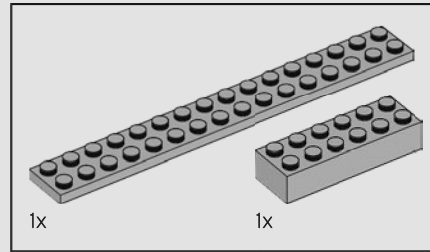
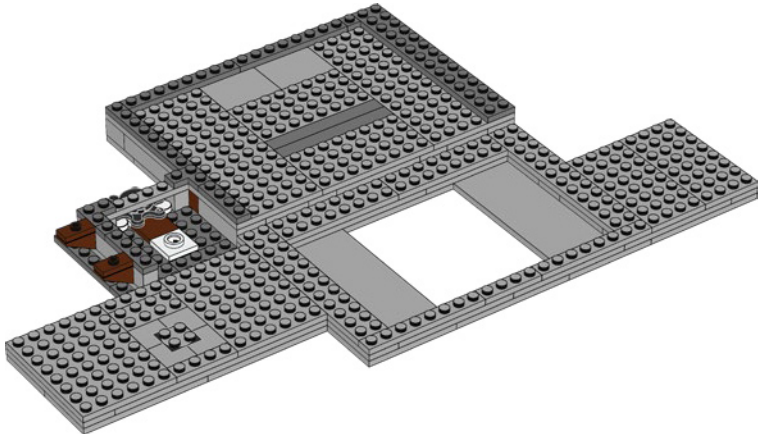
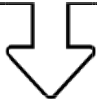

1

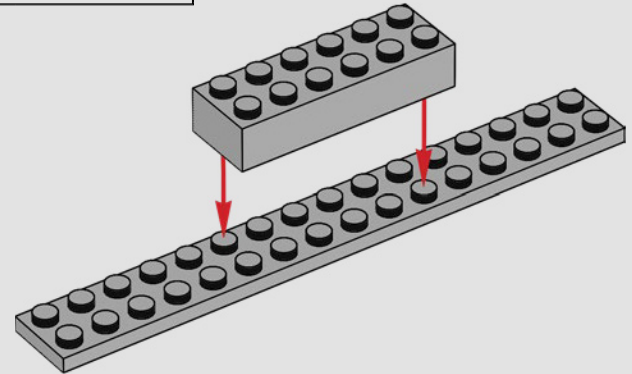

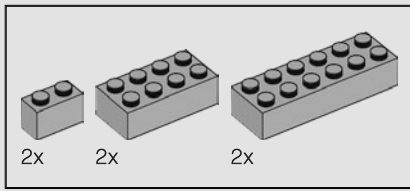

2

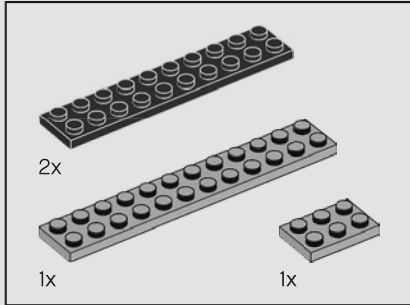
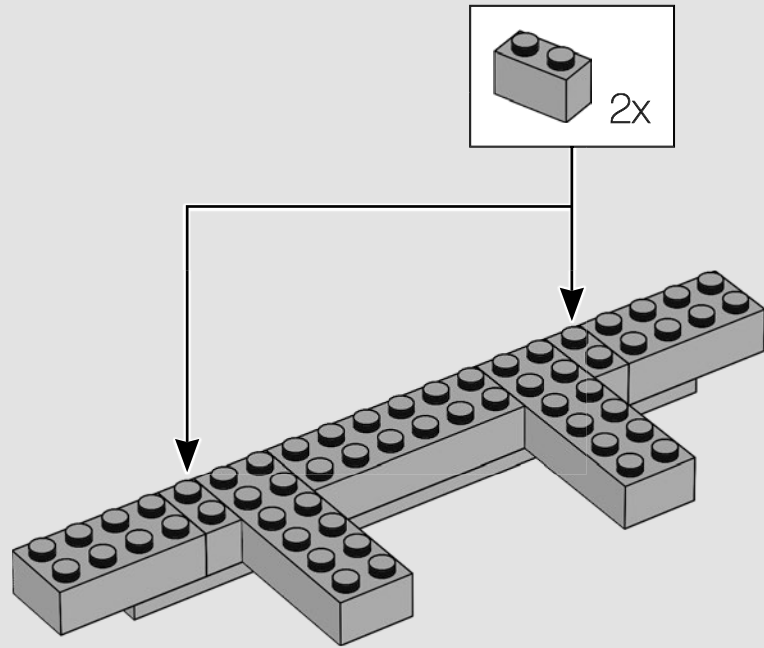

3

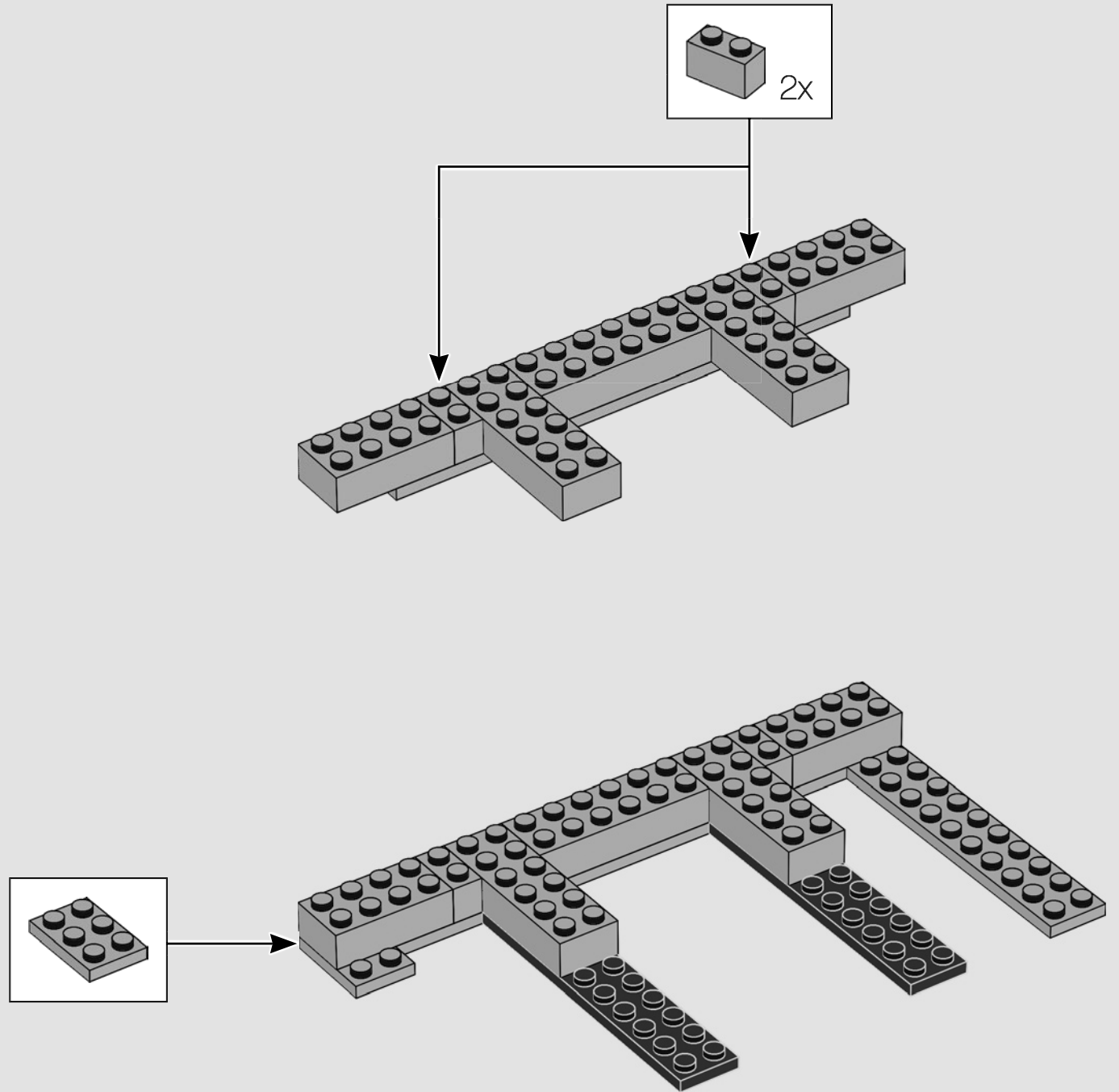

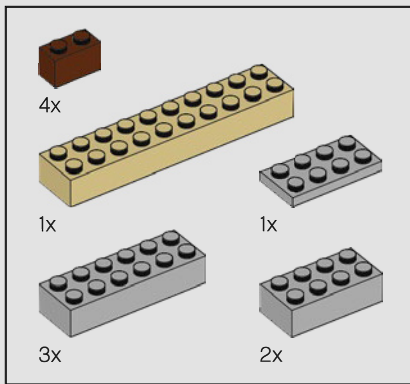

4

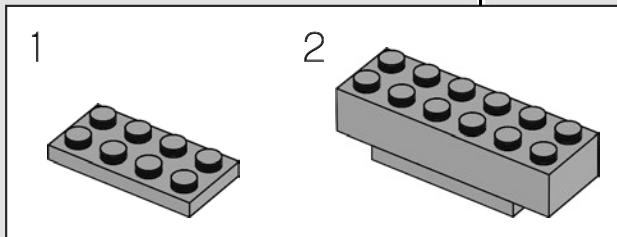
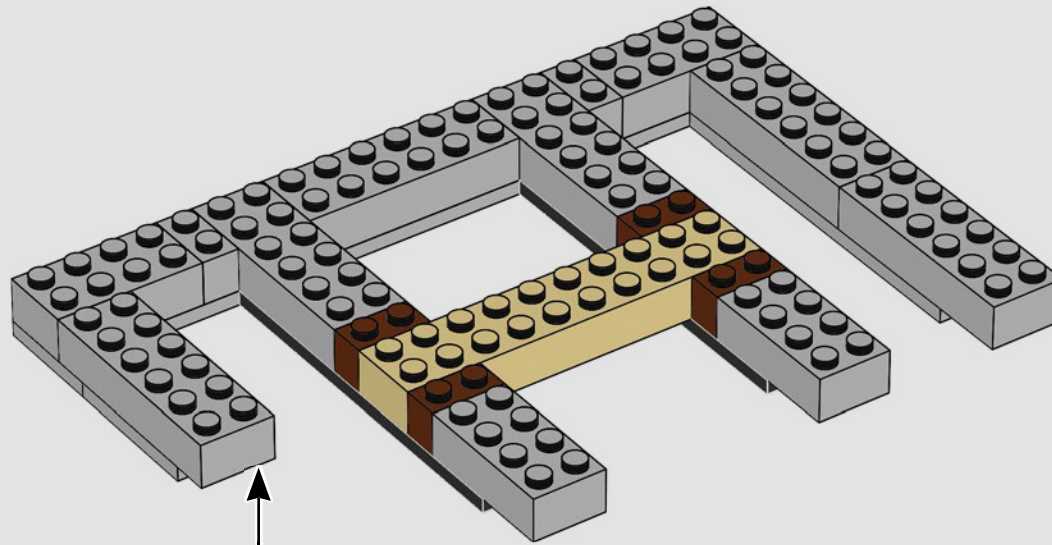

Karamo Brown

*"Queer Eye is special because of the people; the amazing cast I work with every day and the beautiful lives I get to touch and interact with on the show and share with the world."*

*« Ce sont les gens qui rendent l'émission Queer Eye si spéciale : la distribution formidable avec laquelle je travaille tous les jours et les vies incroyables que j'ai pu toucher et partager avec le monde. »*

*"Lo que hace especial a Queer Eye es la gente: el increíble elenco con el que trabajo todos los días y las hermosas vidas en las que tengo la oportunidad de influir y con las que puedo interactuar en el programa y compartir el mundo".*

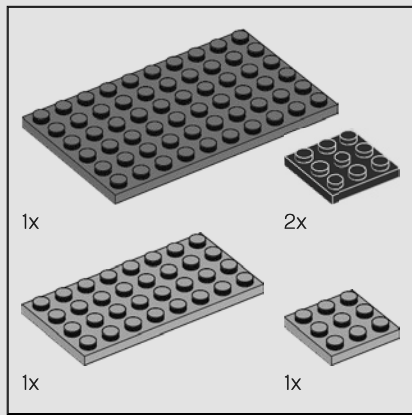

5

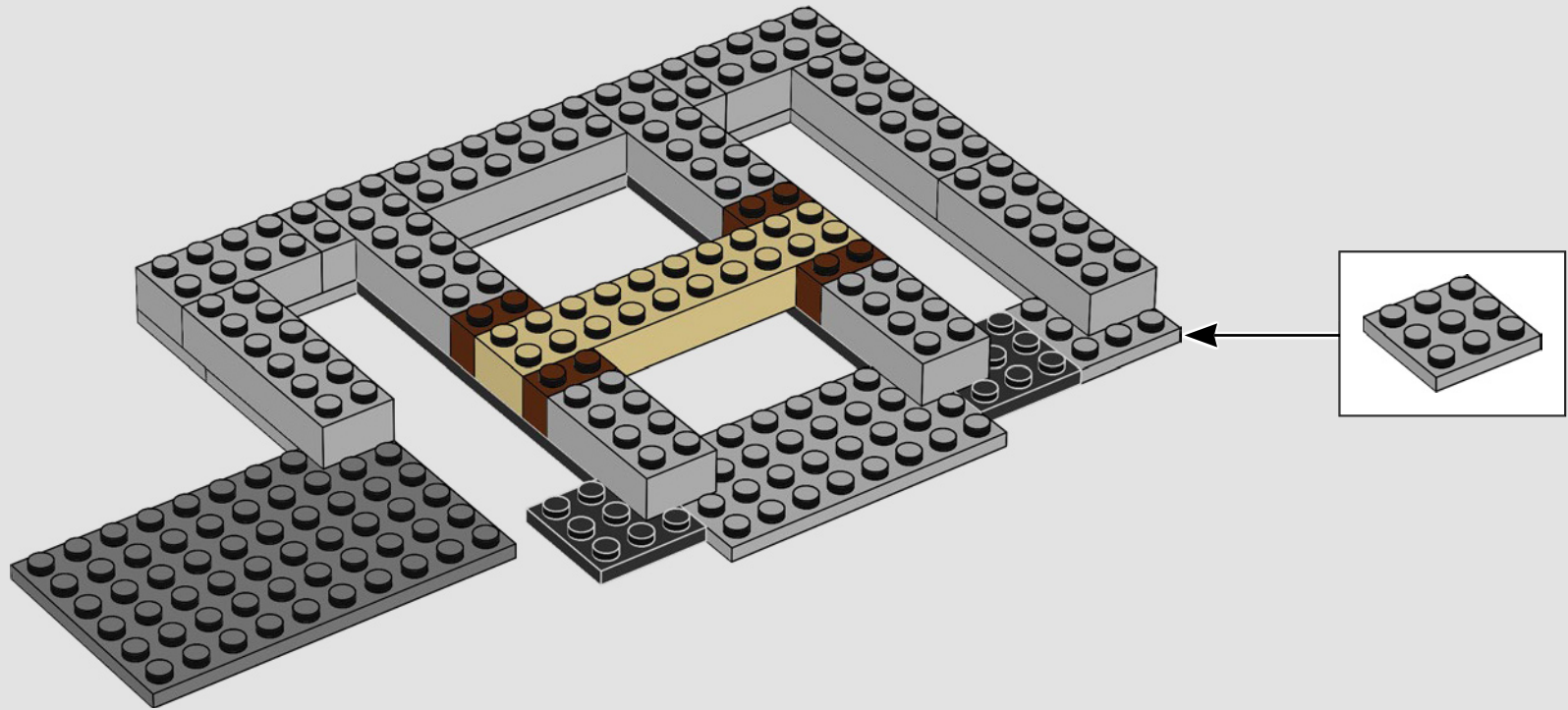

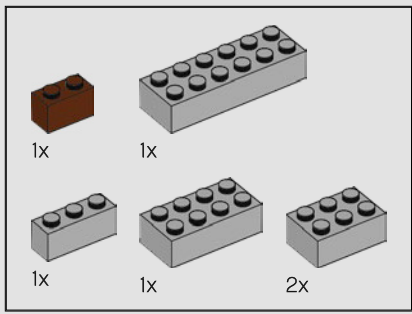

6

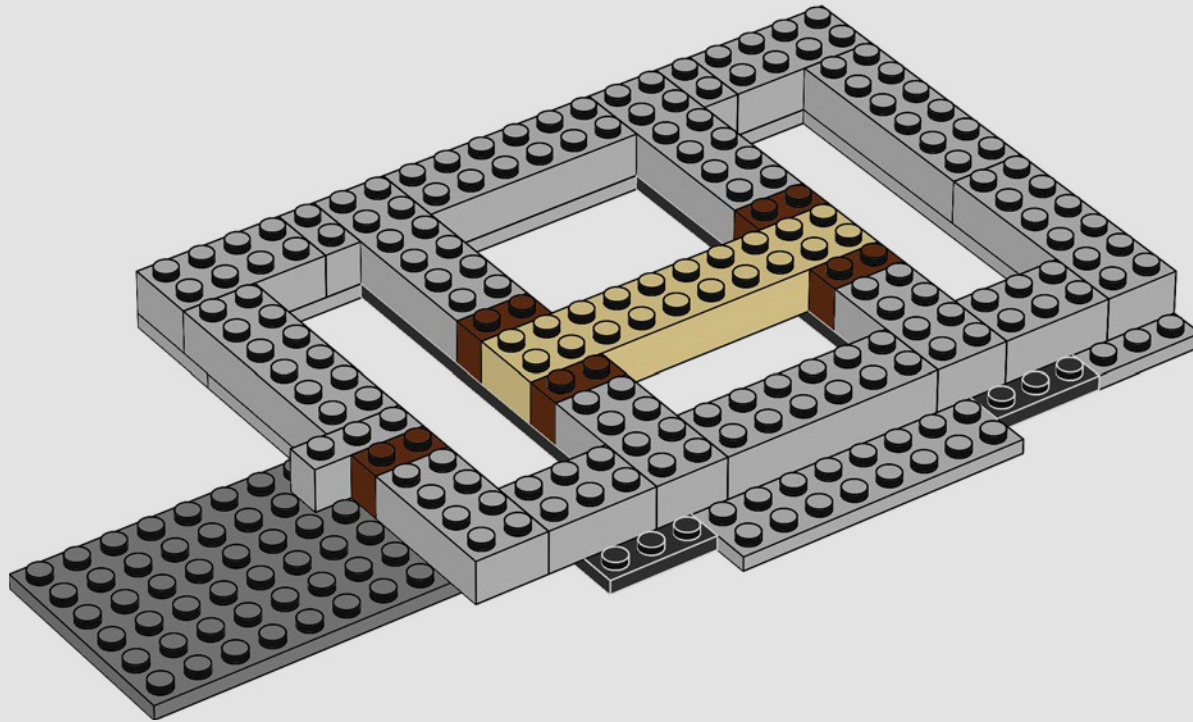

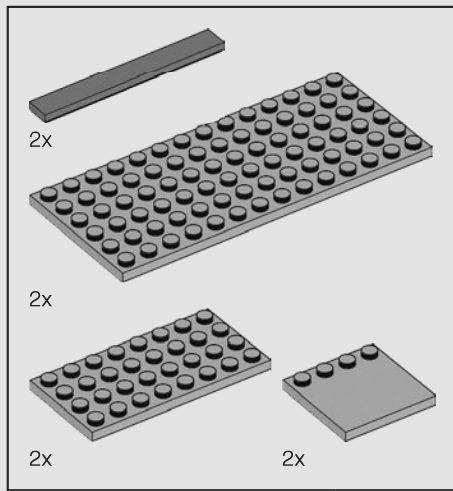

7

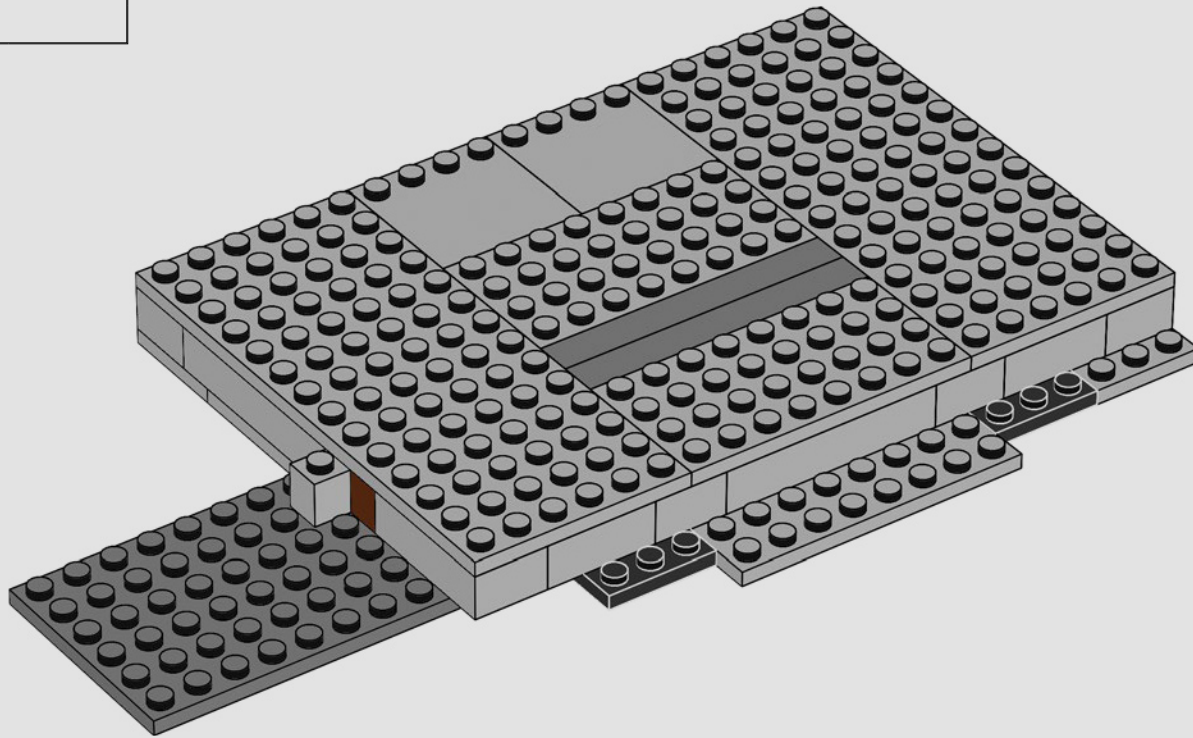

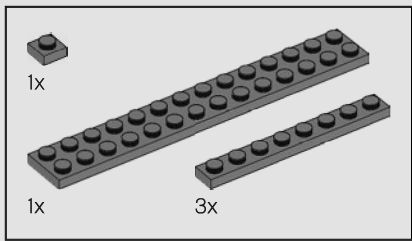

8

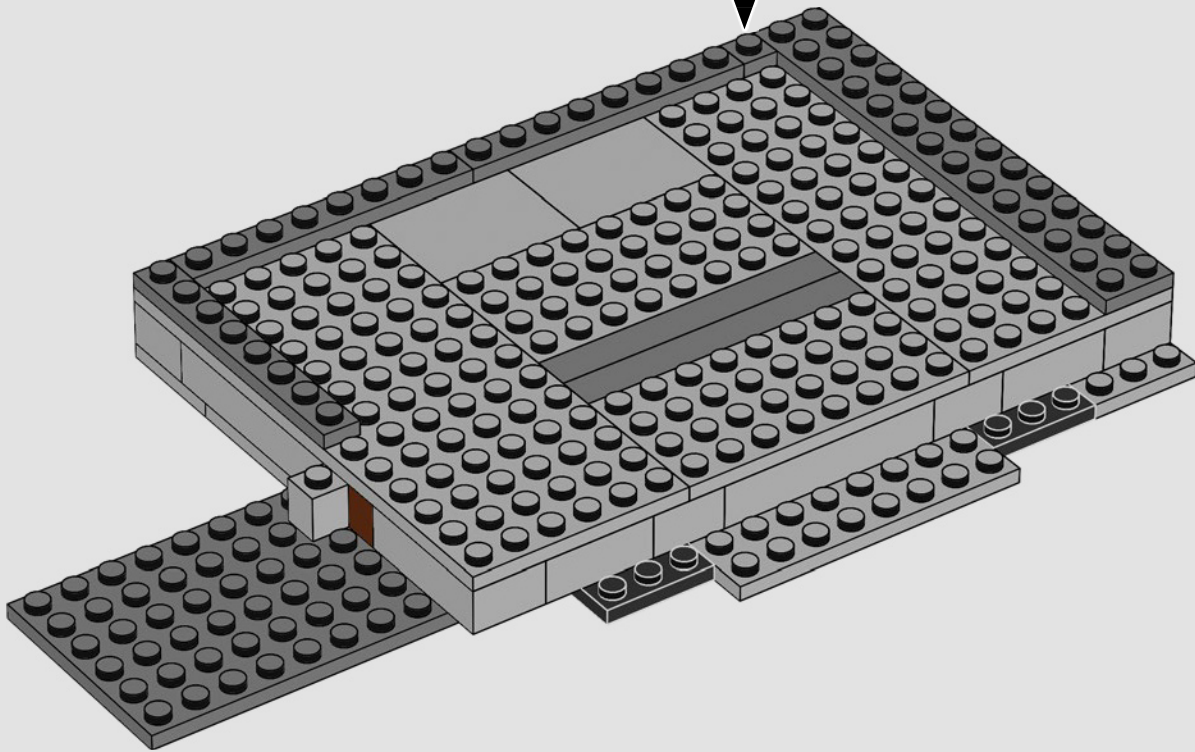
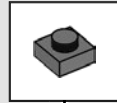



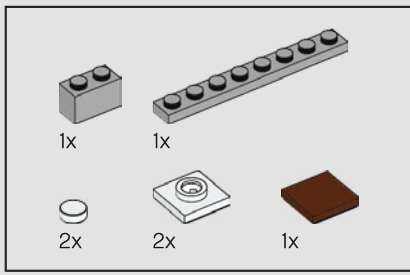

9

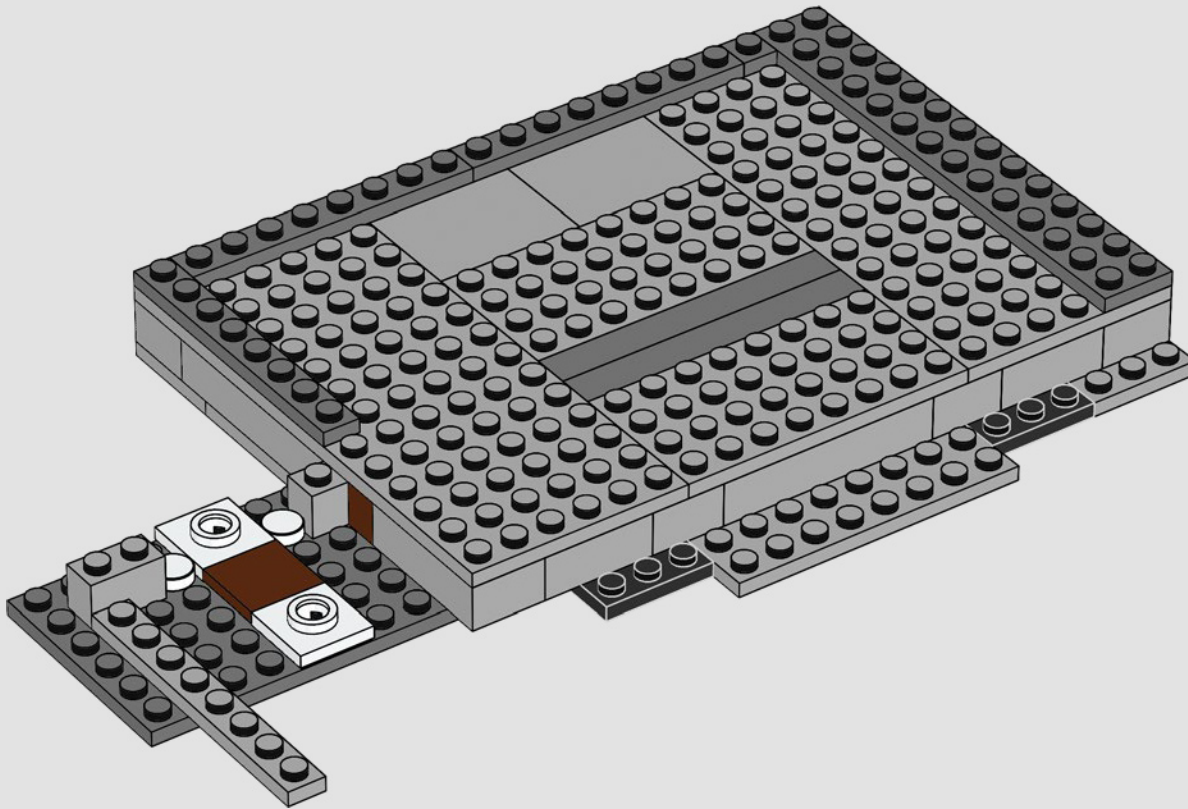

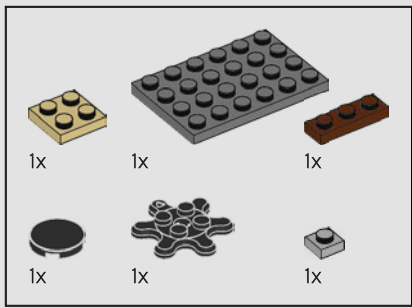

10

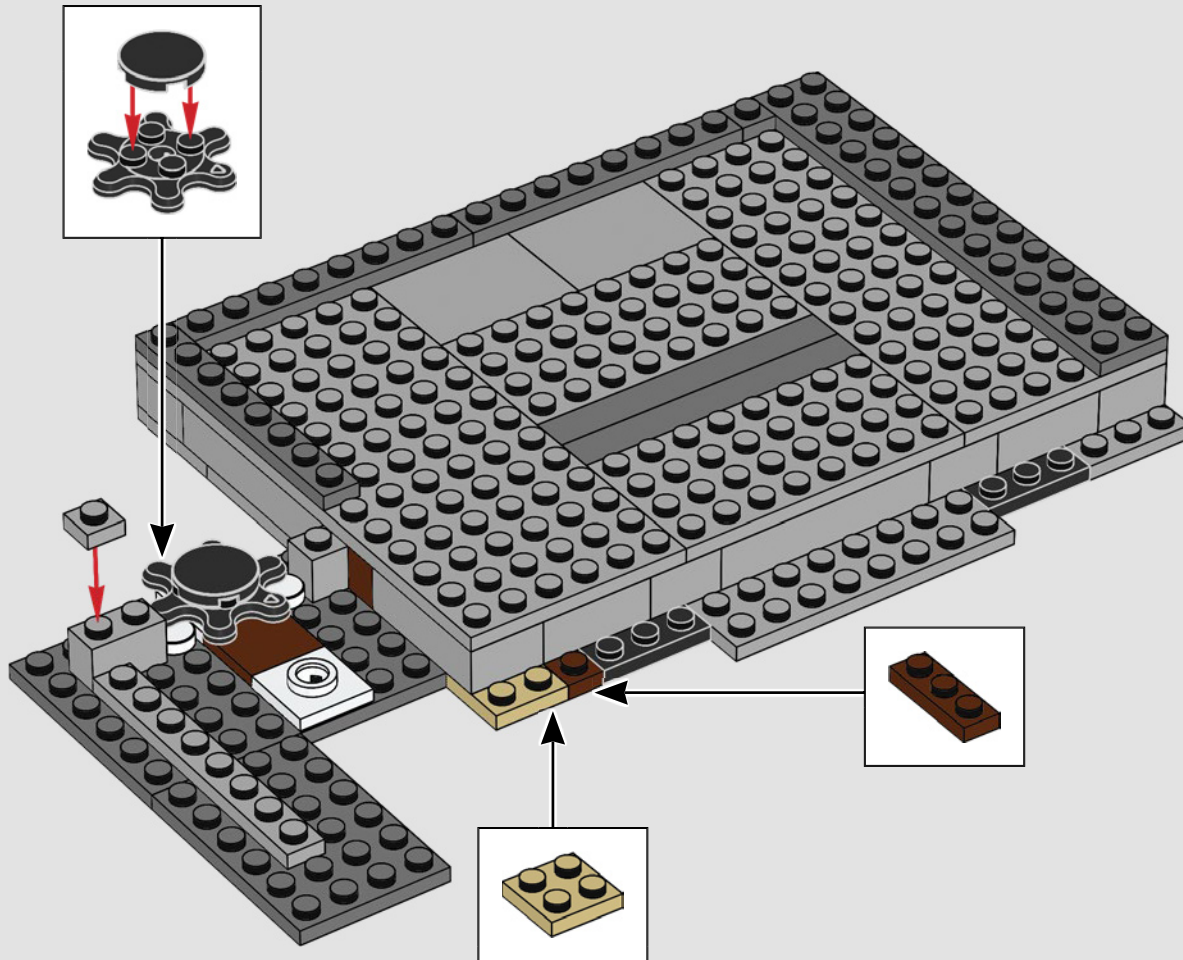

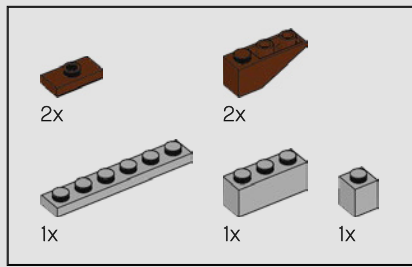

11

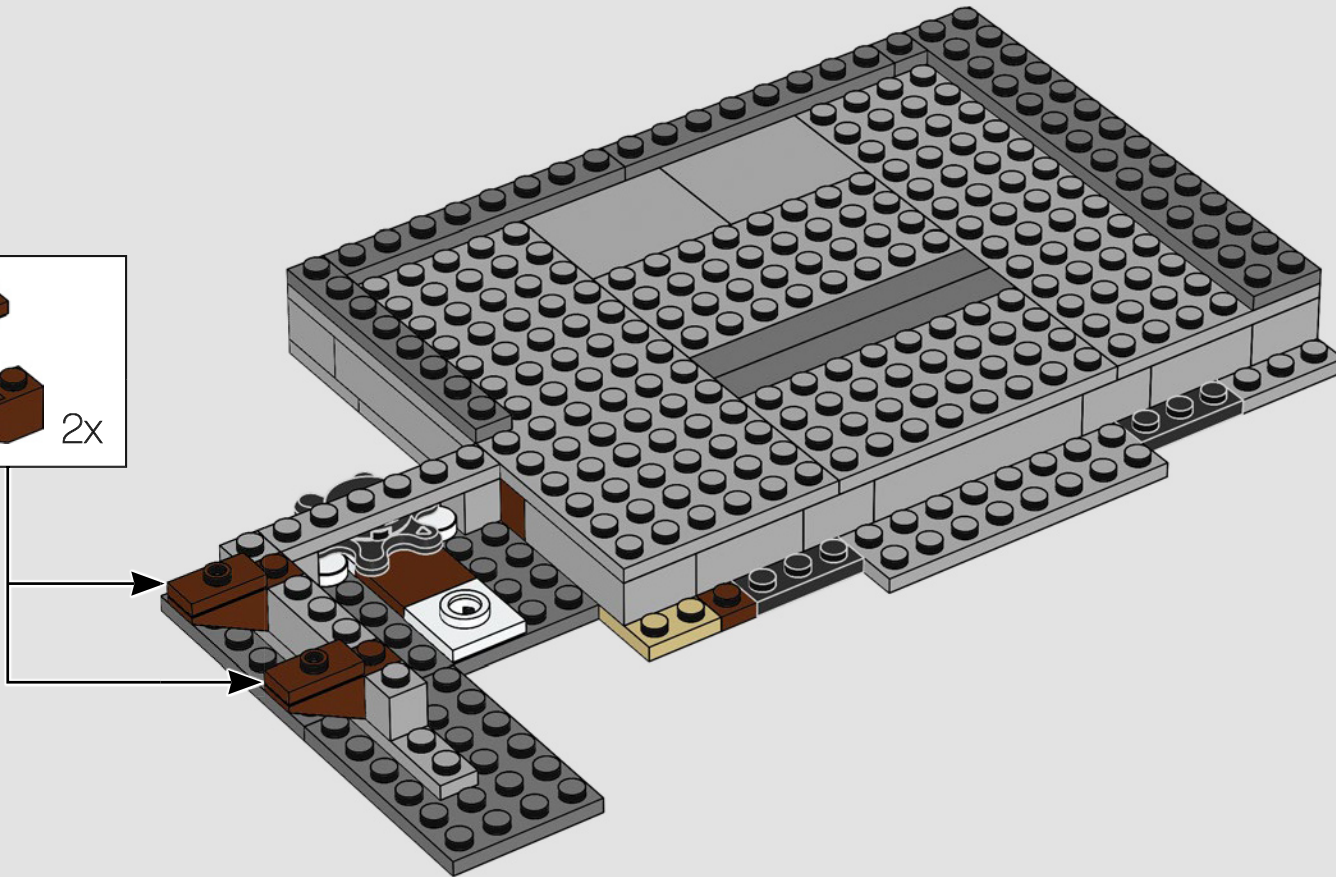
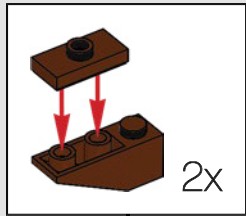

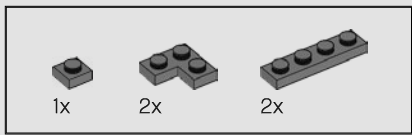

12

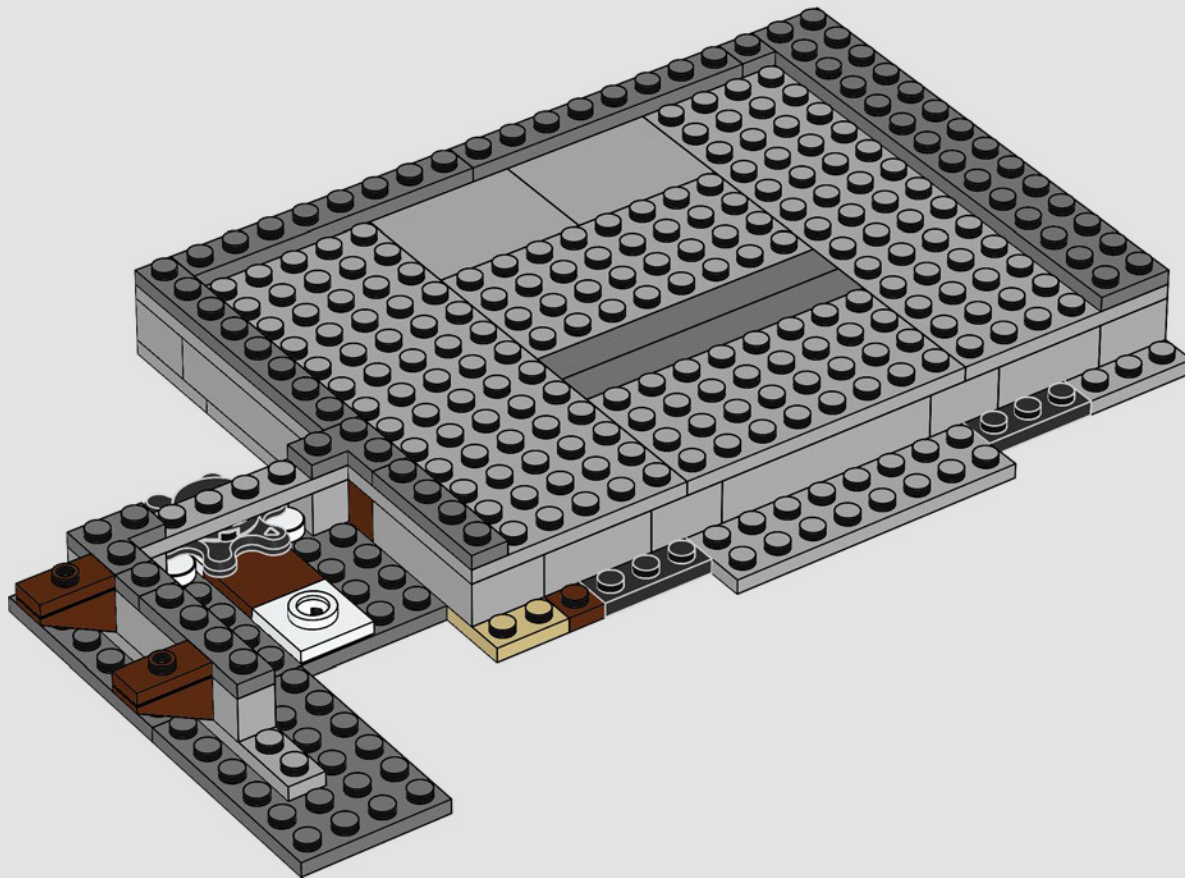

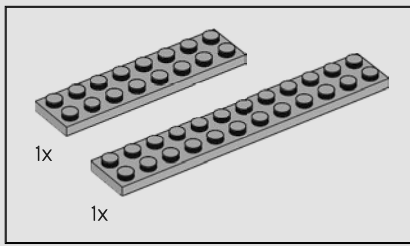

13

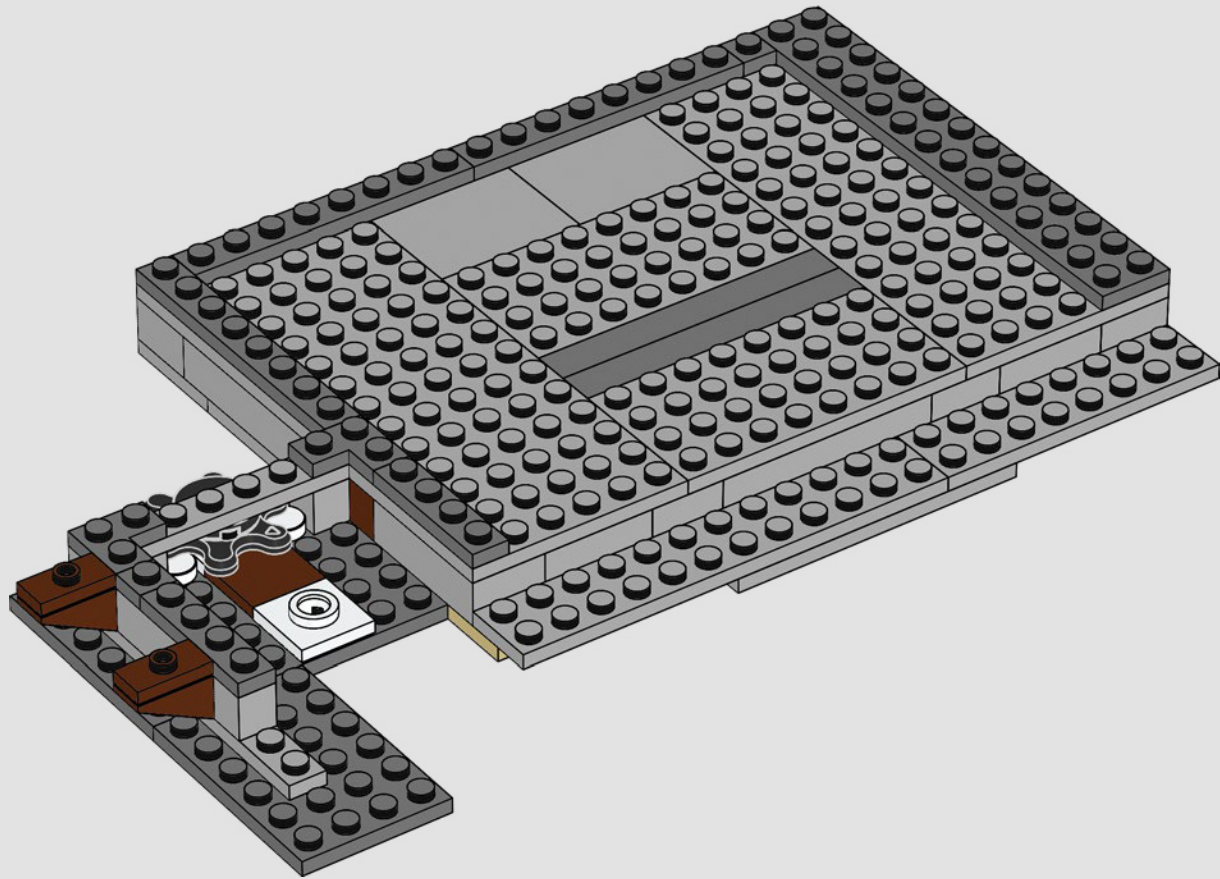

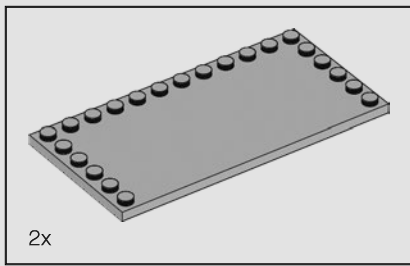

14

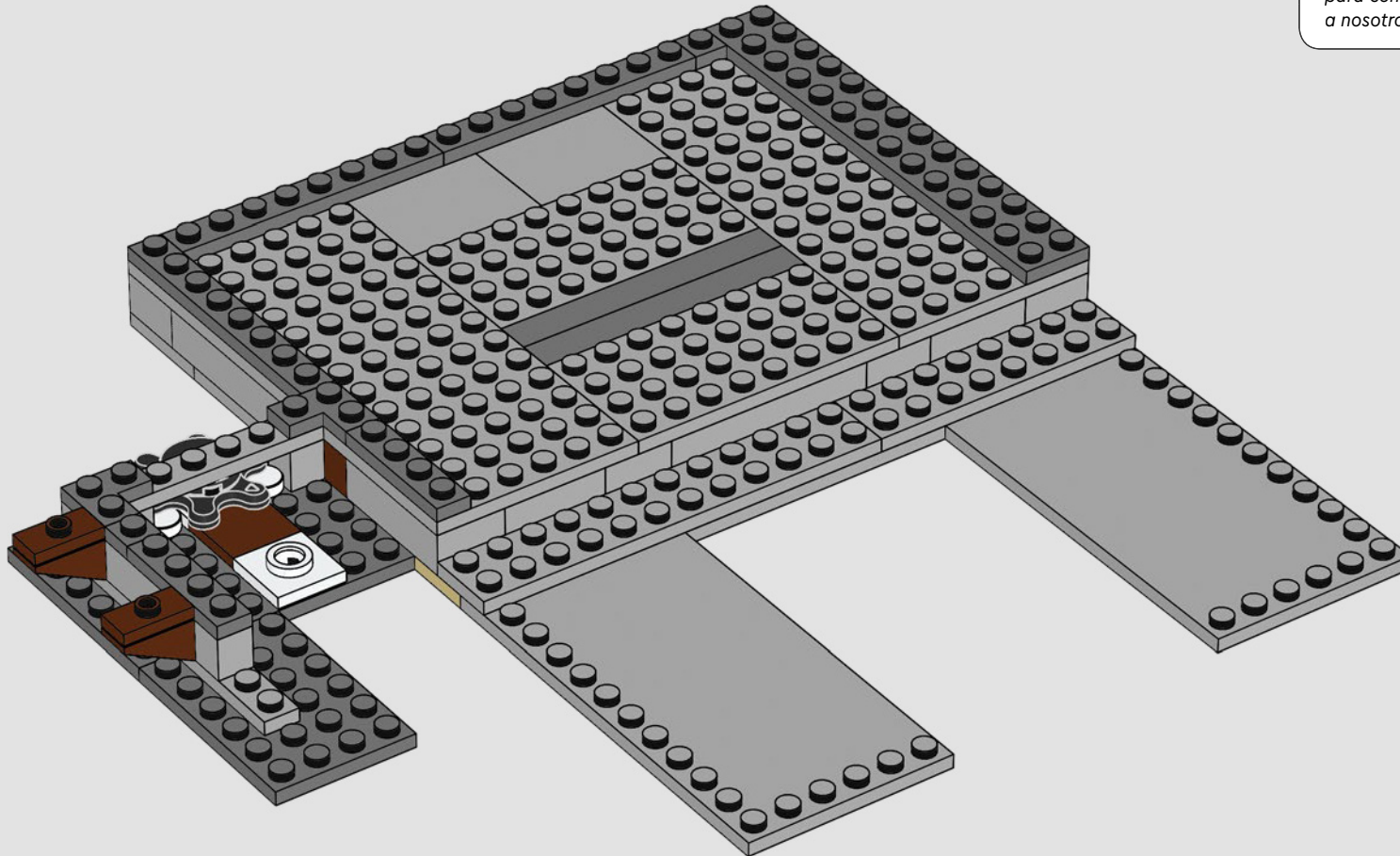

Jonathan Van Ness

*"My goal on Queer Eye is creating a legacy of connection and understanding, not only with those around us but also understanding and accepting ourselves, too."*

*« Mon but à Queer Eye est de créer un héritage d'acceptation et de compréhension, non seulement envers ceux qui nous entourent, mais aussi envers nous-mêmes. »*

*"Mi objetivo en Queer Eye es crear un legado de conexión y entendimiento, no solo hacia quienes nos rodean, sino también para comprendernos y aceptarnos a nosotros mismos".*

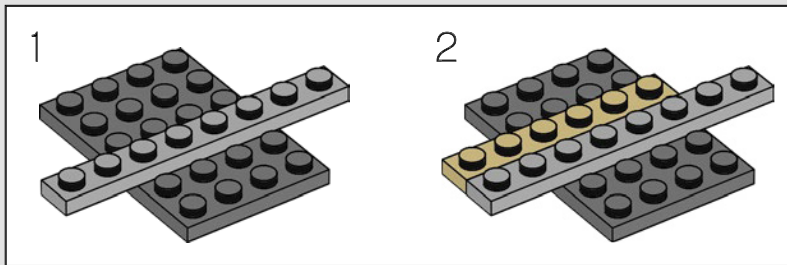
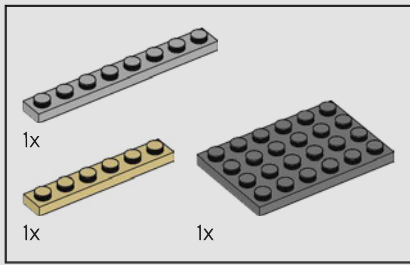

15

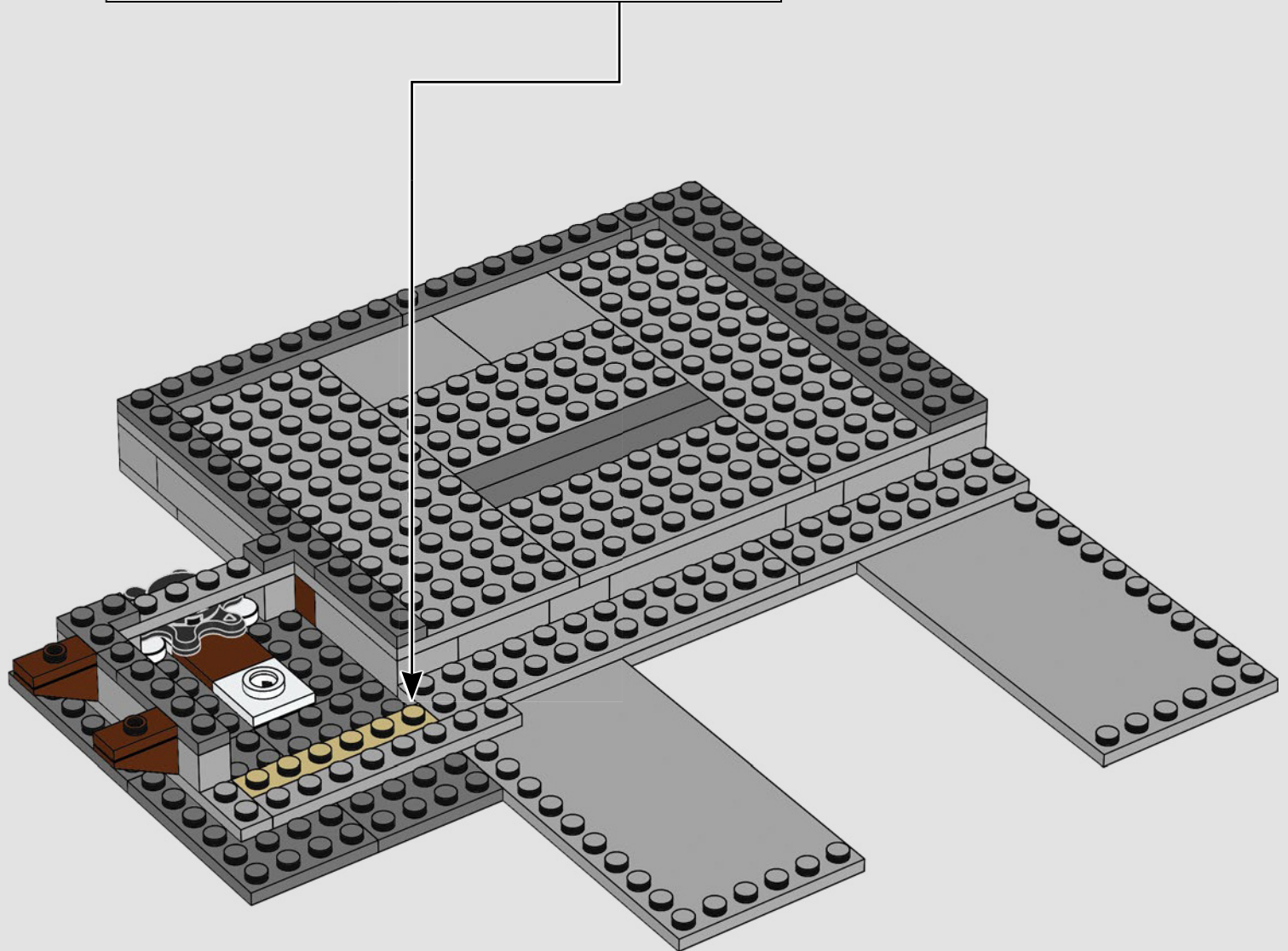

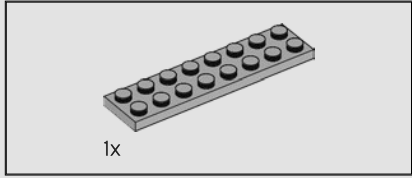
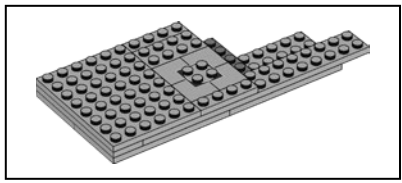

16

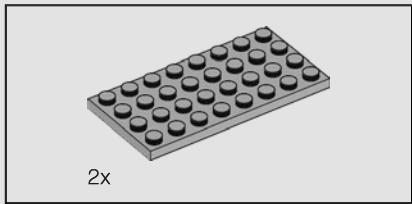
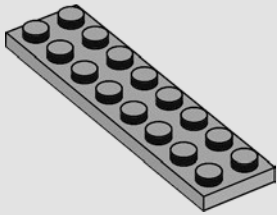

17

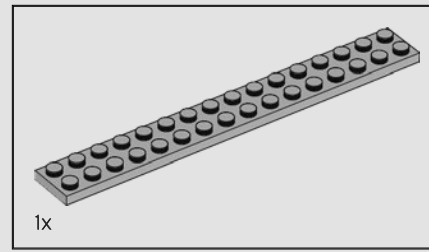
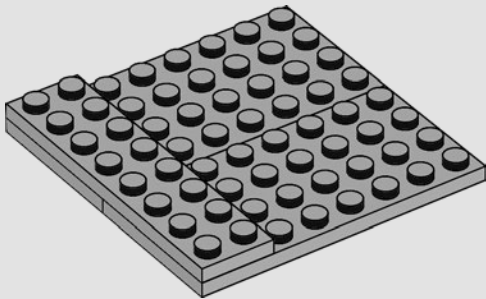

18

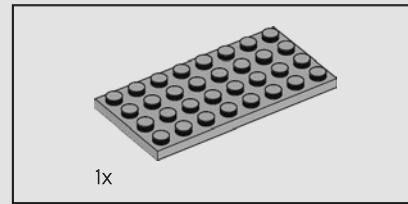
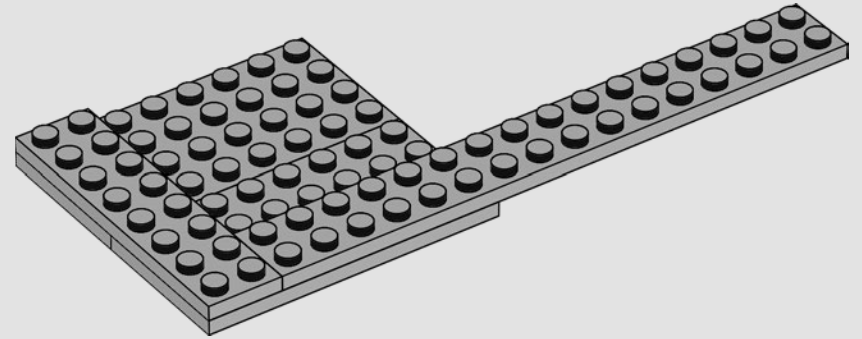

19

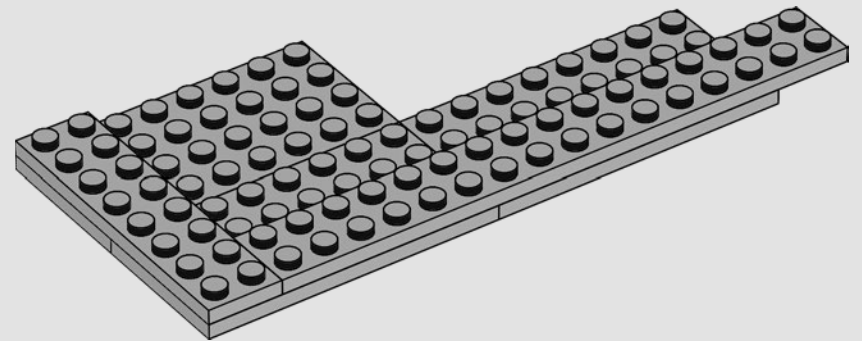



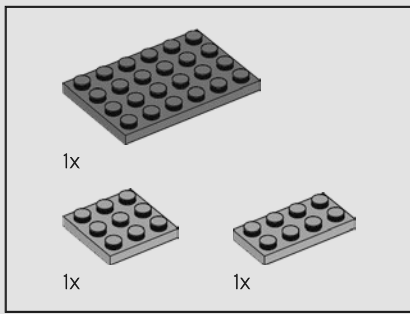

20

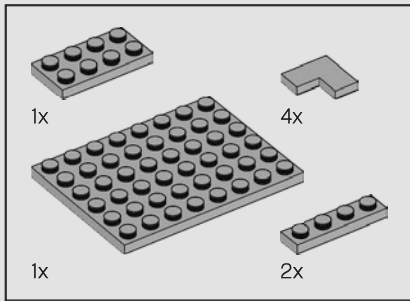
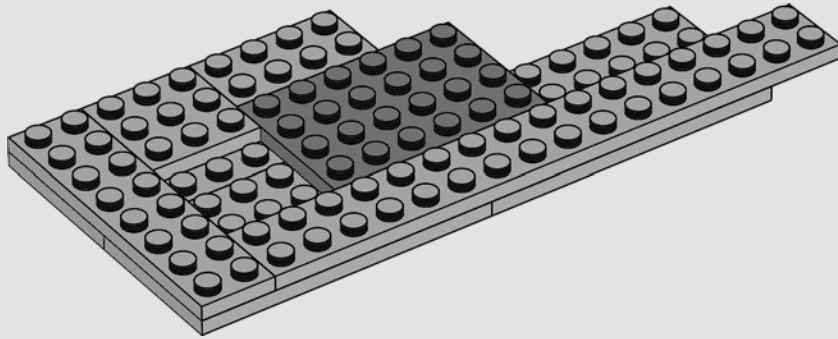

21

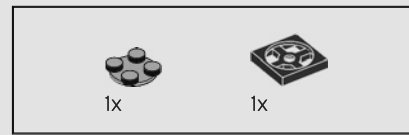
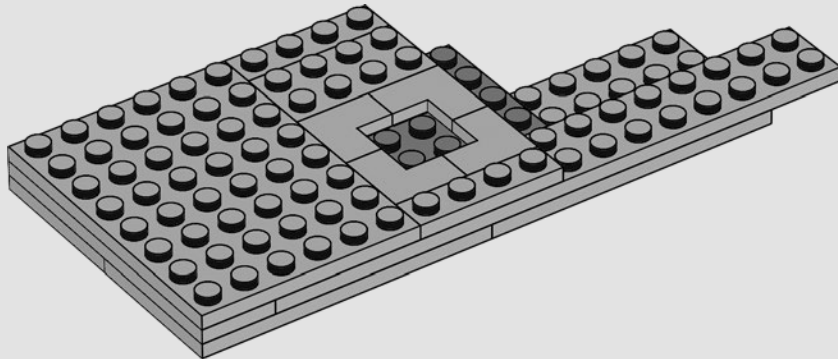

22

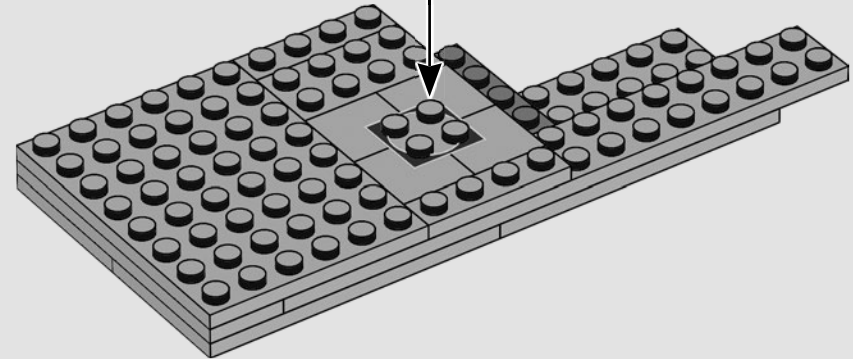
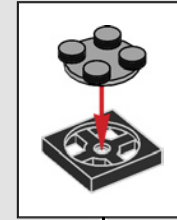



Karamo Brown

"LEGO® has been really special to me and my family. Not only has LEGO kept my boys entertained for hours, it has also been a great activity for me to connect and bond with them over even more."

« LEGO® a été très spécial pour moi et ma famille. Non seulement LEGO a diverti mes garçons pendant des heures, mais cela m'a également permis de passer du temps avec eux et de resserrer les liens qui nous unissent. »

"LEGO® ha sido algo muy especial para mí y para mi familia. No solo porque LEGO ha mantenido a mis hijos entretenidos por horas, sino también porque ha sido una excelente actividad para fortalecer mis vínculos con ellos".

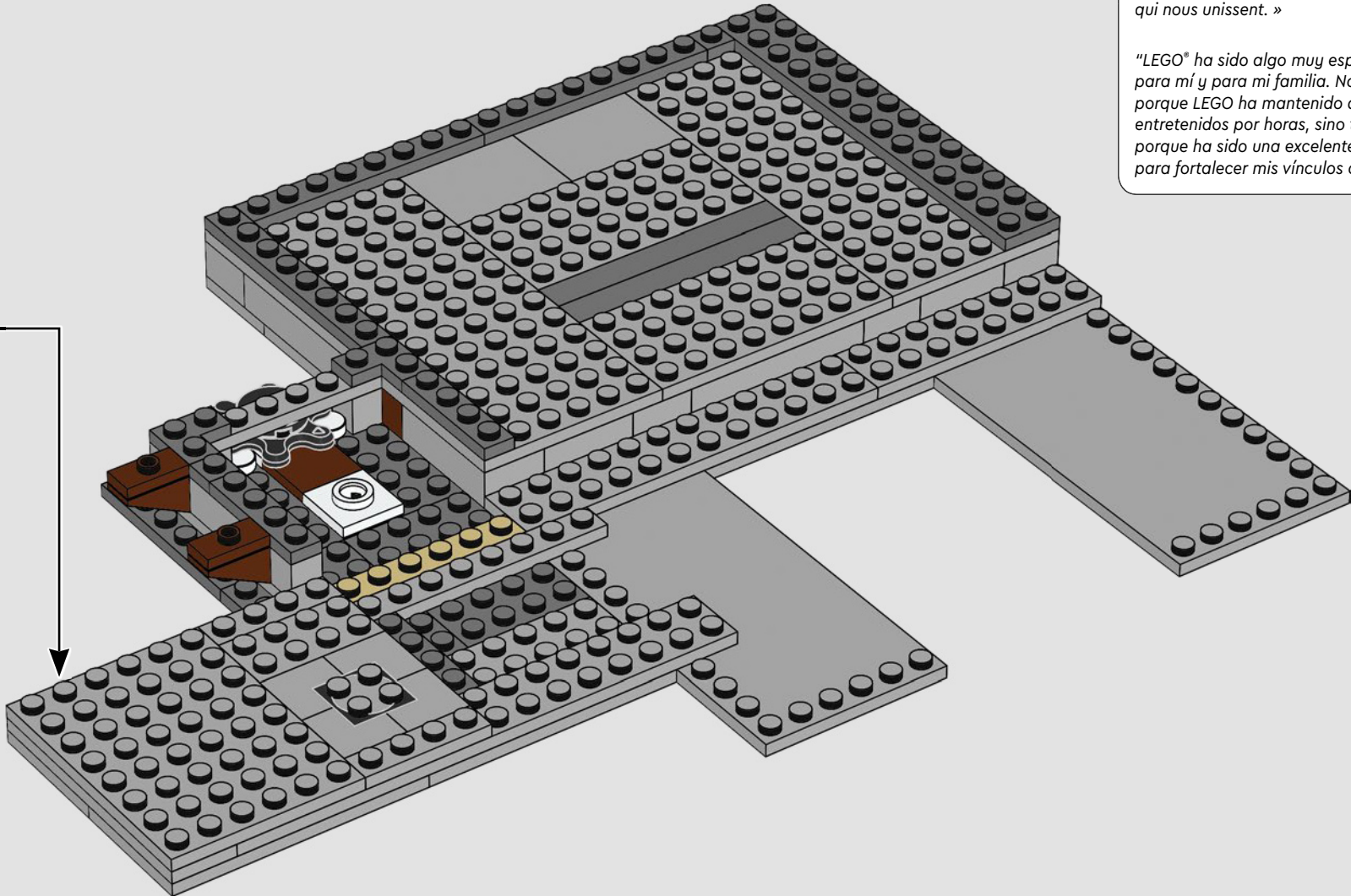

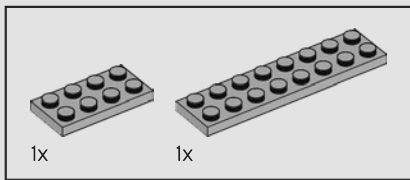

24

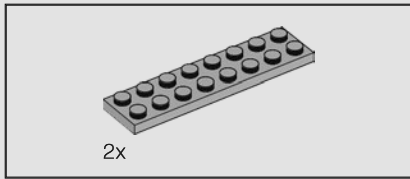
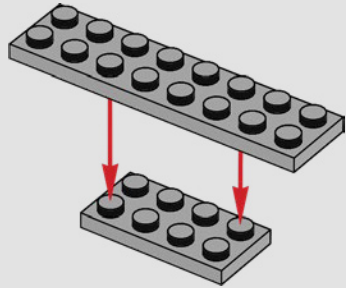

25

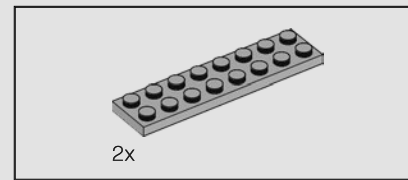
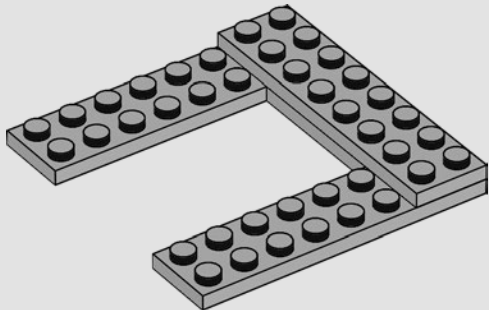

26

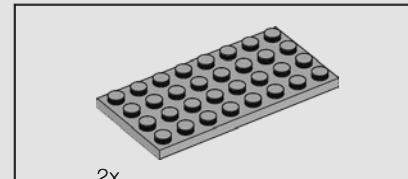
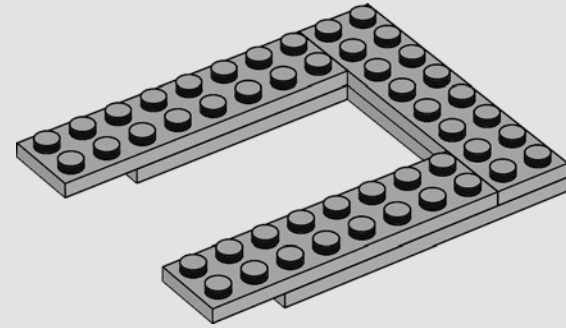

27

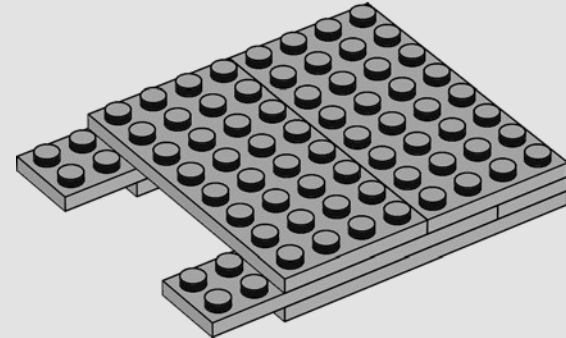

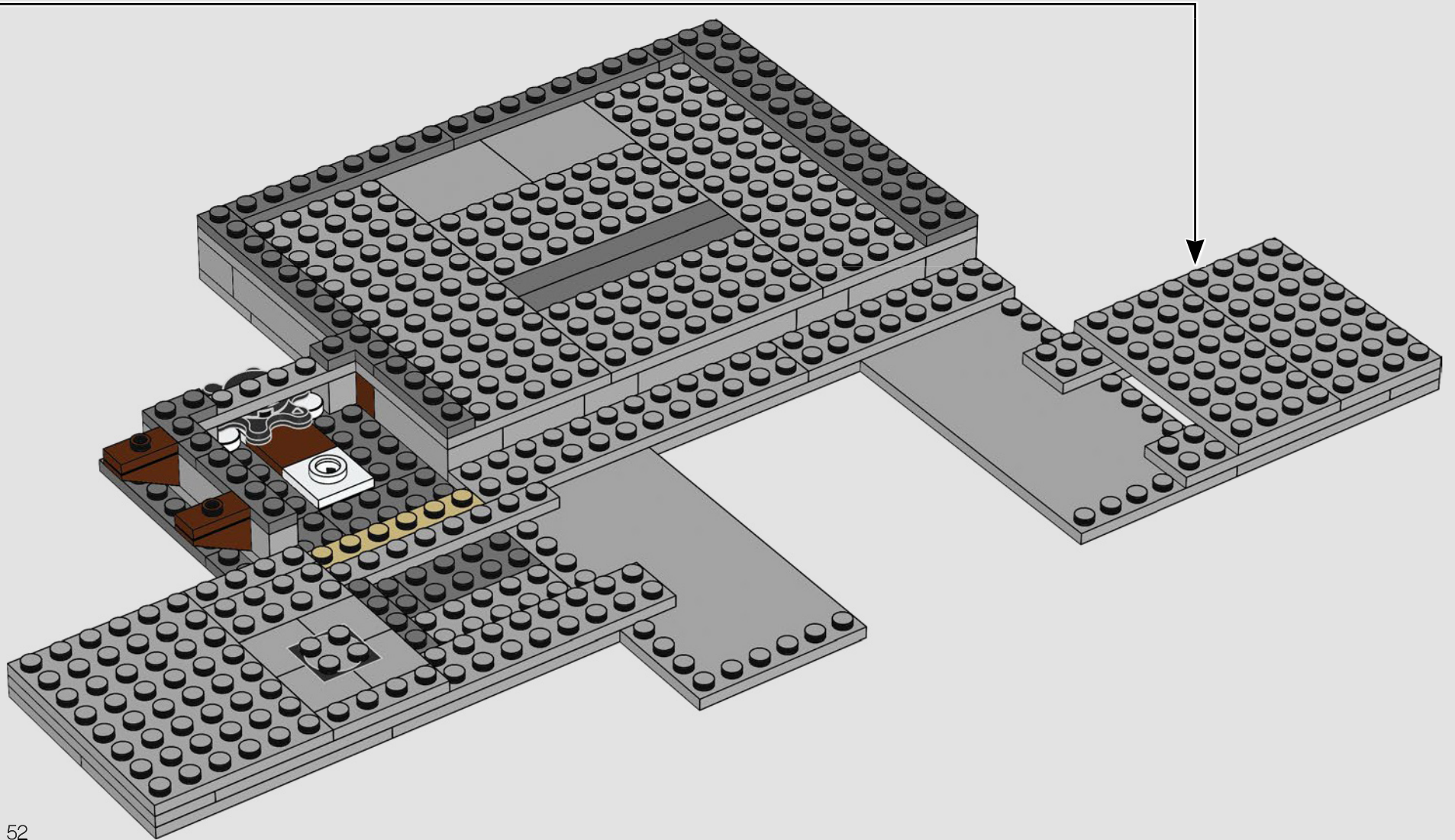

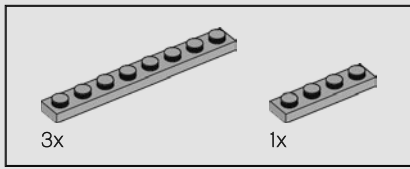

29

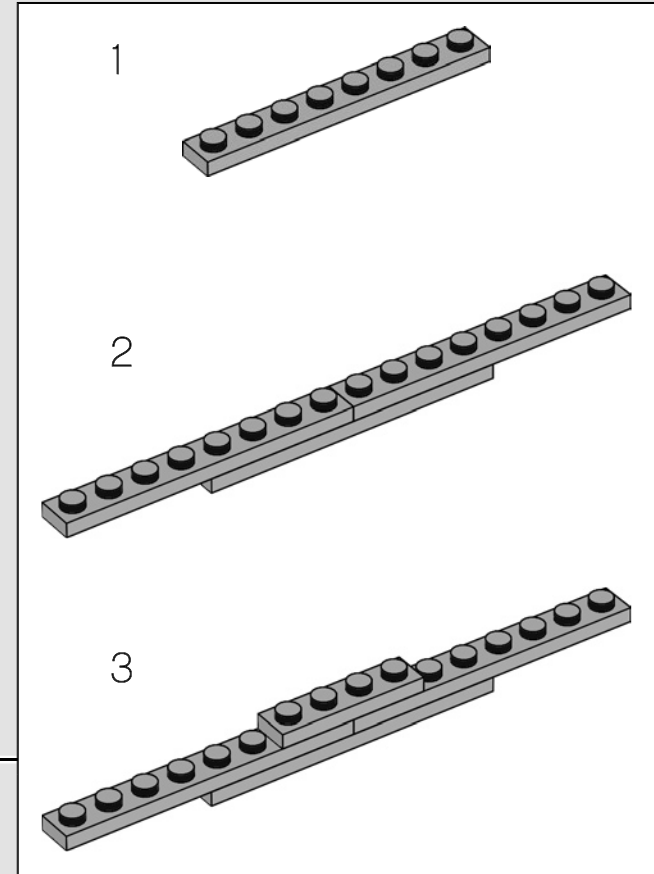
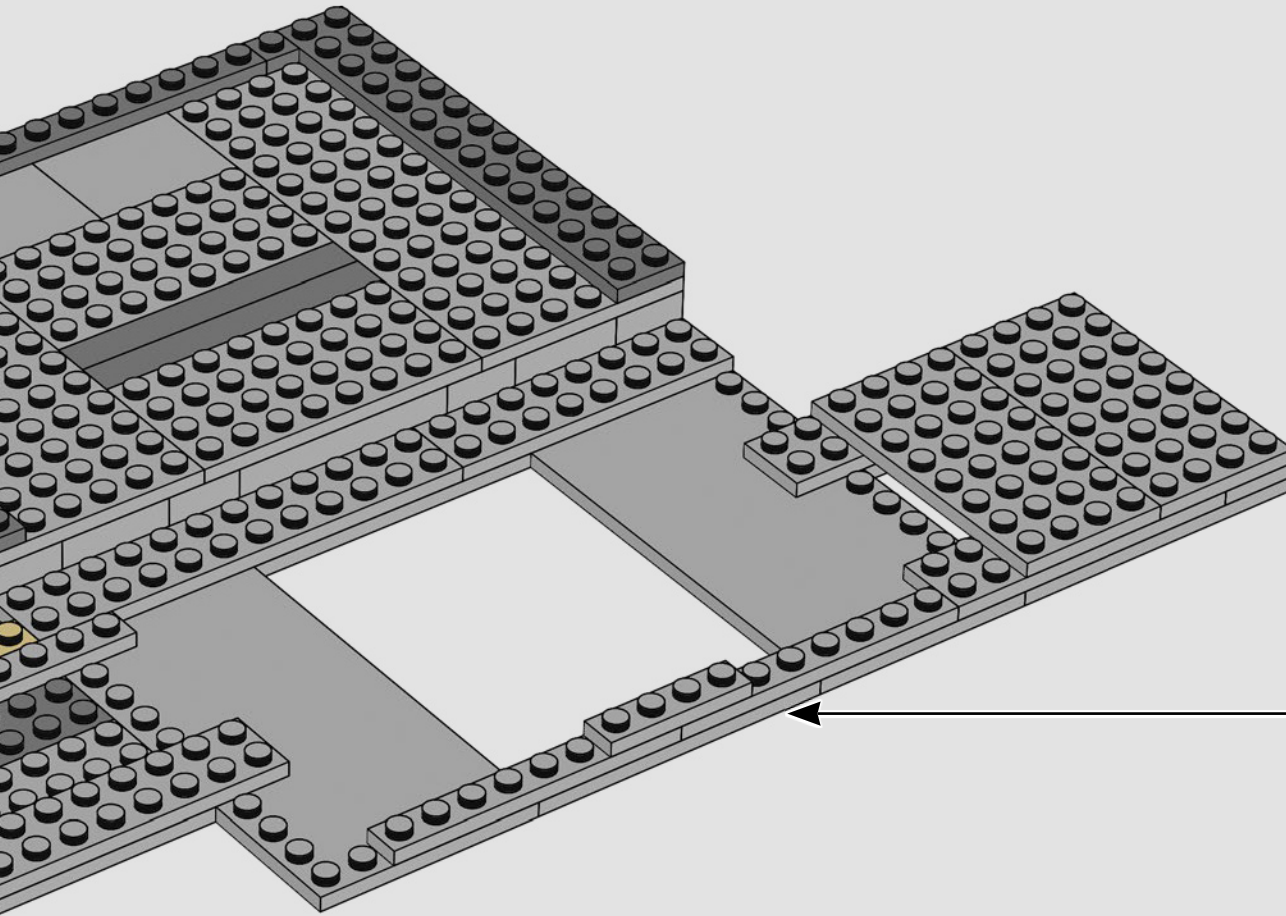

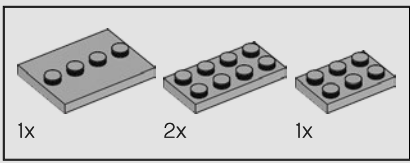

30

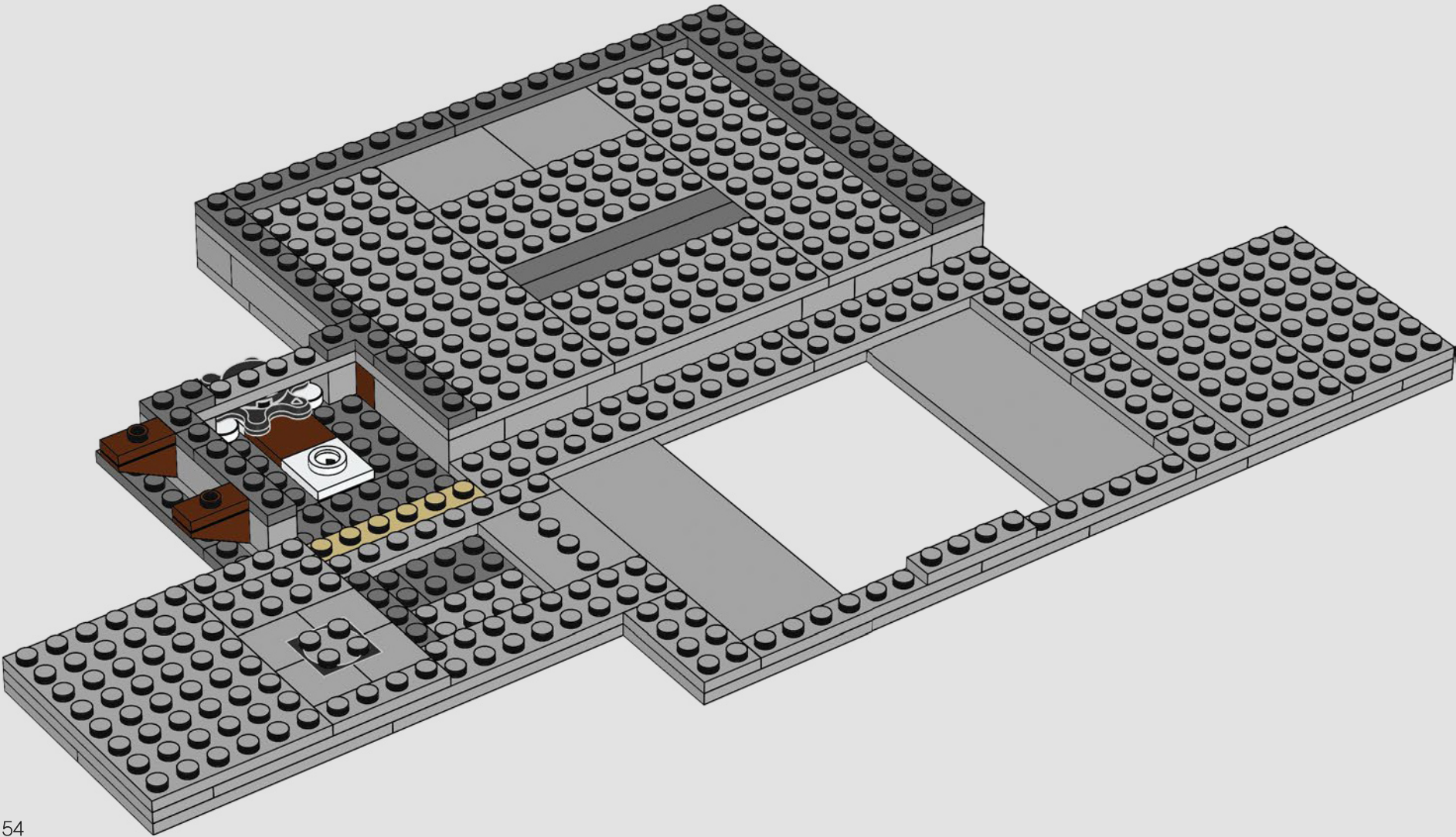

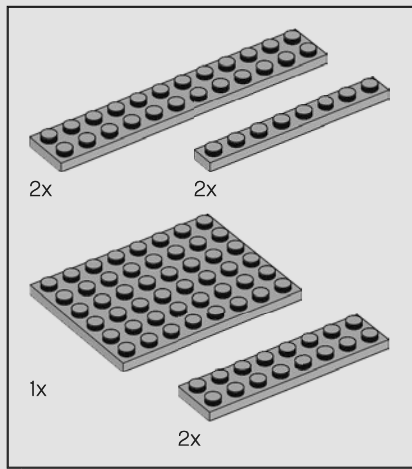

31

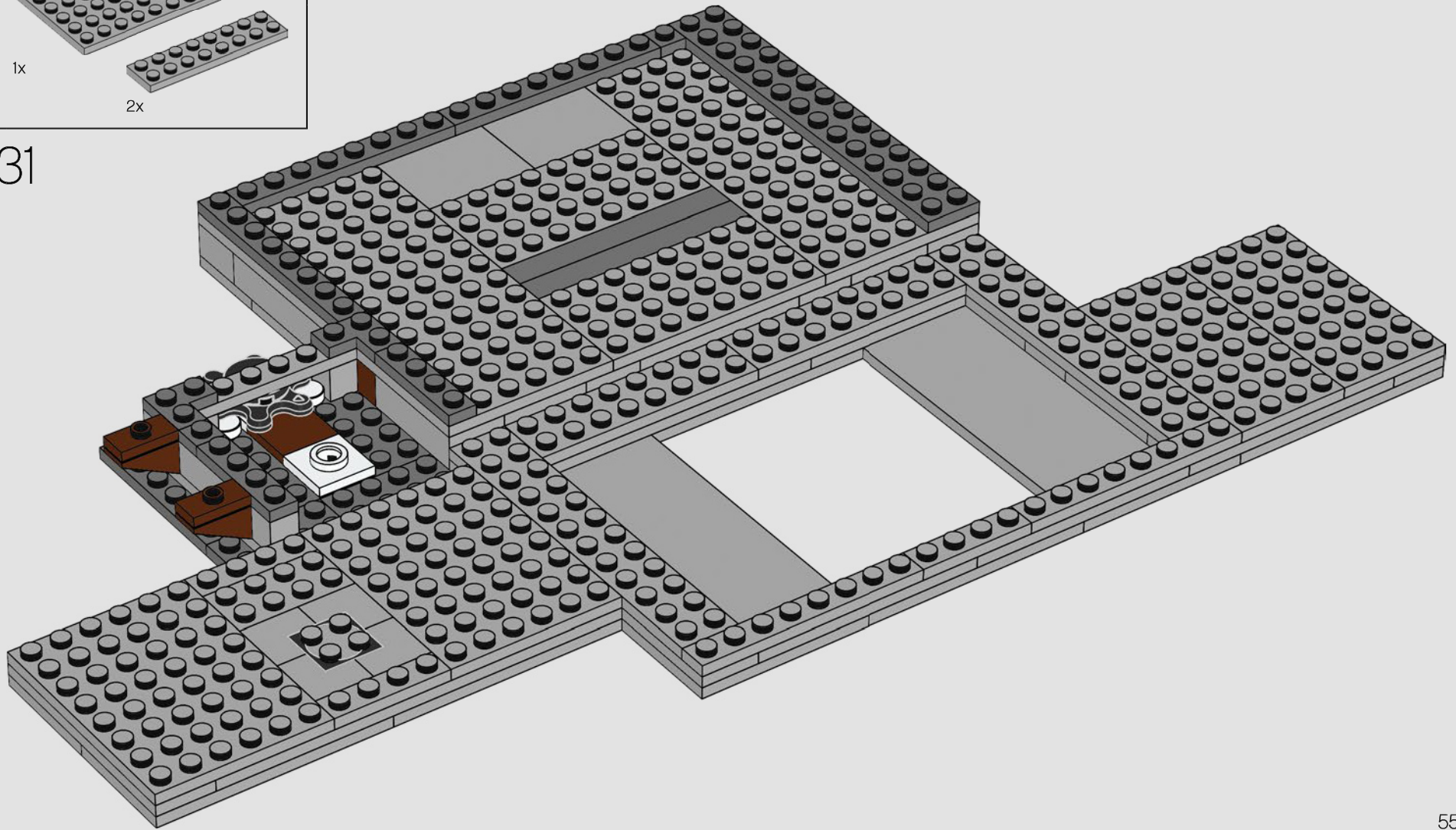

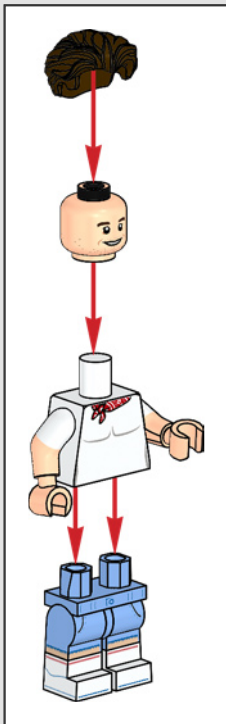
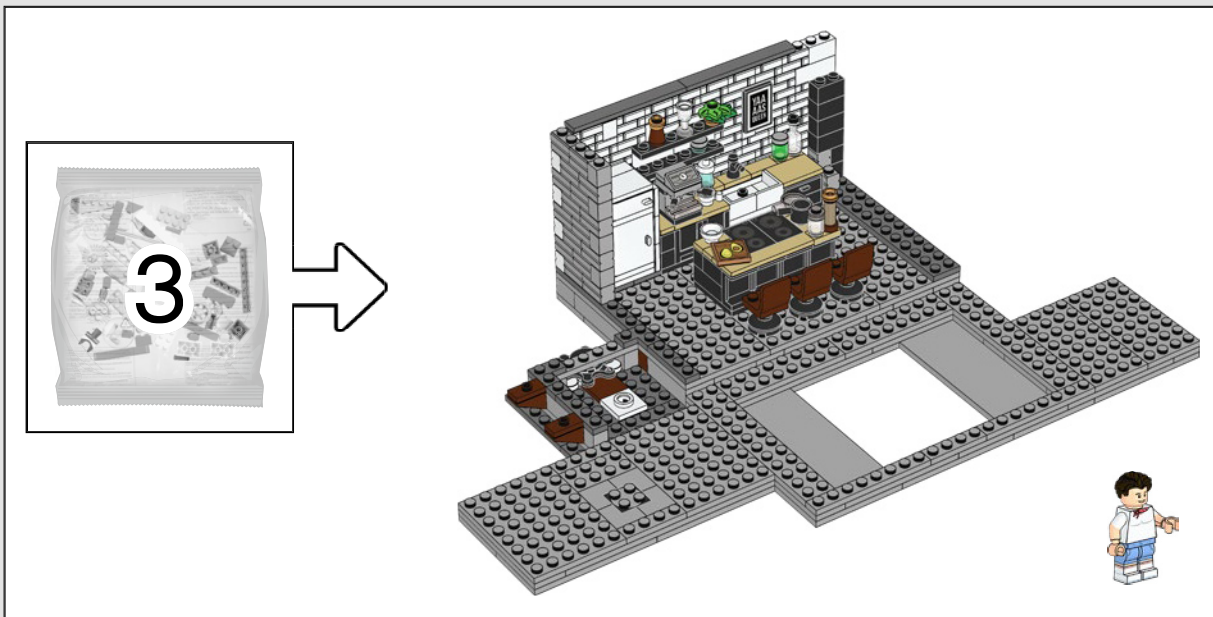

Antoni Porowski

"Loving that little neckerchief, and of course my LEGO® accessory had to be a tiny chopping board with avocados."

« J'adore le petit foulard, et bien entendu, mon accessoire LEGO® devait être une petite planche à découper avec des avocats. »

"Me encanta la pañoleta en miniatura y, por supuesto, mi accesorio LEGO® no podía ser otra cosa que una pequeña tabla de picar con aguacates".



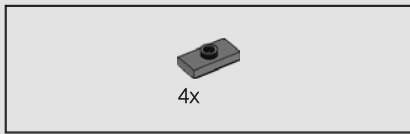

32

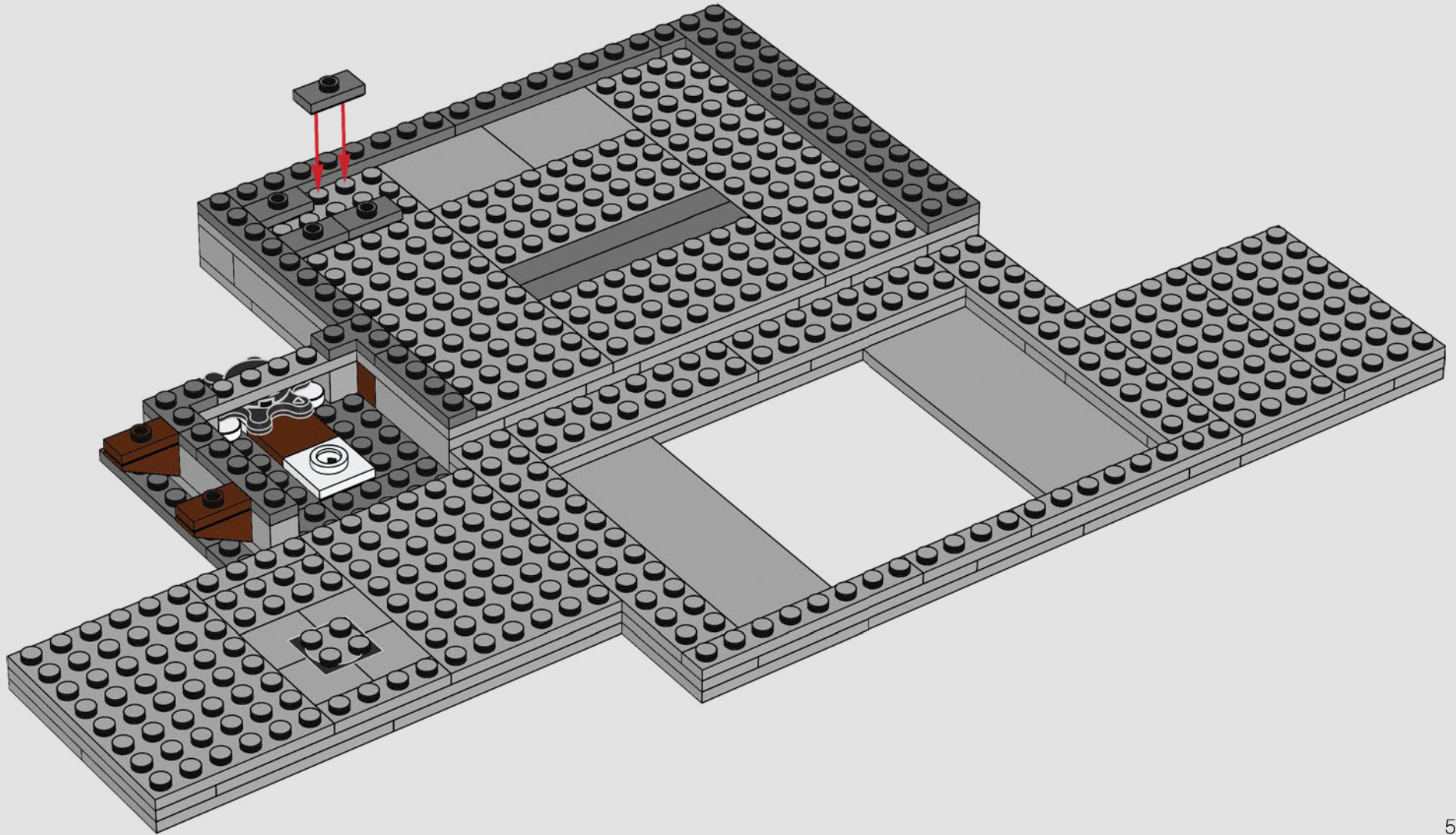

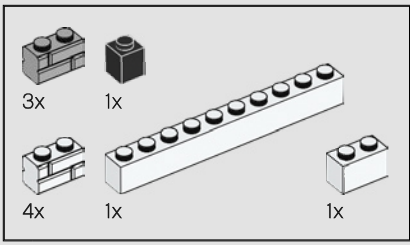

33



Bobby Berk

"As a child, LEGO® ignited the creative flame inside me and made me feel like the possibilities in life were just as endless as the things I was able to build."

« Quand j'étais enfant, LEGO® a allumé la flamme créatrice en moi et m'a donné le sentiment que mes possibilités étaient tout aussi infinies que les choses que je pouvais construire. »

"Cuando era niño, LEGO® encendió la llama creativa dentro de mí y me hacía sentir que las posibilidades en la vida eran tan ilimitadas como las cosas que podía construir".

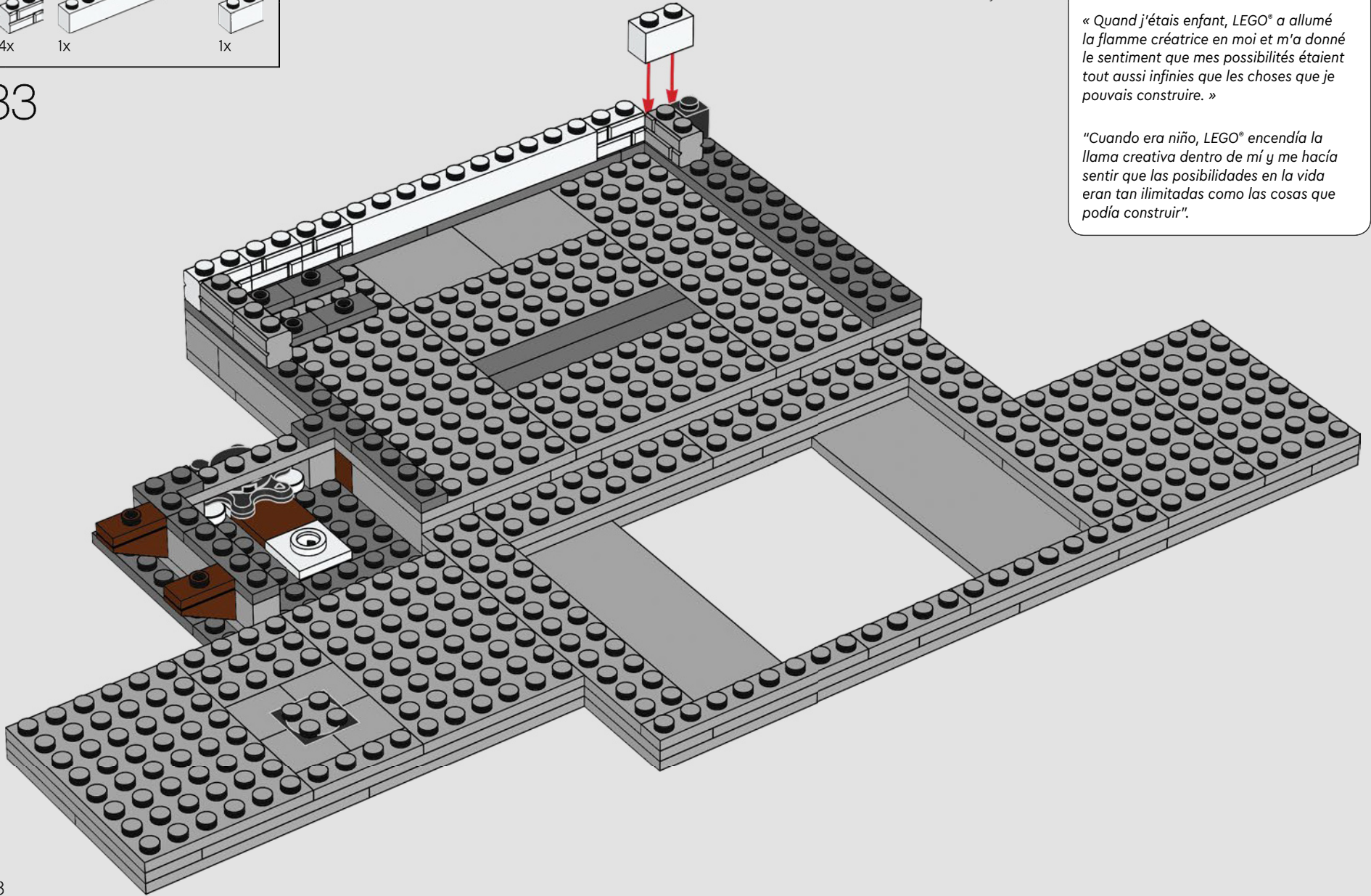

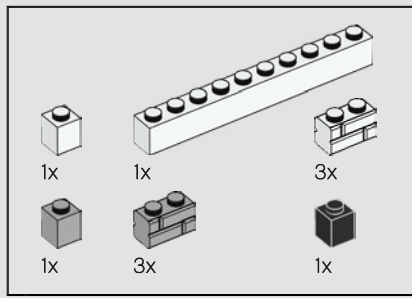

34

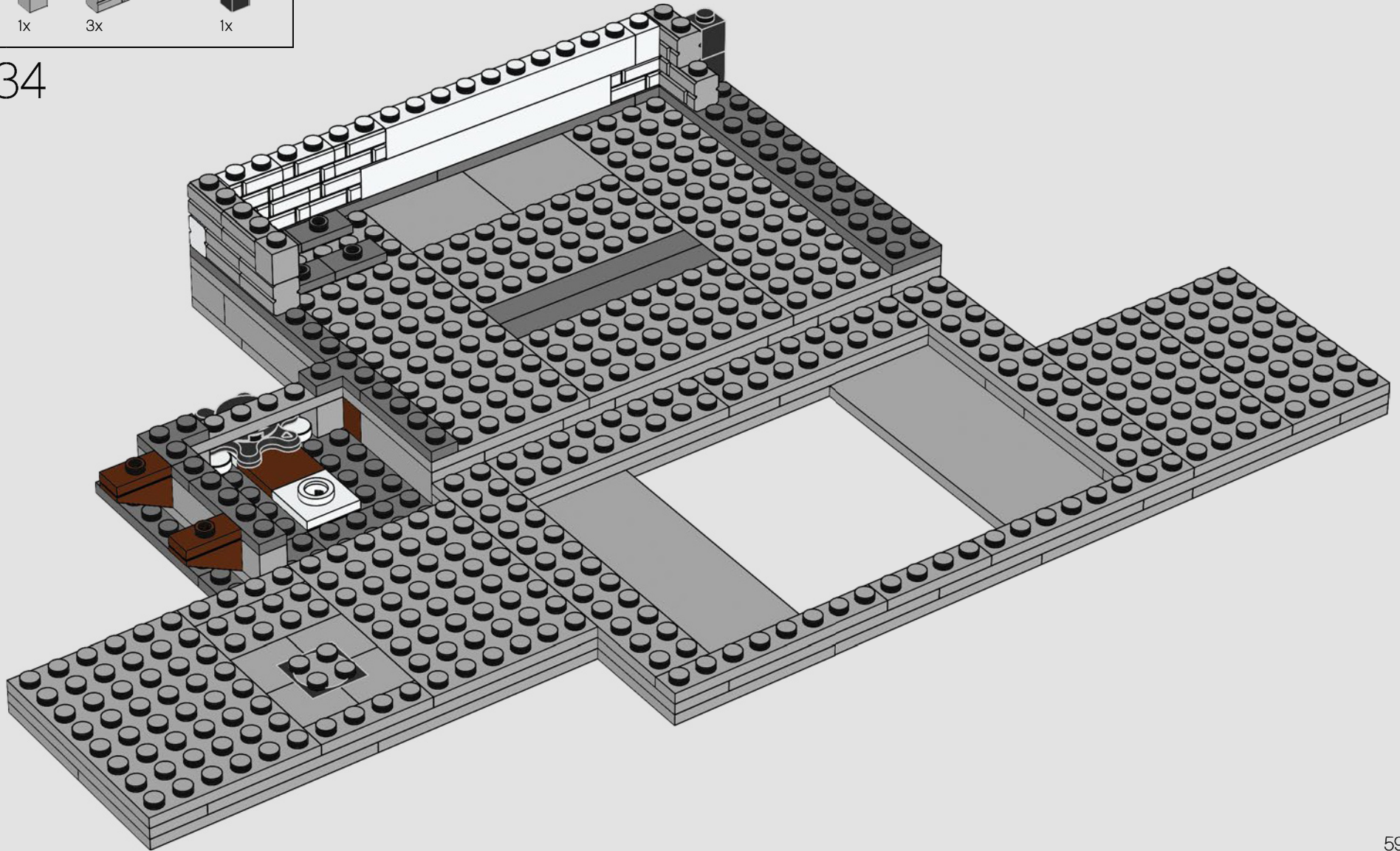

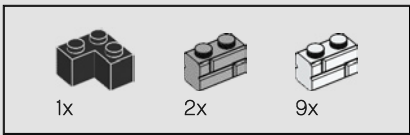

35

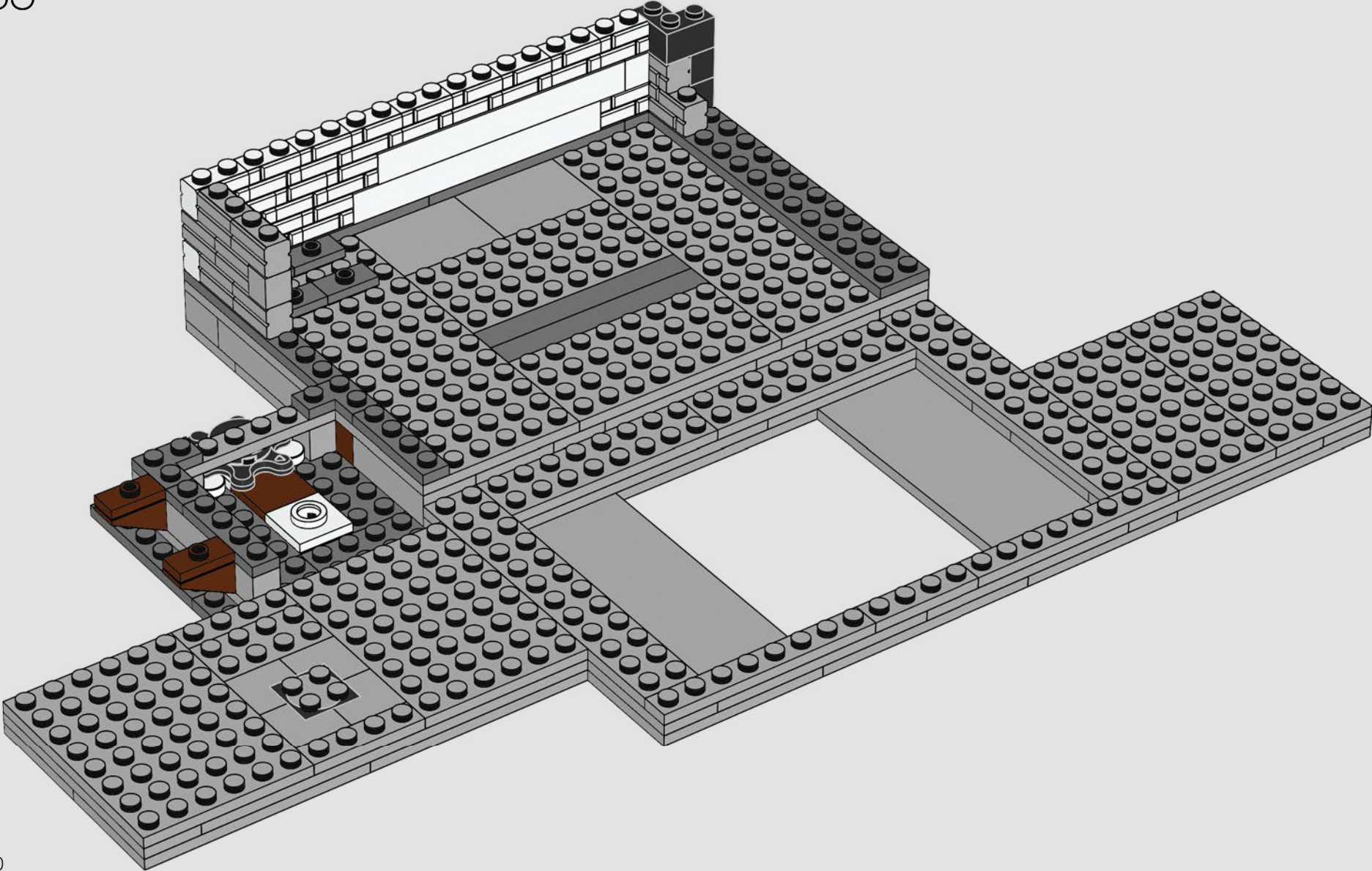

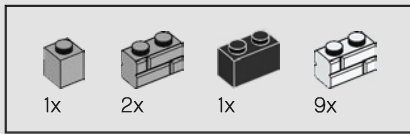

36

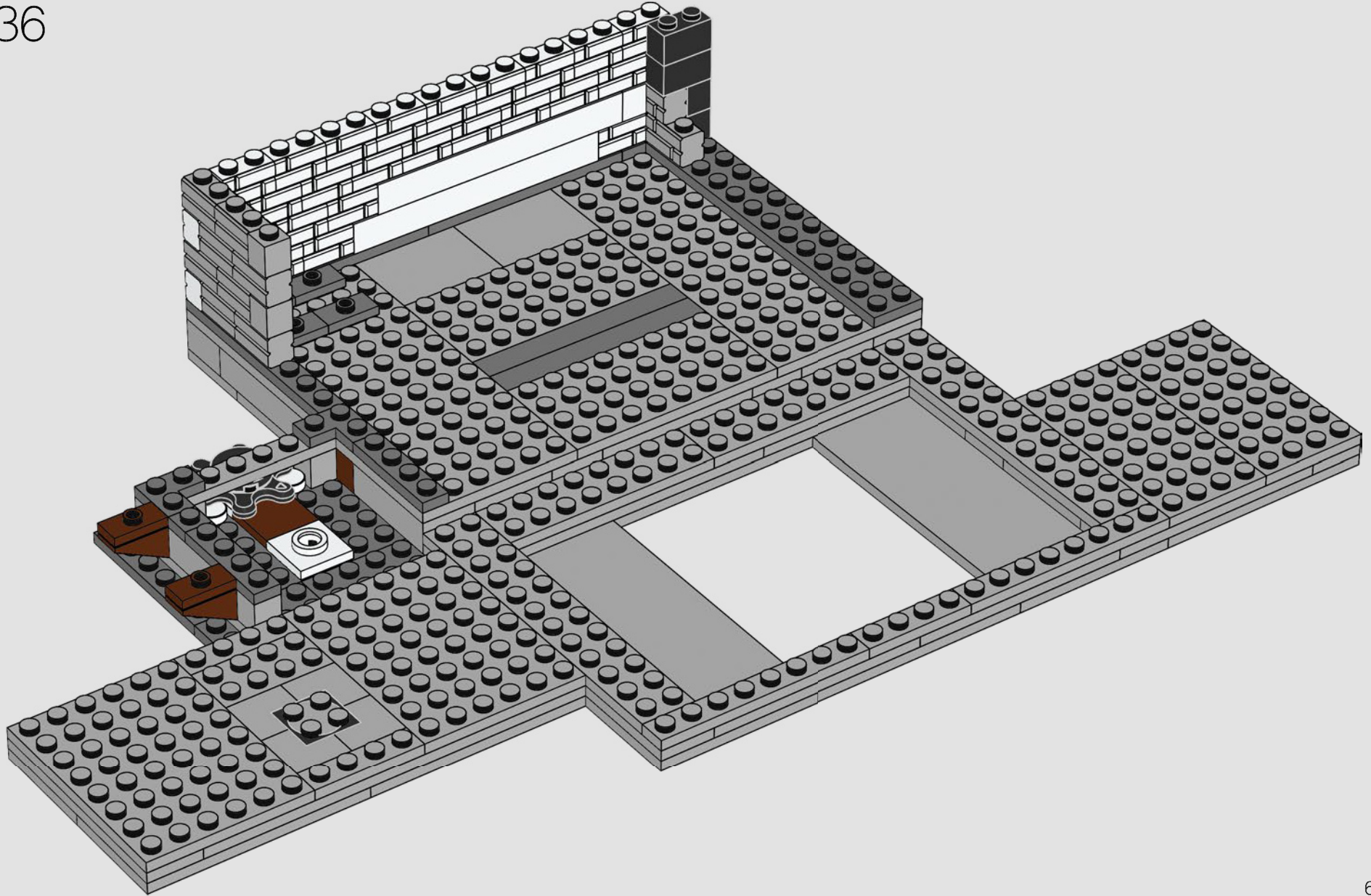

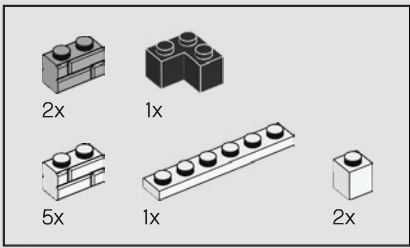

37

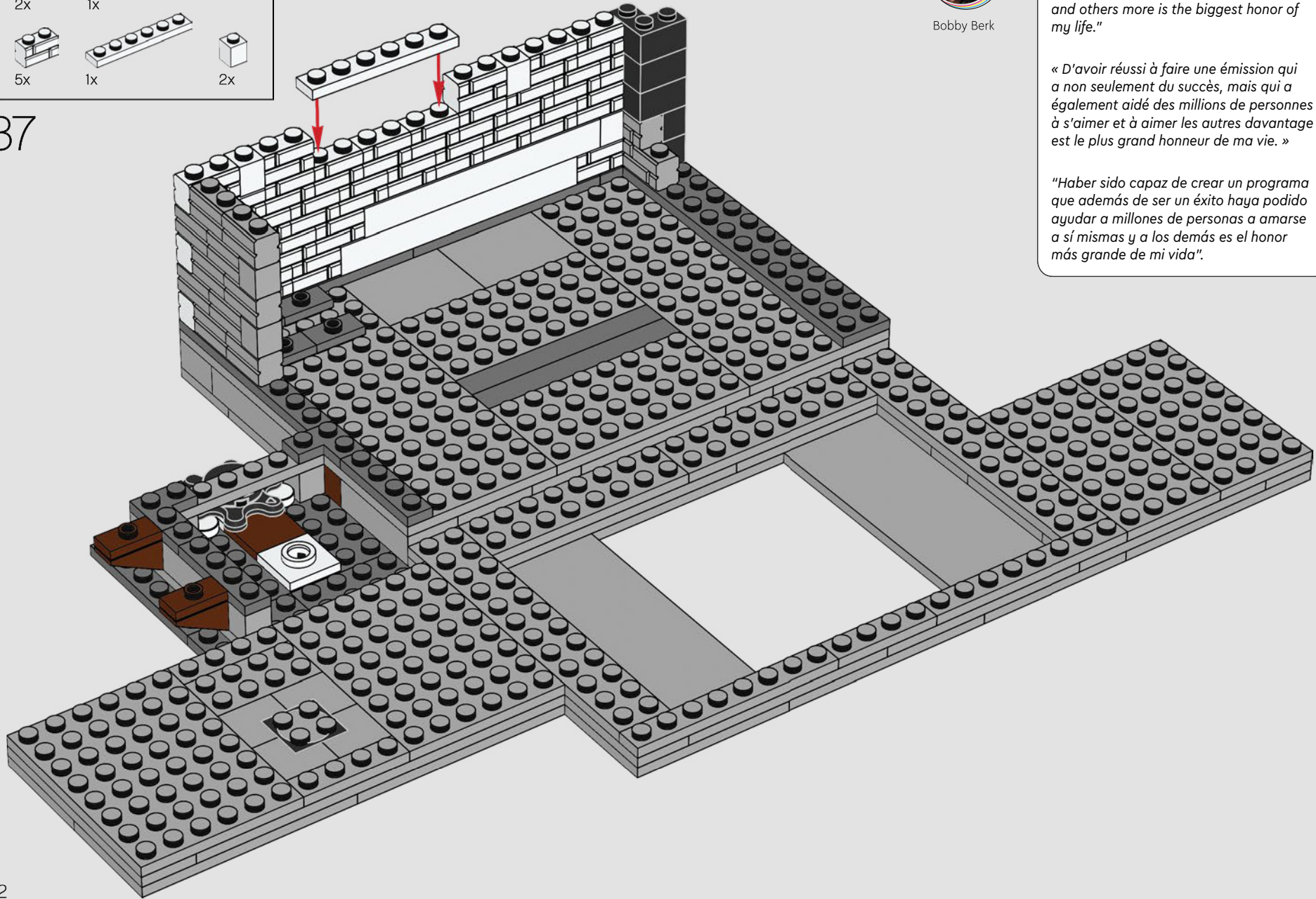

Bobby Berk

*"To be able to make a show that has not only been a success but is also able to help millions of people to love themselves and others more is the biggest honor of my life."*

*« D'avoir réussi à faire une émission qui a non seulement du succès, mais qui a également aidé des millions de personnes à s'aimer et à aimer les autres davantage est le plus grand honneur de ma vie. »*

*"Haber sido capaz de crear un programa que además de ser un éxito haya podido ayudar a millones de personas a amarse a sí mismas y a los demás es el honor más grande de mi vida".*

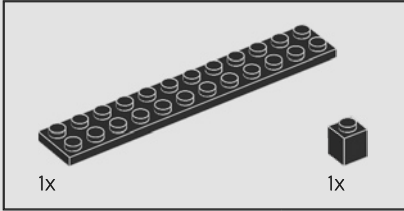
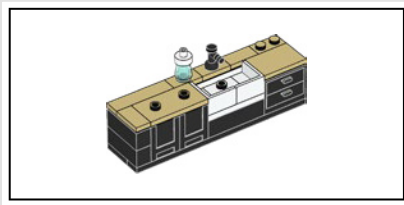

38

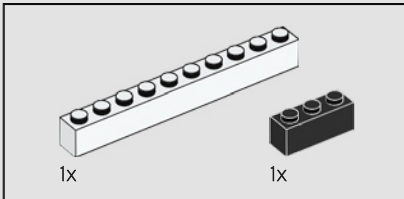
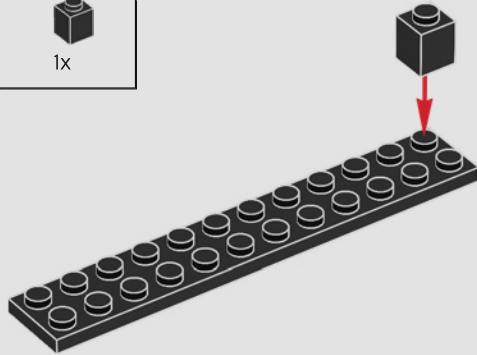

39

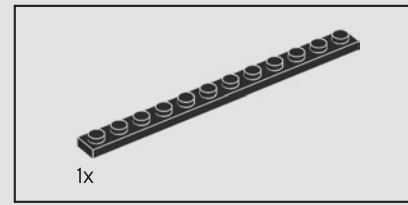
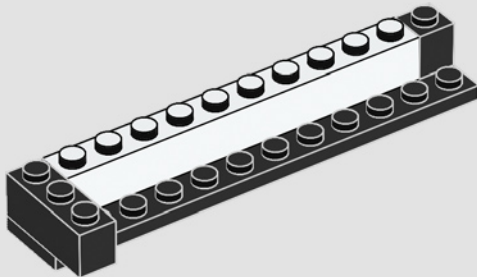

40

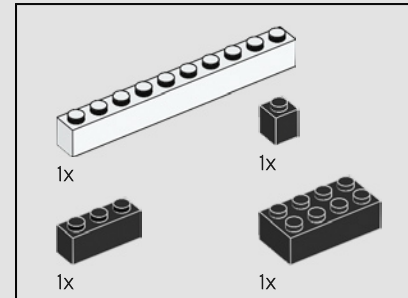
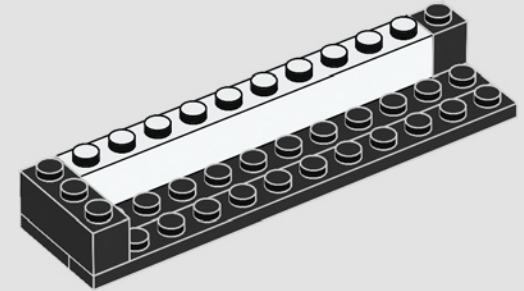

41

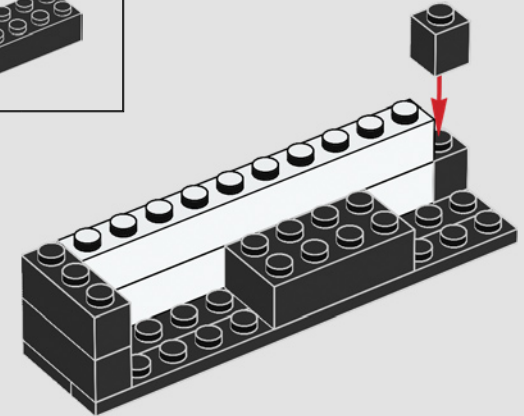



42

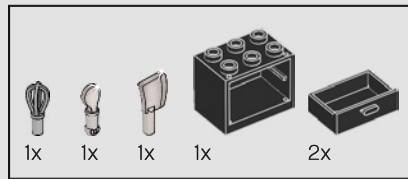
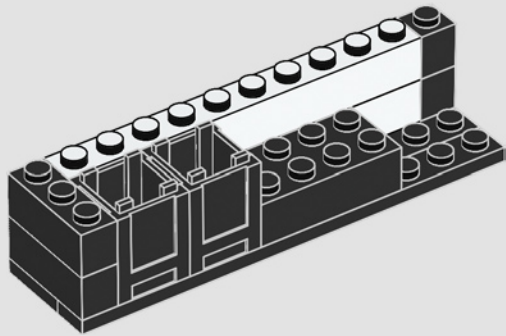

43

1

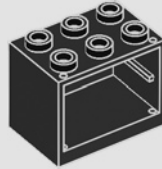

2

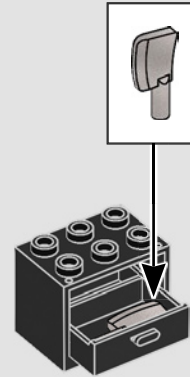

3

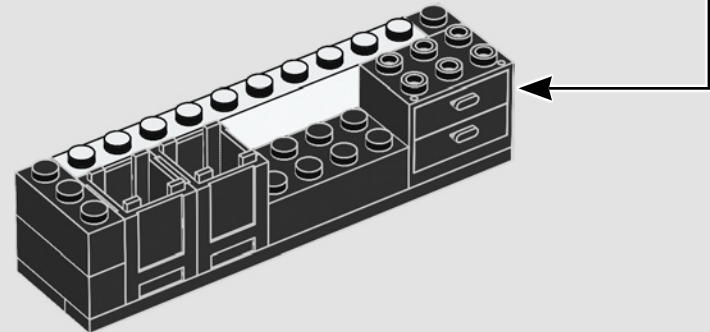
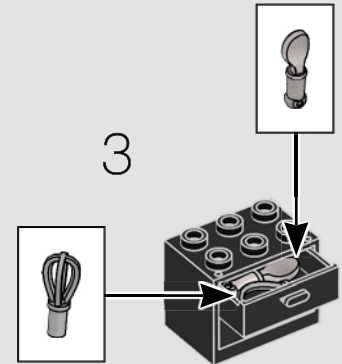



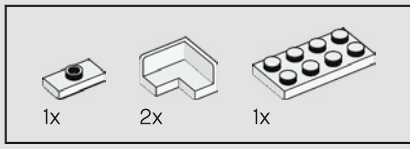

44

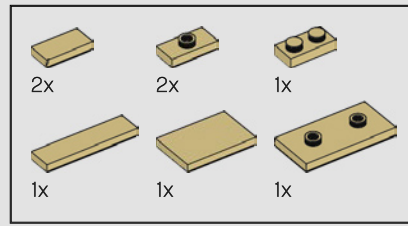
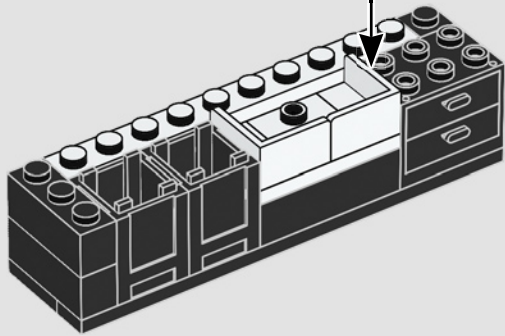
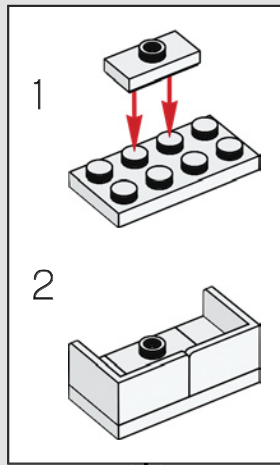

45

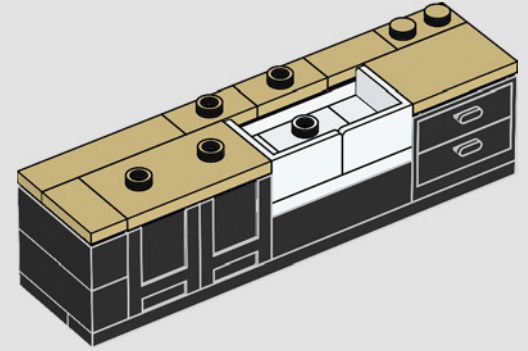

46

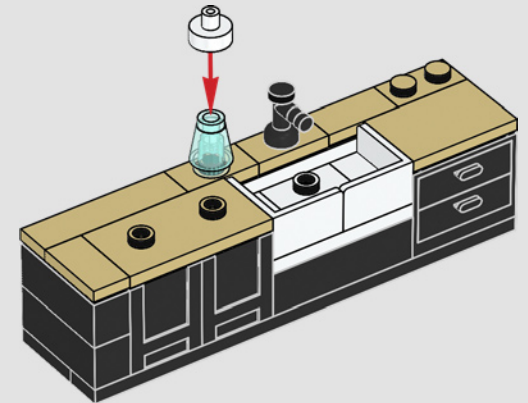

47

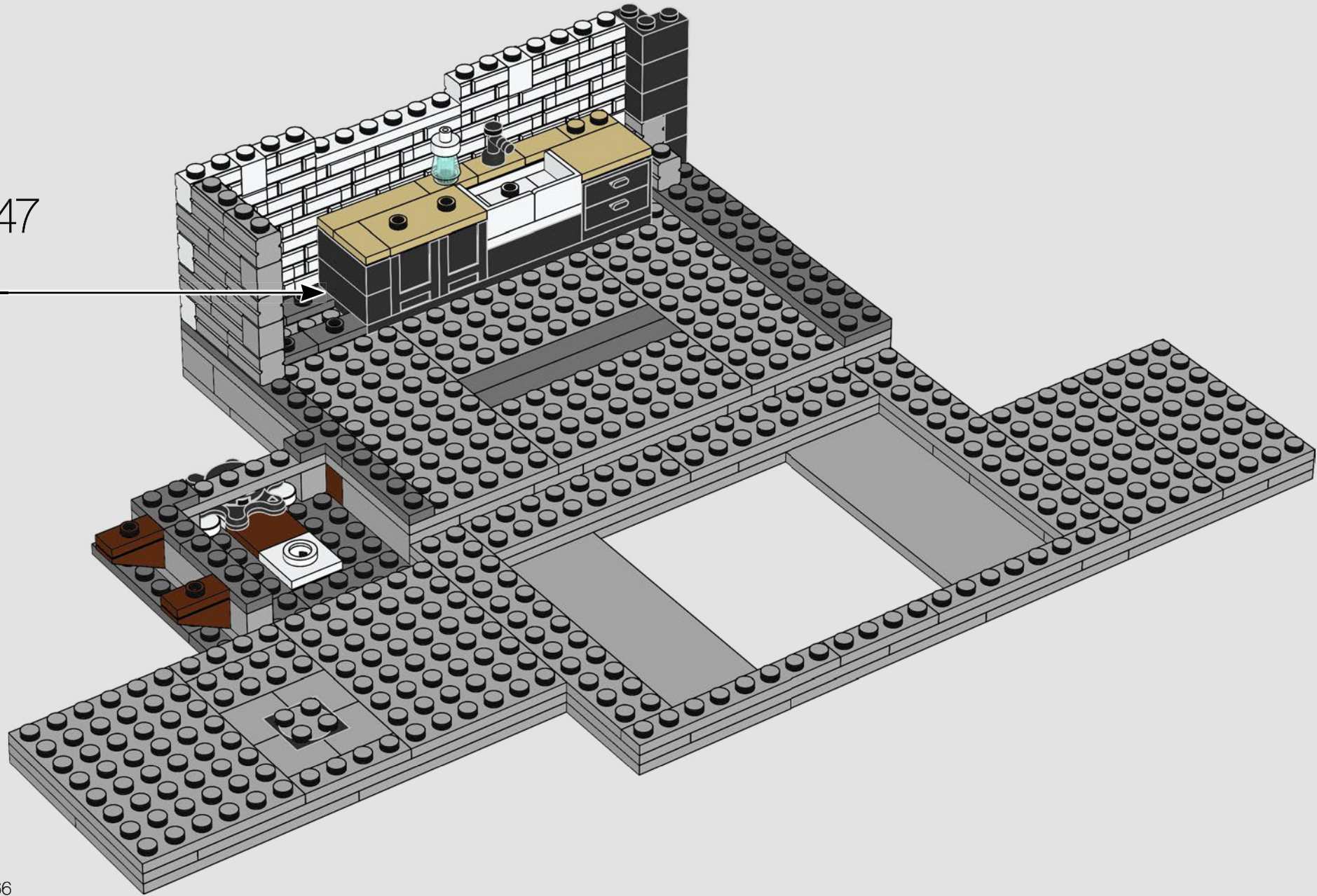

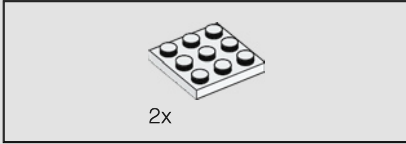
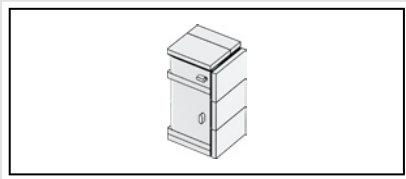

48

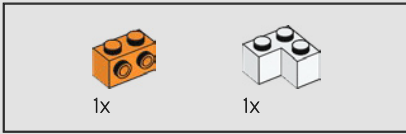
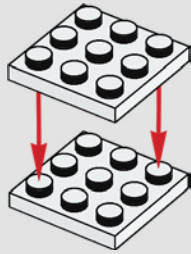

49

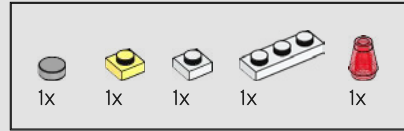
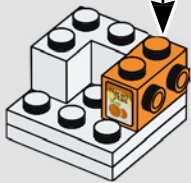
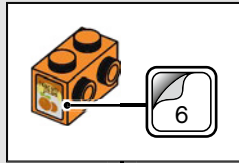

50

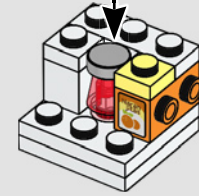
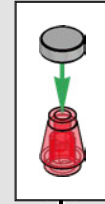

51

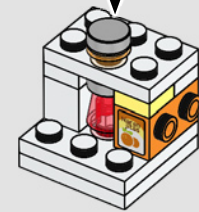
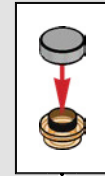

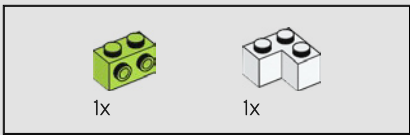

52

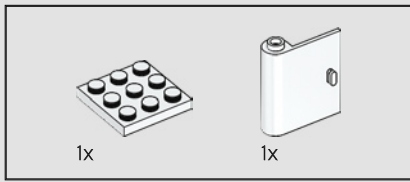
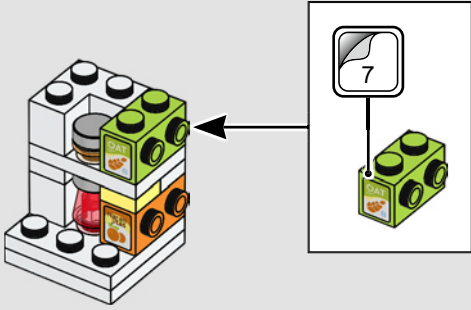

54

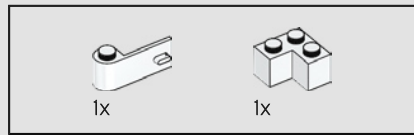
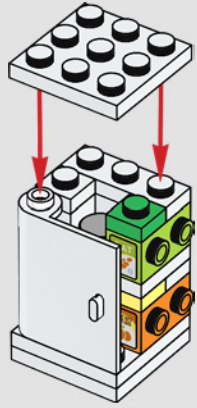

56

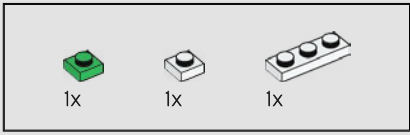

53



55

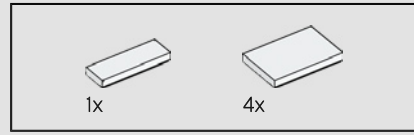
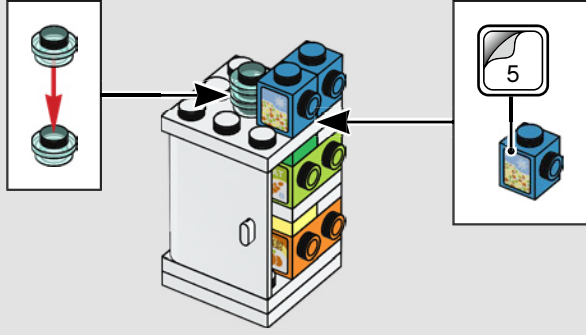

57



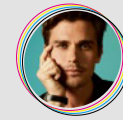

Antoni Porowski

*"Building with LEGO® is in some ways very much like cooking a meal. Of course, you can follow the recipe to make the perfect 'tried and tested' end result, or you can get all experimental and come up with your own creation."*

*« Construire avec LEGO®, c'est un peu comme préparer un repas. Bien sûr, vous pouvez suivre la recette pour obtenir le résultat parfaitement testé, ou vous pouvez tenter des expériences et arriver à une création entièrement de votre cru. »*

*"Construir con LEGO® es, de muchas maneras, como cocinar un platillo. Siempre puedes seguir la receta al pie de la letra y obtener un resultado perfecto que ha pasado todas las pruebas, o puedes elegir experimentar y crear algo totalmente nuevo de tu autoría".*



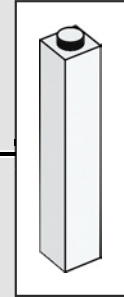
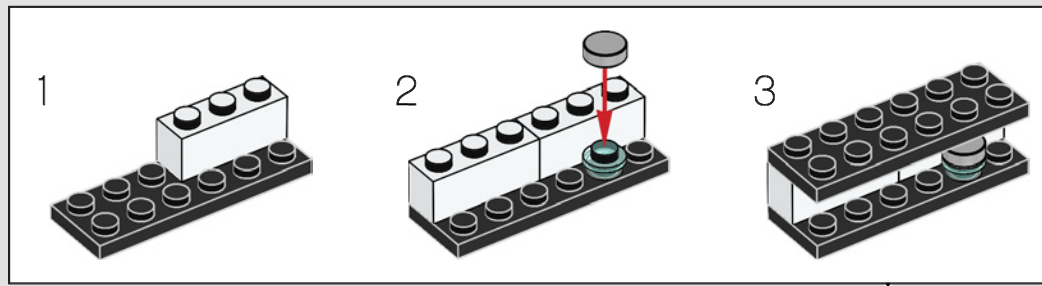
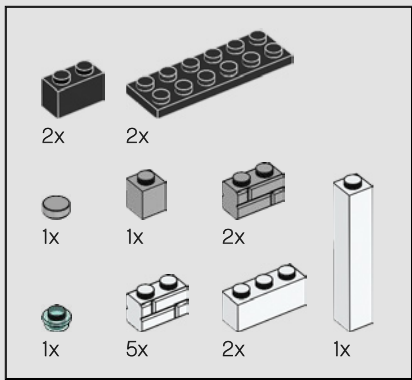

59

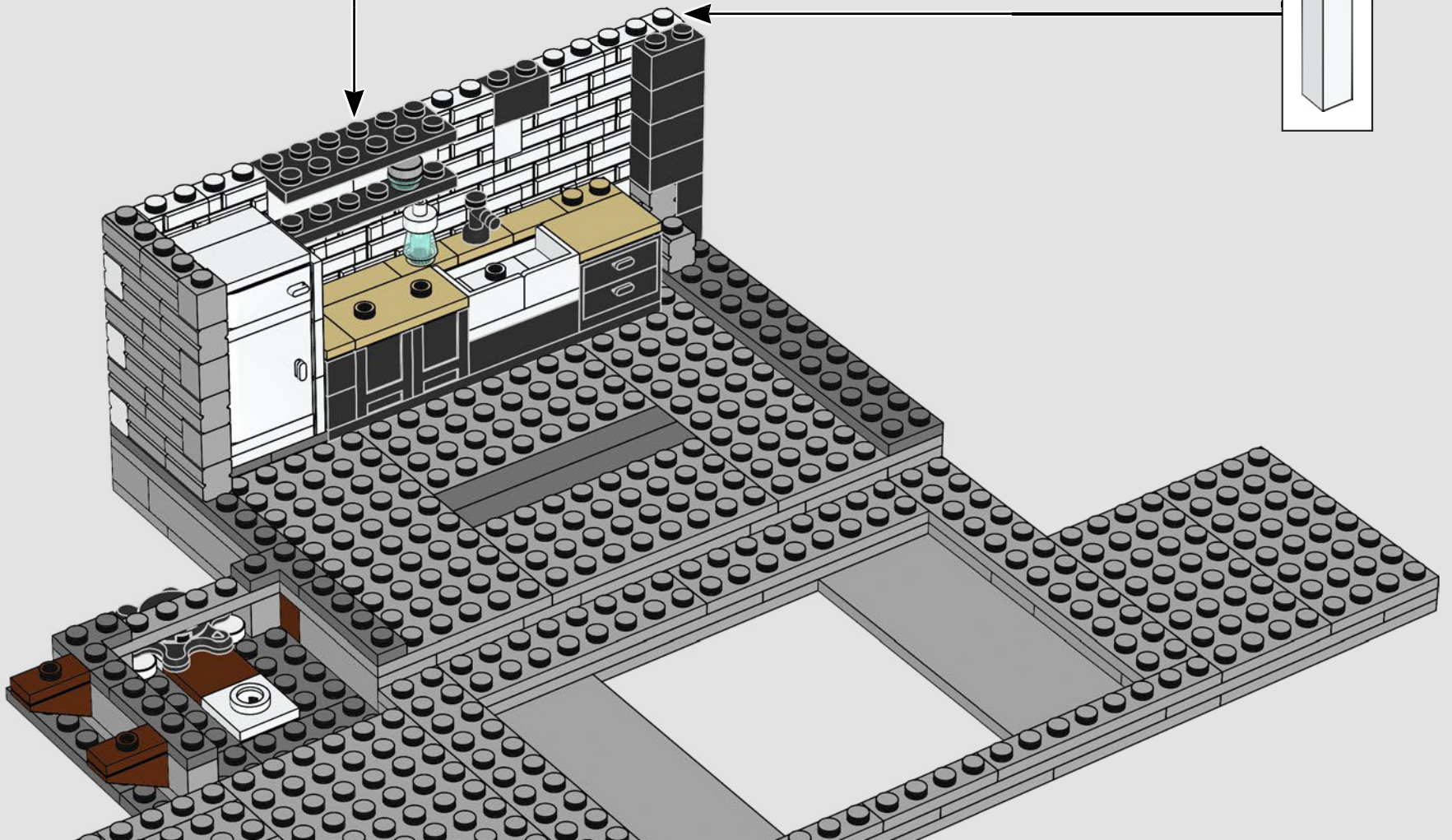

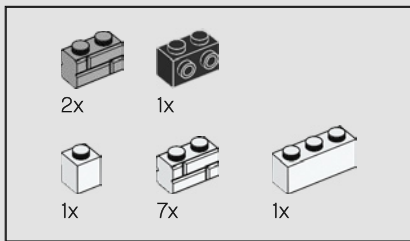

60

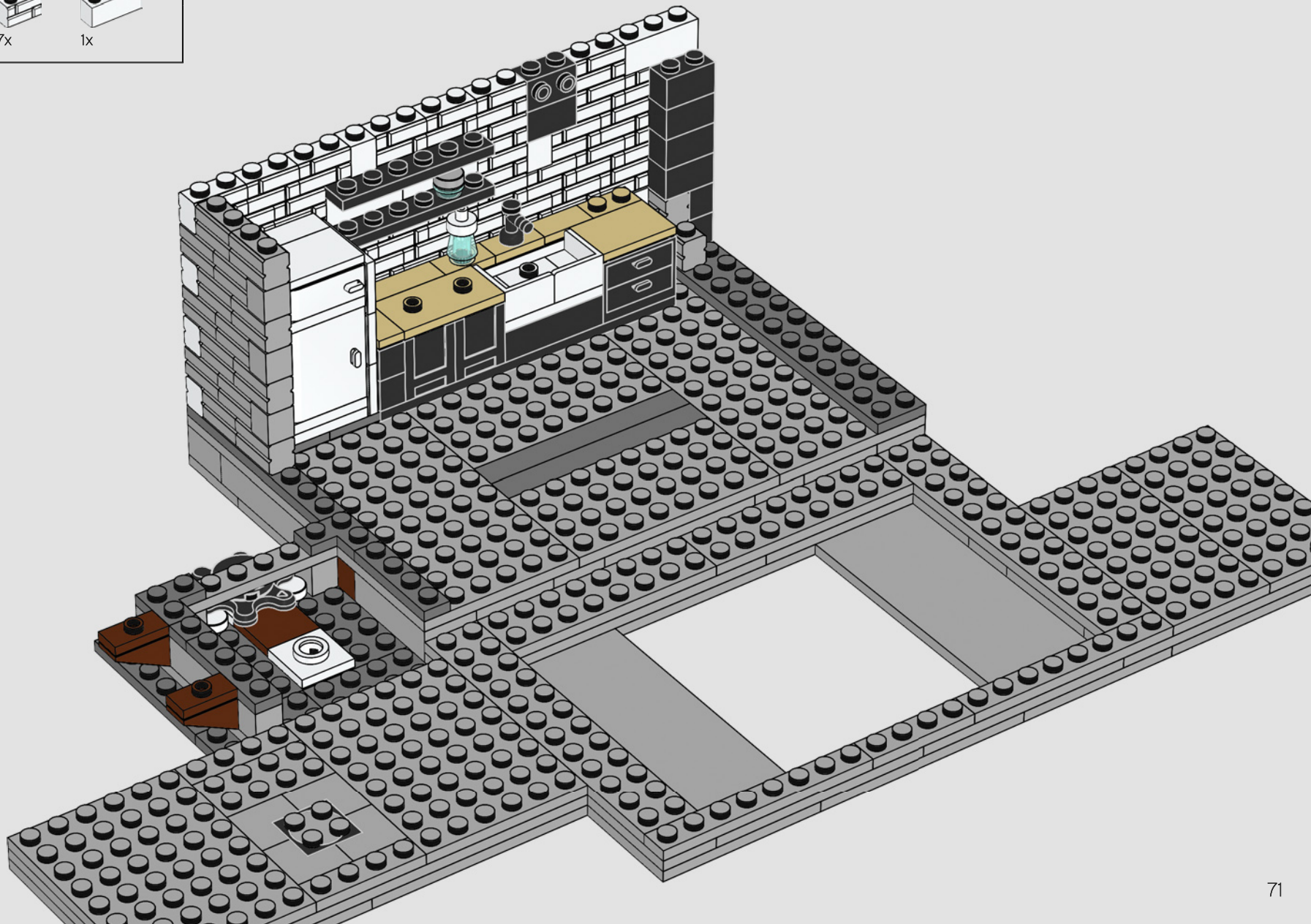

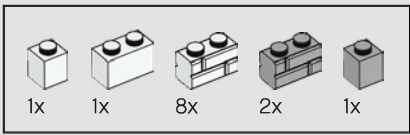

61



Bobby Berk

*"On Queer Eye we're all about fresh starts, re-building, and making the best of what you've got - and what better toy is there to celebrate that than LEGO?"*

*« La philosophie de Queer Eye, c'est de prendre un nouveau départ, de reconstruire, et de tirer le meilleur parti de nous-mêmes - et quel meilleur jouet pour célébrer tout ça que LEGO ? »*

*"En Queer Eye, todo se trata de nuevos comienzos, de reconstrucción y de hacer lo mejor con lo que tienes. ¿Con qué otro juguete podrían celebrarse tales cosas mejor que con LEGO?"*





62

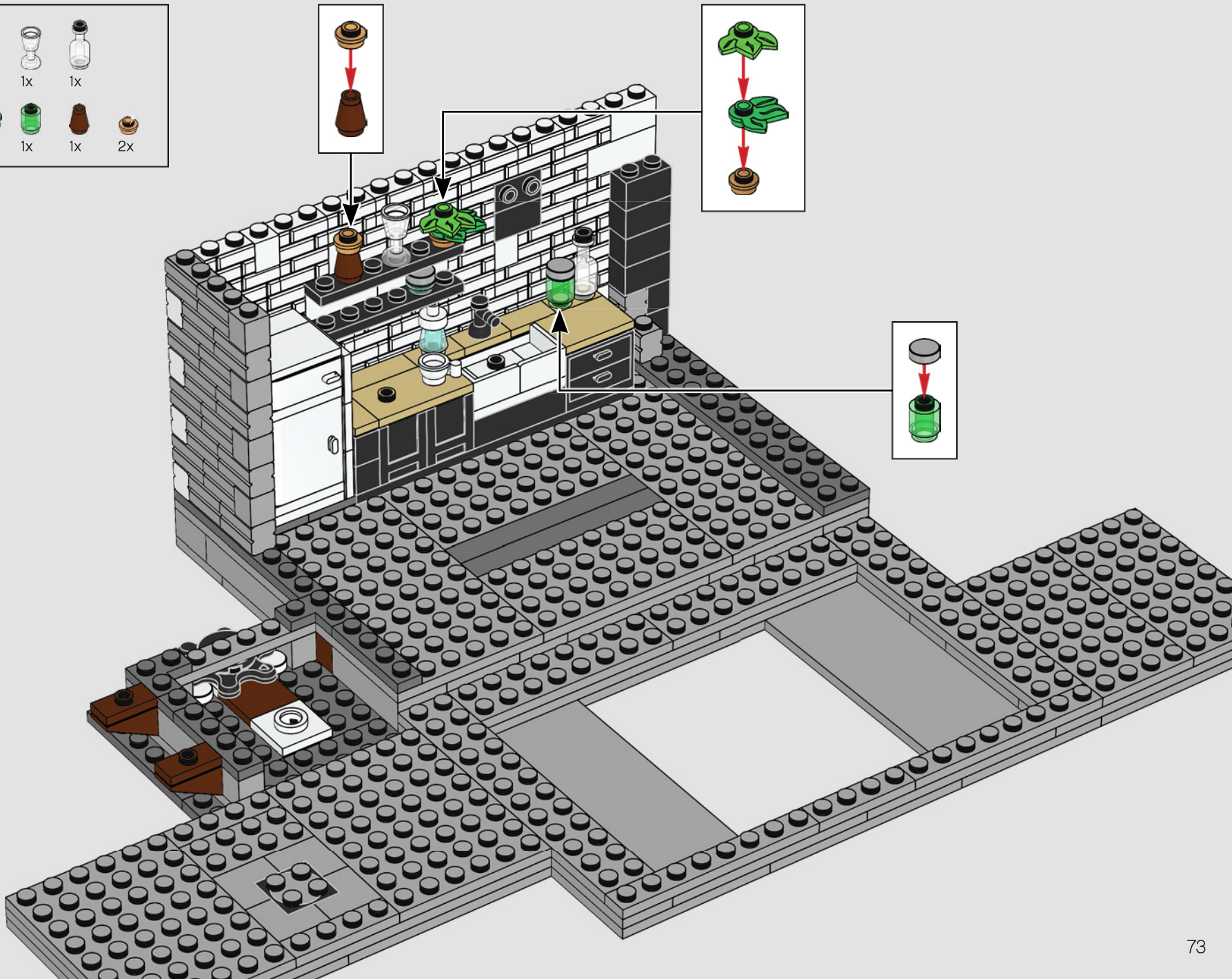

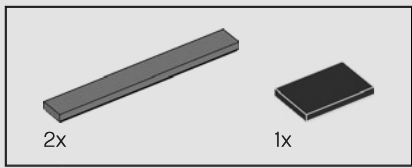

63

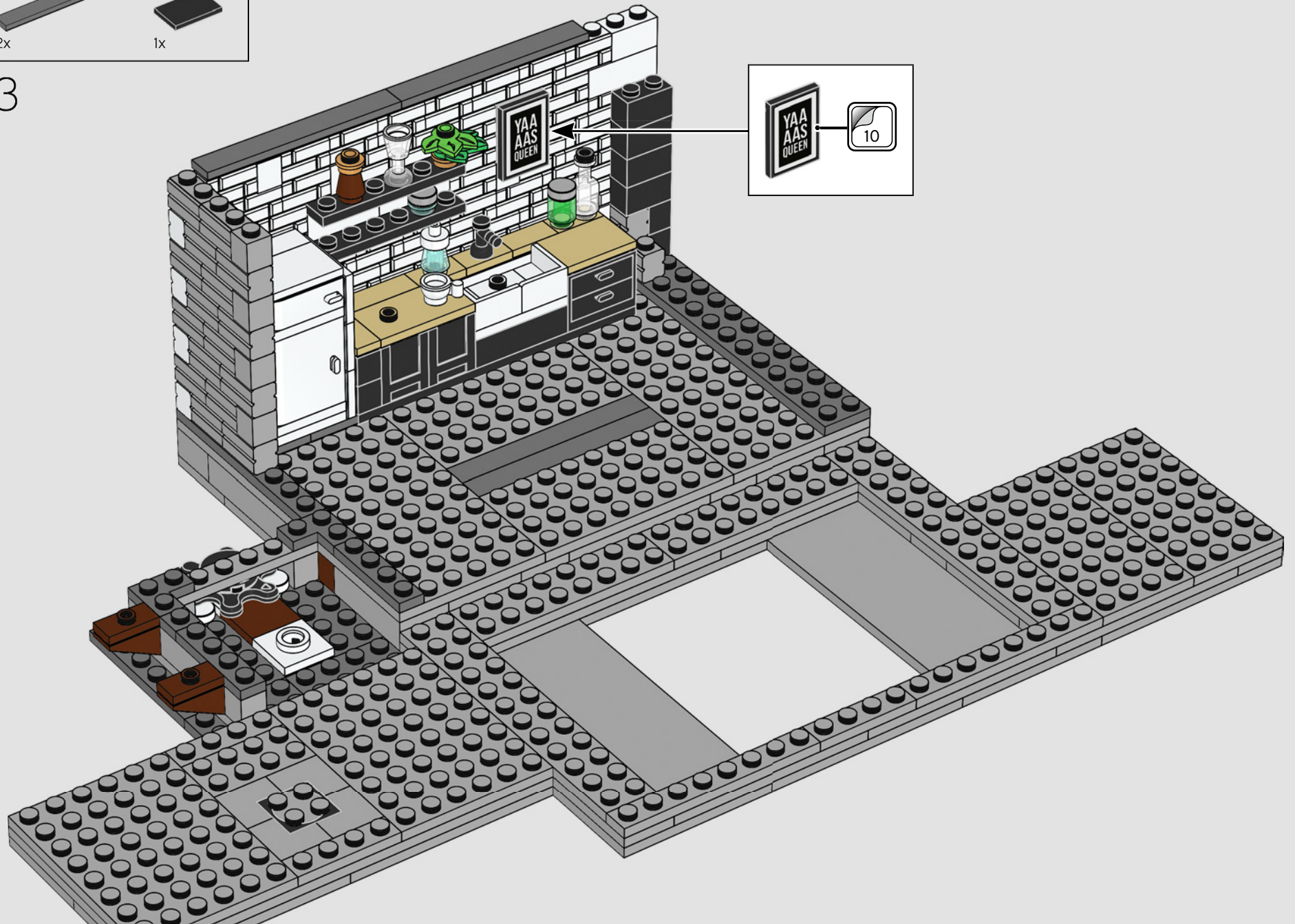

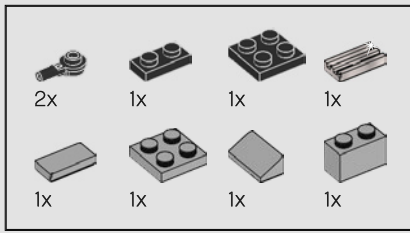

64

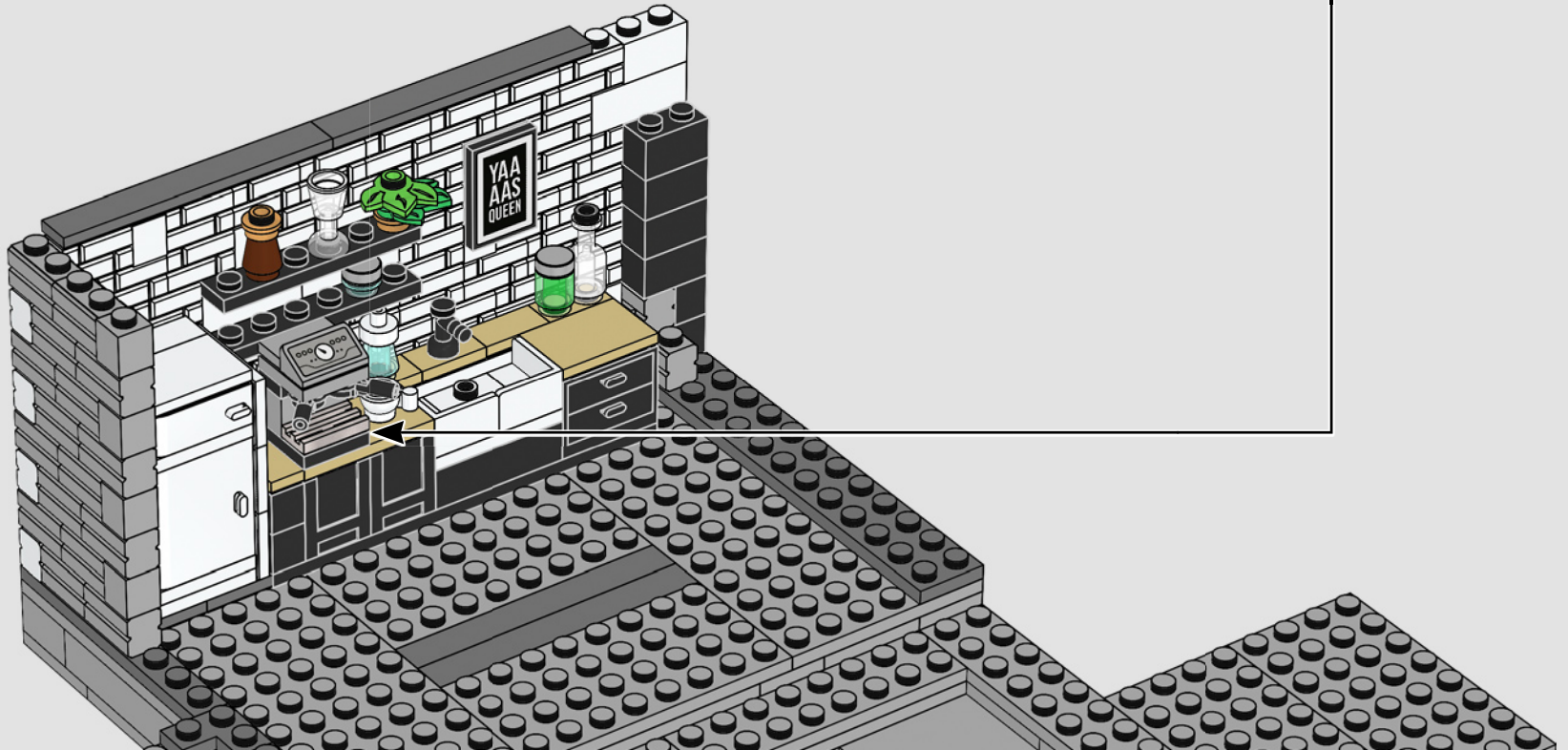
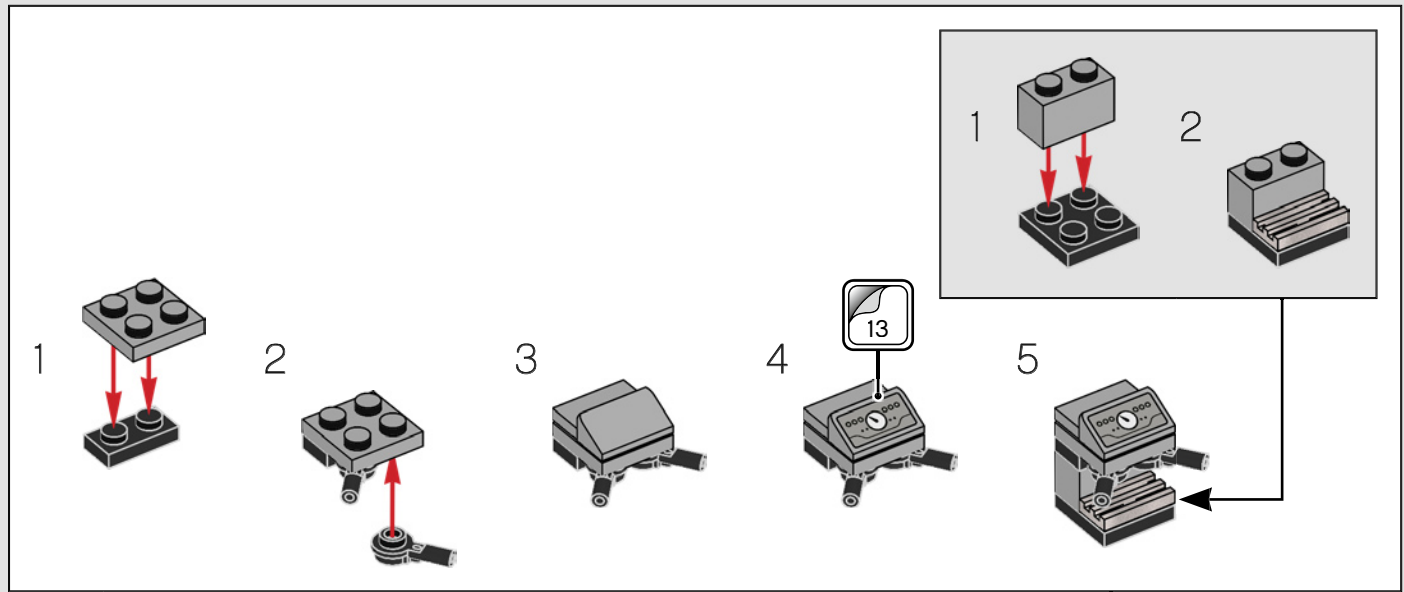

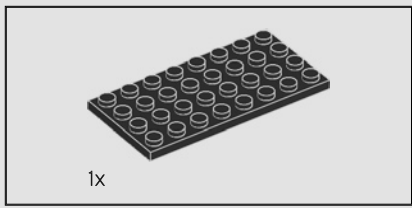

65

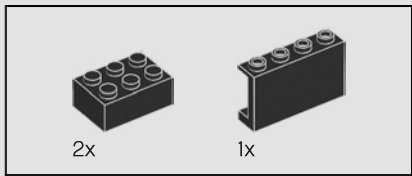
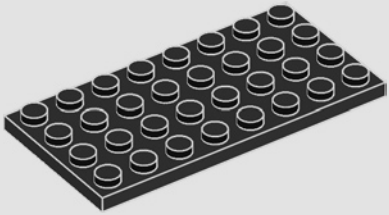

66

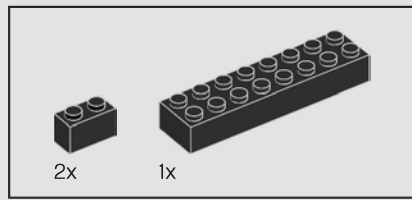
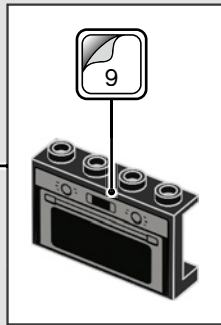
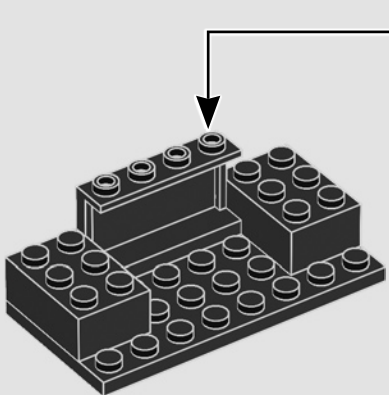

67

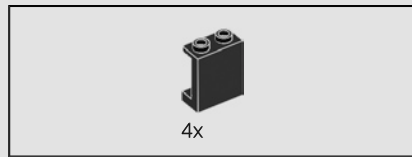
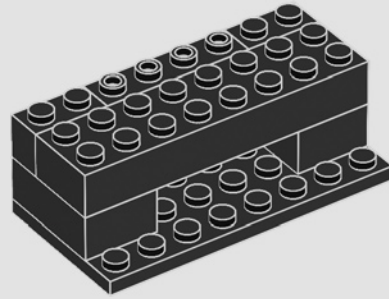

68

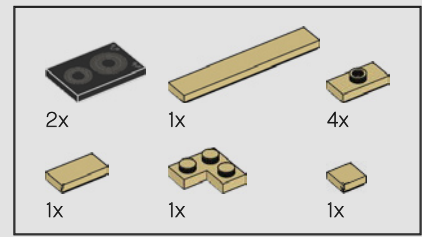
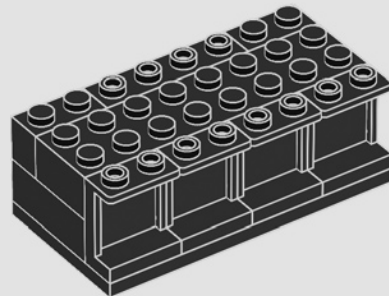

69

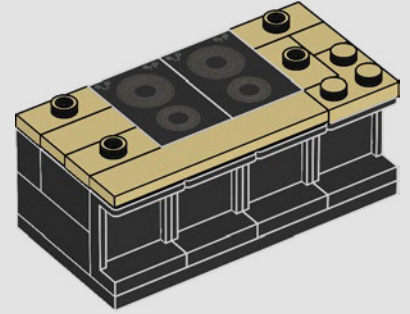

70

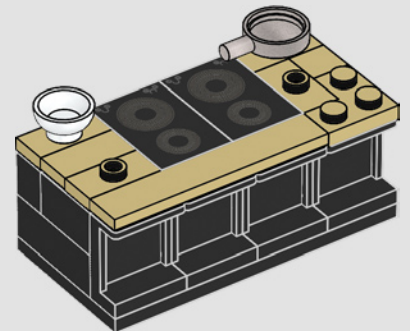

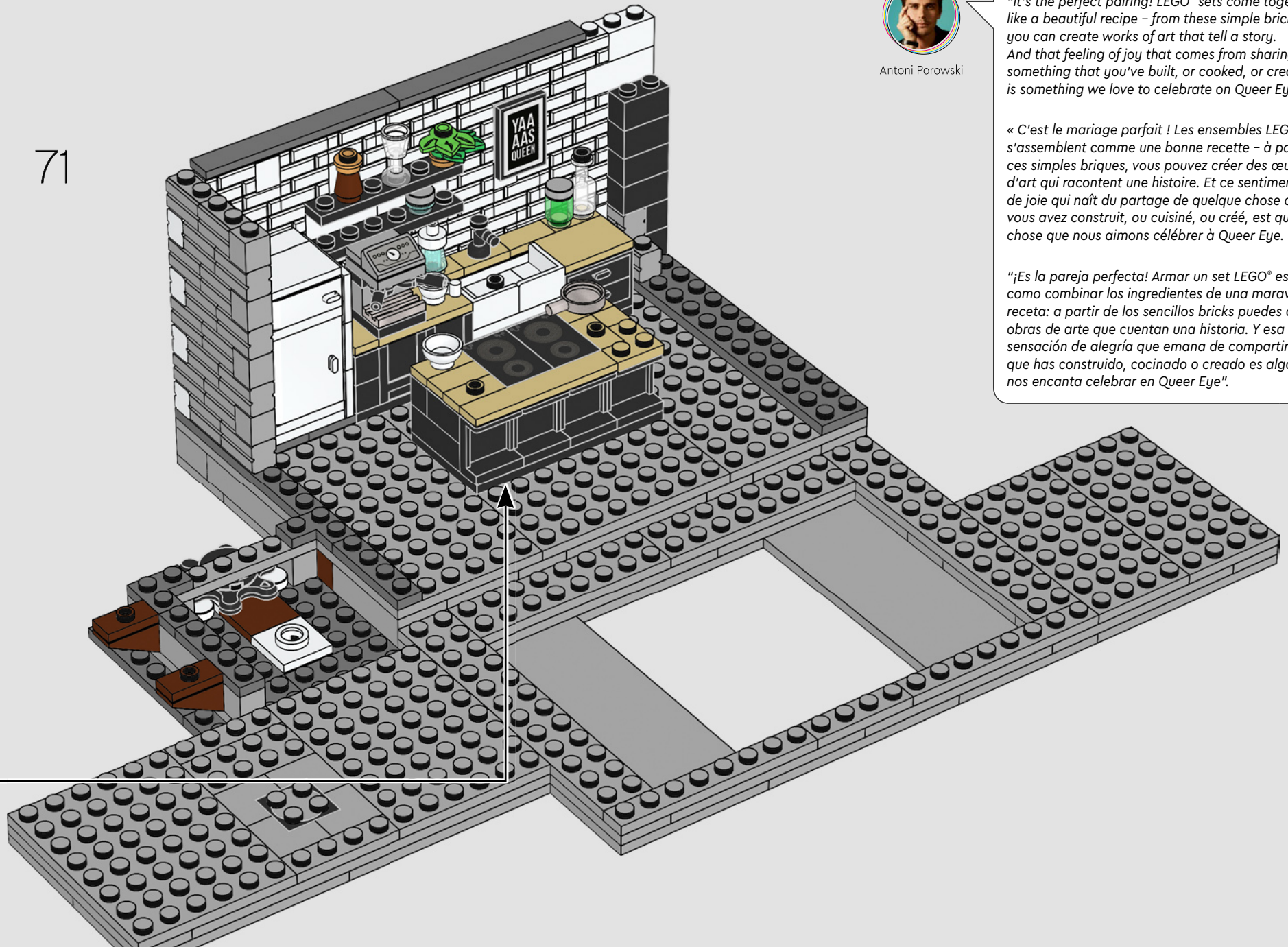

Antoni Porowski

*"It's the perfect pairing! LEGO® sets come together like a beautiful recipe – from these simple bricks you can create works of art that tell a story. And that feeling of joy that comes from sharing something that you've built, or cooked, or created, is something we love to celebrate on Queer Eye."*

*« C'est le mariage parfait ! Les ensembles LEGO® s'assemblent comme une bonne recette – à partir de ces simples briques, vous pouvez créer des œuvres d'art qui racontent une histoire. Et ce sentiment de joie qui naît du partage de quelque chose que vous avez construit, ou cuisiné, ou créé, est quelque chose que nous aimons célébrer à Queer Eye. »*

*"¡Es la pareja perfecta! Armar un set LEGO® es como combinar los ingredientes de una maravillosa receta: a partir de los sencillos bricks puedes crear obras de arte que cuentan una historia. Y esa sensación de alegría que emana de compartir algo que has construido, cocinado o creado es algo que nos encanta celebrar en Queer Eye".*

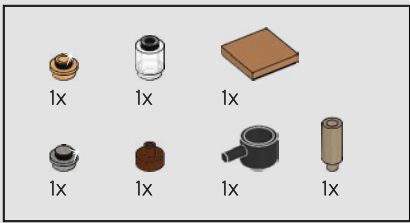

72

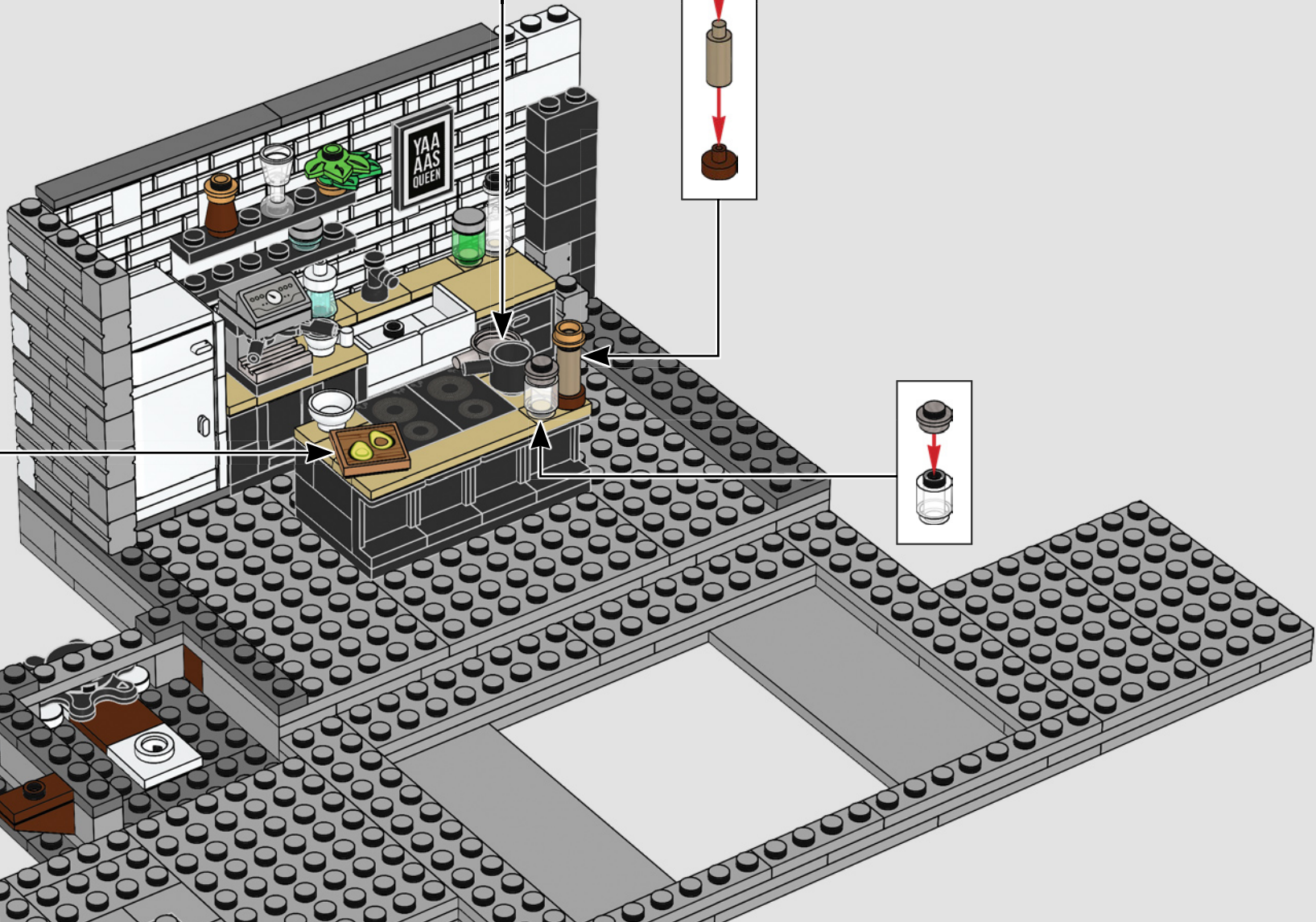
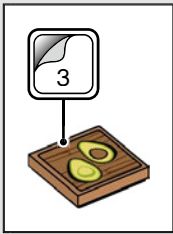
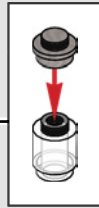
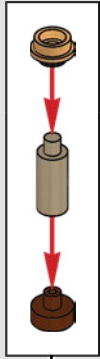
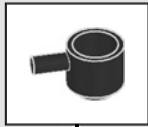

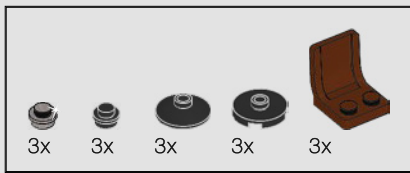

73

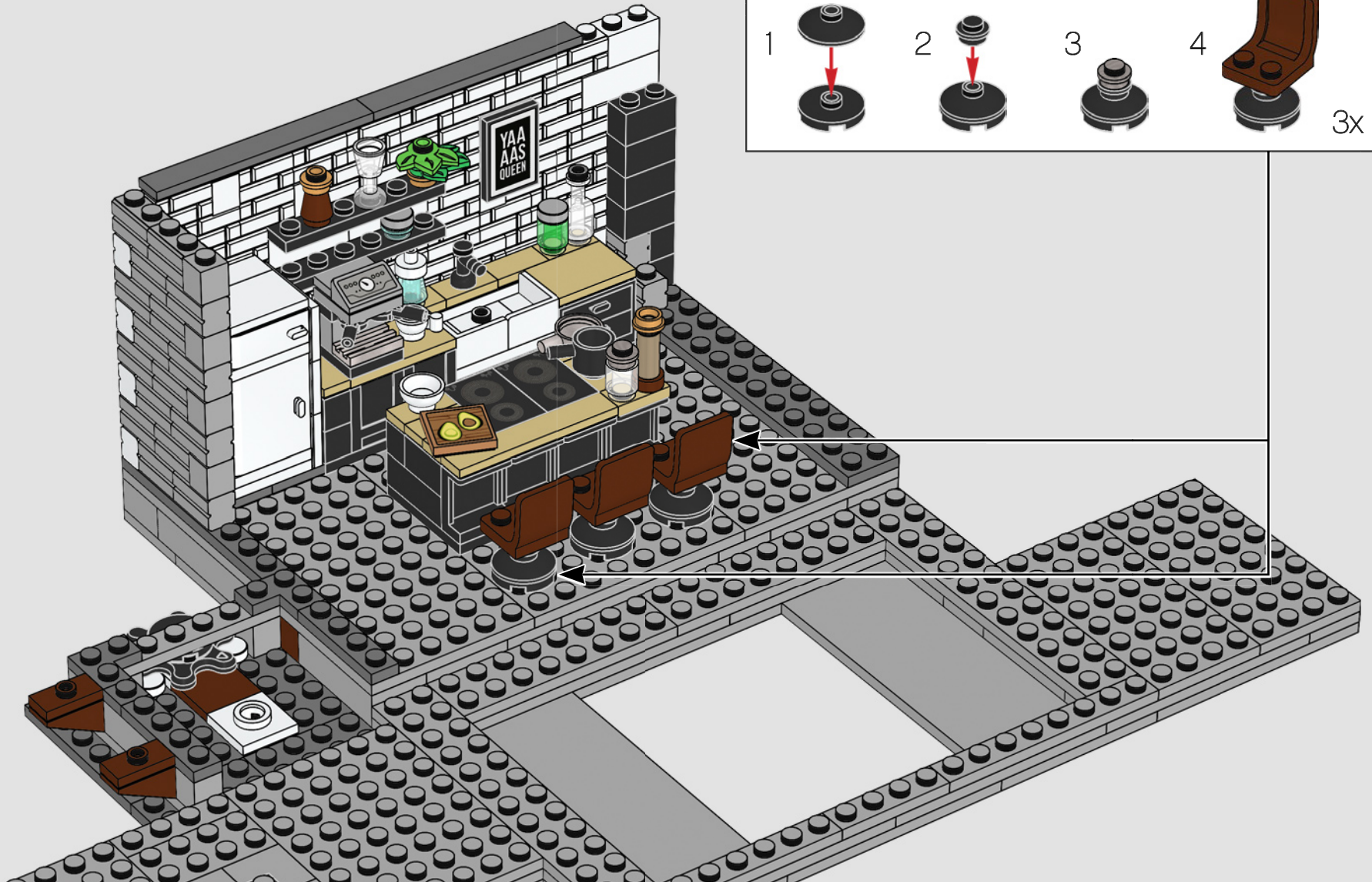
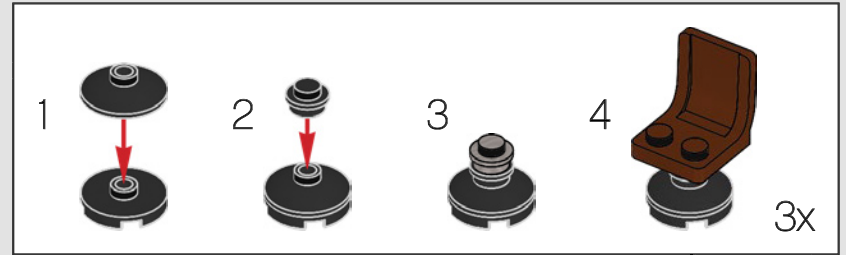

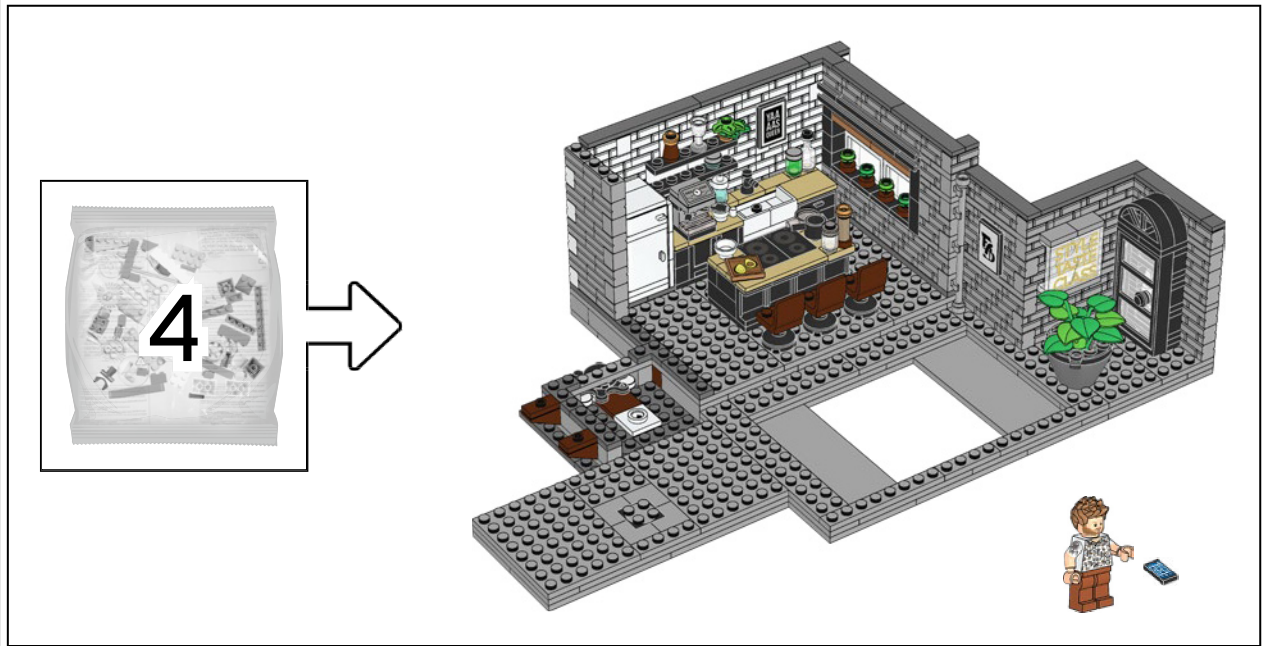

Bobby Berk

*"It's so surreal seeing myself in LEGO®  
Minifigure form – 7-year-old me would be  
mind-blown to know this was a thing!"*

*« C'est surréaliste de me voir en figurine  
LEGO® – le moi de 7 ans aurait été  
abasourdi d'apprendre que ça existe ! »*

*"Verme en forma de minifigura LEGO®  
es una experiencia surrealista: ¡el yo de  
7 años no hubiera podido contener la  
emoción al saber que esto sucedería!"*





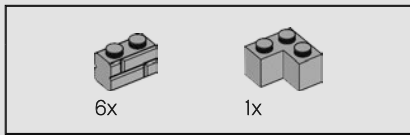

74



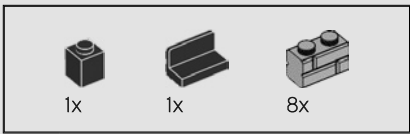

75

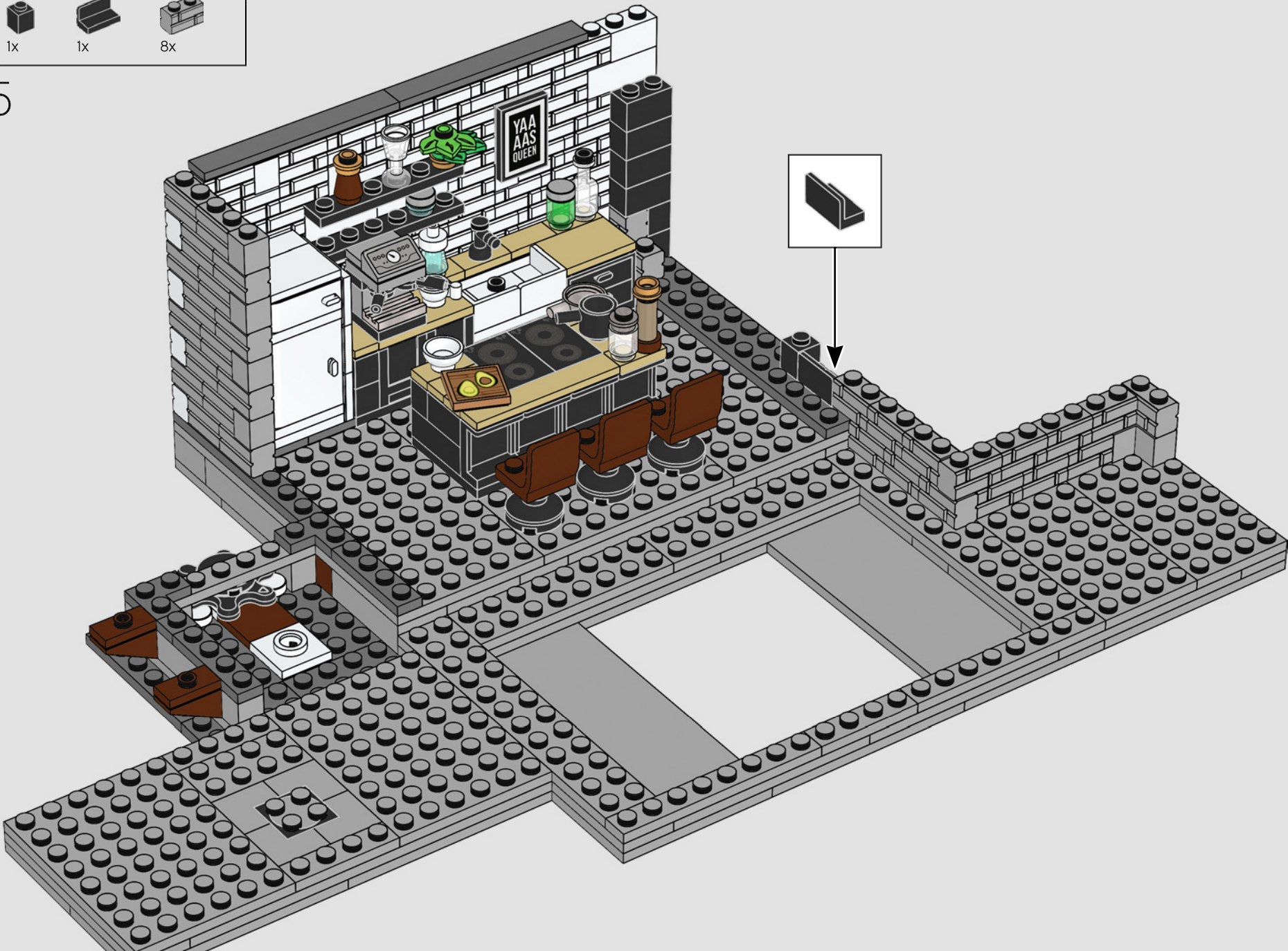

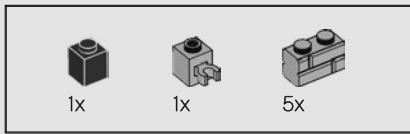

76

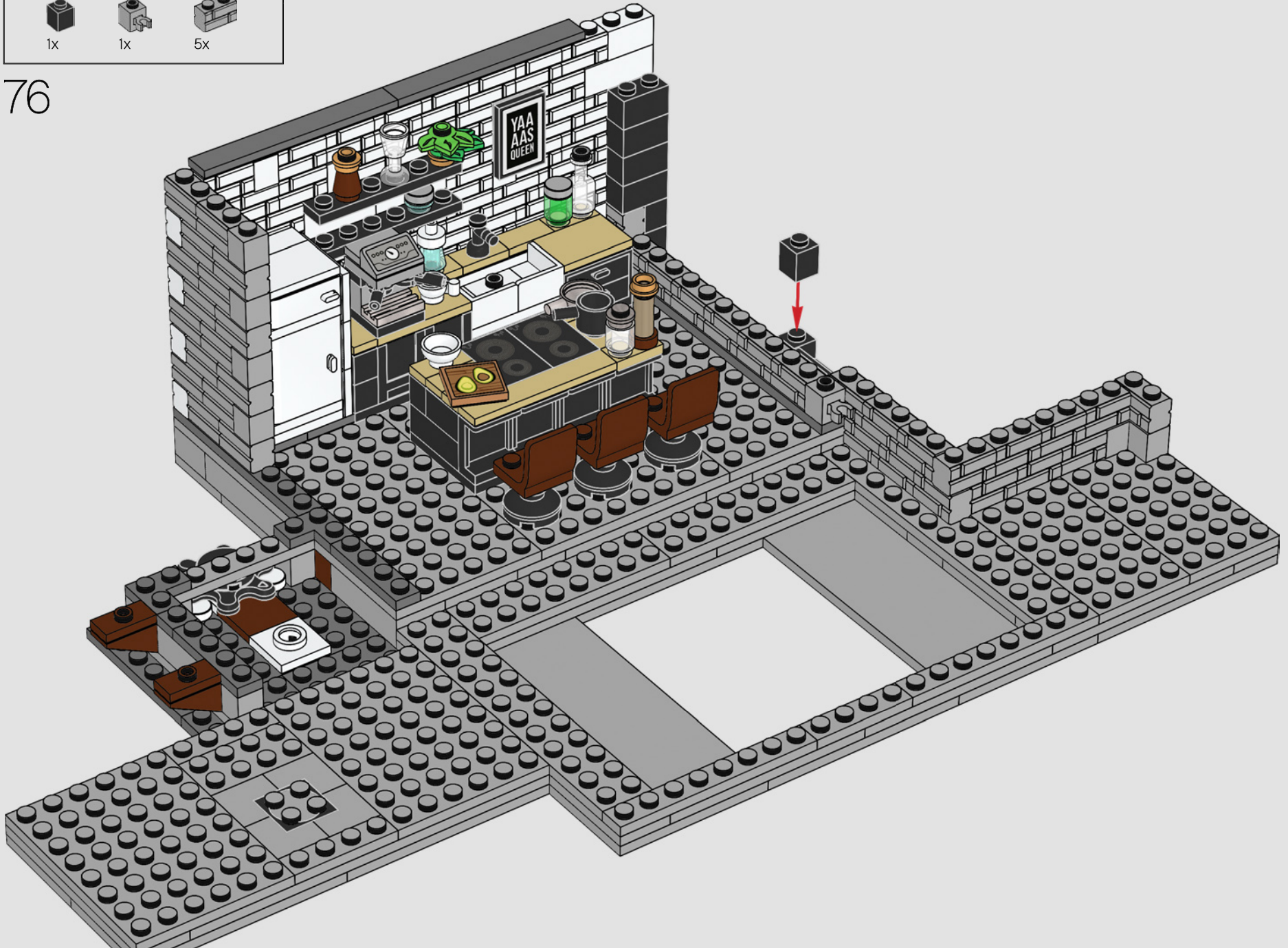

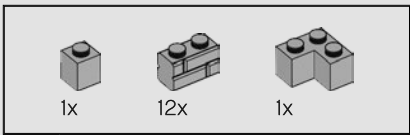

77

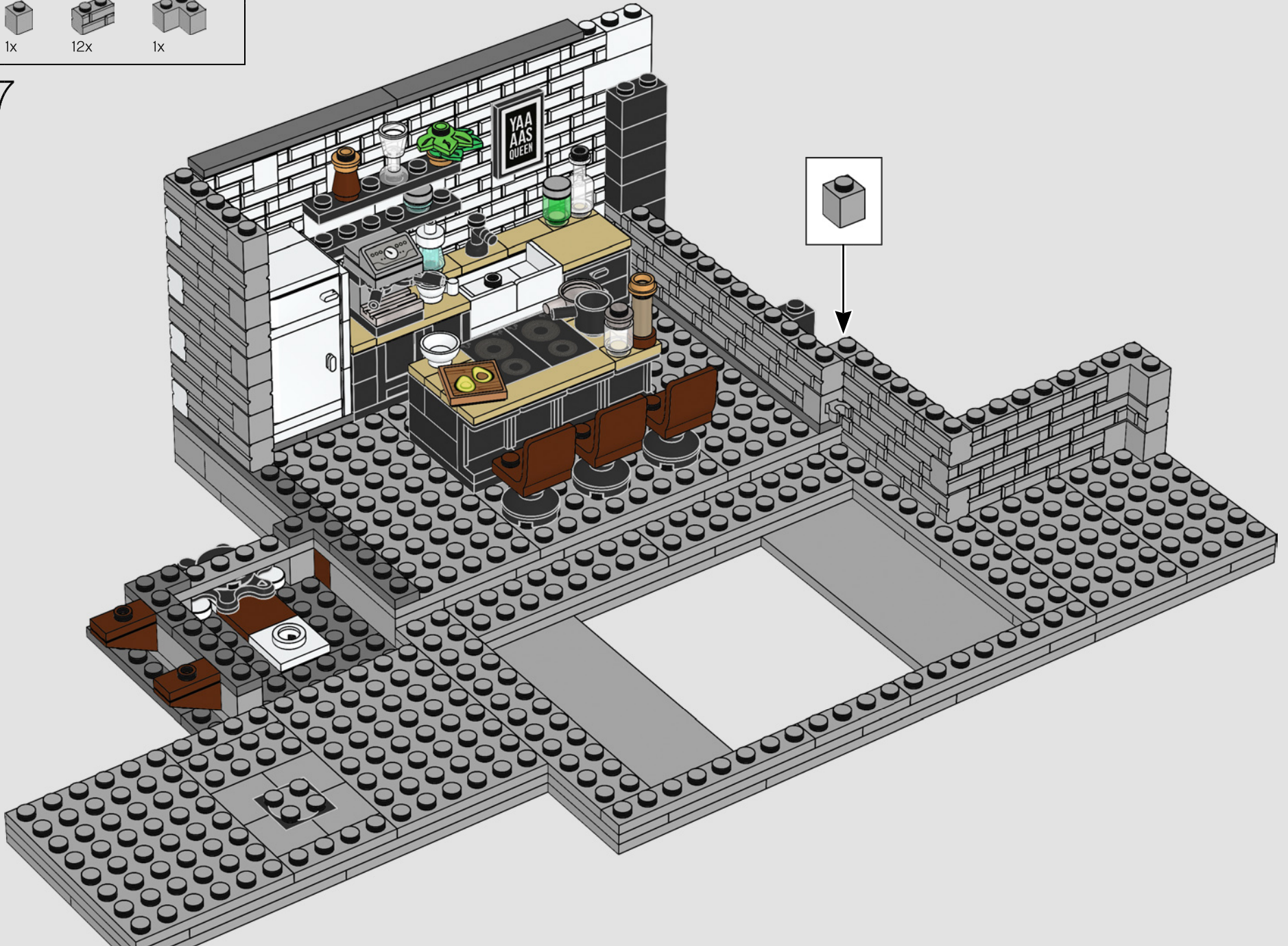



78

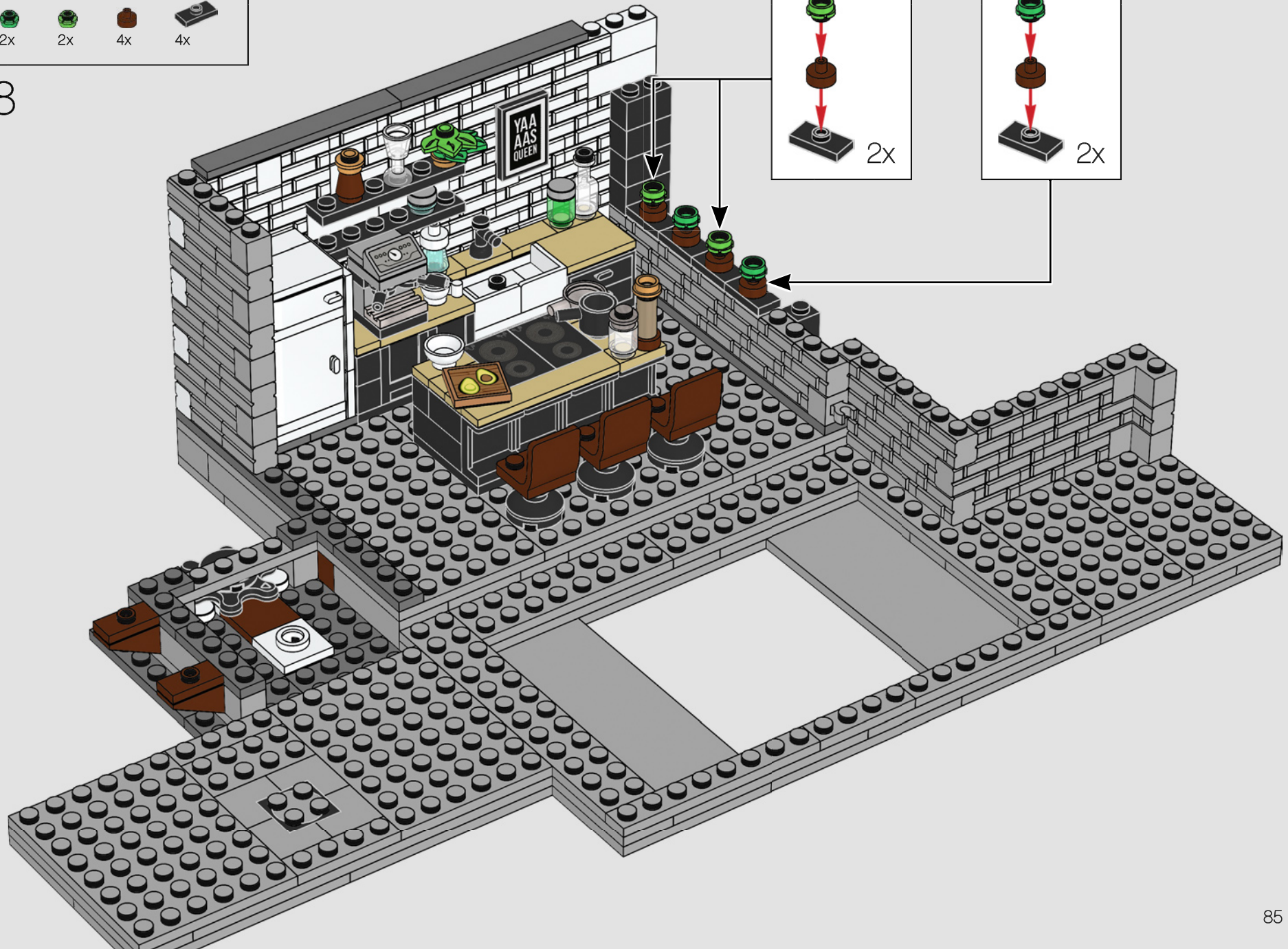
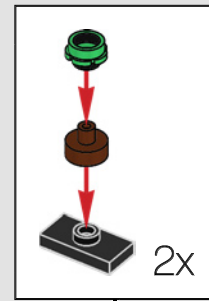
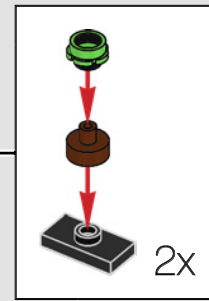

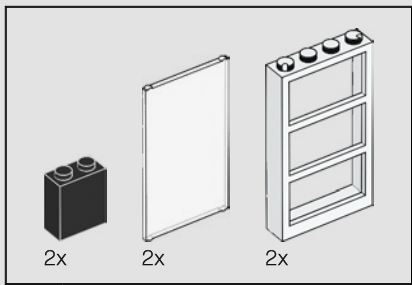

79

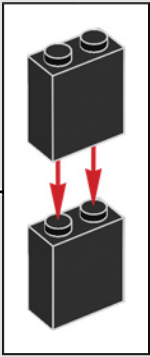
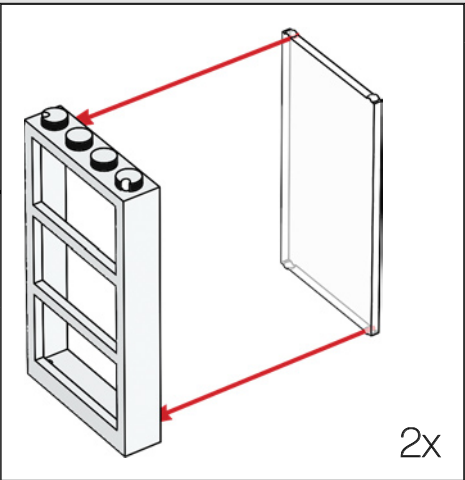
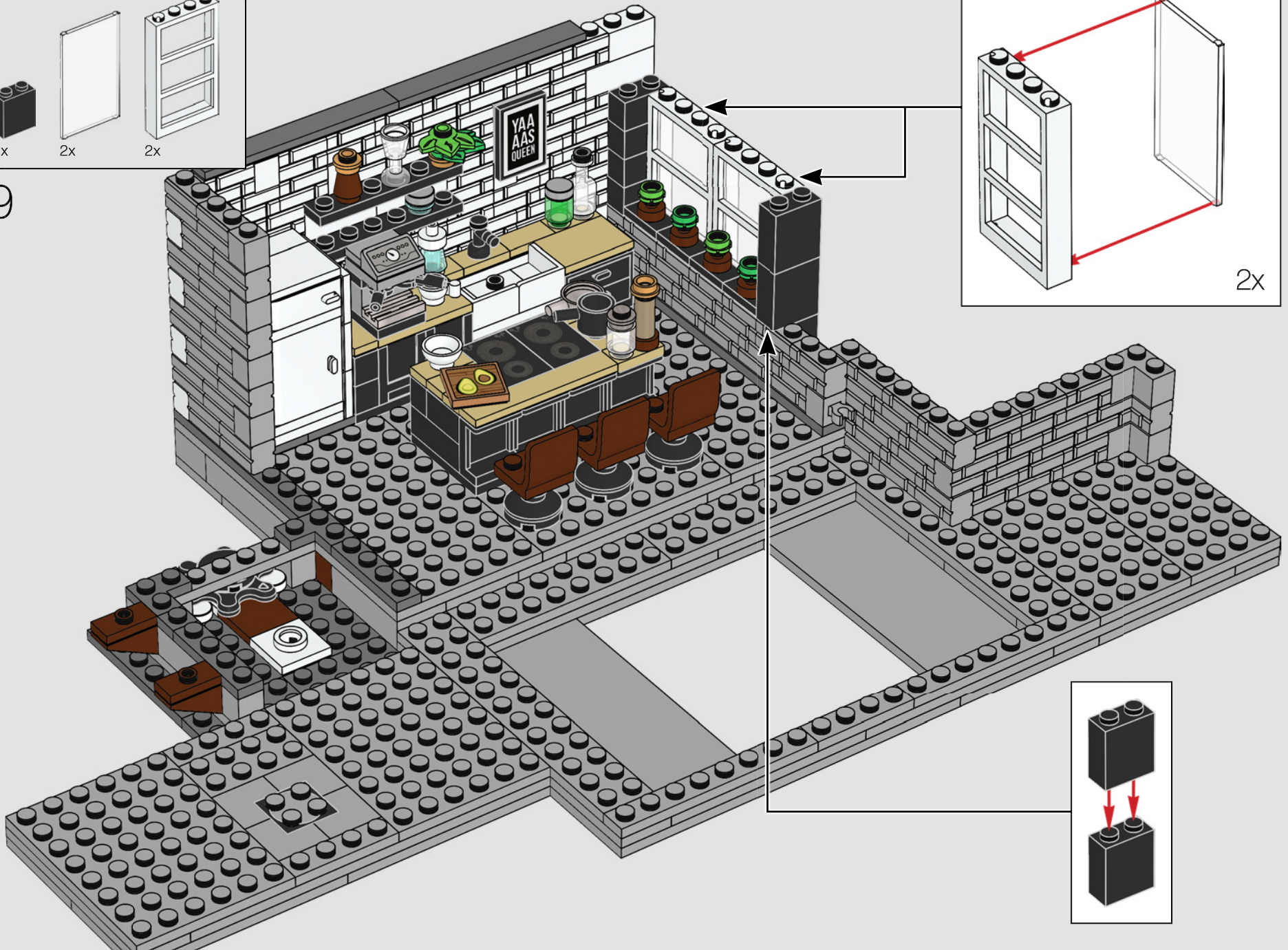

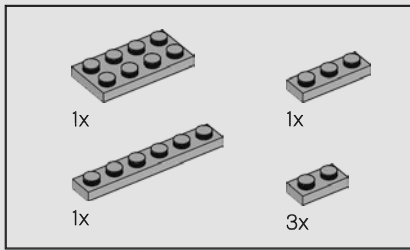

80

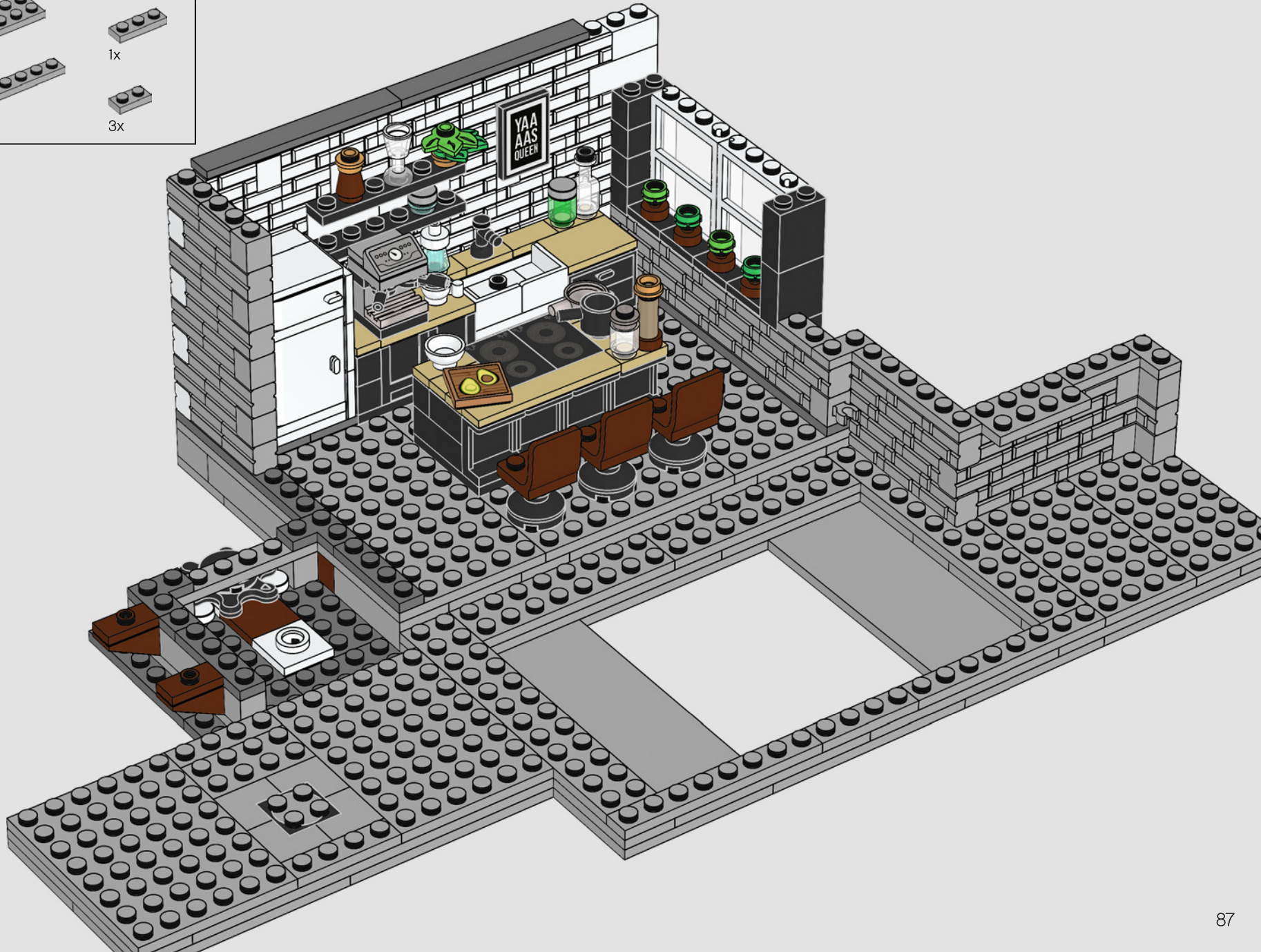

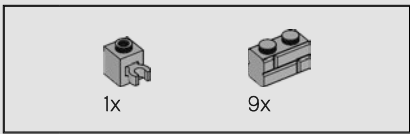

81





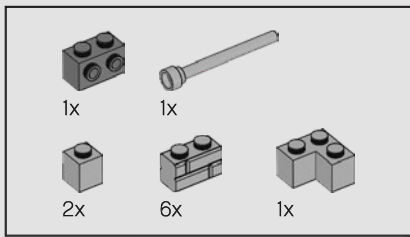

82

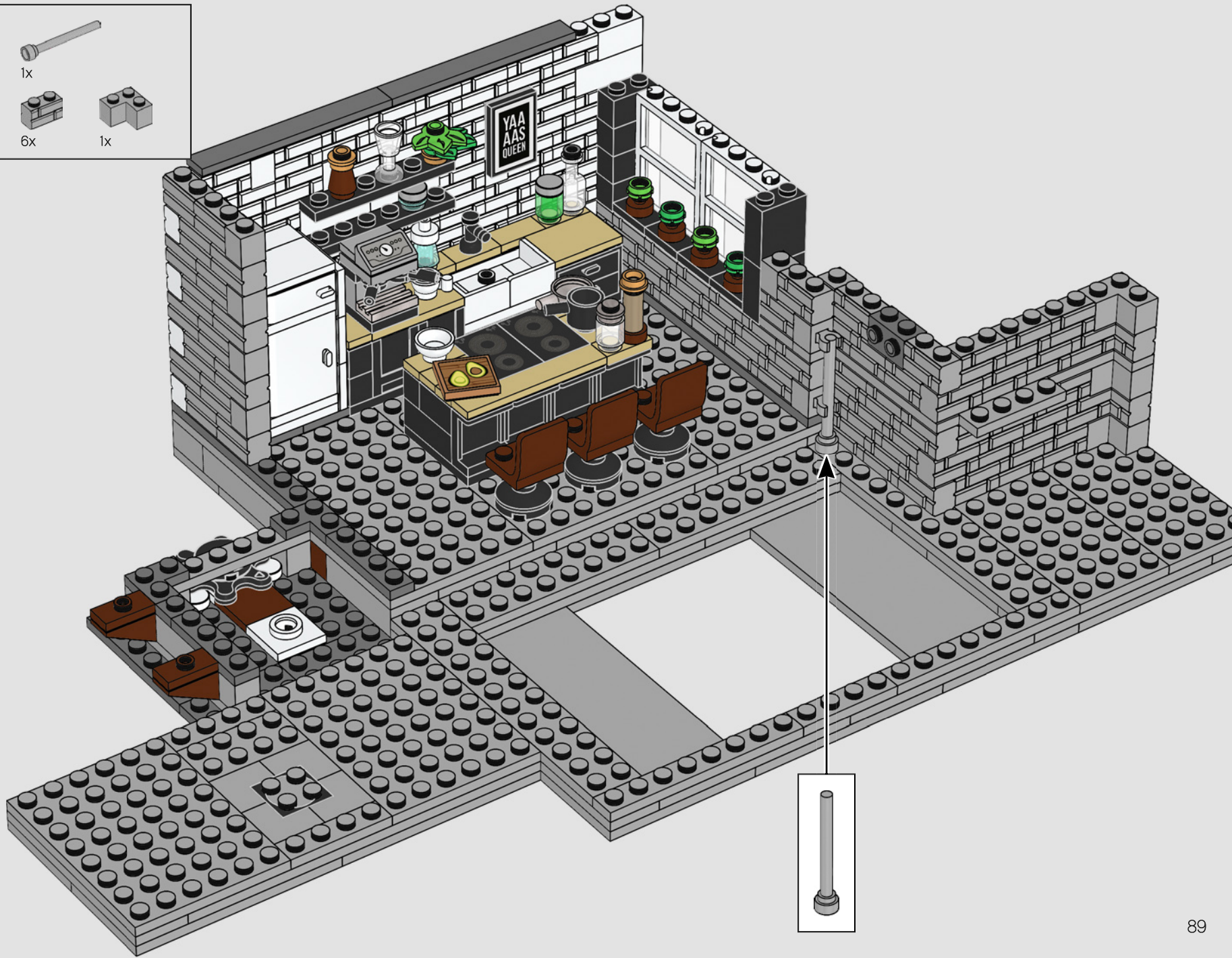

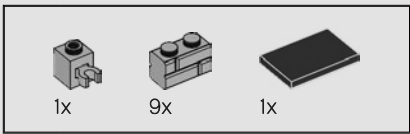

83

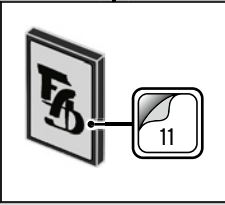
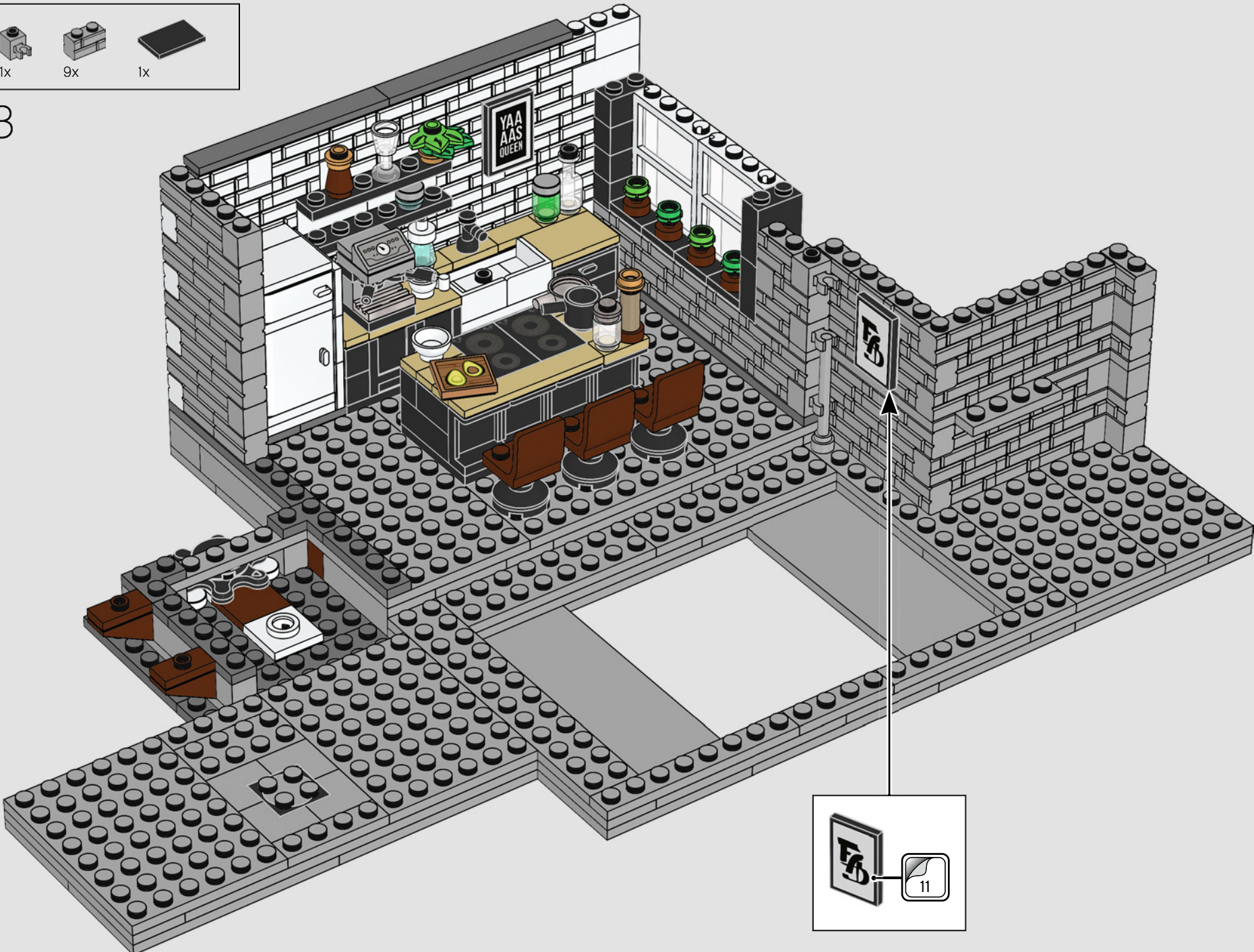

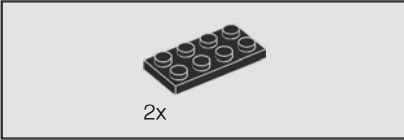
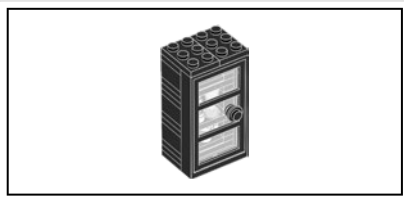

2x

84

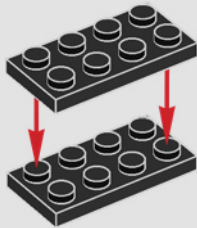

1x

2x

85

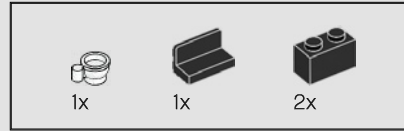
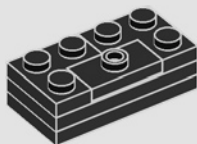

1x

1x

2x

86

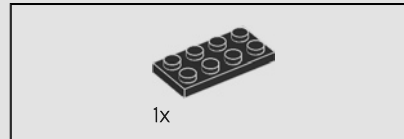
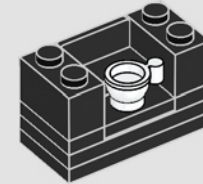

1x

87

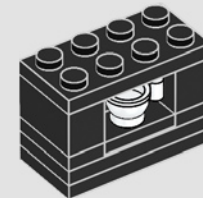



88

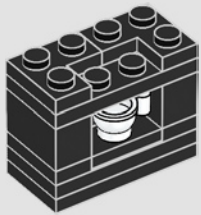

89



90

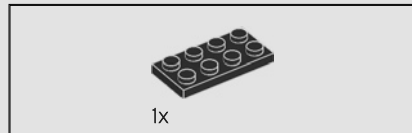

91

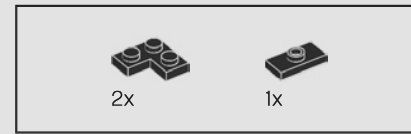

92

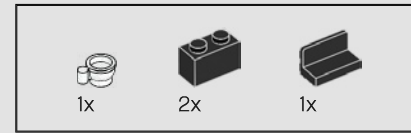

93



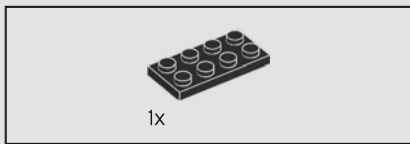

94

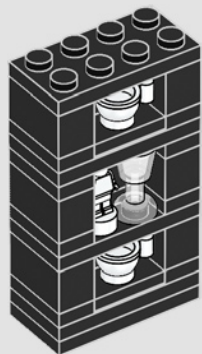

95

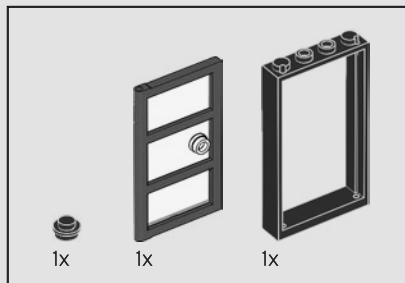
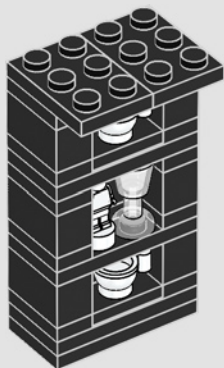

96

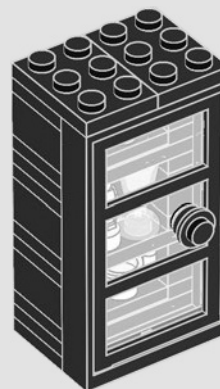
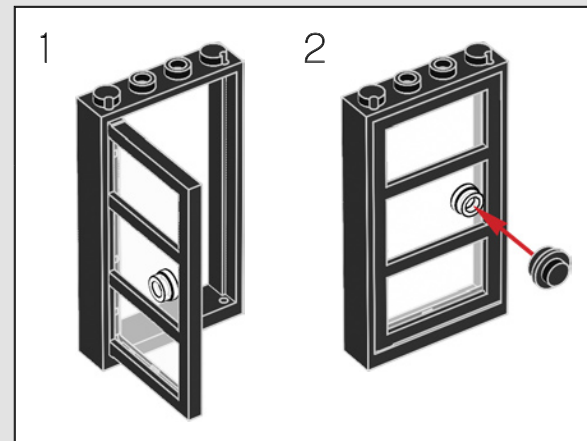

Antoni Porowski

"Growing up, LEGO® was my very favorite toy. I would build cities, pirate ships, destroy them, then start all over again. It's pretty incredible to think that young kids will now have LGBTQ+ options to play and build with. I'm honored to be a part of this special partnership. Ten-year-old Antoni is internally screaming."

« Quand j'étais petit, LEGO® était mon jouet préféré. Je construisais des villes, des bateaux de pirates, je les détruisais, puis je recommençais. C'est assez incroyable de penser que les jeunes enfants pourront maintenant jouer et construire avec des options LGBTQ+. Je suis honoré de faire partie de ce partenariat unique. Le petit Antoni de 10 ans crie intérieurement. »

"Cuando era niño, mis juguetes favoritos eran LEGO®. Construía ciudades y barcos piratas, los destruía y volvía a empezar. Es increíble pensar que los niños ahora tendrán opciones LGBTQ+ para jugar y construir. Me siento honrado de formar parte de esta alianza especial. El Antoni de diez años que llevo dentro está gritando de emoción".

97

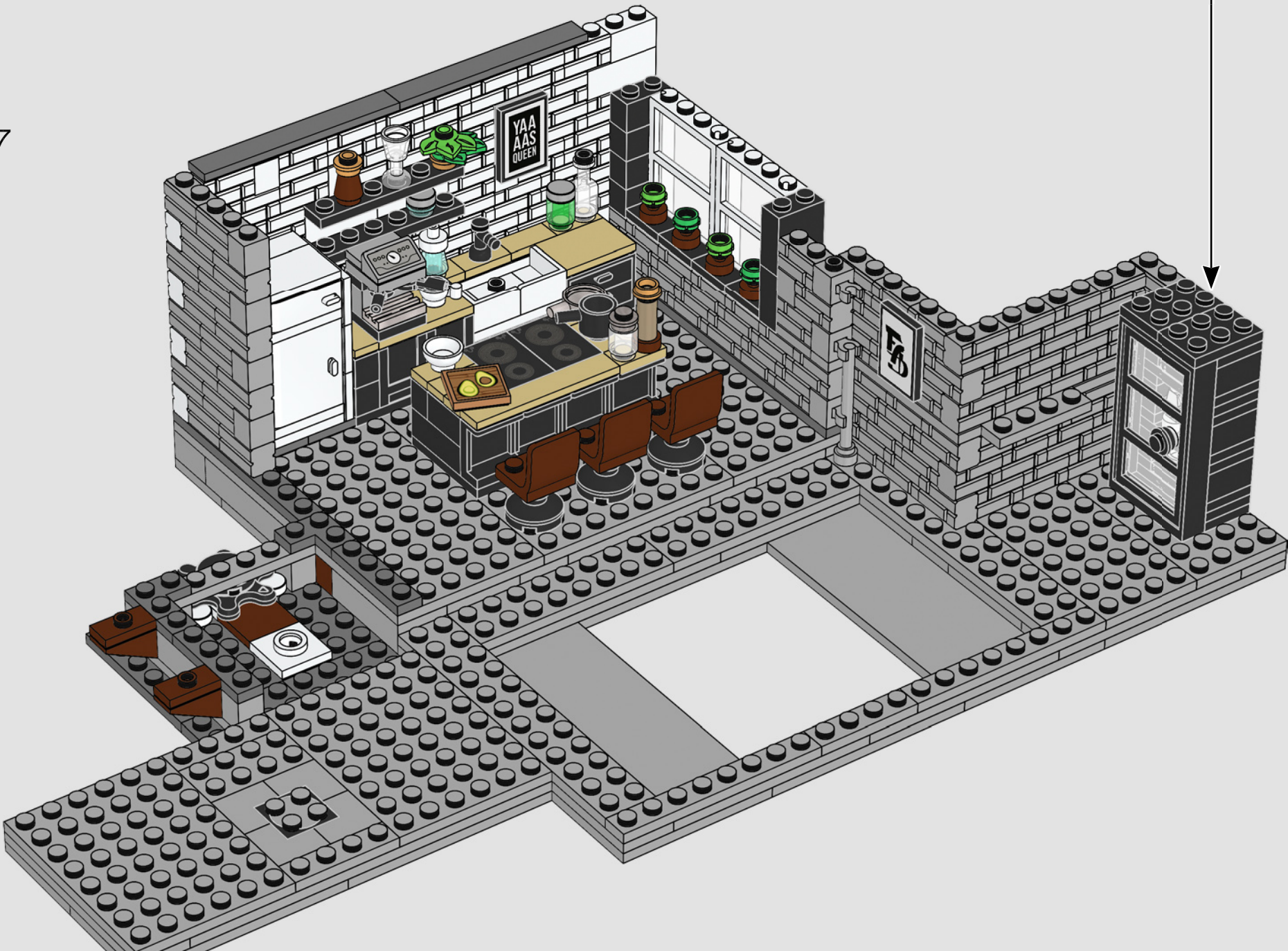

94

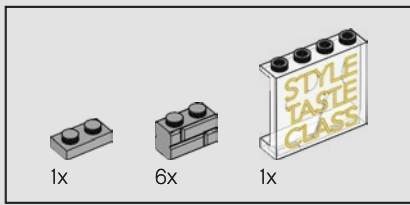

98

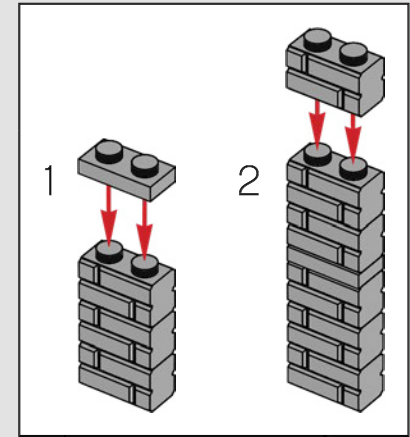
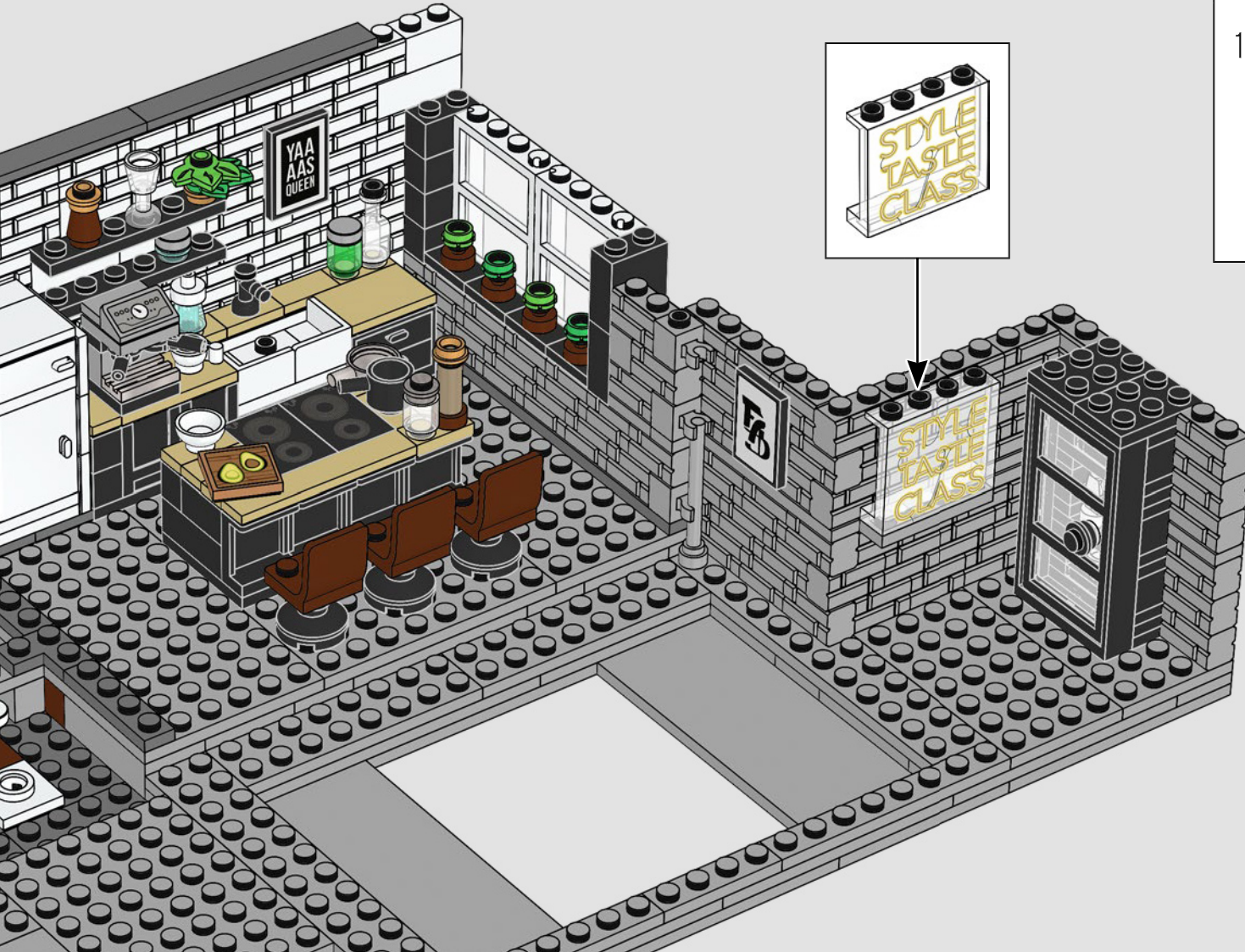

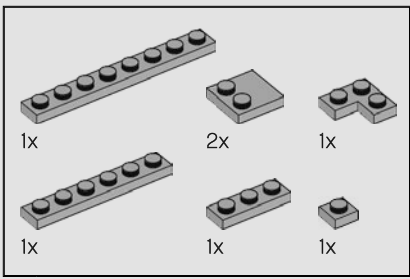

99





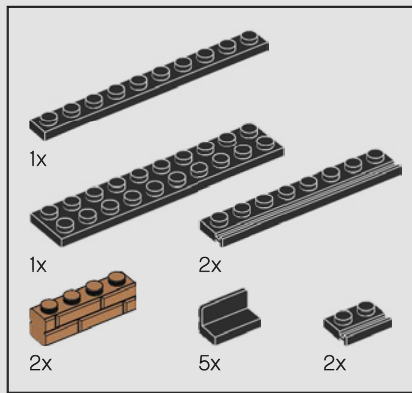

100



Tan France

"We, the Fab Five, are all big kids at heart, and what we do on *Queer Eye* sometimes feels so much more like play than work. It seems such a natural fit for us to collaborate on this LEGO® set, such a well-loved toy for kids of all ages!"

« Nous, les Fab Five, sommes tous de grands enfants dans l'âme, et ce que nous faisons à *Queer Eye* ressemble parfois beaucoup plus à du jeu qu'à du travail. Il semble tout à fait naturel pour nous de collaborer sur cet ensemble LEGO®, un jouet tant adoré par les enfants de tous âges ! »

"En el fondo de nuestros corazones, los Fab Five somos solo niños grandes, y lo que hacemos en *Queer Eye* a veces se siente más como si fuera un juego que como trabajo de verdad. Por eso, colaborar en este set LEGO®, un juguete tan querido por niños de todas las edades, ¡es algo que se nos dio con toda naturalidad!"

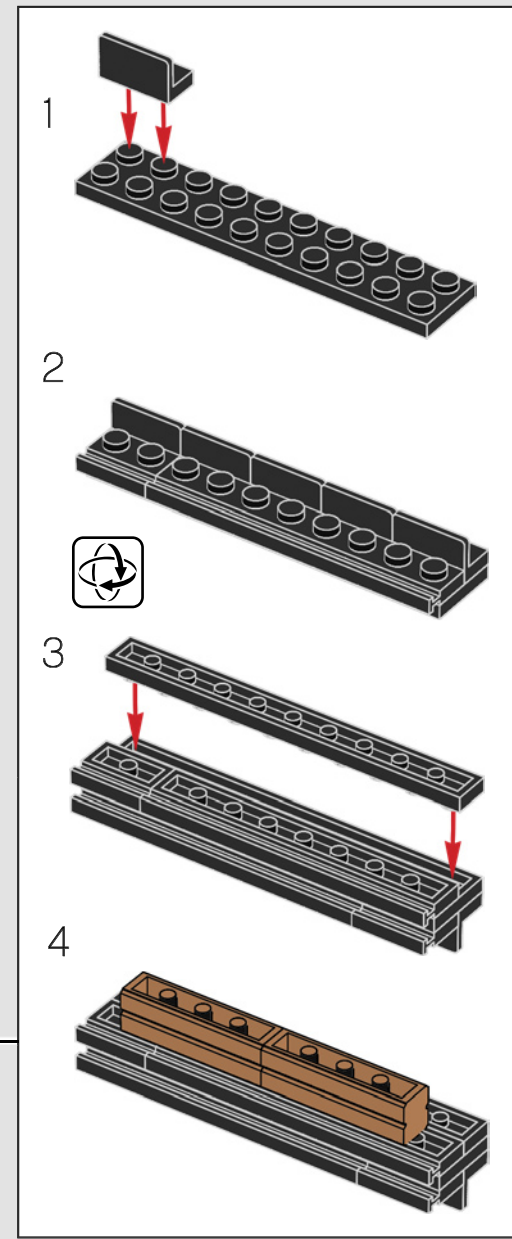

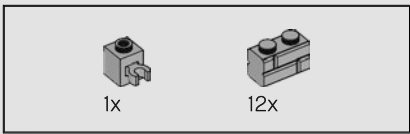

101



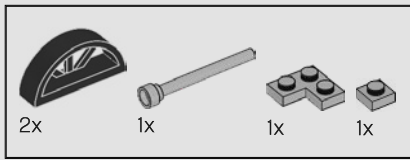

102

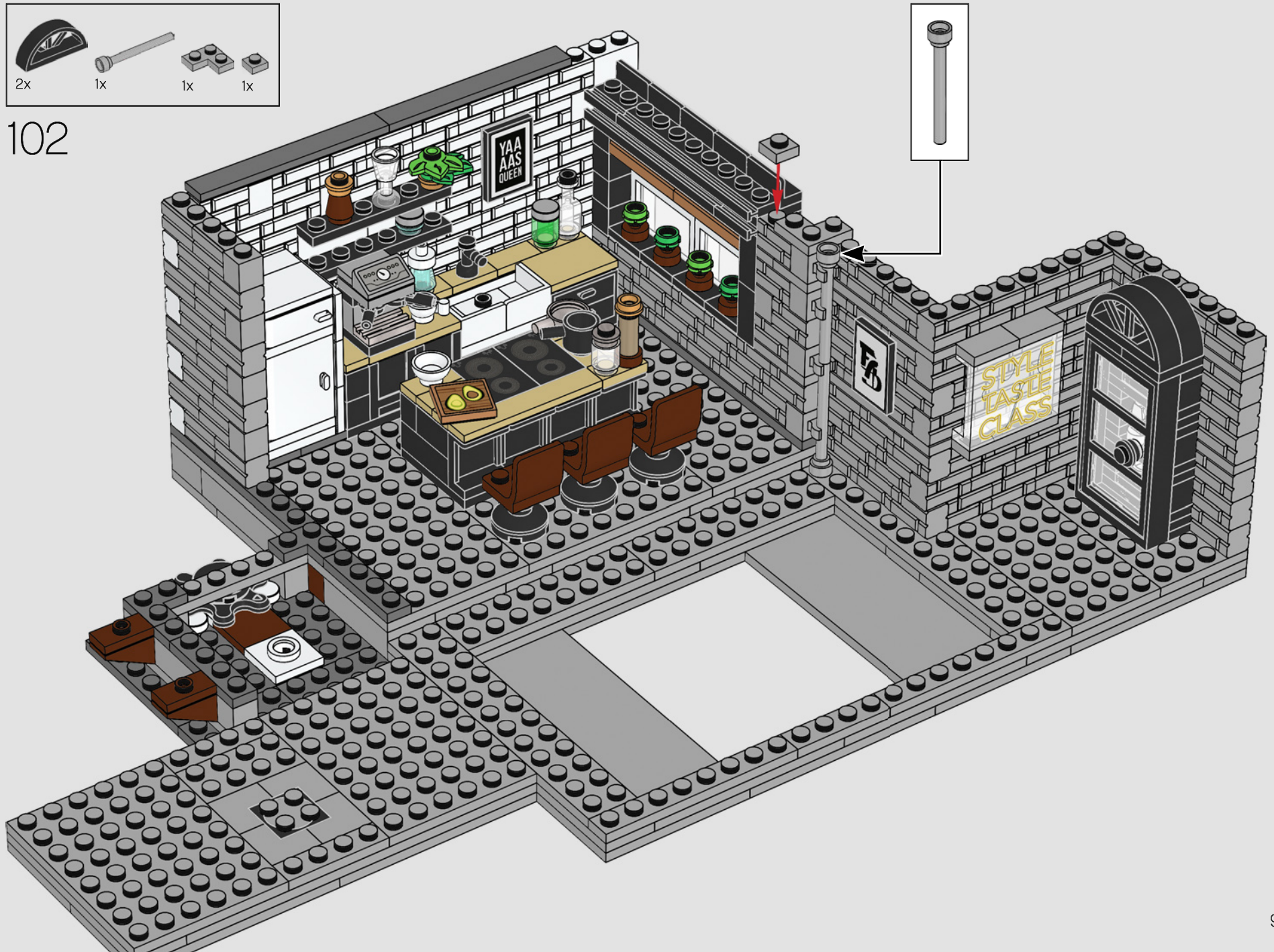



7x

103

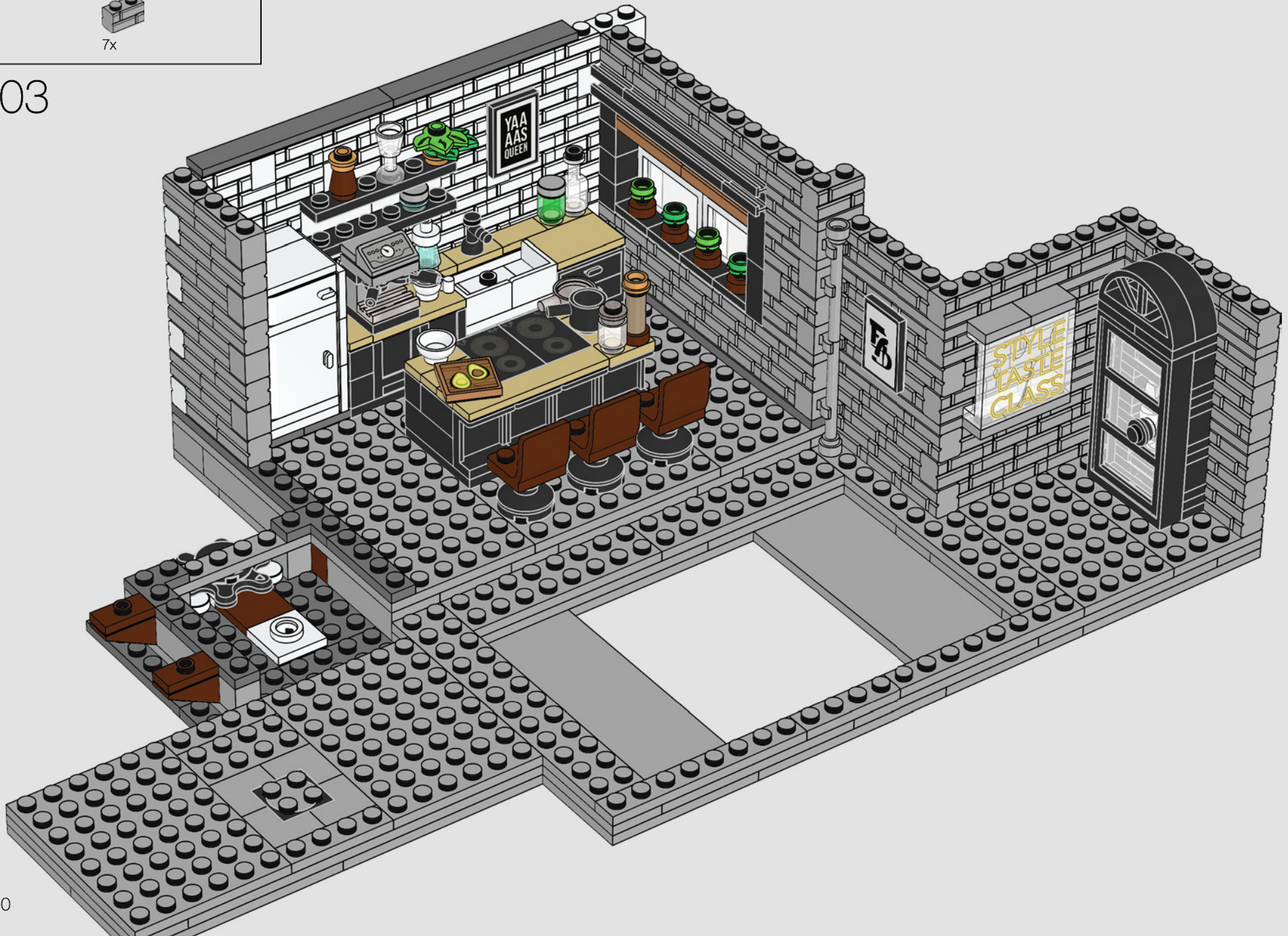

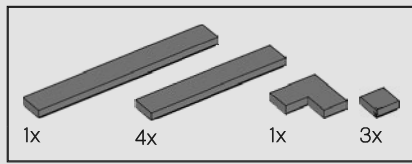

104



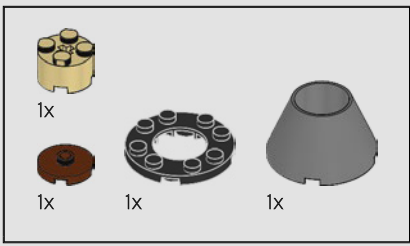

105

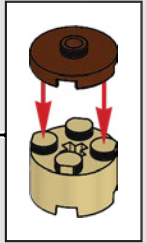
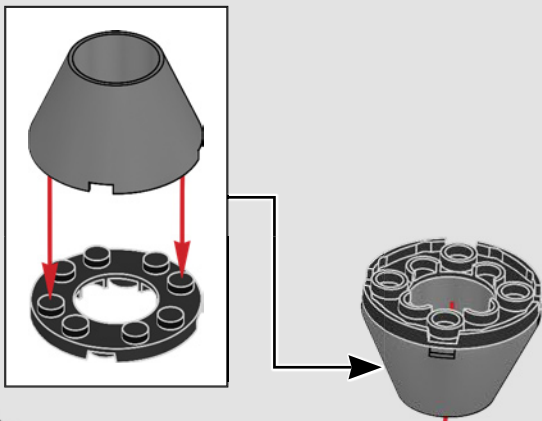

102

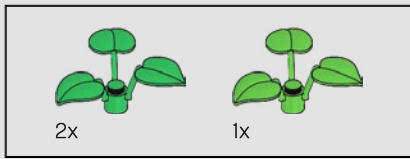

106

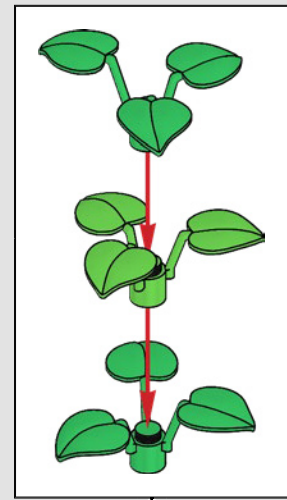
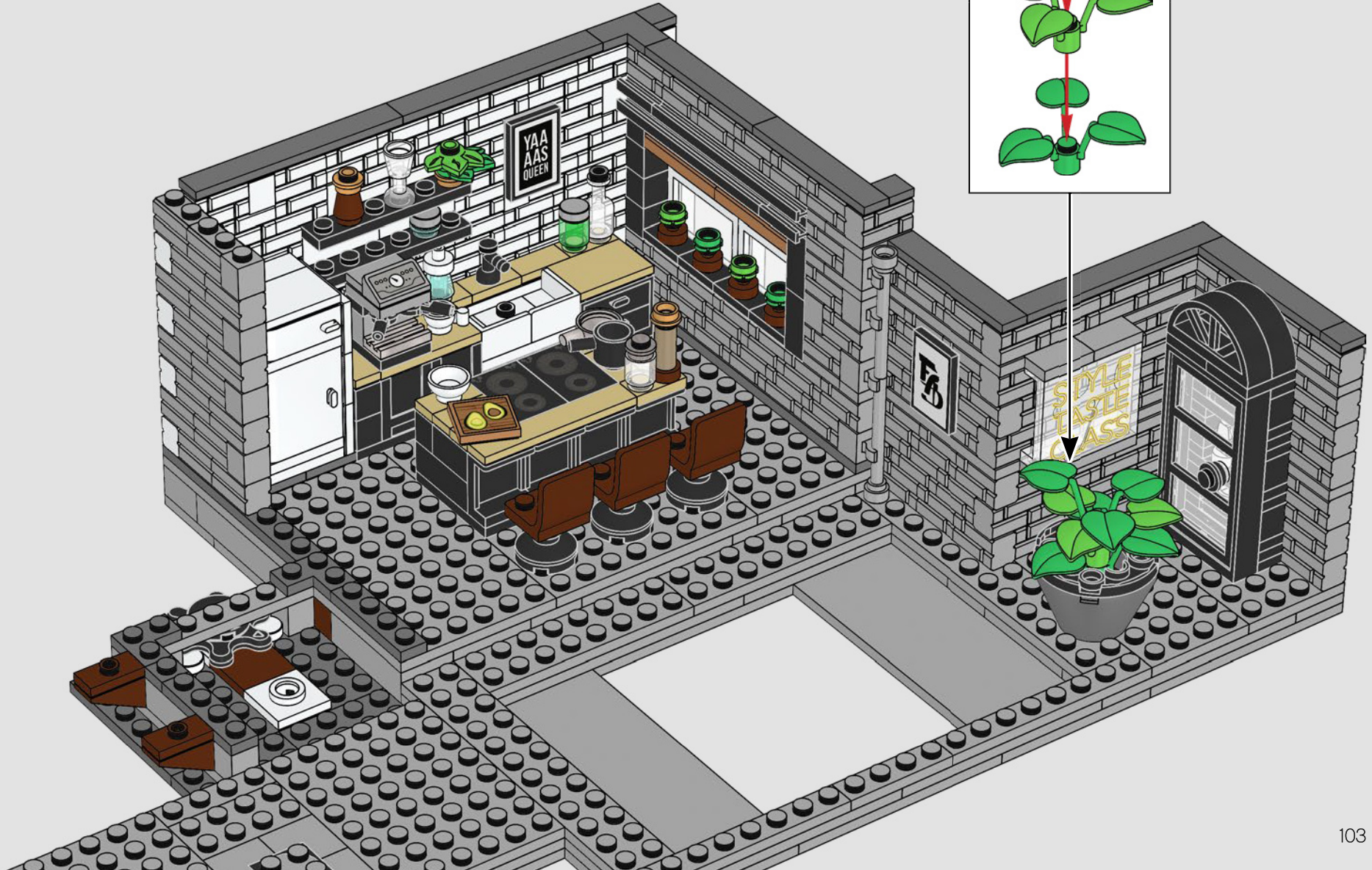

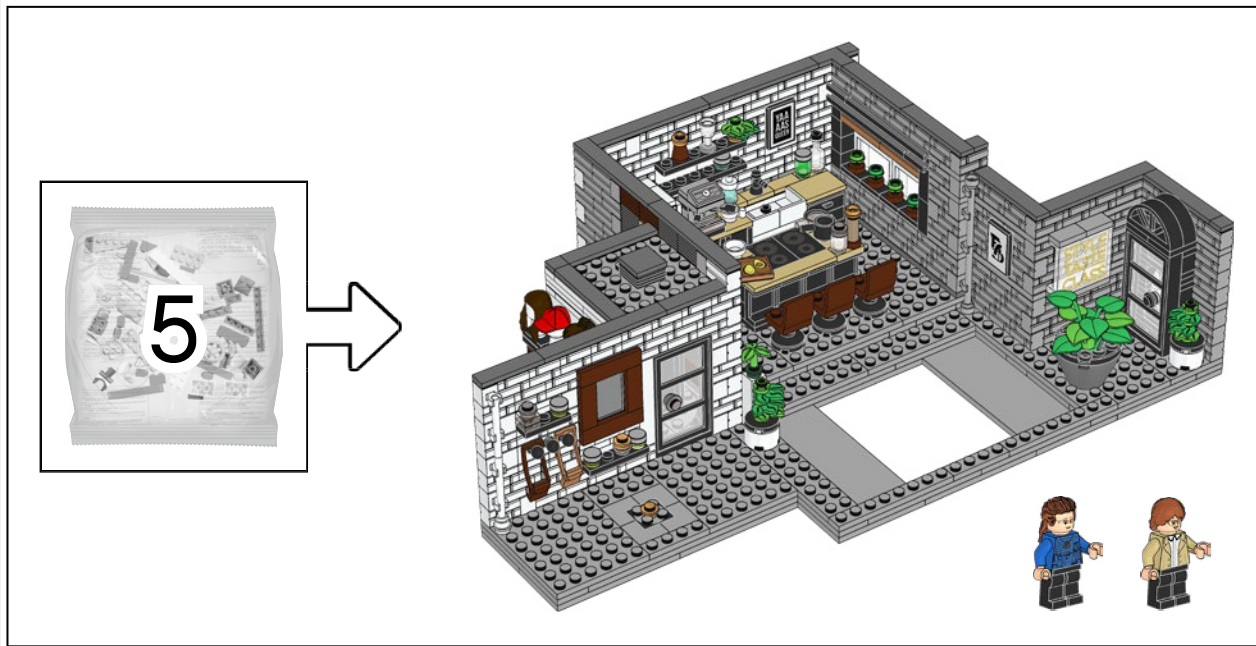

Jonathan Van Ness

*"So happy this set comes with Kathi Dooley! She is my childhood hero and means so much to me. Plus, I get to play cutting off her mullet as many times as I want now."*

*« Je suis tellement heureux que cet ensemble comprenne Kathi Dooley ! C'est l'héroïne de mon enfance et elle compte tellement pour moi. De plus, je peux maintenant couper ses cheveux autant de fois que je le désire. »*

*"Me encanto ver a Kathi Dooley representada en este set. Significa mucho para mí, ya que es mi heroína de la niñez. Además, ¡ahora puedo jugar a cortarle el cabello tantas veces como quiera!"*





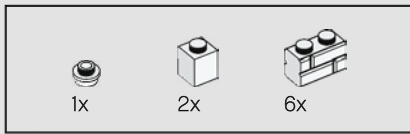

107



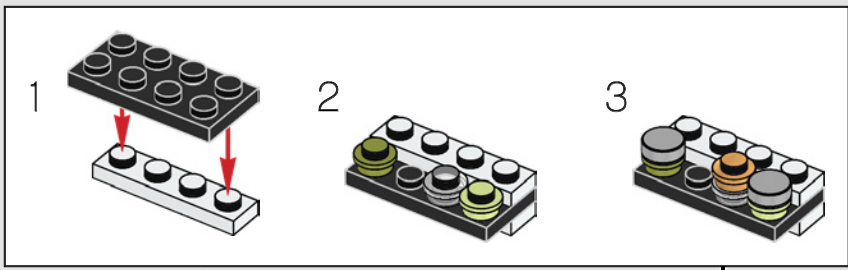
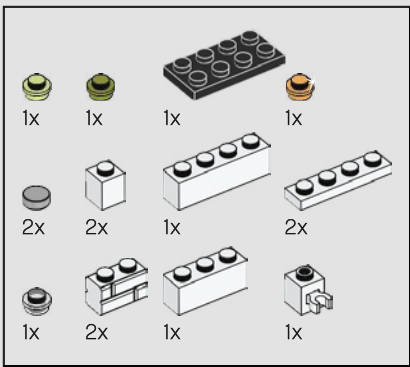

108



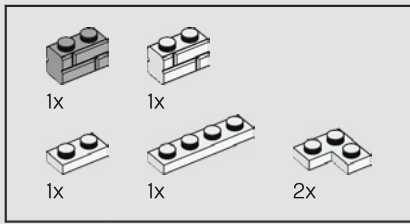

109



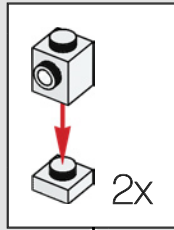
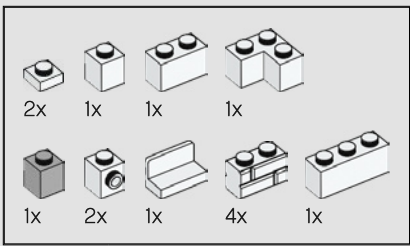

110



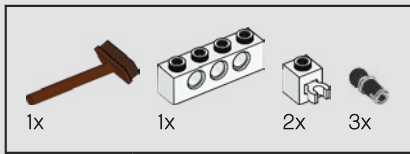

111

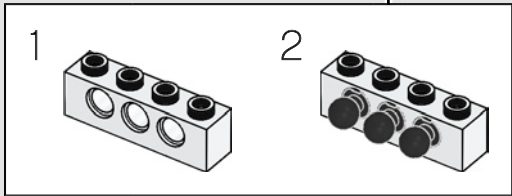
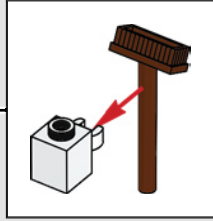

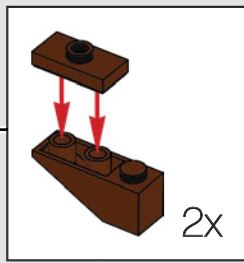
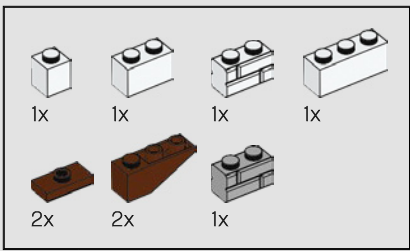

112



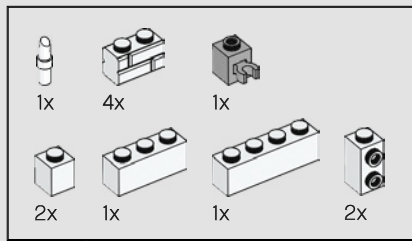

113

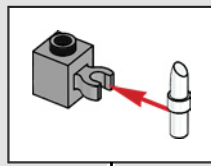

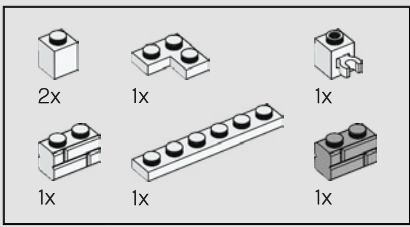

114





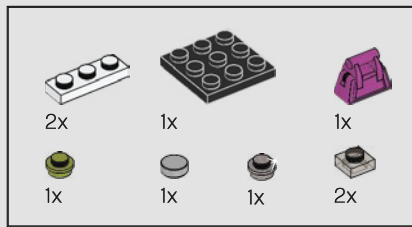

115

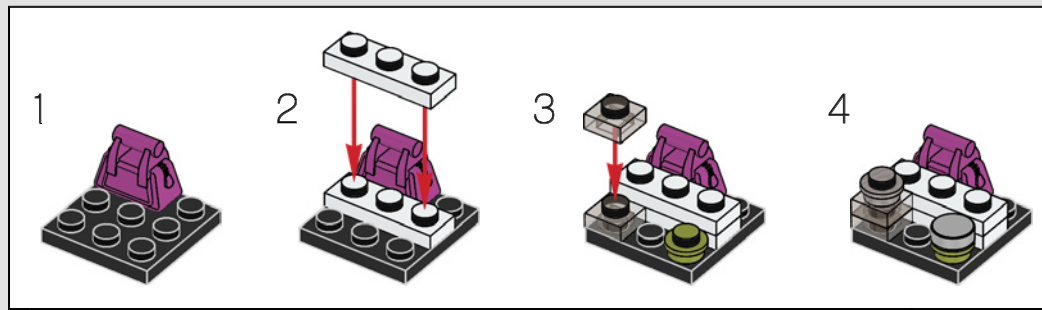

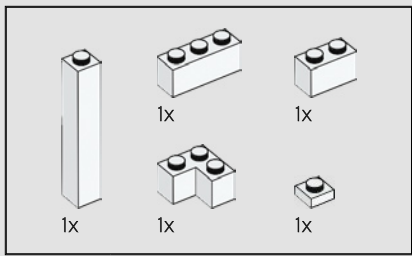

116



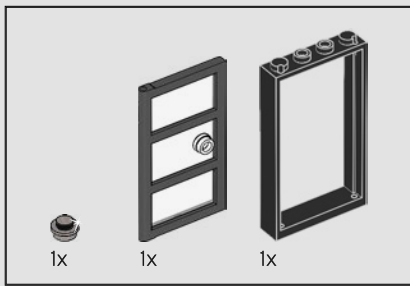

117

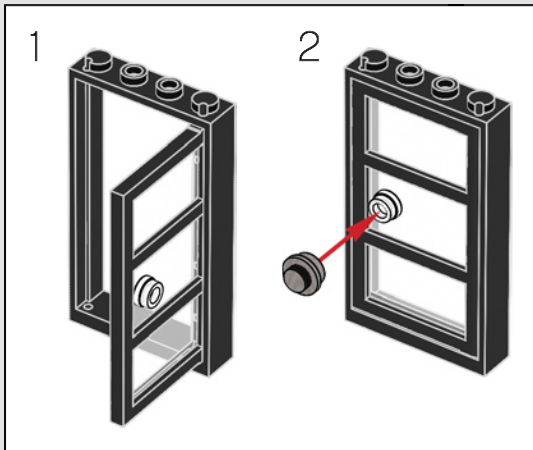

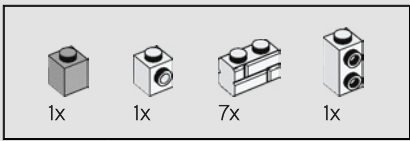

118



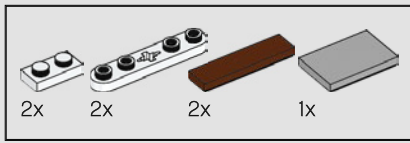

119

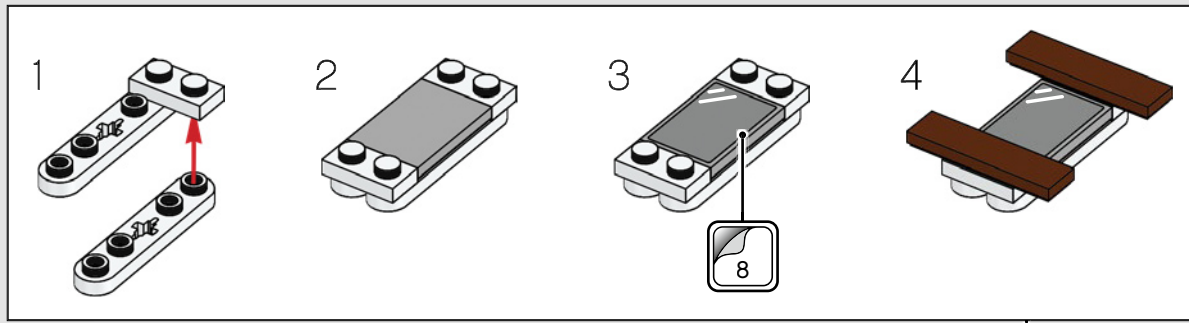

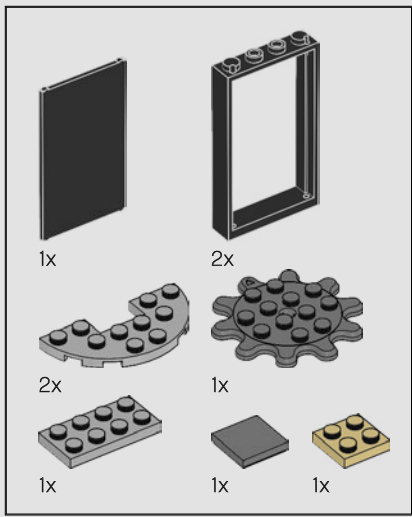

120

1

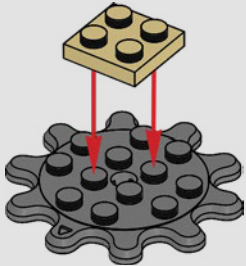

2

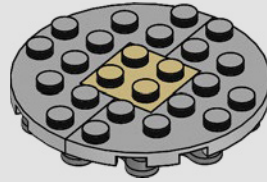

3

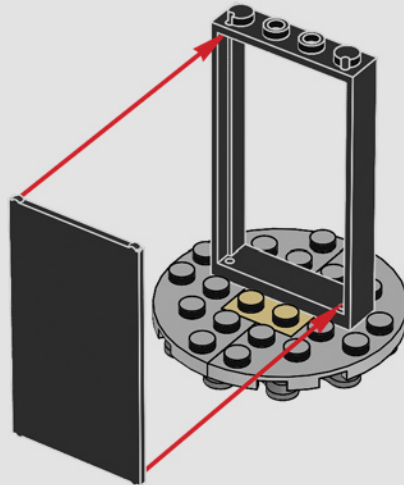

4

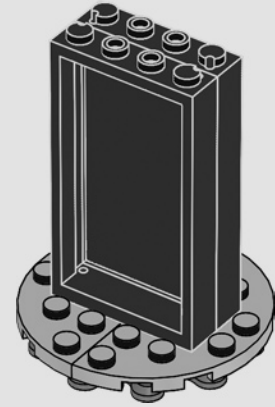

5

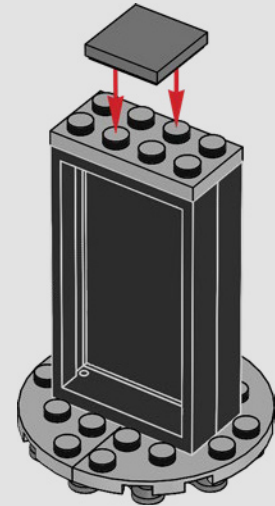

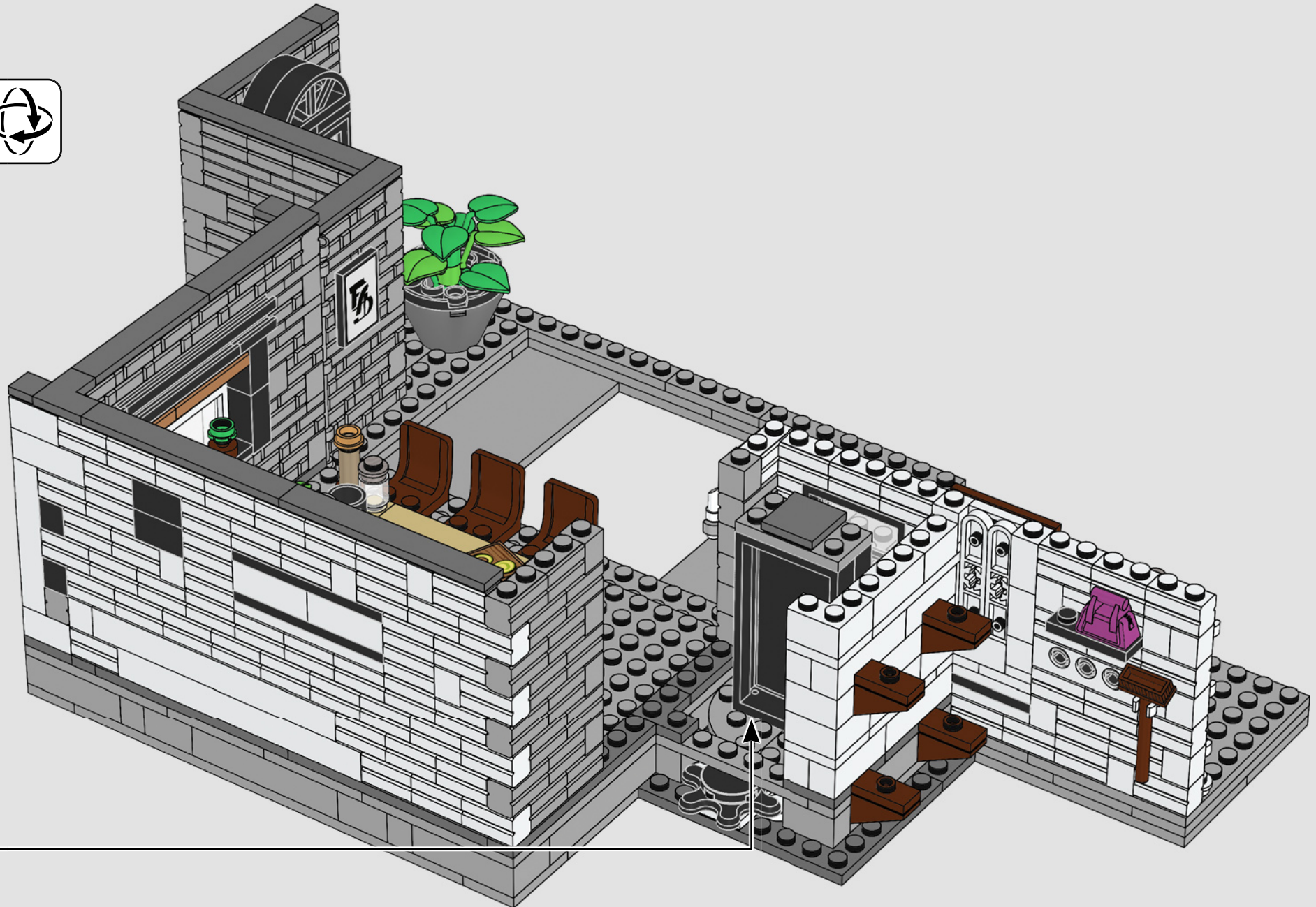

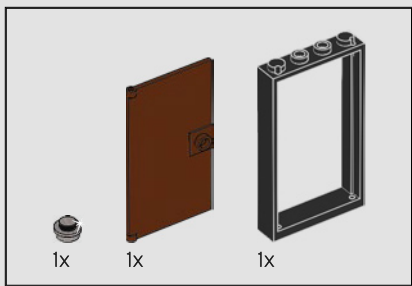

121

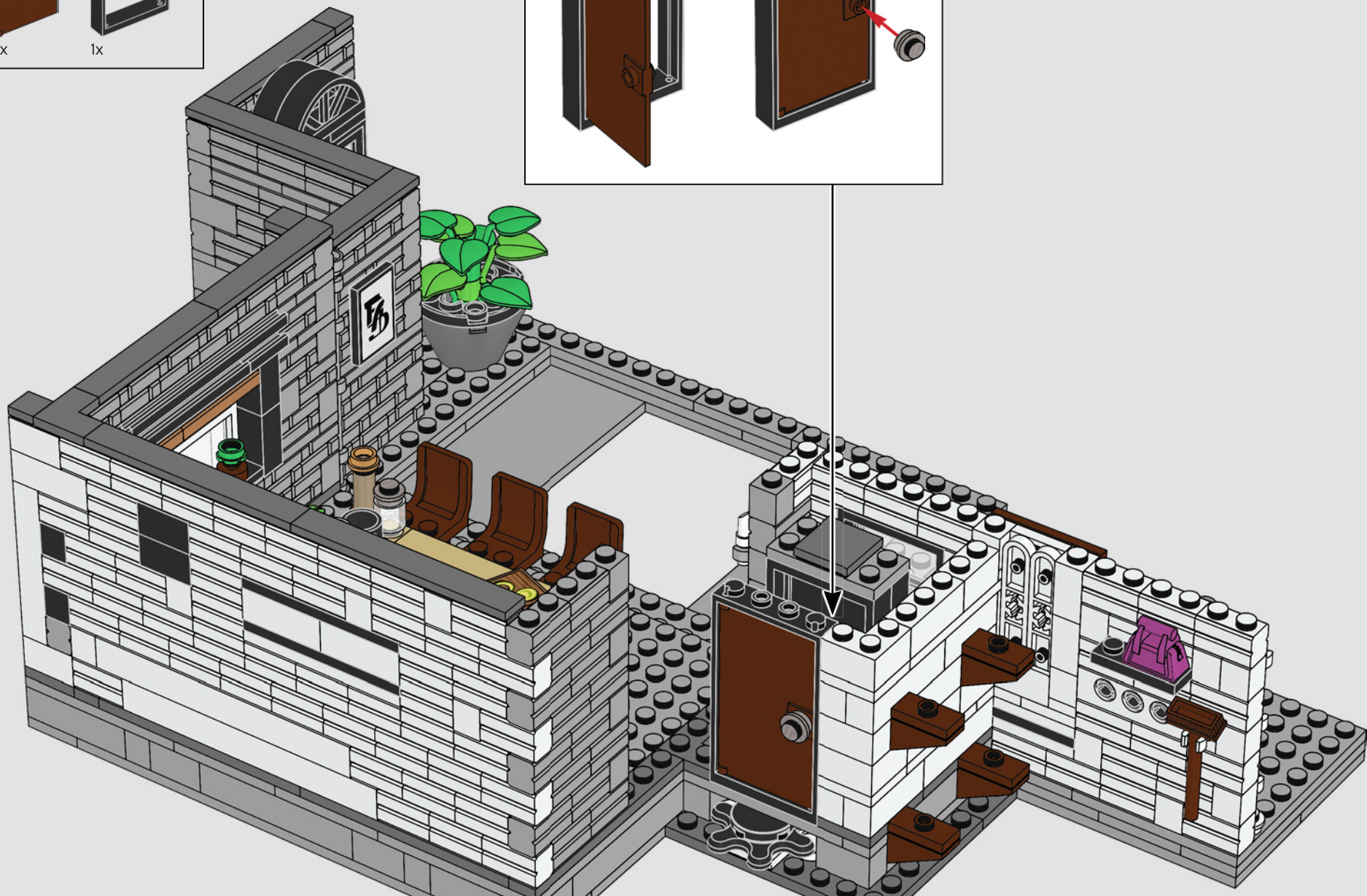
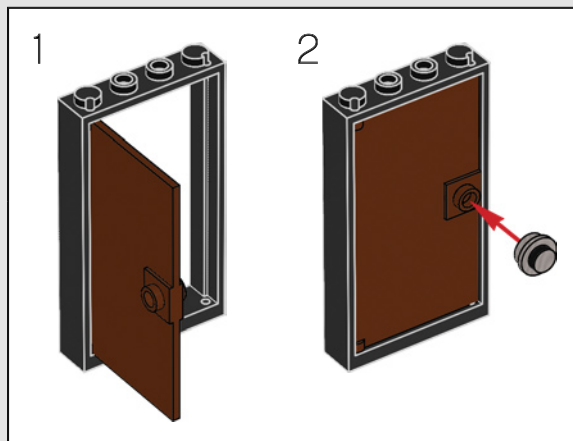



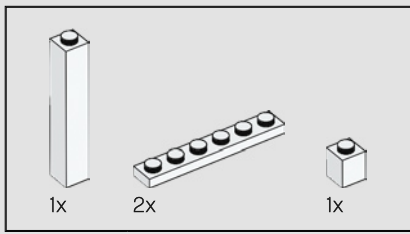

122

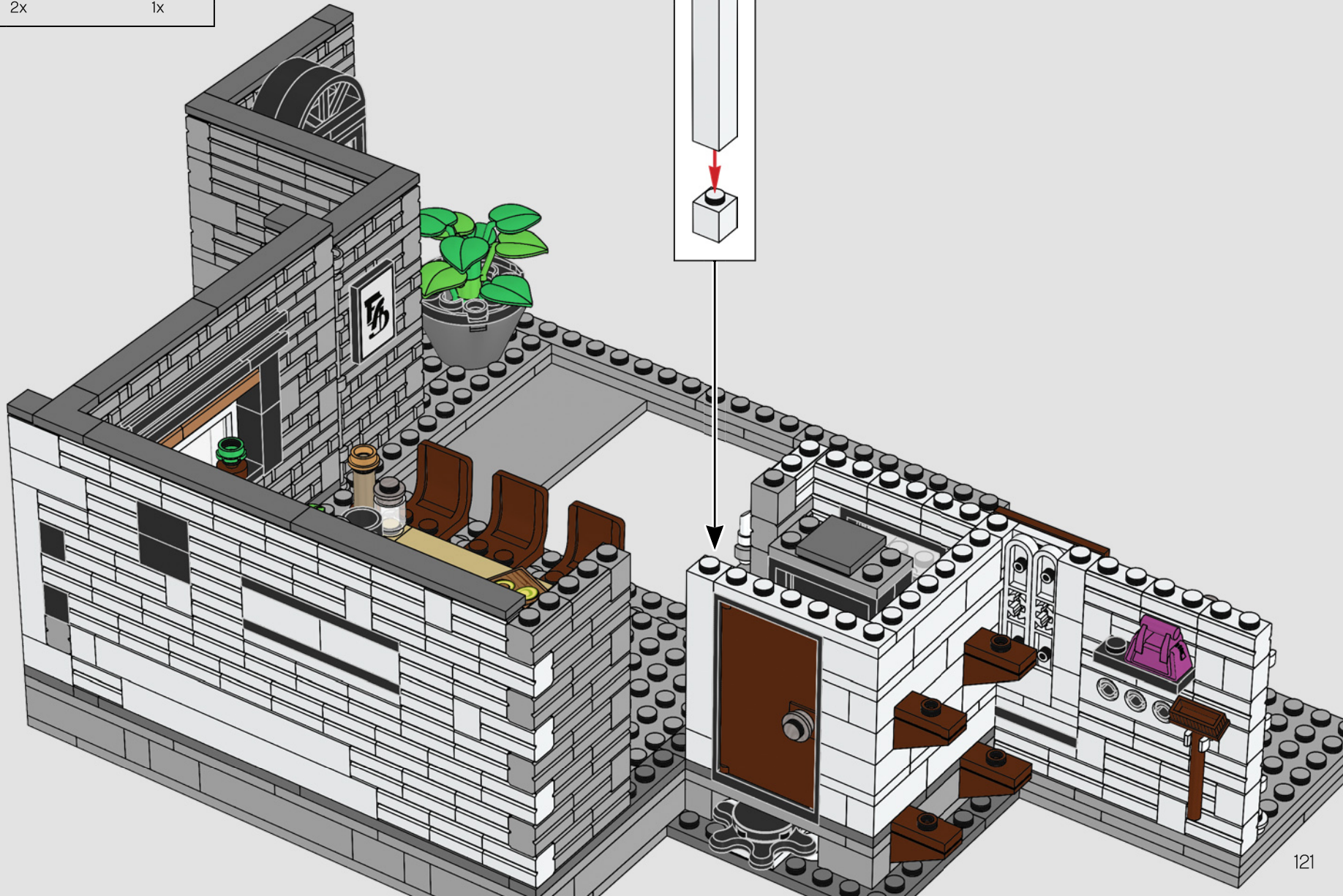

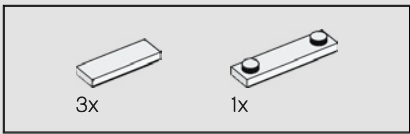

123

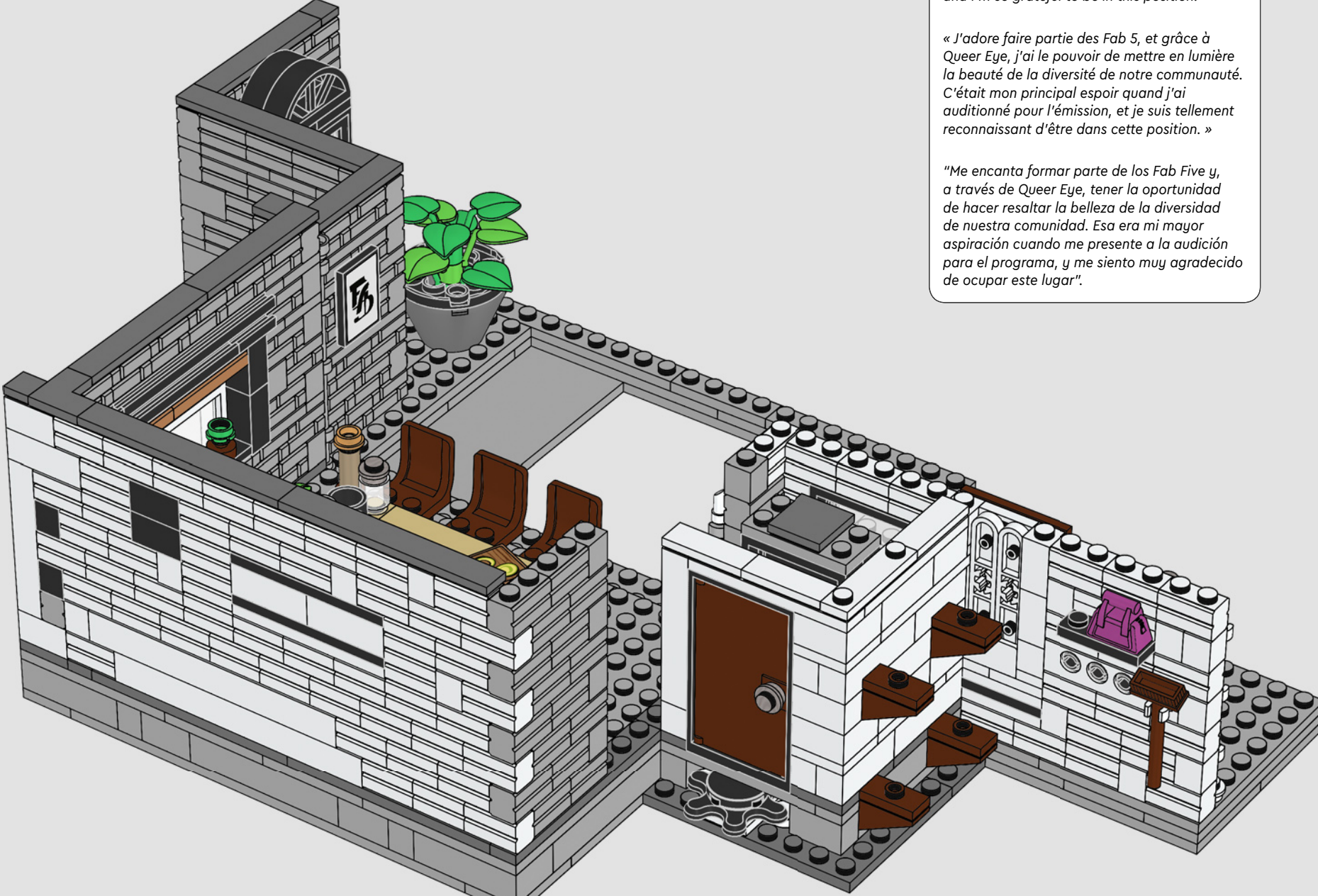

Tan France

"I love being a part of the Fab 5, and through Queer Eye, I get to shed light on the beauty of the diversity of our community. That was my main hope, when I auditioned for the show, and I'm so grateful to be in this position."

« J'adore faire partie des Fab 5, et grâce à Queer Eye, j'ai le pouvoir de mettre en lumière la beauté de la diversité de notre communauté. C'était mon principal espoir quand j'ai auditionné pour l'émission, et je suis tellement reconnaissant d'être dans cette position. »

"Me encanta formar parte de los Fab Five y, a través de Queer Eye, tener la oportunidad de hacer resaltar la belleza de la diversidad de nuestra comunidad. Esa era mi mayor aspiración cuando me presente a la audición para el programa, y me siento muy agradecido de ocupar este lugar".

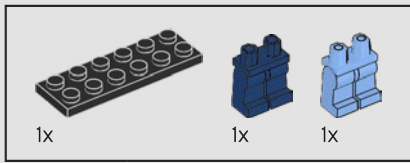

124

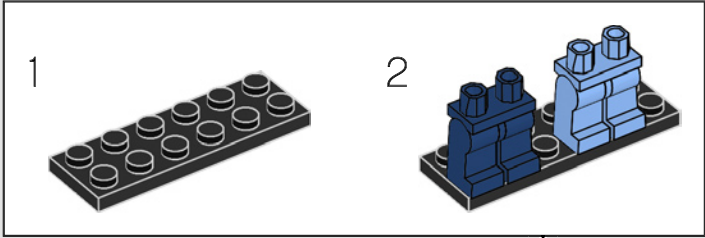
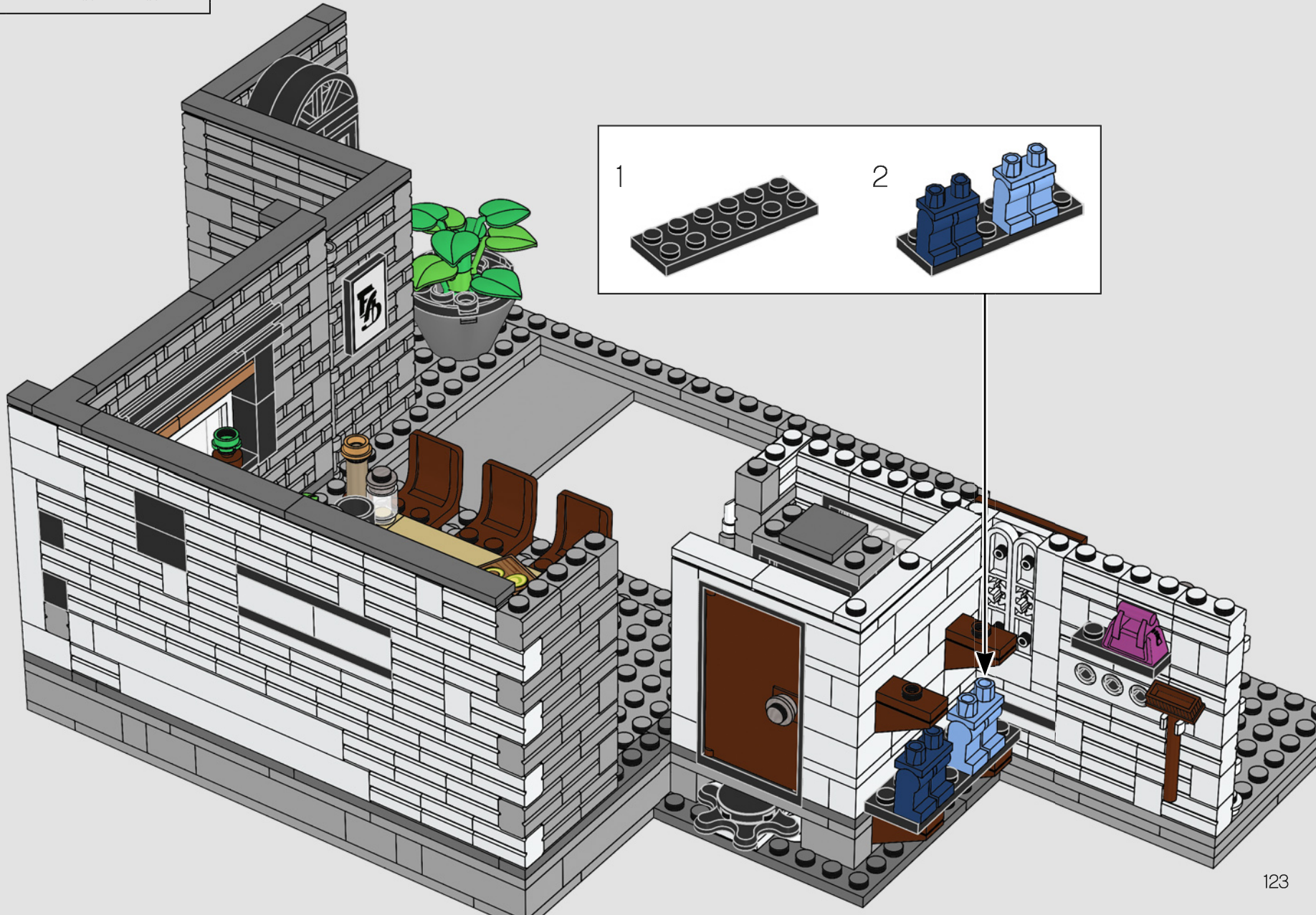

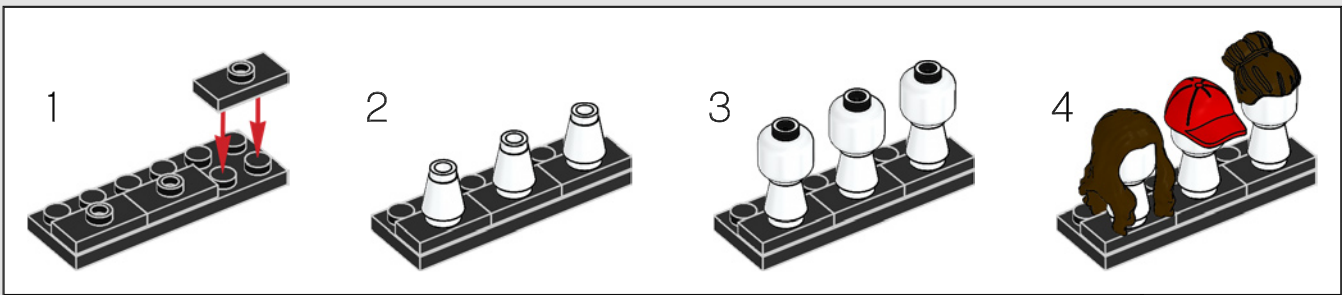
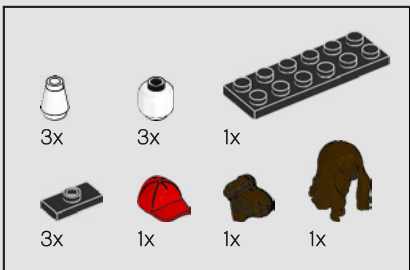

125



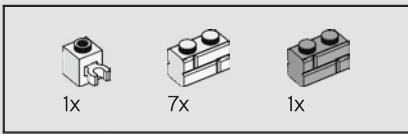

126



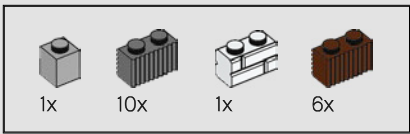

127

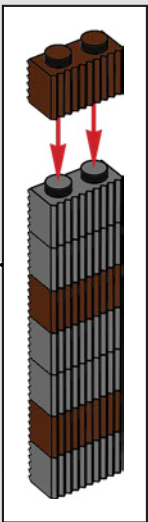
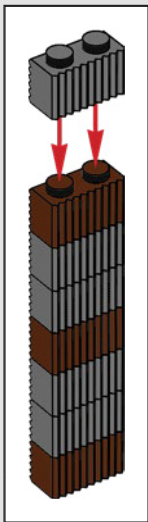

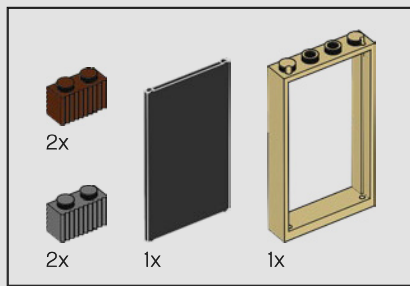

128

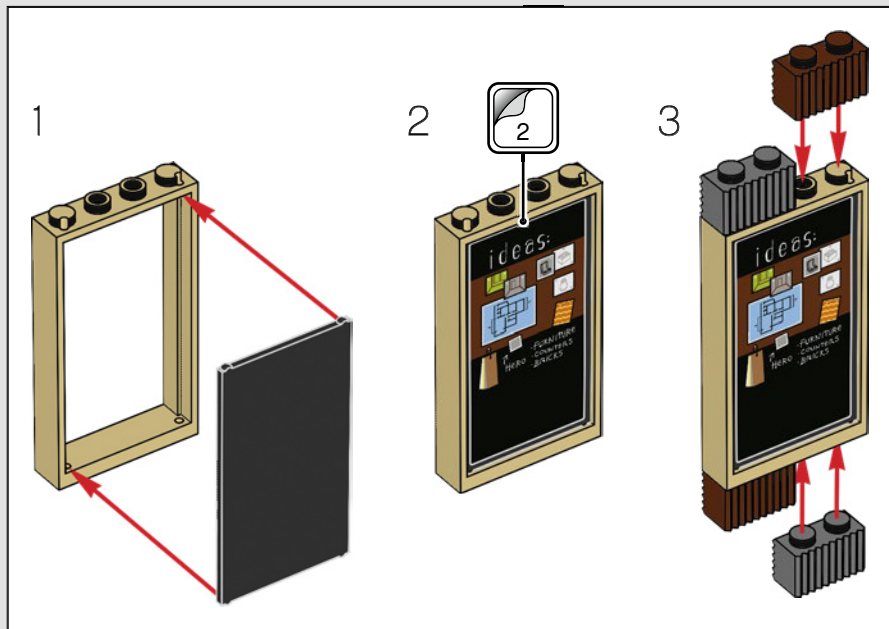

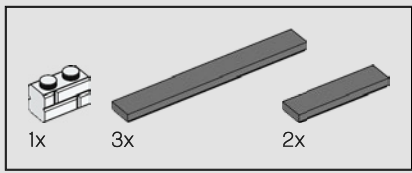

129

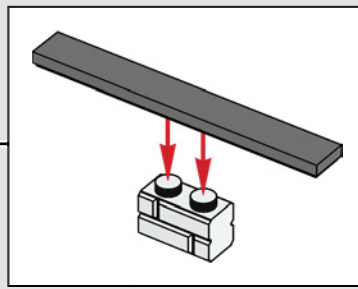



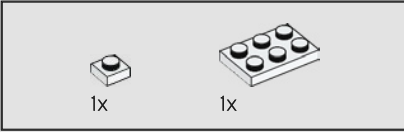
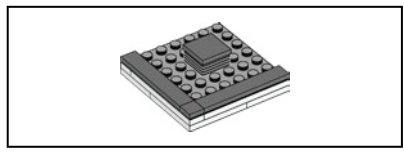

130

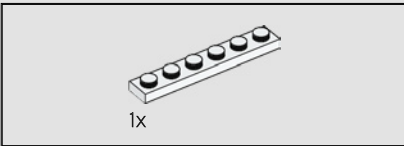
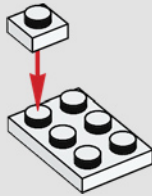

131

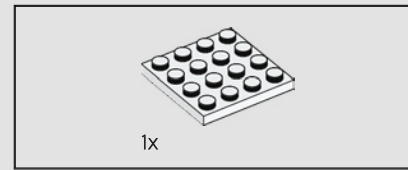
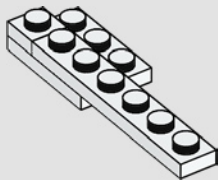

132

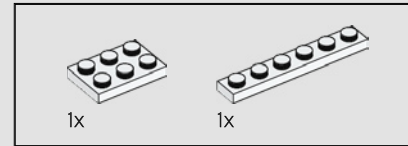
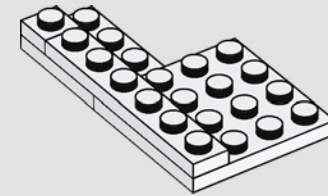

133

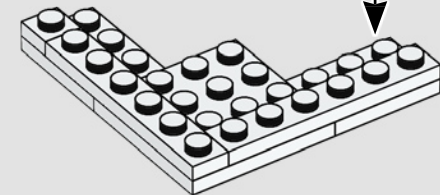
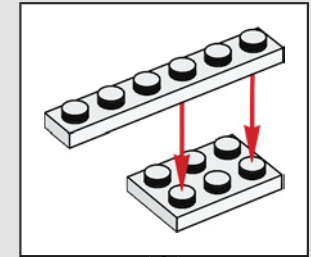

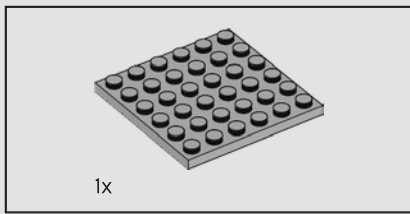

134

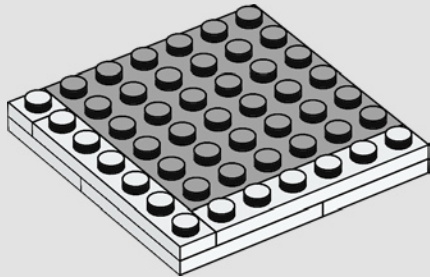

135

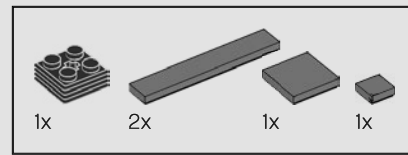
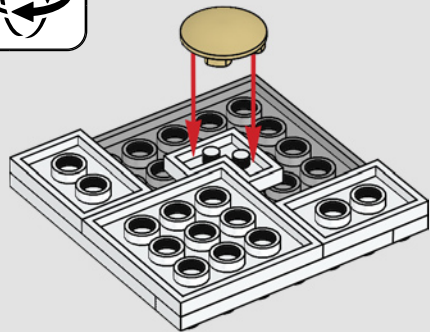

136

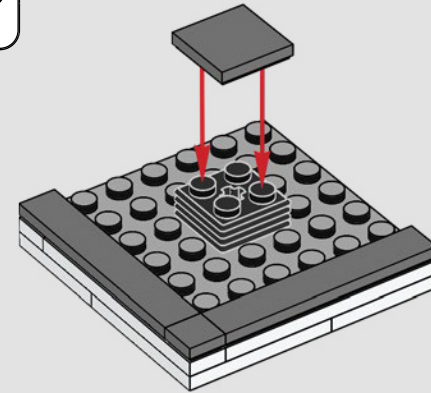
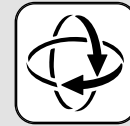

Tan France

*"That transformation chamber is genius! One twist and 'Ta-daaa!' the big reveal!"*

*« Cette salle de transformation est géniale ! Une rotation et "tadam !", c'est le grand dévoilement ! »*

*"¡La cámara de transformación es maravillosa! Un giro y, ¡sorpresa!, la gran revelación".*

137



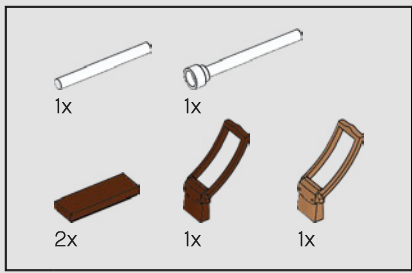

138



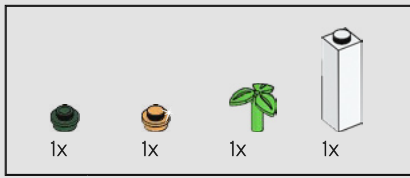

139

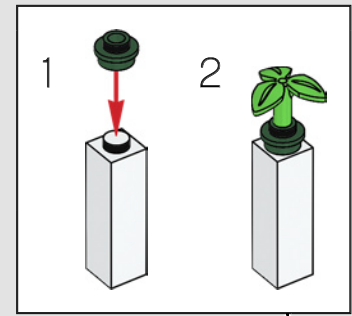



140

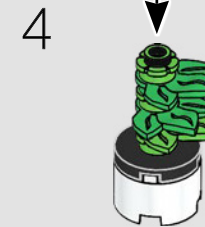
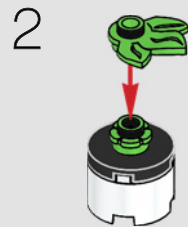
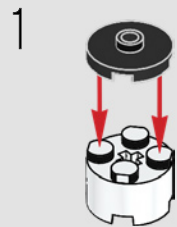

2x



Karamo Brown

"As an adult, any creative process can help give you focus and take you out of your own head space. Building with LEGO® is a perfect way to help you unwind and de-stress while also giving you a real sense of accomplishment with whatever you create. So just like our show, LEGO can help in a little way to piece together people's lives. This is the perfect partnership."

« Lorsque vous êtes adulte, tout processus créatif peut vous aider à vous concentrer et à vous changer les idées. Construire avec LEGO® est un moyen idéal de vous détendre et de décompresser tout en vous donnant un réel sentiment d'accomplissement grâce à vos créations. Ainsi, tout comme notre émission, LEGO peut aider les gens à reconstruire leur vie. C'est le partenariat parfait. »

"En tu vida adulta, cualquier proceso creativo puede ayudarte a concentrar tu atención y despejar tu mente. Además de ser una excelente manera de relajarte y desestresarte, construir con LEGO® te brinda una verdadera sensación de logro al terminar alguna creación. Igual que nuestro programa, LEGO puede poner un granito de arena para conectar las piezas de las vidas de las personas. Eso hace perfecta esta alianza".





Bobby Berk

"I'm so happy with the finished set. I think we have really managed to capture the essence of everything in our original loft!"

« Je suis enchanté par l'ensemble fini. Je pense que nous avons vraiment réussi à capturer l'essence de notre loft original ! »

"Me llena de satisfacción ver la versión final del set. ¡Creo que realmente pudimos capturar la esencia de todo lo que había en el loft original!"







# FEEDBACK AND WIN



## FEEDBACK AND WIN

Your feedback will help shape the future development of this product series.

Please visit:

## FEEDBACK UND GEWINNEN

Dein Feedback trägt zur Weiterentwicklung dieser Produktreihe bei.

Geh auf:

## COMMENTEZ ET GAGNEZ

Vos commentaires nous aideront à concevoir les futurs produits de cette gamme.

Rendez-vous sur :

## COMENTA Y GANA

Tu opinión nos ayudará a dar forma al desarrollo de esta serie de productos en el futuro.

Visita:

## 反馈有奖

您的反馈将有助于我们在今后改进本系列产品。

请访问：

[LEGO.com/productfeedback](https://www.lego.com/productfeedback)

By completing, you will automatically enter a drawing to win a LEGO® set.

Terms & Conditions apply.

Durch Ausfüllen nimmst du automatisch an der Verlosung eines LEGO® Preises teil.

Es gelten die Teilnahmebedingungen.

En envoyant vos commentaires, vous serez automatiquement inscrit(e) à un tirage au sort qui vous permettra de remporter un prix LEGO®.

Offre soumise à conditions.

Al contestar, participarás automáticamente en el sorteo y podrás ganar un set LEGO®.

Sujeto a Términos y Condiciones.

完成我们的反馈调查，即可自动进入抽奖环节，赢取乐高®套装。

适用《条款和条件》。

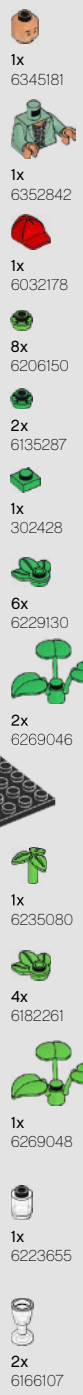



**Customer Service**  
**Kundenservice**  
**Service Consommateurs**  
**Servicio Al Consumidor**  
**LEGO.com/service or dial**



: 00800 5346 5555  
 : 1-800-422-5346



QUEER EYE