

BIONICLE®

TUTAMA



Ages/edades

8-16

8991

LEGO

1

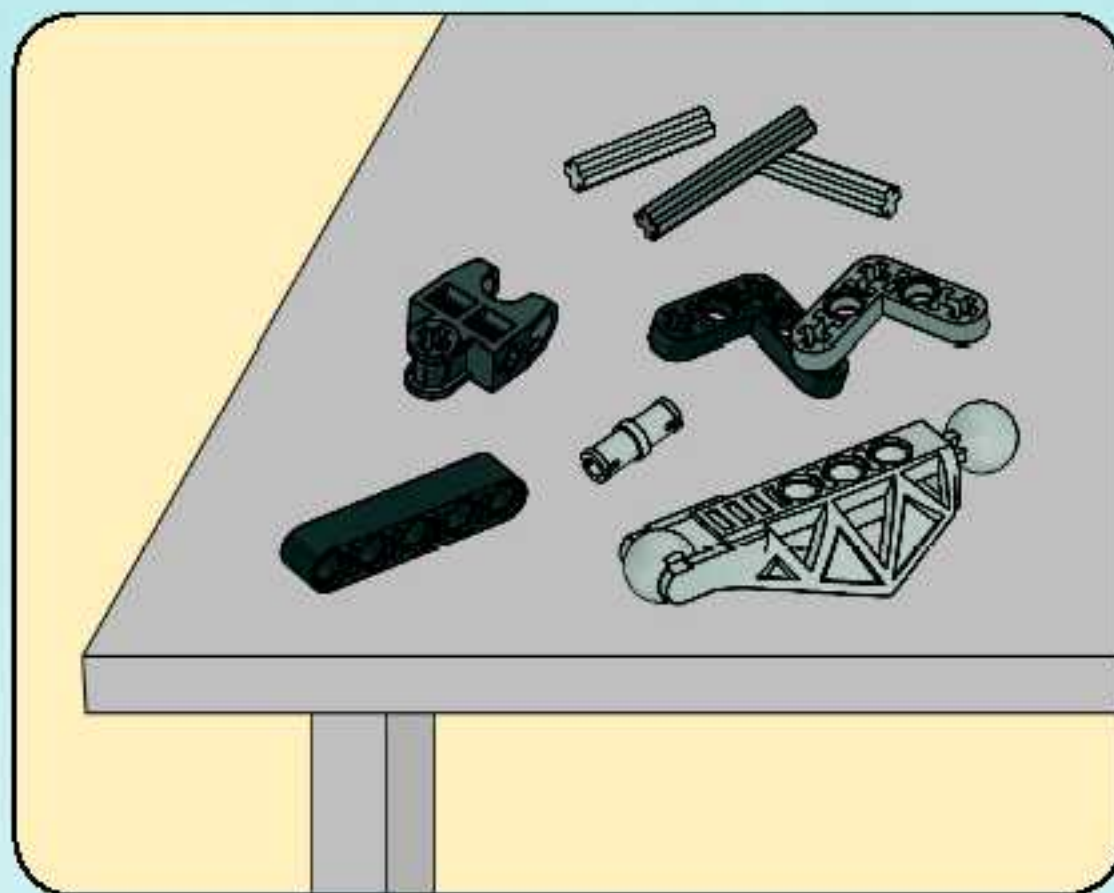

2

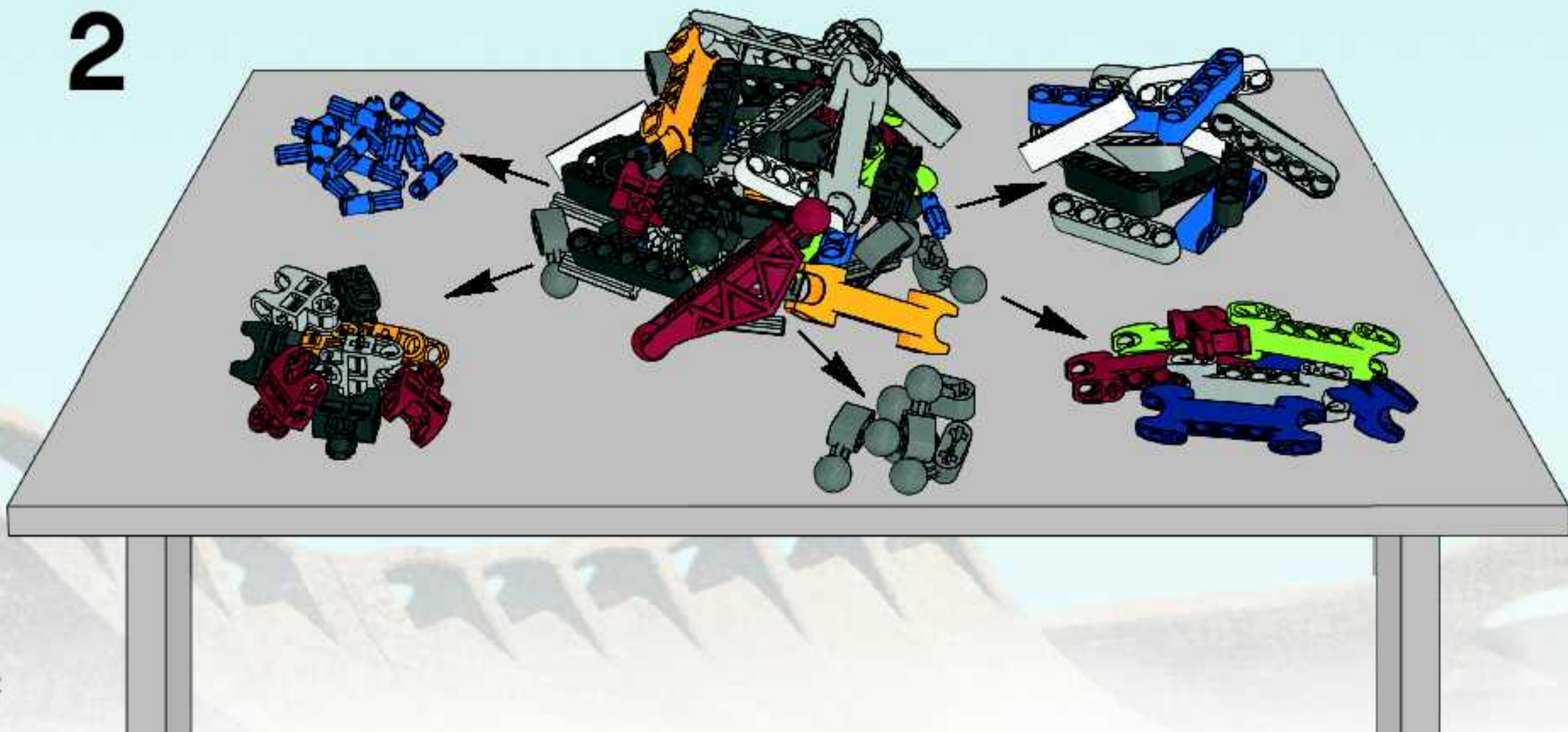

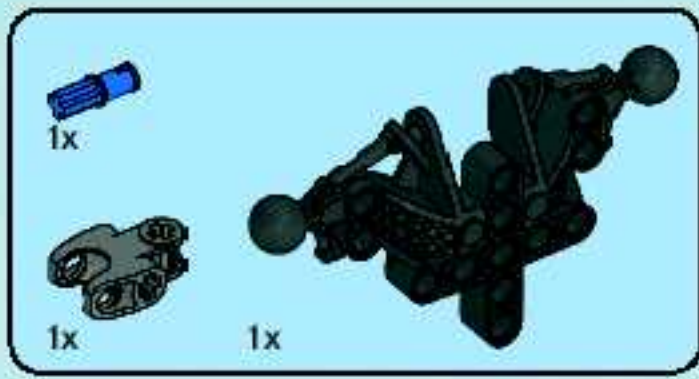

1

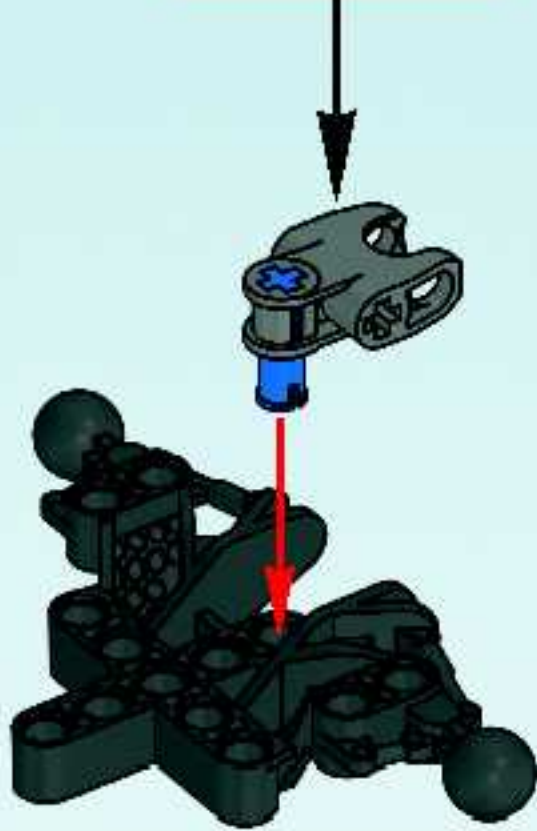
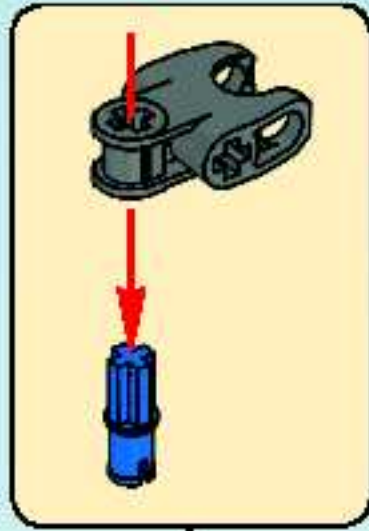

2

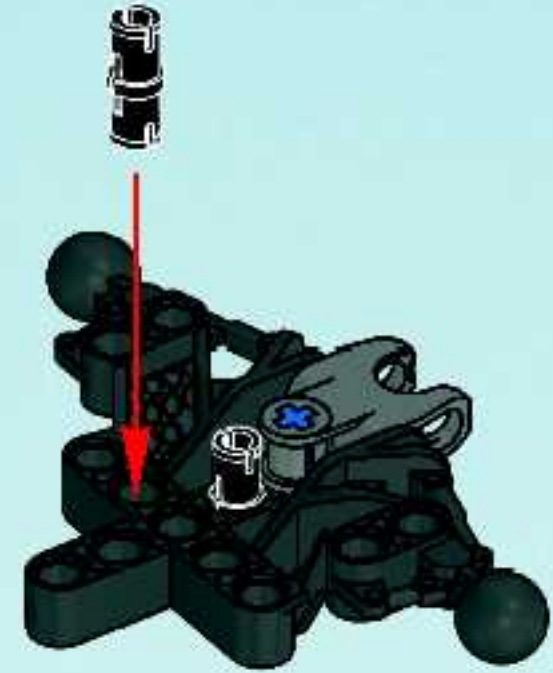

3

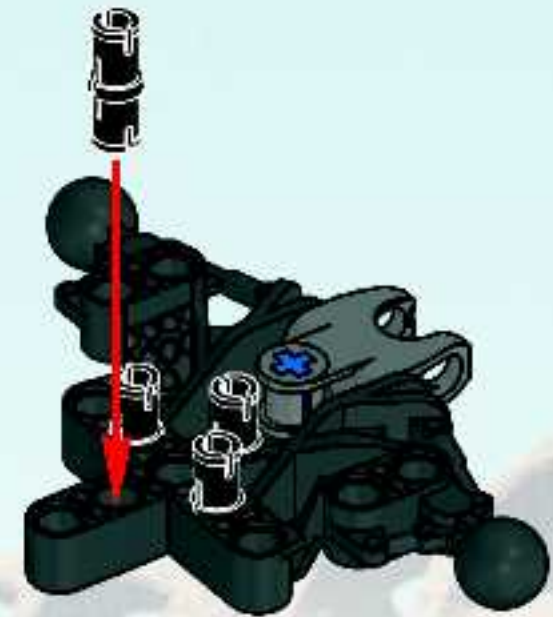

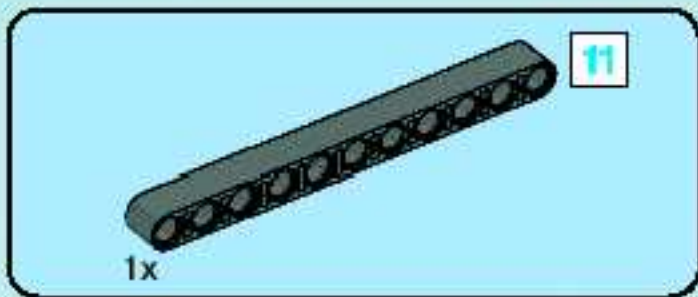

4

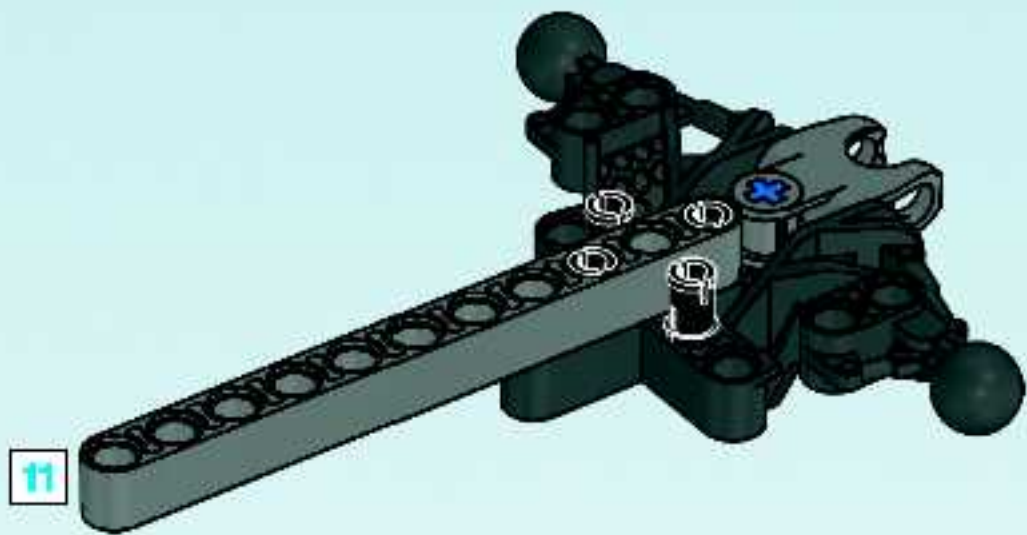

5

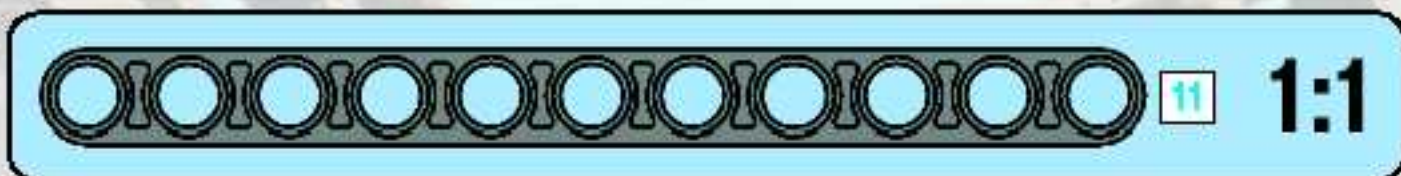
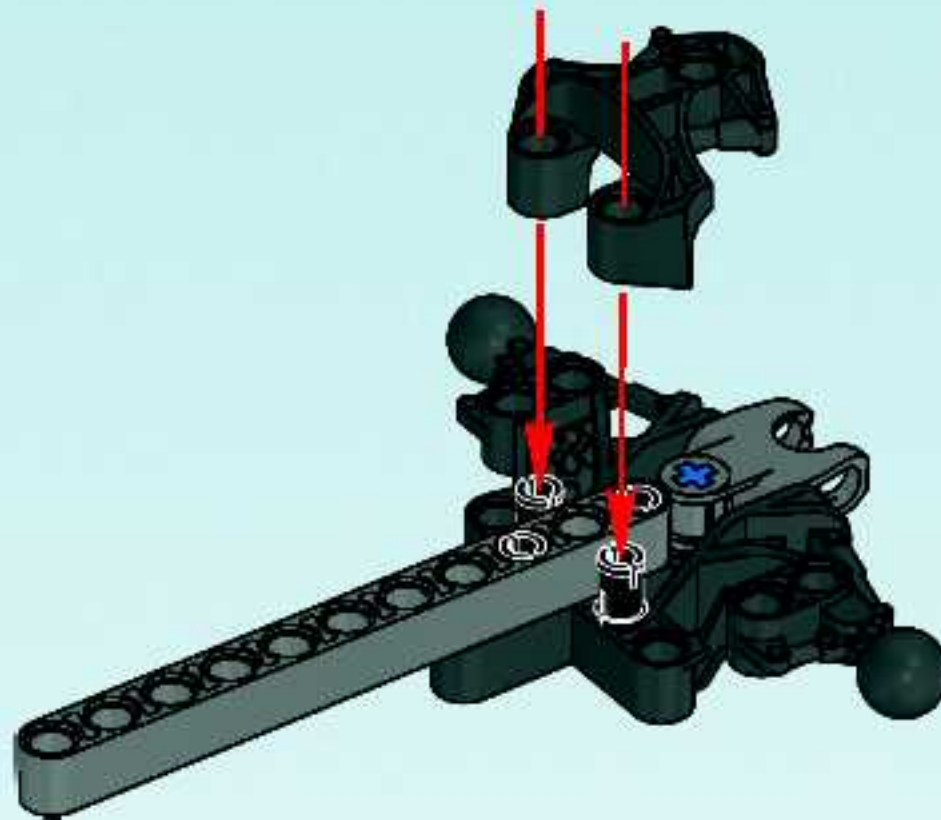



6

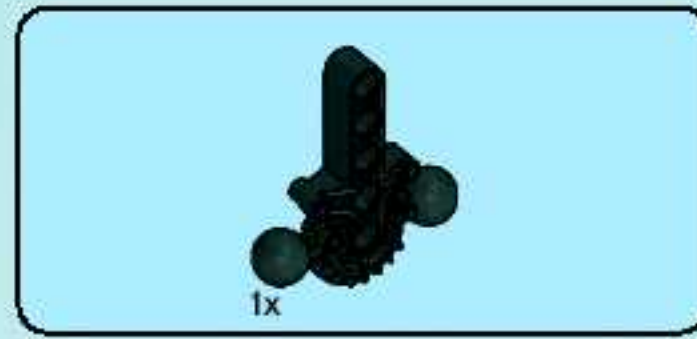
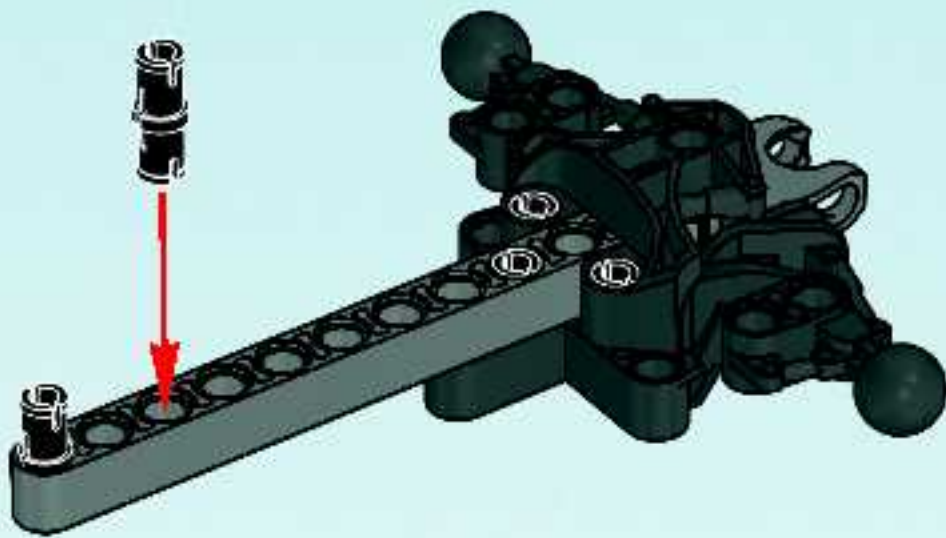

7

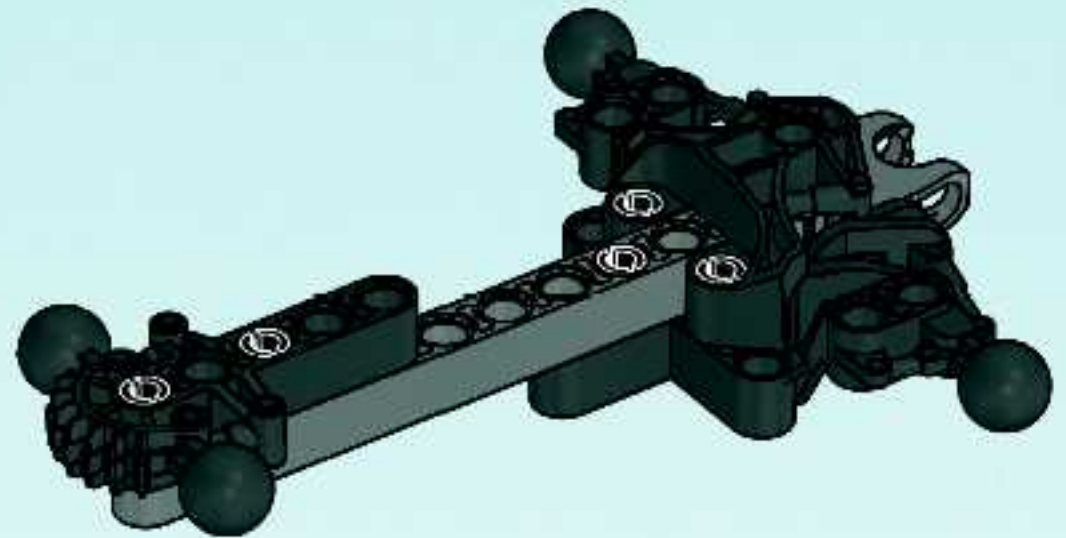

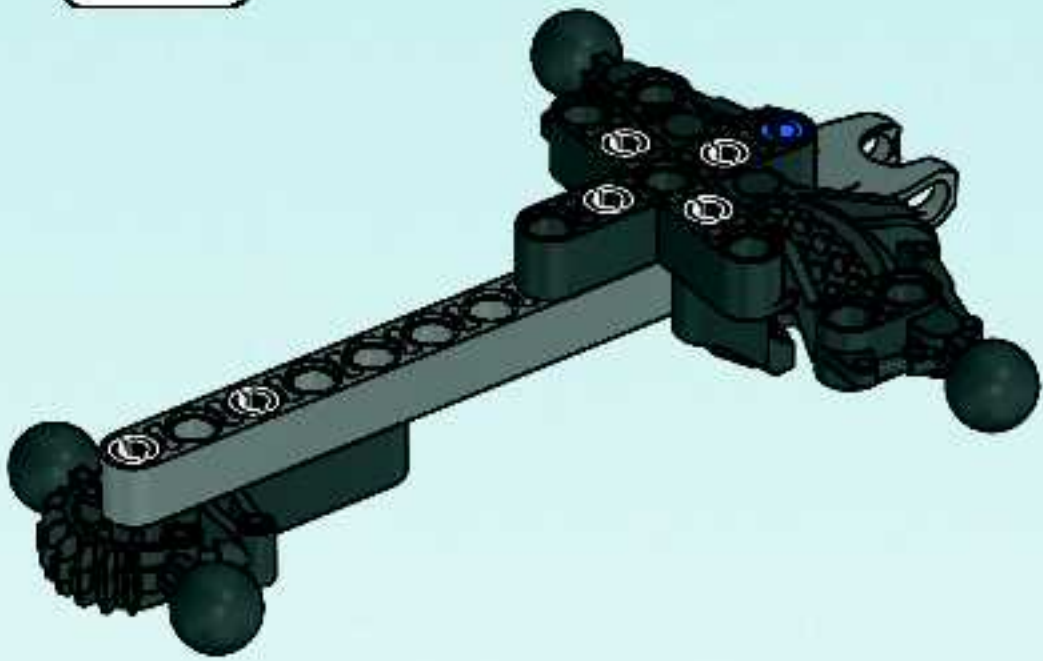

8

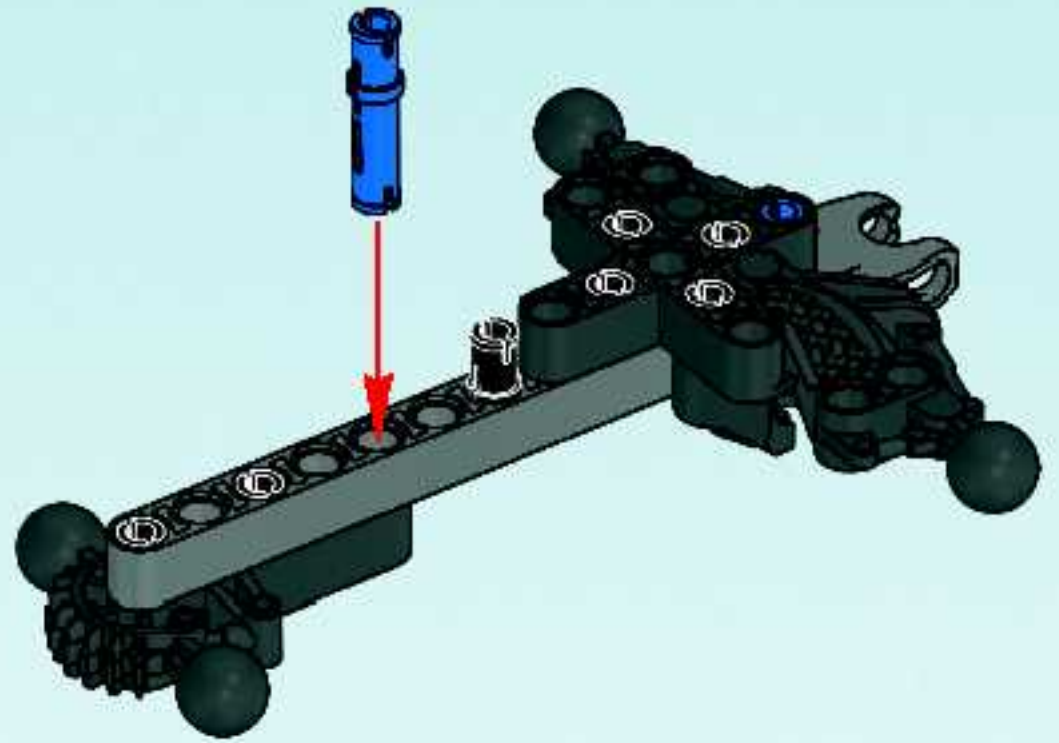

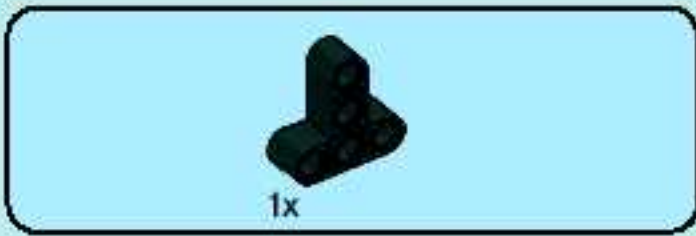

9

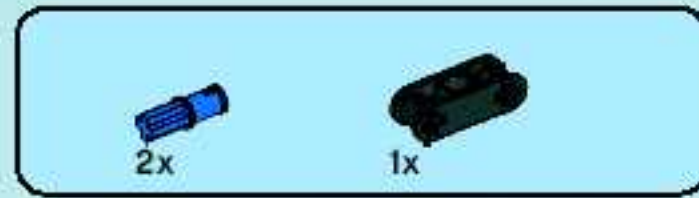
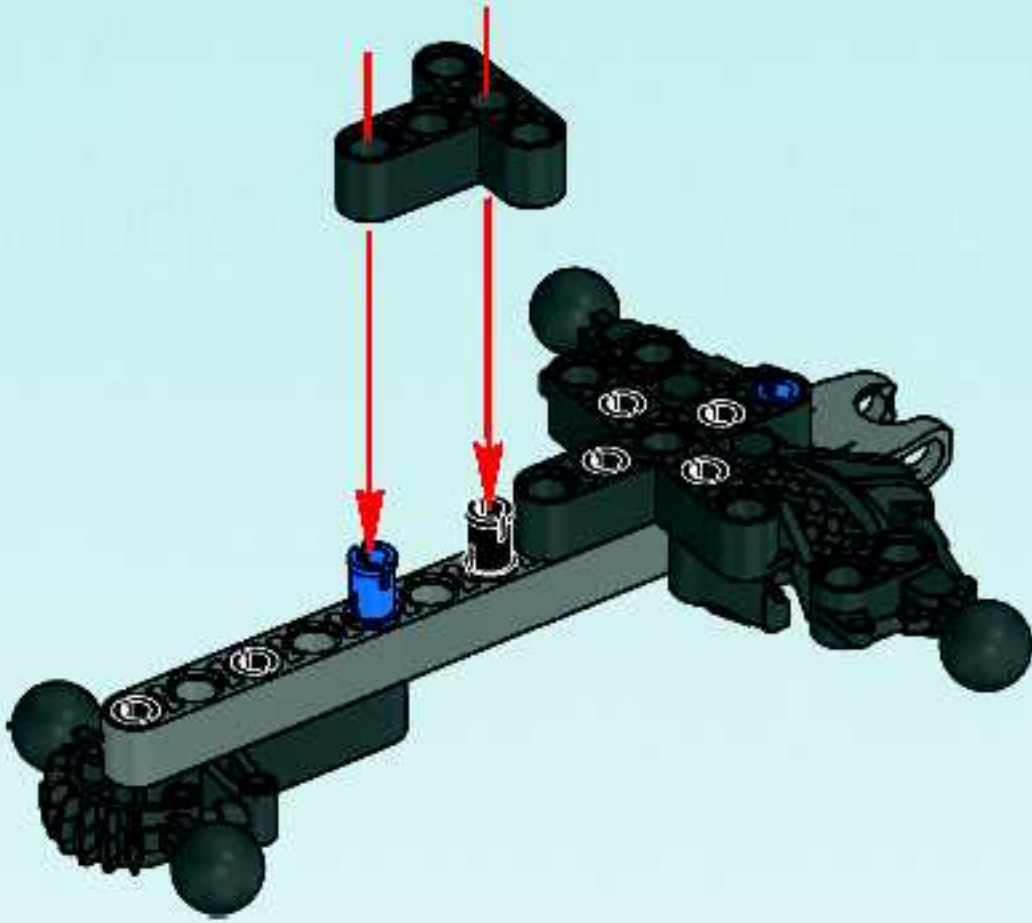

10

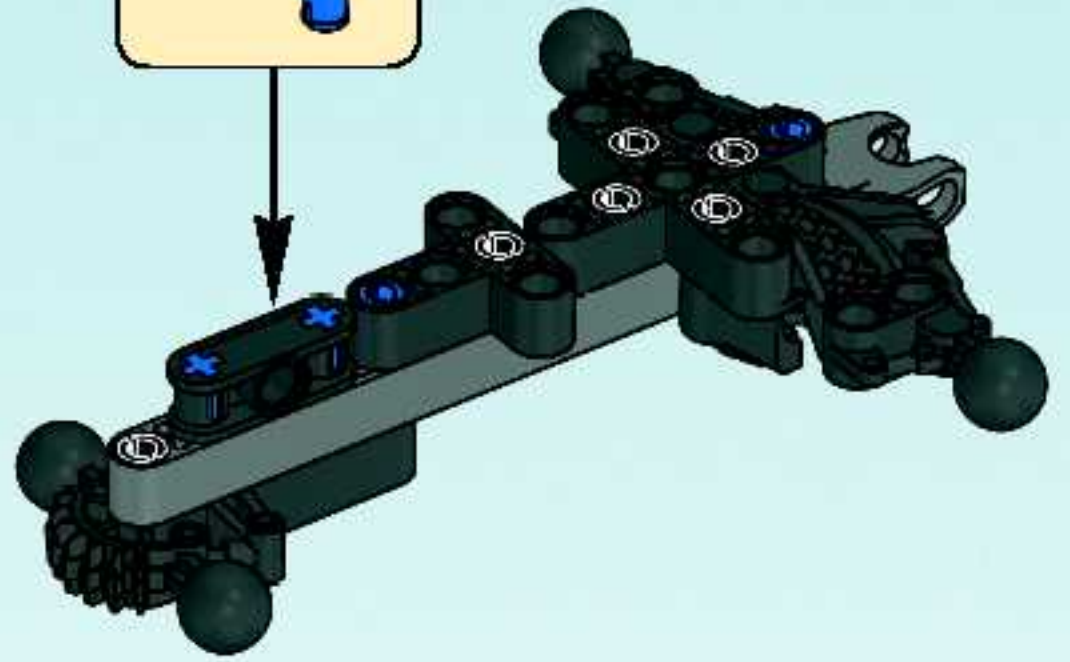
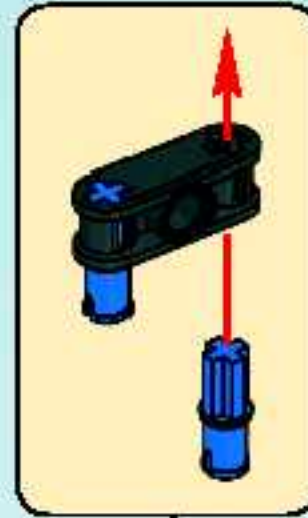

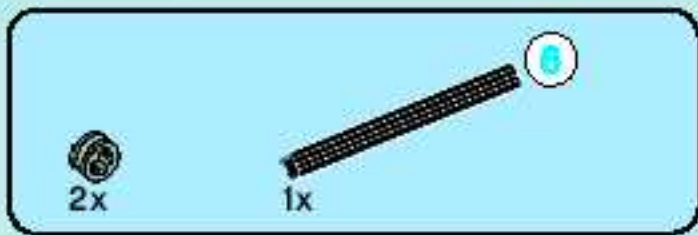

11

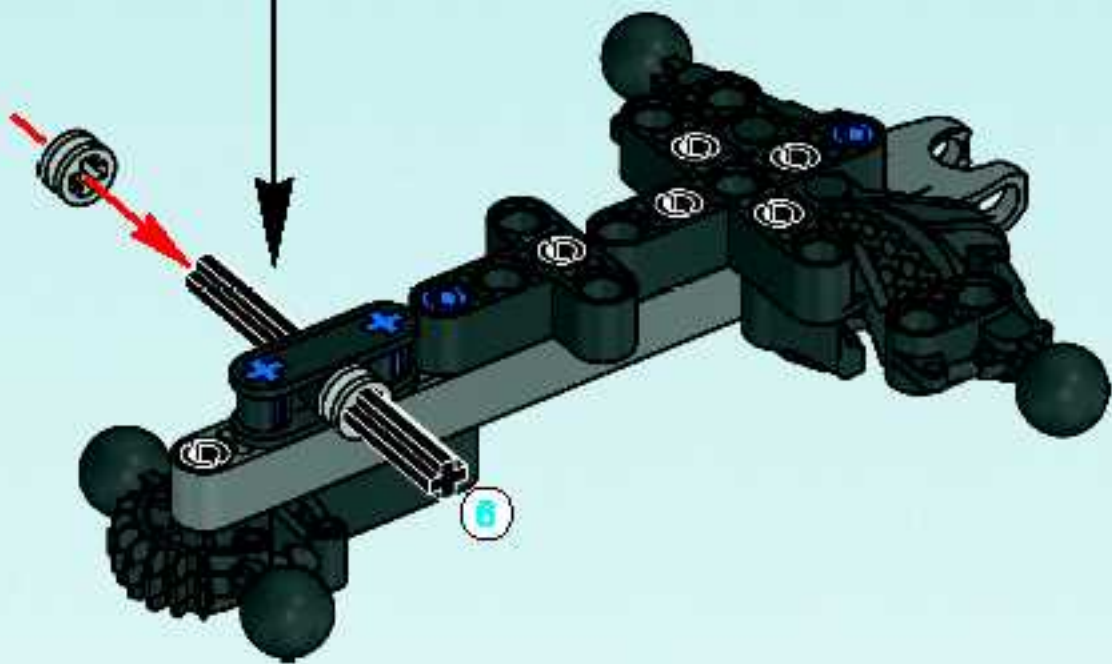
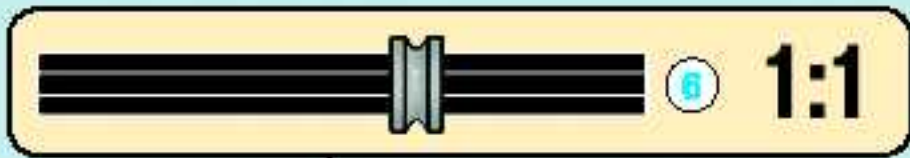

12

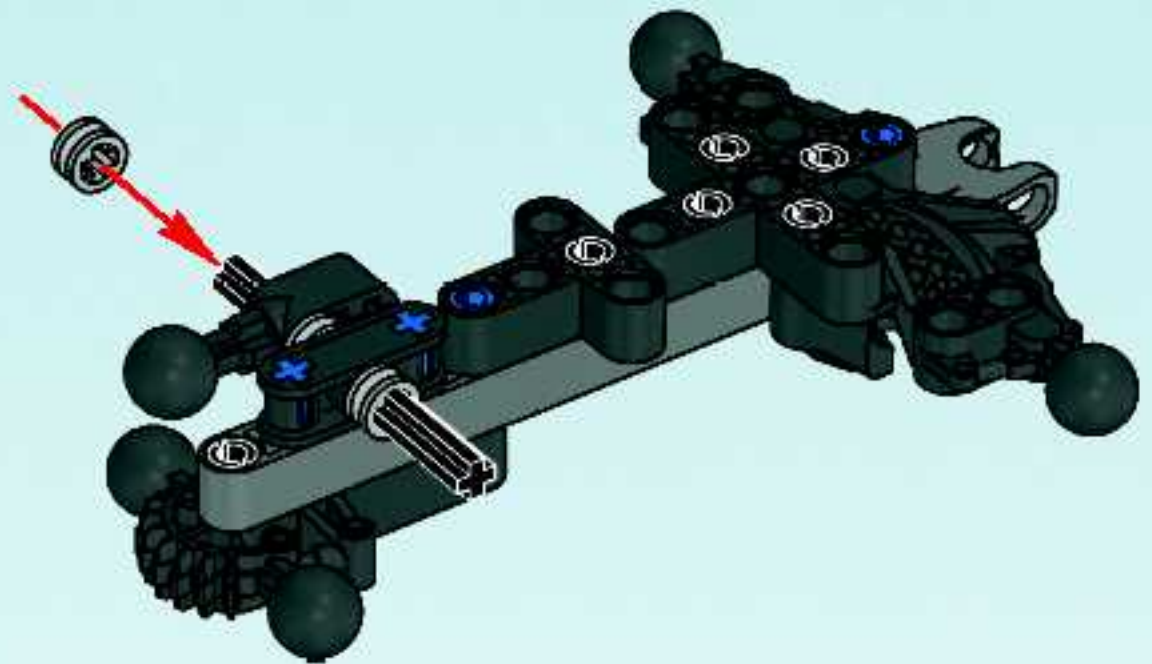

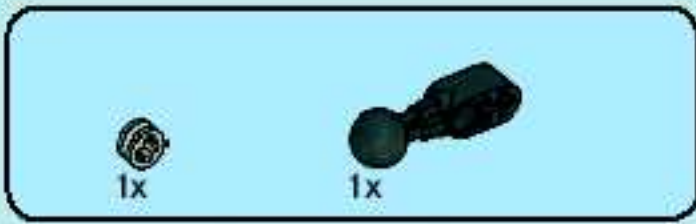

13

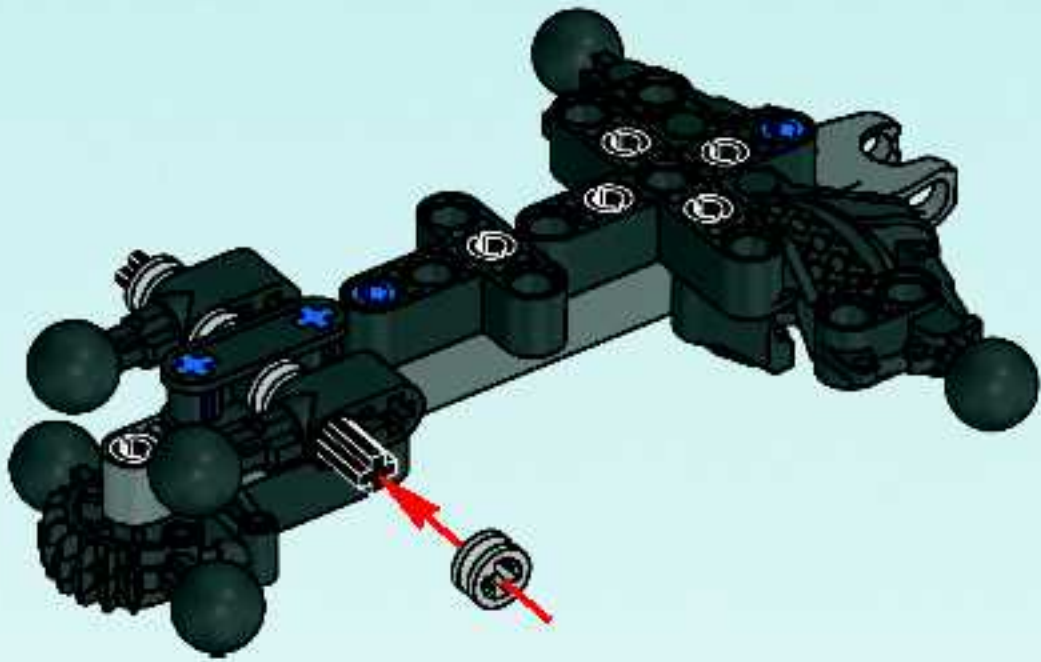

14

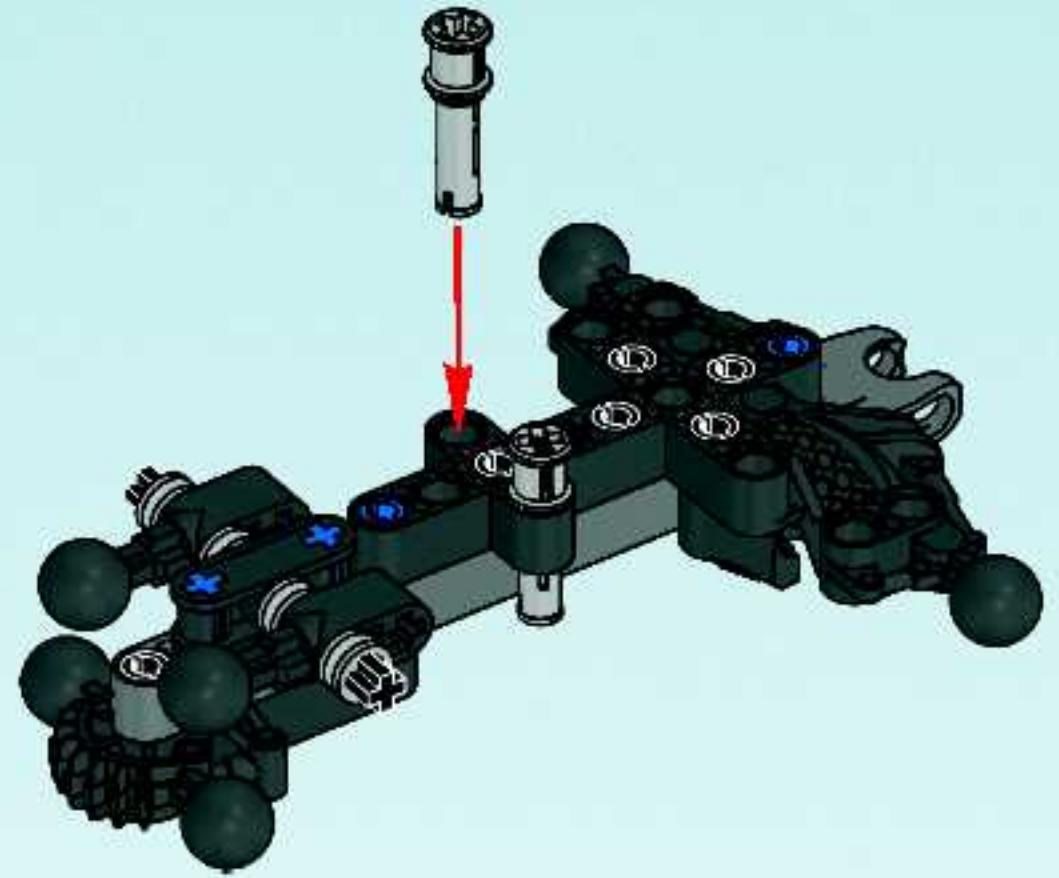

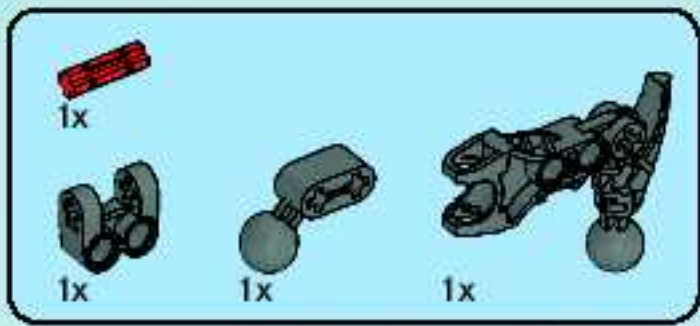

15

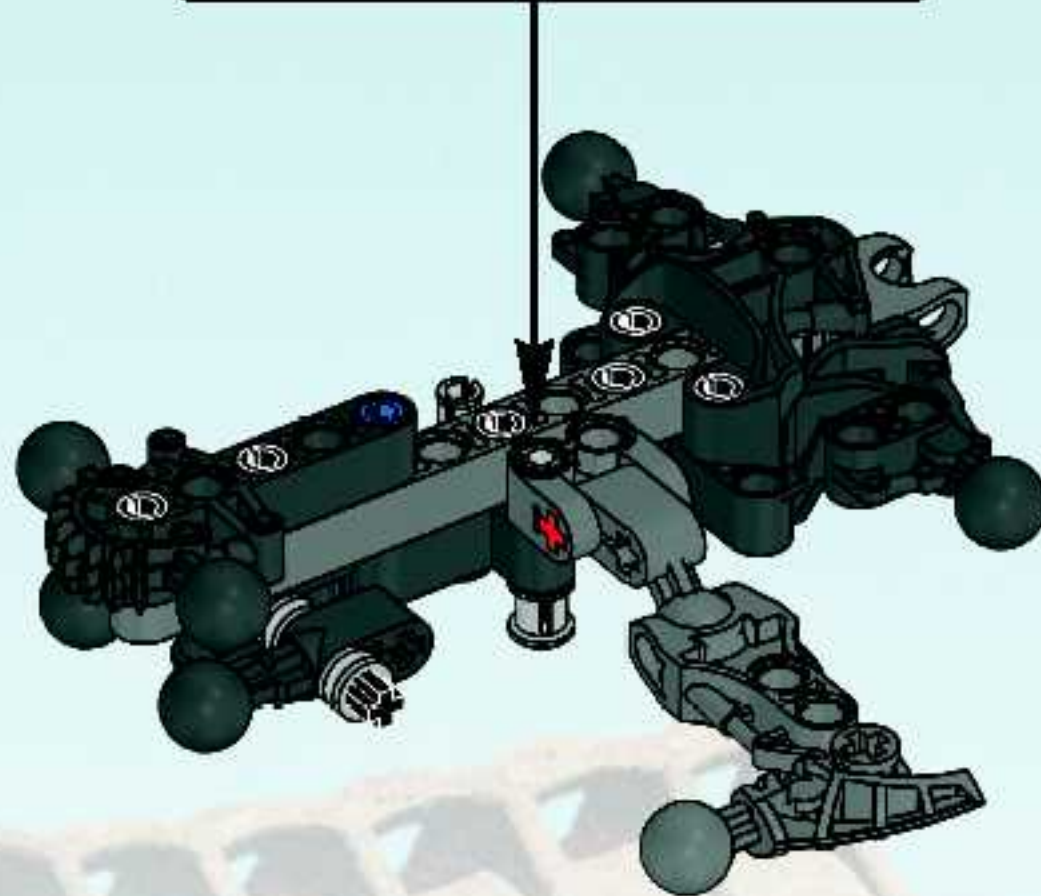
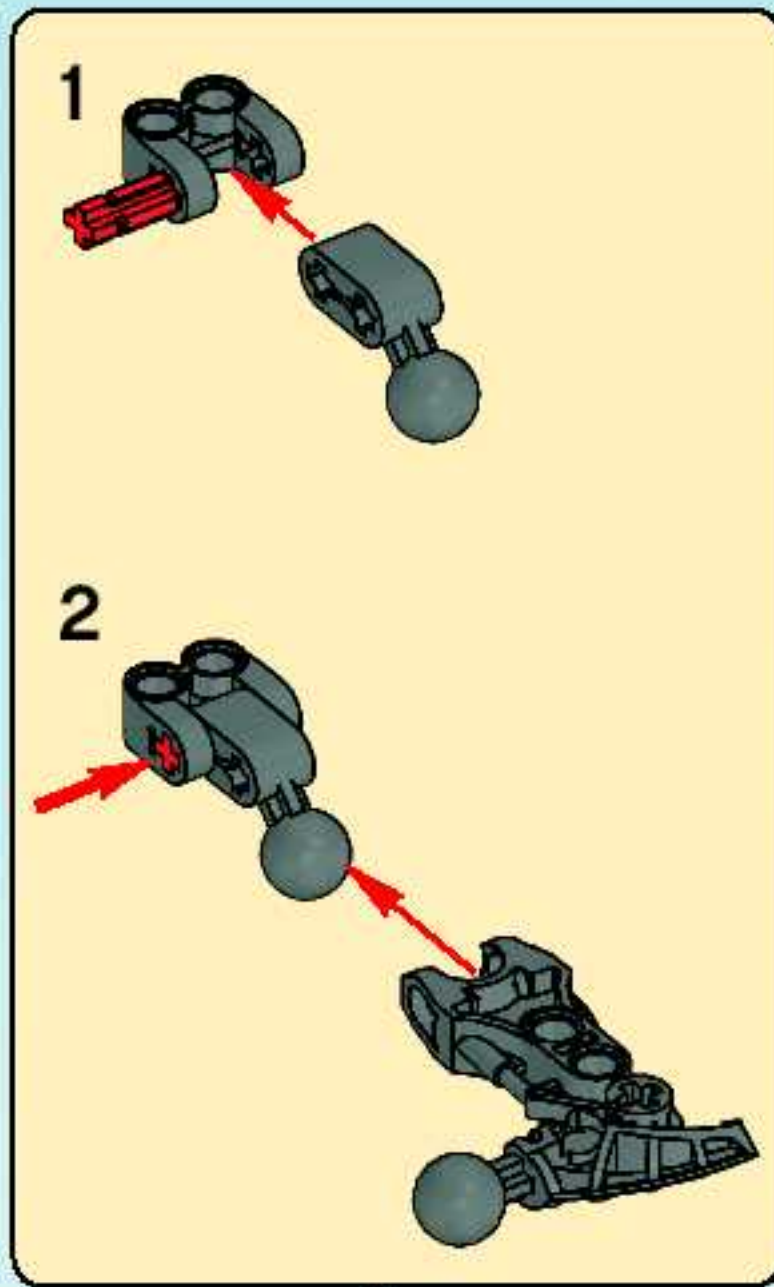

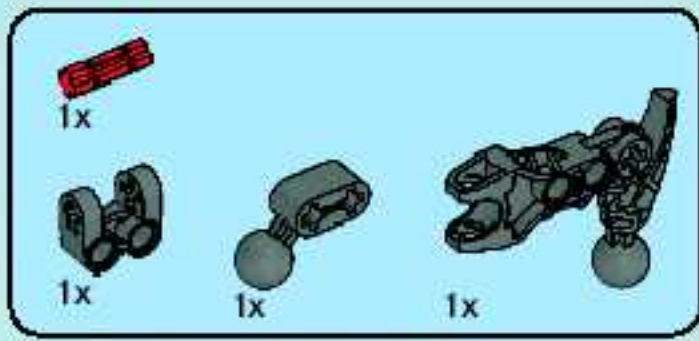

16

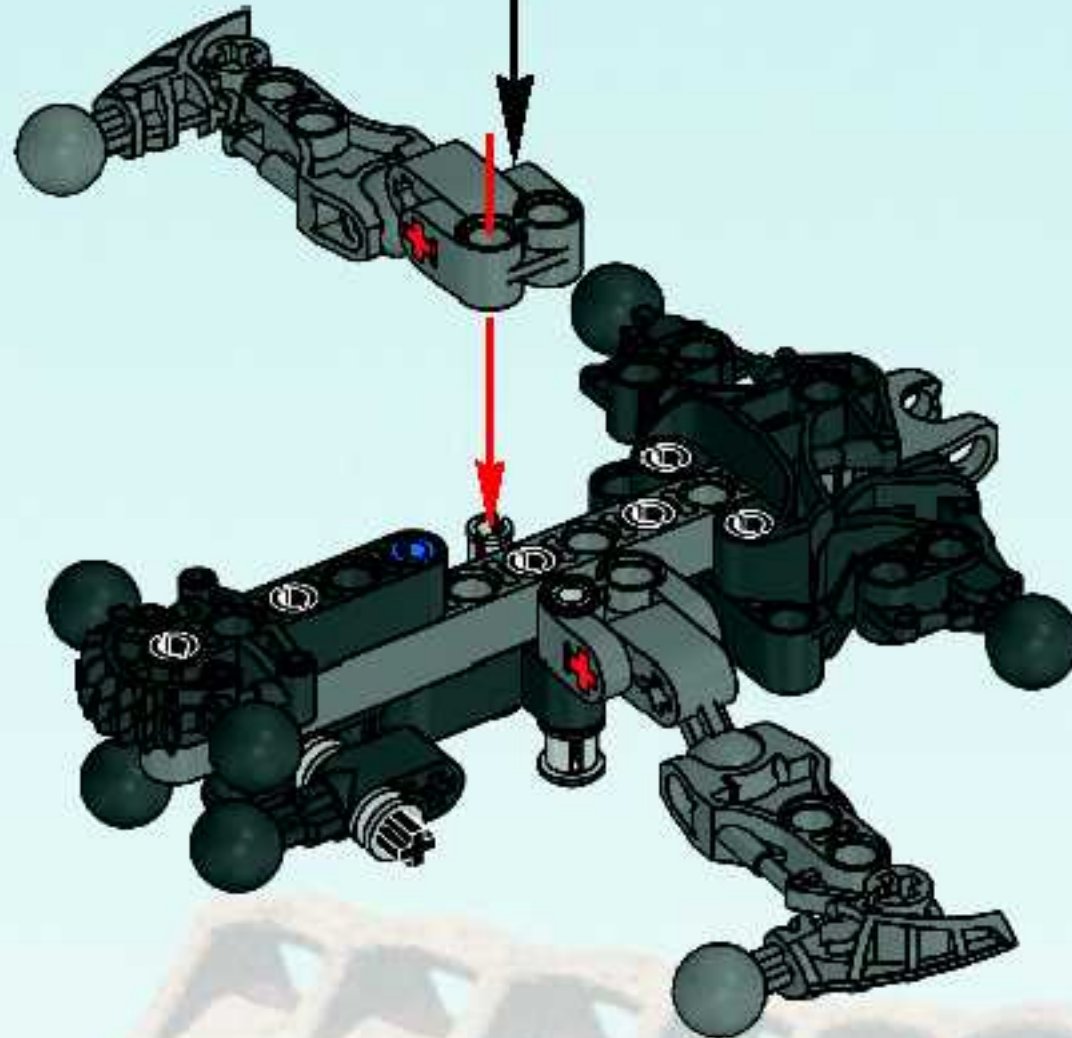
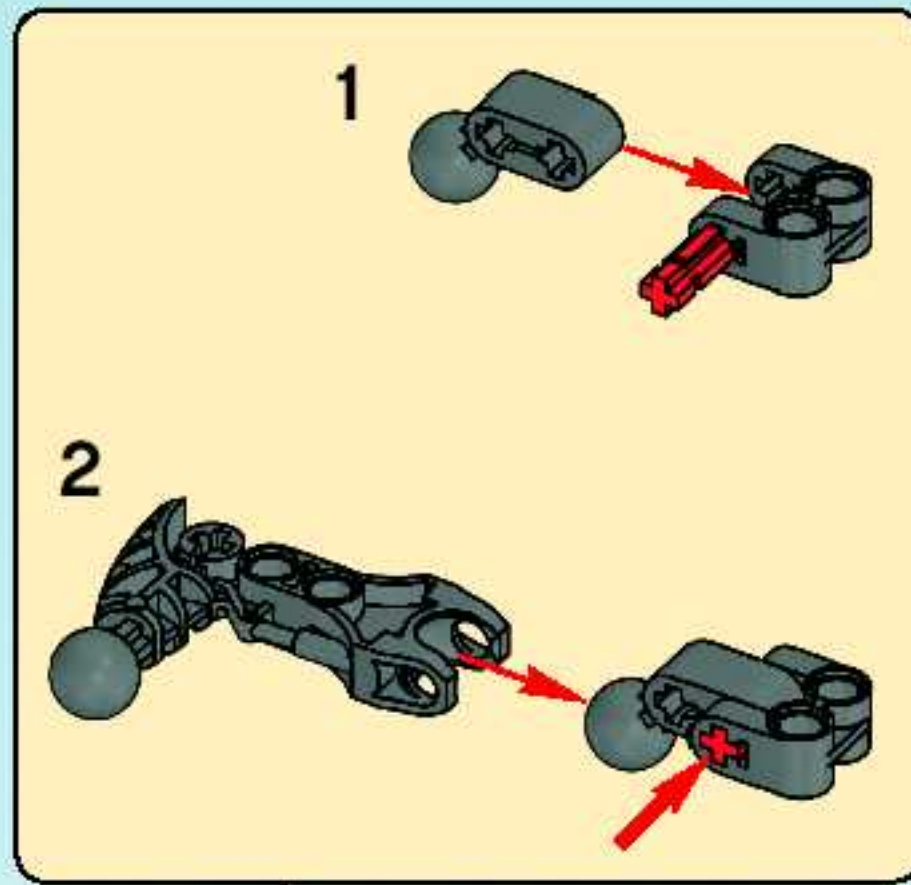

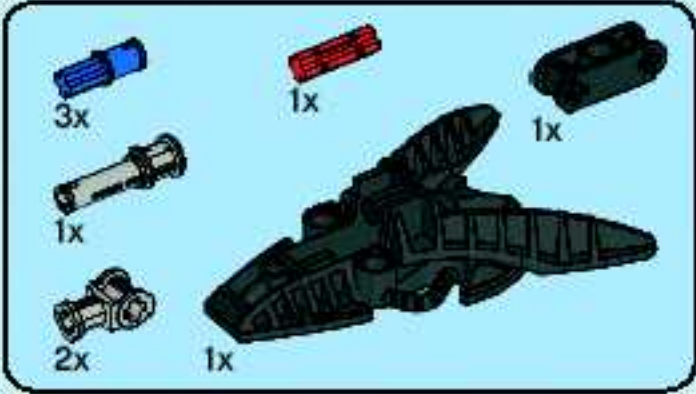

17

1



2



3

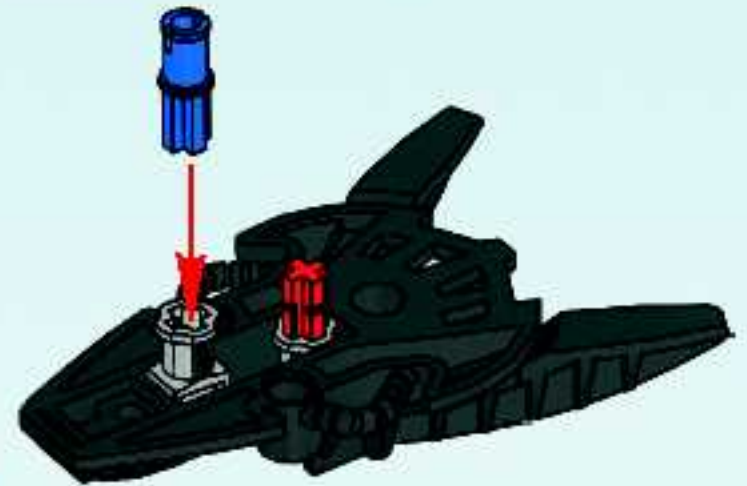

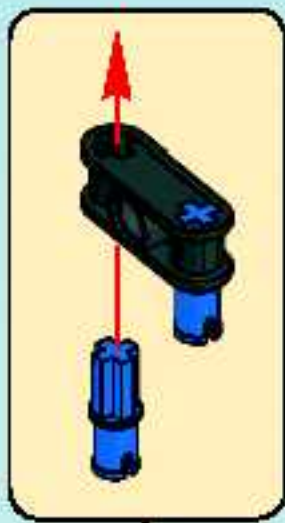

4

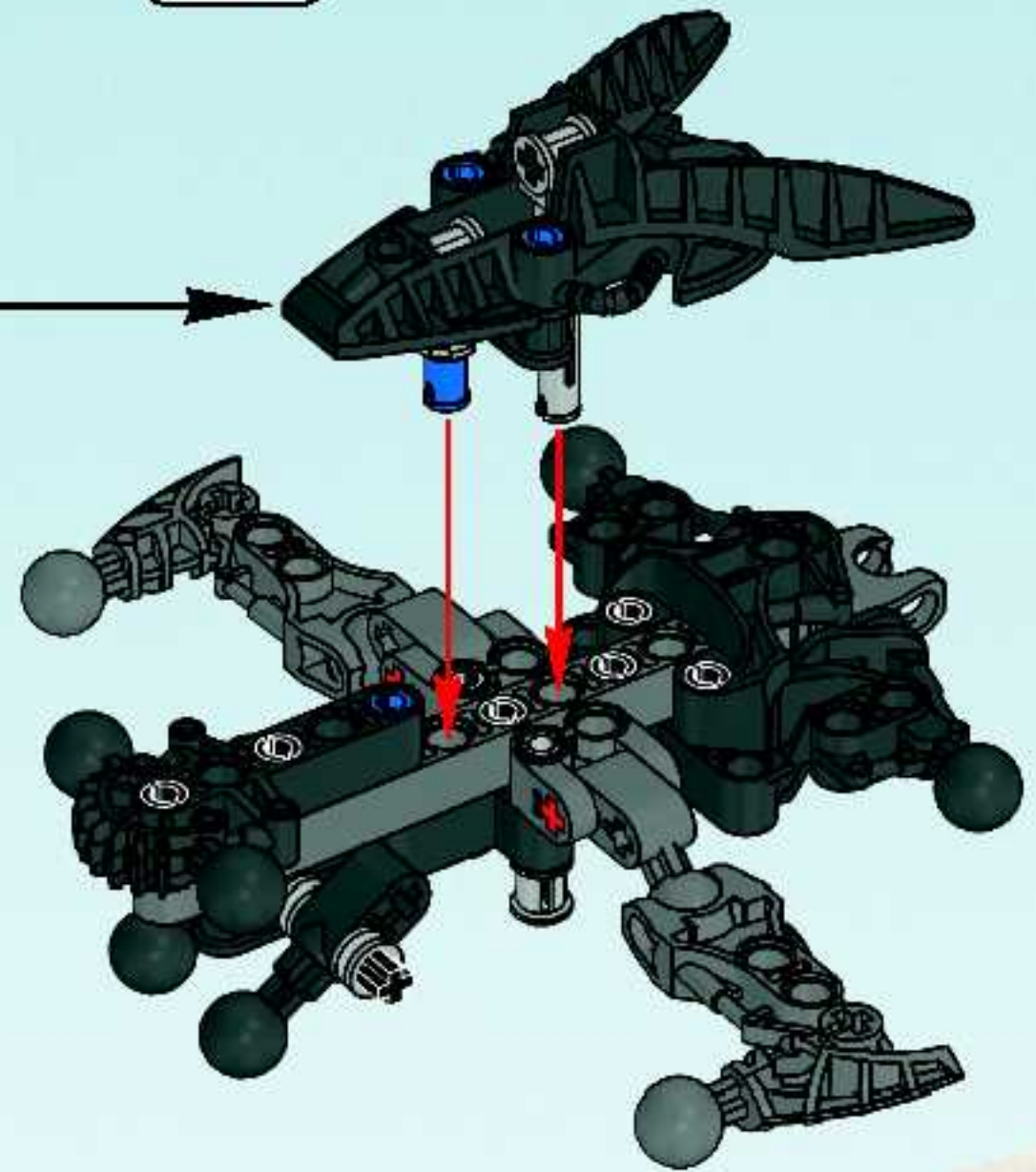
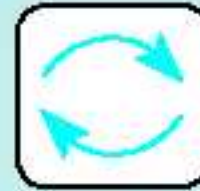

5

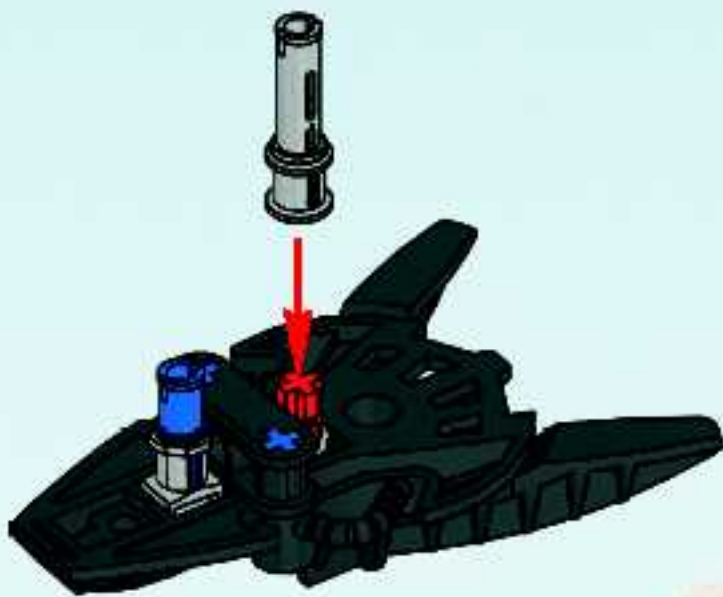



1

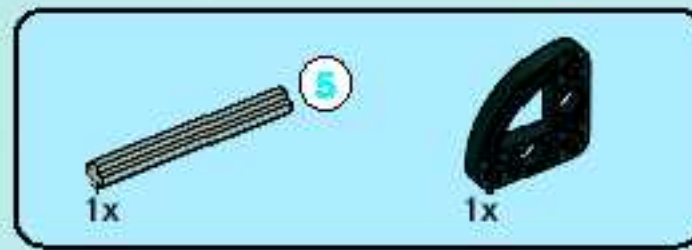
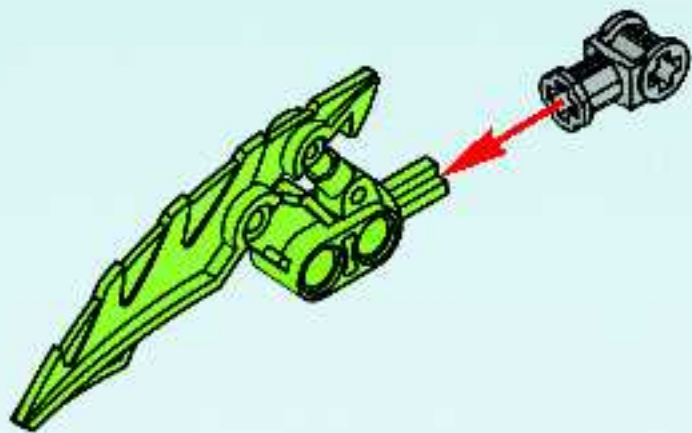

2

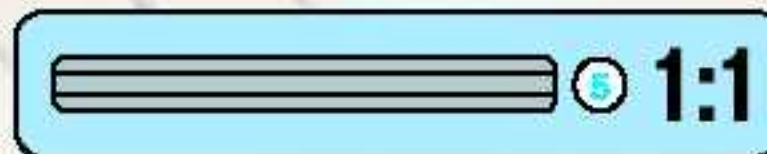
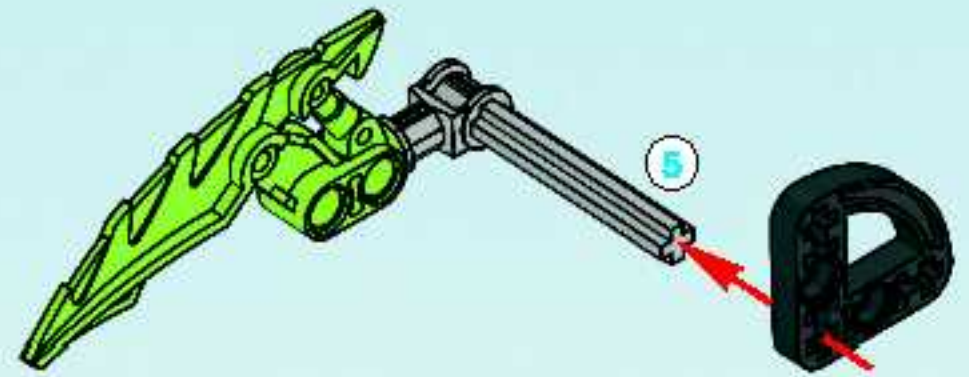

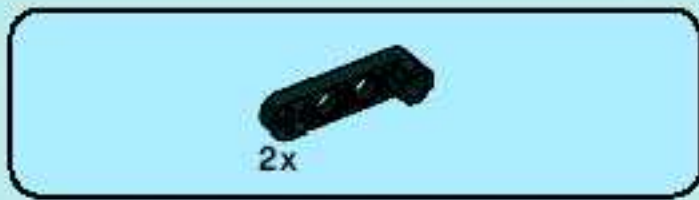

3

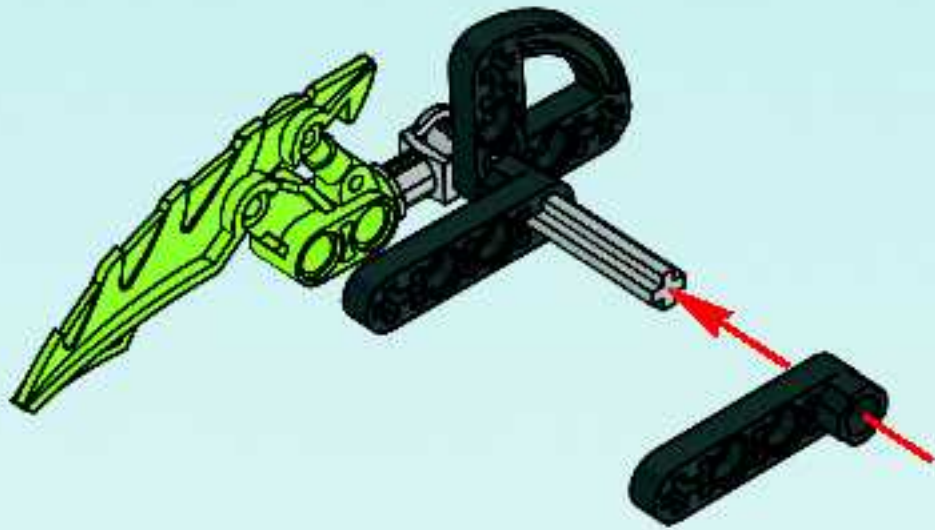

4

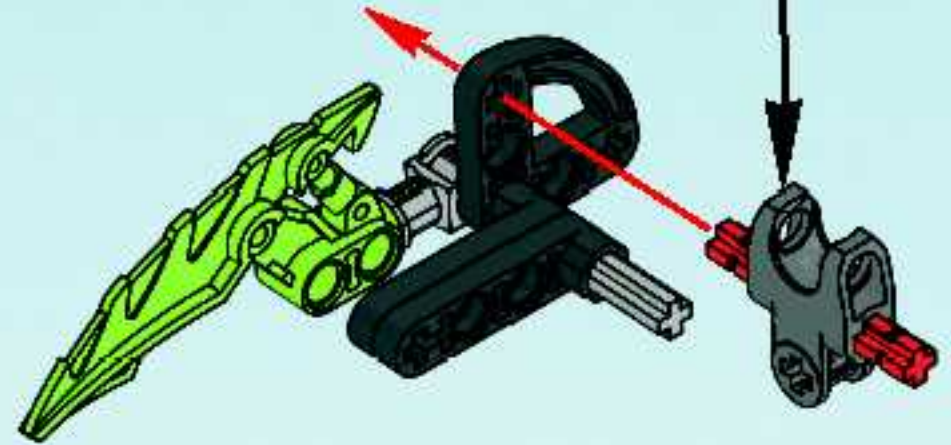
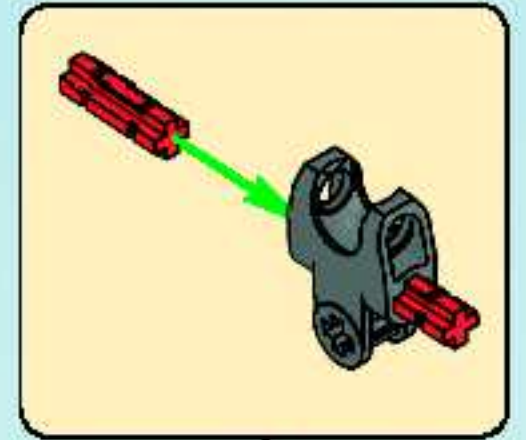



5

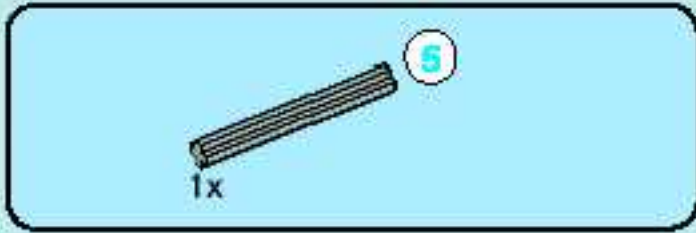
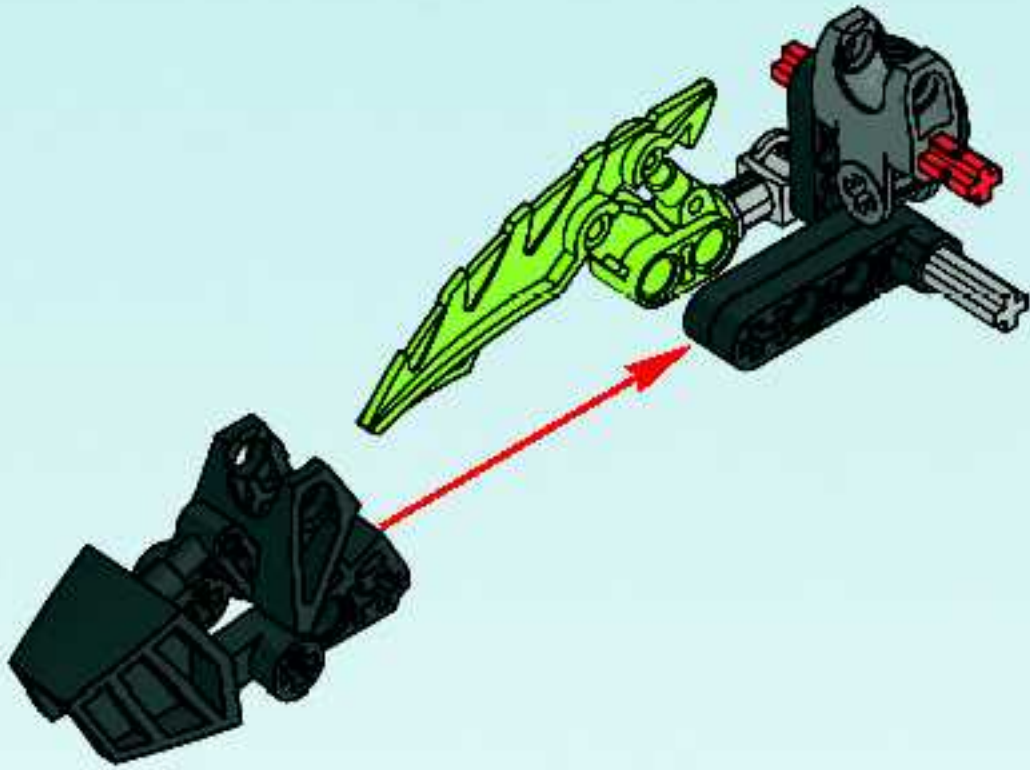

6

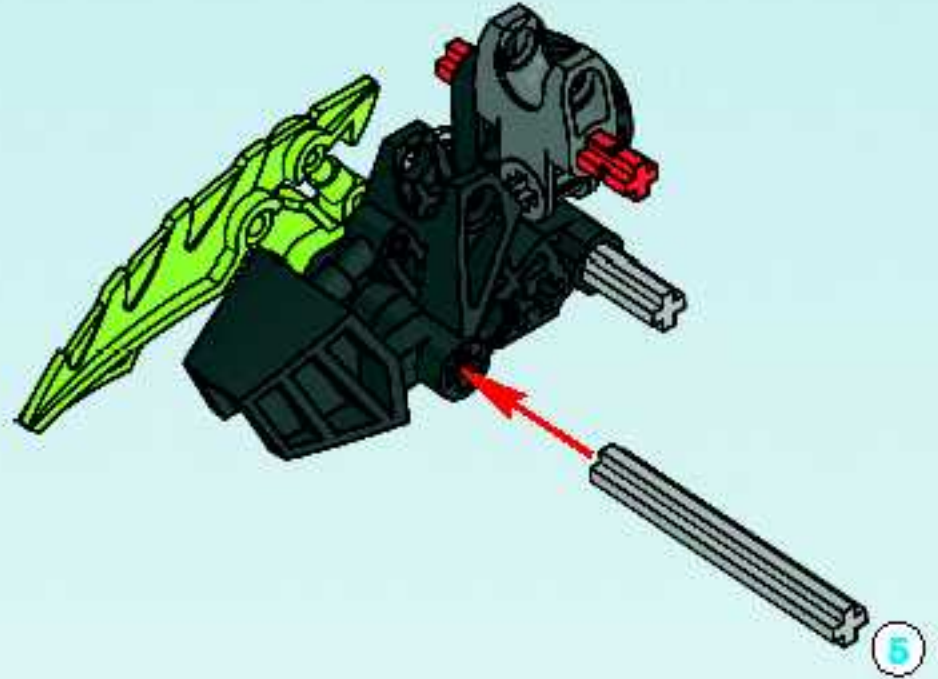



7

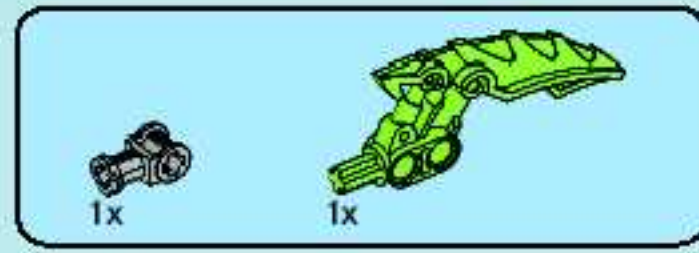

8

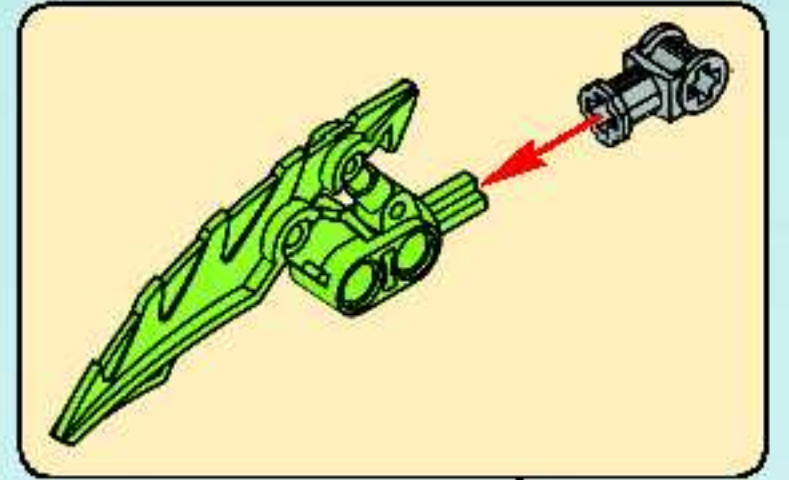

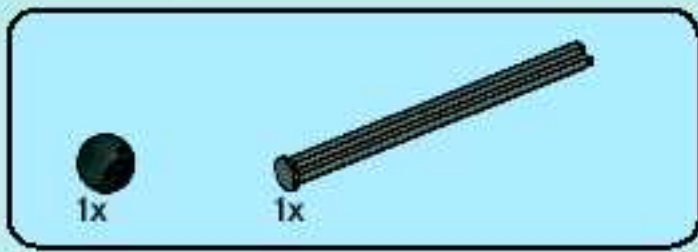

9

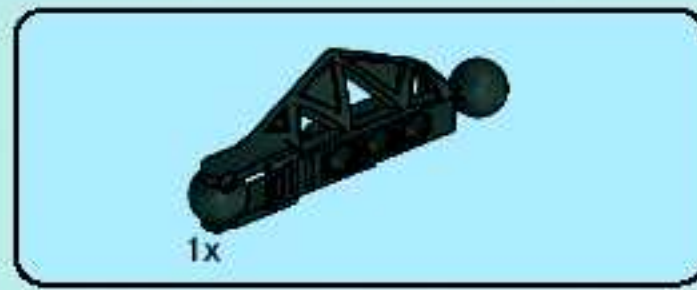
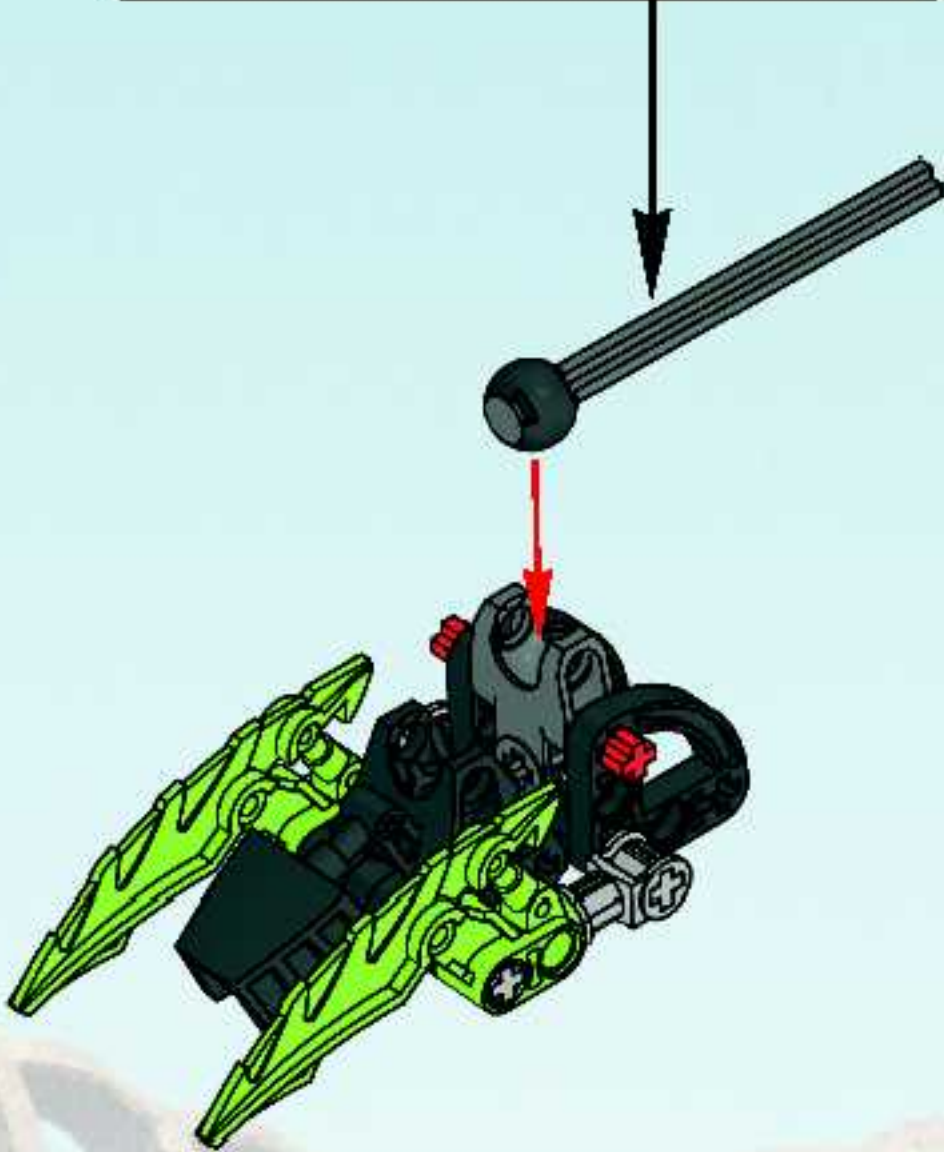
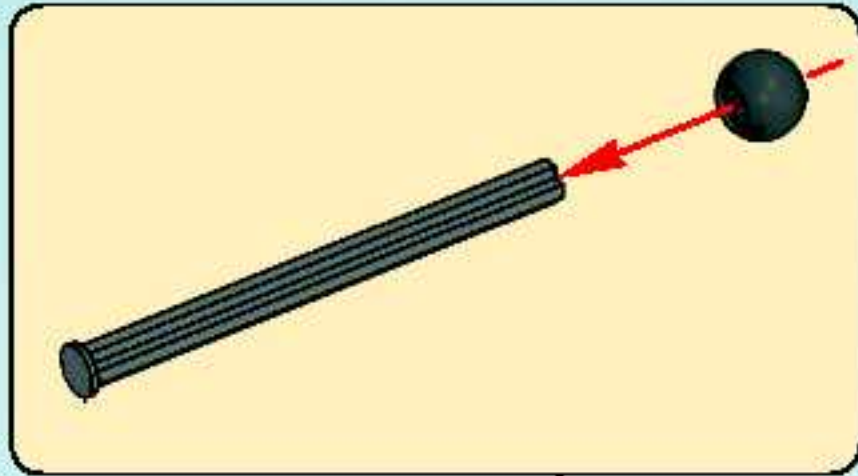

10

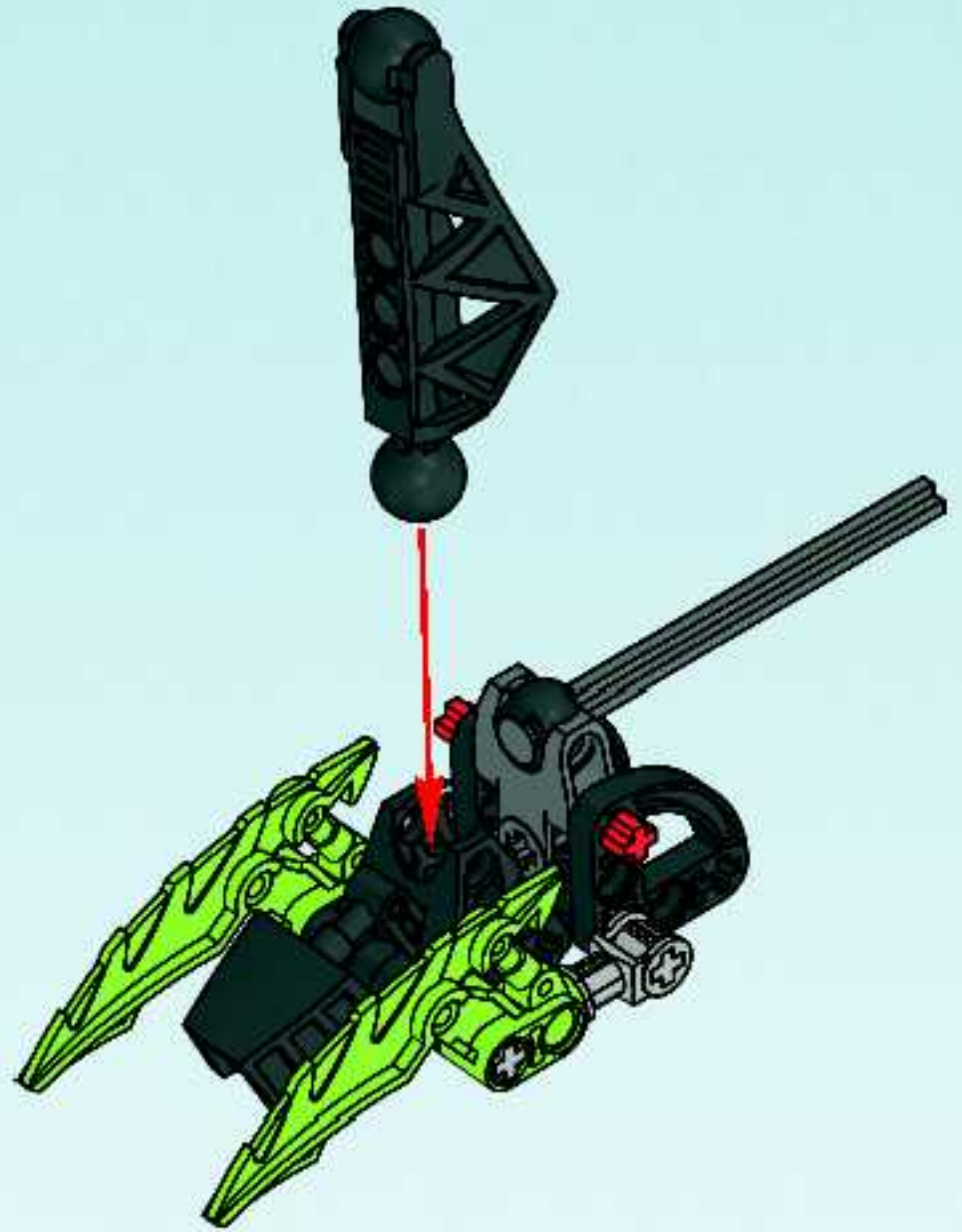

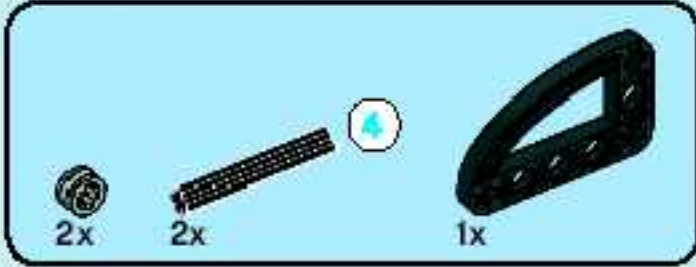
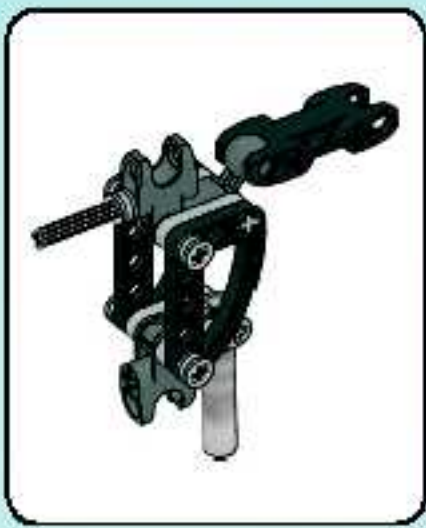

1

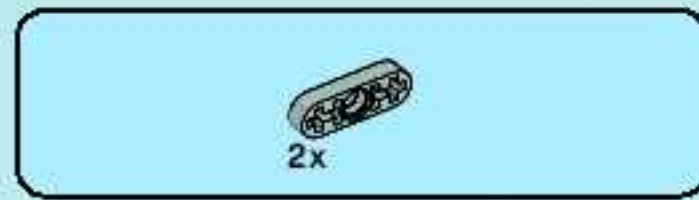
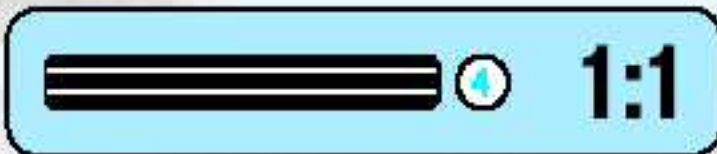
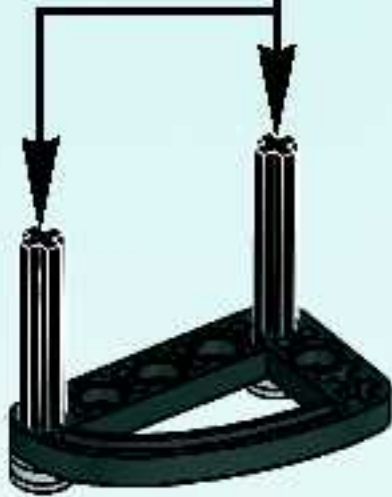

2

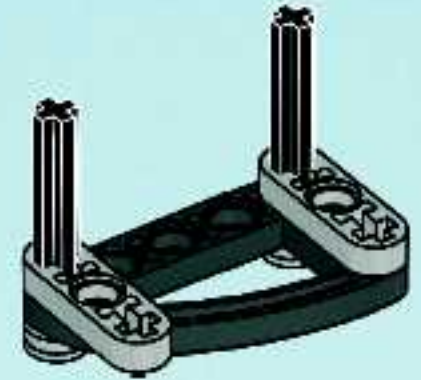

3

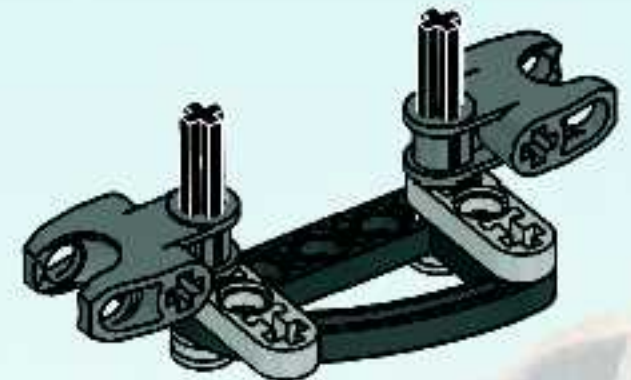

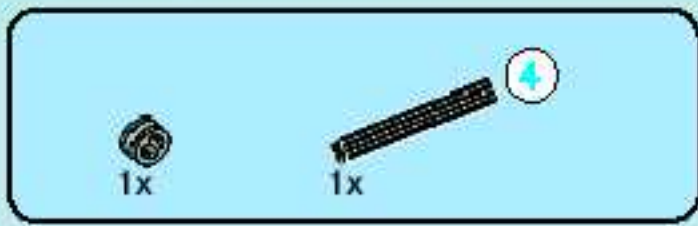

4

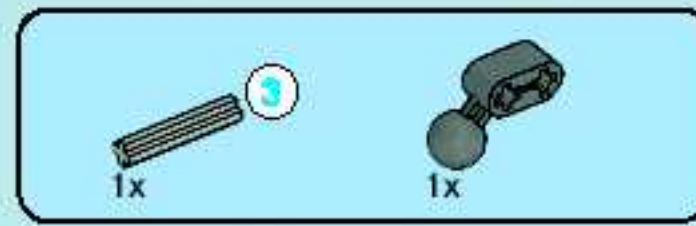
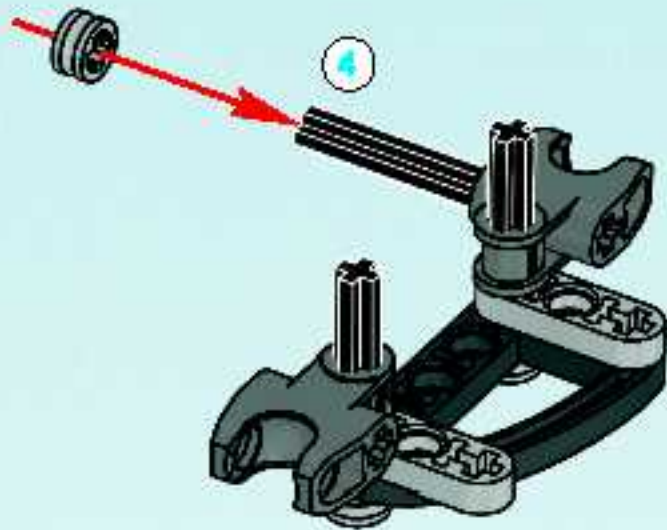

5

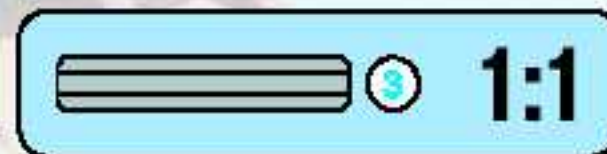
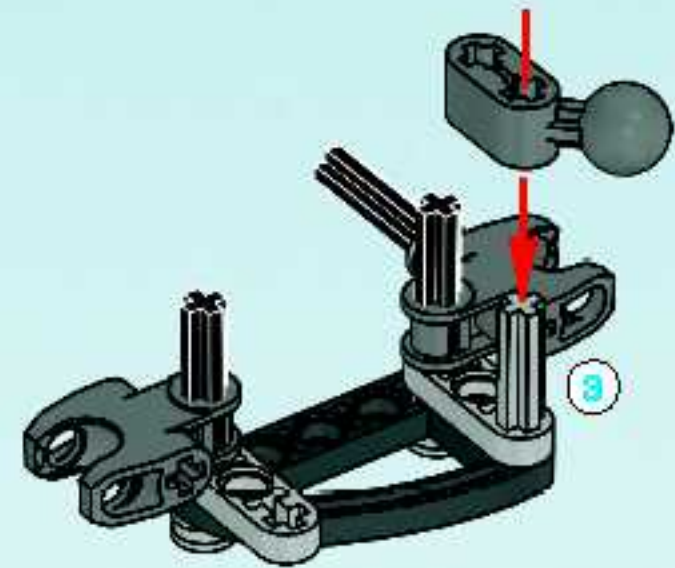



9

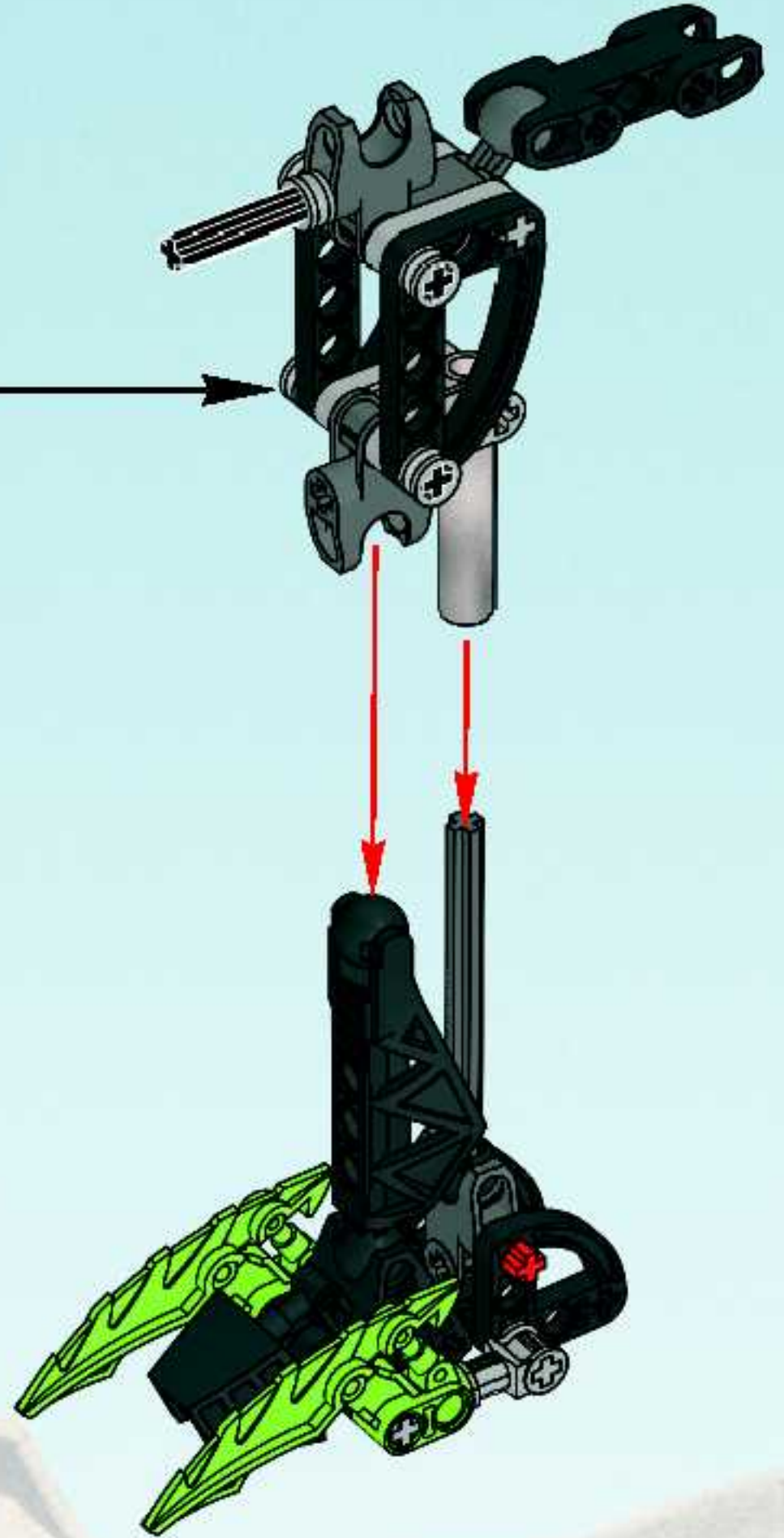
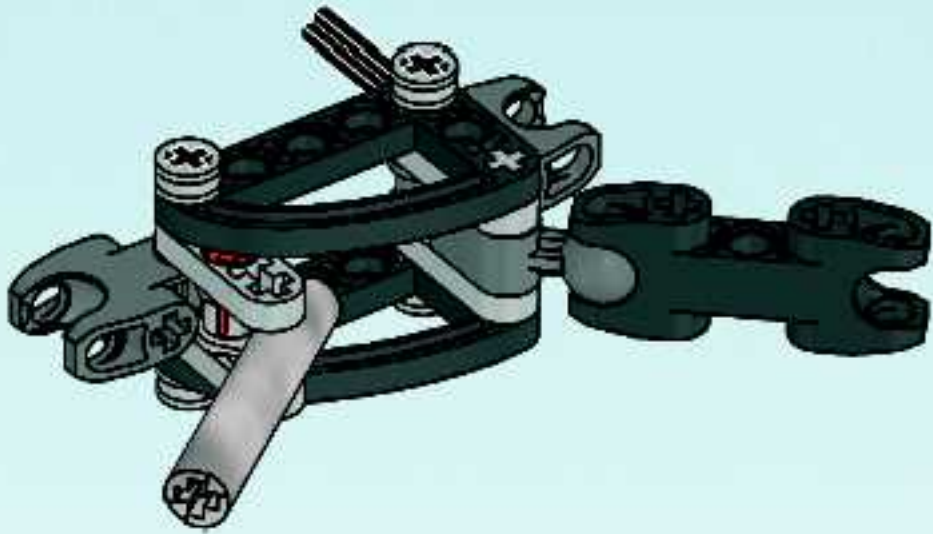

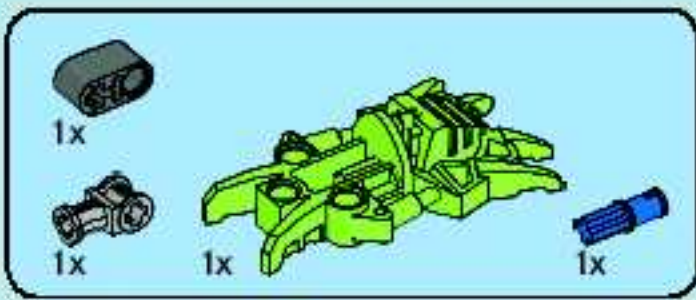

10

1

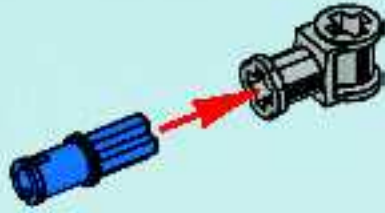

2

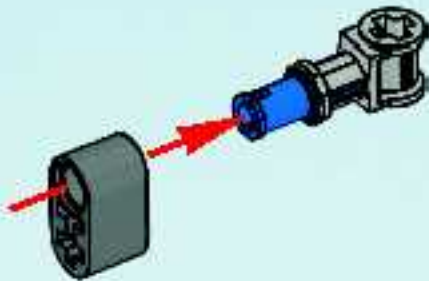

3

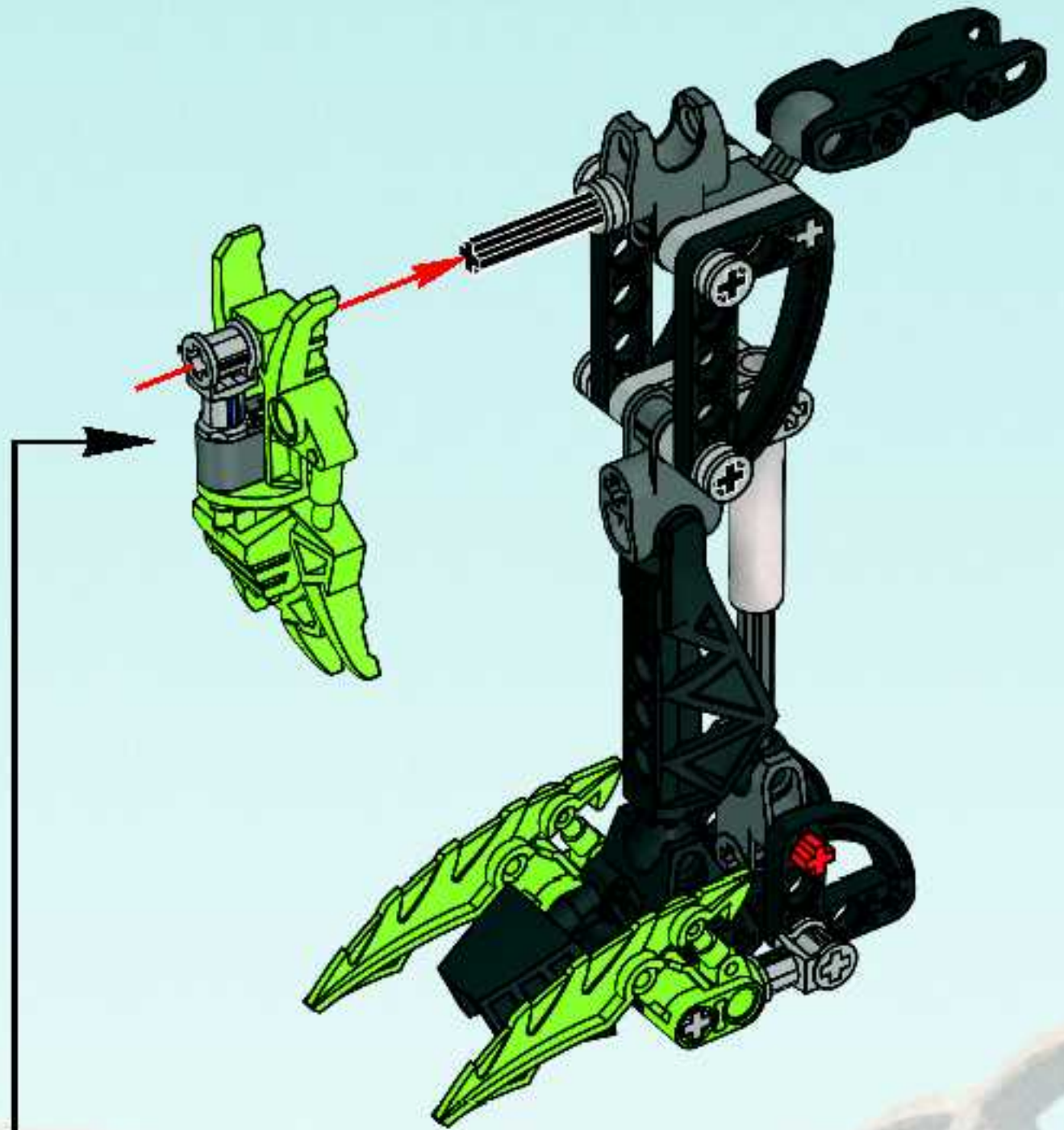
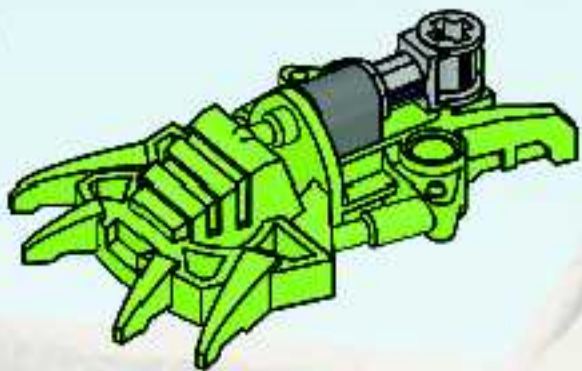

2x



11

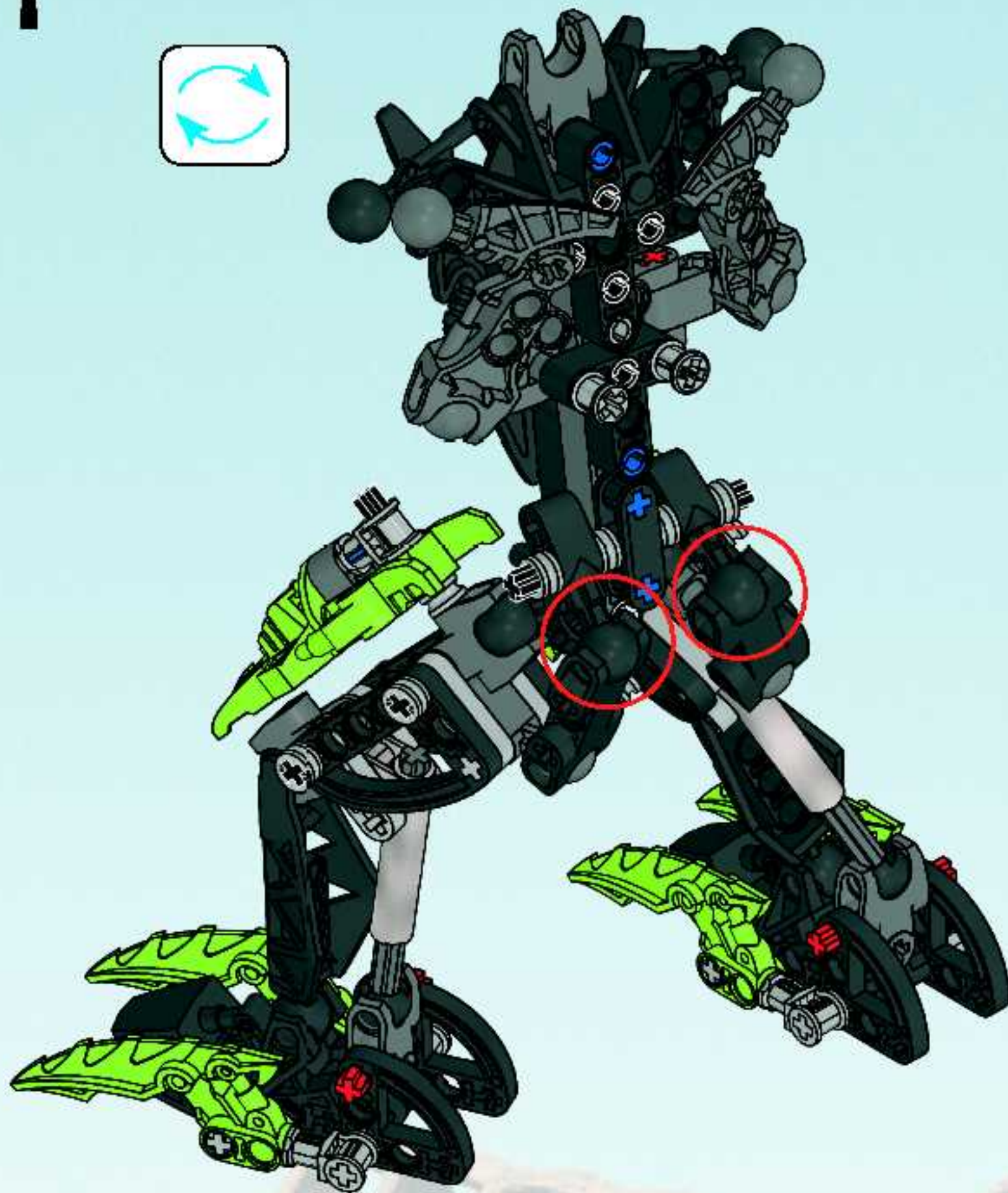

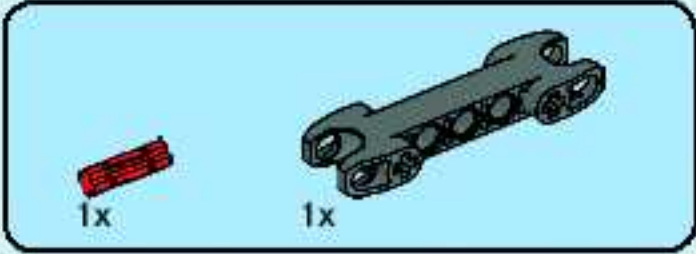

1

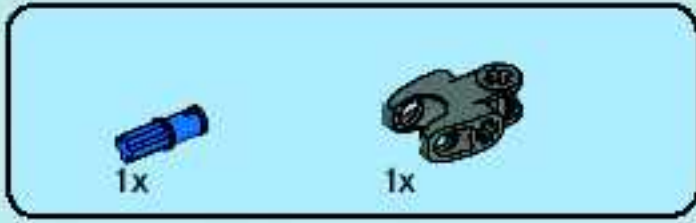
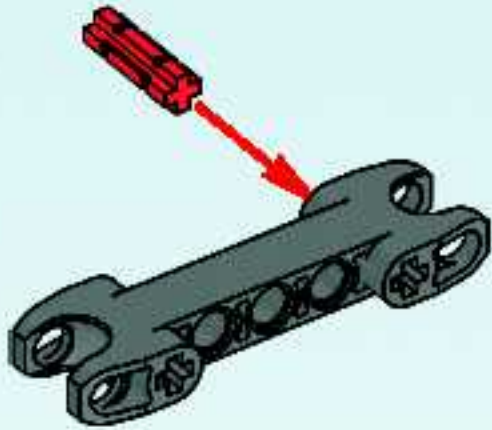

2

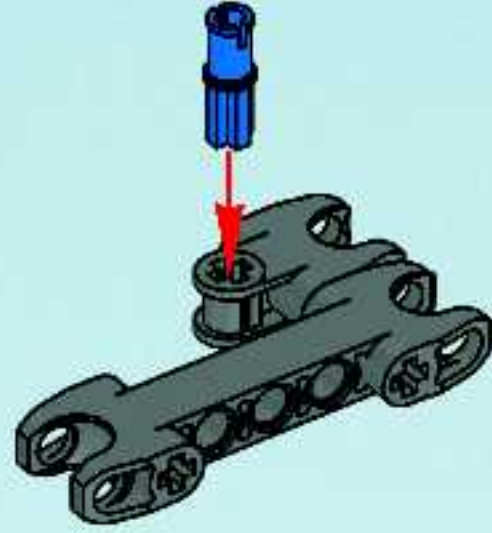

3

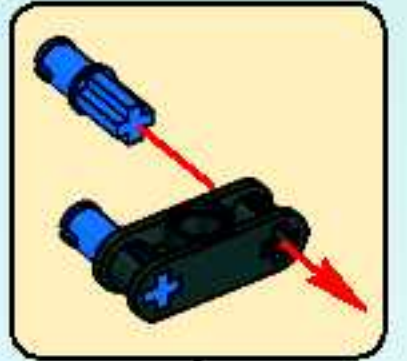
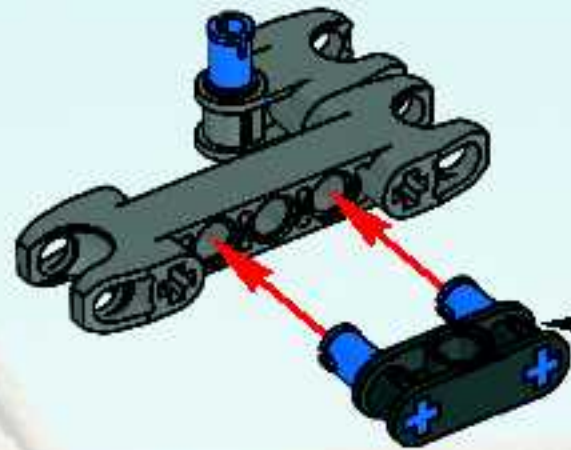

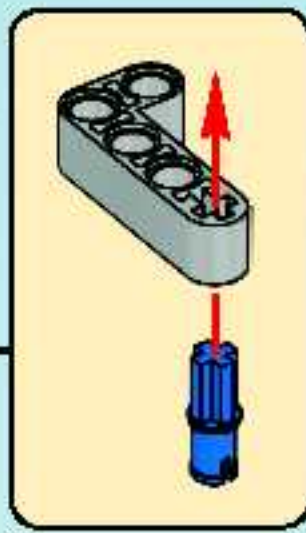
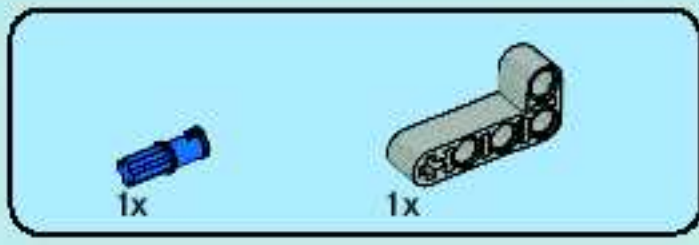

4

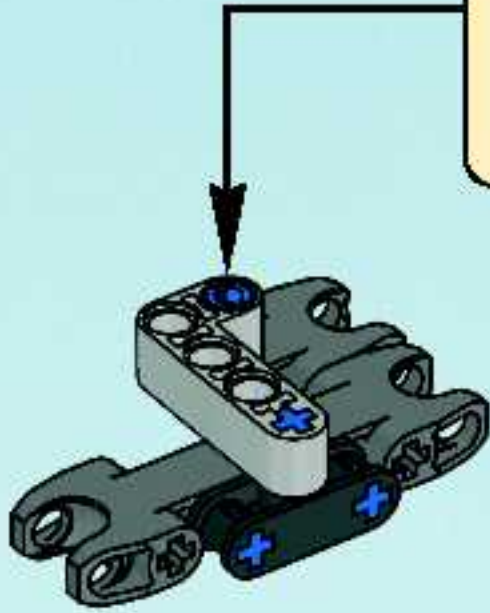

5

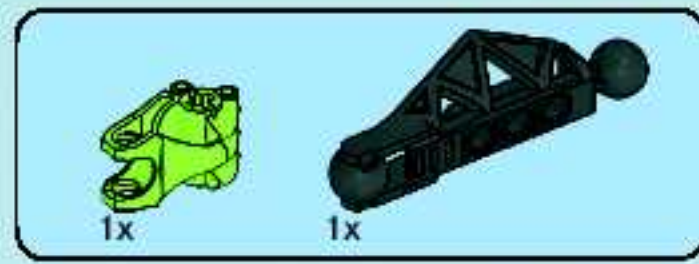
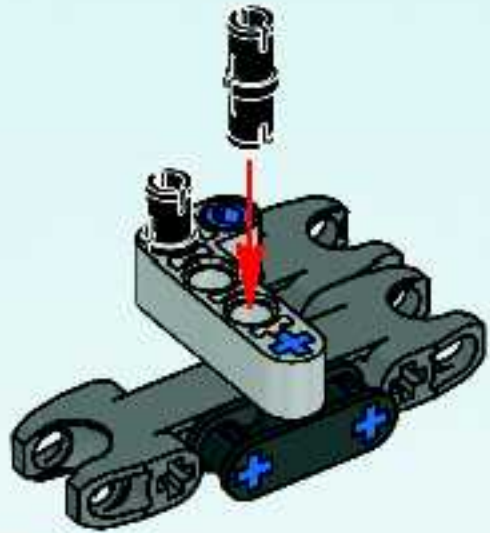

6

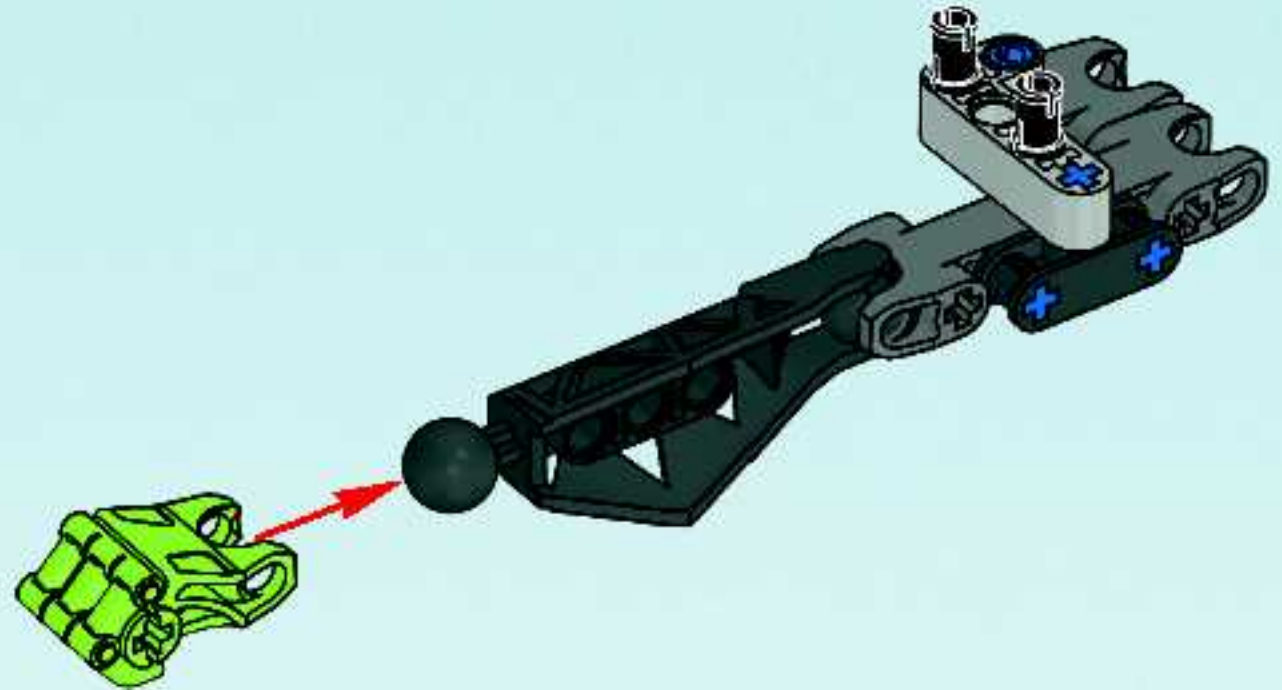

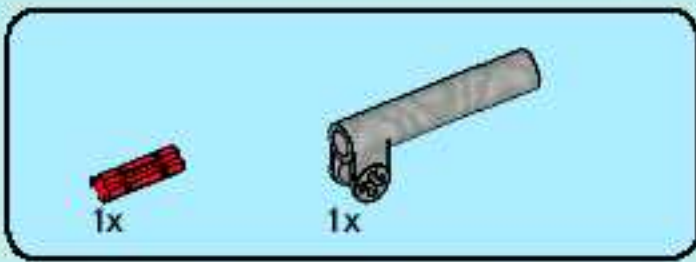

6

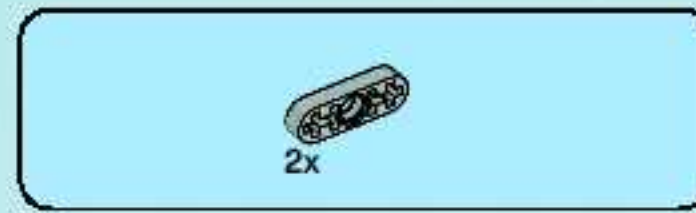
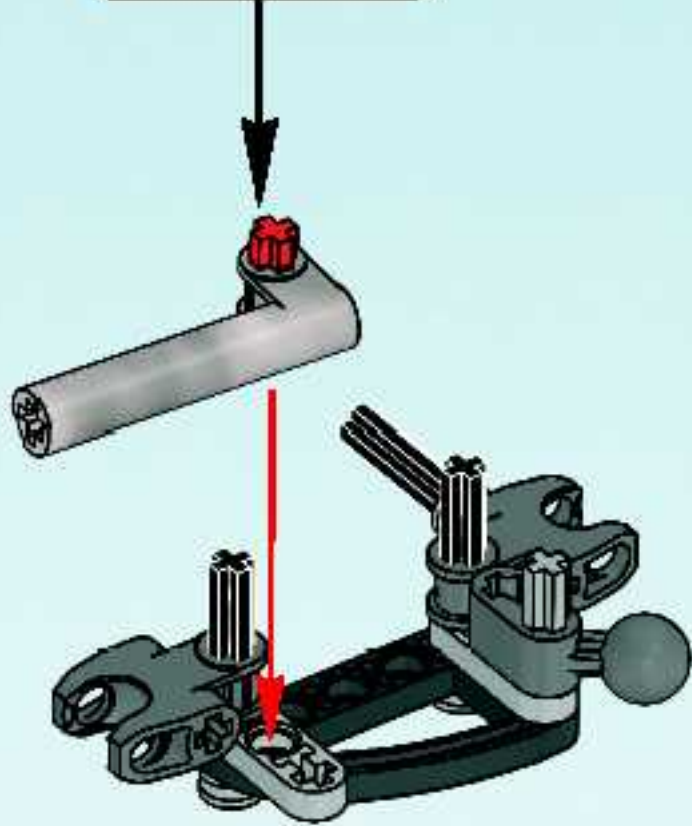
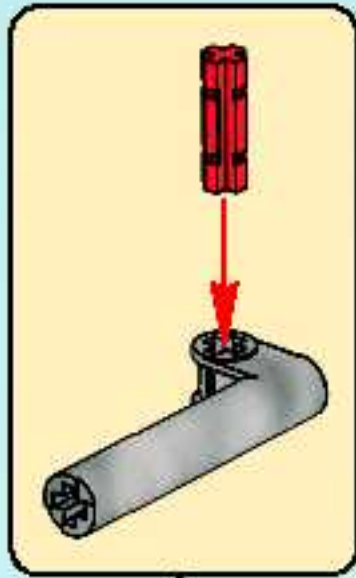

7

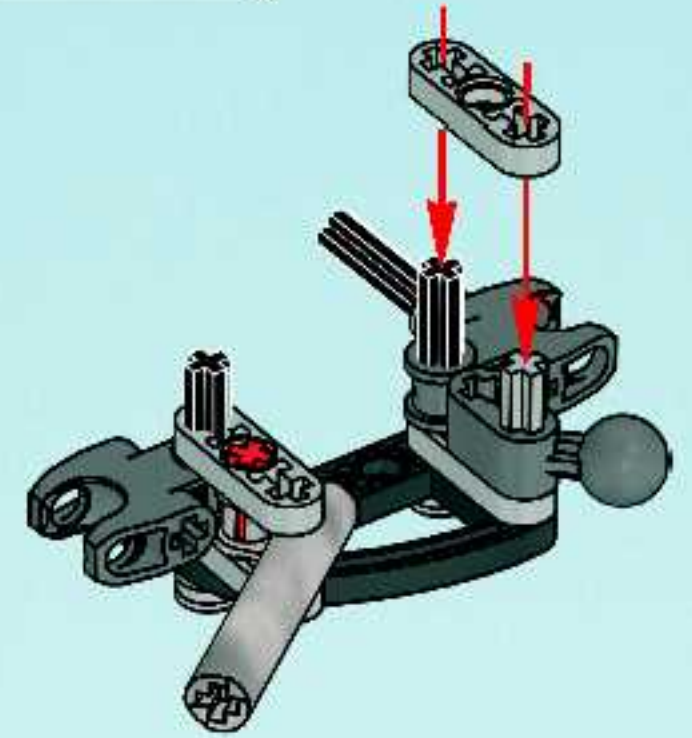

8

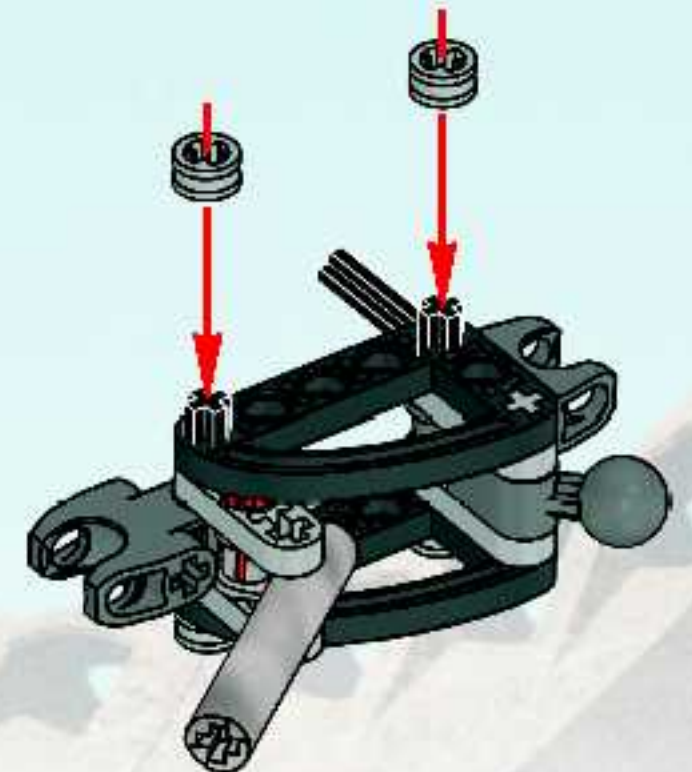

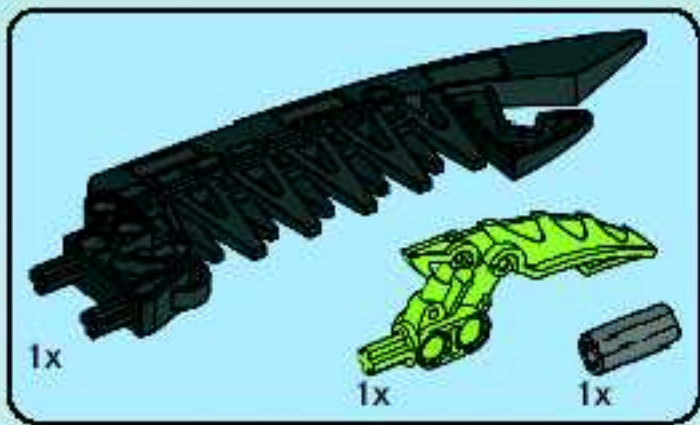

7

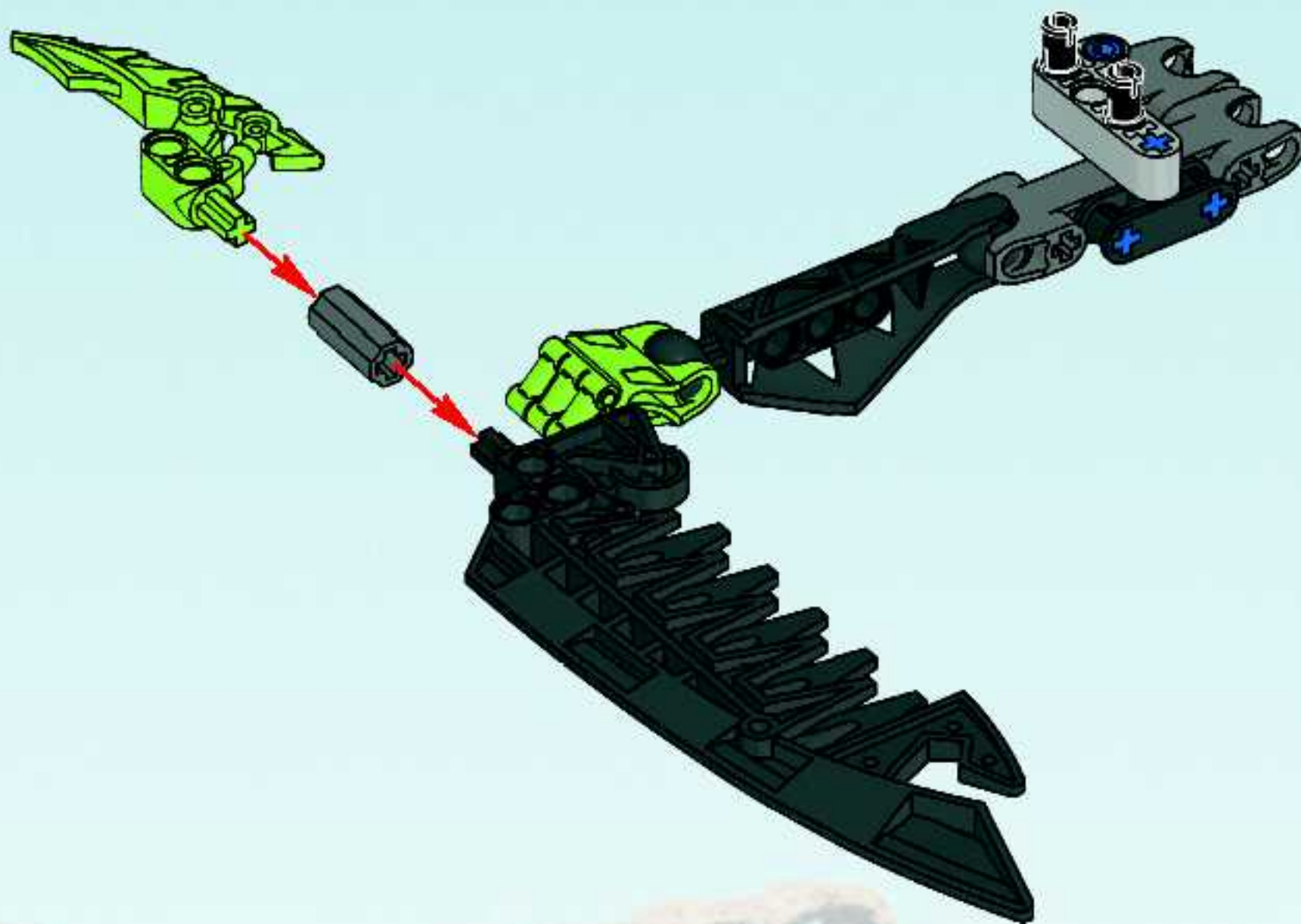

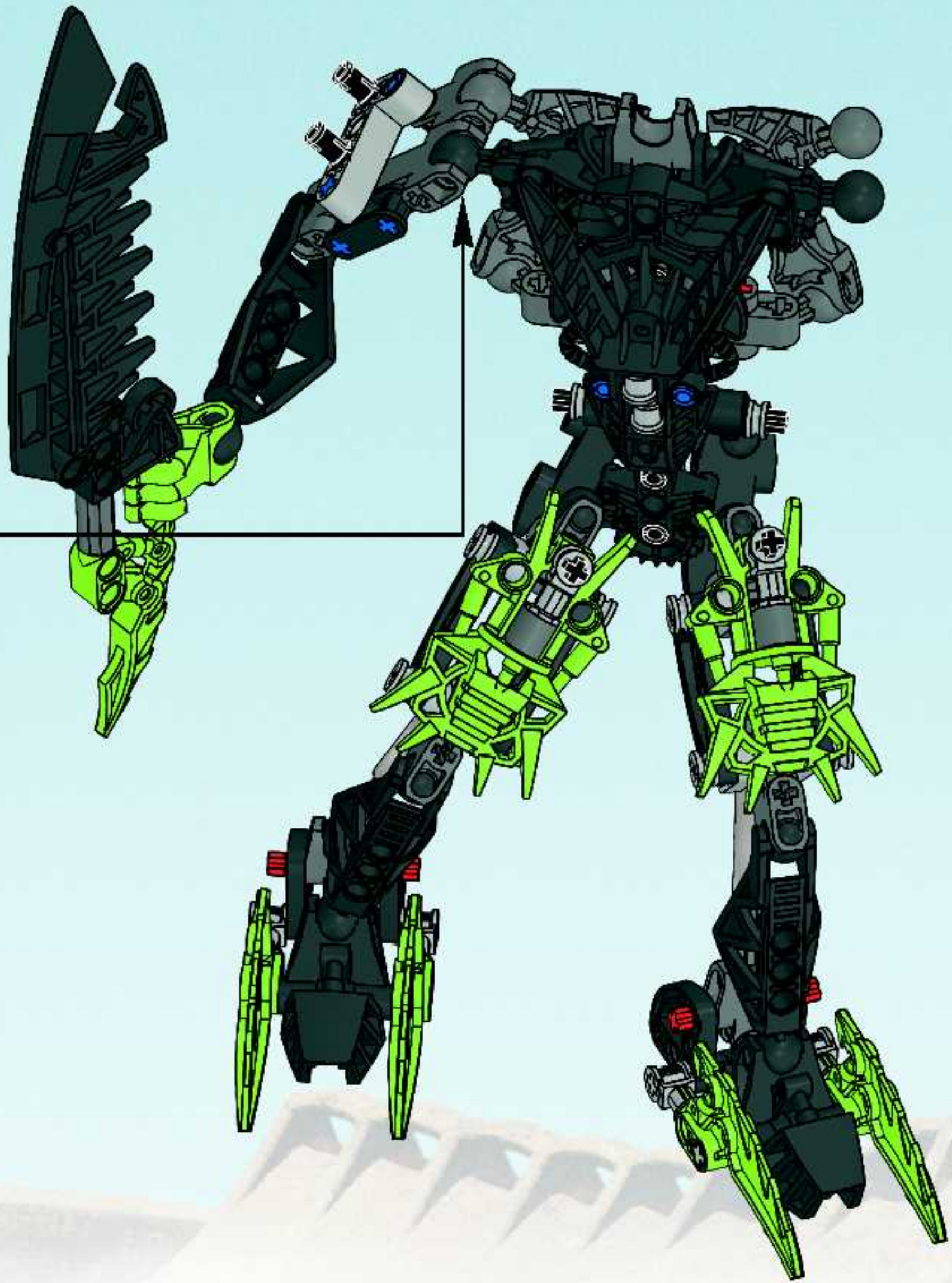

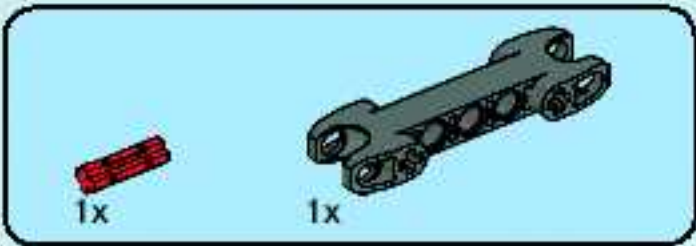

1

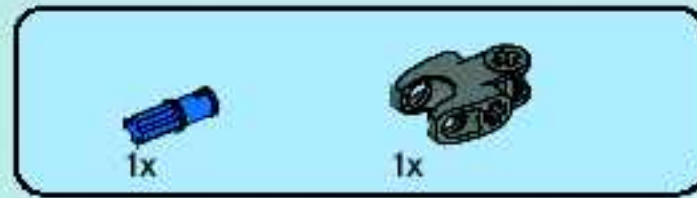
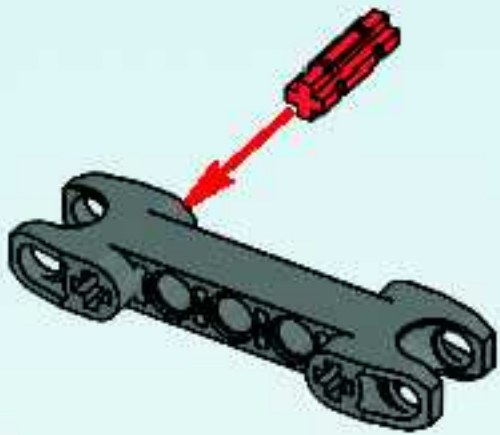

2

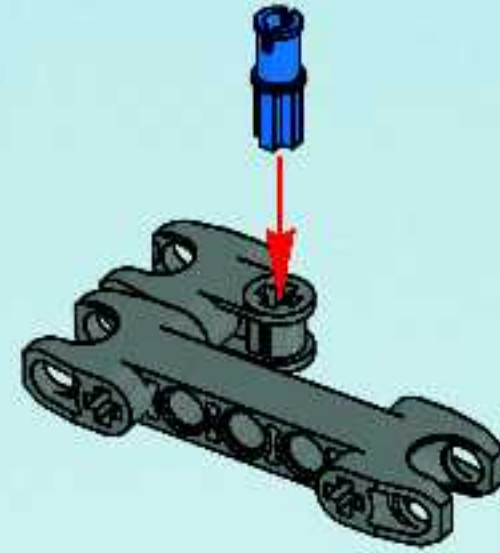

3

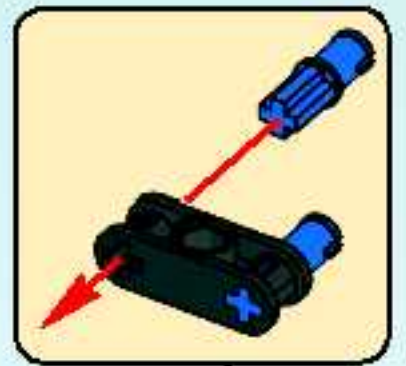
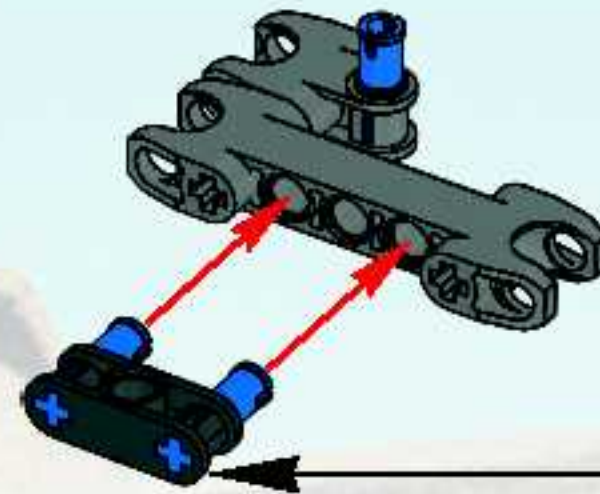

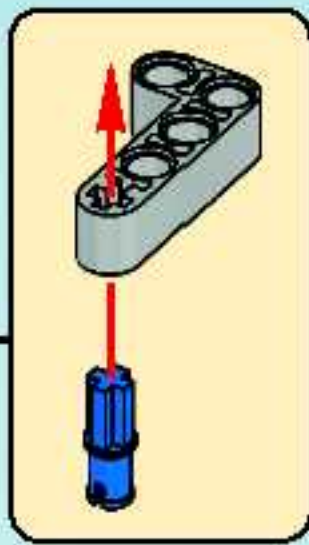
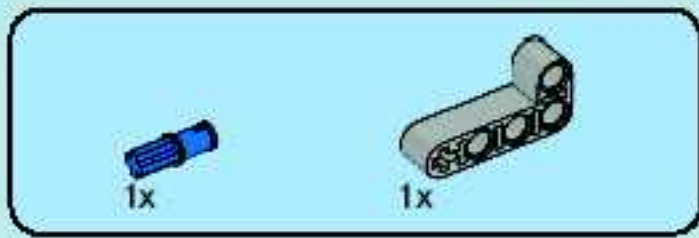

4

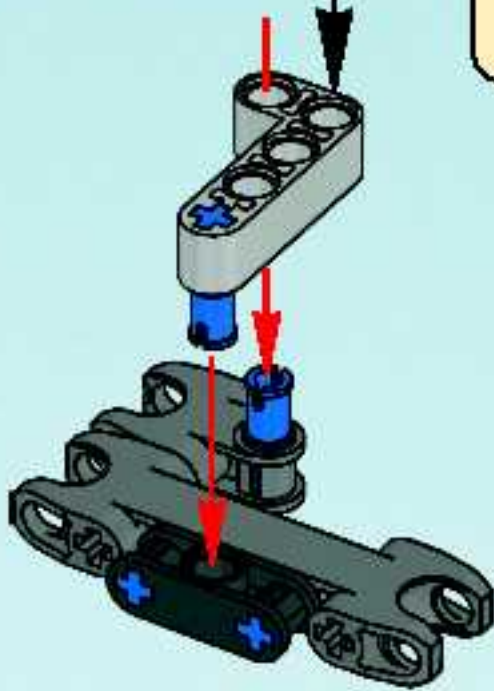

5

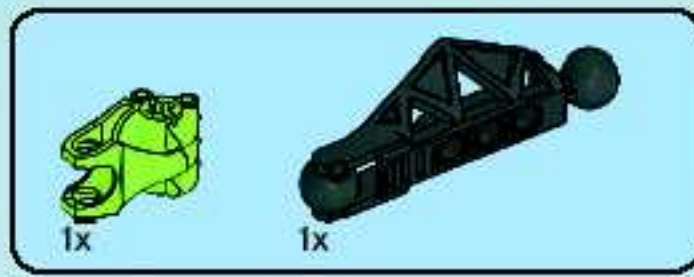
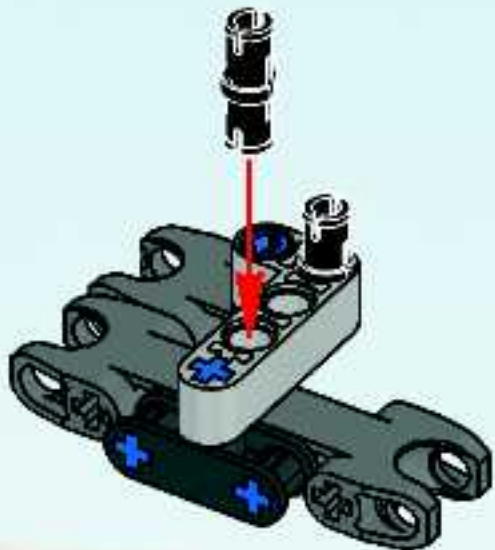

6

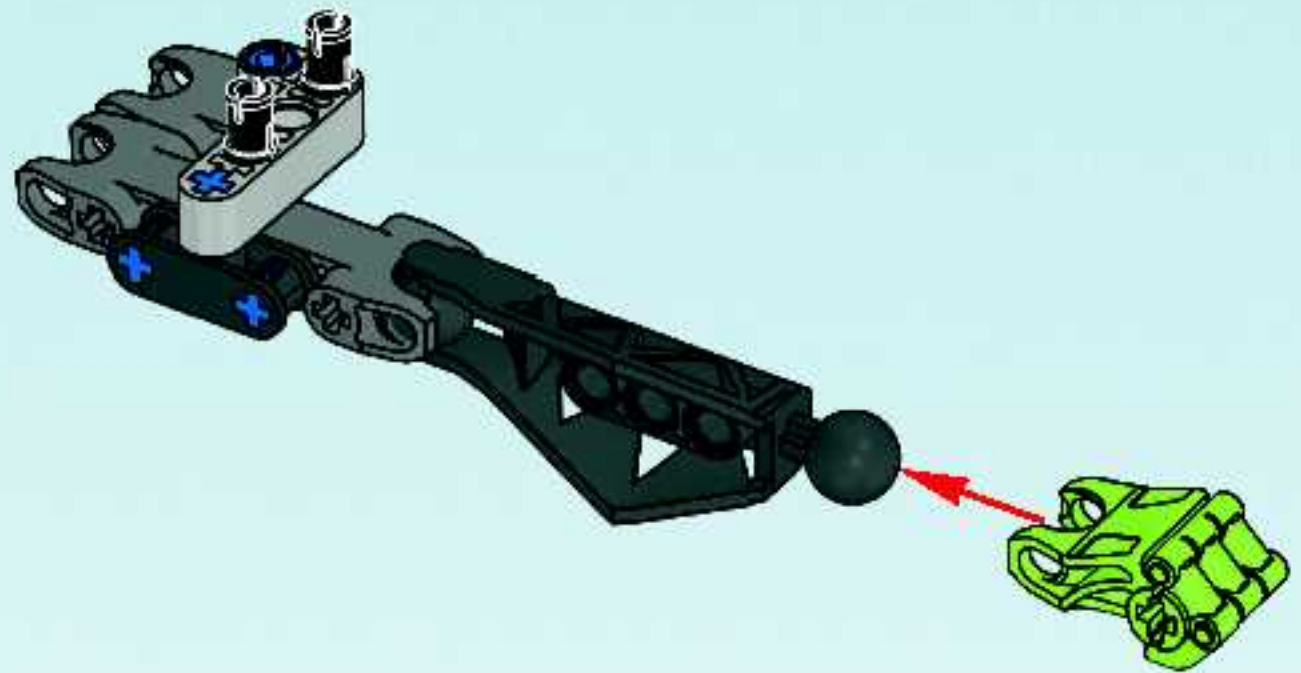



2x

7

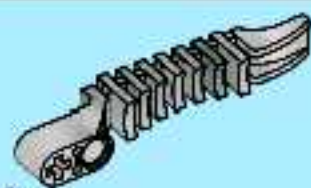
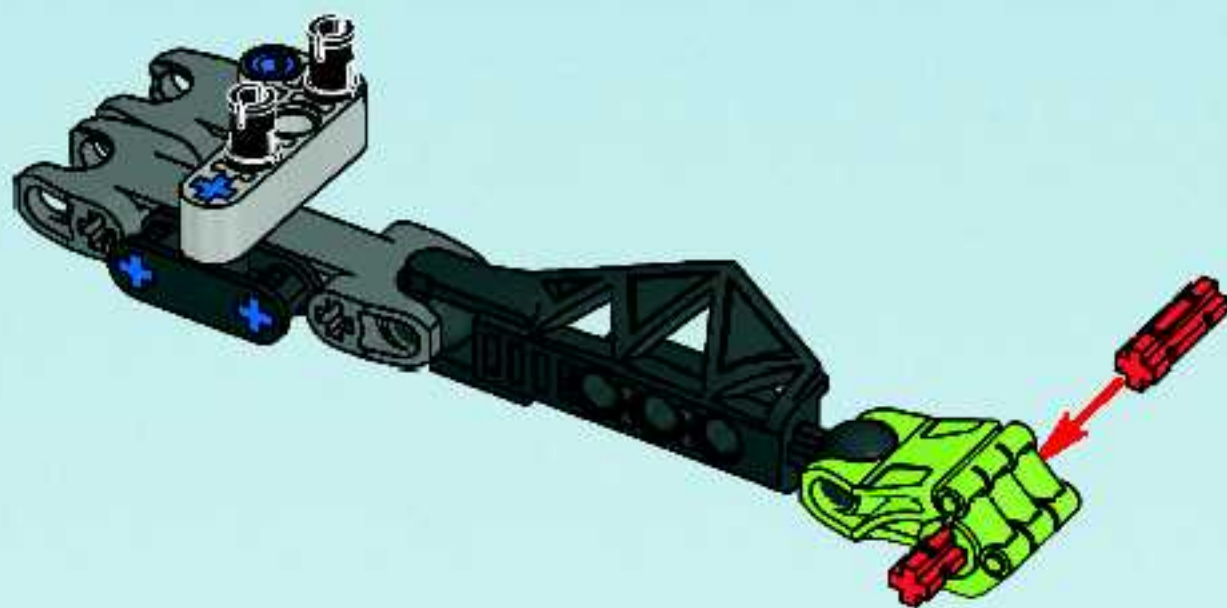

2x

8

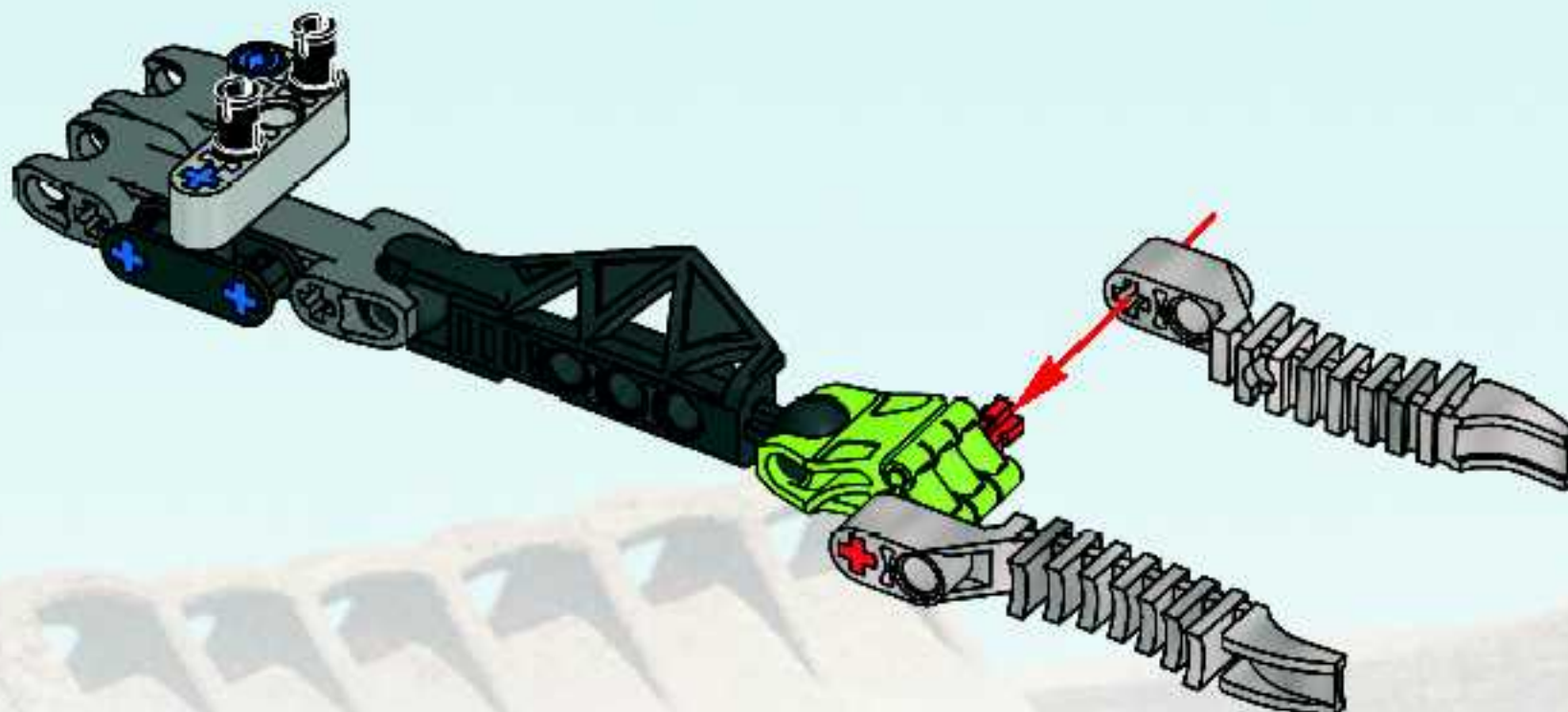



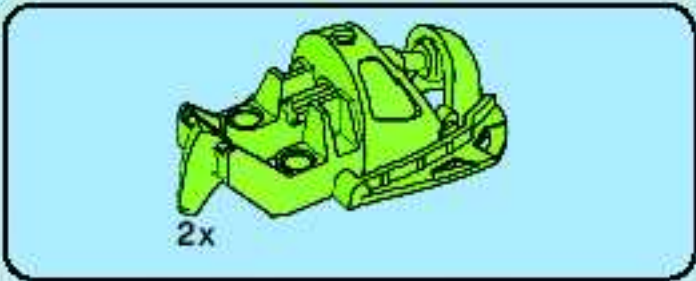

9

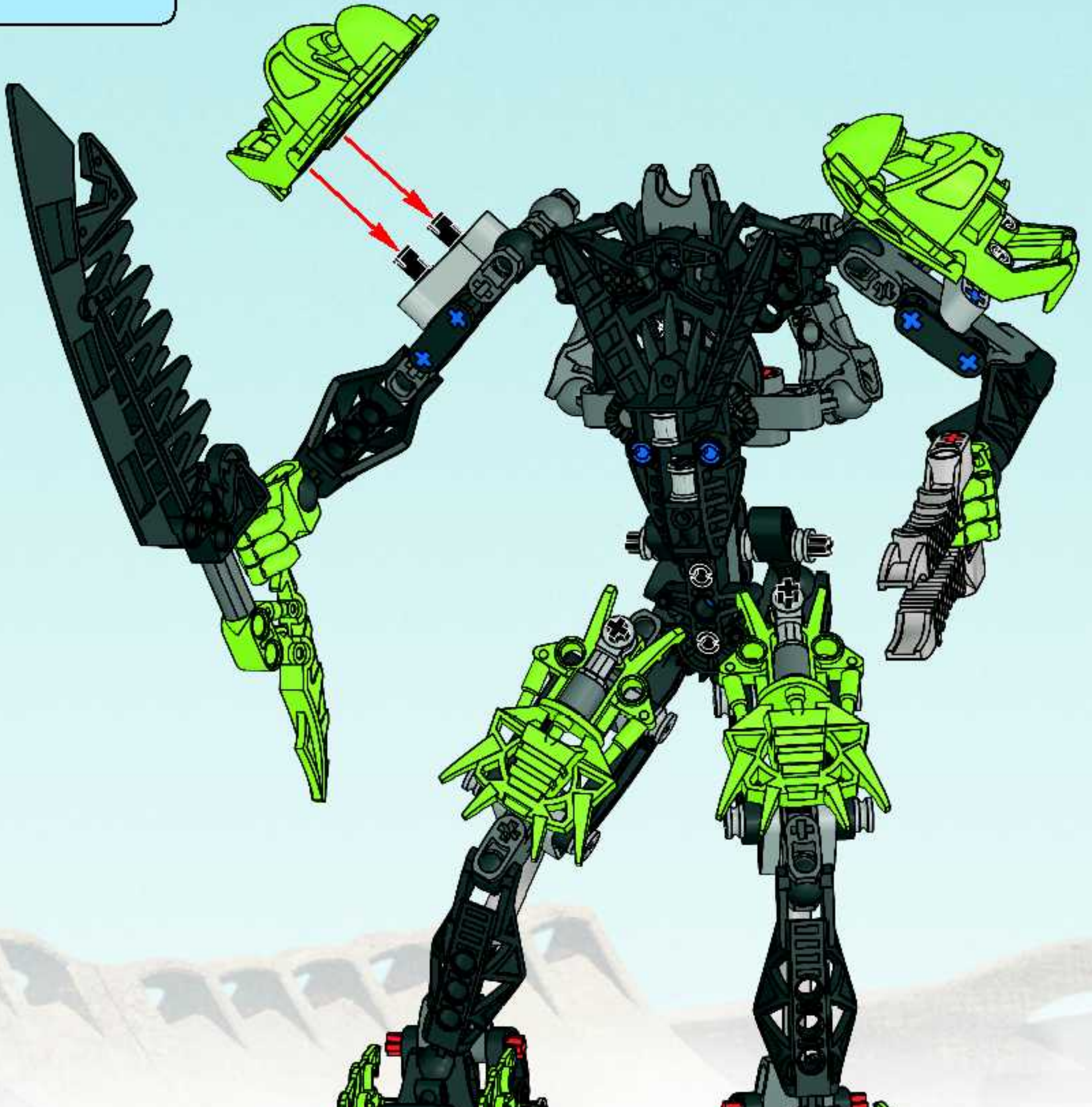

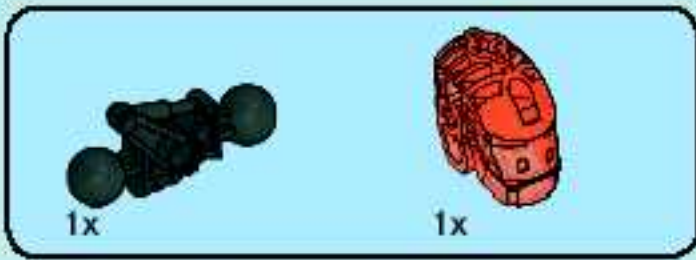

10

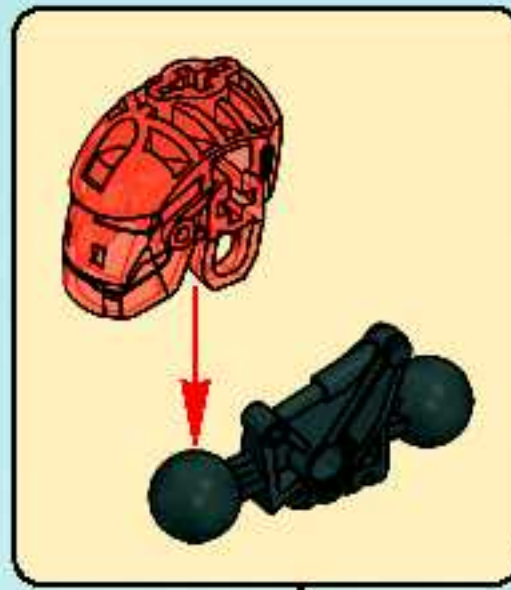

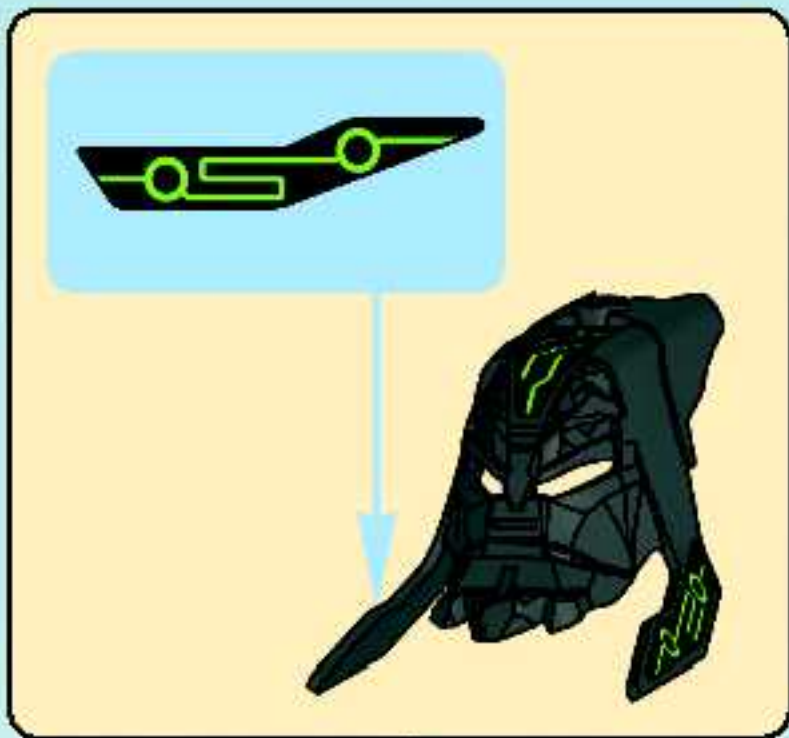
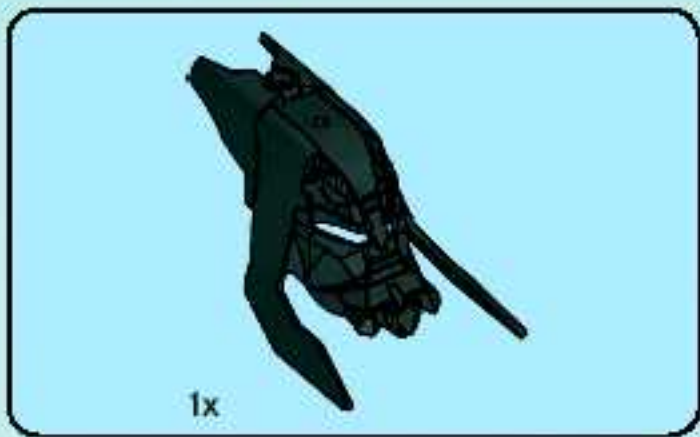

11



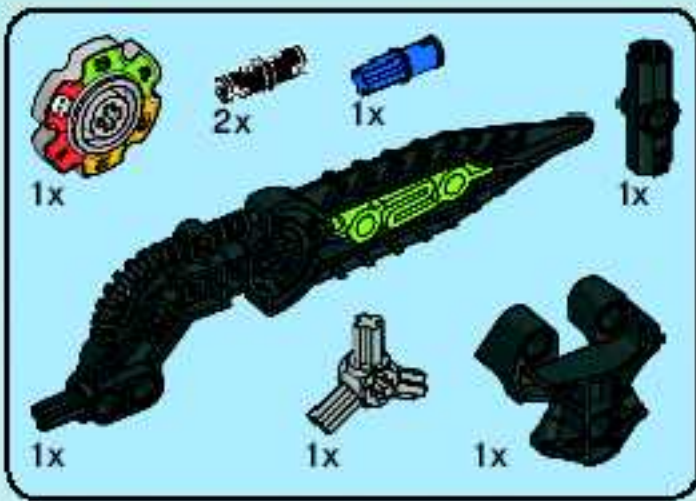

12

1



2

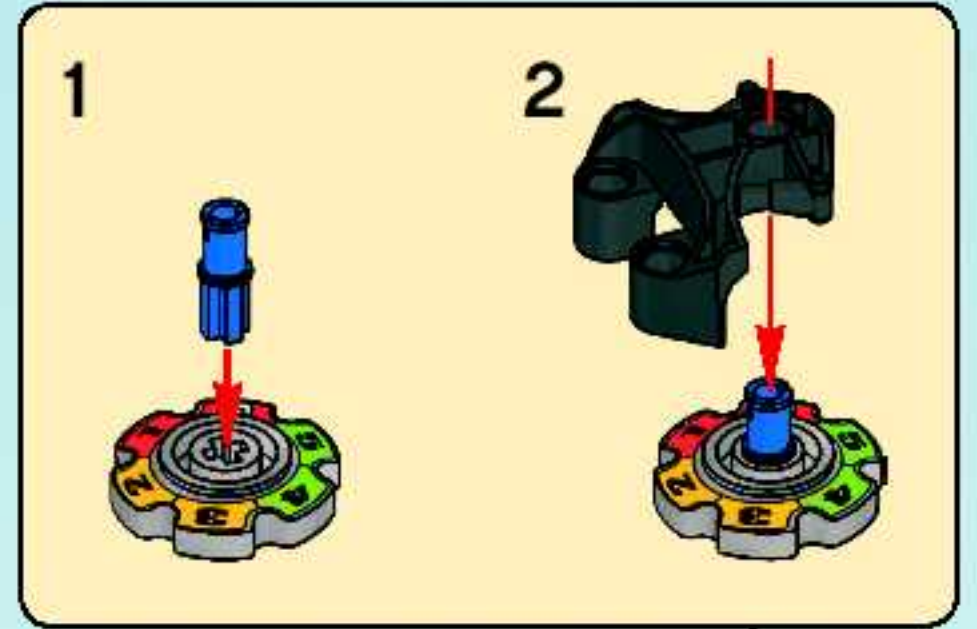

3



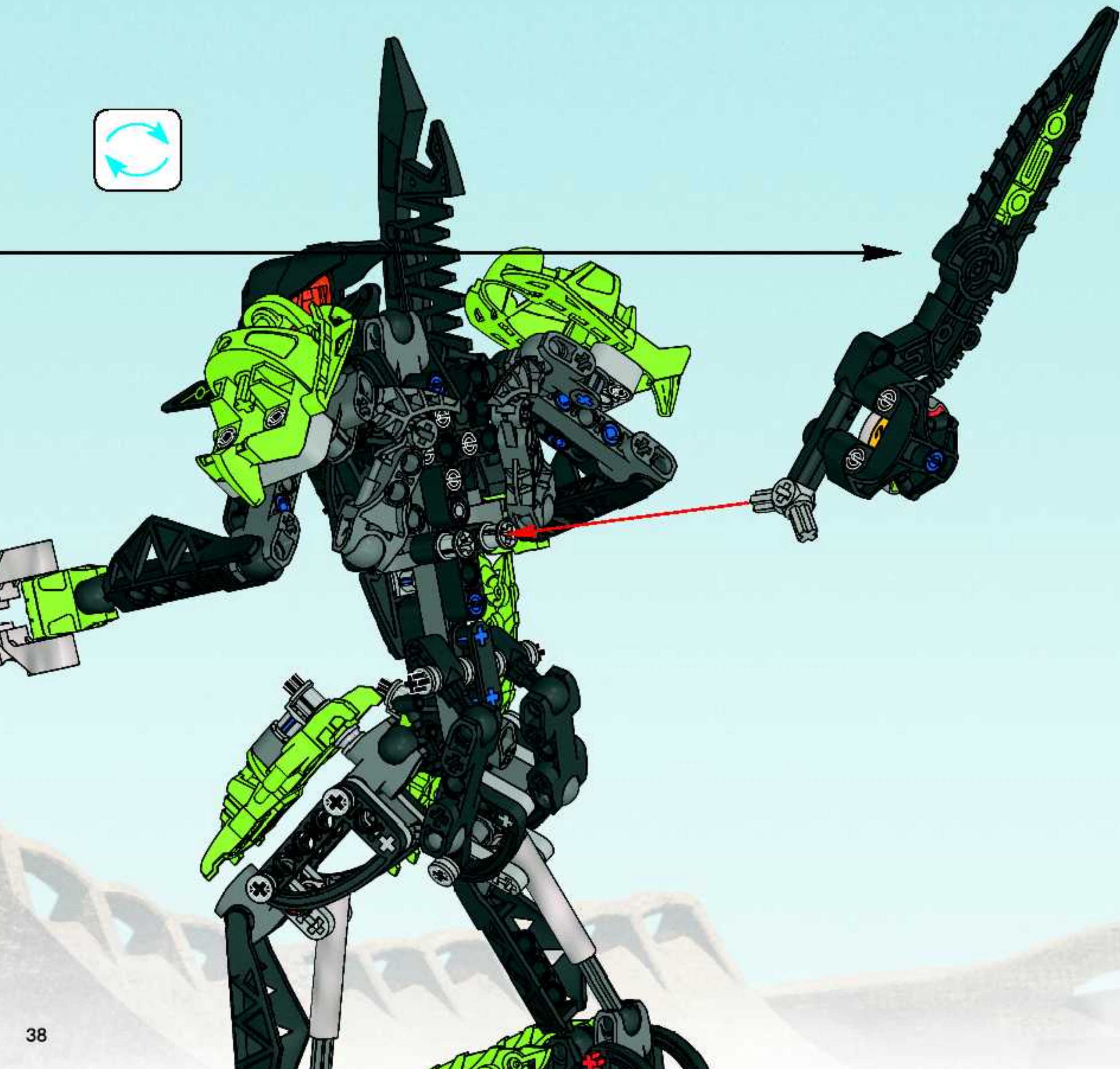

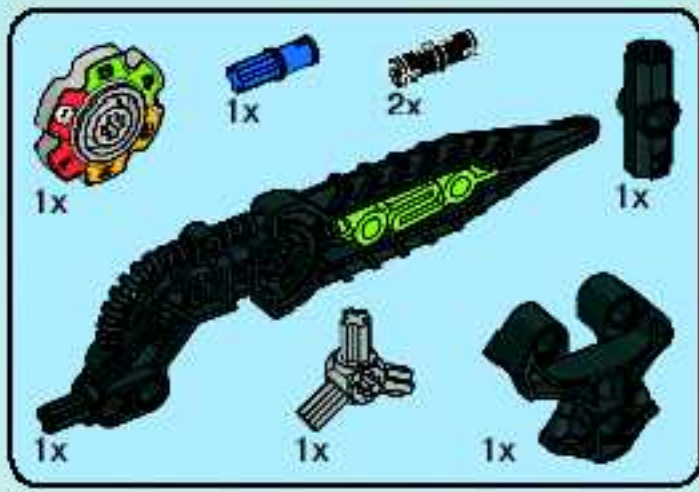

13

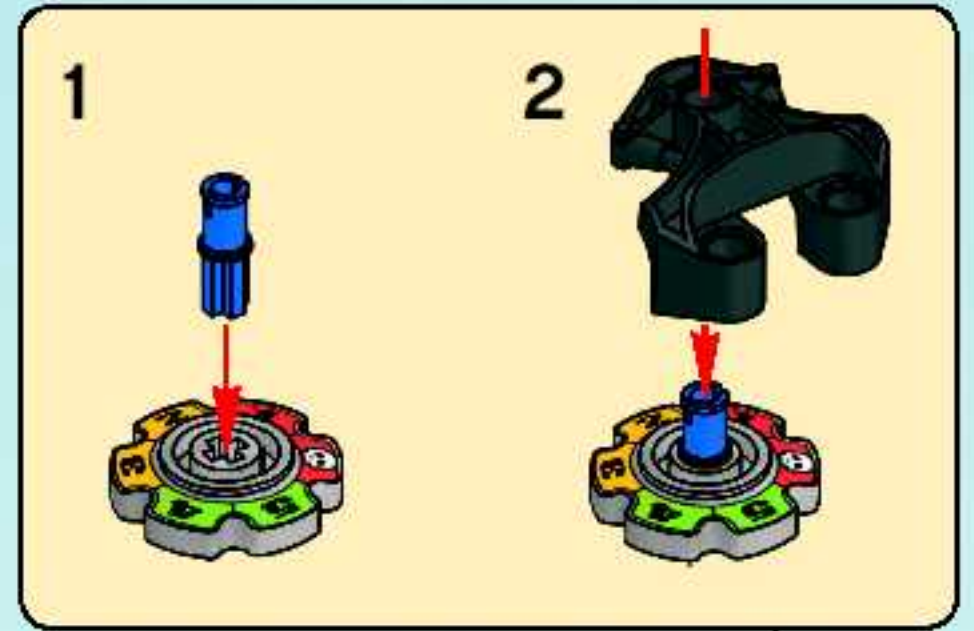
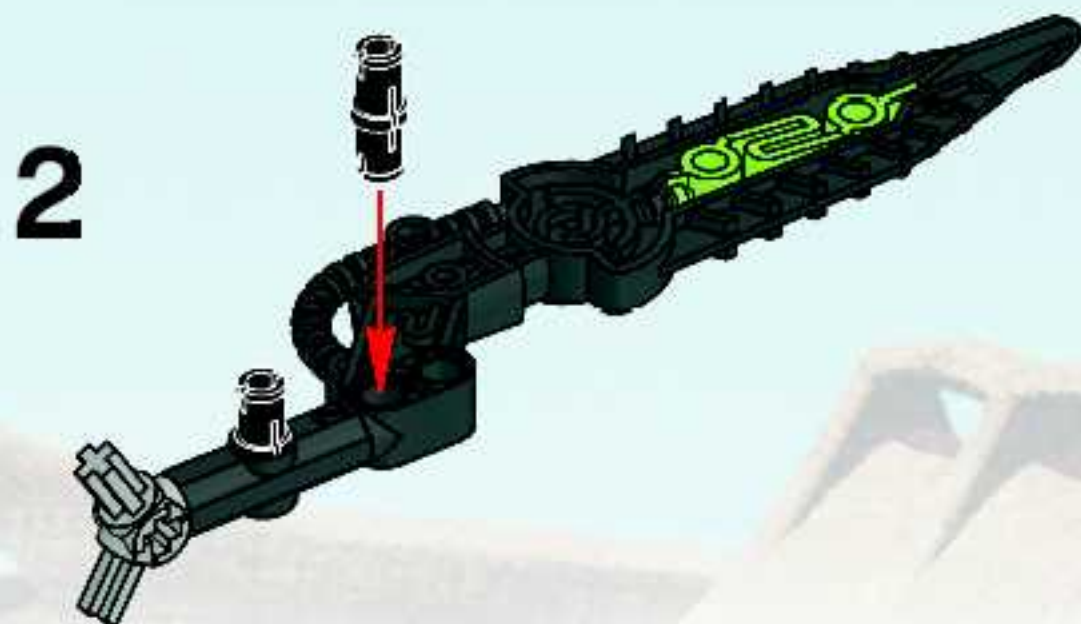
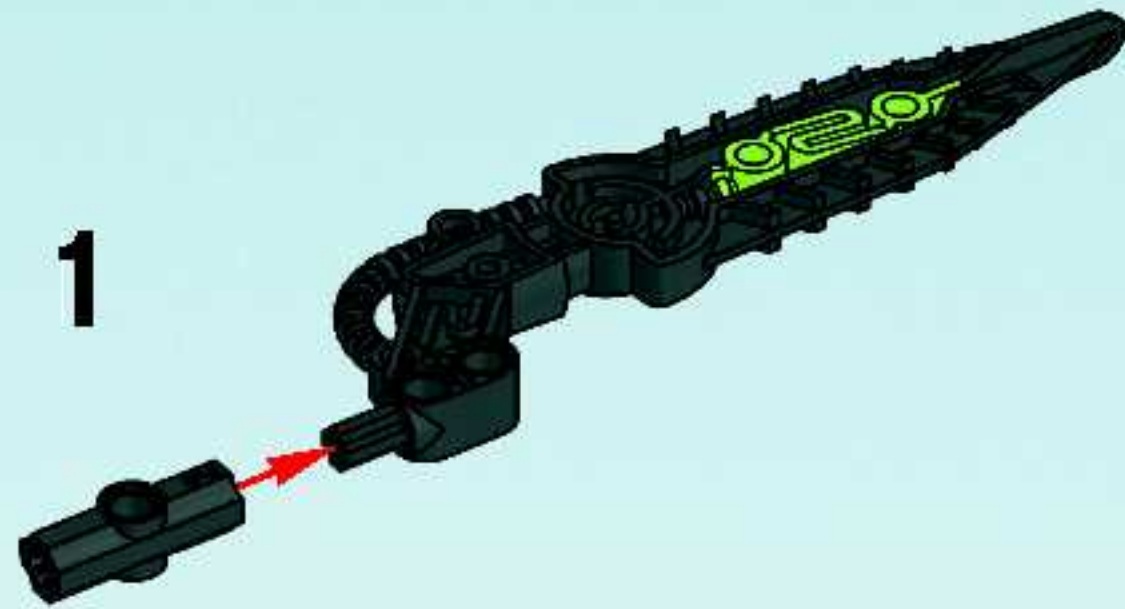

3





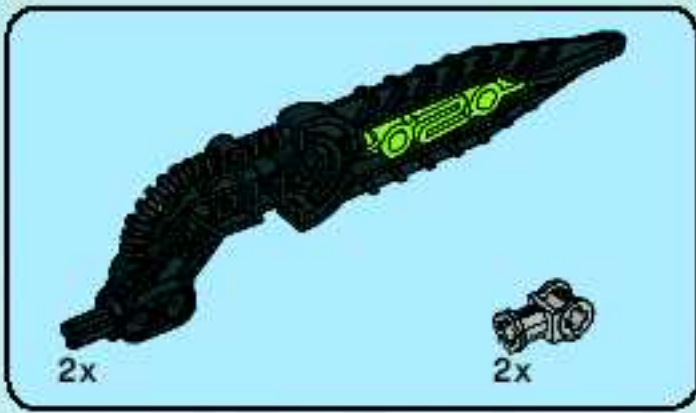

14





1x

15

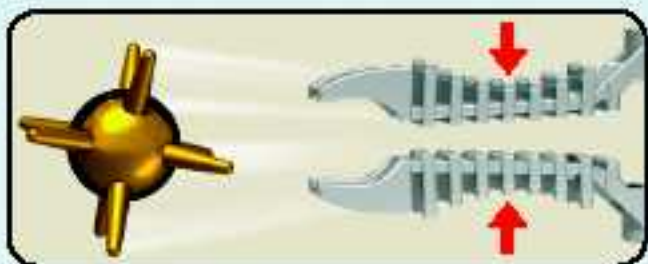
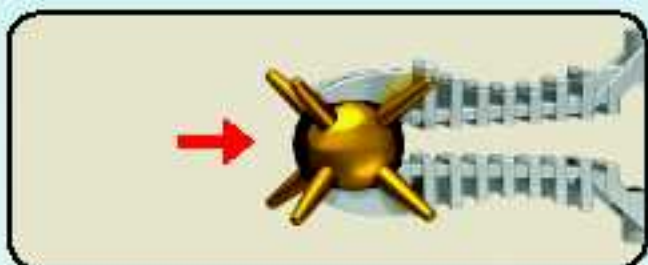

13x
4142865

18x
4206482

1x
4514553

2x
4537514

15x
4121715

6x
370526

1x
370626

4x
4121667

2x
4519243

4x
4505842

4x
4128557

2x
4286267

2x
4107783

1x
4278747

4x
4294582

1x
4278585

1x
4292590

3x
4540599

1x
4539552

1x
4284574

1x
4535771

4x
4107136

2x
4538946

1x
4539770

4x
4537504

2x
4539214

5x
4539420

2x
4539423

2x
4292598

14x
4211573

3x
4211865

2x
4502595

10x
4211553

2x
4211815

4x
4211639

2x
4211610

8x
4211566

1x
4540702

1x
4546585

4x
4289258

1x
4516546

2x
4515183

2x
4234599

9x
4519225

2x
4519229

1x
4210755

2x
4520068

2x
4499858

2x
4544529

2x
4494486

2x
4546416

Customer Service
Kundenservice
Service Consommateurs
Servicio Al Consumidor

www.lego.com/service or dial



: 00800 5346 5555

: 1-800-422-5346

8988

8981

8982

8976

8975

8990

8977

8980



8974

8979

8973

8978

8991

8972

For more rules on advanced multi-figure game play - check out

Pour plus d'information concernant les règles des jeux de niveau avancé avec plusieurs figurines, visitez

Para más información sobre instrucciones de juego avanzado con varias figuras, consulta

www.BIONICLE.com



8978

8979

8980



8981

8983

8982



8972



8973



8974

www.BIONICLE.com



8975



8977



8976

www.nielsen.com/LEGO



WIN LEGO® PRODUCTS

Fill out a survey and you might WIN a cool LEGO product!
NO PURCHASE NECESSARY
Open to all residents where not prohibited
Go to www.nielsen.com/LEGO to fill out a survey for a chance to win a LEGO product.

WIN LEGO® PRODUCTEN

Vul een enquêteformulier in en maak kans op een cool LEGO® product!
Kopen niet nodig
Iedereen uit landen waar geen enquêteverbod geldt mag deelnemen.
Ga naar www.nielsen.com/LEGO, vul een enquêteformulier in en maak kans op een LEGO product.

GEWINNE LEGO® PRODUKTE

Nimm an der Umfrage teil und GEWINNE ein tolles LEGO® Produkt!
Die Teilnahme am Gewinnspiel führt zu keinerlei Kaufverpflichtungen
Teilnahme in allen nicht ausgeschlossenen Ländern möglich
Wir verlosen unter allen Teilnehmern der Umfrage auf www.nielsen.com/LEGO LEGO Produkte.

GAGNE DES PRODUITS LEGO®

Répondre à un questionnaire et tu pourrais GAGNER un produit LEGO® très cool !
Aucune obligation d'achat.
Ouvert à tous les résidents des pays autorisés.
Visite www.nielsen.com/LEGO pour répondre à un questionnaire et avoir une chance de gagner un produit LEGO.

レゴ®製品を「当てよう」

アンケートに記入して、カッコいいレゴ®製品を当てよう！
お買い上げの必要はありません。
禁止されていない限り、すべての皆様にご利用いただけます。
www.nielsen.com/LEGOにアクセスして、アンケートにご記入ください。当選者にはレゴ®製品を差し上げます。



FREE! GRATIS! GRATUIT!



www.LEGOclub.com



00800 5346 5555*

1-866-534-6258 • 1-877-518-5346
US & Canada only Canada seulement

VISIT THE WORLD'S
BIGGEST LEGO® SHOP!

www.LEGOshop.com



www.LEGO.com

* Freephone. Mobile charges may apply. * Numéro sans Frais. Des Frais peuvent s'appliquer avec les téléphones cellulaires. * Gebührenfrei. Kosten für Anrufe aus Mobilfunknetzen können anfallen. * Gratis telefoonnummer van vaste lijn. * Het erelb gratisnummer, nór de ringer Pro Postbetaal. * Décor gratis, nór duringer Prín en Postbetaal.