



7789

Disney · PIXAR  
**TOY  
STORY**  
**3**



1

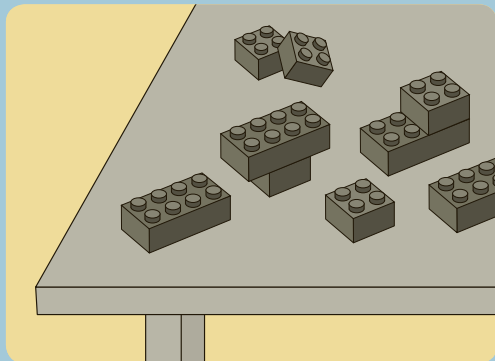
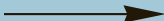
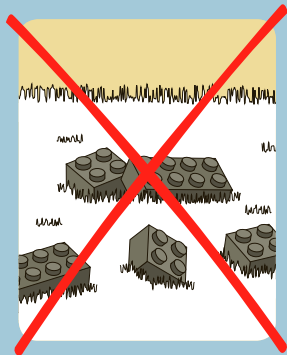

2

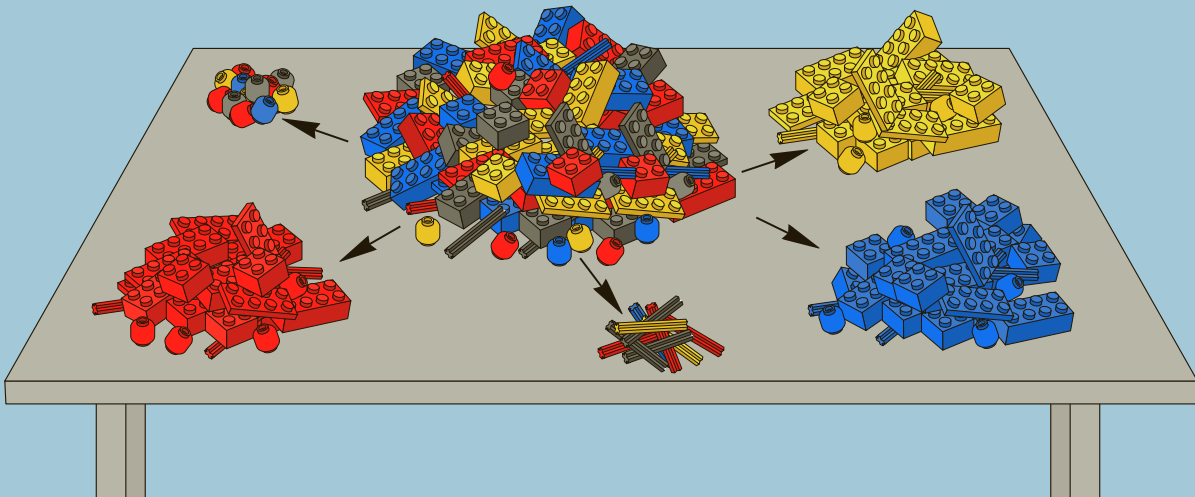

2

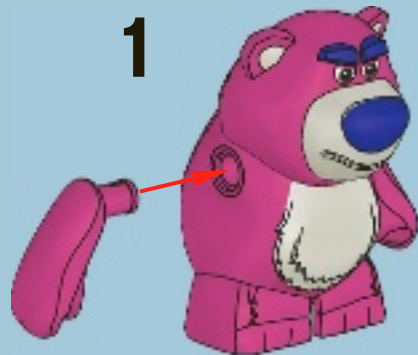
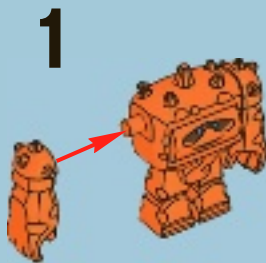
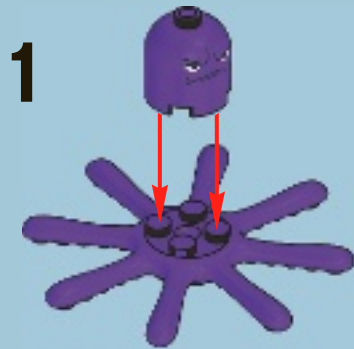

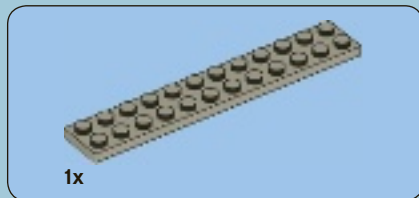

**1**

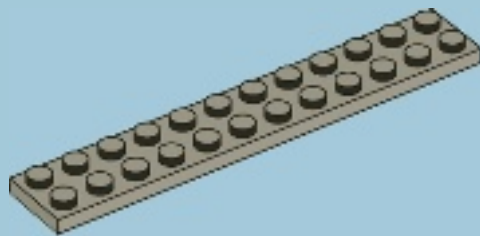

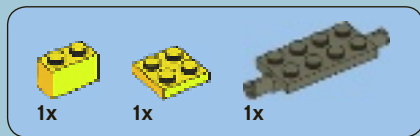

2

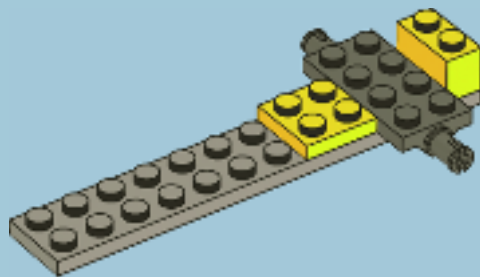

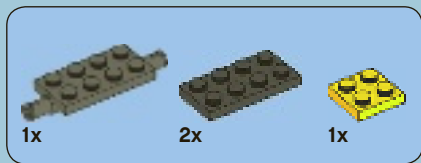

3

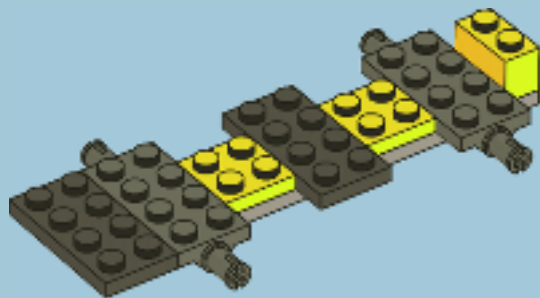



4

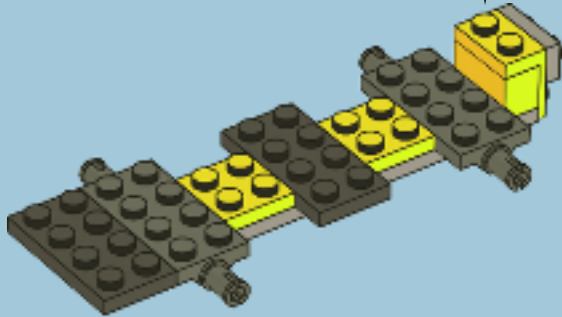
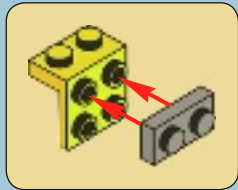



5

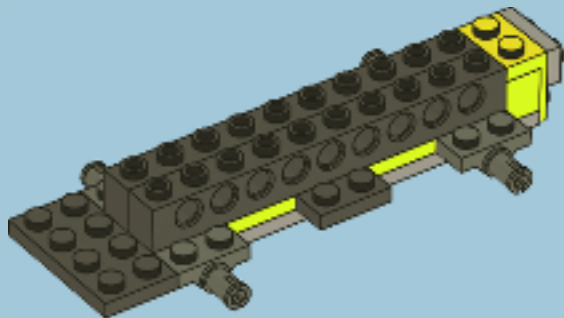

8





2x



2x

# 6

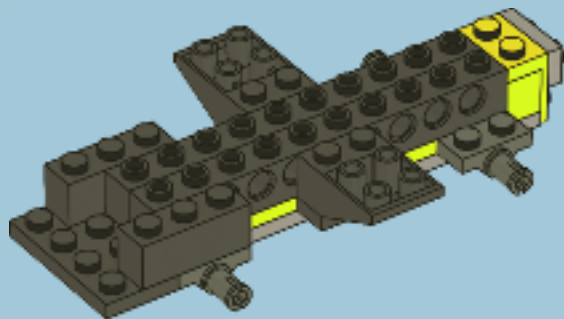



4x

7

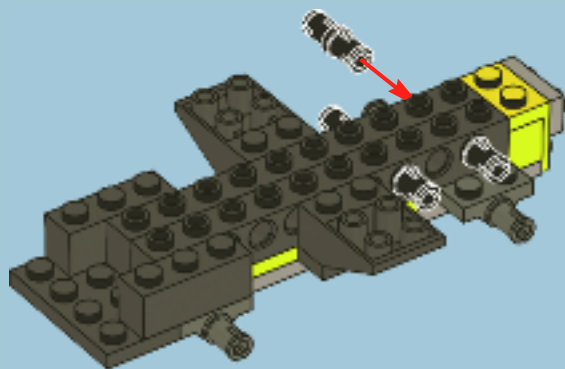

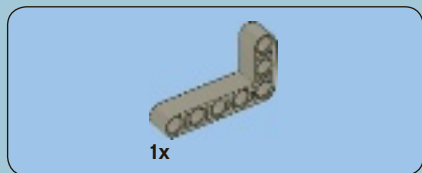

8

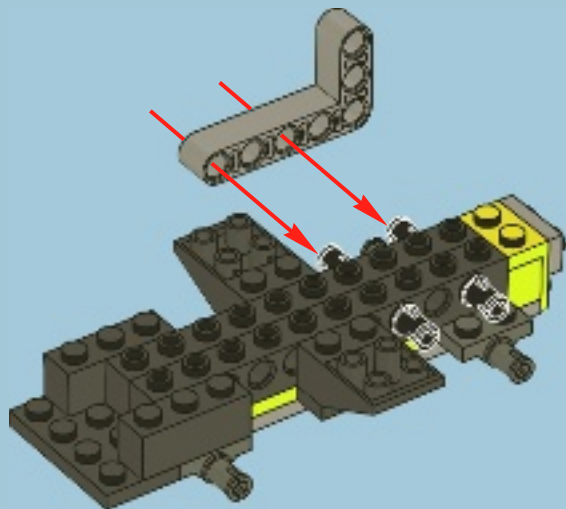



1x



1x



1x

9

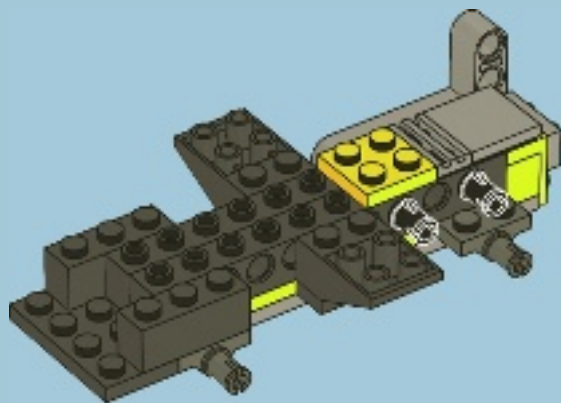

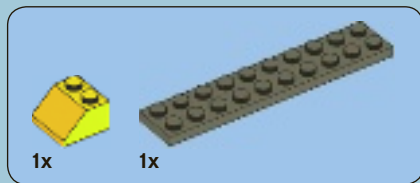

10

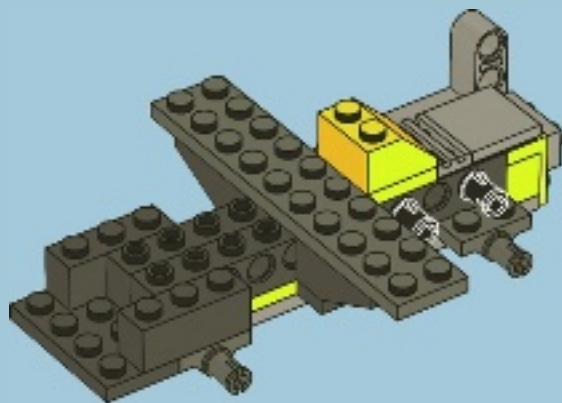



2x

# 11

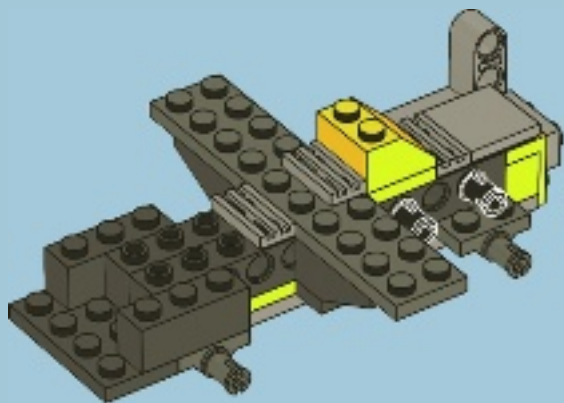

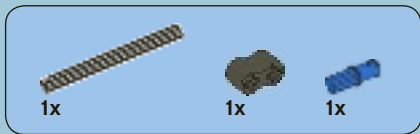

12

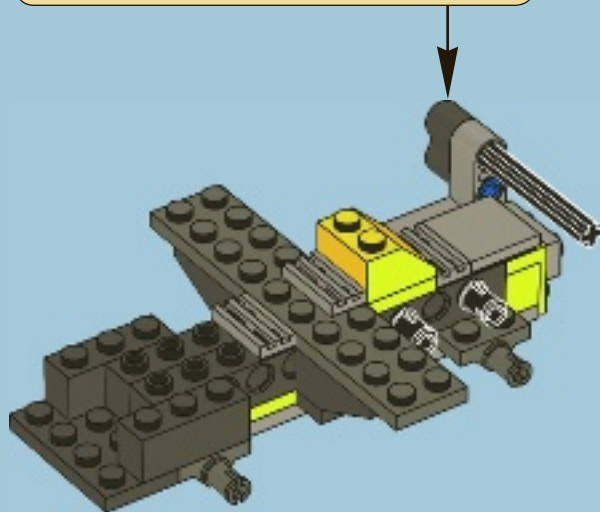
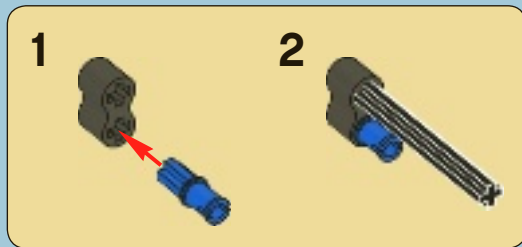

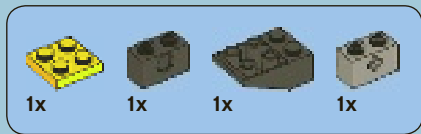

13

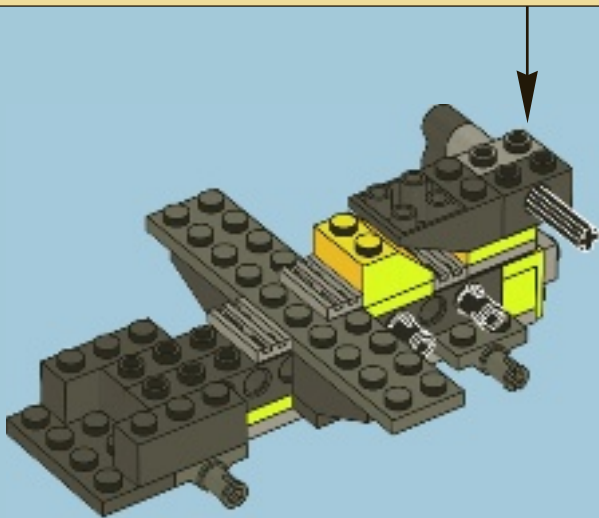
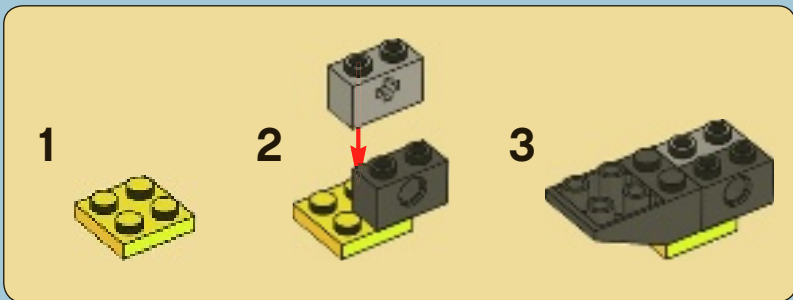



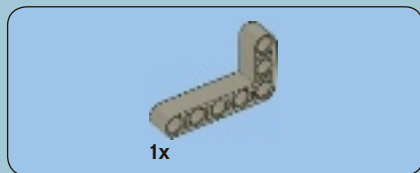

14

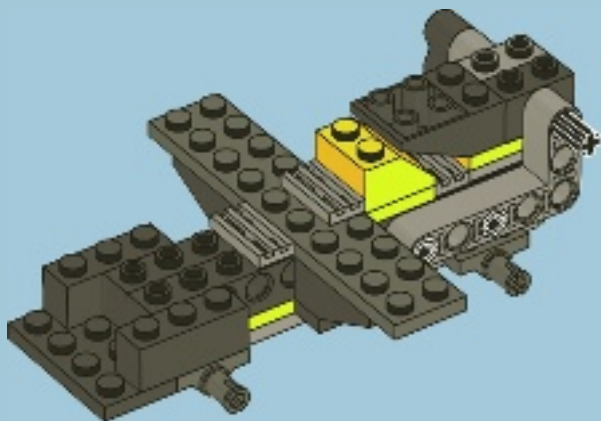



15

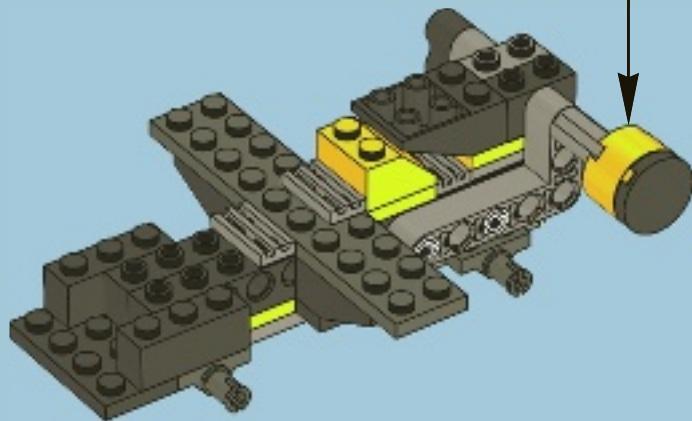
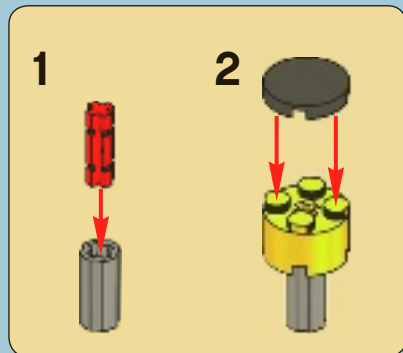



# 16

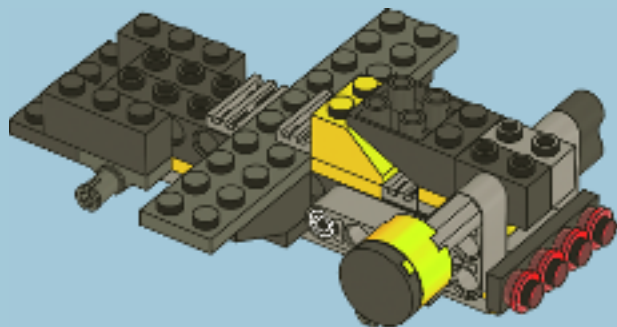



2x

# 17

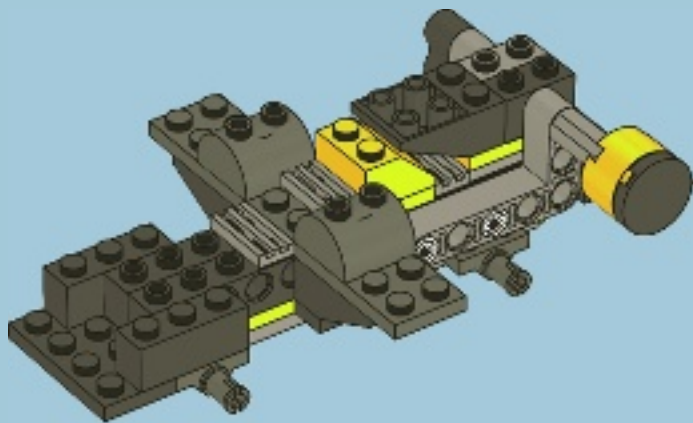



18

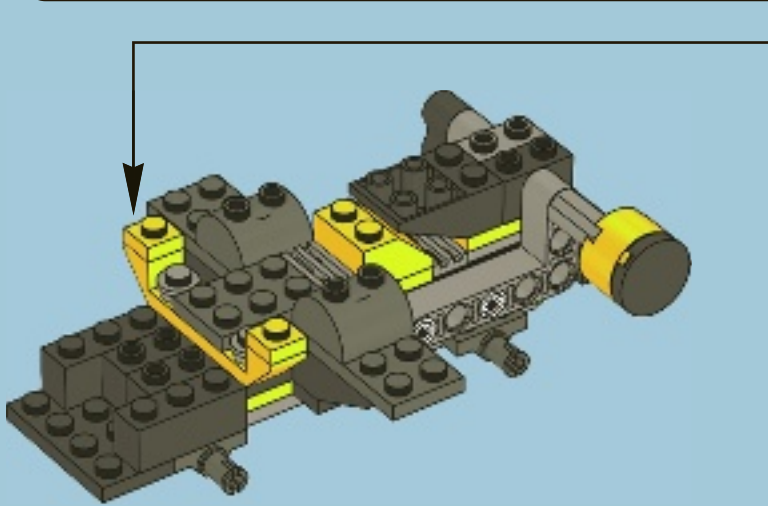
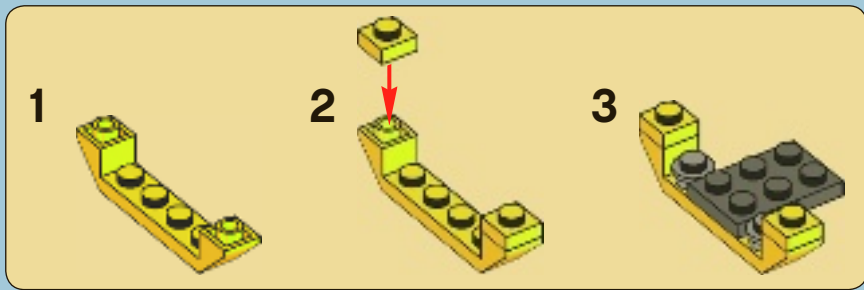



1x



1x

# 19

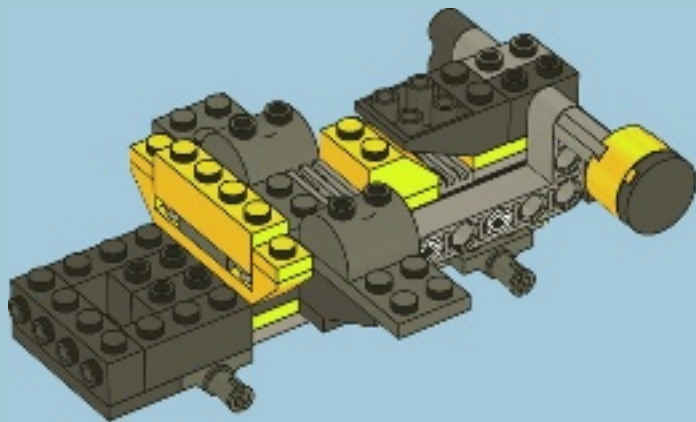

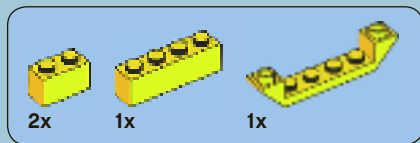

20

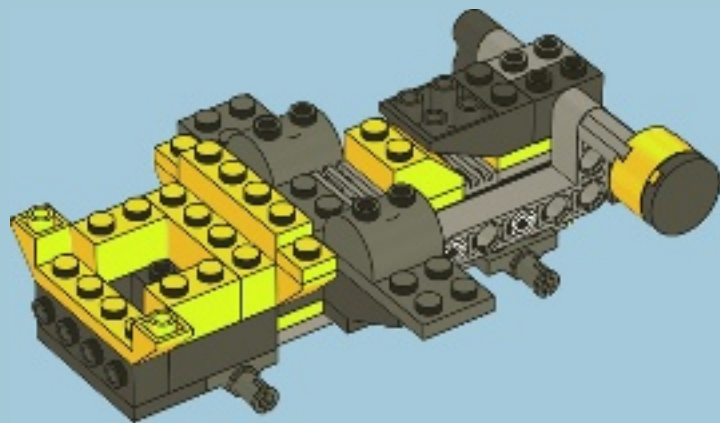



# 21

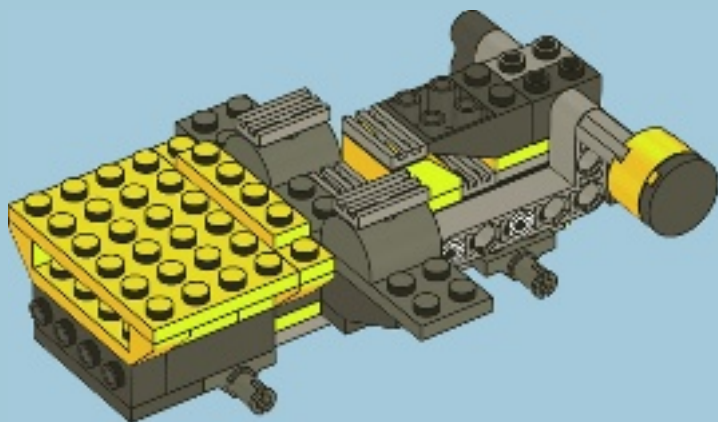





22

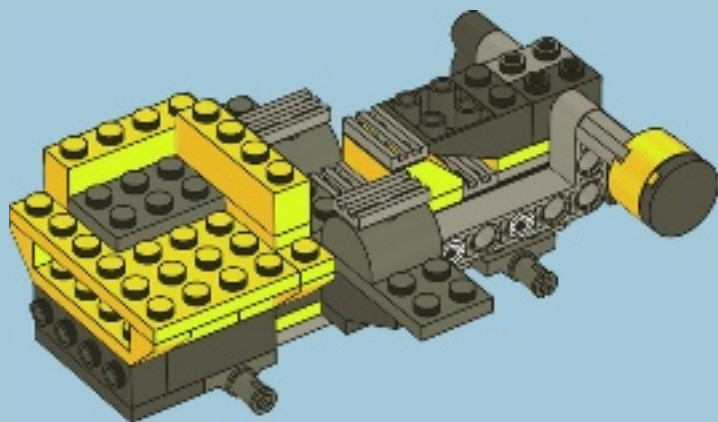



1x



1x

# 23

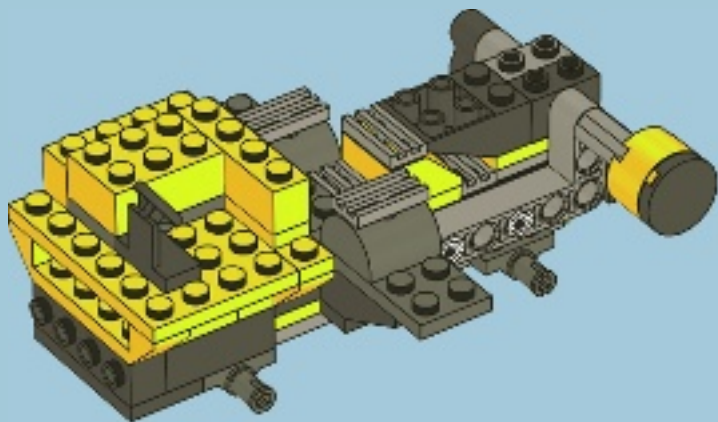

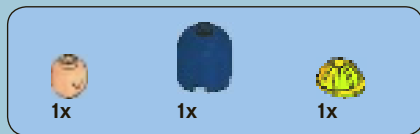

24

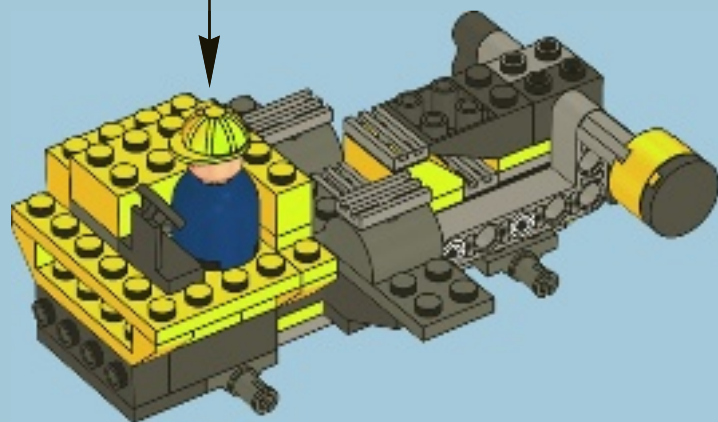
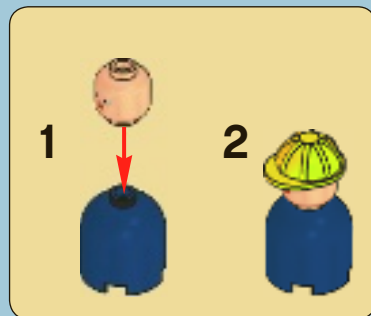



1x

# 25

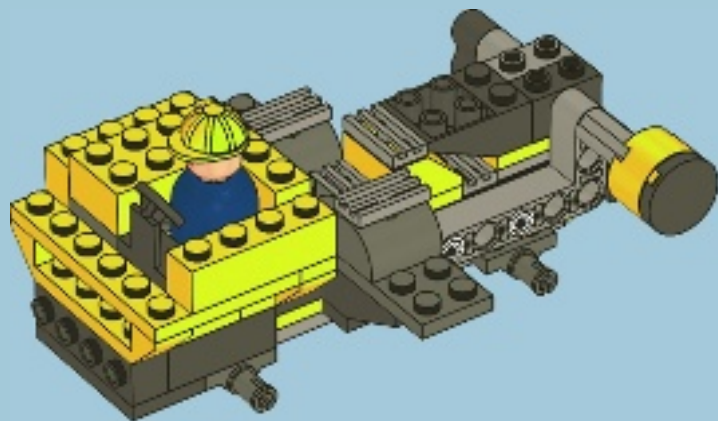



2x

# 26

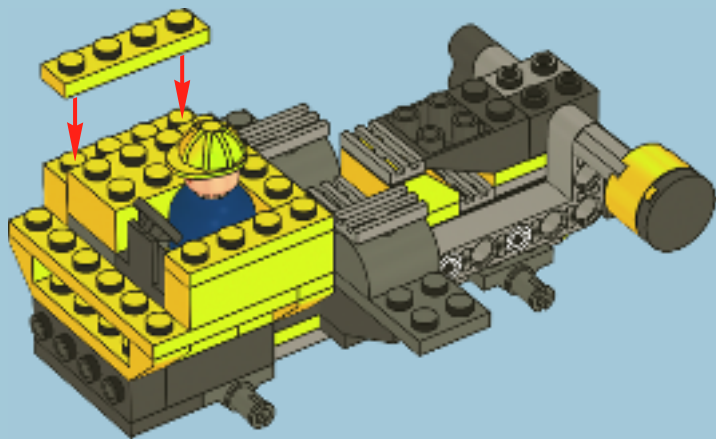

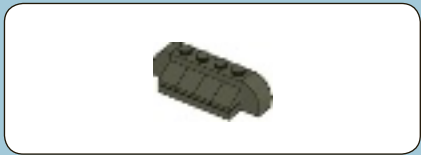

1

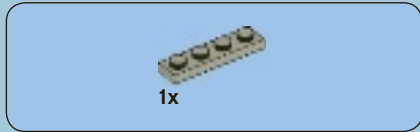

2

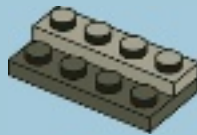



3

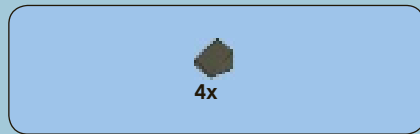
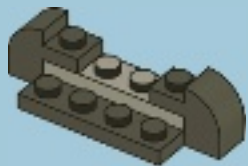

4

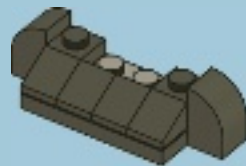



1x

5



27

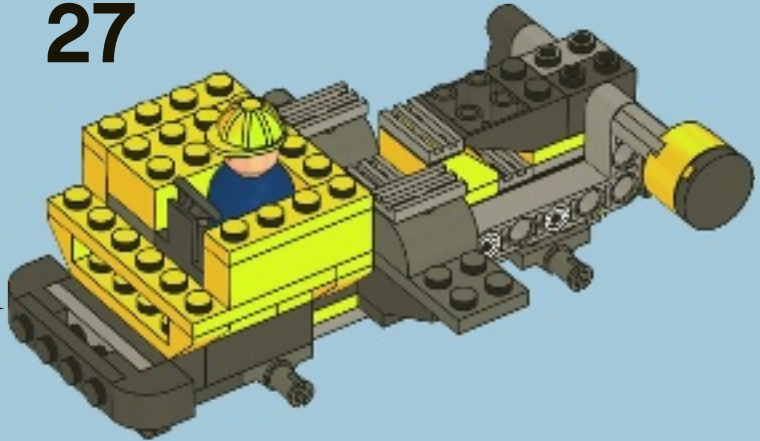





1x



2x

# 28

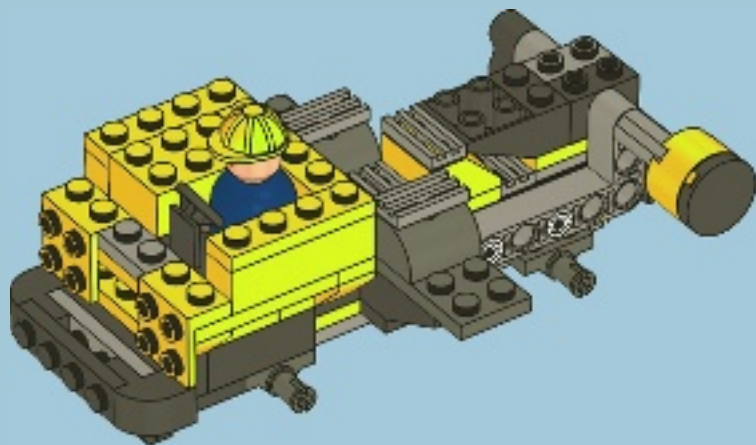

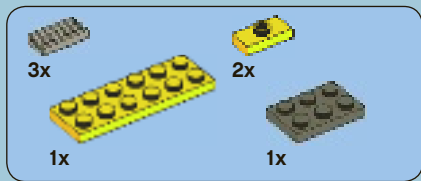

# 29

## 1

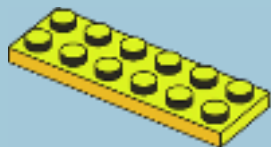

## 2

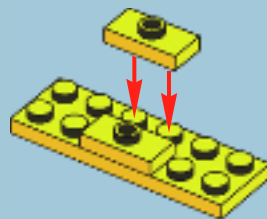

## 3

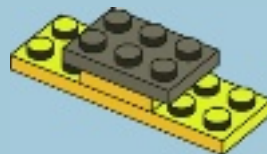

4

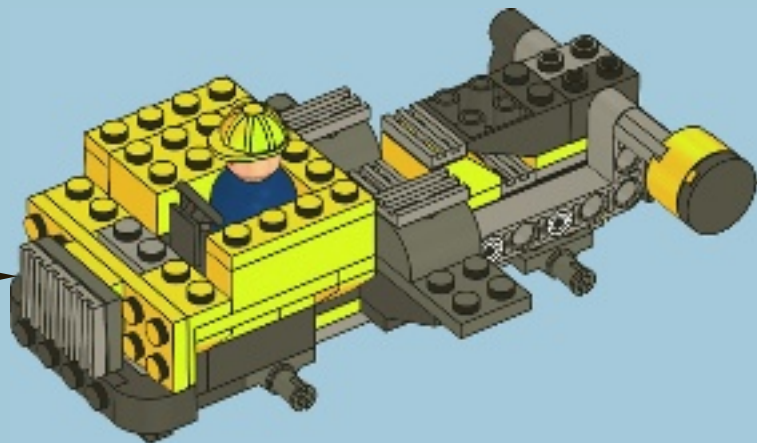
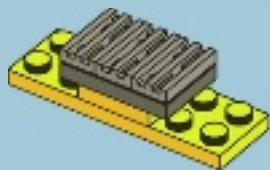



3x

# 30

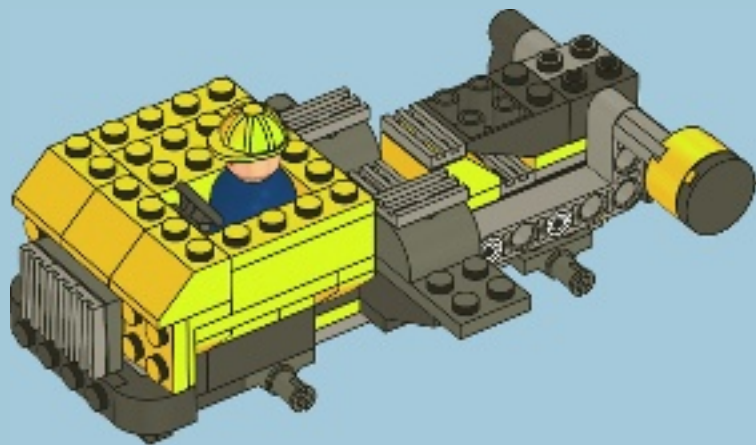

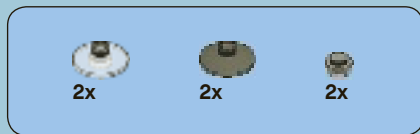

# 31

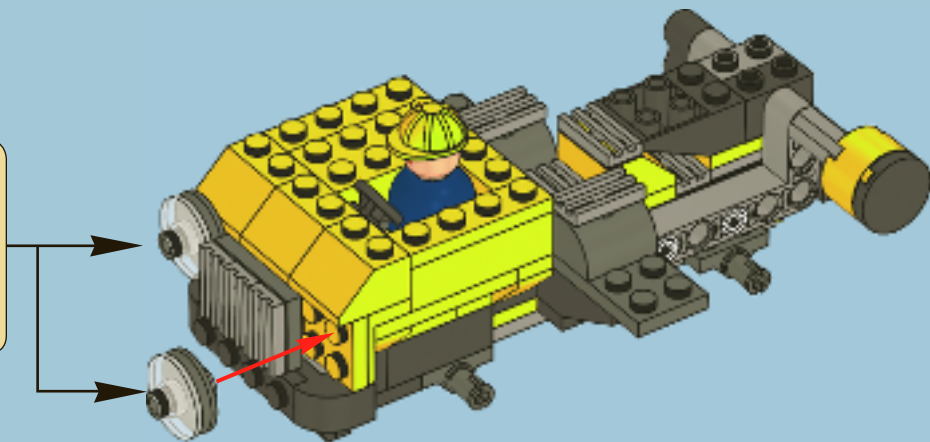



1x



1x

# 32

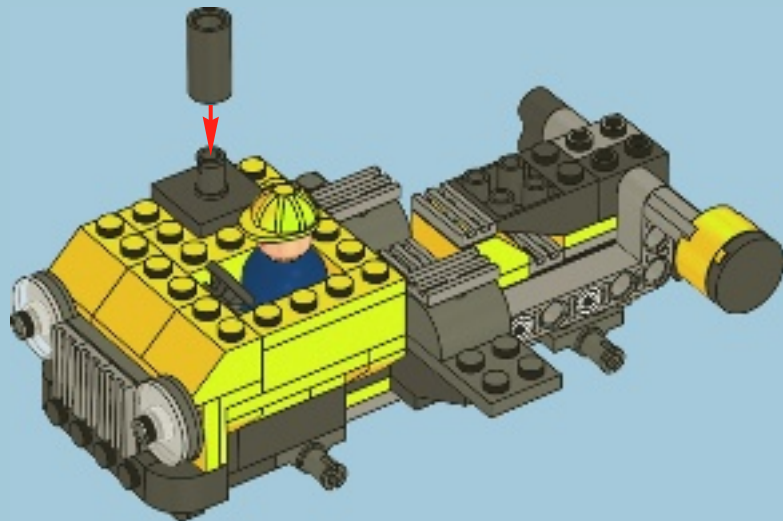



1x



2x

# 33

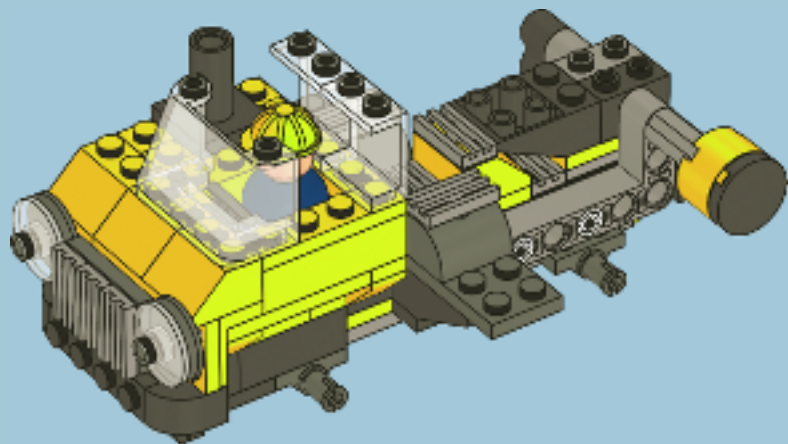



1x

# 34

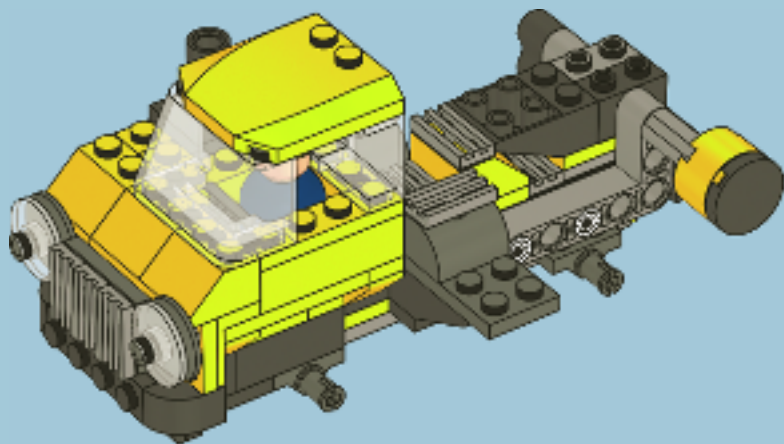



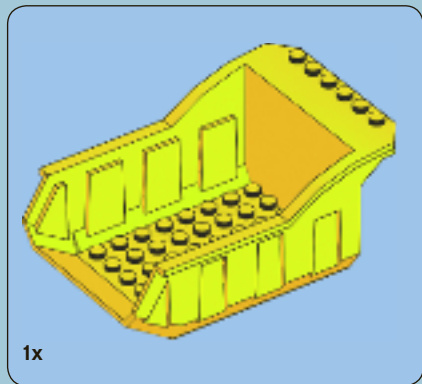

35

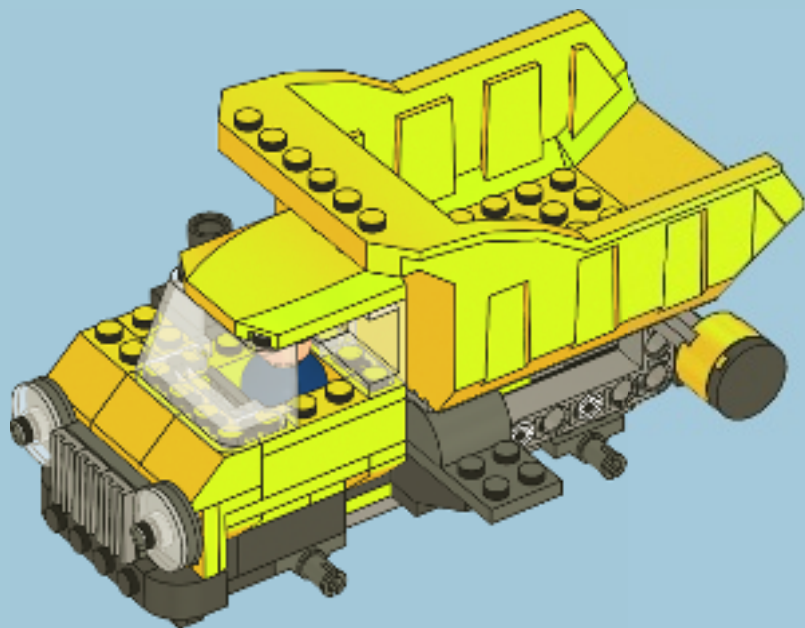

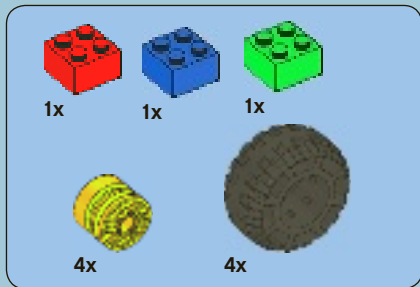

36

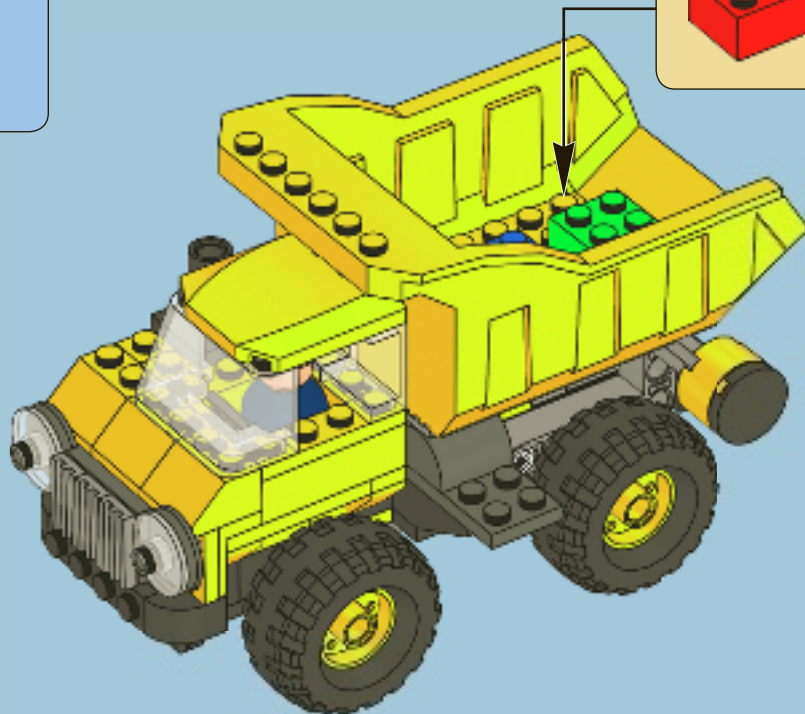
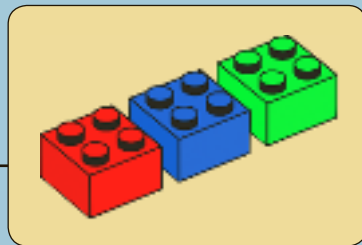





1x  
300321



1x  
4142865



1x  
300323



1x  
4206482



3x  
300424



1x  
300224



5x  
301024



1x  
614324



4x  
303924



2x  
4503844



2x  
302424



4x  
302224



2x  
371024



1x  
379524



1x  
303224



2x  
379424



3x  
4277925



4x  
4490142



1x  
4587557



1x  
4193073



2x  
362226



1x  
4162443



1x  
370026



4x  
4504382



3x  
374726



2x  
371026



3x  
302026



1x  
4258354



1x  
415026



4x  
4506553



1x  
73081



4x  
4121715



2x  
609126

1x  
4198367

1x  
4526982

1x  
370626

1x  
300328

1x  
4587556

1x  
4585375

2x  
4187750

2x  
4113028

4x  
3005741

1x  
382340

1x  
4262974

1x  
4233493

2x  
4211398

1x  
4211413

1x  
4211445

9x  
4211350

4x  
4211525

2x  
4211713

1x  
4512360

1x  
4210678

2x  
4211093

3x  
4211043

2x  
4509884

2x  
4211010

1x  
4587497

1x  
4583557

1x  
4583555

1x  
4583556

1x  
4584159

1x  
4596002

2x  
4595948

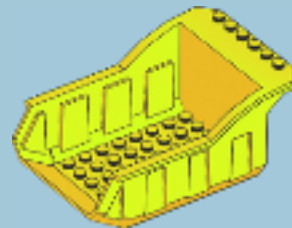

1x  
4582655

2x  
273026

1x  
4211360



Customer Service

Kundenservice

Service Consommateurs

Servicio Al Consumidor

[www.lego.com/service](http://www.lego.com/service) or dial



: 00800 5346 5555

: 1-800-422-5346



Disney · PIXAR  
**TOY  
STORY**

LEGO and the LEGO logo are trademarks of the LEGO group.  
©2010 The LEGO group.  
© Disney/Pixar.



**7596**



**7594**



**7597**



**7593**



**7590**



**LEGO.COM/TOYSTORY**

FREE! GRATIS! GRATUIT!



club  
MAGAZINE™

www.LEGOclub.com



00800 5346 5555\*



1-866-534-6258 • 1-877-518-5346

US & Canada only

Canada seulement

\* Freephone. Mobile charges may apply. \* Numéro sans Frais. Des Frais peuvent s'appliquer avec les téléphones cellulaires. \* Gebührenfrei, Kosten Für Anrufe aus Mobilfunknetzen können abweichen.  
\* Gratis telefoonnummer vanaf vaste lijn. \* Dit nr. et is gratis nummer, nlr du ringer Fra Posttelefon. \* Det är gratis, nlr du ringer från en Post telefon.



VISIT THE WORLD'S  
BIGGEST LEGO® SHOP!

www.LEGOshop.com



# WIN!

Go to [www.nielsen.com/LEGO](http://www.nielsen.com/LEGO)  
to fill out a survey for a chance  
to win a cool LEGO® Product.



[www.LEGO.com](http://www.LEGO.com)

No purchase necessary.

Open to all residents where not prohibited.



## [www.nielsen.com/LEGO](http://www.nielsen.com/LEGO)

### GEWINNE!

Nimm an der Umfrage auf [www.nielsen.com/](http://www.nielsen.com/) LEGO teil und hab die Chance ein cooles LEGO® Produkt zu gewinnen!  
Die Teilnahme am Gewinnspiel führt zu keinerlei Kaufverpflichtungen. Teilnahme in allen nicht ausgeschlossenen Ländern möglich.

### WIN!

Ga naar [www.nielsen.com/LEGO](http://www.nielsen.com/LEGO), vul een enquêteformulier in en maak kans op een cool LEGO® product.  
Geen aankoopverplichting.  
Iedereen mag deelnemen, uitgezonderd ingezetenden van landen waar een enquêteverbod geldt.

### GAGNE!

Visite [www.nielsen.com/LEGO](http://www.nielsen.com/LEGO) pour répondre à un questionnaire et avoir une chance de gagner un produit LEGO® très cool!  
Aucune obligation d'achat.  
Ouvert à tous les résidents des pays autorisés.

### 当てよう!

[www.nielsen.com/LEGO](http://www.nielsen.com/LEGO) にアクセスして、アンケートにご記入ください。  
当選者にはレゴ製品を差し上げます。  
お買い上げの必要はありません。  
禁止されていない限り、すべての皆様にご利用いただけます。