

INSTRUCTION MANUAL

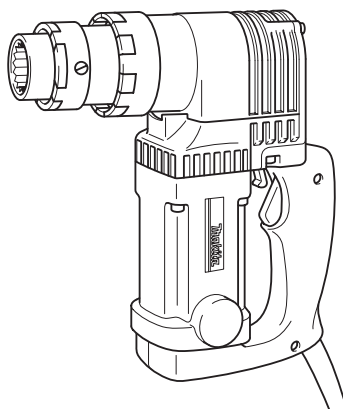

Shear Wrench

6922NB



DOUBLE INSULATION



Read before use.



SPECIFICATIONS

Model	6922NB
Bolt size	M16, M20, M22
Max. normal torque	803.6 N•m
No load speed (min ⁻¹)	18 or 20 (country specific)
Dimensions (L×W×H)	249 mm×84 mm×252 mm
Net weight	4.9 kg
Safety class	□/II

- Due to our continuing program of research and development, the specifications herein are subject to change without notice.
- Specifications may differ from country to country.
- Weight according to EPTA-Procedure 01/2014

Symbols

The following show the symbols used for the equipment. Be sure that you understand their meaning before use.

	Read instruction manual.
	DOUBLE INSULATION
	Only for EU countries Do not dispose of electric equipment together with household waste material! In observance of the European Directive, on Waste Electric and Electronic Equipment and its implementation in accordance with national law, electric equipment that have reached the end of their life must be collected separately and returned to an environmentally compatible recycling facility.

Intended use

The tool is intended for fastening "tor-shear type" high tensile bolts.

Power supply

The tool should be connected only to a power supply of the same voltage as indicated on the nameplate, and can only be operated on single-phase AC supply. They are double-insulated and can, therefore, also be used from sockets without earth wire.

General power tool safety warnings

⚠ WARNING: Read all safety warnings, instructions, illustrations and specifications provided with this power tool. Failure to follow all instructions listed below may result in electric shock, fire and/or serious injury.

Save all warnings and instructions for future reference.

The term "power tool" in the warnings refers to your mains-operated (corded) power tool or battery-operated (cordless) power tool.

Work area safety

1. **Keep work area clean and well lit.** Cluttered or dark areas invite accidents.
2. **Do not operate power tools in explosive atmospheres, such as in the presence of flammable liquids, gases or dust.** Power tools create sparks which may ignite the dust or fumes.

3. **Keep children and bystanders away while operating a power tool.** Distractions can cause you to lose control.

Electrical Safety

1. **Power tool plugs must match the outlet. Never modify the plug in any way. Do not use any adapter plugs with earthed (grounded) power tools.** Unmodified plugs and matching outlets will reduce risk of electric shock.
2. **Avoid body contact with earthed or grounded surfaces, such as pipes, radiators, ranges and refrigerators.** There is an increased risk of electric shock if your body is earthed or grounded.
3. **Do not expose power tools to rain or wet conditions.** Water entering a power tool will increase the risk of electric shock.
4. **Do not abuse the cord. Never use the cord for carrying, pulling or unplugging the power tool. Keep cord away from heat, oil, sharp edges or moving parts.** Damaged or entangled cords increase the risk of electric shock.
5. **When operating a power tool outdoors, use an extension cord suitable for outdoor use.** Use of a cord suitable for outdoor use reduces the risk of electric shock.
6. **If operating a power tool in a damp location is unavoidable, use a residual current device (RCD) protected supply.** Use of an RCD reduces the risk of electric shock.
7. **Use of power supply via an RCD with a rated residual current of 30 mA or less is always recommended.**
8. **Power tools can produce electromagnetic fields (EMF) that are not harmful to the user.** However, users of pacemakers and other similar medical devices should contact the maker of their device and/or doctor for advice before operating this power tool.
9. **Do not touch the power plug with wet hands.**
10. **If the cord is damaged, have it replaced by the manufacturer or his agent in order to avoid a safety hazard.**

Personal Safety

1. **Stay alert, watch what you are doing and use common sense when operating a power tool. Do not use a power tool while you are tired or under the influence of drugs, alcohol or medication.** A moment of inattention while operating power tools may result in serious personal injury.

2. **Use personal protective equipment. Always wear eye protection.** Protective equipment such as a dust mask, non-skid safety shoes, hard hat or hearing protection used for appropriate conditions will reduce personal injuries.
3. **Prevent unintentional starting. Ensure the switch is in the off-position before connecting to power source and/or battery pack, picking up or carrying the tool.** Carrying power tools with your finger on the switch or energising power tools that have the switch on invites accidents.
4. **Remove any adjusting key or wrench before turning the power tool on.** A wrench or a key left attached to a rotating part of the power tool may result in personal injury.
5. **Do not overreach. Keep proper footing and balance at all times.** This enables better control of the power tool in unexpected situations.
6. **Dress properly. Do not wear loose clothing or jewellery. Keep your hair and clothing away from moving parts.** Loose clothes, jewellery or long hair can be caught in moving parts.
7. **If devices are provided for the connection of dust extraction and collection facilities, ensure these are connected and properly used.** Use of dust collection can reduce dust-related hazards.
8. **Do not let familiarity gained from frequent use of tools allow you to become complacent and ignore tool safety principles.** A careless action can cause severe injury within a fraction of a second.
9. **Always wear protective goggles to protect your eyes from injury when using power tools. The goggles must comply with ANSI Z87.1 in the USA, EN 166 in Europe, or AS/NZS 1336 in Australia/New Zealand. In Australia/New Zealand, it is legally required to wear a face shield to protect your face, too.**
3. **Disconnect the plug from the power source and/or remove the battery pack, if detachable, from the power tool before making any adjustments, changing accessories, or storing power tools.** Such preventive safety measures reduce the risk of starting the power tool accidentally.
4. **Store idle power tools out of the reach of children and do not allow persons unfamiliar with the power tool or these instructions to operate the power tool.** Power tools are dangerous in the hands of untrained users.
5. **Maintain power tools and accessories. Check for misalignment or binding of moving parts, breakage of parts and any other condition that may affect the power tool's operation. If damaged, have the power tool repaired before use.** Many accidents are caused by poorly maintained power tools.
6. **Keep cutting tools sharp and clean.** Properly maintained cutting tools with sharp cutting edges are less likely to bind and are easier to control.
7. **Use the power tool, accessories and tool bits etc. in accordance with these instructions, taking into account the working conditions and the work to be performed.** Use of the power tool for operations different from those intended could result in a hazardous situation.
8. **Keep handles and grasping surfaces dry, clean and free from oil and grease.** Slippery handles and grasping surfaces do not allow for safe handling and control of the tool in unexpected situations.
9. **When using the tool, do not wear cloth work gloves which may be entangled.** The entanglement of cloth work gloves in the moving parts may result in personal injury.

Service

1. **Have your power tool serviced by a qualified repair person using only identical replacement parts.** This will ensure that the safety of the power tool is maintained.
2. **Follow instruction for lubricating and changing accessories.**

SHEAR WRENCH SAFETY RULES

1. **Hold the power tool by insulated gripping surfaces, when performing an operation where the fastener may contact hidden wiring or its own cord.** Fasteners contacting a "live" wire may make exposed metal parts of the power tool "live" and could give the operator an electric shock.
2. **Before using power tool, make sure that the outer sleeve smoothly turns by hand. When it does not smoothly turn, never use it and ask MAKITA Authorized Service Center for check and repair.**
3. **When sheared bolt tip falls without moving tip ejector (tip lever), never use it and ask MAKITA Authorized Service Center for check and repair.**
4. **Always be sure you maintain good balance and firm footing.**
Be sure no one is below when using the tool in high or elevated locations.
5. **Hold the tool firmly.**
6. **Use care and common sense when disposing of sheared bolt tips. Falling tips from high locations or scattered tips can cause severe injury.**

SAVE THESE INSTRUCTIONS.

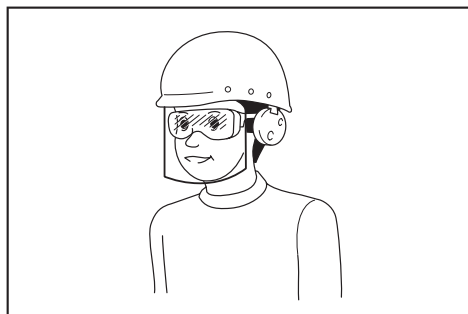

It is an employer's responsibility to enforce the use of appropriate safety protective equipments by the tool operators and by other persons in the immediate working area.

Power tool use and care

1. **Do not force the power tool. Use the correct power tool for your application.** The correct power tool will do the job better and safer at the rate for which it was designed.
2. **Do not use the power tool if the switch does not turn it on and off.** Any power tool that cannot be controlled with the switch is dangerous and must be repaired.

⚠WARNING: DO NOT let comfort or familiarity with product (gained from repeated use) replace strict adherence to shear wrench safety rules for the subject product. MISUSE or failure to follow the safety rules stated in this instruction manual may cause serious personal injury.

FUNCTIONAL DESCRIPTION

⚠CAUTION:

- Always be sure that the tool is switched off and unplugged before adjusting or checking function on the tool.

Switch action

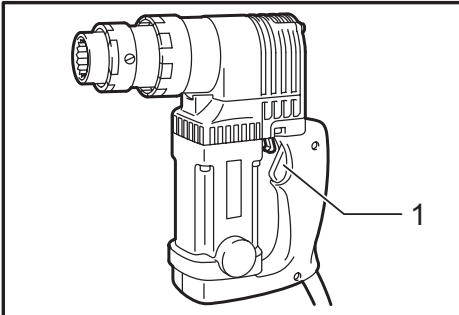

- 1. Switch trigger

⚠CAUTION:

- Before plugging in the tool, always check to see that the switch trigger actuates properly and returns to the "OFF" position when released.

To start the tool, simply pull the switch trigger. Release the switch trigger to stop.

ASSEMBLY

⚠CAUTION:

- Always be sure that the tool is switched off and unplugged before carrying out any work on the tool.

Removing the outer and inner sleeves

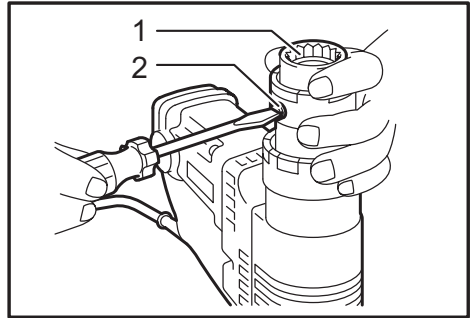

- 1. Outer sleeve 2. Screw

⚠CAUTION:

- Be careful not to allow foreign matter to enter the insides of the tool when removing or installing the outer and inner sleeves.

If you need, for your work, different sizes of outer sleeve and inner sleeve from those installed on your tool, replace the sleeves as follows.

Loosen the two screws while holding the outer sleeve. The outer and inner sleeves will be pushed up by the springs built into the tool. Press the pin down to remove the inner sleeve from the outer sleeve. Be careful not to drop the inner sleeve when removing it. Do not remove the inner sleeve spring, tip rod and tip rod spring from the tool.

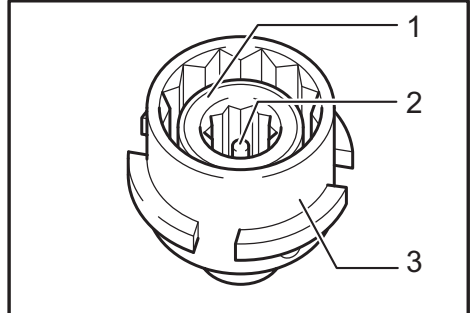

- 1. Inner sleeve 2. Pin 3. Outer sleeve

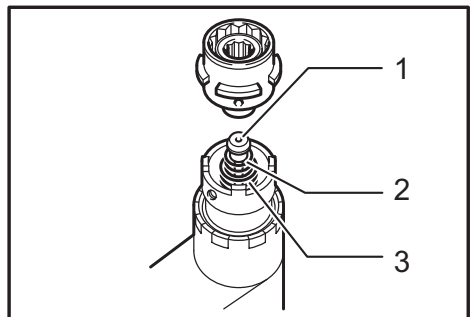

- 1. Tip rod 2. Tip rod spring 3. Inner sleeve spring

Installing the outer and inner sleeves

Hold the inner sleeve with the pin facing upward. Place the outer sleeve over the inner sleeve. Press the pin into the outer sleeve to allow inserting the inner sleeve, then release the pin to secure the inner sleeve.

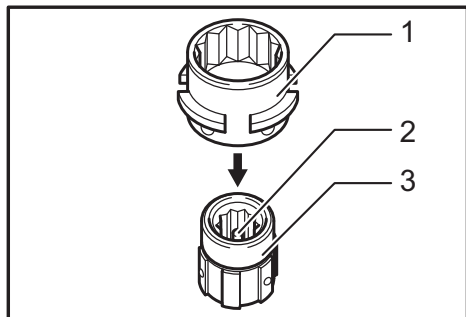

► 1. Outer sleeve 2. Pin 3. Inner sleeve

Insert the outer and inner sleeves into the tool while rotating the inner sleeve alternately clockwise and counterclockwise until there is no gap between the outer sleeve and the tool. See the figure. Then tighten the two screws securely.

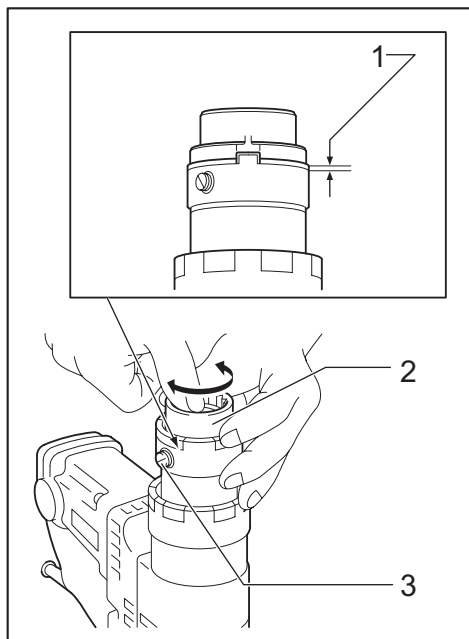

► 1. There should be no gap between the outer sleeve and the tool. 2. Outer sleeve 3. Screw

OPERATION

Bolt installation

Slip the tool onto the bolt so that the inner sleeve completely covers the bolt tip.

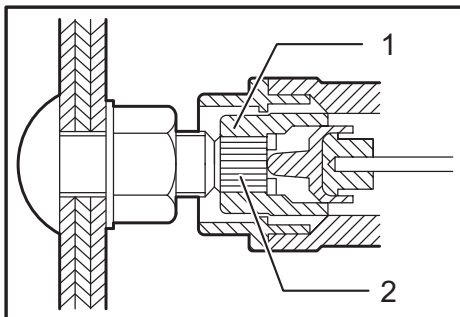

► 1. Inner sleeve 2. Bolt tip

CAUTION:

- Be careful when fitting the sleeve onto the bolt tip. Striking the tip can damage it so that it will no longer fit inside the sleeve properly.
- First tighten bolts preliminarily by using a hand wrench and then tighten them with this tool. Use this tool only after preliminary tightening without starting the tightening with this tool.

Keep forward pressure on the tool while sliding it further forward until the outer sleeve fits completely over the nut. If the tool fails to fit completely over the nut, twist the tool slightly right and left while pushing forward.

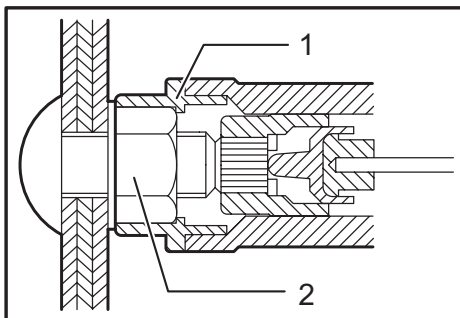

► 1. Outer sleeve 2. Nut

Pull the switch trigger. The outer sleeve turns to begin tightening the nut.

When the specified torque is attained, the bolt tip will be sheared at its notched portion. The bolt tip will remain inside the inner sleeve.

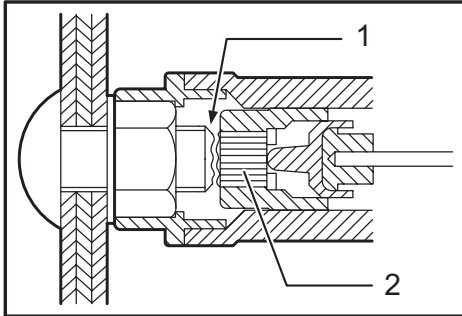

► 1. Notched portion 2. Bolt tip

Release the switch trigger and withdraw the tool in a straight line.

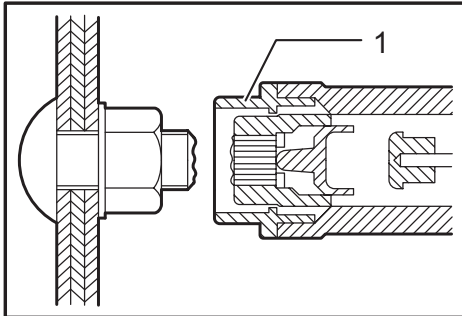

► 1. Outer sleeve

CAUTION:

- Do not force the tool down excessively. Apply the downward force to the degree just needed to hold the tool firm.

Pull the tip ejector (tip lever) to eject the bolt tip from the tool. Catch the sheared bolt tips to prevent them from falling dangerously below. Keep the tips off of the ground, floor, walkways, etc. to prevent injury from tripping or falling.

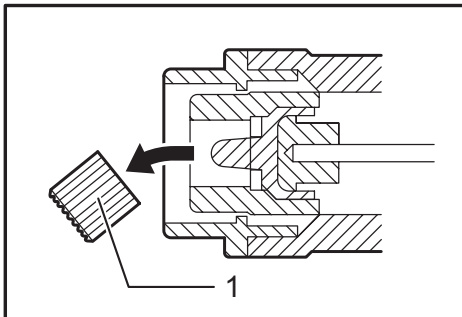

► 1. Bolt tip

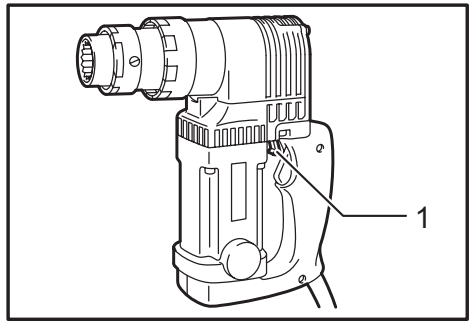

► 1. Tip ejector (Tip lever)

CAUTION:

- Washer and nut have head and tail. Head has identification mark for nut and chamfer for washer. When placing them, be careful not to place in reverse.

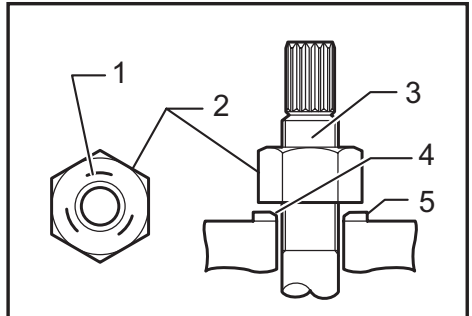

► 1. Identification mark 2. Nut 3. Bolt 4. Chamfered 5. Washer

CAUTION:

- Replace nut, bolt and washer all together at one time when these rotate together, nut rotates excessively or a bolt protrude from nut surface too much or less.
- Do not reuse used nut, bolt and washer.
- Choose shear bolts according to the thickness of workpiece to be fastened. Range for the remaining length of bolts that are obtained after cutting off chips are determined by bolt size. Refer to the table below for details.

Bolt size	Maximum remainig length	Minimum remainig length
M16	20mm	4.5mm
M20	15mm	5.5mm
M22	14mm	7mm

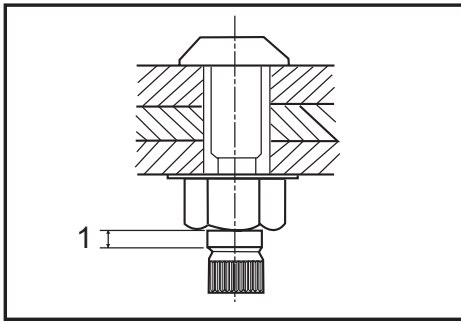

► 1. Remaining length

CAUTION:

- Use bolts with the remaining length within the range shown in the table above as bolts with different size have different maximum and minimum remaining length. Be careful not to use bolts beyond the specified range which causes the tool damage

Open the protector. Use a screwdriver to remove the brush holder caps. Take out the worn carbon brushes, insert the new ones and secure the brush holder caps.

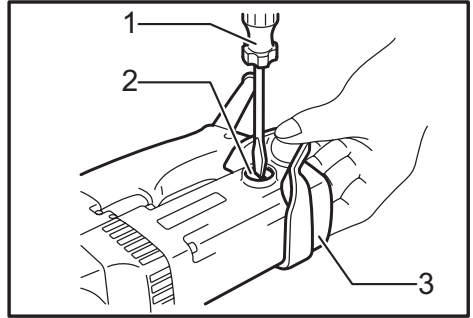

► 1. Screwdriver 2. Brush holder cap 3. Protector

To maintain product SAFETY and RELIABILITY, repairs, any other maintenance or adjustment should be performed by Makita Authorized Service Centers, always using Makita replacement parts.

MAINTENANCE

CAUTION:

- Always be sure that the tool is switched off and unplugged before attempting to perform inspection or maintenance.
- Never use gasoline, benzene, thinner, alcohol or the like. Discoloration, deformation or cracks may result.

Replacing carbon brushes

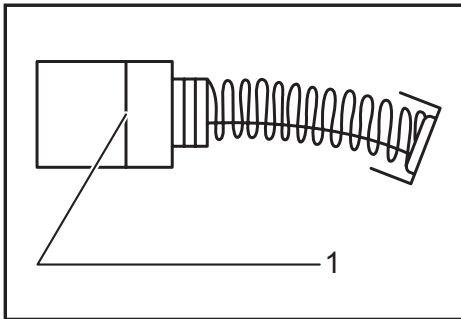

► 1. Limit mark

Remove and check the carbon brushes regularly. Replace when they wear down to the limit mark. Keep the carbon brushes clean and free to slip in the holders. Both carbon brushes should be replaced at the same time. Use only identical carbon brushes.

OPTIONAL ACCESSORIES

CAUTION:

- These accessories or attachments are recommended for use with your Makita tool specified in this manual. The use of any other accessories or attachments might present a risk of injury to persons. Only use accessory or attachment for its stated purpose.

If you need any assistance for more details regarding these accessories, ask your local Makita Service Center.

Sleeve	Bolt size	Length (mm)
Outer sleeve	M16	35
Inner sleeve	M16	36
Outer sleeve	M20	37
Inner sleeve	M20	38
Outer sleeve	M22	39
Inner sleeve	M22	39
Outer sleeve	M22	85
Inner sleeve	M22	85
Outer sleeve	5/8"	35
Inner sleeve	5/8"	36
Outer sleeve	3/4"	37
Inner sleeve	3/4"	38
Outer sleeve	3/4"	83
Inner sleeve	3/4"	84

NOTE:

- Some items in the list may be included in the tool package as standard accessories. They may differ from country to country.

Makita Corporation

www.makita.com

883878D4
EN
20171227