

Technical BULLETIN

© 2002 YAMAHA MOTOR CORPORATION, U.S.A.

2002 SXV700G; SXV700ERG SXViper Suspension Tuning for Softer Ride



INTRODUCTION

Symptom: Some SXViper owners reported last season that their suspension was too stiff and did not meet their expectations for ride comfort.

Remedy: A letter was sent to customers earlier this summer regarding SXViper suspension. A copy of this letter is reprinted on the last page of this bulletin.

- For some owners, the remedy may simply be proper adjustment of their stock suspension. In some cases, incorrect adjustments were made to suspension settings so the ride was stiffer rather than softer. This bulletin provides information about adjusting the stock suspension settings to soften the ride.
- For owners who are not satisfied with properly adjusted suspension, a 2002 SXViper Suspension Kit is available that has new front, center, and rear shock assemblies calibrated to provide a softer ride with more suspension compliance, especially over smaller bumps. The customer can purchase this kit at a special low trade-in price. Yamaha will reimburse you for installing the kit. This bulletin provides instructions for ordering and installing the kit if the customer chooses to purchase it.



DEALER ACTION SUMMARY

Inspect and Adjust:

Check the suspension settings according to the Stock Suspension Adjustment instructions in this bulletin to be sure the suspension was not adjusted incorrectly, which could cause an abnormally harsh ride. If the customer feels the suspension performed well, but was slightly stiff in smaller bumps or at slower speeds, proper stock suspension adjustment may be all that is necessary.

Modify: If the customer felt that the ride was much too stiff or harsh, adjustments to the stock suspension will probably not provide the kind of ride the customer wants. The customer can trade-in the stock suspension components for the new 2002 SXViper Suspension Kit for only \$189.00. The customer should understand that the softer suspension will bottom harder or more frequently in some conditions. Install the Suspension Kit according to the instructions in this bulletin if the customer purchases it.

Parts

Required: Order one kit for each customer who wants to purchase one. Some kits are available now, and greater quantities will be available in the fall. Order only as many kits now as you need for customers who want to have the kit installed early.

Warranty: Stock suspension adjustments are normal maintenance and therefore not covered by warranty. If the customer chooses to trade in stock suspension components for the new suspension components, submit a claim for the labor plus an amount for parts handling as described in this bulletin. The customer is responsible for the \$189.00 trade-in cost of the 2002 SXViper Suspension Kit plus applicable tax.



AFFECTED RANGE

Any 2002 SXViper or SXViperER with a customer complaint of a stiff or harsh suspension.



SERVICE PROCEDURES

Stock Suspension Adjustment

Perform the following procedure to adjust the stock suspension for the softest ride possible:

1. **Confirm all suspension settings are stock.** Refer to the 2002 Snowmobile Technical Update Seminar Manual (LIT-12468-00-02) to confirm standard settings for spring preload, full rate adjuster, control rod gap, and limiter strap settings.
2. **Check the position of the control rod sliding joint with the weight of the rider on the machine.** Standard suspension settings usually position the sliding joint near the middle, with approximately equal gap on top and bottom (see illustration A below). This provides a good balance of ride comfort, bump capability and handling, but may still feel too stiff for some customers. **For maximum ride comfort, the upper gap should be larger than the lower gap at an approximate 75/25 ratio with the rider sitting on the machine (see illustration B on top of next column).**

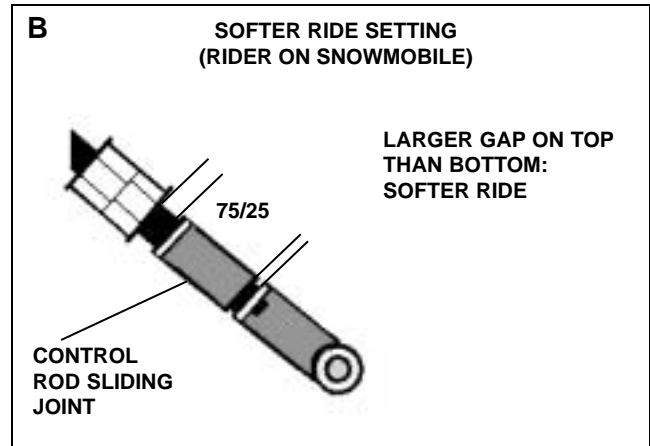
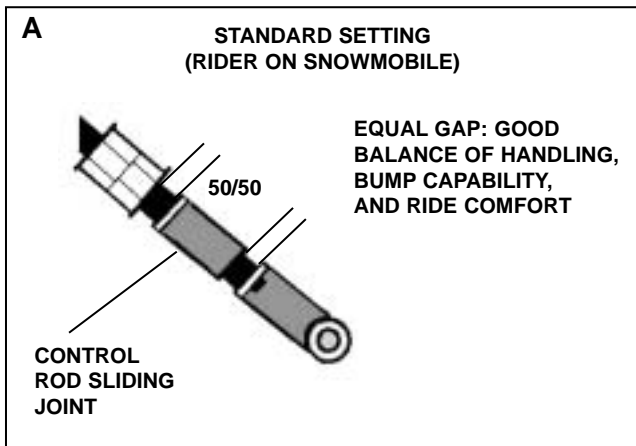

3. Adjust the rear suspension so the sliding joint is closer to the bottom than the top (e.g., larger gap at the top). First move the Full Rate Adjuster to a stiffer position. If this is not sufficient, increase rear shock spring preload by turning the threaded adjusters to compress the spring. Do not increase spring preload more than 10mm from stock.

If these adjustments do not position the sliding joint to the correct gap, or do not soften the suspension enough for the customer, the customer should consider purchasing the SXViper Suspension Kit.

2002 SXViper Suspension Kit Installation

Perform the following procedure if the customer wants to trade-in the stock suspension:

1. Remove the original equipment shock assemblies and replace them with the shock assemblies supplied in the kit. At first, do not make any changes to the shock spring preload settings.
2. Remove the 2.5mm lower control rod plastic spacers and install the 5mm spacers supplied in the kit. Move the control rod threaded adjusters upwards to increase the upper control rod gap to 16mm **without the weight of the rider on the machine (see illustration C below)**.

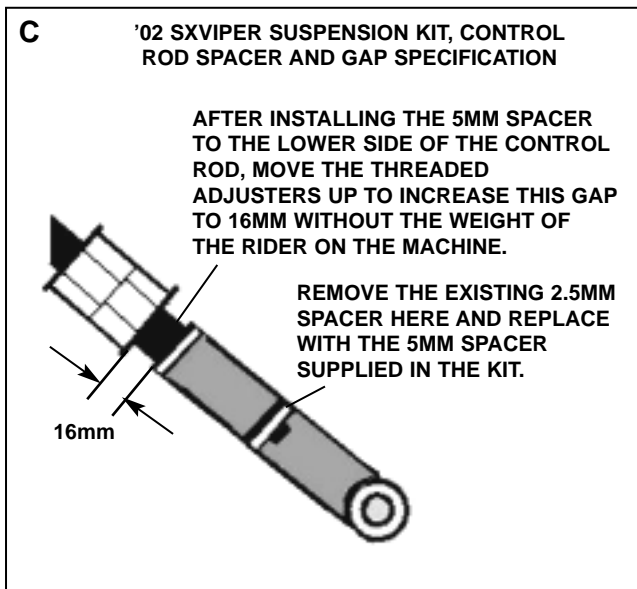

Once the complete kit has been installed, have the customer sit on the seat and check the control rod gap. If the gap is 50/50 or larger at the top, no adjustment is necessary. If not (gap larger at bottom), increase the rear shock spring preload to achieve the proper control rod gap.

NOTE: The suspension settings provided in this kit provide a softer ride for the SXViper and should satisfy most customers with stiff suspension complaints. Some customers may notice, because of a softer calibration, the suspension will bottom harder or more frequently in some conditions. It is important to understand that one suspension setting will not match every customer's riding styles and conditions. Some customers may require additional tuning or optional parts to achieve their desired suspension settings. Further suspension tuning information may be found by referring to the Suspension Tuning Manual and Video (P/N: VID-10660-00-73). Any further cost for suspension tuning for individual preferences will be the responsibility of the customer.

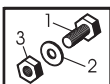

PARTS INFORMATION

Part Number	Description	Qty.	Dealer Cost	Trade-in Program Retail Cost
8FB-SHOCK-KT-00	2002 SXViper Suspension Kit	1	\$189.00	\$189.00



WARRANTY INFORMATION

The customer is responsible for the cost of the kit. To receive credit for the labor and \$25.00 parts handling reimbursement after completion, submit a Service Per Bulletin Warranty Claim using Problem Code **90RR**. The labor allowance for this installation is **1.2 hrs**. Tag and hold the original shocks for 90 days from the date you submit the warranty claim.



YAMAHA MOTOR CORPORATION, U.S.A.

8555 KATELLA AVENUE, CYPRESS, CALIFORNIA 90630-5101 714/761-7300 FAX 714/761-7302

May 31, 2002

Dear Yamaha Customer,

Thank you for buying your Yamaha SXViper or SXViper ER snowmobile.

The 2002 SXVipers are high-performance snowmobiles calibrated for aggressive "big-bump" trail riding. However, our customer satisfaction research has found that some owners thought the aggressive suspension was too stiff.

If you were not happy with the ride quality on your SXViper, please be aware that the suspension is adjustable. Incorrect adjustments, however, can make the ride stiffer. Check with your dealer to be sure your snowmobile is properly adjusted to suit your weight and riding style.

If your SXViper's suspension still does not provide the soft ride you prefer, you will be pleased to know that Yamaha will have a special softer suspension package available. The package can be purchased for \$189.00, and will be installed free by your dealer.

You are a valued Yamaha customer and we want to thank you again for purchasing a SXViper. If you have any additional questions regarding your Yamaha snowmobile, please contact Yamaha Customer Relations toll-free at 1-800-656-7695.

Sincerely,

A handwritten signature in cursive script that reads "Ron Leming".

Ron Leming
Manager
Technical Service Department