

**Disability Systems, Inc.**  
**1-877-258-7423**  
**www.disabilitysystems.com**

## TOOL LIST

### Required Tools:

- Reciprocating Saw with Metal Cutting Blade
- Drill
- 7/16" Drill Bit for Metal Drilling
- 1/4" Drill Bit for Wood Drilling
- 9/16" Standard Socket with Extension
- Ratchet Handle for 9/16" Socket
- Socket Adapter Bit for Drill lif using drill to drive socket
- 9/16" Standard Wrench
- 5/16" Hex Head Driver Bit
- 3/16" Allen Wrench
- 3" C-Clamp (minimum)
- Tape Measure
- 4' Level

### Recommended Tools:

- Cordless Drill
- Extension Cords
- 9/16" Deep Well Socket
- Magnetic 5/16" Hex Head Driver Bit
- Vice-Grip style C-Clamps
- Shop Vacuum

### Tools that may be Required (Site Specific):

- Shovel
- Hammer Drill
- 3/8" Masonry Drill Bit



## CONTENTS

Common Hardware Parts .....	1
Brackets, Keys and Splices .....	2
Handrail Components .....	3
Platform Leg Sizing .....	4
Threshold Platform Assembly .....	5
Ramp Guardrail Splice Assembly .....	7
Ramp Walking Surface Assembly .....	8
Ramp Guardrail Assembly .....	10
Platform Guardrail Assembly .....	11
Ramp Handrail Assembly .....	12
Installing Brackets and Keys .....	15
Lag Bolting and Anchoring .....	17
Step Assembly - 30" or Under .....	18
Step Assembly - Over 30" .....	19
Additional Platforms Assembly .....	20
Resting Platform Assembly .....	22
Switchback Platform Assembly .....	23
Installation Checklist .....	25

*Revised: June 2013*

COMMON HARDWARE PARTS

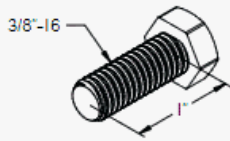

3/8"-16 X 1" HEX HEAD BOLT



3/8" SPLIT LOCK WASHER

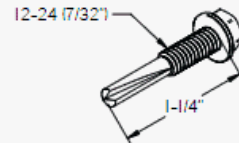

12-24 X 1-1/4" HEX HEAD TEK SCREW

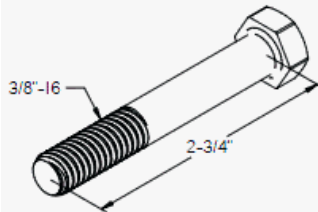

3/8"-16 X 2-3/4" HEX HEAD BOLT

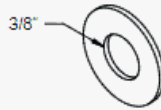

3/8" FLAT WASHER

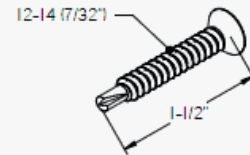

12-14 X 1-1/2" FLAT HEAD PHILLIPS TEK SCREW

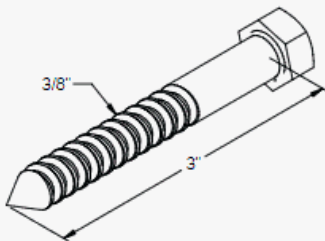

3/8" X 3" HEX HEAD LAG BOLT



3/8"-16 HEX SERRATED FLANGE LOCK NUT

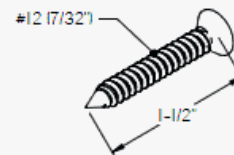

#12 X 1-1/2" FLAT HEAD PHILLIPS WOOD SCREW

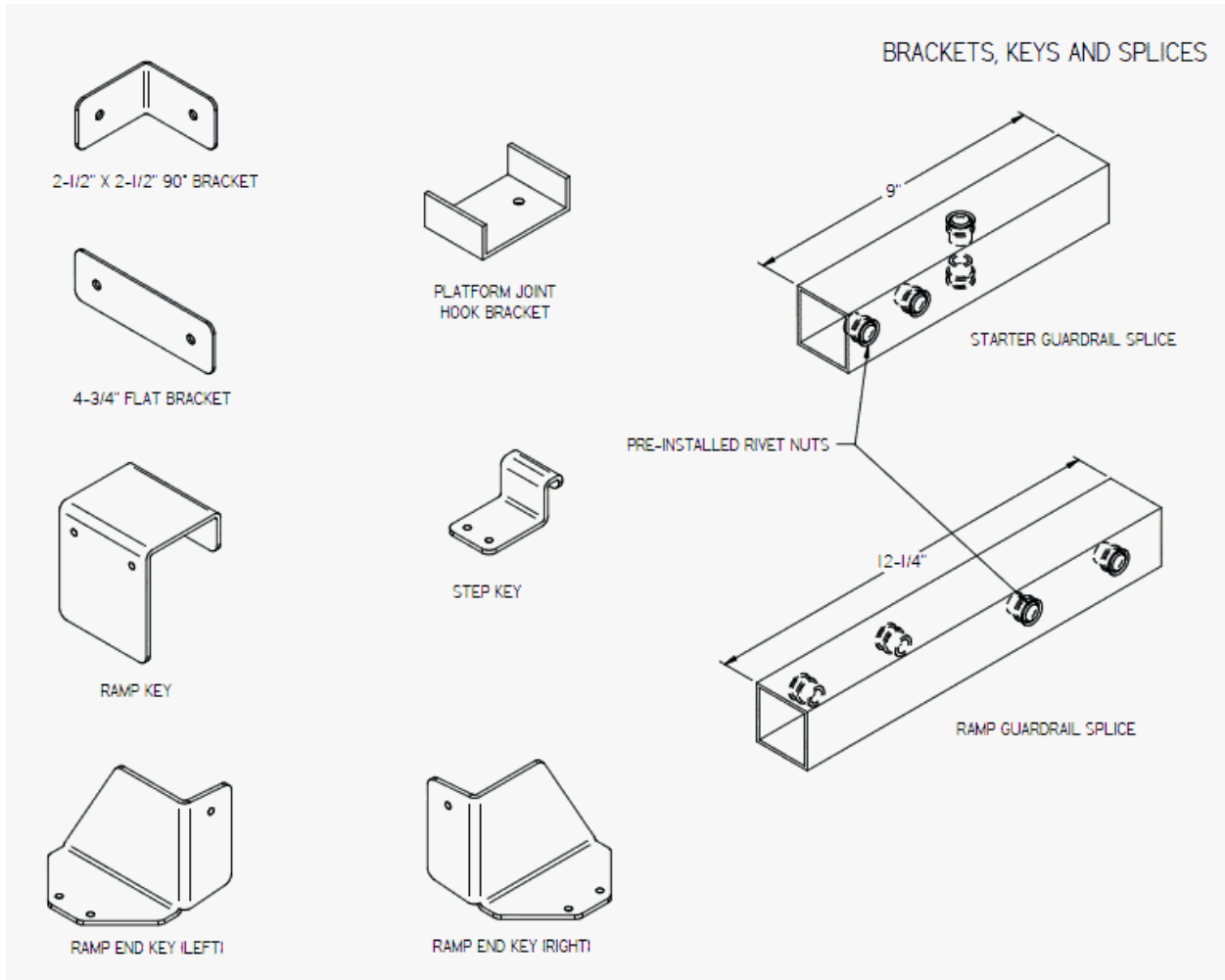

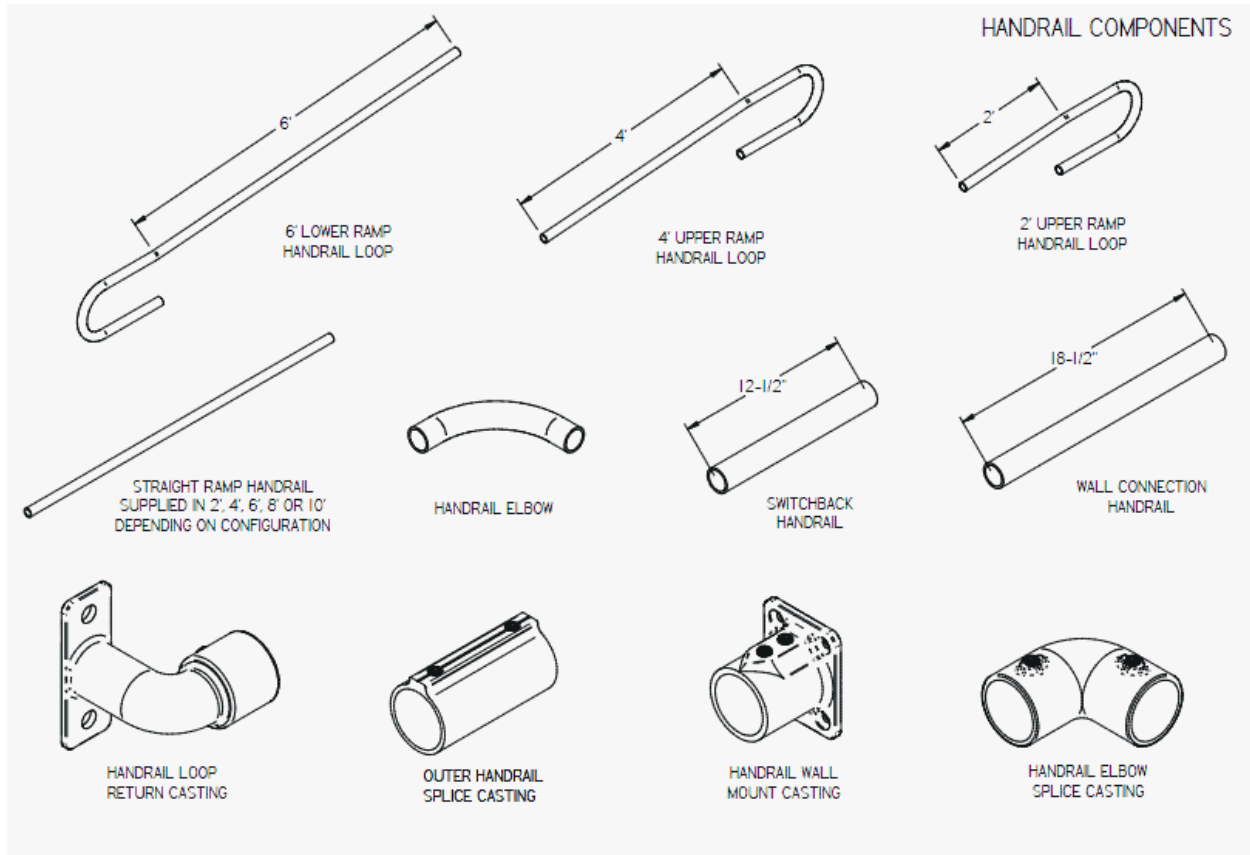

### PLATFORM LEG SIZING

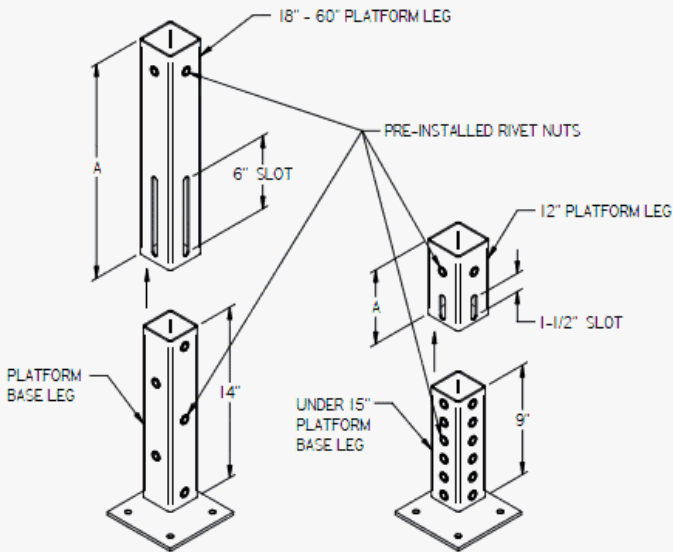

**DETERMINE THE CORRECT PLATFORM LEG SIZE**

- Locate where the legs will rest on the ground.
- Measure up to the threshold height of the door as shown in the picture.
- Use the chart to the left to select the correct leg size for each corner of the platform that requires a leg.
- All legs except for the 12" leg have  $\pm 4.5"$  of adjustability from the nominal size.



PLATFORM LEG SIZING CHART		
PLATFORM HEIGHT	LEG SIZE	ACTUAL LEG LENGTH (DIM. "A")
* 8" - 15.5"	12"	6-1/16"
* 13.5" - 22.5"	18"	11-9/16"
19.5" - 28.5"	24"	17-9/16"
25.5" - 34.5"	30"	23-9/16"
31.5" - 40.5"	36"	29-9/16"
37.5" - 46.5"	42"	35-9/16"
43.5" - 52.5"	48"	41-9/16"
49.5" - 58.5"	54"	47-9/16"
55.5" - 64.5"	60"	53-9/16"

\* NOTE: In order to achieve some of the lower heights in this range, the base leg may have to be cut off in order to fit properly.

NOTE: THE FIRST PLATFORM SET UNDER THE DOOR WILL REQUIRE 4 LEGS. ADDITIONAL PLATFORMS WILL REQUIRE EITHER 2 LEGS OR 1 LEG DEPENDING ON ITS LOCATION. SEE PAGE 20 FOR MORE DETAILS.

To begin installing a ramp or step, start by determining the height of legs required for the first platform set under the door threshold as described on page 4. Always start by setting the first platform at the door and working your way towards the ground, either with a ramp or a step.

NOTE: TIGHTEN ALL BOLTS TO A TORQUE OF 25 FT-LB.

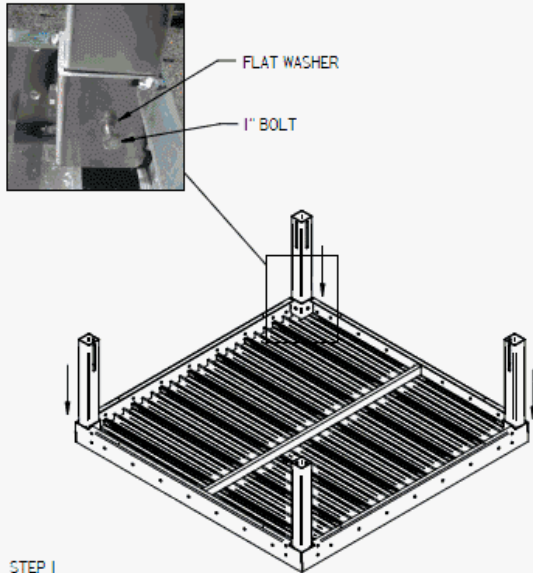

**STEP 1**

- Lay the platform upside down on the ground.
- Insert 4 platform legs into the corner pockets and make sure the holes align as shown in the picture.
- Use (2) 1" bolts with (2) flat washers to secure each leg to each pocket found in hardware kit HK00051.
- The bolts will thread into the pre-installed rivet nuts in the ends of the platform legs.

**THRESHOLD PLATFORM ASSEMBLY**

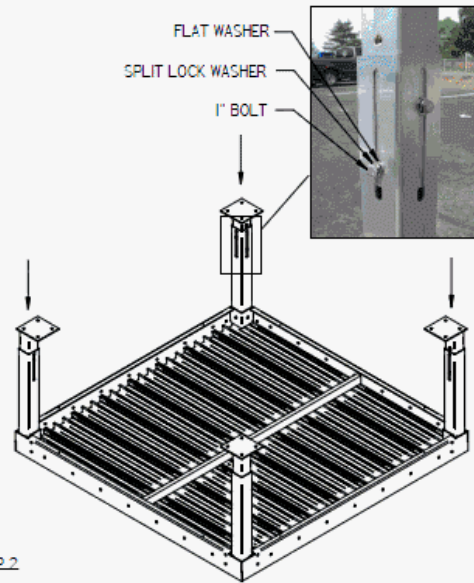

**STEP 2**

- Insert 4 platform base legs into the platform legs and make sure the holes align with the slots as shown in the picture.
- Use (2) 1" bolts with (2) lock washers and (2) flat washers to secure each base leg to each platform leg (found in hardware kit HK00051) at the desired height.
- The bolts will thread into the pre-installed rivet nuts in the base legs.
- This connection may need to be adjusted later in order to level the platform.

CONTINUE TO NEXT PAGE

### THRESHOLD PLATFORM ASSEMBLY

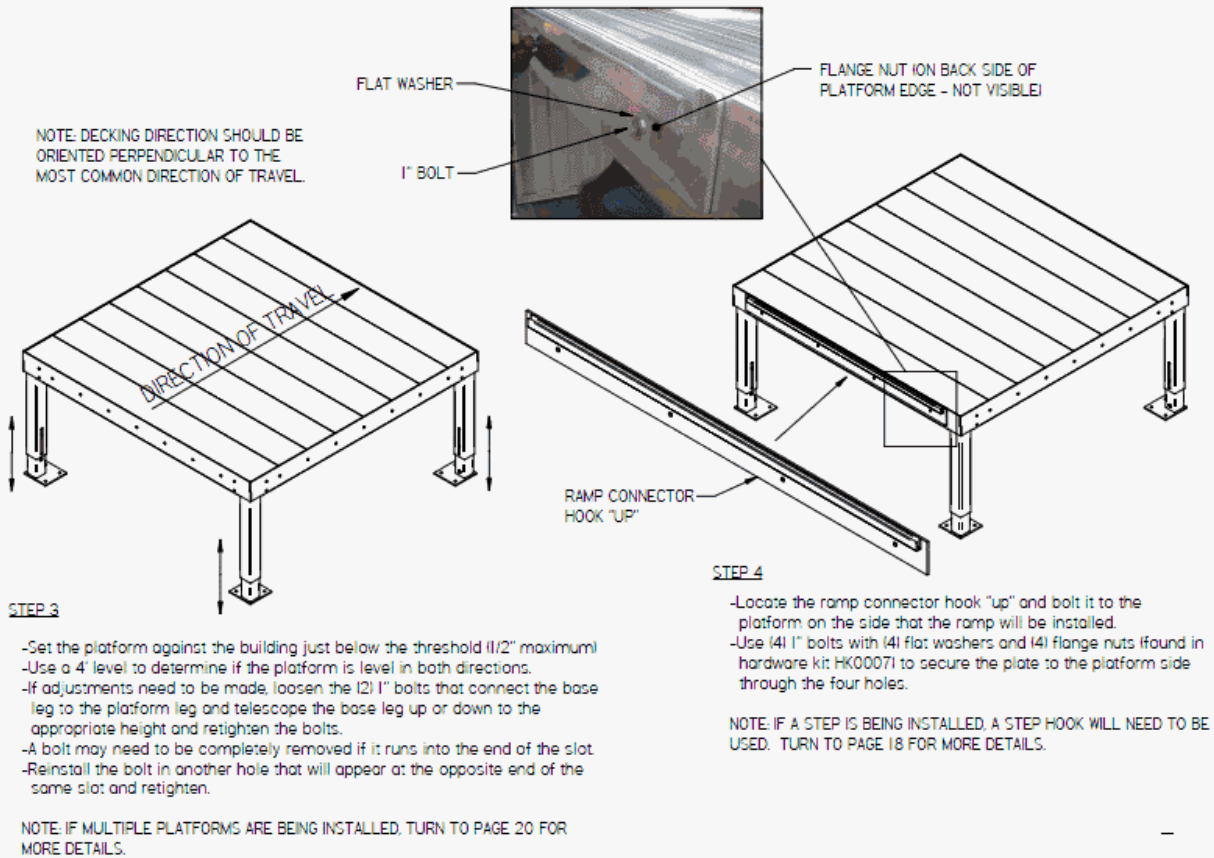

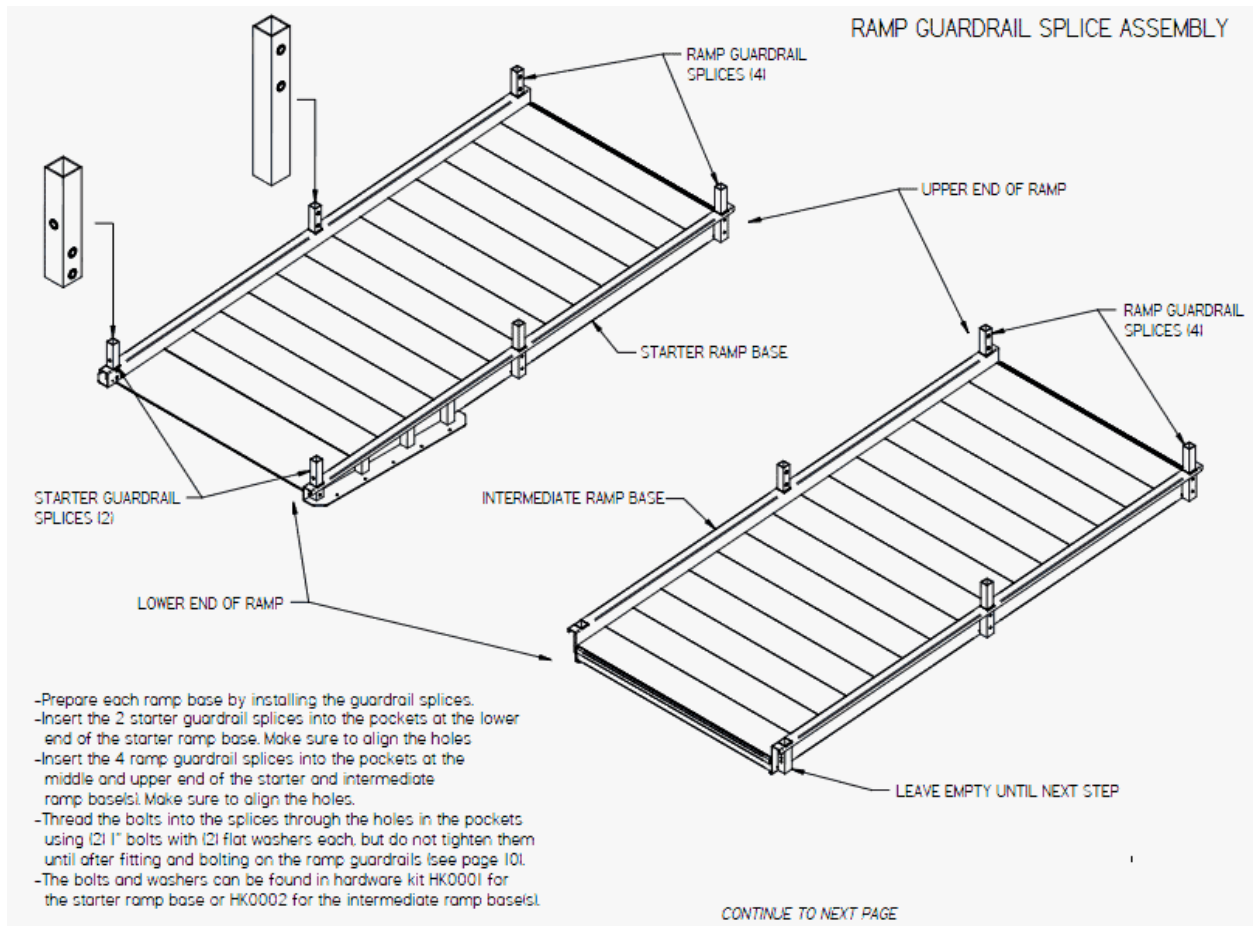



**RAMP WALKING SURFACE ASSEMBLY**

**STEP 1**

- Start by inserting two ramp legs into the pockets on the ramp base that have 3 holes as shown in DETAIL A.
- Temporarily insert a 2-3/4\" bolt (found in hardware kit HK0002) through one of the three holes to set the leg at a height that allows the bottom of the ramp section to be about 8\" - 10\" lower than the platform.
- Lift the upper end of the ramp section and hook it on to the "up" hook that was previously bolted to the platform.

**STEP 2**

- Check to make sure the ramp is declining at a 1:12 slope. The ramp should drop 1\" for every 12\" for 1 foot of horizontal distance.
- Rest one end of the level on the ramp surface and then hold it so it is level. Over the length of the 4' level, the ramp surface should drop 4\".
- Adjust the legs up or down until it drops 4\" as shown in the picture to the left.
- To adjust the height, remove the 2-3/4\" bolt from the 3 hole pocket and reinsert it along with a flat washer at the proper height. Use a flange nut on the other side to tighten the bolt in place.
- Also check to make sure the ramp surface is level across the width of the decking. Make adjustments as necessary.

*CONTINUE TO NEXT PAGE*

**STEP 3**

- Repeat the procedure for the next ramp base as described on page 8.
- Hook it on to the "up" hook at the lower end of the previous ramp base.

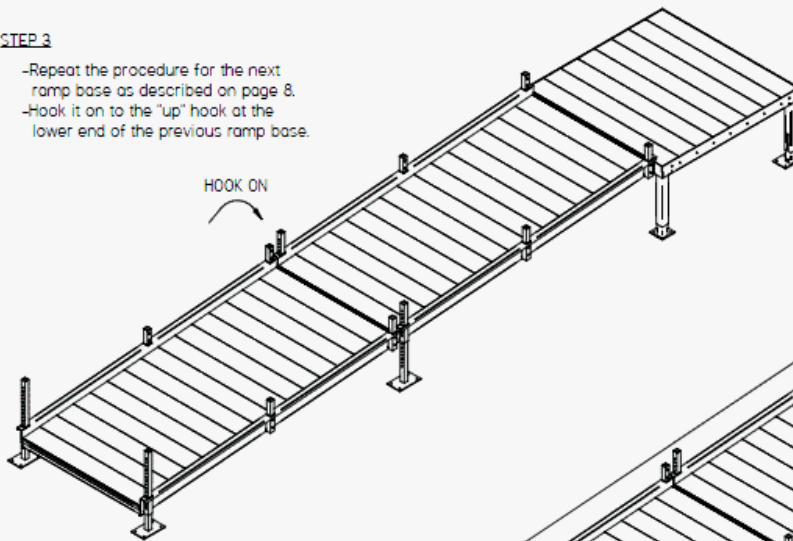

**RAMP WALKING SURFACE ASSEMBLY**

**STEP 5**

- Look down the length of the ramp and check to see if all the ramp edges are aligned. You may want to use a string line to check this.
- If they are not aligned, you must adjust the ramp legs slightly until all sections are in a straight line.
- Check this on both sides of the ramp if possible.

**STEP 4**

- Hook on the starter section.
- The starter footplates should be resting on the ground.
- Make sure the bottom of the starter is sitting on level ground.

CHECK TO MAKE SURE STARTER IS LEVEL

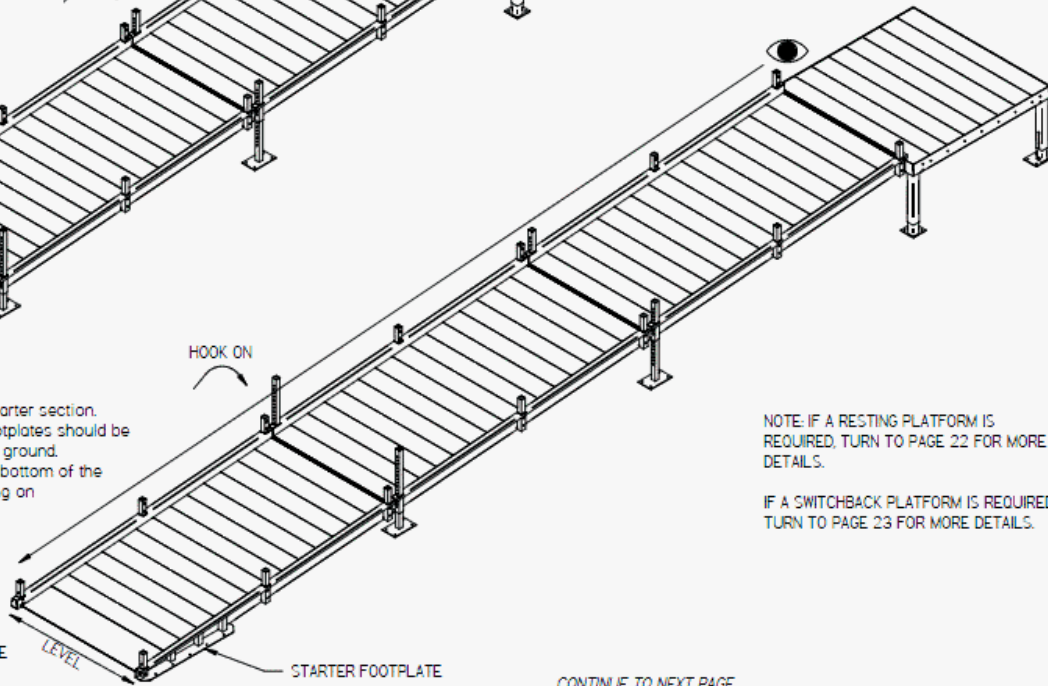

NOTE: IF A RESTING PLATFORM IS REQUIRED, TURN TO PAGE 22 FOR MORE DETAILS.

IF A SWITCHBACK PLATFORM IS REQUIRED, TURN TO PAGE 23 FOR MORE DETAILS.

CONTINUE TO NEXT PAGE

**STEP 1**

- Slide the 3 posts of a guardrail over top of the 3 splices on both sides of the starter section (only one side shown). Make sure to slide the rail down evenly to prevent it from binding on the splices.
- Bolt each post to the splices through the 2 holes using (2) 1" bolts with (2) flat washers (found in hardware kit HK0001). All bolts will be inserted through the posts from the inside of the guardrail.

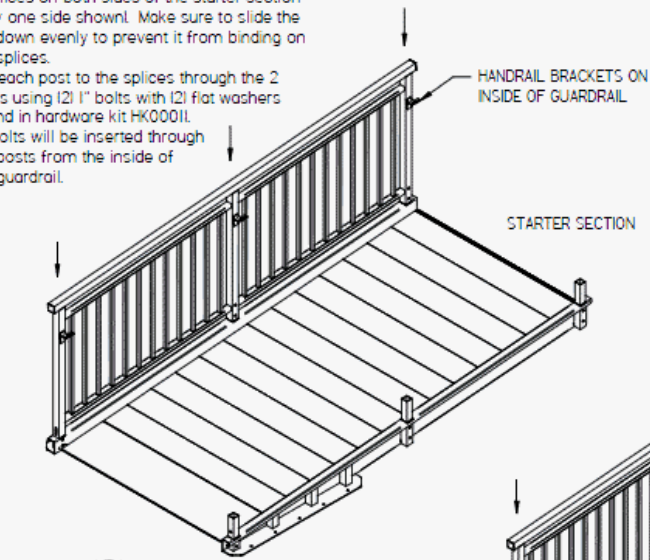

**RAMP GUARDRAIL ASSEMBLY**

**STEP 2**

- Slide the 3 posts of a guardrail over top of the 2 splices and 1 ramp leg on both sides of each of the intermediate sections (only one side shown). Make sure to slide the rail down evenly to prevent it from binding on the splices.
- Bolt the two upper posts to the splices through the two holes using (2) 1" bolts with (2) flat washers (found in hardware kit HK0002). All bolts will be inserted from the inside of the guardrail.
- Bolt the lower post through the slot and the leg as shown in DETAIL B with a single 2-3/4" bolt, flat washer and flange nut (found in hardware kit HK0002).
- Continue with all other ramp sections until all ramp guardrails are bolted.

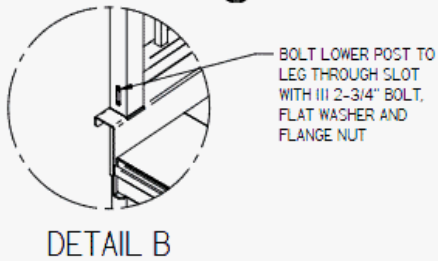
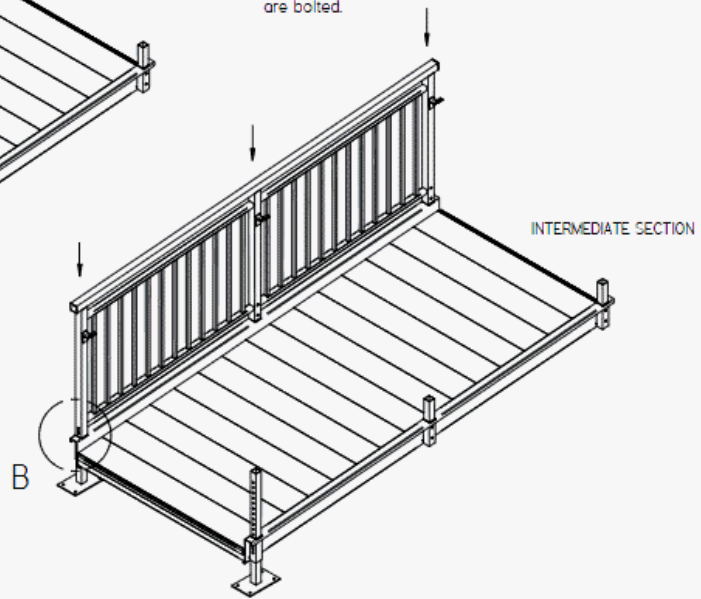

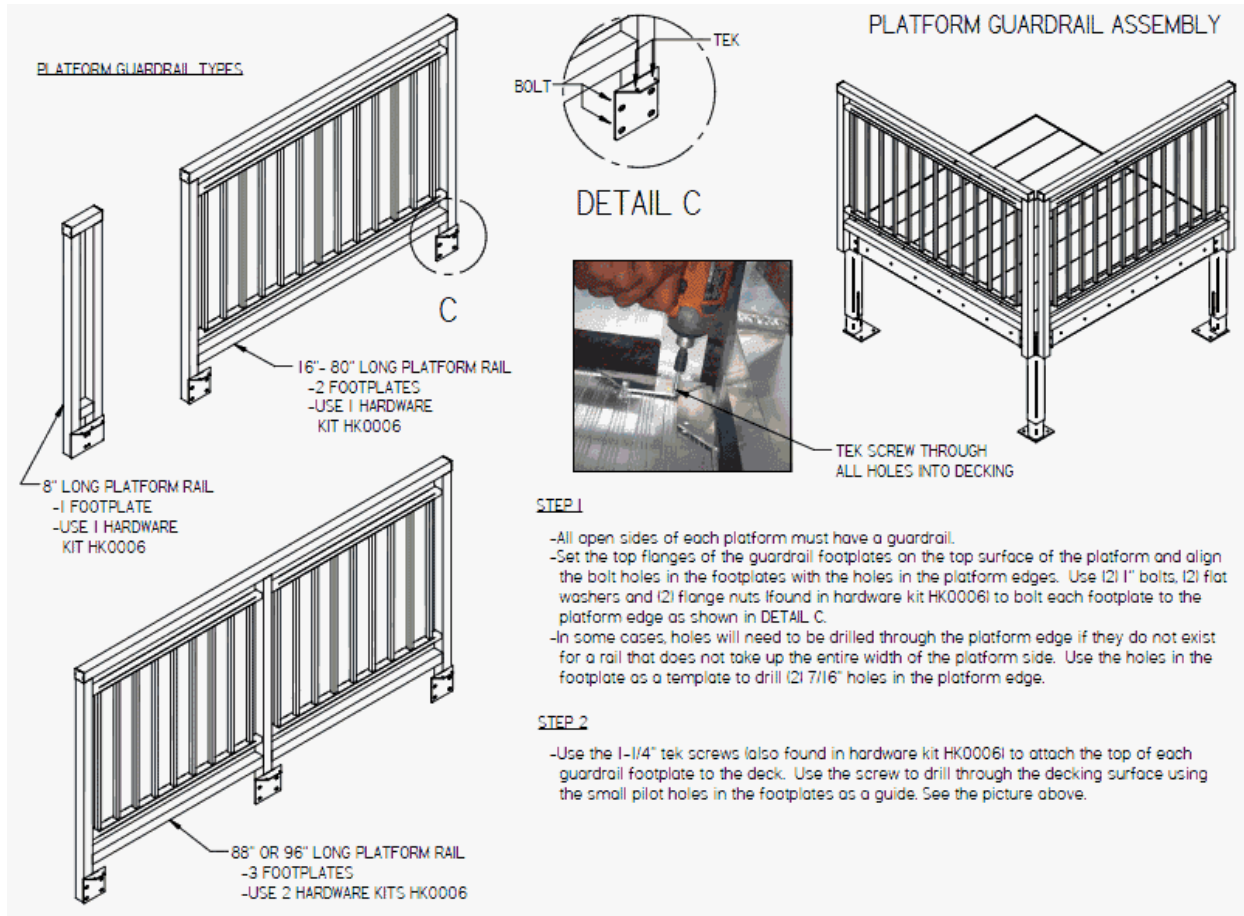

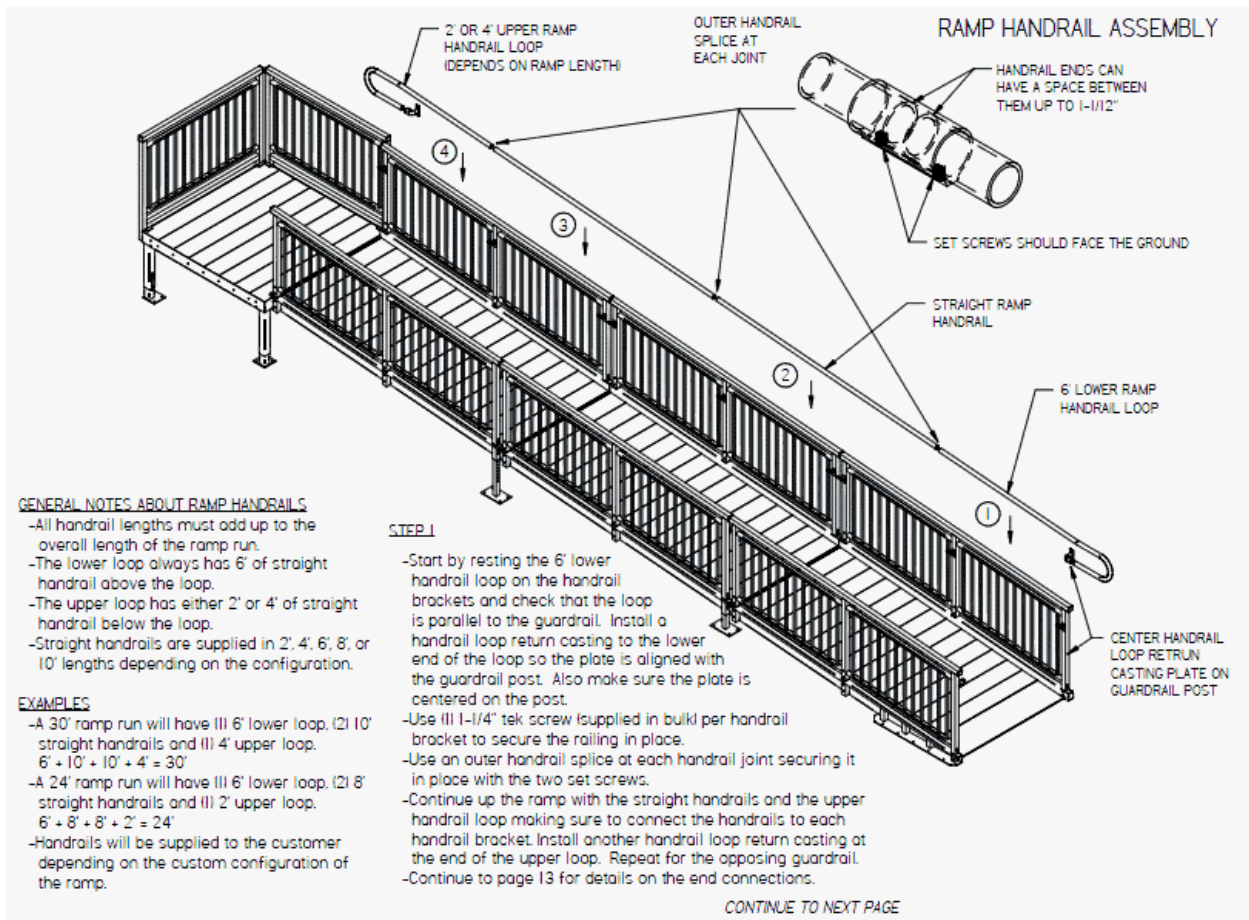

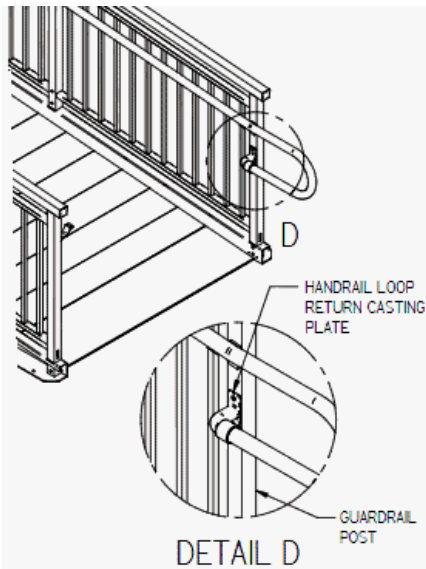

**STEP 2**

**HANDRAIL LOOPS (LOWER AND UPPER)**

- Clamp the handrail loop return casting plate to the guardrail post with a c-clamp.
- Using the hole as a guide, drill a 7/16" hole through both walls of the post. Secure the plate to the post with a 2-3/4" bolt, washer and flange nut (found in hardware kit HK0008).
- Remove the c-clamp and repeat the drilling and bolting for the other hole.

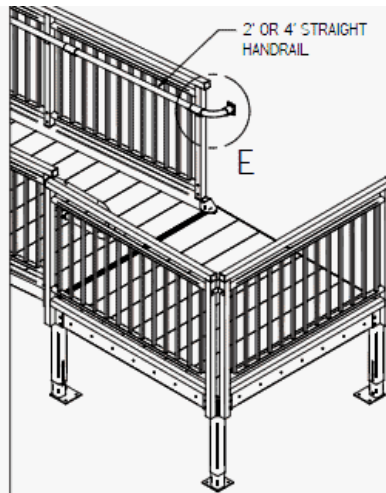

**STEP 3 (IF REQUIRED)**

**HANDRAIL ELBOWS (RETURN TO WALL)**

- Use an outer handrail splice to connect the elbow to the end of a straight handrail as shown in DETAIL E.
- Insert the other end of the elbow into the wall mount casting.
- Secure the wall mount casting to the wall of the building using (4) 1-1/2" screws (found in hardware kit HK0010). Use the appropriate screws for screwing into either wood or sheet metal depending on the construction of the building wall.
- Tighten the two set screws in the wall mount casting.
- An additional straight handrail and outer handrail splice may be required if the ramp guardrail is further away from the building.

**RAMP HANDRAIL ASSEMBLY**

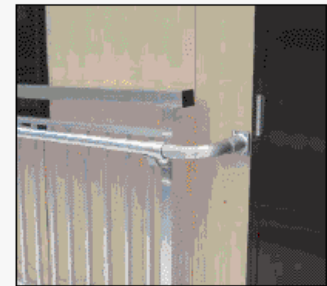
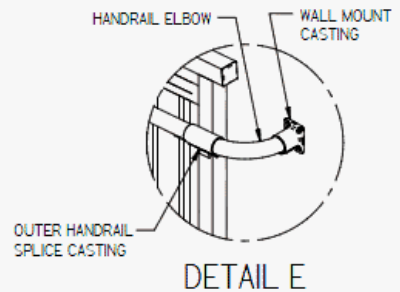

CONTINUE TO NEXT PAGE

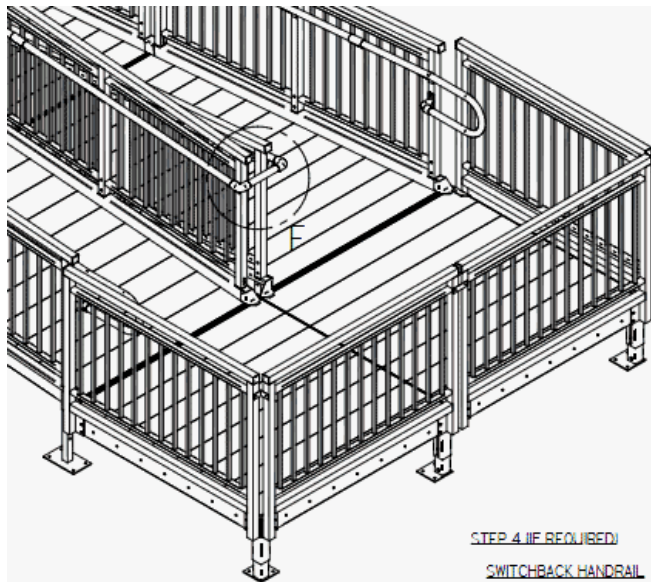

RAMP HANDRAIL ASSEMBLY



STEP 4 (IF REQUIRED)

SWITCHBACK HANDRAIL

- Slide two handrail elbow castings over the ends of a switchback handrail.
- Then slide the two elbow castings over the ends of the two handrails that need to be connected on the inside of a switchback or 180° turn in the ramp configuration as shown in DETAIL F.
- Tighten the two set screws on both of the elbow castings to secure the switchback handrail to the handrails previously attached to the ramp guardrail. The set screws should face the ground.

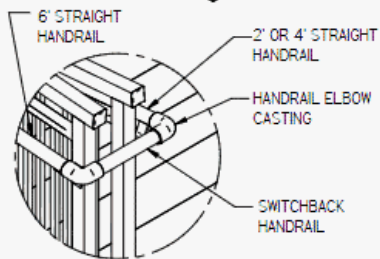

DETAIL F

NOTE: SINCE THERE ARE NO LOOPS AT THIS CONNECTION, THERE WILL BE A 6' STRAIGHT HANDRAIL LEADING UP THE RAMP AND EITHER A 2' OR 4' STRAIGHT HANDRAIL GOING DOWN THE RAMP FROM THE SWITCHBACK HANDRAIL.

CONTINUE TO NEXT PAGE

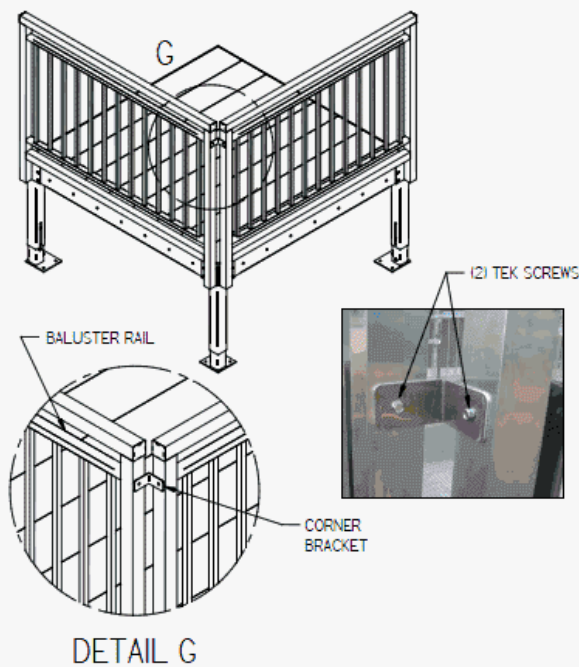

**CORNER BRACKETS**

- Any two platform rails that meet at a corner should be connected by a corner bracket. Corner brackets should also be used to connect guardrails to the wall of the building.
- Use a c-clamp to hold the corner bracket in place to one of the guardrail posts. The top of the bracket should be flush with the top of the baluster rail as shown in DETAIL G.
- Use a 1-1/4" tek screw (supplied in bulk) to secure the bracket to the adjacent rail. The hole in the bracket should be used as a drilling guide.
- Remove the c-clamp and use another 1-1/4" tek screw to secure the other side of the bracket where the clamp was initially.

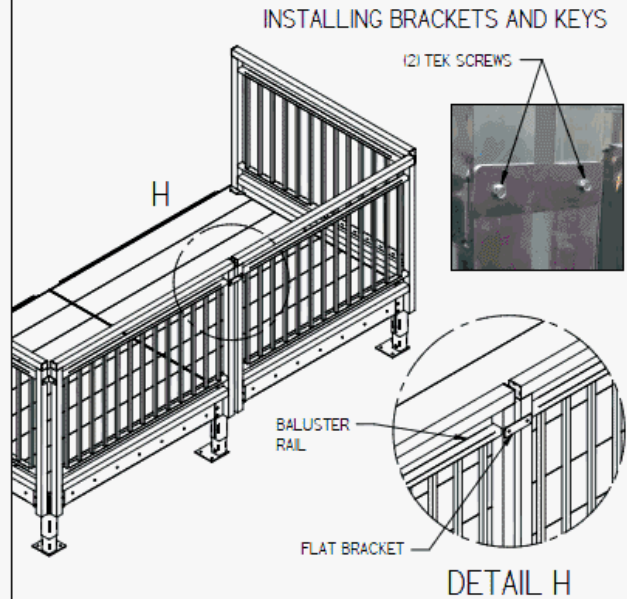

**FLAT BRACKETS**

- Any two platform rails that are aligned along platform edges should be connected by a flat bracket.
- Use a c-clamp to hold the flat bracket in place to one of the guardrail posts. The top of the bracket should be flush with the top of the baluster rail as shown in DETAIL H.
- Use a 1-1/4" tek screw (supplied in bulk) to secure the bracket to the adjacent rail. The hole in the bracket should be used as a drilling guide.
- Remove the c-clamp and use another 1-1/4" tek screw to secure the other side of the bracket where the clamp was initially.

CONTINUE TO NEXT PAGE



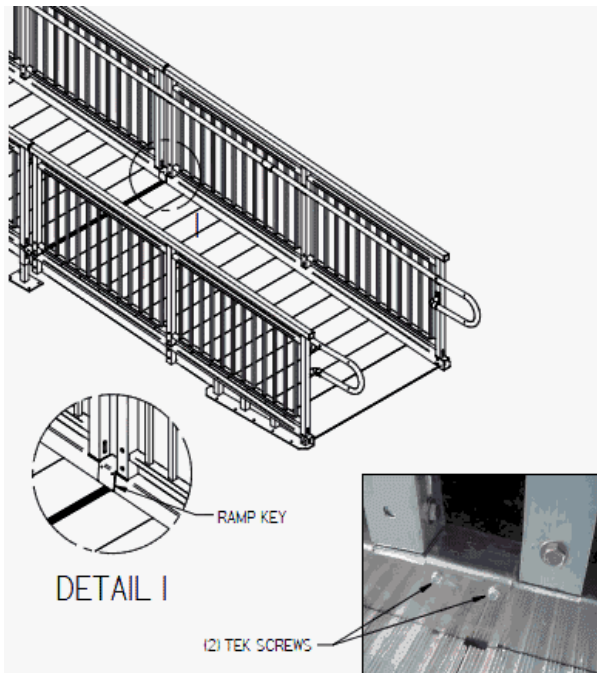

**RAMP KEYS**

- At each ramp section joint two ramp keys are required to secure the two sections together.
- Hook the key over the ramp edge with the long flange against the ramp deck as shown in DETAIL I. The key will fit between the two ramp guardrail posts that are about 3-1/2" apart.
- Use 12) 1-1/4" tek screws (supplied in bulk) to secure the ramp key to the ramp edge. The holes in the key should be used as a drilling guide.

**INSTALLING BRACKETS AND KEYS**

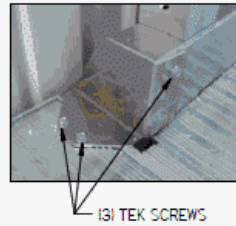

**RAMP END KEYS**

- Wherever a ramp meets a platform, two ramp end keys (left and right) are required to secure the two together.
- Orient the end key as shown in DETAIL J over the end of the ramp edge.
- Use 13) 1-1/4" tek screws (supplied in bulk) to secure the ramp key to the ramp edge and platform decking as shown in the picture above. The holes in the key should be used as a drilling guide.

CONTINUE TO NEXT PAGE

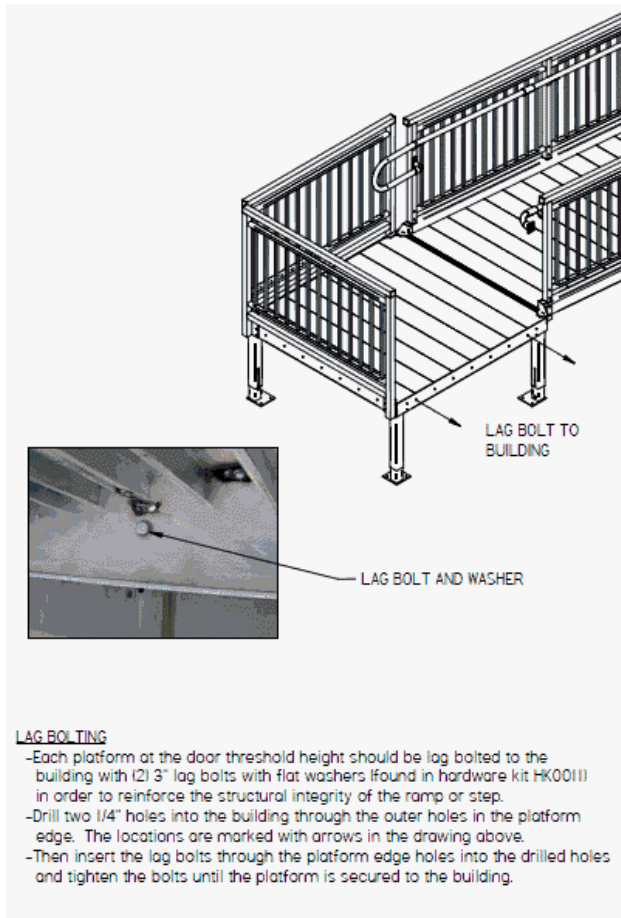

**LAG BOLTING**

- Each platform at the door threshold height should be lag bolted to the building with (2) 3" lag bolts with flat washers (found in hardware kit HK0011) in order to reinforce the structural integrity of the ramp or step.
- Drill two 1/4" holes into the building through the outer holes in the platform edge. The locations are marked with arrows in the drawing above.
- Then insert the lag bolts through the platform edge holes into the drilled holes and tighten the bolts until the platform is secured to the building.

**LAG BOLTING AND ANCHORING**



**CONCRETE ANCHORING (IF REQUIRED)**

- Some job sites require that the footplates be anchored to a concrete surface or footing.
- Secure each footplate to the concrete using a 3/8" concrete anchor. The anchor shown in the picture is a concrete wedge anchor that is 3-3/4" long. Any 3/8" anchor is acceptable.
- Install the anchors according to the concrete anchor manufacturer's instructions.
- Only 1 anchor is required per footplate. Extra holes exist in each footplate for installation convenience.

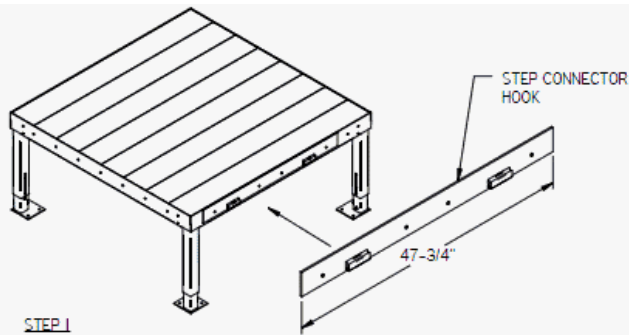

**STEP 1**

- Refer to pages 4-6 for instructions on how to assemble the platform.
- Locate the step connector hook and bolt it to the platform on the side that the step will be installed. As shown, the step is off center of the platform, away from the building. Consult the job-specific layout to determine where the step should be connected to the platform.
- Use (4) 1" bolts with (4) flat washers and (4) flange nuts (found in hardware kit HK0007) to connect the plate to the platform side through the four holes. If holes in the platform edge are missing, they will need to be drilled through with a 7/16" drill bit.

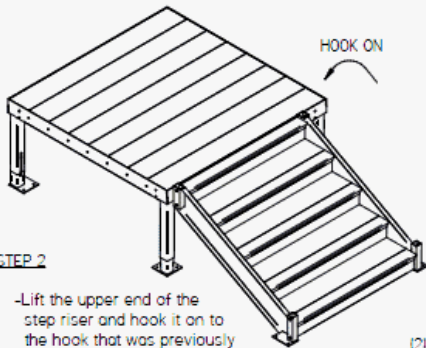

**STEP 2**

- Lift the upper end of the step riser and hook it on to the hook that was previously bolted on the platform.

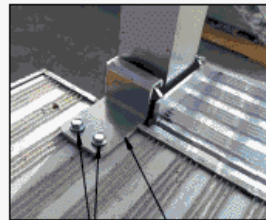

(2) TEK SCREWS — STEP KEY

CONTINUE TO PAGE 11 FOR PLATFORM GUARDRAIL ASSEMBLY

**STEP ASSEMBLY - 30" OR UNDER**

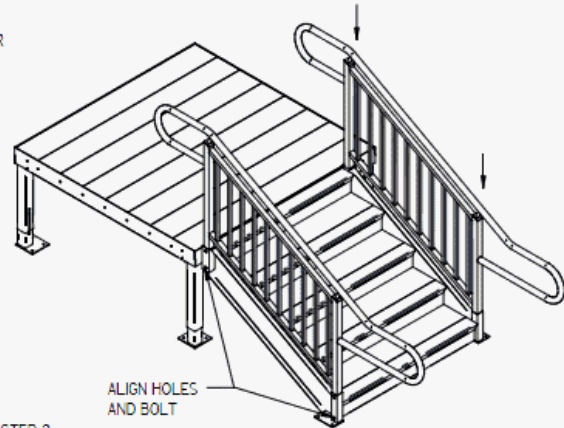

**STEP 3**

- Insert the step guardrail posts into the upper and lower pockets on the step riser until the pre-installed rivet nuts in the posts align with the slots in the pockets.
- Use (8) 1" bolts with flat washers (found in hardware kit HK0003) to secure the four posts to the four pockets. Thread the bolts into the rivet nuts in the step rail posts through the slots in the upper and lower pockets on the step riser.

**STEP 4**

- At the top of each step, two step keys are required to secure the step to the platform.
- Orient the key as shown against the back side of the upper pockets on the step riser.
- Use (2) 1-1/4" tek screws (supplied in bulk) to secure the step key to the platform decking. The holes in the key should be used as a drilling guide.

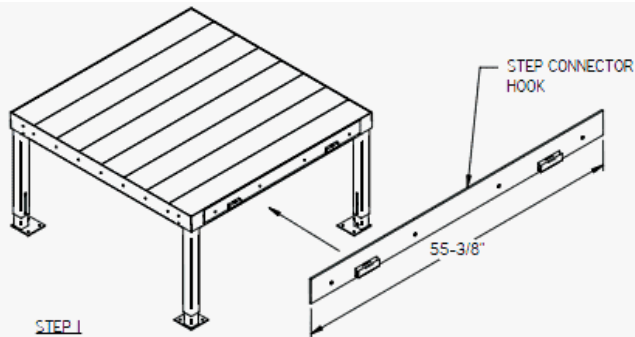

**STEP 1**

- Refer to pages 4-6 for instructions on how to assemble the platform.
- Locate the step connector hook and bolt it to the platform on the side that the step will be installed. As shown, the step is on center of the platform. Consult the job-specific layout to determine where the step should be connected to the platform.
- Use (4) 1" bolts with (4) flat washers and (4) flange nuts (found in hardware kit HK0007) to connect the plate to the platform side through the four holes. If holes in the platform edge are missing, they will need to be drilled through with a 7/16" drill bit.

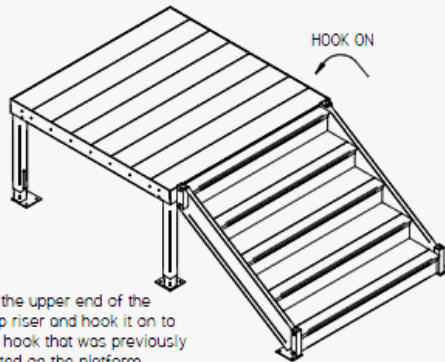

**STEP 2**

- Lift the upper end of the step riser and hook it on to the hook that was previously bolted on the platform.

NOTE: STEPS OVER 30" ARE WIDER AND REQUIRE A LONGER STEP HOOK

**STEP ASSEMBLY - OVER 30"**

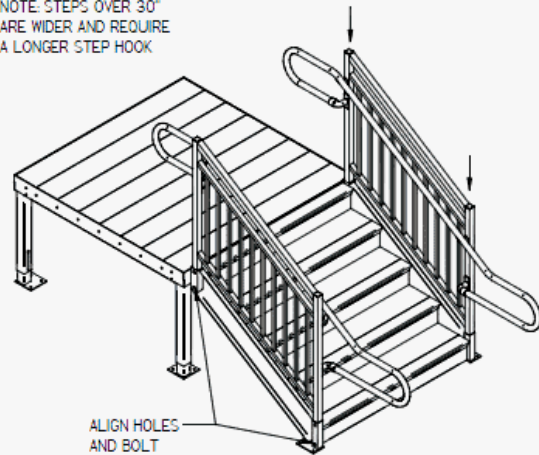

**STEP 3**

- Insert the step guardrail posts into the upper and lower pockets on the step riser until the pre-installed rivet nuts in the posts align with the slots in the pockets.
- Use (8) 1" bolts with flat washers (found in hardware kit HK0003) to secure the four posts to the four pockets. Thread the bolts into the rivet nuts in the step rail posts through the slots in the upper and lower pockets on the step riser.
- Steps over 50" high will have three posts per guardrail instead of two as shown. Hardware kit HK0004 will need to be used for steps over 50" since it will require 4 extra bolts and washers.

**STEP 4**

- See step 4 on page 18 for instructions on installing step keys.

CONTINUE TO PAGE 11 FOR PLATFORM GUARDRAIL ASSEMBLY

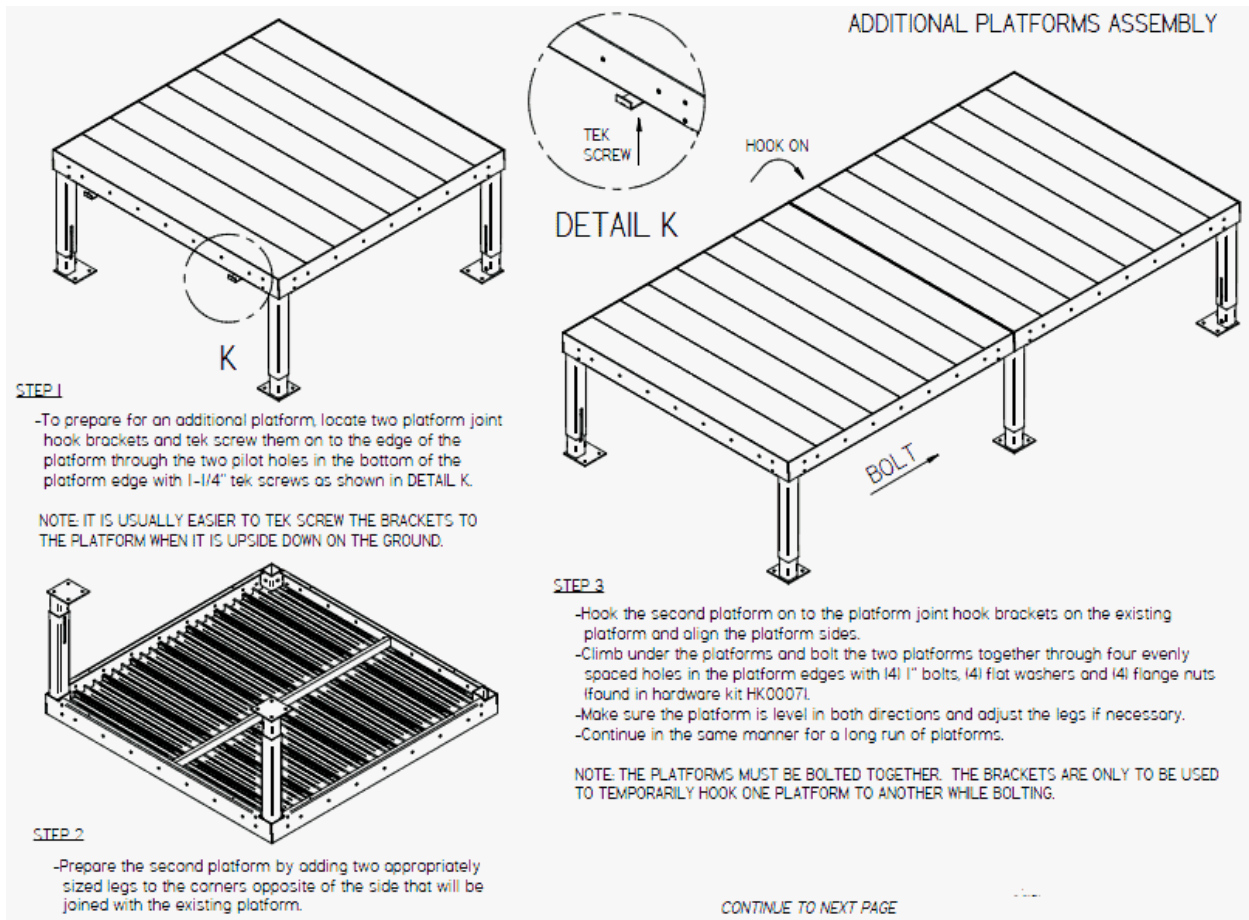

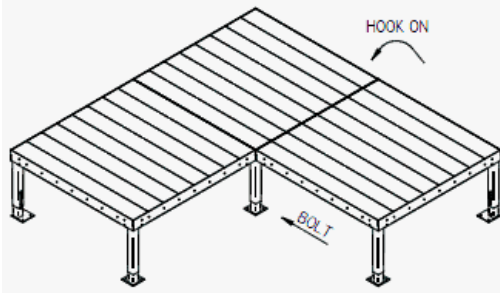

**STEP 4 (IF REQUIRED)**

- If additional platforms are required extending outward from the building, tek screw two more platform joint hook brackets to the existing platform and prepare another platform with two legs (shown in step 2 on the previous page).
- Hook the additional platform on and bolt through the edges (shown in step 3).

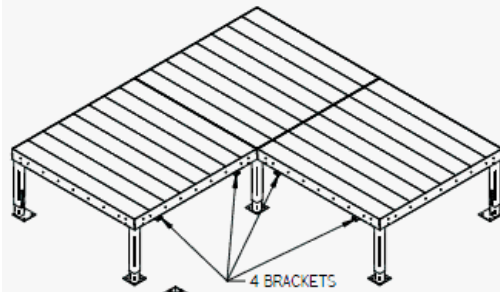

**STEP 5 (IF REQUIRED)**

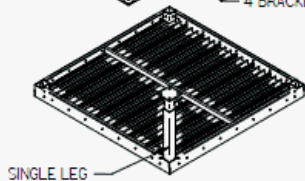

- To prepare for a platform bolting to 2 other platforms, tek screw 4 platform joint hook brackets in the locations shown above.
- This platform will require only one leg as shown since the other three corners will be supported by existing legs.

**ADDITIONAL PLATFORMS ASSEMBLY**

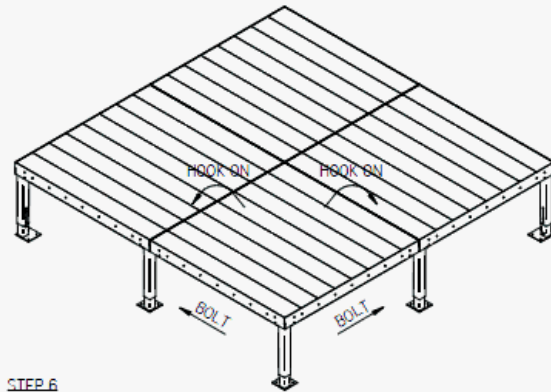

**STEP 6**

- Bolt the single leg platform to the two existing platforms through the holes in BOTH of the mating platform edges with (4) 1" bolts, (4) flat washers and (4) flange nuts each use 2 hardware kits HK00071.
- To make this platform larger, continue in the same manner using the diagram below to determine how many legs to use on each platform extending outward from the building.

NUMBER OF LEGS PER PLATFORM		BUILDING WALL
CONTINUE ALONG BUILDING ←	2	2
	1	1
	1	1
	4	2
		2
		2

↑ CONTINUE AWAY FROM BUILDING

← FIRST PLATFORM

CONTINUE TO NEXT PAGE

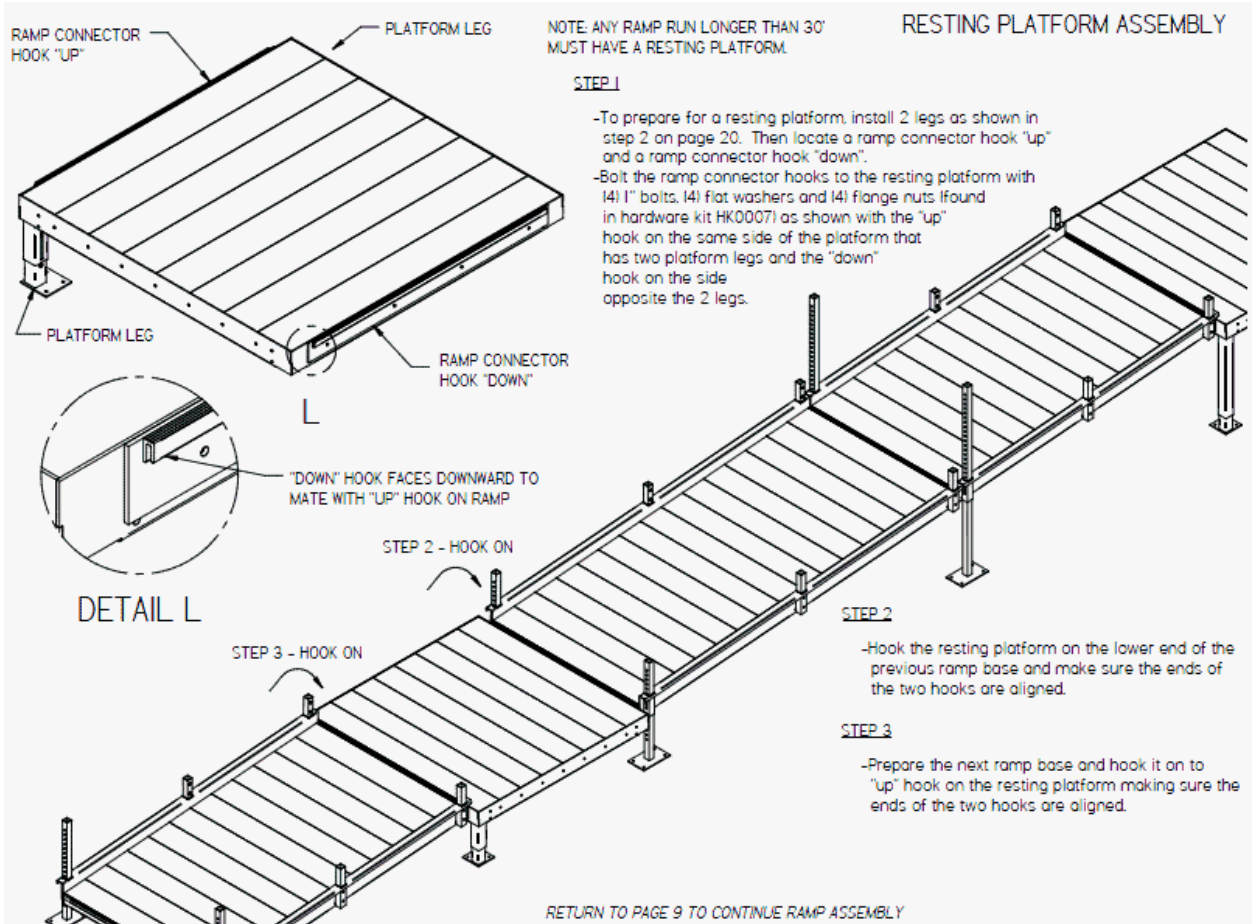

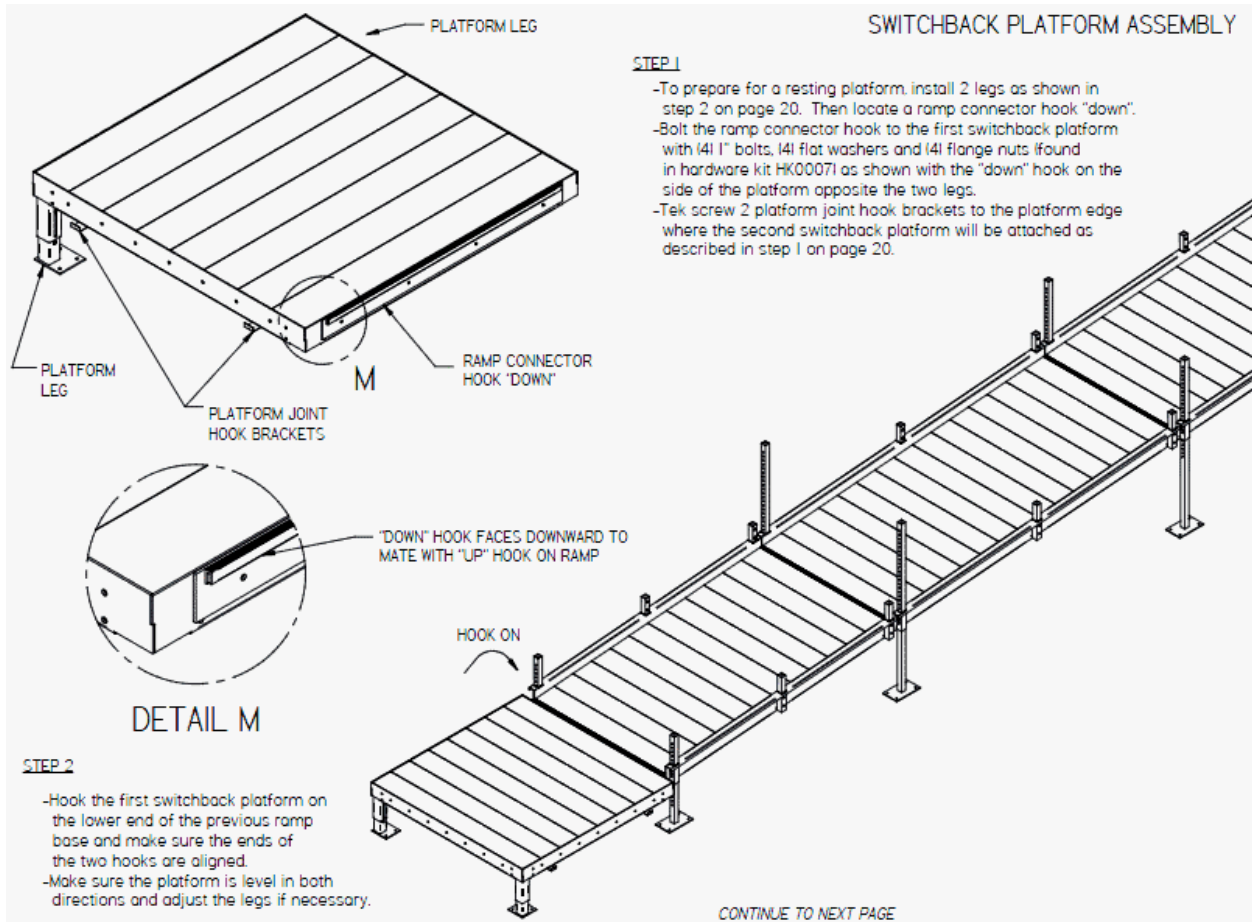



## SWITCHBACK PLATFORM ASSEMBLY

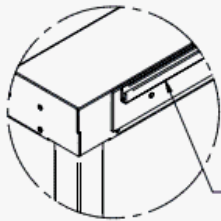
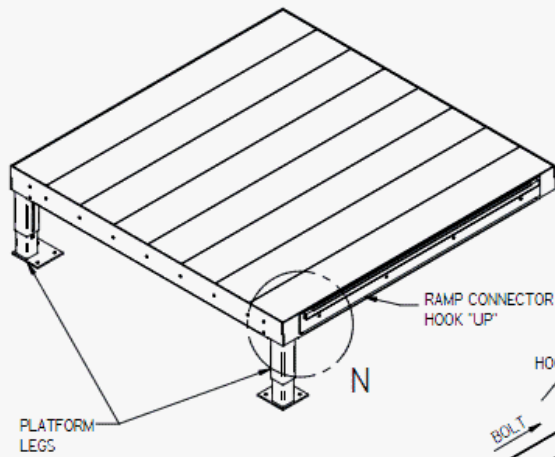

DETAIL N

"UP" HOOK FACES UPWARD TO MATE WITH "DOWN" HOOK ON RAMP

### STEP 3

- To prepare the second resting platform, install 2 legs as shown in step 2 on page 20. Then locate a ramp connector hook "up".
- Bolt the ramp connector hook to the second switchback platform with (4) 1" bolts, (4) flat washers and (4) flange nuts (found in hardware kit HK0007) as shown with the "up" hook on the side of the platform next to the 2 legs.
- Climb under the platforms and bolt the 2 platforms together through 4 evenly spaced holes in the platform edges with (4) 1" bolts, (4) flat washers and (4) flange nuts (found in hardware kit HK0007). Depending on how low to the ground these platforms are, it may be easier to bolt them together upside down and flip them over before hooking them on to the upper ramp section.
- Make sure the platform is level in both directions and adjust the legs if necessary.

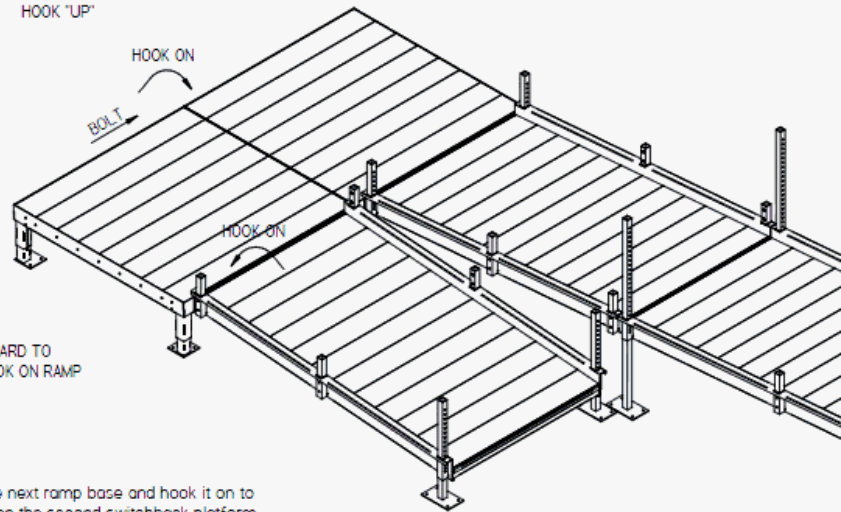

### STEP 4

- Prepare the next ramp base and hook it on to "up" hook on the second switchback platform making sure the ends of the two hooks are aligned.

RETURN TO PAGE 9 TO CONTINUE RAMP ASSEMBLY

INSTALLATION CHECKLIST



CHECK OFF THE ITEMS BELOW TO MAKE SURE YOUR RAMP OR STEP IS PROPERLY INSTALLED

---



ALL BOLTS HAVE BEEN TIGHTENED TO A TORQUE OF 25 FT-LB



ALL RAMP HANDRAILS HAVE BEEN INSTALLED ACCORDING TO PAGES 12 - 14



ALL GUARDRAIL BRACKETS HAVE BEEN INSTALLED ACCORDING TO PAGE 15



ALL RAMP KEYS HAVE BEEN INSTALLED ACCORDING TO PAGE 16



ALL STEP KEYS HAVE BEEN INSTALLED ACCORDING TO PAGE 18



ALL THRESHOLD HEIGHT PLATFORMS HAVE BEEN LAG BOLTED TO THE BUILDING ACCORDING TO PAGE 17



ALL FOOTPLATES HAVE BEEN ANCHORED TO A CONCRETE SURFACE ACCORDING TO PAGE 17 (IF REQUIRED)



ALL MATING PLATFORMS HAVE BEEN BOLTED TOGETHER ACCORDING TO PAGES 20 - 21