

Vision
recumbent bicycles®

**Accessories and
Sales Handbook**



**Toll Free: 877-433-4273
425-673-2448 Fax: 673-4668
www.VisionBikes.com**

Accessories - AB40

The AB40 above seat conversion kit is designed to convert compatible bikes from underseat steering to above seat steering.

This kit will is designed for all R40 series (i.e. R40, R44 and R45) and all R50 series (i.e. R50, R54 and R55) bicycles only.

This kit should only be installed by a bike shop. Several specific mechanical operations are required to install this kit, and improper installation could lead to loss of control of the bike, resulting in a crash and injury to the rider.

You will probably need new grips and new control cables to install this handlebar. We have included the gear and brake casings, as these are hard to find lengths.

The pinch bolt should be set so the bars will rotate forward (to ease mounting the bike) when 30-50 pounds of pressure is applied to the bars.

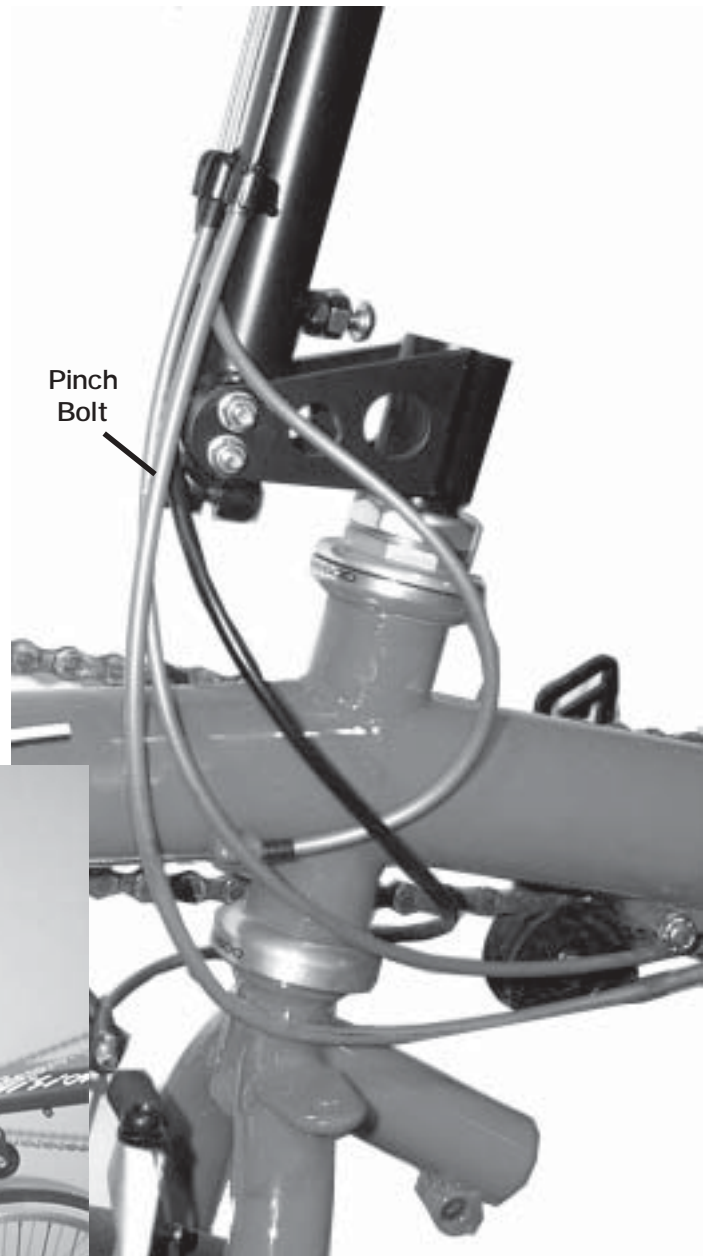

Accessories - CS50 Suspension Centerstand

DO NOT SIT on your bike with the kickstand down!
The Vision suspension bike kickstand is only designed to support the weigh of the bike with a 50 pound load on the rack!

The CS50 is designed for Vision 2000+ R50, R54 and R55 suspension bikes. It will not fit pre-2000 suspension bikes, use the CS41 for the pre-2000 suspesion bikes.

If you sit on the bike with the kickstand down, you will break it, it's your fault, and the IRS will audit you.

To mount your kickstand, follow these instructions:

1. Check your parts. You should have an assembled kickstand unit, one 6 x 16mm nut and bolt set and one 1/4" x 3-1/2" nut and bolt set.

2. Study the illustrations to familiarize yourself with the kickstand. Fig 1. shows the kickstand side view, Fig. 2. shows the kickstand mount close-up. Note how the mounting bracket on the kickstand sits ON TOP of the brace welded to the bike frame.

3. Remove the rear wheel of the bike.

4. Hold the kickstand bracket in place against the swingarm cross-brace. (fig. 2)

This is probably easiest with the bike upside-down. Slide the bracket on the kickstand over the top (think this through if the bike is upside down) surface of the swingarm bracket. the swingarm cross brace.



Accessories - CS50 Suspension Centerstand (cont.)

5. Attach the kickstand. (fig. 3)

Align the cross tube with the holes in the swingarm and slide the 1/4" x 3-1/2" bolt through the swingarm, the kickstand cross tube, and through the other side of the swingarm. Thread the 1/4" nut on the end of the bolt, but do not tighten it yet.

Slide the 6mm bolt through the hole in the end of the kickstand bracket, and through the matching hole in the swingarm cross brace. Thread the 6mm nut on the end of this bolt.

6. Tighten all bolts.

Make sure all the hardware is tight (150 inch pounds).

7. Reinstall the rear wheel.

8. Adjust the stop bumper (fig. 4)

The rubber stop bumper should be adjusted with its threaded post so the legs of the kickstand are parallel to the ground when the kickstand is up.

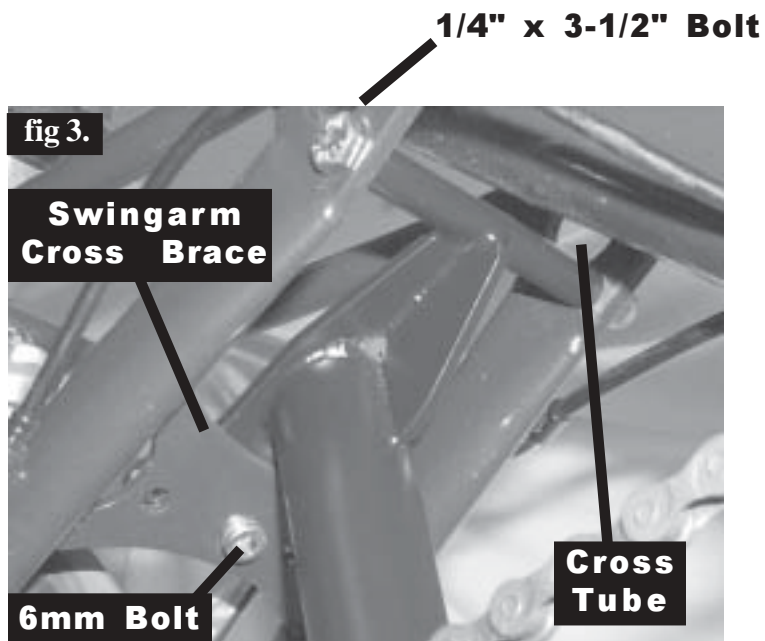

Warranty

This product is warranted for 1 year from date of purchase. ATP will repair or replace this unit, free of charge, upon its return, postage paid, to our location. Call us FIRST for return authorization. This warranty does not cover damage due to alterations or abuse, specifically including, but not limited to, sitting on the bike with the kickstand down. (and we will know if you did!)

Accessories - DB40 DayBag

This 800 cubic inch capacity bag is perfect for commuting, day trips, or as a supplement to your panniers. Now featuring an internal water bladder pocket for a Platypus drinking system (also available from us).

This unit will fit over the SBWB "WaterBack" water bladder holder. You do NOT need the "WaterBack" to mount the DB40.



Vision Day Bag

To attach your VISION™ day bag, first slip the top attachment pocket over the back of your seat. Tighten the strap on the inside of the bag until the pocket holds the seat firmly. Thread the bottom flap straps around the seat crossbar and through the elastic straps on the bottom of the bag. Fasten and tighten the buckles, and you are ready to ride.

Accessories - SBWB WaterBack

This unit is designed to permanently attach to your Vision recumbent bicycle seat back. It provides a tool pouch and a sleeve for standard "backpack" style water bladders. The WaterBack does not come with a water bladder, even though one is shown in these pictures.

To mount your *WATERBACK*, follow these instructions:

1. Check fit. This unit is designed to fit tightly across the top of your Vision recumbent seat. Due to manufacturing tolerances the fit of the "pocket" over the seat back may be tight or *very tight*.

2. Slide the "Pocket" over the seat back.. Pull the pocket of the *WATERBACK* over the top of the Vision seat. If the fit is too tight to easily pull into place, you can pull the top strap on the seat tighter (temporarily) to ease the installation. Once the pocket is settled in place, reach inside from the back and re-set the top seat strap to its normal position. If you have an older (pre 1999) Vision seat fabric without the "belt" style straps, you can brace one seat rail against a wall and lean on the other seat rail to get the needed clearance to install the *WATERBACK*.

3. Attach the lower section. Thread the end of the *WATERBACK* bib outside of the seat fabric and inside of the seat frame rails. Loop the end strap around the seat base strap and fasten the velcro. You can now install your water bladder and tools.



Accessories - KSGizmo Kickstand adaptor plate

The KSGizmo kickstand adaptor plate is designed to work with the Greenfield BottomBracket 305mm kickstand (not included).

If you are uncomfortable with the operation of your quick release units, please see your local bike shop.

The KSGizmo (Gizmo) will allow you to attach the Greenfield BB kickstand (305mm version) to most *single* Vision recumbent bicycle.

This will fit ANY generation 40 series or 50 series Vision, and 2002 and later 60 series bikes.

We do not recommend this unit for the tandem.

To mount your Gizmo:

1. Check your parts. You should have a kickstand Gizmo plate, one 5x16mm SS bolt and 5mm washer, and one 3/8"-16 x 1"bolt.

2. Attach the Kickstand to the Gizmo. Remove the bolt, washer and upper plate from the kickstand. Set aside the long bolt and upper plate, and attach the kickstand to the plate using the original lockwasher and the 3/8" bolt we provide. Tighten securely.

3. Attach the Gizmo to the frame. Remove the rear QR skewer from the bike. DO NOT remove the wheel!. Thread the skewer through the Gizmo and into the axle on the left dropout. Line up the threaded hole in the dropout with the appropriate (see fig 2) hole in the Gizmo and loosely install the 5 x 16mm SS bolt and washer through the Gizmo into the threaded hole in the dropout. .

4. Tighten everything. Tighten the QR skewer first, and then tighten the 5mm bolt.

Racks and fender struts should be installed outboard of the Gizmo, using the 5mm bolt. You might need to use a longer 5mm bolt than the one supplied.

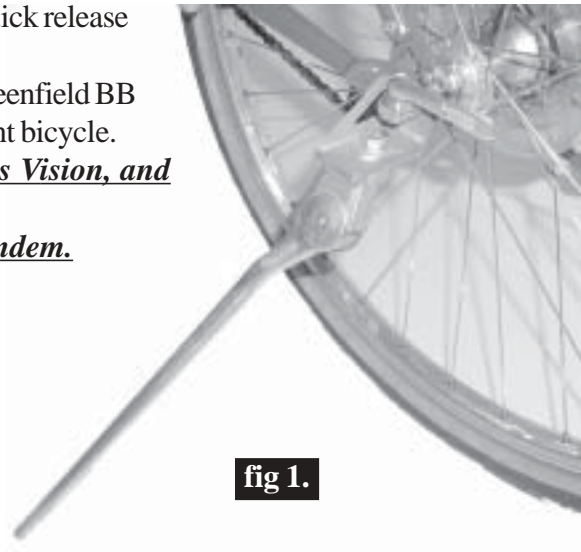

fig 1.

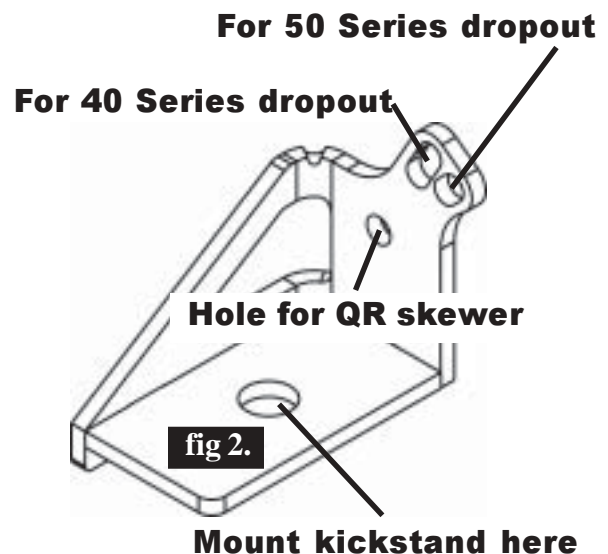
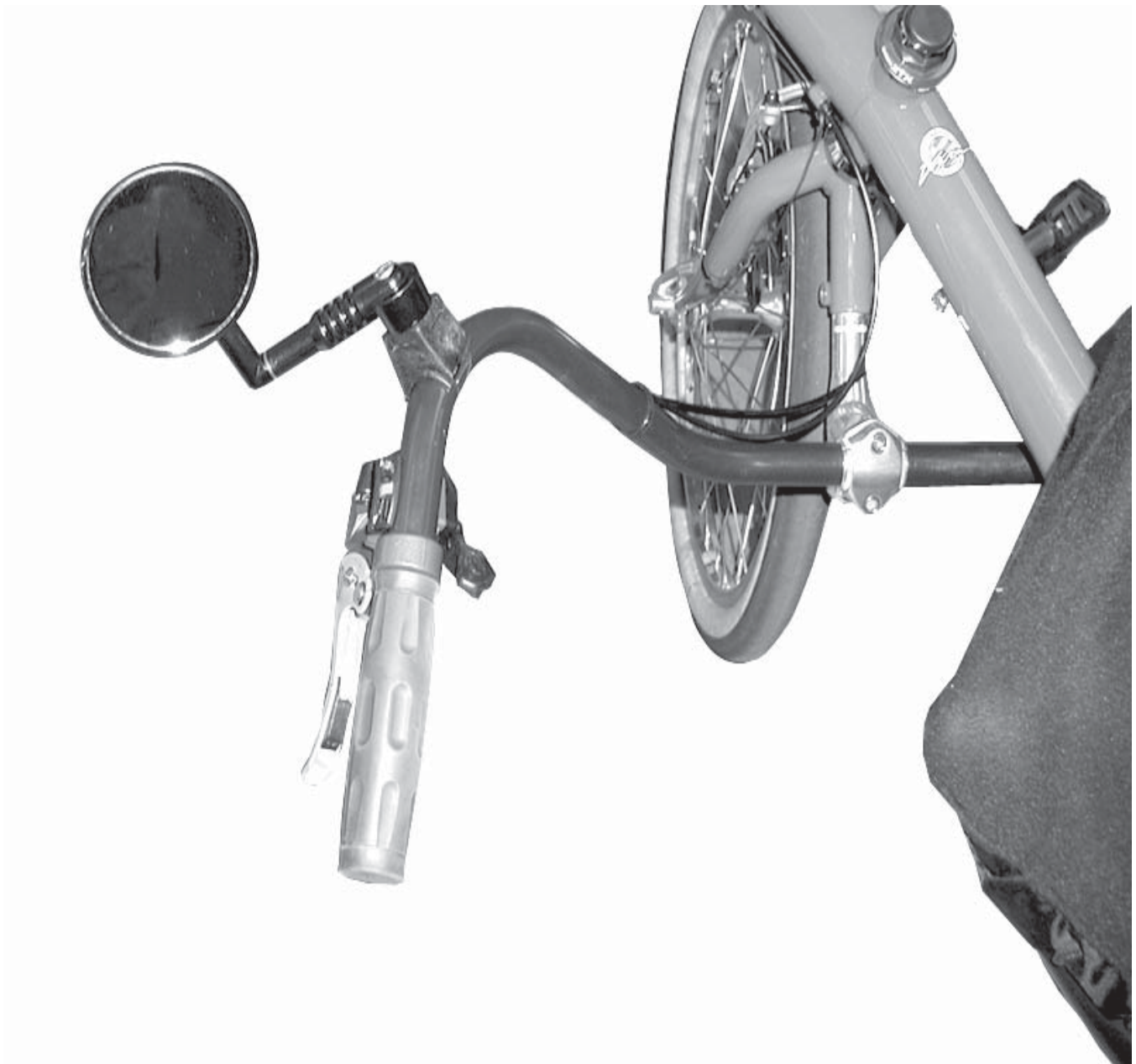

fig 2.

Accessories - MR40 Handlebar Mirror

This Mirror is designed to fit all Vision Recumbent bicycles that are equipped with under-seat handlebars. Over-seat handle equipped bikes can use any mountain bike-style bar end mirror. These instructions are for the typical left-side mount, but this mirror will mount to either side of the handlebars.



Accessories - MR40 Handlebar Mirror (cont.)

This Mirror is designed to fit all Vision Recumbent bicycles that are equipped with under-seat handlebars. Over-seat handle equipped bikes should use the MR40T mirror. These instructions are for the typical left-side mount, but this mirror will mount to either side of the handlebars. We have included an allen wrench for the two mirror stalk adjustments. You will also need a 5mm allen wrench (not included) for the main mounting bolt.

1) Check your parts! (Fig. 1). You should have a mirror attached to a "stalk" mount, a 6mm x 35mm bolt, a square mounting block and a strap clamp **WITH** nut.

Please note: the square nut on the strap clamp can fall out! Don't lose it!



2) Disassemble the unit by turning the bolt out of the strap clamp completely.

3) Open the strap-clamp, and wrap it around the handlebars as shown. The typical mounting location is left side, just ahead of the controls. Again, be sure to not lose the square nut held by the strap. (Fig 2)



3) Slide the square mounting block down onto the strap, being sure to align the curvature of the base of the block against the handlebar appropriately. (Fig. 3)



4) Thread the attachment bolt through the mirror stalk, through the square mounting block and into the square nut on the strap clamp. (Fig. 4) Tighten moderately, and adjust the mirror for best viewing.

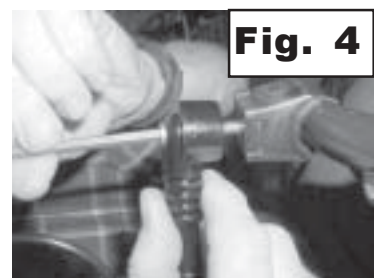

Swing the handlebars from side to side and check for any interference between the mirror (or its mount) and the seat. Readjust as needed. Check the bolt periodically for tightness. The Mirror should not move by itself, but you should be able to adjust it as needed. Do not adjust while riding!

Accessories - VFM40 Fairing

Fits Vision 40swb, 50, 60 and 80 series bikes.

Does NOT fit R32 or R40LWB/MWB

Congratulations on your purchase of the Vision VFM40. This fairing offers excellent weather protection and will dramatically improve the aerodynamics of your Vision.

The VFM40 is designed to fit the Vision 40. 50. 60 and 80 series bikes.

Note: This unit will not fit a Vision R30 or R32.

To install the VFM40 on your Vision, please follow these directions carefully. Before you start, make sure your boom has been adjusted correctly for your leg length. If you are new to the bike, it would be a good idea to ride it for several days to make sure your boom adjustment is correct prior to installing your fairing.

Remove the black plug from the end of the front derailleur support tube. Slide the fairing mounting stem into the tube. If it does not fit, try carefully loosening the front derailleur clamp, or looking for irregularities inside the support tube. After the stem is in place, be sure to retighten the front derailleur clamp securely.

Insert the stem at least to the *minimum insertion* mark, align the stem facing directly forward and tighten the wedge bolt securely (the 6mm hex bolt accessed through the top of the stem)

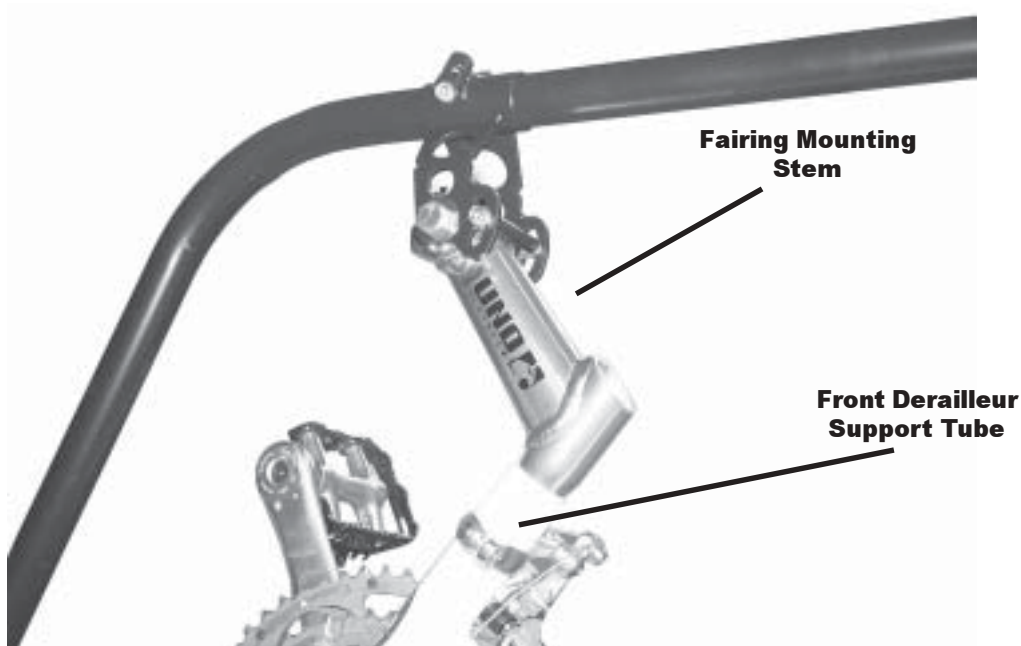

Accessories - VFM40 Fairing (cont.)

Carefully remove the bubble from its box. Pull the protective paper away from the mounting holes. Unroll the bubble and lay it out on the frame. Slide a nylon washer and then a rubber washer onto a nylon screw, and insert through the bubble material. The rubber washer should be contacting the bubble. Install a rubber washer on the other side of the bubble, and thread the screw through the fairing frame. Slide another nylon washer onto the screw (outside of fairing frame) and loosely screw a nylon nut onto the end of the bolt on the inside of the frame mount. Loosely install one bolt in each of the three mounting points, spreading the fairing to fit, then install the last three bolts in the same manner. Tighten all the bolts four full turns. Do not over-tighten.

Make sure the mounting stem is aligned pointing forward.

Sit on the bike and pull the fairing bubble edge down. The top edge of the bubble should line up with your shirt collar. Get off the bike and set the rear travel stop against the mounting stem, limiting the rearward travel of the bubble to the appropriate point. Tighten the travel stop bolt.

Tighten the stem mounting bolt to the point where the bubble will move forward when you apply pressure to the top edge.

Loosen up the frame slider bolts, then sit on the bike. Slide the bubble and frame slider back or forth to get adequate clearance from your body or the handlebars on over-seat steering models. Flip the bubble up into the dismount position and check clearance between the pedals and the bubble. When you have the fore and aft position of the bubble correct, tighten the frame slider bolts. Recheck all bolts and fittings before every ride.

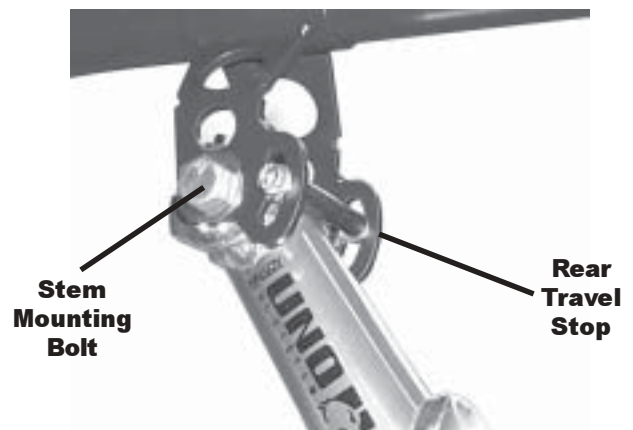
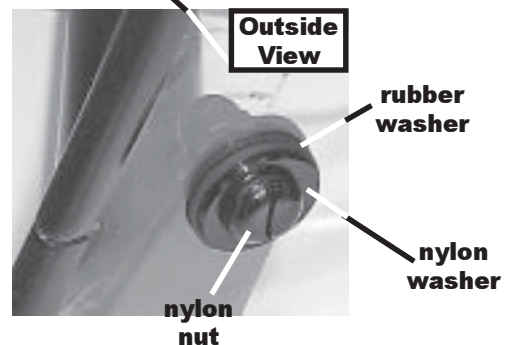
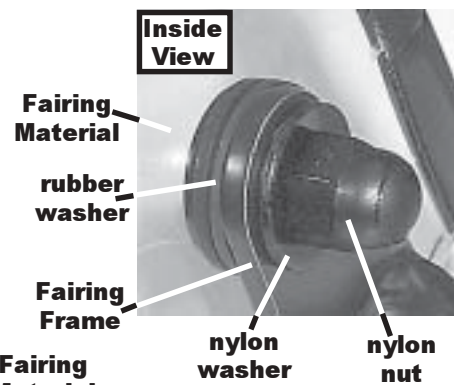
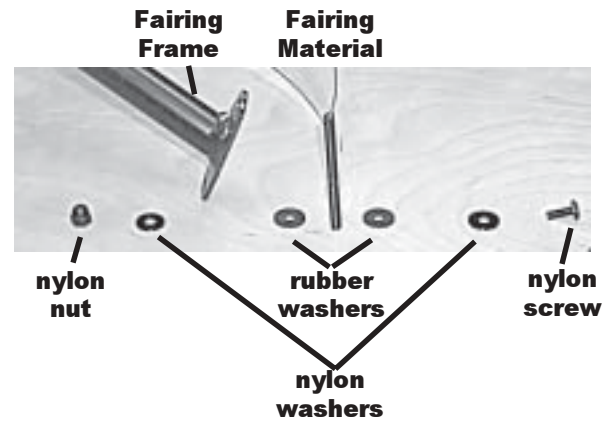

Accessories - VFM40 Fairing (cont.)

To mount your bike with the VFM40 in place, tilt the bubble forward by grasping the top edge and applying upward pressure.

If you have over seat steering, tilt your handlebars forward as well.

Sit on the bike and pull the bubble back down against the travel stop.

The top edge of the bubble should be level with your shirt collar—you look over the fairing, not through it.

You should have enough clearance between the fairing and over seat handlebars to allow for full lock turns, as well as pedal and foot clearance. If you can not set the bubble up to get foot and handlebar clearance, do not ride the bike, see you local Vision dealer.

Warranty

Your VFM40 comes with a limited warranty.

The Bubble is warranted against defects in materials or workmanship for 30 days from date of purchase. The frame is warranted for one year from date of purchase. All warranties, written or implied, are for the original purchaser only, and only cover replacement or repair of the item. This warranty only applies to the VFM40 system purchased through ATP, Inc (Vision Recumbent Bicycles).

You must call ATP, Inc. for a return authorization number, and then send the item(s) in question back to us, postage paid. Upon examination, we will repair or replace them, at our discretion.

We also offer a "no questions asked" exchange policy. If your fairing bubble or frame is damaged in any way whatsoever after the warranty period expires, we will replace it for a \$100 flat fee. All you have to do is call us for a exchange number, return the damaged item to us (postage paid) with a money order for \$100 for each fairing bubble **OR** frame exchange requested, and your receipt. We will send you a new unit. This exchange program is good for life to the original owner.



FAQ's

There's always a lot of questions asked.

Here are some of them.

If you are wondering who the ideal customer for a recumbent is.... It's anyone who wants a comfortable, safe, fun and fast ride.

These are excellent bikes for any road use: Touring, commuting, general sport riding, long distance training... anything and everything.

These bikes fit most rooftop and many "receiver hitch" style car carriers.

SPD's work great on Vision bikes.

What is this bike all about?

The Vision is a recumbent, designed to be the most comfortable bicycle you have ever ridden.

Is it really comfortable?

Just look at the seat, and imagine riding down the road in a nice comfortable chair. Add the fact that there is no weight on your hands and you get to look ahead at the scenery, not at your front wheel—yes, they are very comfortable.

Are they fast?

All bikes are only as fast as the rider, but on a Vision recumbent you have a distinct aerodynamic advantage over the typical rider on an upright bike.

Every human-powered land speed record is held by recumbents, including the DuPont prize for exceeding 65 m.p.h. on a flat course.

Can they climb hills?

Yes—the position is very efficient. Even without the ability to stand up you can apply tremendous power to the pedals by bracing against the seat back. If you are a racer who can maintain a standing sprint on hills, you probably will climb a little slower on a recumbent, but if you tend to downshift and spin your pedals to get up hills, you'll be every bit as fast on your Vision as you were on your upright bike.

FAQ's

It's always a good idea to carry catalogs along for a ride. Otherwise you spend all day talking, not riding.

No, they are not hard to ride, yes, they are comfortable.

**R40/R44/R45
R50/R54/R55
R64/R65/R68
all accept standard rear racks for panniers.**

**R82/R85
accept standard racks with our rack adaptor kit.**

I've never seen these before—why?

In 1932, a French racer on a recumbent shattered a 20 year-old world speed record. The officials in charge of international bicycle racing immediately banned all recumbents as an “unfair advantage” and denied the record. Without the racing circuit to help market the bikes, recumbent development ended—until recently.

Are recumbents safe?

Very safe. You get to ride along feet first, not head first. If you do drop the bike, you have much less distance to fall than on a conventional bike.

What about touring?

Vision recumbents are the best bikes for touring—period. The comfortable position and great “heads-up” view can make your next tour the best yet. Vision bikes accept rear racks and pannier sets. You can even tow a Bob or Burley trailer with your Vision.

How can I carry this bike?

Vision recumbents will fit most standard roof and trunk racks. The tandems and long wheelbase Visions require a tandem roof rack.

Is a Vision difficult to maintain?

All of the components used by Vision are standard for the bicycle industry. The brakes, gears, tires, cables, and chains can all be maintained or replaced by any bike shop, anywhere.

Bike Designs

Many different bikes for different people.

Ride the different models yourself to get familiar with them.

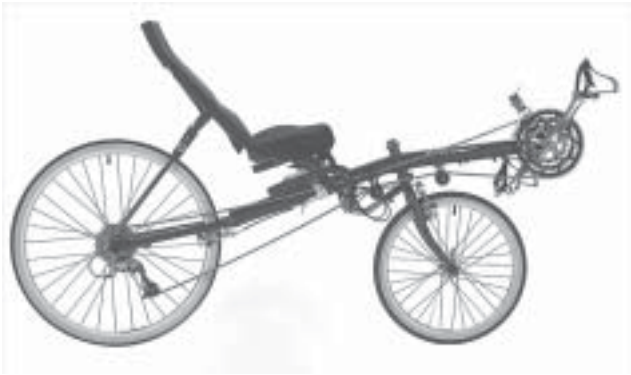

SWB - Short Wheelbase

There are many different recumbent designs available, each different in what they offer the rider. Vision is a company unique in its diversity, manufacturing a wide variety of recumbent styles.

There are two major aspects of recumbent design that are used to define the majority of recumbents available today: wheelbase and handlebar position.

Wheelbase refers to the distance between the axles of the bicycle. In general, there are three different styles of bikes defined by wheelbase.

Vision short-wheelbase bikes have a wheelbase of approximately 40". These bikes are our most popular models. They are the lightest design we make, have snappy handling characteristics, and fit onto car transport racks easily.



MWB - Medium Wheelbase

Vision medium-wheelbase bikes run about 60" from axle to axle. These bikes are very easy to ride, and have a feel very similar to standard upright bikes.

Bike Designs



OSS - Over-Seat Steering

The other major design aspect of recumbents is the handlebar position.

Some bikes have over-seat steering, with the handlebars up in front of you. This can be a very 'natural' feeling position for a rider used to upright bikes, and is typically the most aerodynamically efficient.

The other handlebar design style is under-seat steering, where the handlebars are mounted beneath the seat. This position is very comfortable, since your arms are resting in a relaxed position. The inherent width of the under-seat style also leads toward gentle handling characteristics.



USS - Under-Seat Steering

Except for the the Saber series, wich are over-seat steering only, all of our bikes are available with either handlebar system, and can be converted at any time if the customer wishes.

It's important to remember that no one style is inherently better than others, which is why we build them all, to meet the personal preferences of hte customer.

Fitting and Demos

There are two methods used to fit our bikes to the rider:

- 1) Sliding Seat:
Found on the stoker position on our tandems.**
- 2) Sliding nose boom:
All other VisionBikes.**

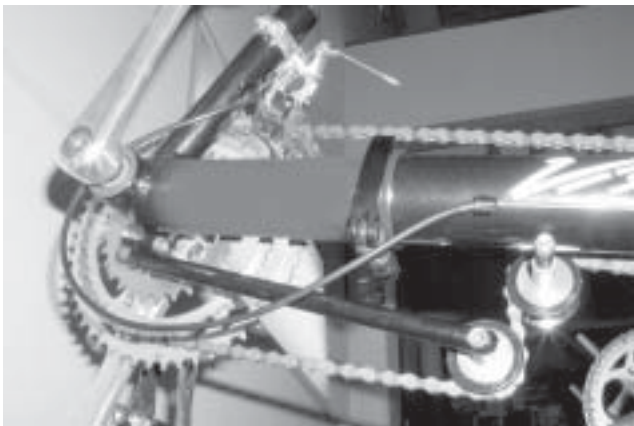

Unlike upright bikes, Vision recumbents are not prejudiced against female riders.



To get someone to buy a Vision, they have to try a Vision (you too!).

We use two different methods for adjusting a bike to fit the rider.

On the stoker seat of the tandem, we use a sliding seat assembly. Simply loosen the QR skewers, and slide the seat to an appropriate position. The proper leg length setting is the same as it is on an upright bike... leg extended but not locked.

For 2002, all of our bikes (except the tandem) feature the Instqant-Adjust boom. To set the bike to fit a rider, loosen the QR skewer on the boom and slide the crank until the rider's outstretched heel is against the pedal. Tighten the skewer and you are ready to ride.

Unlike upright bikes, Vision recumbents are not prejudiced against female riders. Since the rider does not carry any of their weight with their hands, the traditional fitting issues about stem and top tube length do not apply. Everyone can be comfortable on a Vision.

Fitting and Demos

If the customer has never been on a recumbent before, try the seat back angle at the full forward position. If they have had recumbent experience, set it in the middle of the adjustment range.

Adjust the bike to fit the customer's leg length.

Choose a large test ride area with as few obstacles as possible. Make sure the customer is lined up on a long straight section at the start so they don't have to turn right away.

Stand behind the seat, straddling the rear wheel, and hold the bike for the customer by grasping the top of the seat back.

Have the customer sit in the seat and grab the brakes. Some riders will try to sit forward in the seat - make sure they lean back and relax!

Brief them on the starting technique; one foot on the ground, the other on a pedal at a 12:00 midnight position. Just give a good push on the pedal to start.

Assure the rider that the VISION is a real bike, and their normal instincts will take over. They should not be putting any weight on the handlebars - tell them to *RELAX*, don't tense up — you may have to repeat that!

Make sure the customer is looking forward normally, and not staring at their feet. Start them forward, holding on to the bike and moving with them. After a few feet you will be able to tell if they "get it" — more than likely they will just ride away and come back all smiles! Tell them to *RELAX*.

Occasionally a rider just can't seem to get the hang of a recumbent their first try. The wife of one of the engineers, who now has over 15,000 miles on her VISION, couldn't ride her recumbent the first day she tried. The second day she got on and rode right off - assure your customer that a bit of time to "think about it" might work.

Make sure you go over the unique features of the VISION with your customer, and try different adjustments such as seat back angle and handlebar position.

Instant-Adjust

The New Size Adjustment System from Vision Bikes

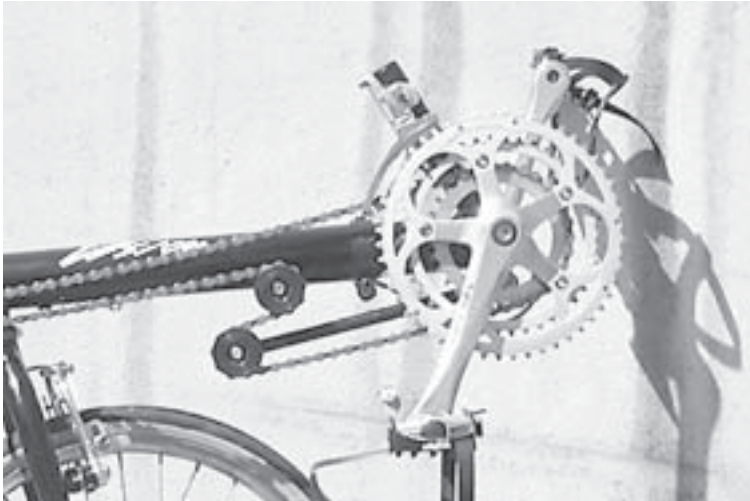

For 2002 Vision Recumbent Bicycles is producing the new Instant-Adjust system, and it is a stock item on all of their recumbent bikes (excluding the R82 and R85 tandems).

When assembling the bike, the dealer simply installs the stock length chain supplied (no cutting or fitting) and the bike is ready for the floor for sale or demonstration.

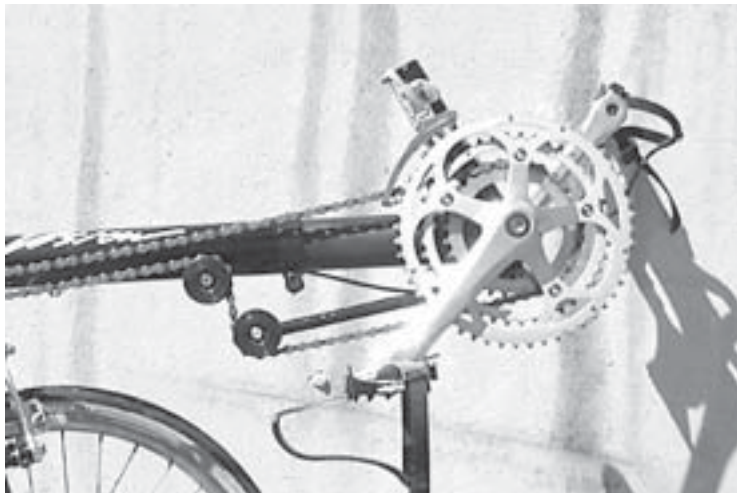

To fit the bike to someone, a single quick-release lever is opened and the nose boom can be moved to set the pedal against their outstretched leg. Tighten the quick-release and the bike is ready to ride.

There is an index tab built into every boom to keep things aligned, and the built-in chain adjustment system keeps the drivetrain working perfectly with no chain adjustments needed. The system can be removed for customers that do not want it.

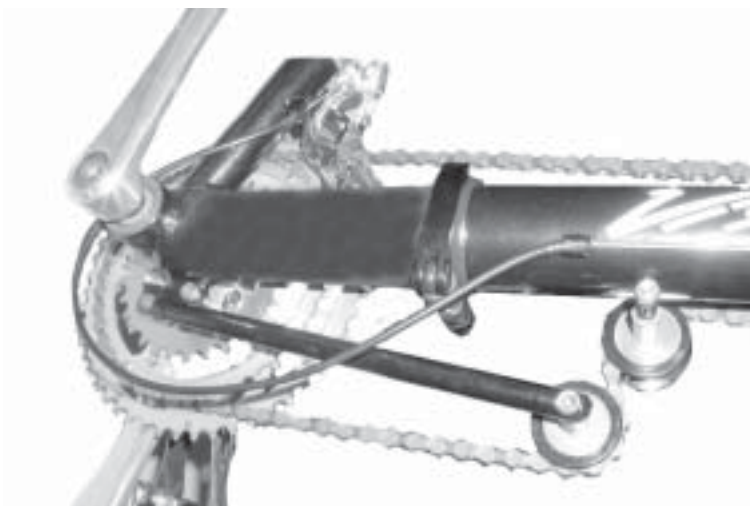

Shops will no longer have to deal with separate QR kits, chain cutting, or greasy hands.

Bike Overview

R40 Series

***Rigid Frame sport/touring bikes.
Over or Under seat steering.
Standard and small frames
available.***

***Suspension front fork optional.
R40 is short or long wheelbase
16" Front - 26" Rear - Small frame.
20" Front - 26" Rear - Standard frame.***



R50 Series

***Full Suspension sport/touring.
Over or Under seat steering.
20" Front - 26" Rear***



R60 Series

***Ultra performance speed bikes.
Dual 26"***



R80 Series

***Tandems
Suspension front fork optional.
Over or Under seat steering.
20" Front - 26" Rear***



Wheel Sizes

**16" 349 bead-seat
R40, R44 and R45
Small frame front wheel**

We use standard, widely available sizes of wheels whenever possible on our bikes. This assures customers of a good selection of replacement tires and rims.

We have worked with tire manufacturers to produce high quality tires in some of these sizes, when there were none available.

We feel that a customer should be able to get a tire that fits their bike anywhere they happen to be in the country. This way, no one is ever left stranded.

**20" 406 bead-seat
BMX standard
All front wheels except
R60 series Sabers.**

Our smallest front tire is a 16". This is used on our Small-frame R40, R44 and R45 bikes. This is a 349 bead-seat tire. The high pressure unit from Primo is rare, although we keep them in stock here. However, this is a standard juvenile bike size, so if anyone is desperate for a tire, they can always find one at any mass merchant.

**26" 559 bead-seat
Mt. Bike standard
All 40 series rear
All 50 series rear
All 80 series rear**

Our typical front tire is a 20". We elected to use a 406 bead-seat size, which is the BMX standard. Once again, high-pressure units are not common, but tires that fit this wheel can be found anywhere.

**26" 571 (650C)
bead-seat
Time Trial size
R60 series Sabers front
and rear.**

Our standard rear tire is 26". We are using the 559 bead-seat size, the Mountain bike standard. High pressure units in this size are common, and replacement units can be found anywhere.

Our R64, R65 and R68 Saber series bikes use a 26" wheel front and rear. This is the 571 bead-seat size. There are excellent high pressure tires in this size developed for the time-trial circuit.

Recumbent History

Racers crushes 20 year old world record on recumbent bike.

Officials have a snit and outlaw the design for being an “unfair advantage”.

Design development halts.

Recumbents are hardly a new fad, they have been around since the 1850's. Probably the biggest reason for the dominance of the “upright” design has been due to an old controversy on the professional racing circuit. In the early 1930's a second category racer beat the French national champion and shattered a 20 year-old record riding a recumbent. The UCI promptly declared the recumbent ‘not a bicycle’ and denied the record.

Without the marketing support of racing, the recumbent style was not picked up and developed by manufacturers.

Over the last two decades recumbents have been gaining popularity in this country. Unfortunately, up until now, the small-scale production of the typical recumbent builder has kept the availability poor and the prices high.

Francis Faure Breaking the World “Hour” Record, 1933

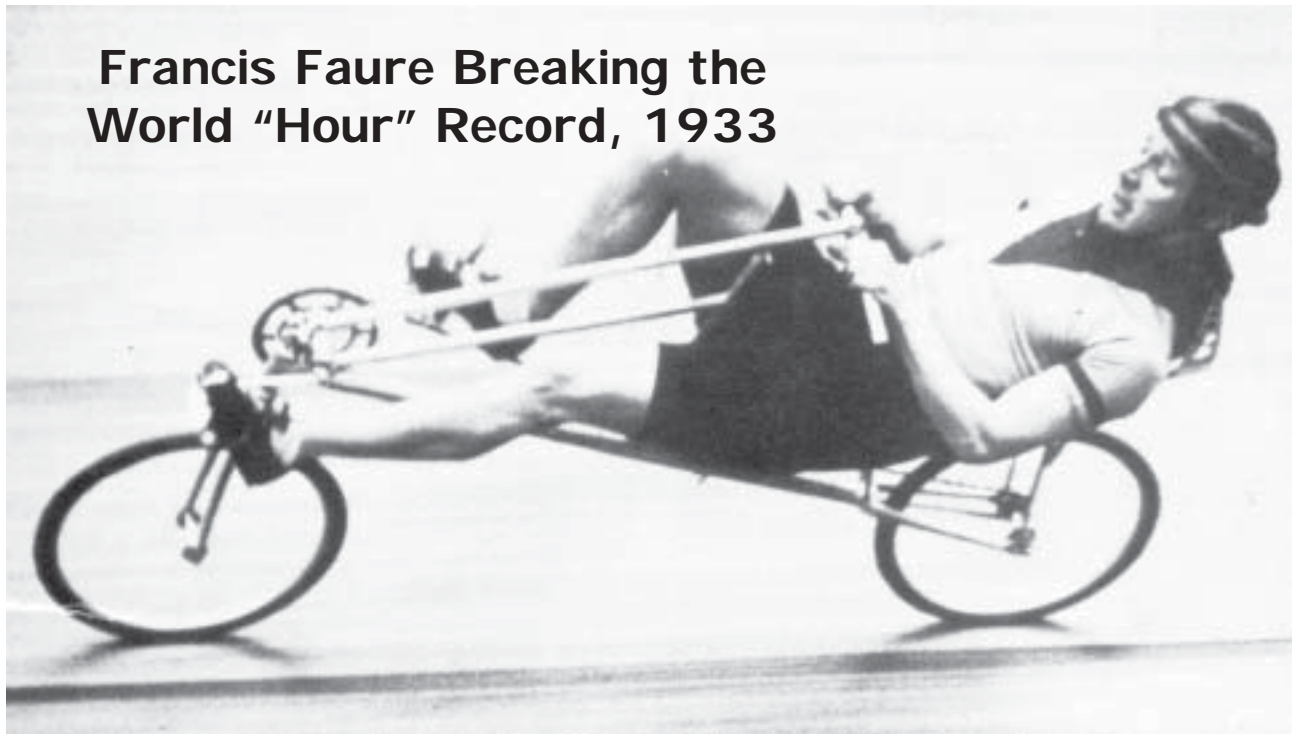

Vision introduces the next generation of Comfort Bikes; **The V70 and V72** **“Thoroughbred” uprights.**

Known for its line of Vision Recumbent Bicycles, ATP is now expanding their bicycle line to include upright bicycles.

“Comfort Bikes are the newest growth market in our industry, but most companies are not doing enough to truly improve the comfort of upright bikes”, according to Joe Smith, President of ATP, Inc. “You can simply bolt on a big saddle or wider handlebars, but we wanted to do something that would make a real difference in the bike”.

With their experience in recumbent design, ATP is well versed in comfort. The desire to expand their product line with more mainstream products, coupled with some real ground up design work has lead to the development of the new V70 and V72 bikes.

“Your typical rider wants a bike that they can ride without the discomfort of supporting a large portion of their weight on their hands. They want to be able to easily reach the ground from the saddle. They want a bike that is easy to mount and dismount, and they want to see where they are going” continues Mr. Smith.

“We have studied tradition bicycles extensively, and also have a lot of experience with the recumbent riding position. What we have done with the 70 series is to rotate the rider’s traditional upright position back 22 degrees, and moved the seat, handlebars and crankset appropriately. We now have the saddle low enough to the ground to reach, when the seat to crank position is set correctly. We’ve reduced the weight on the rider’s hands, and lifted their head up enough to give them a better view.”

The V70 has a suggested retail price of \$695, and the upgraded components on the V72 will generate a retail price of \$859. Available now.



Comparing traditional bikes to the V70 and V72 “Thoroughbred”

Traditional Bikes ***Thoroughbred***

Have a high top tube and saddle, making it difficult to get on and off the bike.
Has a lower top tube and seat, for a much easier mount and dismount.

Traditional Bikes ***Thoroughbred***

Have a high seat, making it impossible to reach the ground without dismounting.
Even with the seat adjusted properly, the rider can reach the ground easily from the seat.

Traditional Bikes ***Thoroughbred***

Place a lot of weight on the rider’s hands, wrists and shoulders, causing discomfort.
Has an upright seating position which takes most of the weight off the riders hands.

Traditional Bikes ***Thoroughbred***

A rider often has to crane their neck to see the road and scenery.
Upright seating position allows for a better view without neck discomfort.

Traditional Bikes

Transfer a lot of weight to the front wheel during braking, which can cause the rear wheel to skid, and can even “pitchpole” under heavy braking, tossing the rider over the handlebars.

Thoroughbred

Has the rider lower and further back, improving braking and making for a safer ride.

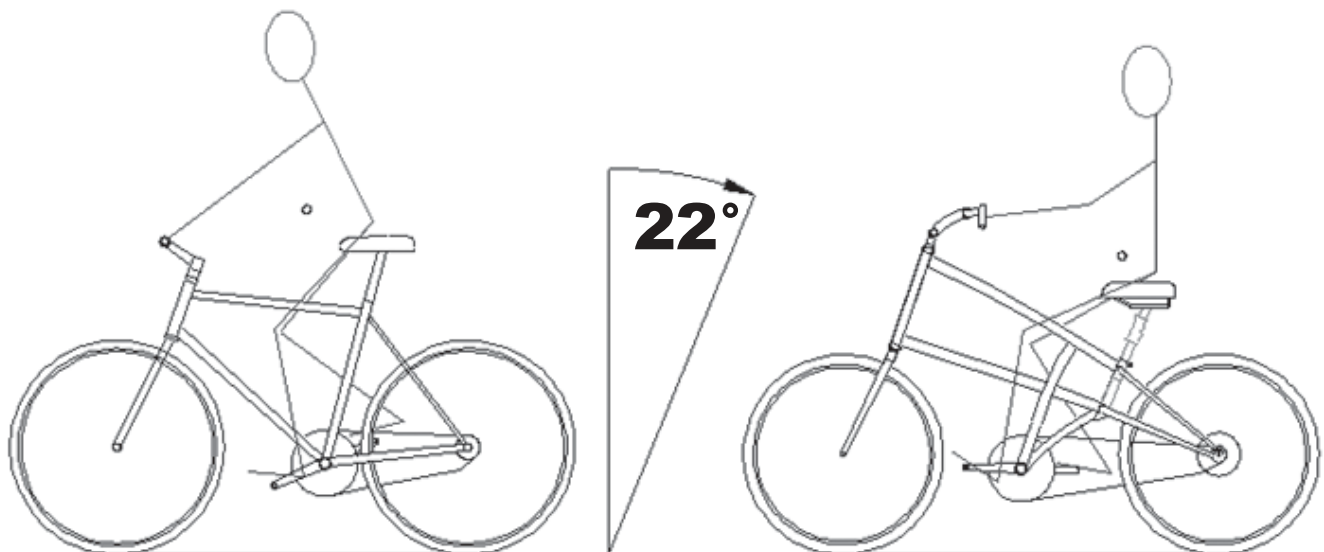

By rotating the rider’s position back about 22 degrees, we’ve stepped “outside the box” in bicycle design, and given those riders who prefer an upright bike real advantages in comfort and safety.

The Present

Seattle crew develops Vision Recumbent Bicycles.

Modern “just-in-time” manufacturing techniques produce a lot of bike for the money.

Company grows out of their garage and into the future.



**1992
Grant's
Garage**

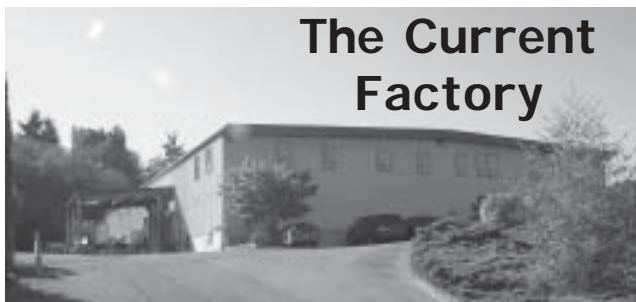

**The Current
Factory**

Advanced Transportation Products, Inc. (home of Vision Recumbent Bicycles) was incorporated in October 1992 by Joel Smith, Grant Bower and Greg Bower. The goal of the company was to manufacture recumbents using modern production methods, providing the quality and value of any mainstream bicycle.

Joel, then a structural engineer for the Boeing Company, had been designing and selling the R-20, his own recumbent bicycle, since 1990.

Grant, also an engineer, had been designing his own recumbent bikes since 1985, and has received many awards and honors at the yearly International Human Powered Vehicle Championships.

By 1992 there were signs that the recumbent market was starting to grow, and Grant and Joel decided to put their design and production experience together to produce a recumbent with all the quality and features of any production bike. To pull this off, they joined forces with Greg Bower (yes, it's Grant's brother), who has extensive experience in property management and business finances.

The company has grown from its humble beginnings (literally in Grant's basement) to its current 20,000 square-foot location, with 32 employees. We now produce 10 different models, spanning a price range from \$1095 through \$4995.

Notes

Advanced Transportation Products, Inc
Mailing: P.O. Box 249
Shipping Only: 6304 215th St SW
Mountlake Terrace, WA 98043
425-673-2448 Fax 673-4668