

## 01 / Set Up Your Camera

1. Position your camera's adjustable stand for setup.

Note: Peel off film from the camera before use.

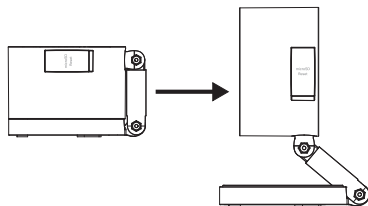

2. Download the Tapo app from the App Store or Google Play.



3. Power up the camera. Tap the ⊕ button in the app and select your model. Follow the app instructions to complete setup.

## 02 / Install Your Camera

### Option 1: Set on a table or shelf

1. Place the camera on your desired table or shelf.
2. Adjust the stand angle to the notch position in the base for more stability.

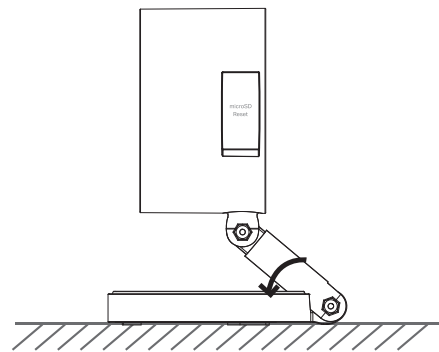

### Option 2: Mount to metallic surfaces

The camera has a magnet in its base, allowing magnetic attachment to metallic surfaces.

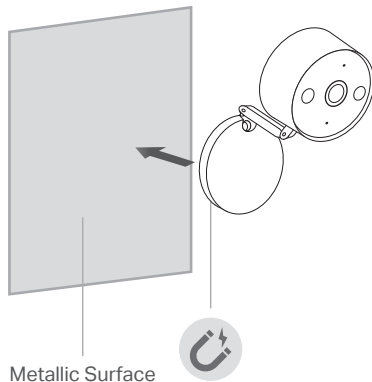

### Option 3: Stick to a clean wall

1. Attach the included adhesive to the back of the metal plate properly.

Note: The adhesive is for one-time use. Avoid re-using the adhesive to ensure its adhesion.

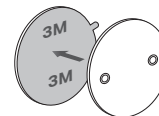

2. Wipe off the dust from the surface, stick the metal plate with the adhesive to the clean wall, and press it down for 15 seconds to ensure the plate is firmly attached. Then attach the camera to the plate.

Note: This is applicable with tile, glass, marble, metal, stainless steel, and hard wall surfaces.

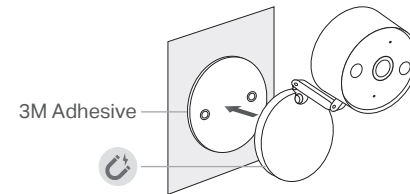

### Option 4. Mount to the wall (with or without the metal plate)

1. Stick the mounting template to the desired mounting place. Drill **two** holes according to the template.

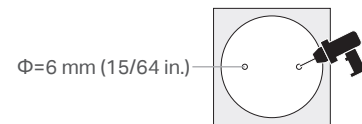

2. Insert two anchors into the holes and use the screws to affix the **metal plate** over the anchors. Then attach the camera to the plate.

Note: Ensure the metal plate's concave-holed side faces the magnetic base.

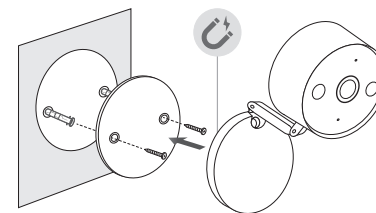

1. Drill **one** hole in the desired mounting place.

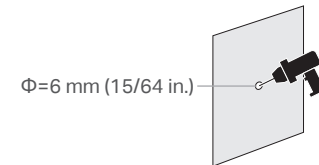

2. Insert one anchor into the hole, use one screw to affix the **camera** over the anchor, then tighten the screw.

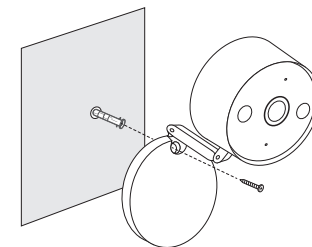

## 03 / Power Up Your Camera

1. Firmly plug in the power connector to the power port of the camera, and ensure no gap exists.

Note: To identify if the power connector is connected properly or not, you can refer to

<https://www.tp-link.com/support/faq/3761/>



2. Fix the power cord with adhesive tape or the provided cable clamp and screw.

Note: To ensure a firm connection, fix the power cord at a distance of about 25 cm away from the power connector.

Adhesive Tape

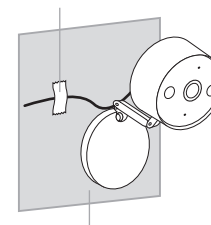

Metallic Surface

Cable Clamp & Screw

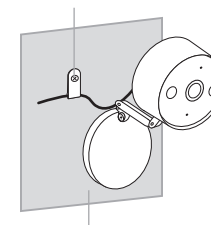

Wall

# Appearance

## Front

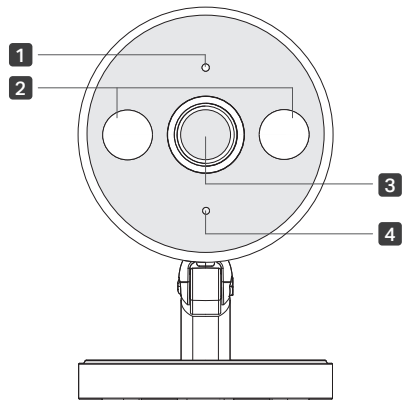

- 1** System LED
- 2** White Lights
- 3** Lens
- 4** Microphone

## Back

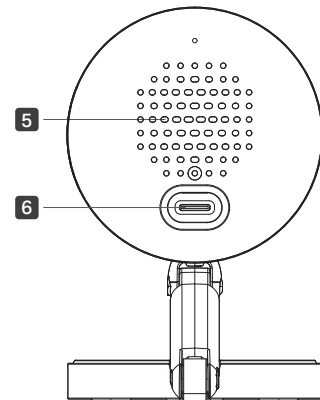

- 5** Speaker
- 6** USB Type-C Power Port

## Side

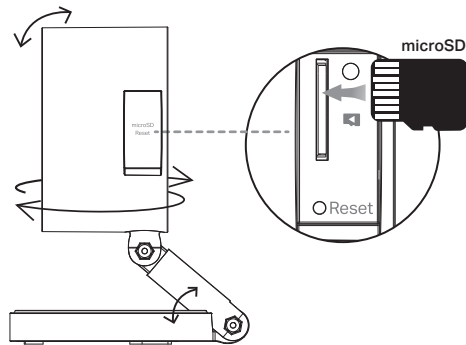

### Adjust View

Tilt and rotate the camera and stand for your desired viewing angle.

### microSD Card Slot

Open the cover. Insert a microSD card (not included) and initialize it on the Tapo app for local recording.

### Reset

- Use a pin to press and hold for **5s**: Reset Wi-Fi settings
- Use a pin to press and hold for **10s**: Reset to factory settings

# System LED Indications

<b>Solid red</b>	Starting up
<b>Blinking red and green</b>	Ready for setup
<b>Blinking red slowly</b>	Connecting to Wi-Fi
<b>Solid amber</b>	Connected to Wi-Fi
<b>Solid green</b>	Connected to the cloud
<b>Blinking red quickly</b>	Camera resetting
<b>Blinking green quickly</b>	Camera updating



Visit [www.tapo.com/support](https://www.tapo.com/support) for technical support, user guides, and more information



# Safety Information

- Do not use damaged charger or USB cable to charge the device.
- Do not use any other chargers than those recommended.
- Do not use the device where wireless devices are not allowed.
- Adapter shall be easily accessible.
- Use only power supplies which are provided by manufacturer and in the original packing of this product. If you have any questions, please don't hesitate to contact us.
- Keep the device away from fire or hot environments. DO NOT immerse in water or any other liquid.
- Do not disassemble, repair or modify the product.
- Do not use the product if the casing has been broken. Danger of electric shock.
- Never touch the product with wet hands.
- Do not place near automatically controlled devices such as fire alarms. Radio waves emitted from this product may cause such devices to malfunction resulting in an accident.
- Observe restrictions on using wireless products in fuel depots, chemical plants or when blasting operations are in progress.
- Do not use liquid to clean the product. Only use a dry cloth.
- Never put metal objects inside the product. If a metal object enters the product turn off the circuit breaker and contact an authorised electrician.
- This product is not intended to be used when providing medical care. Consult the manufacturer of any personal medical devices, such as pacemakers or hearing aids to determine if they are adequately shielded from external RF (radio frequency) energy.
- Do not use this product in health care facilities. Hospitals or health care facilities may be using equipment that could be sensitive to external RF energy.
- Do not place heavy objects on top of the product.
- When you leave the product unused for a long time unplug the product from the power outlet.

- This product may interfere with other electronic products such as TV, radios, personal computers, phones or other wireless devices.
  - Adapter should be used indoors where the ambient temperature is lower than or equal to 40 °C.
  - Operating Temperature: -20 °C ~ 45 °C (-4 °F ~ 113 °F)
  - When mounting the camera magnetically, we recommend installing it no higher than 2 meters.
- Please read and follow the above safety information when operating the device. We cannot guarantee that no accidents or damage will occur due to improper use of the device. Please use this product with care and operate at your own risk.

TP-Link hereby declares that the device is in compliance with the essential requirements and other relevant provisions of directives 2014/53/EU, 2009/125/EC, 2011/65/EU and (EU)2015/863. The original EU declaration of conformity may be found at <https://www.tapo.com/support/ce>

TP-Link hereby declares that the device is in compliance with the essential requirements and other relevant provisions of the Radio Equipment Regulations 2017. The original UK declaration of conformity may be found at <https://www.tapo.com/support/ukca/>



# Quick Start Guide

Indoor/Outdoor  
Home Security Wi-Fi Camera

## Setup Video

Scan QR code or visit  
<https://www.tp-link.com/support/setup-video/#cloud-cameras>

