

simple lunch bag *pattern*

by Ellen Lockett Baker

Finished dimensions:

9" x 9" x 5 1/2"

Supplies:

Canvas: 1/2 yard

Coated cotton: 1/2 yard

Batting: 1/2 yard

Magnetic snap

1" cotton webbing: 30"



Step 1: CUT FABRIC.

Cut fabric to the following dimensions:

Canvas: 10" x 26 1/2", cut 1*

Coated cotton: 6 1/2" x 10", cut 4

10" x 26 1/2", cut 1

Batting: 10" x 26 1/2", cut 1

**If using a directional pattern, you will need to cut two pieces (10" x 13 3/4" each), sew them right sides together and press the seam open. This will make a seam at the bottom of the bag, but will allow your fabric to be facing in the right direction on both sides.*

Step 2: BASTE BATTING.

Attach the batting to the wrong side of the canvas piece by pinning and basting it in place 1/4" from the edge.

www.thelongthread.com

For personal use only.

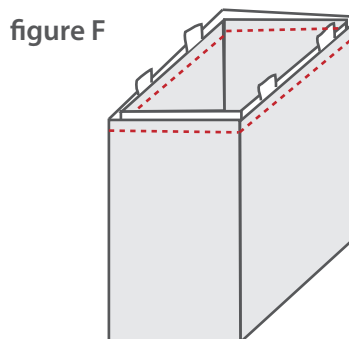
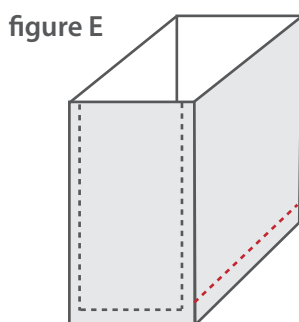
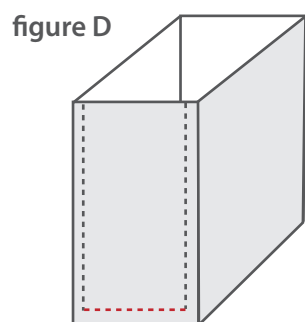
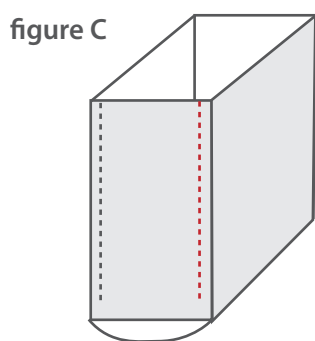
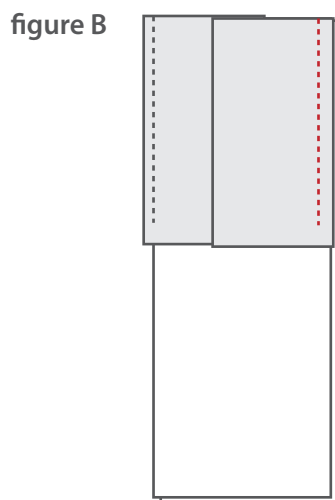
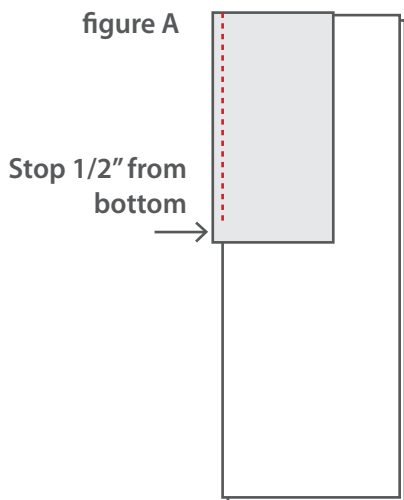

Step 3: SEW OUTER BAG.

Note: Seam allowance from this point forward will be 1/2". Sew one coated cotton side piece to the canvas right sides together, stopping 1/2" from the bottom to leave space for the seam allowance at the bottom. See figure A. Repeat on the other side as shown in figure B. Sew remaining sides of the coated cotton side pieces to the other side of the main piece, forming the bag shape, as shown in fig. C. Again, stop and backstitch 1/2" from the bottom. Then flatten the bottom and sew from the end of your stitching on one side to the end of the stitching on the other sides, as shown in fig. D. Next, flatten the long sides of the bottom and sew along the folded fabric 1/2" from the edge, from corner to corner as shown in fig. E.

Step 4: SEW LINING.

Repeat the previous step with the coated cotton pieces to form the lining of the bag. But this time, leave a 6" opening along one of the sides to turn the bag right sides out in a later step. Be sure to backstitch around the opening.

Step 5: ADD MAGNETIC SNAP.

Center one side of the magnetic snap about 1 1/2" and centered on the lining of the bag. Mark where the holes should go and snip the opening carefully with a small pair of sharp scissors. Insert the backing of the snap and bend the prongs down. Repeat for the other side.

Step 6: SEW LINING TO OUTER BAG.

Turn the lining *right sides out* and insert it into the main bag, which should still be *wrong sides out*. Now the right sides will be facing one another. Pin around the top, positioning the straps in place about 2" from the corner seams, as shown below in figure F. The straps should be inside the bag between the layers, with the raw edges coming out the top. Be sure that the straps are not twisted. Sew around the top.

Step 7: TURN RIGHT SIDES OUT AND FINISH.

Gently pull the bag right sides out through the opening in the side of the lining. Pin the opening closed and topstitch.