

LP-PAN

Software Defined
IQ Panadapter



Operating & Assembly Manual

April 2009
TelePost Incorporated
Rev. D7

Table of Contents

Introduction	3
Parts List.....	4
Assembly	7
Installation & Setup	12
Operation	19
Using LP-Pan with CW Skimmer	23
Circuit Description	24
Schematic	25
Troubleshooting & Support	26
Specifications and Warranty	27
Appendix A	28

Copyright and Trademark Disclosures

LP-PAN is a trademark of TelePost Inc. Windows® is a registered trademark of Microsoft Corporation. Material in this document copyrighted ©2007,8 TelePost Inc. All rights reserved. LP-Bridge copyrighted ©2007,8 TelePost Inc. All rights reserved. PowerSDR™ is an open source application for use with IQ based software defined radios, and is a trademark of FlexRadio Systems.

Introduction

Read Carefully Before Continuing.

Assembling LP-PAN is a straightforward job, and you should have no trouble if you follow the instructions. Take special note of the connection diagram, and become familiar with the basics of how the various components fit together in the system.

Installing and configuring PowerSDR can be tricky. It is a complex program, and requires quite a few steps to get set up properly. Lots of Flex Radio users have done this though, so don't let it scare you. Pay special attention to the sound card setup. If you're using the E-MU 0202 USB sound card, you will probably want to visit the Creative Labs website for the latest driver. The E-MU driver does not support Windows 2000, but works with XP and VISTA, 32 and 64. There is some question about whether there may be a problem in XP SP3 though. I believe SP3 post dates the latest E-MU driver, though.

If you get in trouble, help is an email away. There are plenty of helpful users on the LP-PAN User Group, <http://groups.yahoo.com/group/LP-PAN/>, or you can send an email to larry@telepostinc.com. Phone support is also available at 734-455-3716.

LP-PAN Features

LP-PAN is a software defined IQ direct conversion panadapter. Here is a list of current features...

- * Up to 192 kHz display on PC, sound card dependent
- * Switching quadrature detector for high dynamic range
- * Strong buffer amp with low NF and very high LO isolation.
- * Excellent THD and IMD performance
- * Ground isolated inputs / outputs with mil spec audio xfmr's
- * Low output Z, balanced or unbalanced.
- * Fully balanced architecture with balanced and unbalanced outputs
- * Jumperable ground lift on RF input and audio outputs
- * Works with many SDR programs.
- * Adjustable gain to interface almost any sound card
- * Point and click frequency control with PowerSDR / IF Stage and LP-Bridge or HRD . In addition, LP-Bridge allows sharing of K3 / LP-PAN with almost any logger, and even programs such as CW-Skimmer
- * Powder coated aluminum enclosure with silk screened graphics.
- * Hardware or software mute
- * Available for IF frequencies of...
 - 8.215 MHz (Elecraft K3)
 - 8.83 MHz (Kenwood)
 - 9.0 MHz (Orion)
 - 4.915 MHz (Elecraft K2)
 - 10.7 MHz (IC-R8500/9500, others)

Note: Specifications dependent on sound card, and subject to change. Cited values were taken with an E-MU 0202 USB sound card. All measurements also apply to E-MU 1212m and 1616m PCI cards, and M-Audio Firewire Audiophile 2496 card (limited only by 96 kHz display width). For latest sound card info, see www.telepostinc.com/soundcards.html

Parts List - Subject to change without notice. Pictures shown at end of parts list.

Pre-installed SMT parts

Quantity	Designation	Description
5	C5,11,18, 31, 39	0.01uF
2	C4, 6	0.1uF
1	C7	1uF
1	C9	0.22uF
1	L4	10uH
1	L8	12uH
0	L9,10	0.11uH (alternate to L11,12)
2	L11, 12	0.11uH
2	R1, 3	1K 1%
1	R4	4.7K 1%
1	R5	200 ohm 1%
2	R6, 7	499 ohm 1%
2	R8, 28	49.9 ohm 1%
1	T3	Toroid XFMR 1:1
1	T4	Toroid XFMR 4:1
1	U11	ADCMP600 Comparator
1	U2	74HC/HCT163 Counter
2	U4,7	LT6231 Low Noise Op-Amp
1	U5	AD8007 Transconductance Amplifier
1	U8	SN74CBT3253D 4x2 Analog Multiplexer

Through-Hole Parts

Quantity	Designation	Value
1	C1	33pF ceramic disc (marked 33) Fig. 3
6	C2,3,8,20,33,42	0.1uF monolithic (marked 104) Fig. 1
--	C10	Not used
1	C12	18pF ceramic disc (marked 18) Fig. 3 K2: 81pF (marked 81)
1	C13	10pF ceramic disc (marked 10) Fig. 3 K2: 68pF (marked 68)
8	C14,16,22,24,27,29, 32,37	0.01uF ceramic disc (marked 103) Fig. 3
5	C15,17,23,25,38	1uF (25V electrolytic) Fig. 2
1	C19	100uF (25V electrolytic) Fig. 28
2	C21,28	Kenwood: 220pF(221), 10.7MHz: 0.001uF (102), K3/K2/Orion: None
1	C26	10uF (25V electrolytic) Fig. 2
1	C30	47pF SM (47) Fig. 4 , 10.7MHz: 22pF(22)
2	C34,35	4-20pF trimmer cap Fig. 19
1	C36	56pF ceramic disc (marked 56) Fig. 3
1	C40	0.001uF ceramic disc (102) Fig. 3
2	C41,43	3300pF ceramic disc (332) Fig. 3 Kenwood/Orion: 2700pF(272), K2: 0.01uF(103) 10.7MHz: 0.001uF(102),
1	D1	Green LED Fig. 9
1	D2	1N4148 Fig. 18
1	J1	Insulated BNC connector Fig. 17
2	J2,13	3.5mm Stereo Audio Jack Fig. 20
1	J3	RCA Jack Fig. 21
1	J11	2.5mm DC Power Connector Fig. 7
4		2-pin Jumper Fig. 11
3	JP1-3	2-pin Header Fig. 11
1	JP4	3-pin Header Fig. 11

Parts List – Cont'd

Quantity	designation	Value
6	L1,2,3,5,6,7	1mH RF Choke (br-bk-rd) Fig. 5
1	Q1	MPS5179 transistor Fig. 10
2	R2,31	10 ohm 1/8W res. (br-blk-bk) Fig. 12
4	R9,17,18,34	1K 5% 1/8W res. (br-blk-rd) Fig. 12
4	R10,14,15,16	1.1K 1% 1/8W res. (br-br-bk-br-br) Fig. 12
1	R11	1.5K 5% res. (br-grn-rd) Fig. 12
3	R12,21,22	2K 5% 1/8W res. (rd-bk-rd) Fig. 12
4	R13,19,20,27	22 ohm 1% 1/8W res. (rd-rd-bk-gld-br) Fig. 12
1	R23	1K Pot Fig. 22
2	R24, 35	10K 5% 1/8W res. (br-bk-or) Fig. 12
1	R25	27K 5% 1/8W res. (rd-viol-or) Fig. 12 (1% may be supplied as alternate)
1	R26	470 ohm 5% 1/8W res. (yel-viol-br) Fig. 12
1	R29	200 ohm Pot Fig. 23
1	SW11	4PDT Pushbutton Switch & Keycap Fig. 6
2	T1,2	Audio Output Xfmr, 600 ohm Fig. 25
1	U1	78L05 5V Regulator Fig. 10
1	Y1	32.836MHz Crystal Fig. 24 (K2: 19.68MHz, Kenwood: 35.35MHz, TenTec: 36.000MHz, 10.7MHz: 14.31818MHz)
1		PCB Fig. 26
1		Enclosure Fig. 27
1		Power Cord Fig. 8
6		¼" Black Sheet metal screw Fig. 14
8		3/16" Black machine screw Fig. 15
4		1/4" standoff Fig. 13
4		Rubber feet Fig. 16

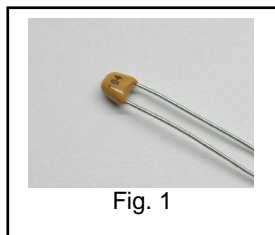

Fig. 1

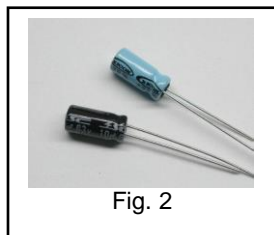

Fig. 2

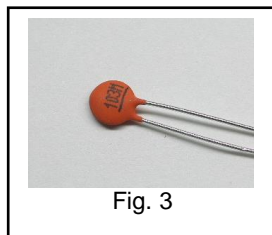

Fig. 3

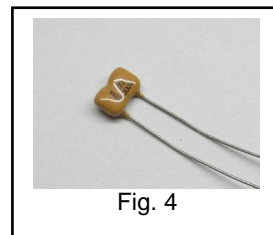

Fig. 4

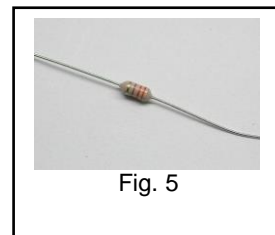

Fig. 5

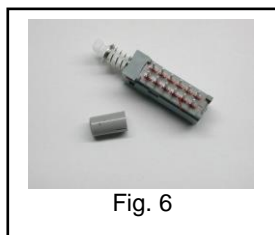

Fig. 6

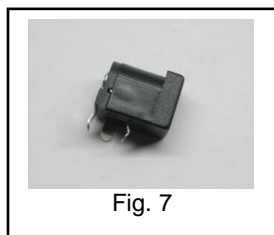

Fig. 7



Fig. 8

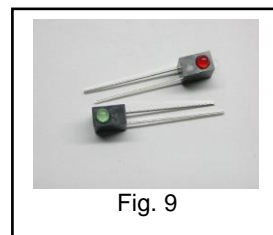

Fig. 9

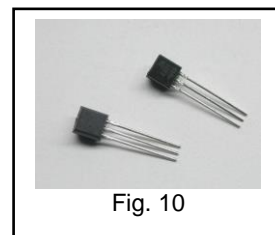

Fig. 10

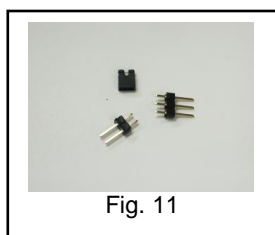

Fig. 11

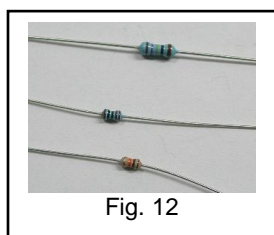

Fig. 12

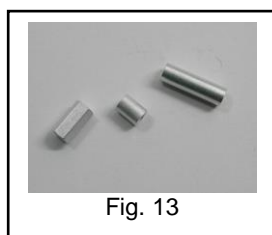

Fig. 13

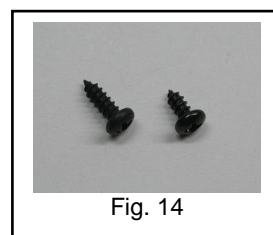

Fig. 14

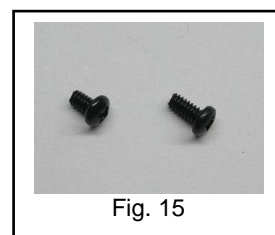
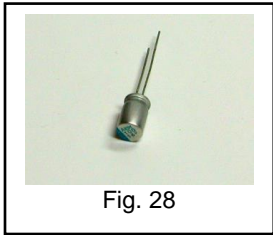
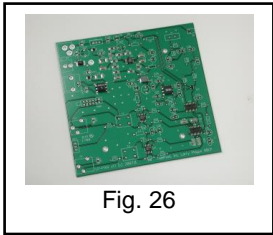
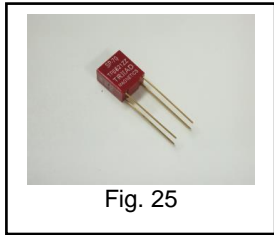
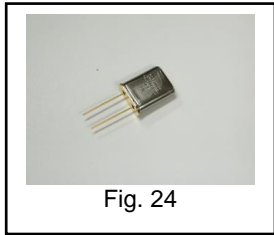
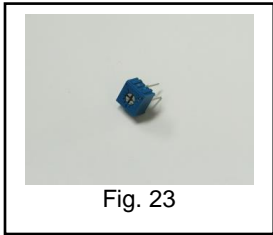
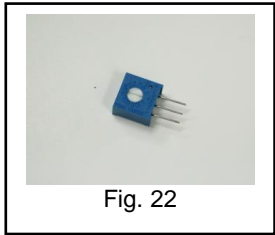
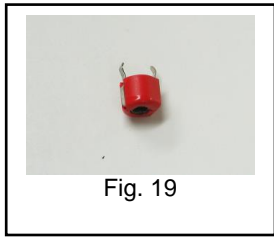
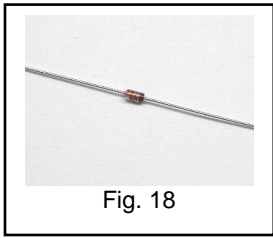
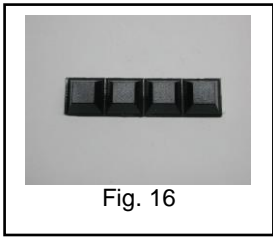

Fig. 15

Parts List – Cont'd



Assembly

Important warnings – read this before starting assembly

You should visually inspect all the solder pads/traces with a magnifier for any etching problems. This is done before shipping, but I recommend the builder do a second inspection as well. We do 100% continuity checks of all pads before shipment using computer controlled flying probes based on PCB netlist coordinates.

All of the SMT components are pre-installed on the main board for your convenience. SMT parts are supplied wherever necessary for performance or availability reasons. **CAUTION: Be very careful handling this board to avoid damage to the installed parts. Anti-static measures are highly recommended, such as use of an anti-static mat, grounded soldering iron and wrist band.**

You may wish to clean the flux from the board after assembly, although it is not necessary with most modern solders. A toothbrush and alcohol are good for this. Only use rosin core solder. Use of acid core solder voids the warranty. Lead-free solder is OK, and the boards are RoHS compliant, but it will be more difficult to remove parts without damaging the board should you have to.

Overview

Below is the component placement diagram for the main PCB. These markings match the silk-screening on the PCB, but are repeated here for clarity. You can also cross out the parts on this graphic as they are installed. You should check all parts before starting to allow you to start the process of obtaining replacement parts as soon as possible if needed. It is also a good idea to sort the parts in advance... egg cartons are handy for this (passive parts only). Many craft stores, like Michael's, also have nice plastic cases with dividers at low prices. If there is any doubt about component values, especially with the 1% resistors which can use strange markings, check them with your DMM.

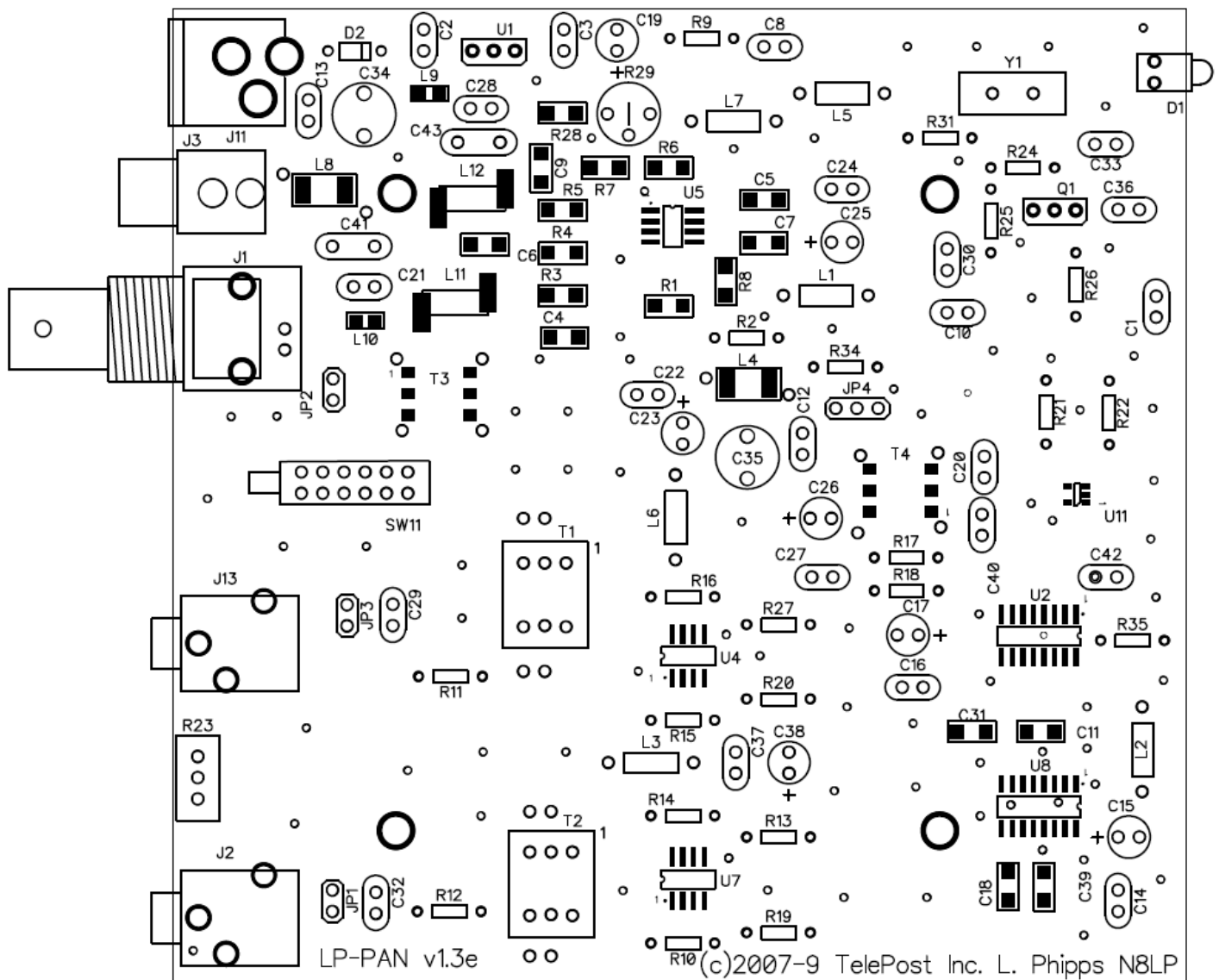

Assembly Cont'd

Pre-assembly overview.

When assembly starts on page 9, it will roughly follow this order...

- Installation of resistors
- Installation of ceramic disc capacitors
- Installation of miscellaneous small parts
- Installation of miscellaneous large parts and connectors
- Installation of chokes

The idea is be able to lay the board flat as much as possible during construction, with lowest parts being installed first. The chokes are the lone exemption... they are installed last so as to make sure each circuit is drawing the right amount of current before continuing. This is done by monitoring total current draw of LP-PAN while adding the chokes one by one.

You will need the following tools to complete assembly...

- Adjustable soldering iron – 800 degrees maximum
- 60/40 alloy solder... .020" (0.51mm) diameter recommended for thermal pads
- Needle-nose pliers
- Wire cutters
- Small Philips head screwdriver
- Digital Multimeter

NOTE: The LP-PAN is an intermediate level kit. I would peg the assembly time at about 2-3 hours, plus some reading through the manual in advance, and some time for calibration afterward. Take your time, and double-check your work, and you should have no problem. All critical parts are pre-installed.

Assembly Cont'd

Step-by-step assembly instructions.

Below is a picture of the assembled PCB. The SMT parts come pre-installed. The component layout diagram on page 7 provides another aid to component identification. Units after #309 will be ever so slightly different... mainly in the area of C41 & C43.

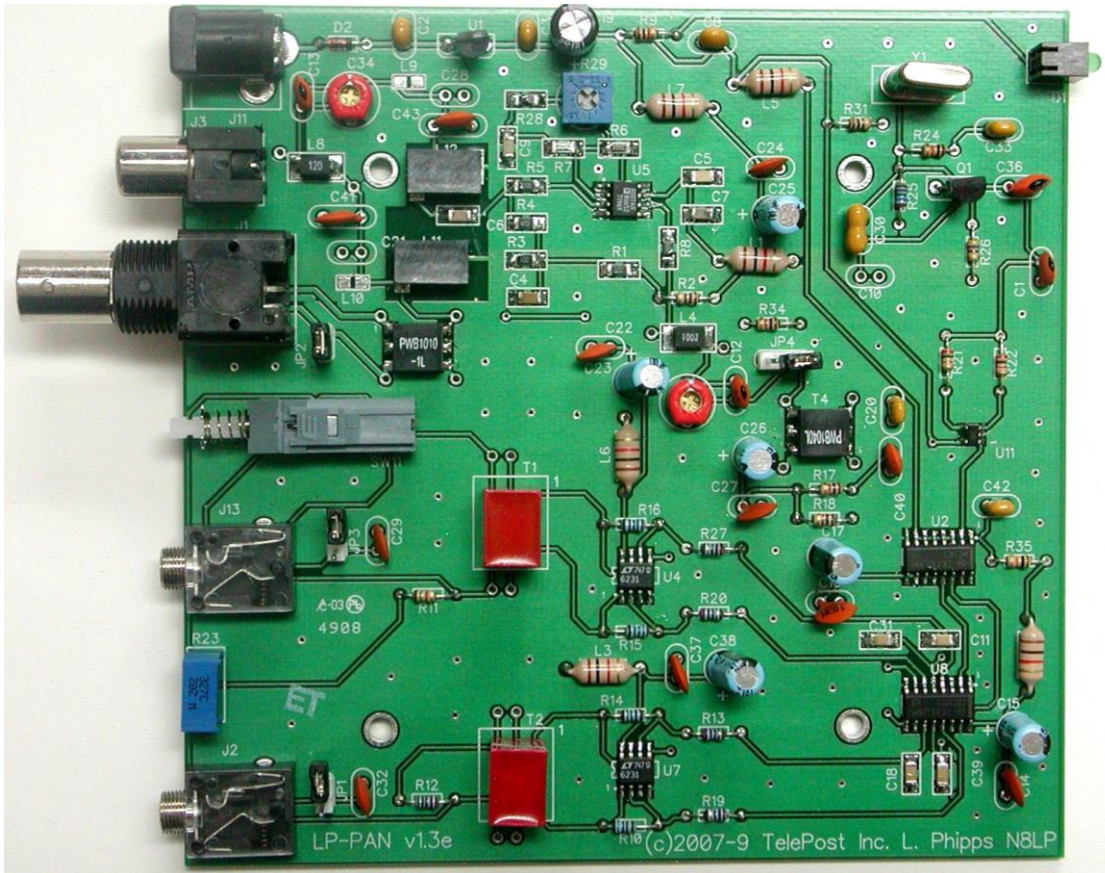

It is recommended that you print at least this portion of the manual to allow for easy reference while building, and to allow you to check off the steps as you complete them. Make sure your work area is static-free to avoid damage to the pre-installed SMT parts. It is also advisable to wear an anti-static wrist band and grounded soldering iron. Refer to the parts placement graphic on page 7 or the above picture for questions regarding parts placement.

- Install resistors. Solder and clip leads after about six parts are installed to minimize clutter. If you are unsure of the colors used by some of the manufacturers for the color code, especially the 1% parts, measure the value with a DMM. Occasionally, parts listed as 5% will be supplied as 1% due to availability when ordering. Double check with DMM.
- R2,31 10 ohm 1/8W res. (br-blk-bk)
- R9,17,18,34 1K 5% 1/8W res. (br-blk-rd)
- R10,14,15,16 1.1K 1% 1/8W res. (br-br-blk-br-br)
- R11 1.5K 5% res. (br-grn-rd)
- R12 2K 5% 1/8W res. (rd-rd-blk-br-br) or 2.2K 1% (rd-r-bk-br-br)
- R13,19,20,27 22 ohm 1% 1/8W res. (rd-rd-bk-gld-br)
- R21,22 2K 5% 1/8W res. (rd-bk-rd)
- R24,35 10K 5% 1/8W res. (br-bk-or)
- R25 27K 5% 1/8W res. (rd-viol-or)
- R26 470 ohm 5% 1/8W res. (yel-viol-br)

- Install the two audio jacks next. Solder the center lead first, so that you can adjust the jacks to be parallel with the board edge before soldering the remaining pins.
- Install D2. Follow polarity markings on PCB.

Assembly Cont'd

- Install all 0.1 uF caps (marked 104).
 - C2
 - C3
 - C8
 - C20
 - C33
 - C42
- Install all .01 uF caps (marked 103).
 - C14
 - C16
 - C22
 - C24
 - C27
 - C29
 - C32
 - C37
- Install remaining ceramic disc and SM caps, and the two trimmer caps.
 - C1 33pF ceramic disc (marked 33)
 - C12 18pF ceramic disc (marked 18) –For K2: 81pF (marked 81)
 - C13 10pF ceramic disc (marked 15) – For K2: 68pF (marked 68)
 - C30 47pF SM (marked 47)
 - C36 56pF ceramic disc (marked 56)
 - C40 0.001uF ceramic disc (102)
 - C34, 35 4-20pF trimmer cap
 - C21, 28 Not used on K3 or Orion – For Kenwood: 220pF (marked 221), For 10.7: 0.001uF (marked 102)
 - C41, 43 3300pF ceramic disc (marked 332) – For Kenwood/Orion: 2700pF (marked 272), For K2: 0.01uF, For 10.7: 0.001uF (marked 102)
- Install D1 (LED)
- Install Q1. Keep leads short.
- Install U1. Keep leads short.
- Install R29 (pot).
- Install SW11
- Install J3. You will need to clip off the two plastic tabs on the bottom of the connector off before installing. Latch the rear pin first for strength, then solder the front pin.
- Install J11
- Install the three 2-pin and one 3-pin headers. Install a shorting jumper between pins at JP2. Install a jumper on the ground pin only on JP1 & JP3. Install a jumper between pins 2 & 3 of JP4 (the two toward the front of the board).
- Install T1 and T2. Orient pin 1 near the silk-screened “1” marking, as shown.
- Install R23 (pot)
- Install crystal, Y1
- Install the electrolytics, taking care with polarity. The “+” lead is the longer one, “-“ lead is marked with a black or white stripe, or blue semi-circle.
 - C15, 17, 23, 25, 38 1uF (25V)
 - C19 100uF (25V)
 - C26 10uF (25V)
- Install J1

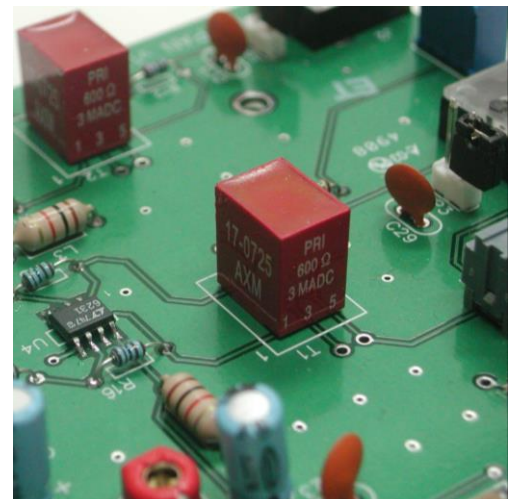

Assembly Cont'd

- ❑ Make sure that your bench is clean and the PCB is not sitting on any cut off component leads. Connect supplied power cable to a supply of 11-16 VDC. The dashed white lead on the supplied power cable is the + lead (center pin). The green LED should light. Using your DMM, check for 5.0 VDC (+/- 0.25V) at pin 3 of U1 (the pin connected to C3). Monitor total current draw of LP-PAN using the DMM or current meter on a power supply. Current draw should be 28mA. Power down.
- ❑ Install the 1mH ceramic chokes (br-blk-red) one at a time, and check LP-PAN current draw as each one is added to verify no unexpectedly high changes to total current draw. Expected total current draw is shown after each choke. If your values vary significantly from these, check your work in the circuit affected by the most recently added choke. Refer to schematic.
- ❑ L5 29mA
- ❑ L7 31mA
- ❑ L1 39mA
- ❑ L2 41mA
- ❑ L3 47mA
- ❑ L6 53mA
- ❑ Attach the four rubber feet to the bottom of the enclosure.
- ❑ Install the PCB in enclosure using 3/16" black screws and 1/4" standoffs. Loosely install the standoffs on the bottom, and then slide the board into place, rear first. Attach the screws from the top while aligning the holes on the rear panel, then tighten the screws underneath.
- ❑ Install keycap on SW11. The enclosure top will be installed after calibration.

Connections...



Power: 11-16 VDC, center pin +, 2.5mm. The lead with the white stripe on the supplied cable is +. Power can be derived from a wall wart, accessory power supply, RigRunner type manifold or the accessory power jack on the K3. In general, a supply with a linear regulator will provide lower overall noise floor and fewer visible spurs on the panadapter display than a switched regulator will.

Mute: Gnd to mute. 5VDC. This will not be used in most installations, a software mute is provided by LP-Bridge / PowerSDR. See PowerSDR Operation section of this manual for details.

IF Input: From rig. 8.215 MHz for Elecraft K3, 8.83 MHz fo Kenwood, 9.0 MHz for Orion (II).

Bal/Unbal: Out for balanced, In for unbalanced

I/Q Outputs: To sound card inputs

Match: Used to fine tune load balance between channels (Name changed to "Match" starting with serial #101 to better describe its function).

Installation and Setup

System Overview

Before starting, it helps to read this section in order to understand the basics of how the K3, LP-PAN, PowerSDR, Sound Card and LP-Bridge (or HRD) work together. In general, the duties of each part of the system are as follows:

LP-PAN – Provides audio baseband IQ signals for application to a high quality sound card, which becomes the interface to PowerSDR. The signals are derived from the broadband IF output of the K3.

PowerSDR – Provides decoding and processing of the audio signals. In addition to providing a panadapter or waterfall display, PowerSDR is actually a high quality receiver AND sub-receiver. It rivals the K3 in many ways, and adds some features not available on the K3.

LP-Bridge - Provides a serial interface to the K3, and computer links to PowerSDR. This allows linking of the K3 to PowerSDR for Frequency, Mode, Preamp setting, Mute, IF Offset and other functions. A serial cable is required between the K3 and the PC to enable the communication link. Without this link, PowerSDR will act as a panadapter with “relative” frequency display, for instance, +/- 96 kHz from a center “zero” frequency which represents the center of the IF.

Sound Card – The link between LP-PAN and PowerSDR. A high quality sound card is preferred. These are available for about \$80-\$140. See the sound card page on the TelePost website for latest recommendations. <http://www.telepostinc.com/soundcards.html>

Rig: K3 shown

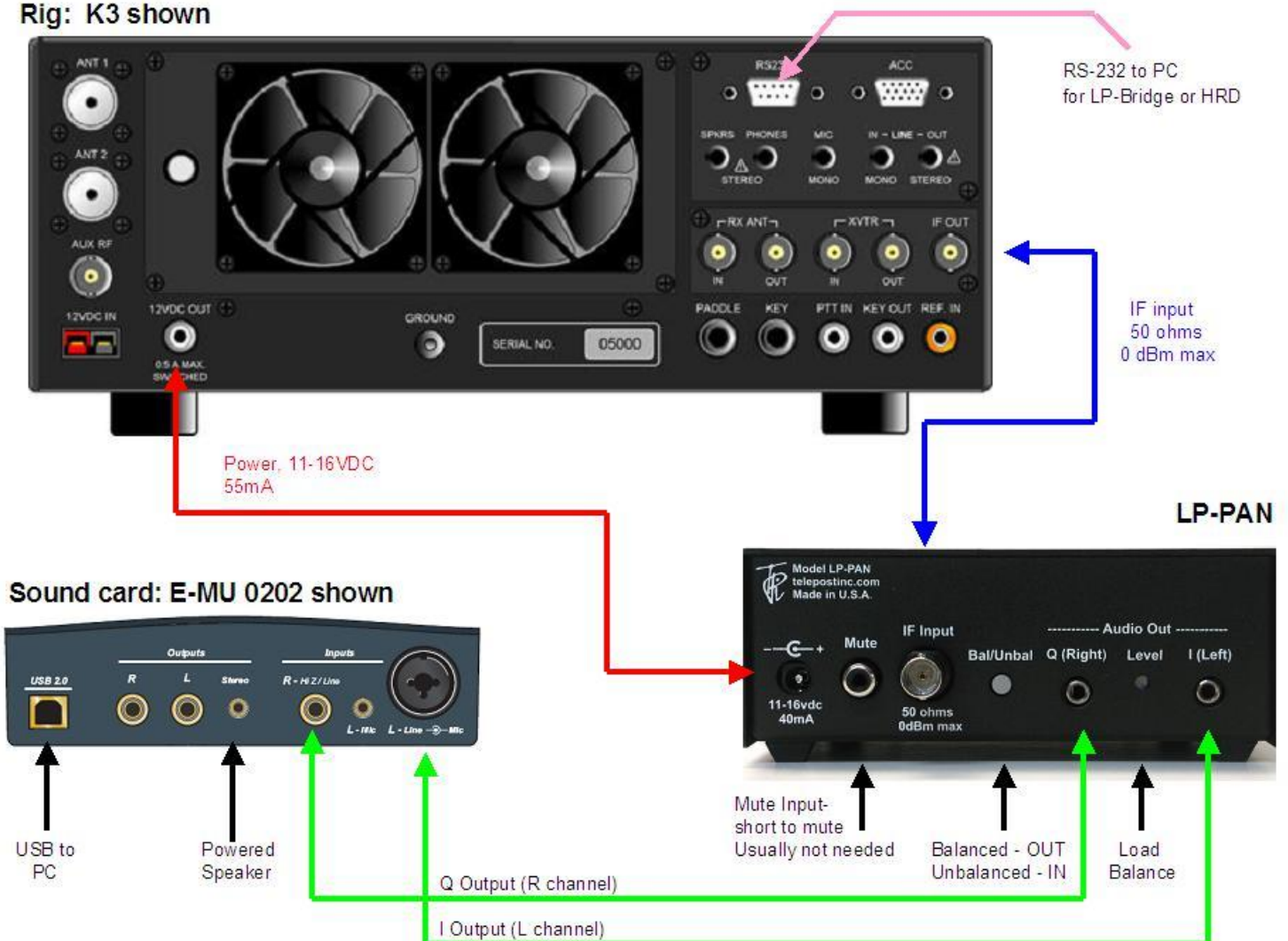

Above is a diagram showing typical interconnection of the LP-PAN system.

Installation and Setup cont'd.

Initial LP-PAN Settings

Set JP1 & JP3 to open, JP2 to shorted, and JP4 to pins 2 & 3 (two closest to front of the board), as shown in the photo on page 9. Set gain pot R29 to the middle of its range, and the Match pot on the rear panel level pot to full clockwise.

Connecting the Sound Card

The connection to the sound card will be largely determined by the sound card inputs. Here are some common possibilities...

Sound card with a pair of unbalanced mono inputs (usable with E-MU 0202, 1616m, M-Audio Audiophile Firewire and 2496).

Set Bal/Unbal switch to Unbalanced (IN). Use a pair of mono cables with the appropriate connectors on the sound card end. In the case of the E-MU 0202, these will be 1/4" phone plugs. Note: The left channel input on the E-MU uses a "funny" combo connector, but accepts a 1/4" mono phone plug. DO NOT use a stereo plug here, as it can get hung up on the ridges around the middle ring.

Sound card with a pair of balanced mono inputs (usable with Delta44, E-MU 1212m, 1616m).

Set Bal/Unbal switch to Bal (OUT). Use a pair of stereo cables with 1/8" male on LP-PAN end and 1/4" male connectors on the sound card end.

Sound card with a single stereo input (typical of inexpensive SoundBlaster type cards).

Set Bal/Unbal switch to Unbal (IN). Use a pair of 1/8" mono cables on the LP-PAN end, and a Y connector or adapter to combine them into one stereo connector at the sound card end. Generally speaking, a red connector indicates right channel and white indicates left channel, if marked. If using a commercial Y cable, make sure it is one stereo to two mono connectors, and not just wired in parallel.

In most cases, your monitor speaker will connect to the stereo output jack or headphone jack of the sound card or PC, depending on setup. You may need a Y adapter for some cards to combine two mono outputs into a stereo monitor output. If you plan to use the sub-receiver in PowerSDR, stereo speakers are very useful as the two receivers are routed to different channels.

Refer to www.telepostinc.com/souncards.html for specific details about driver settings, pre-configured mixer config files and latest sound card info. Links to detailed installation instructions for each of the recommended sound cards are provided there.

Connecting the K3 to LP-PAN

Connect the RF input of LP-PAN to the IF output of the K3 using a short, high quality 50 ohm jumper cable with male BNCs on each end.

The Mute connector can be left unused for now. For a complete discussion of the mute function, see the Operation section of the manual.

LP-PAN can be powered from a RigRunner type power manifold, a wall wart (11-16VDC at 50mA) or the Accessory DC jack on the back of the K3. The wire on the supplied power cable with the white line is positive voltage (center pin of DC connector).

Initial Software Installation

Download PowerSDR/IF Stage v0.92 from Scott McClements, WU2X's web site, <http://www.wu2x.com/sdr.html#powersdr> Follow the instructions on his web page for the basic software installation. Setup and preferences will be discussed on the next page of this manual.

Download LP-Bridge from the TelePost web site at <http://www.telepostinc.com/LPB.html> Install in the default directory, following the instructions on the LP-Bridge web page. Refer back here for detailed setup and configuration information.

Note: Both programs are beta versions, and as such are not complete, but should be fully functional at their current level of development. You should be logged in as Administrator when installing these programs, or using another account with admin privileges.

K3 Firmware: You must be using MCU version 2.13 or later for full compatibility with LP-Bridge. This version added an IF frequency offset parameter to the CAT protocol which allows automatic frequency correction with LP-Bridge. This feature is not supported in HRD.

Installation and Setup cont'd

Special note for European users:

In Windows control panel, open the "Regional and Language Options" panel, select Regional Options, and then Customize. Select "." (period) for Decimal Point, Select "," (comma) for Digit Grouping Symbol. This is normally reversed in most of Europe. The version of PowerSDR that we based our sub-version on does not understand European numbering. I think the latest version does, and we will update to that version this Fall.

If you have a problem with the numerical displays, and have run PowerSDR with normal European numbering already, you will have to uninstall PowerSDR, including the WU2X folder, because the PowerSDR.mdx can be corrupted. Reinstall after changing the Regional Options and you should be OK.

Software Installation:

The following assumes that you will be using PowerSDR/IF Stage and LP-Bridge...

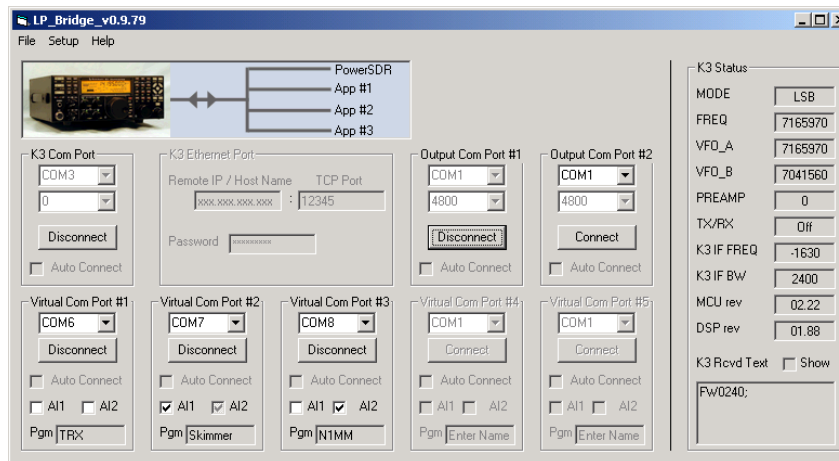

Start LP-Bridge. In the section labeled K3 Com Port, select the port that your K3 is connected to. Make sure the K3 is set for 38,400 baud. **Warning: If you are using a USB to serial adapter, it is recommended that it use an FTDI chipset. The KUSB adapter sold by Elecraft does not, and will likely cause problems.** Click the Connect button. The button will change to Disconnect unless there's a problem. You should see data in the K3 Rcvd Text window in the bottom right of the display, and the K3 Status fields.

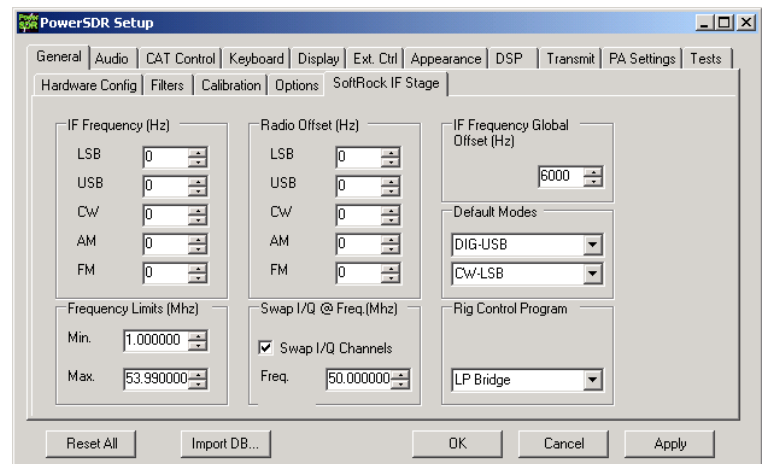
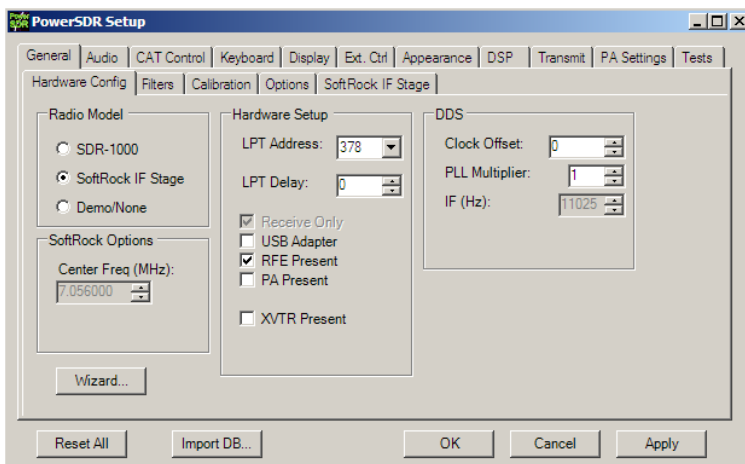

Start PowerSDR. After it starts and initializes the FFTs, you may see an error message about HRD not running. Close the message and select File>Setup and the General tab>Hardware Config sub tab. **Select SoftRock IF Stage in the Radio Model section. Make sure "RFE Present" box is checked. Leave all other settings as they are. Click on the Softrock IF Stage sub tab, and set all the options to exactly match the above right picture. These will all stay this way except the Global Offset value, which will be fine tuned later.**

Installation and Setup cont'd

Go to the Setup>Audio tab>Sound Card sub tab, pictured below. Set the sound card to "Unsupported Card". Select the correct driver for your sound card. For most modern professional sound cards, this will be ASIO, but if the card is older you may have to use WDM. Select your sound card Input and Output, and select None for Mixer. Set the sample rate to the maximum supported by your card, set Buffer Size to 2048 or 4096 and click Apply. Other settings can be ignored, although I found with my E-MU 0202 card that it wouldn't start reliably UNLESS I selected Expert Mode and set Latency to 2ms. Other cards may require a higher setting, up to about 25 ms.

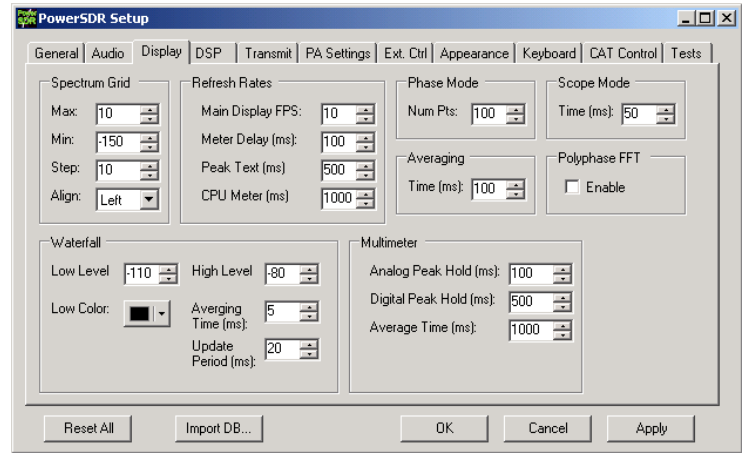
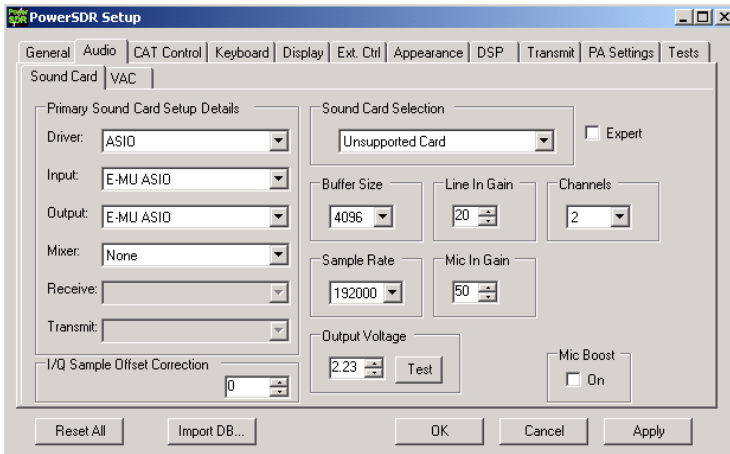

In the Display tab, the vertical scale should be set for a displayed range of -10 to -130 dBm for now (entered range of +10 to -140dBm). I set Averaging to 200ms, but you may find a different value better. This determines the averaging when the AVG button is pressed in the main PowerSDR screen, and trades off lower displayed noise for lag when updating the display. All other settings can be left as they are for now. Click Apply and close the Setup window.

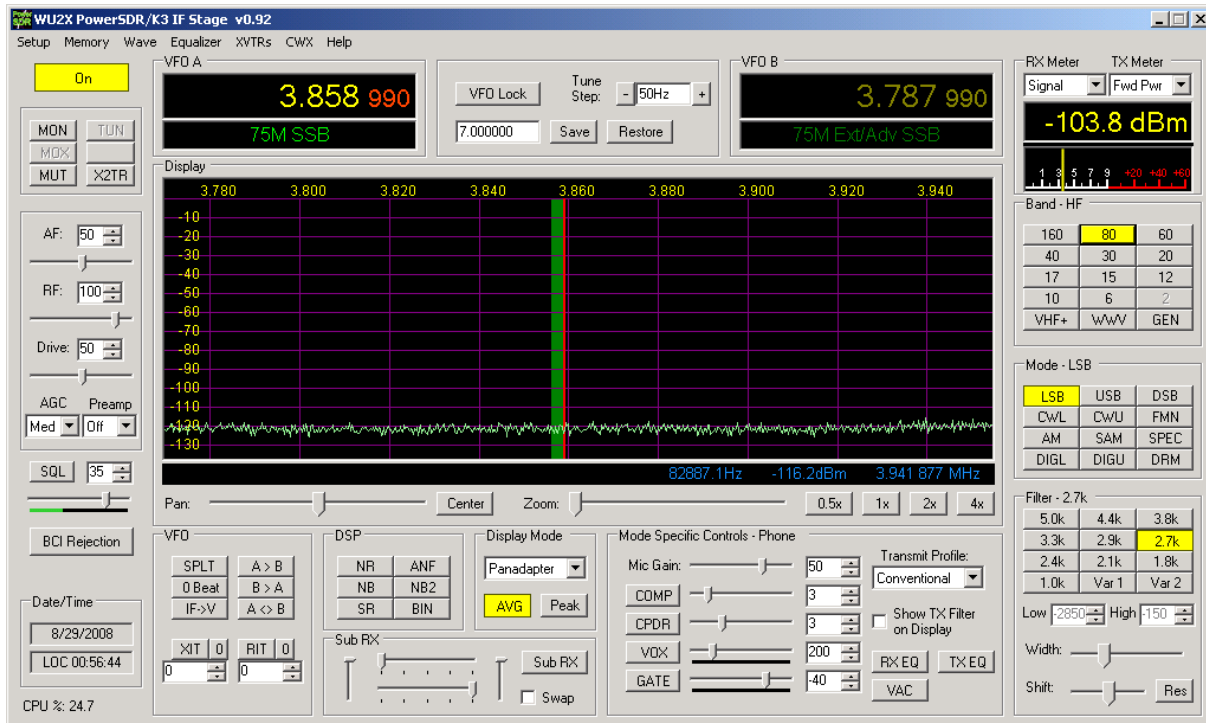

On the main PowerSDR screen, click on the Standby/On button in the upper left and you should hear LP-PAN on your sound card monitor speaker. Display Mode should be set for "panadapter", and AVG turned on now. To display maximum bandwidth, the PAN slider should be centered, and the Zoom slider should be all the way to the left. The frequency display should roughly match the VFOA frequency of the K3. The noise floor with no antenna connected to the K3, K3 preamp OFF, PowerSDR preamp setting set to OFF, should be between -110 and -120 dBm, and should be flat with no signals, as shown above. We will calibrate the levels later, but the noise floor should be roughly in the range shown. It depends somewhat on whether you have the K3 buffer mod installed. More on this in the Calibration section below.

Installation and Setup cont'd

If you are using a E-MU 0202 USB card, the input gain controls should be set to between 10 and 12 o'clock to obtain this noise floor. The two pots should be set as close to exactly the same as you can or else initial image rejection will be poor. If your card uses a software level control, it should be set near maximum with line input selected, and should indicate the noise floor mentioned above. Some professional sound cards will have fixed inputs.

If you are seeing any signals (vertical blips), then there is something in your cabling / ground lift settings that is not right. Small blips, say 10dB above the noise floor could be the result of radiation from your monitor or USB cabling, and rearranging things might help. Spurious signals and elevated noise levels can also be due to a noisy switching power supply in your shack. I had tiny blips on an older PC with a 21" CRT monitor, and had to move the sound card away from the monitor. On my laptop and other PC with LCD monitor I had no problem. Small blips should not be a problem in practice, especially with AVG off.

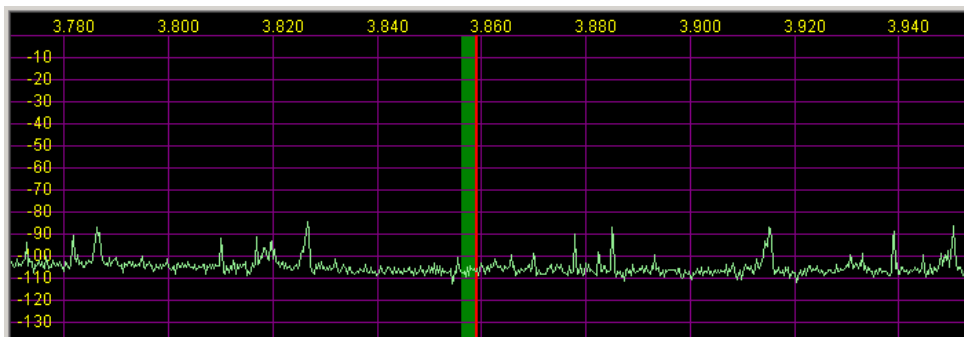

Connect an antenna, and the noise floor should jump up a bit, depending on band, and you should see lots of signals if the band is open, as above. I recommend 40m as a good starting point, since there are always signals, and at night you can see some very strong ones. If all is OK up to this point, continue to the next section.

Calibration

There are only a few hardware adjustments that need to be made in LP-PAN... filter peaking, overall gain setting and load balance. **Note: Filter peaking is only required for kit versions.** All adjustments are made while monitoring the PowerSDR display. Load balance is done in conjunction with the Image Rejection controls in PowerSDR.

Filter adjustment - To adjust the LP-PAN filter, tune to a strong carrier, S9 or better, and peak C35 for maximum strength. If you don't have an insulated tuning tool, a small screwdriver can be used, but you will have to remove the screwdriver between adjustments to see the effect of the adjustment. After C35 is peaked, adjust C34 for maximum signal.

Gain adjustment - To set the gain display accuracy requires a signal source with known output level. This can come from a calibrated signal generator, or something as simple as the Elecraft XG1 or XG2 test oscillators, which have an output of about -73dBm ($50\mu\text{V}/\text{S9}$). Set the K3 preamp and attenuator OFF, and the Preamp setting in PowerSDR to OFF. Turn AVG on in PowerSDR. Connect your generator to the RX ANT input of the K3, and select RX ANT. Adjust your sound card inputs for a displayed level of -73dBm . If you run out of range on your sound card input, you can adjust R29 on LP-PAN as well. The pot has about 8dB range. If you have an adjustable generator, you can check sound card gain for proper dynamic range limits. You can decide the range that is ideal for you, but as a frame of reference I have mine set to clip at -8dBm input. In my case, I have the K3 buffer mod installed in my K3. This adds about 10dB gain ahead of LP-PAN. If you don't have the mod installed, the clip point and noise floor will be about 10dB higher. Details of the buffer mod can be found in the Files section of the LP-PAN Yahoo Group site at <http://groups.yahoo.com/group/LP-PAN/files>.

Installation and Setup cont'd

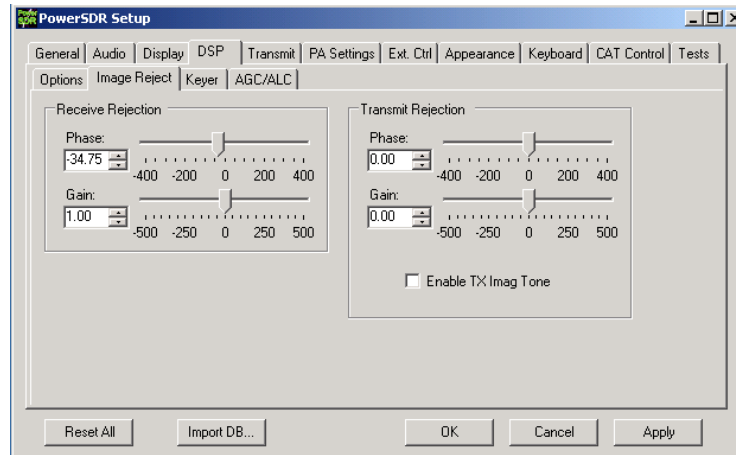

Image Rejection Adjustment - At this point, strong signals will display an image on the opposite sideband, with 2nd harmonics at about 70dB down until clipping is imminent. Image rejection is adjusted in the DSP tab in PowerSDR Setup, under the "Image Reject" sub tab, shown above. If your sound card has hardware input pots, make sure they are set for the same level. If your sound card has software level controls, set both channels for the same level. Most software mixers have a way of adjusting the levels together. Also, if there is a balance control, make sure it is centered, or if there are pan controls, make sure the left channel is panned all the way left and the right panned all the way right. You can set a quick image null by placing the signal midway between the left edge of the display and the center. The image will appear midway between the center and right edge. AVG should be OFF for these adjustments. Adjust the phase and gain sliders for minimum amplitude of the image. The sliders provide a rough adjustment. You must use the Up/Dn arrows to fine tune the null. The adjustment is quite critical to get maximum null depth. The correct setting should be within approx. +/-100.00 for Phase, and +/- 50.00 for gain. **NOTE: If you have an E-MU 0202 sound card, you might want to try this procedure: Set Gain and Phase sliders for 0.00, set E-MU left channel pot at 11 O'clock, adjust right channel pot for a rough image null. Then use the sliders/arrows to fine tune. The extra step may be needed in case the physical pot positions on the E-MU are a little out of alignment. Any future adjustment in the left pot setting will require a readjustment of the right pot and readjustment of the sliders/arrows.**

This will not be the best setting for overall broadband image rejection, however. There is an iterative process for improving the broadband image rejection, which essentially finds a median setting which will be close for all frequencies, but not perfect at any one frequency.

The procedure is outlined below.

- 1) Tune in a strong signal (-50dBm or higher) from a signal generator or nearby transmitter.
- 2) Tune the K3 to put the image midway between the center of the display and the left end of the display.
- 3) Set the Image Reject Phase and Gain adjustments for minimum image response. Log the values.
- 4) Retune the K3 to put the image signal midway between the center and the right end of the display. Adjust for minimum response and log the values.
- 5) Set the Image Reject controls for the midpoint of the logged settings.
- 6) Adjust the Match control on the rear panel of LP-PAN for minimum response
- 7) Retune the image to the original center/left point. Readjust the gain setting in PowerSDR for minimum image. Log the value.
- 8) Retune the image to the center/right point and readjust the gain setting for minimum image. Log the value.
- 9) Adjust the gain setting for midway between the two values if they are not the same.
- 10) If the gain settings logged in steps 7 & 8 are not very close (within 2.0), then you can repeat steps 6-9 to get closer.

When finished, image rejection should remain at 60dB or more over most of the range as you tune, with maybe a bit lower at the edges and very near the center, depending on sound card. Results will be better with 96 kHz cards because of the smaller bandwidth. Scott also plans to add auto image nulling in PowerSDR along the lines of what is done in the Rocky program. This would provide an image rejection of close to 100dB with no adjustments.

You should now be ready to attach the enclosure top, and continue with the remaining software adjustments.

Global Offset adjustment – LP-Bridge provides an offset value to PowerSDR which keeps the IF center frequency of PowerSDR synchronized with the K3. Due to slight differences in the reference oscillator in the K3 and the local oscillator of LP-PAN, you must make a small adjustment to bring the two into exact zero beat. The error will generally be within +/-100 Hz of nominal to start with. Starting with serial # 208, the nominal offset will be 6000, which includes an intentional 6 kHz offset. This was done to move the center of the passband slightly to avoid problems with some older or cheaper sound cards which have difficulty near an audio frequency of 0 Hz. On earlier models without the additional offset, the nominal value will be 0.

Installation and Setup cont'd

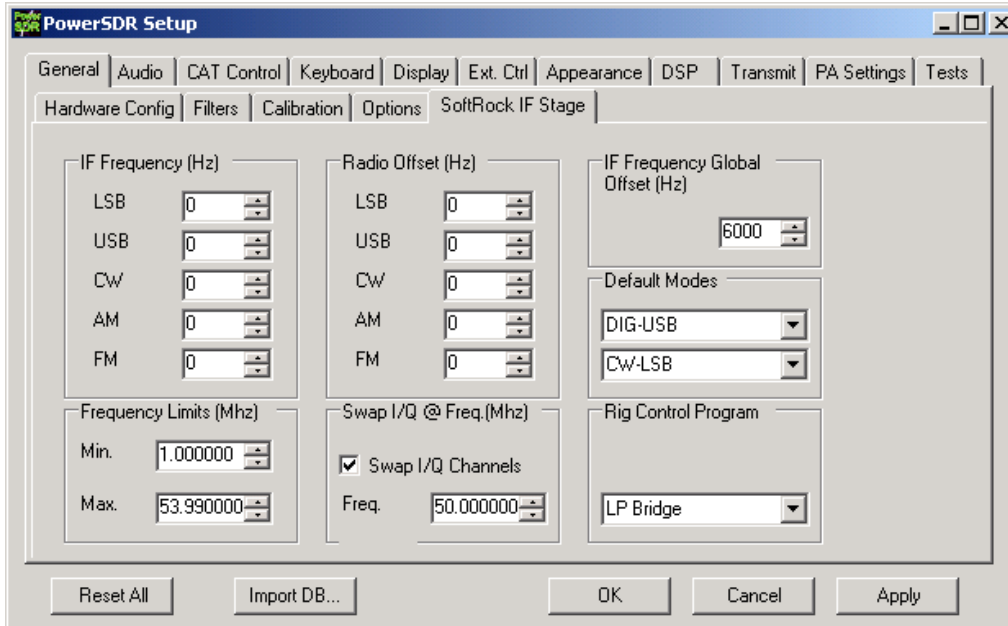

To fine tune the Global Offset, tune in a carrier to a comfortable pitch on the K3. Turn the volume of the sound card monitor up so that you hear the output of PowerSDR at about the same level as the K3. The two tones should be similar, but probably not exactly the same pitch. Adjust the Global Offset control in PowerSDR until the beat note between the K3 and PowerSDR is 1Hz or less. This setting will work for all modes.

CW Pitch adjustment – Another adjustment that must be made is for CW Pitch. There are three adjustments that affect pitch, in addition to the Global Offset adjustment that you just performed. One is in the K3, one is in PowerSDR and the last is in LP-Bridge. Briefly, they should all be set to the same value. The CW Pitch adjustment in PowerSDR appears on the main display whenever a CW mode is selected. It is in the section called “Mode Specific Controls”, under the panadapter window.

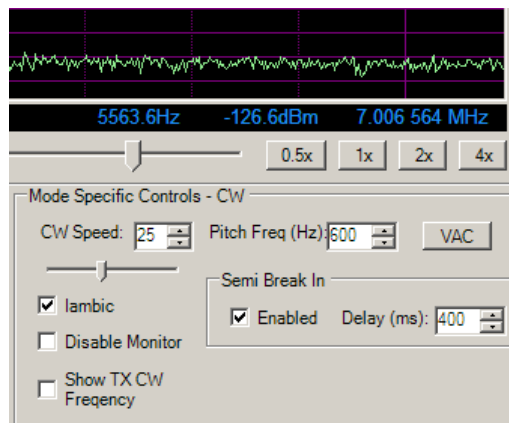

As soon as Elecraft adds the promised CW Pitch command in the K3, this adjustment will be automated.

Operation

LP-Bridge Operation

Normal View

Menu Bar... Along the top of the window. There are three pulldown menus.

File: Only has one choice, "Exit". You can also exit cleanly by using the X in the upper right of the LP-Bridge window. Your current settings are saved on exiting.

Setup: Can be set for "Show" or "Hide". Normally, it is left on Hide unless you want to change a setting or run diagnostics on a port.

Help: "Web Help" will display a link to this page. "About" displays version and copyright data for LP-Bridge.

K3 Port... This is the area where you select the port that your rig is connected to. The K3 must be set for a baud rate of 38,400, which is the maximum connection speed for the rig. **Warning: If you are using a USB to serial adapter, it is recommended that it use an FTDI chipset. The KUSB adapter sold by Elecraft does not, and will likely cause problems.**

Click on "Connect" to connect to the K3, and "Disconnect" to disconnect. If you have a virtual port open when you try to disconnect, you will get an error message to close the virtual port first. If there is a problem connecting to the rig, you will also get an error message. Check cabling and K3 settings if this occurs. If connection is successful, the row of boxes grouped under the "K3 Status" heading will fill with data. This is mostly the data that is linked to PowerSDR, but can also be used to verify proper connection to the K3. The current firmware versions loaded into your K3 are also shown. The "Auto Connect" checkbox is grayed out for now, but will eventually allow LP-Bridge to automatically connect to the K3 when the program starts.

Virtual Port 1-3... This is the area where you select the ports that LP-Bridge will provide for connecting various applications to the K3. Ports can be any port that is not already used on your system. When selecting a port to use, you must avoid all real and virtual ports which already exist, such as those used by USB adapters, devices such as microHam, etc. Select a port number and click Connect. If the connection is successful, the button name will change to "Disconnect". If not, you will get an error message. If there is no connection to the K3, you will also get an error message to connect to the K3 first.

Applications which will connect to this port must be set for the selected port number (not the K3 physical port number). Additional settings should be 38,400 baud, 8-bits, no parity and 1 stop bit (38400,8,N,1). If the application has a polling rate, it should be set fairly fast. I use 200ms for most of mine, but if you have an older computer and it bogs down at that setting, a slower one can be used. Loggers which require minimal data can be set as low as 1 second. Programs which require interactive tuning, or have an S-Meter display should be to a fast setting.

Handshaking should be set how you would normally for connecting to the K3, ie. if you are using DTR or RTS for PTT or CW keying, you would leave these settings as they would be if connected to a K3. Keying signals from multiple applications will all key the K3 in parallel. It is assumed that only one keying application would be in control at any time.

Once again, "Auto Connect" is currently grayed out. There is also a choice for each virtual port to accept "AI1" (Auto Information) from the K3. VPort1 also allows using "AI2" for applications that require it. Some applications don't poll for data, so the K3 has to initiate the comms dialog using one of the Auto Information modes. Checking this setting provides a way for them to do that. If in your testing you find your application does not update when tuning the K3, try checking either "AI1" or "AI2". In my testing, I found that Logic8 requires "AI1", and N4PY's Pegasus requires "AI2". TRX-Manager can be set up to use polling or "AI2". Other programs I have tried that don't need these settings include CW Skimmer, DXLabs' Suite, N1MM, MixW, Logger32, Wintest, DX4WIN and HRD.

In addition, there is a little text box for each virtual port which will allow you to type a program name to help you remember which application is connected to that port. LP-Bridge will remember these titles.

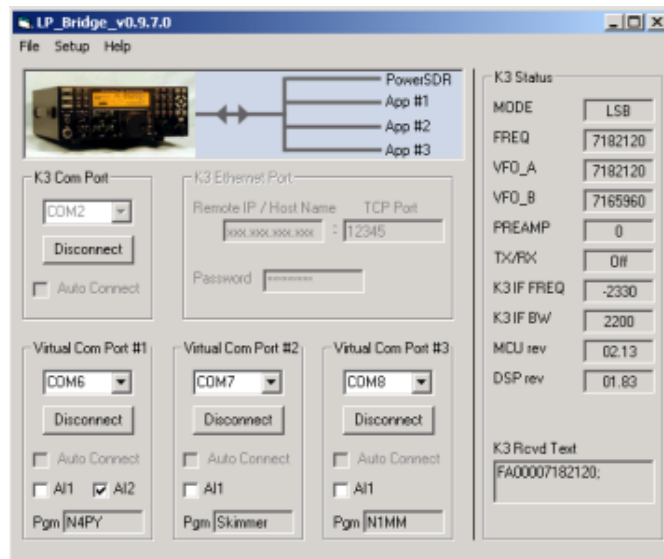

Operation cont'd

LP-Bridge Operation

Setup View

Terminal Windows... These let you view traffic to and from the K3 for the serial port, and to and from applications for the virtual ports. Each window shows the last 100 comm events, and can help you track down a problem. For instance, if an application is not polling for a certain command, or you want to verify that it is getting a response that is not being properly displayed. To scroll through the data, you must disconnect or stop the application from polling, at which point you can scroll through the lines and look for your problem.

Setup... This area provides a place to choose your settings. These include...

Preamp, Attenuator and CAL: Allow you to set the panadapter vertical scale offsets so that the displayed levels are correct whether the K3 preamp or attenuator are on or off. Not implemented yet.

On Top: Allows you to set LP-Bridge to display on top of other applications at all times.

Polling: Sets the polling rate for LP-Bridge. This largely determines the tuning "feel", and S-Meter update speed for programs which need this. The default is 200ms.

CW Pitch: This is a temporary control which provides a workaround to a bug. Once this bug is fixed, the control will disappear. Enter your CW Pitch to match the setting on the K3 and PowerSDR. The LP-Bridge default is 600 Hz.

DDE Diagnostics... This allows testing of the link to PowerSDR. The K3 must be disconnected to use these. If the link is working properly, you can select modes, enter frequencies (in Hz, ie. 14150000), etc. to verify that PowerSDR follows your commands. PowerSDR should respond with return data in the DDE Rcvd Text window.

Again, once you have set the settings, you can hide the setup portion of LP-Bridge.

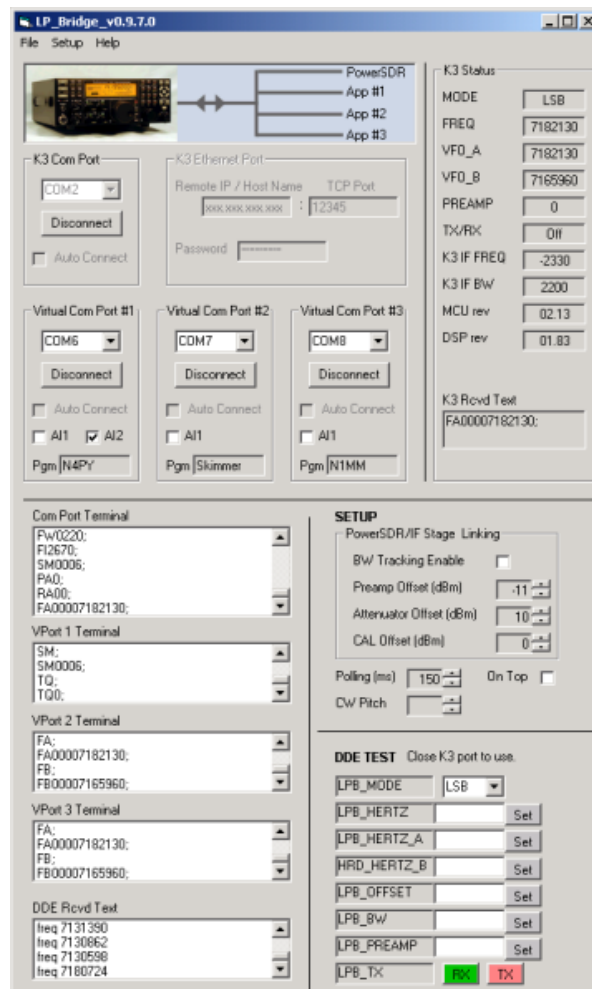

Operation

PowerSDR Operation

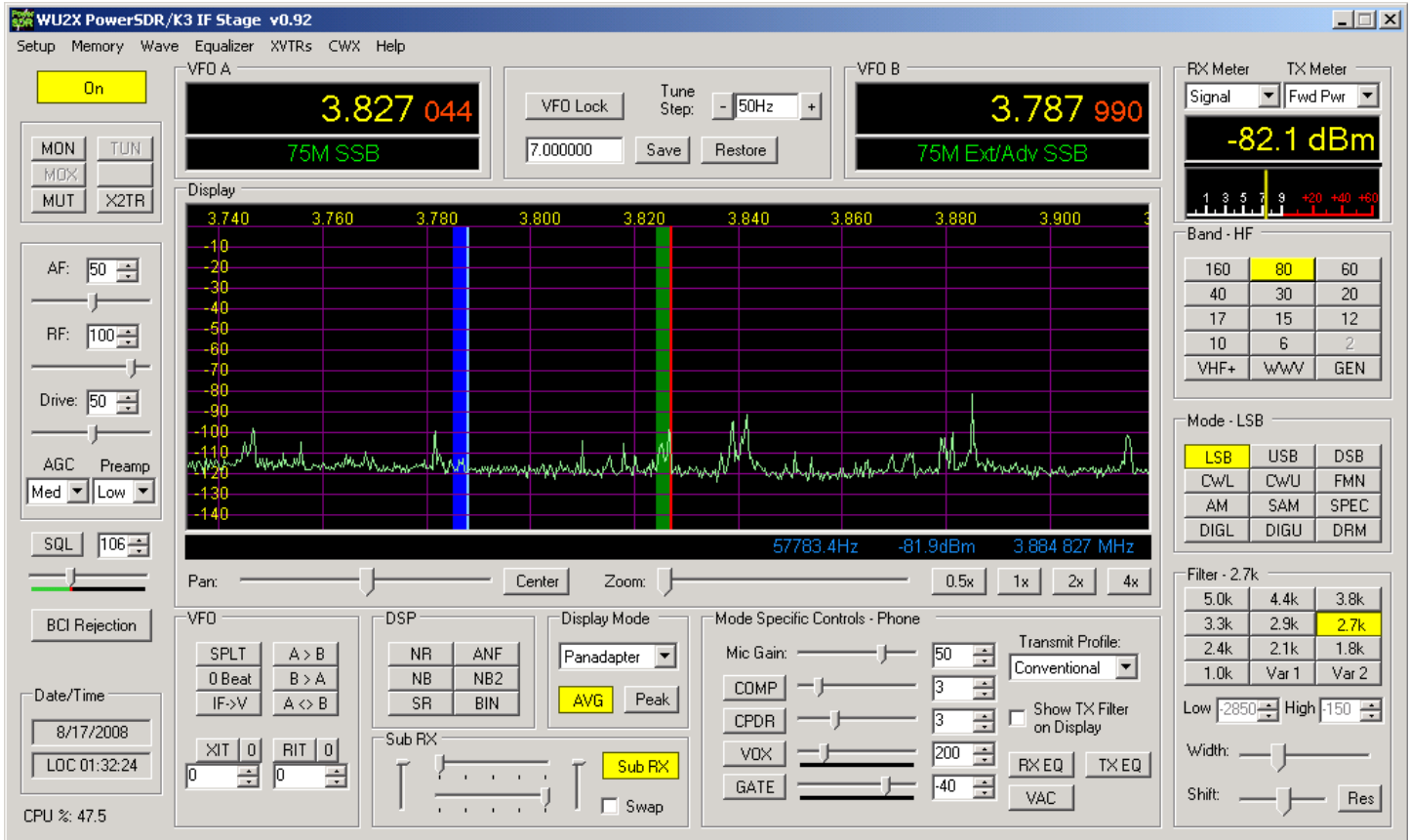

Above is the normal PowerSDR-IF Stage display. Most of the controls are not active for LP-PAN use, including all transmit controls.

MUT, MON... The term mute in context with PowerSDR means the muting of the audio output of PowerSDR when transmitting. If you use LP-PAN only as a display, mute has no real meaning. Normally, mute is a software function handled by LP-Bridge and PowerSDR. It can be disabled by selecting MON in PowerSDR if you want to hear your transmit signal. PowerSDR always displays the spectrum of your low level transmit signal. Hardware mute is also provided by LP-PAN, but will not be needed by most operators. In general, LP-Bridge will provide fast enough muting to handle muting in software for VOX or semi-break-in CW keying. This is not the case with HRD, which has a sizable delay. If you require faster or special muting, contact TelePost support for suggestions on using hardware mute.

AGC... Adjusts the AGC setting for PowerSDR reception only (not K3).

Preamp... Adjusts the vertical scale to correspond to the K3 preamp condition. LP-Bridge is required for this to happen automatically. With K3 preamp "OFF", the PowerSDR mode should be OFF. With the K3 preamp ON, the PowerSDR mode will be "Low".

DSP Section... These apply only to PowerSDR reception.

Sub Rx Section... Applies to PowerSDR receiver channels. The vertical sliders do nothing, the horizontal ones allow panning of the main and sub receivers to left and right speakers. When Sub RX is on, there are two passbands displayed... green for main and blue for sub. Green is linked to VFOA and blue is linked to VFOB.

Display Mode... A number of modes exist, including Panadapter, Audio Scope, Waterfall, etc. Also, AVG and Peak modes of display are selected here. Applies only to display.

Band... Selects band for both PowerSDR and K3. This can be used as a quick way to change bands.

Mode... Selects mode for both PowerSDR and K3. Modes not supported in K3 are ignored by K3. Modes such as DRM require additional software to decode. SAM is Synchronous AM mode.

Operation cont'd

Filter... Selects PowerSDR DSP filters. These can be set differently than K3 if desired (for instance to listen to a wider CW passband than what is selected in K3).

Width and Shift... Apply to PowerSDR IF shift controls.

RX EQ... enables graphic equalizer for PowerSDR receiver. The equalizer can be set in the Equalizer pull down menu at the top of the program.

RX Meter... allows several different modes for the S-Meter

Pan & Zoom... adjusts the portion of the passband that is displayed in the panadapter. Wide display is far left in zoom bar, PAN should be centered.

In normal operation, The panadapter sliderule display moves as you tune the K3. You can also left click and drag the display to tune the K3. Right clicking will display a crosshair which can be used for "point and click" tuning to the signal under the cross hair. Left clicking while the crosshair is centered on a signal will snap that signal into the passband of both PowerSDR and the K3. You can fine tune using the thumbwheel on your mouse, or the main tuning on the K3. You can listen to just the K3, or to just PowerSDR or both. If the global offset has been set properly, they should sound the same.

Currently, PowerSDR-IF Stage does not support tuning of the sub receiver from the K3's VFO-B knob, except in an alpha release. It will be supported in the next release. Support for this already exists in LP-Bridge. When it's supported, VFOB will be linked to the sub rcvr. Click on SubRX to activate it. Normally, the main receiver audio goes to the left speaker and the sub receiver audio goes to the right speaker. You tune the sub receiver by grabbing the blue passband bar and sliding it left or right, or tuning VFOB on the K3.

LP-Bridge provides IF offset feedback from the K3. This is needed because of the various filter offsets, as well as during adjustment of the K3's DSP controls. As the controls are adjusted, the 1st IF signals shift within the K3 passband. These shifts are corrected later in the K3's DSP, but of course that doesn't help the panadapter. The trackig offset feature of LP-Bridge keeps the PowerSDR IF centered with the K3 IF, even when adjusting the DSP shift control or changing filters in the K3. When adjusting IF Shift while tuned to a carrier, you will notice a little "warble" in the PowerSDR audio. This is caused by the latency of the serial connection to the K3 creating a delayed correction for PowerSDR centering. It is barely noticeable on normal signals.

Using LP-PAN with CW Skimmer

First, make sure that LP-Bridge/PowerSDR are set up correctly, and that the offset tracks between the K3 and PowerSDR (signals tuned in on the K3 match the pitch of signals tuned in on PowerSDR). This is covered in the manual under the Global Offset calibration.

Open CW Skimmer > Settings. On the Radio tab, Set the Skimmer Hardware Type to SoftRock-IF. Set the Skimmer Sample rate to match the rate used in PowerSDR. Ignore the other settings on this tab for the moment.

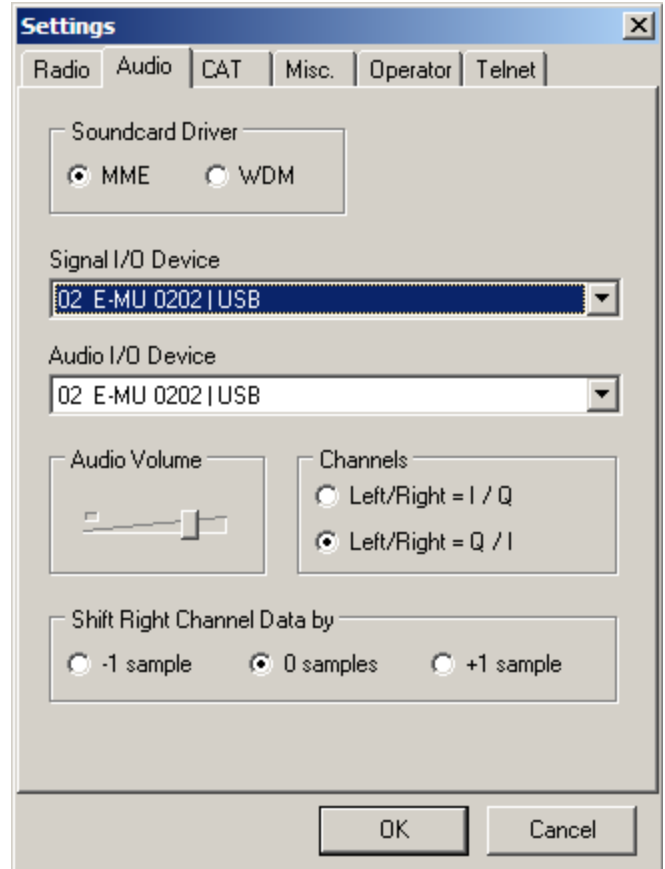
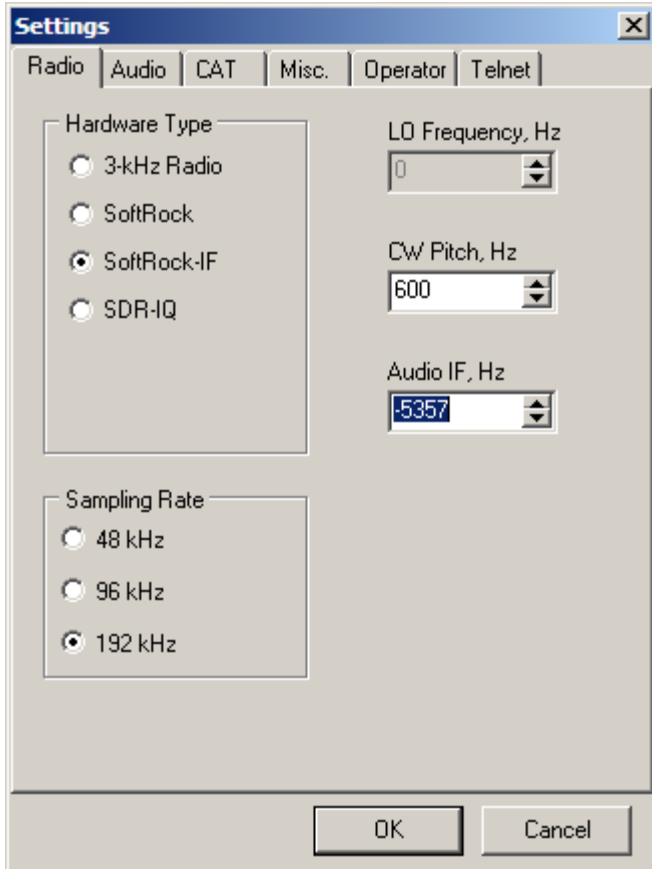

Click on Audio tab, and select driver. This depends on the sound card used. For the E-MU 0202, you must use MME in both Skimmer and PowerSDR. For the E-MU 1212m, use ASIO in PowerSDR and WDM in Skimmer. For Quartet, use ASIO in PowerSDR, and whichever driver works best in Skimmer.

Select the proper input and output sound card. If you haven't already, set Left/Right = Q/I in the Channels section. Check that "Set Shift Right Data Channel" is set to 0.

Click on Radio tab again. Unless you plan to actually listen to the output of Skimmer (not usually the case), the "CW Pitch, Hz" setting can be left at the default of 600Hz (or any other value).

Set "Audio IF, Hz" using the following formula...

$$\text{CW Pitch} - \text{Global Offset} = \text{Audio IF, Hz}$$

CW Pitch is the setting used on the K3, LP-Bridge and PowerSDR (they should all be the same). Global Offset is the setting in PowerSDR. This will get you very close. You can fine tune by clicking on a signal, and comparing the resultant pitch on the K3 to the sidetone using the Spot button. Make sure the DSP controls on the K3 are set to NOR. I'm not sure where the residual error comes from, but I suspect it has something to do with clocking errors between PowerSDR and Skimmer. It might also be due to differences in the ASIO, MME and WDM drivers. At 192 kHz, an error of a few hundred Hz could easily appear.

Note: The setting will only be dead accurate for one filter, especially if the filter is a 5-pole, although the 8-pole filters have a slight offset as well. Also, Adjusting the DSP controls off of NOR will shift the Skimmer display. I am working on Alex to support the Global Offset link from LP-Bridge to avoid this issue.

Circuit Description

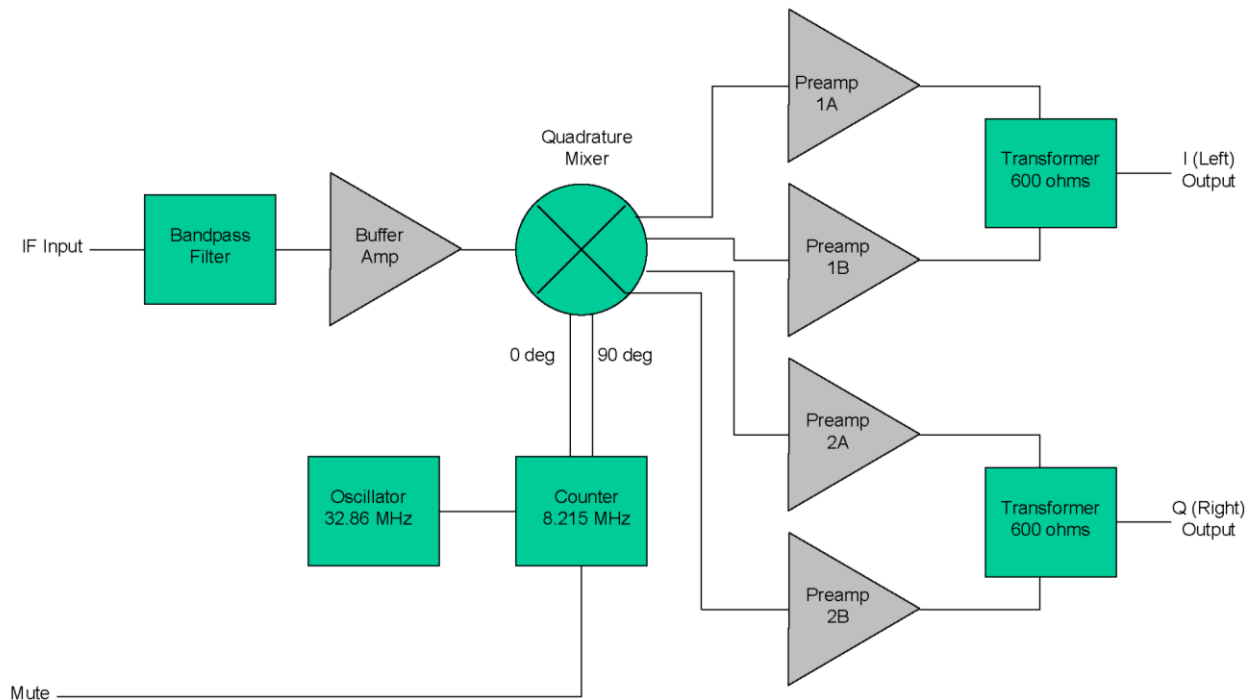

LP-PAN Block Diagram

LP-PAN is a direct conversion quadrature receiver with baseband audio In-Phase (I) and Quadrature (Q) outputs. These outputs are fed to a high quality sound card for DSP processing in applications such as PowerSDR. The input is taken from the IF output connector of a receiver. Values shown are for Elecraft K3. The signal has a very wide bandwidth, and is bandpass filtered down to about 400 kHz in the front end of LP-PAN. This helps with out of band signals that are strong enough to get by the K3's input filters, and also blocks mixer products that are present in the K3's IF output.

The filtered signal is then sent to a high isolation buffer amplifier. This amp serves a couple purposes. One is to add gain lost in the K3 IF output stage, which is quite lossy. The second is to isolate the K3 from the strong L.O. signal present at the input of the quadrature mixer. The buffer amp has over 80 dB of isolation, and is capable of reducing the L.O. leakage to a level well below the K3's noise floor in combination with the K3 internal buffer. The buffer has a very low noise figure, and high IP3 (>+40dBm) so as to not degrade the excellent IMD performance of the K3.

The quadrature mixer is operated in a doubly balanced configuration and provides balanced outputs to the preamps. Very low noise preamps with rail-to-rail outputs were chosen to maximize dynamic range. The preamps are direct coupled to a pair of very broadband transformers to preserve the balanced nature of the design, and minimize 2nd harmonic distortion. The outputs of the transformers can drive either balanced or unbalanced loads. The output Z was chosen to be low (600 ohms) to allow driving almost any sound card. I include internal 2K loads to set a maximum load Z when used with very high impedance sound cards, and present closer to 600 ohms with more typical sound card loads. The load values were chosen experimentally for maximum gain and phase flatness, and one is adjustable to facilitate matching the channels exactly. This is critical in achieving 60dB broadband image rejection with decoding applications which only have a single gain and phase balance adjustment.

By the selection of high quality precision parts, LP-PAN provides a gain flatness of < 0.5% over the 100 kHz bandwidth of the audio chain, as well as a peak-to-peak phase error of under 0.5 degree. This contributes greatly to the high image rejection of LP-PAN, even with programs that use only one setting for gain/phase correction, like PowerSDR. With programs like Rocky, which use dynamic gain/phase compensation, image rejection is about 90-100dB.

Schematic

Note: A high resolution version of the schematic is available on the LP-PAN web page next to the think for the manuals.

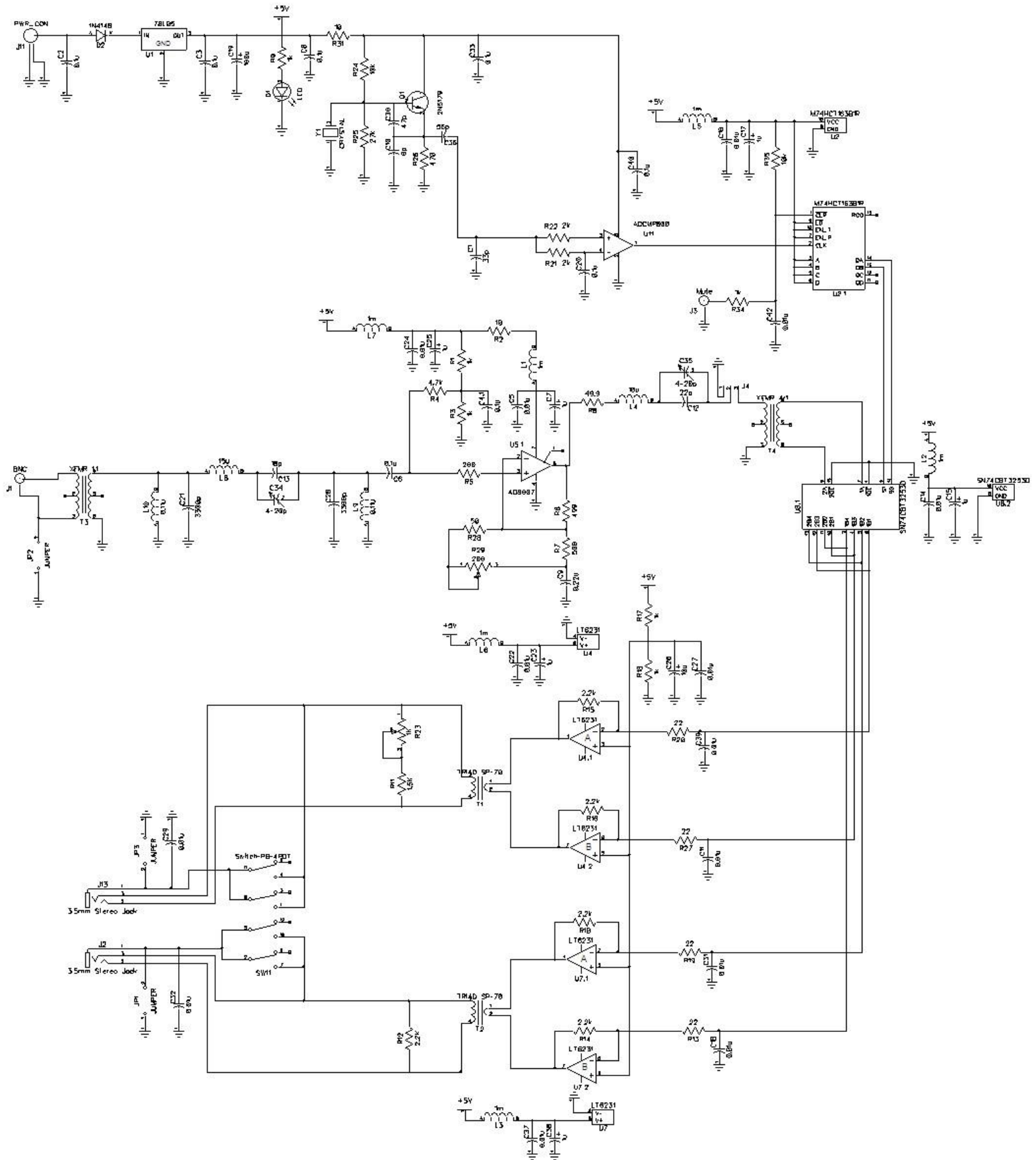

Troubleshooting

Below are some problems that have been reported, and some suggested solutions. If you still have a problem, I am always available by email at larry@telepostinc.com and the LP-PAN Yahoo Group is available at <http://groups.yahoo.com/group/LP-PAN/>

Problem	Suggested solution
Display shows noise but no signals	<ol style="list-style-type: none"> 1) Check audio and RF cabling. 2) Make sure the correct sound card is selected in PowerSDR
There are two sets of signals that move in opposite directions as I tune, ie. there is no image rejection.	<ol style="list-style-type: none"> 1) Check that you are getting equal audio from both I and Q channels. 2) Adjust image rejection per the procedure in the Setup/Calibration section. 3) Check cabling.
The audio in PowerSDR drops out frequently	<ol style="list-style-type: none"> 1) Increase audio buffer size to the maximum value in Setup>Audio tab. 2) Read the excellent paper "Vista Tuneups for LP-PAN", written by Dave, W8FGU, and available on the LP-PAN User Group Files section at http://groups.yahoo.com/group/LP-PAN/files/. It is useful for XP as well.
When I start PowerSDR, the audio "motorboats".	Go to Setup>Audio tab, and check the "Expert" box. Click OK to the warning, then check the "Manual" box and set latency of 2 ms or more as needed to stop motorboating.
There is a "hump" or "hole" in the noise floor near the center of the display.	<ol style="list-style-type: none"> 1) Check your cabling for loose connection which could cause hum. 2) Play with the settings of the Bal/Unbal switch and "ground lift" jumpers. 3) Make sure you are using a recommended sound card.
The center frequency in the display does not match the rig frequency.	Perform the "offset" adjustments in PowerSDR per the procedure in the Setup/Calibration section. Make sure your settings match the picture exactly, except for the Global Offset which will vary from rig to rig.
I don't see my sound card listed under the available sound cards in the Audio setup tab.	<ol style="list-style-type: none"> 1) Check that your sound card is properly installed. You can do this in Device Manager. 2) It is wise not to make your LP-PAN sound card the Windows default. This can be checked under "Sounds and Audio Devices" in the Windows Control Panel. 3) Update your sound card's driver to the latest available from the manufacturer's website. 4) If your sound card is USB, it is usually recommended to have a USB 2.0 port. Use of a USB router for a sound card is not recommended. 5) Try all available drivers in the Drivers selection in PowerSDR>Setup>Audio. ASIO is the preferred driver if available, followed by WDM and then MME or other. ASIO is generally required for 192 kHz sampling.
E-MU Sound card will only work at 48 kHz	Make sure your USB ports are 2.0. The E-MU defaults to 48 kHz with USB 1.1 ports
E-MU was working at 192 kHz, but after upgrading XP to SP3, it only works at 48 kHz now.	This appears to be a MS bug with SP3. Uninstall both E-MU driver and PowerSDR, reboot, reinstall driver and PowerSDR.
I can't get the rig to go to 6m when connected to PowerSDR.	Go to Setup>General>Softrock IF Stage and set Frequency Limits Max to 54.0000000
Frequency doesn't display properly in PowerSDR when using non-English Windows settings.	Use Regional settings to choose U.S. English settings, or to set number format so that comma is decimal point and period is thousands divider.
You are getting erratic frequency and mode jumps	<p>Try a slower polling rate.</p> <p>If you are using a USB to serial adapter, it is recommended that it use an FTDI chipset. The KUSB adapter sold by Elecraft does not, and will likely cause problems.</p>

Support is available from TelePost at larry@telepostinc.com anytime, or 734-455-3716 during normal business hours.

There is also a Yahoo User Group at <http://groups.yahoo.com/group/LP-PAN/> with a large number of helpful users.

Specifications

After factory calibration. Preliminary data subject to change without notice.
(sound card dependent... measured with Infrasonic Quartet PCI sound card)

K3 includes N8LP buffer mod. Noise floor and single tone dynamic range are about 6dB worse without K3 buffer mod.

- * Approx. -130 to -135dBm dBm noise floor with K3 preamp on
- * +2dBm maximum input with K3 attenuator on
- * ~115dBm single tone dynamic range from noise floor to clipping point
- * 50-70dB typical image rejection with PowerSDR-IF, 100dB+ with PowerSDR-IQ.
- * Better than +20dBm IP3 with two -15dBm signals spaced 2 - 20 kHz (composite value for K3/LP-PAN combo)
- * THD ~ 0.005%
- * L.O. leakage, -110 dBm to -140 dBm (buffer inside K3 provides additional ~50dB)
- * 600 ohm output Z, balanced or unbalanced.
- * +2dBV (1.27 Vrms, 3.6V p-p) nominal output level at recommended maximum RF input
- * 8215 kHz L.O. standard (8209 kHz starting with 3rd run). 8830 kHz, 9000 kHz, 4920 kHz and 10.7MHz also available
- * 11-16 VDC @ 53 mA
- * Dimensions: 5.125"(13.02cm) Deep x 5.375"(13.65cm) Wide x 2.125"(5.4cm) High

Note: Specifications dependent on sound card, and subject to change. Cited values were taken with a Infrasonic Quartet PCI sound card, but the results are similar with E-MU 0202 USB or E-MU 1212m sound cards. All measurements also apply to M-Audio Firewire Audiophile card (up to 96 kHz) or Audiophile 2496 PCI card (up to 96 kHz). Measurement details are included in the Performance section below. PowerSDR™ is an open source application for use with IQ based software defined radios, and is a trademark of FlexRadio Systems.

For more performance measurement data, see the LP-PAN page on the TelePost Inc, website, at <http://www.telepostinc.com/LP-PAN.html>

For an up to date comparison of sound cards, check out the Sound Card page on the TelePost Inc, website. at <http://www.telepostinc.com/soundcards.html>

Warranty

Factory assembled LP-PANs are warranted against failure due to defects in materials and workmanship for one year from the date of purchase from TelePost Inc. Warranty does not cover damage caused by abuse, accident, improper or abnormal usage, improper installation, alteration, lightning or other incidence of excessive voltage or current.

Units built from kit are only covered against failure due to defects in materials, with the further limitation that any parts damaged as a result of improper kit assembly are not warranted. Parts delivered damaged or missing will be replaced by TelePost Inc. at company's expense, including shipping.

If failure occurs within the warranty period, return the LP-PAN to TelePost Inc. at your shipping expense. The device will be repaired or replaced, at our option, without charge, and returned to you at our shipping expense. Repaired or replaced items are warranted for the remainder of the original warranty period. You will be charged for repair or replacement of the LP-PAN made after the expiration of the warranty period or where, in our reasonable opinion, the damage is due to improper assembly of the kit.

TelePost Inc. shall have no liability or responsibility to customer or any other person or entity with respect to any liability, loss or damage caused directly or indirectly by use or performance of the product or arising out of any breach of this warranty, including, but not limited to, any damages resulting from inconvenience, loss of time, data, property, revenue or profit, or any indirect, special incidental, or consequential damages, even if TelePost Inc. has been advised of such damages.

Under no circumstances is TelePost Inc. liable for damage to your amateur radio equipment resulting from use of the LP-PAN, whether in accordance with the instructions in this Manual or otherwise.