

# LP-100

## Digital Vector HF Wattmeter



## Operating & Assembly Manual

April 2007  
TelePost Incorporated  
Rev. C20

# Compliance Statements...



## Federal Communications Commission Statement (USA)

This device complies with Part 15 of the FCC Rules. Operation is subject to the following two conditions: (1) this device may not cause harmful interference, and (2) this device must accept any interference received, including interference that may cause undesired operation.



## European Union Declaration of Conformity

TelePost Inc. declares that the product:

**Product Name: Digital Vector RF Wattmeter**

**Model Number: LP-100**

**Conforms to the following Product Specifications:**

**EN 55022: 1998 Class B**

following the provisions of the Electromagnetic Compatibility Directive 89/336/EEC, tested and verified 3-17-2006 at FCC accredited laboratory.

## Industry Canada Compliance Statement

Canada Digital Apparatus EMI Standard

This Class B digital apparatus meets all the requirements of the Canadian Interference-Causing Equipment Regulations.

Cet appareil numérique de la classe B respecte toutes les exigences du Règlement sur le matériel brouilleur du Canada.

## Copyright and Trademark Disclosures

LP-100 is a trademark of TelePost Inc. Windows® is a registered trademark of Microsoft Corporation. Teflon® is a registered trademark of E.I. du Pont de Nemours and Company. PICmicro® is a registered trademark of MicroChip Technology Inc.

Material in this document copyrighted © 2007 TelePost Inc. All rights reserved. All firmware and software used in the LP-100, LP-100 VCP and LP-100 Plot programs copyrighted © 2004-2007 TelePost Inc. All rights reserved. MicroCode Loader is a copyrighted program from Mecanique, <http://www.mecanique.co.uk/>.

# Table of Contents

Introduction .....	4
Parts List.....	5
Assembly Instructions .....	8
Initial Checkout .....	16
Setup/Calibration.....	18
Operation.....	22
Circuit Description .....	26
Schematic .....	28
Troubleshooting .....	30
Software.....	32
Specifications and CAL Table .....	34
Warranty .....	35
Appendix A .....	36

# Introduction

The LP-100 is designed as an accurate instrument for monitoring station performance. It provides a number of unique features not seen before in a ham radio wattmeter.

The most obvious of these is the vector display. This display shows the complex impedance of the load in two ways. The top line of the display shows impedance in polar form... i.e., magnitude and phase of the impedance. The bottom line shows the real and imaginary components of impedance... i.e.,  $R + jX$ . The parameters are displayed in a range of 0.1 to 999.9 ohms. Phase is displayed in 0.1 degree increments from 0-180 degrees.

Features include...

- PLED display with bargraphs for power and SWR, along with numerical readout for both
- Professional dBm / Return Loss display
- 50 mW to 2500W with four autoranging scales
- Power display resolution of 0.01 to 1W depending on scale
- Frequency coverage of 1.8-54 MHz, with automatic band-by-band compensation
- Z, R, |X| display from 0-999.9 ohms each
- Separate coupler with 50 ohm ports for uncluttered desktop
- Peak-hold numerical power readout with "hang" characteristic for power and SWR
- SWR accuracy < .15 (5%) from about .1W to 2500W, .05 typical
- Power accuracy is 5% typical at any rated power level or frequency from .5W to 2500W after calibration, usable to 0.05W
- Can be easily matched in the field to external standard to within 0.1% on each band
- Power display is actual power delivered to the load ( Fwd minus Ref power).
- SWR Alarm system with set points for Off, 1.5, 2.0, 2.5 and 3.0.
- Windows freeware Virtual Control Panel for software / remote control
- Support within TRX-Manager for direct remote monitoring
- Advanced charting capability for SWR, RL, Z, R, X and phase angle vs. frequency
- Built-in bootloader to allow for firmware upgrades to be downloaded and installed.
- Call sign screen saver to extend life of display
- Direct input for bench testing & field strength measurements, -15 to +33 dBm.
- Conforms to FCC Part 15 A & B, ICAS and CE radiated emission limits, tested and verified by accredited lab

This manual will address the assembly of the LP-100, initial checkout, calibration and operation. You may wish to read through the circuit description and study the schematic before beginning assembly to familiarize yourself with the project. **It is highly recommended that you thoroughly read through the **Assembly** section before even unpacking the LP-100 kit.**

## RoHS Statement

The EU adopted a set of standards for the "Reduction of Hazardous Substances" in July 2006. There is considerable confusion over which devices and companies are affected by the new rules. It is our opinion that home-built kits are exempt from this legislation, and there may well be a further exemption under the heading "Measurement Equipment" for the LP-100. Also, since TelePost does not have a presence in Europe, we do not import to or export from a member State, as stipulated in the rules.

Regardless of these exemptions, every effort has been made to provide 100% RoHS compliant parts, PCBs and SMT assembly processes on the LP-100. We recommend the use of standard Pb/Sn alloy solders for assembly of LP-100 kits, mainly for performance reasons. This is perfectly acceptable under the rules for "own use built equipment (hobbyist)". Use of lead-free solder is also permissible, since the PCBs are lead-free, but be aware that special equipment and techniques are required to use lead-free solder, and PCB rework has a much higher chance of damaging the PCB.

In layman's terms, the LP-100 is as lead-free as possible without compromising performance or long-term reliability, and builders in member States are free to assemble an LP-100 with whatever solder they wish.

## Hardware Upgrades

Starting with serial #101, the LP-100 uses an upgraded PIC processor, with twice the memory of the previous chip. This allows for years of firmware development and added features. Any owner of an earlier LP-100 is entitled to a free upgrade to the new processor, but will need to do an additional calibration to take advantage of the new capabilities. As a convenience to any LP-100 owner, TelePost will do the chip swap and a free recalibration if the owner returns the LP-100 to TelePost at his shipping expense, and pays for return shipping (\$12 for Fedex Ground insured). Alternatively, TelePost can ship a new processor to the owner in exchange for the old one, or for a small charge if the owner wishes to keep the old processor as a backup. In this case, it is up to the owner to recalibrate his meter, and to save and re-program his CAL table into the new chip. For details on chip swapping, send an email to [larry@telepostinc.com](mailto:larry@telepostinc.com).

# Parts List - Subject to change without notice.

## Pre-installed SMT parts

QTY	Part No.	Description
4	C9,10,12,13	0.01uF 50V
2	R4,18	Resistor 26.7 1% .25W
2	R5, 12	Resistor 49.9 1% .5W
2	R6,21	Resistor 56.2 1% .25W
2	R9, 27	Resistor 56.2 1% .5W
2	R10, 20	Resistor 422 1% .25W
1	R24	Resistor 174 1% .25W
1	R30	Resistor 120 1% .25W
1	R33	Resistor 32.4 1% .25W
1	R35	Resistor 75 1% .25W
1	D8	HSMS-2805 dual Schottky diode
1	U1	AD8302
1	U9	AD8367
1	U10	Gali-74 MMIC
1	T1	ADP-2-1 Transformer

## Parts to be installed – main chassis

QTY	Part No.	Description
14	C1,2,5,6,7,11,14, 20,22,32,33,40,42,43	0.1uF 50V marked 104
3	C3,27,41	10uF 50V
1	C4	0.33uF 50V marked 334
8	C8,21,28,29,30,34,38,39	0.01uF 50V marked 103
7	C15,16,17,18,19,31,35	1uF 50V marked 105
2	C23,24	0.001 marked 102
2	C25,26	0.002 marked 202
1	C36	330pF 50V marked 331
1	D2	Rt. Ang. LED Red
1	D3	Rt. Ang. LED Green
1	D4	1N4001
1	D5	1N4148
1	RC1	ribbon cable assembly
2	J1,P1	16-pin DIL header for display
2	J2,7	BNC jack, rt. angle
1	J3	Power jack 2.5mm
1	J4	DB9 PCB mount
1	J6	Dual RCA PCB mount
2	JP1,2	2-pin SIL header
2		Shorting jumper
4	L1,2,3,7	470 uH, 100 mA molded choke (large brown) (yel-viol-br-silver) or 1mH, 100mA molded choke (large green) (br-blk-red-gold)
2	L4, 6	470uH, 30 mA molded choke (small green or brown) (yel-viol-br-gold)
1	L5	1 mH, 30 mA molded choke (medium green)(br-blk-red-silver) or 1mH, 100mA molded choke (large green) (br-blk-red-gold)
1	Q1	2N4401
1	LCD-1	PLED display 20x2
2	R1,13	1M 1% 1/8w br-blk-blk-yel-br
3	R2,41,42	10k 5% 1/8w br-blk-or
3	R3,16,17	1k 5% 1/4w br-blk-red (may be 1/8w depending on board version)
5	R7,11,14,34,36	1k 5% 1/8W br-blk-red
1	R8	20k pot
1	R15	22k 5% 1/8W red-red-or

QTY	Part No.	Description
2	R19,29	4.7 5% 1/4W yel-viol-gold
1	R22	150k 1% 1/8W br-grn-blk-or-br
2	R23,25	10k 1% 1/8w br-blk-blk-red-br
1	R26	6.34k 1% 1/8W blu-or-yel-br-br
1	R31	100 5% 1/8W br-blk-br
1	R32	174 1% 1/8 or 1/4W br-viol-yel-blk-br
1	R37	57.6 1% 1/8 or 1/4W grn-viol-blu-gold-br (blue body)
1	R39	120 5% 1W br-red-blk-blk-br (brown or rust colored body)
1	RL1	Omron G5V-2-H1-DC5
1	S1	CEM-1212C Piezo transducer
3	SW1, 2, 3	4mm tactile switch, rt. Angle
3	Switch keycaps	
1	T2	Toroid core FT37-61
1	U2	LM7805
1	U3	18F2620
1	U4	TLC-271ACP
1	U5	MAX6225BEPA
1	U6	MAX232N
1	U7	LM34DZ
1	U8	MCP3304
1	Y1	Resonator 10 MHz
1	#28 wire for xfmr	(2) 6" (15.24cm) lengths – two colors
1		Pwr Cable 2.5mm
1	Enclosure	Main Enclosure (top & bottom)
1	PCB	Main PCB w/pre-installed SMT parts
1	Heatsink	Heatsink for 7805 regulator
2	IC Socket	8-pin sockets
2	IC Socket	16-pin sockets (Socket not used for the relay)
1	IC Socket	28-pin socket
4	Rubber Feet	Square

#### Parts to be installed – coupler

QTY	Part No.	Description
1	Enclosure	Coupler
1	PCB	Coupler
2	T1, 2	Toroid cores FT140-61
2	UHF Connector	SO-239
2	BNC Connector	UG1094/U
2	BNC cable	6' (1.83m) M/M – RG58U
4	R3, 4, 9,10	75 ohm 1% 1W (2512 SMT)
8	R1, 2, 5-8, 11,12	301 ohm 1% 1W (2512 SMT)
2	Nylon bushings	One with 3/16" (4.76mm) hole, one with 1/4" (6.35mm) hole, 3/16" (4.76mm) & 1/8" (3.18mm) on serial #s after 200)
6	Adhesive Teflon® tape	2 long and 4 short pieces (2 long & 2 short on serial #s after 200)
1	Terminal Strip	2 lug terminal strip
1	#20 wire for xfmrs	(2) 45" (1.14m) lengths
1	RG-142B/U Teflon® coax	(1) 2" (5.08cm) length
1	RG-316U Teflon® coax	(1) 2" (5.08cm) length
4	Rubber Feet	Round
1	Adhesive Label	Coupler Top Label

## Hardware

QTY	Part No.	Description
1		4-40 x 1.5" (3.81cm) threaded standoff (.625" (1.59cm) on serial #s after 200)
1		4-40 x 0.75" (1.91cm) machine screw (serial #s after 200)
14		#4 self-tapping screws – 1/4" (6.35mm) – plated (for coupler)
14		#4 lockwashers (9 for coupler, 3 for main chassis) (11 for coupler, 3 for main chassis starting about serial # 350)
1		#4 split lockwasher for coupler PCB
10		4-40 x 3/8" (9.53mm) machine screws – plated (8 for SO-239s, 2 for DB9) (plus 1 for attaching voltage xfmr standoff starting about serial # 350)
5		4-40 x 1/4" (6.35mm) machine screws – plated (3 for coupler, 1 for heatsink) (1 fewer starting about serial # 350)
9		4-40 nuts – large (for coupler)
4		4-40 nuts – small (1 for coupler PCB, 3 for main chassis)
16		4-40 x 3/16" (4.76mm) machine screws – black (for main chassis)
8		4-40 x 1/4" (6.35mm) threaded standoffs (for main chassis)
6		#4 x 1/4" (6.35mm) self-tapping screws – black (for main enclosure)
1		#4 x 3/8" (9.53mm) self-tapping screw – black (for RCA connector)
1		#4 Solder Lug (2 on serial #s after 200)

You should check all parts before starting to allow you to start the process of obtaining replacement parts as soon as possible. It is also a good idea to sort the parts in advance... egg cartons are handy for this (passive parts only). Michael's crafts stores also have nice plastic cases with dividers at low prices. **Note: parts subject to change without notice. For instance, there are a couple cases where a resistor is called out for 1/8W where the supplied one might be 1/4W, as in R33 & R37. Also, the original part for R39 was a compact 1W resistor where the current part is larger. This is due to sketchy availability of the earlier parts. The PCB layout will be revised in the future if it becomes clear that the original parts will no longer be available. In the case of the larger resistors, just form the leads under the part as shown below if this happens. This can also happen with lead spacing on caps.**

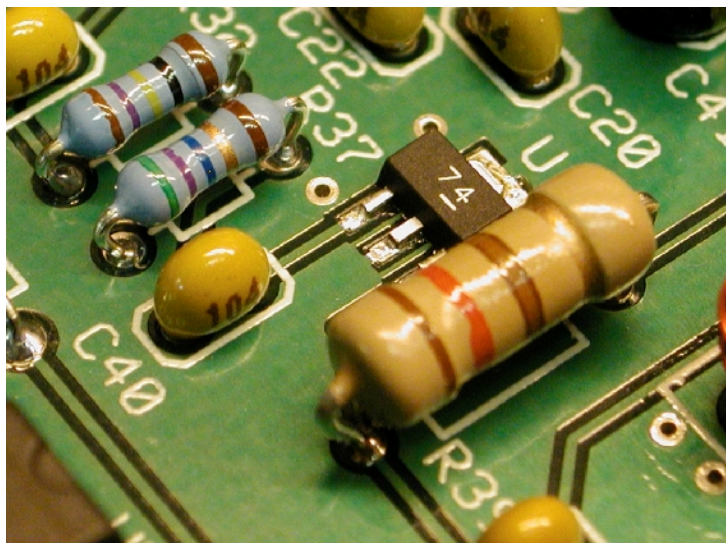
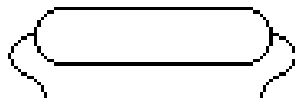

# Assembly

## Important warnings – read this before starting assembly

You should visually inspect all the solder pads/traces with a magnifier for any etching problems. This is done before shipping, but I recommend the builder do a second inspection as well. We also now do 100% continuity checks of all pads before shipment, and I recommend the builder do this as well. This is a result of a couple bad boards found in production run #3. These two steps will take about 15 minutes, but could save a lot of work. To do the continuity check, turn the board upside down, and connect one lead of your DMM to the ground plane. Touch each pad on the bottom that is not a thermal ground pad (one with a "+" shaped connection to the ground plane). None of the normal pads should have continuity to ground except for two near T1, the SMT xfmr, which provides a DC path to ground for those pads. NOTE: the dozens of little "vias" tie the top to the bottom ground planes, and these do not need to be checked as they are supposed to be grounded.

All of the SMT components are pre-installed on the main board for your convenience. SMT parts are supplied wherever necessary for performance or availability reasons. **CAUTION: Be very careful handling this board to avoid damage to the installed parts. Anti-static measures are highly recommended, such as use of an anti-static mat, grounded soldering iron and wrist band.**

You may wish to clean the flux from the board after assembly, although it is not necessary with most modern solders. A toothbrush and alcohol are good for this. Only use rosin core solder. Use of acid core solder voids the warranty. Lead-free solder is OK, and the boards are RoHS compliant, but it will be more difficult to remove parts without damaging the board should you have to.

## Overview

Below is a parts layout of the main PCB. These markings match the silk-screening on the PCB, but are repeated here for clarity. You can also cross out the parts on this graphic as they are installed. **Note: DO NOT use this manual for assembly of kits with serial numbers before #101. Use LP-100 Manual Rev. B listed on the LP-100 webpage at [www.telepostinc.com/lp100.html](http://www.telepostinc.com/lp100.html) instead. Some pictures in this manual are of boards or components from earlier production runs. These may be slightly different than later versions. For instance, L8, R28, C44, and C45 were deleted on later versions, and C27 and J8 were changed.**

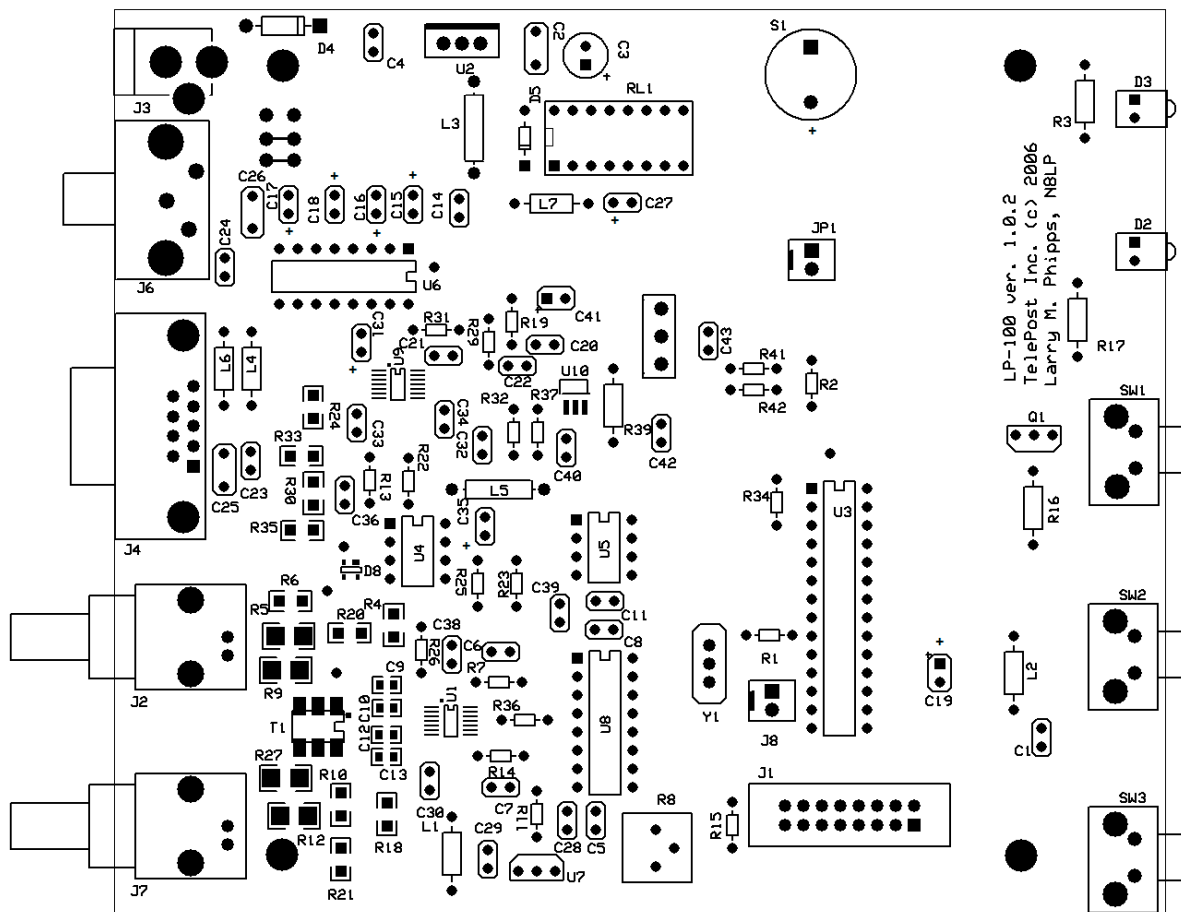



# Assembly cont'd

I recommend approaching assembly in the following order...

- Install all IC sockets
- Install resistors
- Install capacitors
- Install connectors and switches
- Install 7805 regulator
- Install chokes selectively as outlined in the instructions

This allows the board to remain flat during most of the construction. Following this order will also facilitate initial checkout. The chokes will be selectively installed to allow for checkout of various sections of the circuit.

Checkout will follow this order...

- Verify proper +5vdc before powering any devices
- Install L2, PIC and PLED and check display for proper PIC operation
- Install L1, L3, U5, U7 and U8 and verify proper operation of ADC
- Install L5 and U4 and verify proper power detection
- Install L7 and verify proper frequency counter operation
- Install U6 and verify proper serial port operation

The above checks will require only a DVM and the Setup screens except for the power display check. To check the power display, you will need a transmitter and completed coupler. **I will list expected current drain in red at each step so that you can verify that nothing is shorted in each section. A current limited or fused power supply with 0.25 amp maximum fuse should be used during checkout.**

To calibrate the power readings of the LP-100 will require a minimum of an accurate 50-ohm dummy load and a means to measure rf power. You will need a diode peak detector or a calibrated oscilloscope to measure rf voltage across the load. An alternative would be an accurate reference wattmeter.

To calibrate the impedance gain and phase detectors you will also need a 25 ohm dummy load. This can be easily made up out of inexpensive 3W, 5% metal oxide resistors, such as used in my LP-200 or the Elecraft DL-1. Alternatively, you can use a pair of 50 ohm dummy loads with coax adapters to allow them to be paralleled to provide 25 ohms. This calibration can be done with as little as 5W of power. This adjustment is not imperative, as the default value is quite acceptable.

SWR calibration requires setting offset and slope adjustments for the AD8302 gain detector. Calibration of the AD8302 phase detector requires a delay line of known electrical length. You can get pretty close by using a high quality piece of poly dielectric RG-58, and calculate the electrical length in degrees using the following formula...

$$\text{Phase} = (360 * L * F) / (984 * VF)$$

Where Delay is in degrees, L is in feet and F in MHz. VF would be 0.66 for poly dielectric. A convenient length is about 6' (1.83m), which would provide a delay of ~45 degrees (the center of the range) at 14 MHz. You will find more about calibration in the **Calibration** section. I am contemplating an inexpensive calibration kit in the \$25 range, which would include a switchable dummy load PCB and pre-cut delay line. I will also calibrate any assembled LP-100 kit free of charge if you pay for return shipping.

You will need the following tools to complete assembly...

- Adjustable soldering iron – 800 degrees maximum
- 60/40 alloy solder... .020" (0.51mm) diameter recommended for thermal pads
- Needle-nose pliers
- Wire cutters
- Small Philips head screwdriver
- Razor knife
- Digital Multimeter

**NOTE: The LP-100 is what I would call an intermediate level kit. If care is taken, you should have no difficulty building it. I would peg the assembly time at about 8 hours total, plus some reading through the manual in advance, and some time for calibration. Take your time, and double-check your work. A change was made after serial #100 to make the thermal pads to ground easier to solder. The board is now also RoHS compliant. This should not pose any problem. In fact, I find the newer boards easier to solder.**

# Assembly cont'd

## Step-by-step assembly instructions for main board.

Below is a picture of the assembled PCB. The SMT parts come pre-installed.

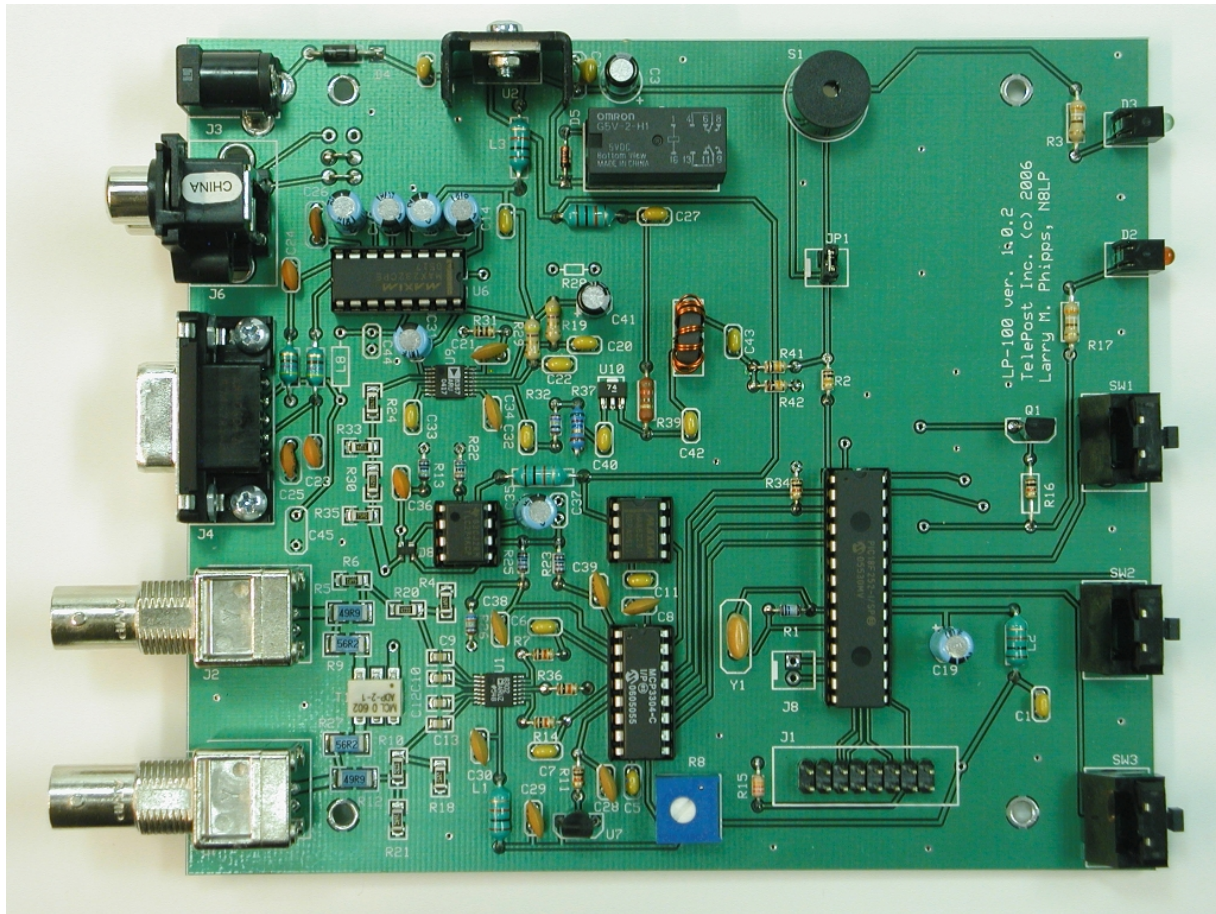

It is recommended that you print this manual to allow for easy reference while building, and to allow you to check off the steps as you complete them. There will also be a table of calibration values you can enter as you do the calibration. This will enable you to return to the original settings should you need to in the future.

Make sure your work area is static-free to avoid damage to the pre-installed SMT parts. It is also advisable to wear an anti-static wrist band. Refer to the parts placement graphic on page 6 or the above picture for questions regarding parts placement. You can zoom into the pdf version of this document for easier parts identification if needed.

- q Install all IC sockets, keeping the board flat as you go to avoid gaps.
- q Install resistors. To avoid messiness when trimming leads, I would do about 6 at a time. If you are unsure of the colors used by some of the manufacturers for the color code, measure the value with a DMM.
- q Install all .01 uF caps (marked 103), in groups of about 6.
- q Install all .1 uF caps (marked 104). This should be done in at least two batches. On some runs, these parts have formed leads. You can straighten the leads are just snap the part in as designed.
- q Install remaining caps, leaving the 10 uF caps for last. Observe polarity on electrolytics. Referring to the component placement guide and picture may help with parts placement, for instance for C27 which was changed to an electrolytic.
- q Install green and red LEDs. NOTE: Do not install these tight against the board. Because of manufacturing tolerances on these parts, they may not line up with the front panel holes when installed tight against the board. It is desirable to leave about 1/16" of spacing below the LEDs, so that they can be bent forward to line up if necessary.

# Assembly cont'd

- q Install miscellaneous parts such as resonator, Piezo transducer, transistor, diodes, etc. **NOTE: Remove the protective covering on the transducer before using. Also, the "+" lead goes to the side with the jumper, per the placement guide. The outside leads of the resonator are interchangeable. Do not install chokes yet.**
- q Install connectors and switches, except for J4, the DB9 connector. You will probably have to prop sections of the board up to ensure that the parts are flush with the board. Install the header on the PLED PCB. The header is installed on the back side of the PLED PCB with the long pins pointing away from the board.
- q Install 7805 regulator. Attach heatsink to the regulator before installing on PCB, using 4-40 x 1/4" (6.35mm)" machine screw and small hex nut. It doesn't matter which side the nut is on.

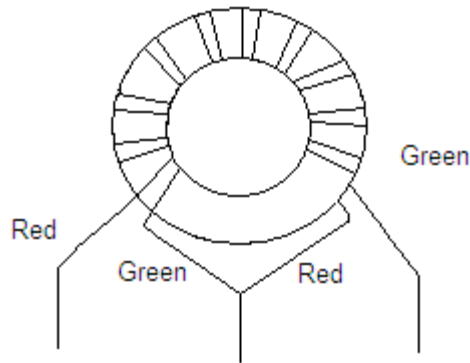

- q Install T2 near C43. This xfmr is made up of 10 bifilar turns of #28 enameled wire wound on a FT37-61 core. Wire is supplied in red and green to make wiring a snap. Bifilar means that the two wires are wound as a pair. See diagram above for wiring. It does not matter if the wires are parallel or twisted. A turn is defined as a pass through the center of the core. You will wind up with three leads, which will be inserted into the three holes indicated on the silk-screen. The lead with two wires goes to the center hole in the PCB. Make sure that the enamel is removed from the leads before soldering to ensure good contact.
- q Install L4 and L6. The remaining chokes will be installed as part of the initial checkout of the board, in order to enable powering up of circuits individually. These may be brown or green, but are smaller than the other chokes. **NOTE: If you check the chokes with a meter like the AADE, the readings may be low. This is because the chokes use ferrite cores, and the L varies with frequency. The little meters tend to test at very low frequencies.**
- q The jumpers for the PTT connector can be wired now. The normal wiring is shown on the component placement diagram at the beginning of this chapter, and below. This provides for a normally closed connection between the center conductors of the two RCA connectors. This will work for most rig/amp combinations. For more options for PTT wiring, check out the SteppIR Tuning Relay section of my webpage.

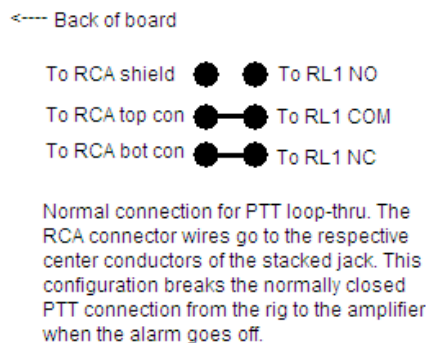

- q Attach J4, the DB-9 connector to the PCB using 4-40 x 3/8" (9.53mm) screws, lockwashers and small hex nuts. The lockwashers and nuts go on the bottom of the board. Solder the pins after tightening the screws to avoid stressing the pins after soldering.
- q You can install RL1 at this time. The correct positioning is with the two separated pins toward the back of the board, next to the snubber diode, D5. The notch in the top is also positioned next to the diode. See the component placement illustration. I used to supply a socket for this, but have decided that there's really no need for it, and there's a risk of the relay working loose during shipment.



# Assembly cont'd

## Initial checkout of main board.

- q Step 1. Make sure that your bench is clean and the PCB is not sitting on any cut off component leads. Connect supplied power cable to a supply of 12-15 VDC. The dashed white lead on the supplied power cable is the +lead (center pin). Make sure you have a jumper installed at JP2. Using your DMM, check for 5.0 VDC at pin 3 of U2. The voltage should be within 0.25V of 5.0 VDC. **~7 mA**.
- q Remove power and install L2, U7, Y1 and the PIC. Temporarily connect the PLED display. Be careful to make sure there is nothing on your bench which could short out anything on the PLED PCB. The ribbon cable should be oriented as shown in the interior photo below. Make sure that the ribbon connectors are centered on the headers at both ends.



- q Step 2. Power the board up again, and verify that you are seeing the “splash” screen with version and copyright information, followed by the main LP-100 screen. The main screen should look like the screen on the photo at the top of the “Operation” section of this manual. If you don't see the display, adjust the setting of R8. The proper setting is just at the point where the display reaches maximum brightness. This will ensure that the brightness drops to the proper level when the first step of the screen saver timer is reached. A finer adjustment can be made after the screen-saver starts. The correct voltage for the PLED at the junction of R8 and R15 is 3.0V at full brightness **while displaying the main screen**. It will drop to 2.4 – 2.5V in the screen saver mode. **~35 mA**
- q Step 3. Install L1, L3, U5, and U8. **~82 mA**. Temporarily enter the Setup mode by briefly pressing the Mode (SW1) and Alarm (SW2) buttons almost simultaneously. The Mode button should be pressed slightly ahead of the Alarm button. **NOTE: Starting with firmware version 1.1.44, entering (or exiting) Setup is accomplished by holding the Mode button for about a second until the screen changes.** You should now see the first Calibrate screen, shown below for firmware prior to 1.1.47. The second screen is for firmware 1.1.47 and after. This screen shows the reference voltage generated by U1 (the gain/phase detector), the Received Signal Strength Indicator voltage from U9 (the AGC chip) and temperature in degrees F and C (from the temp sensor, U7). **Note: the RSSI reading shown in this photo is with RF power applied. The resting voltage with no RF is generally between .150 and .250. Newer firmware displays Temp in degrees C or F depending on the selection.**

```
Ref  RSSI  TmpF  TmpC
1.83  .527  084.4  29.1
```

```
Re 1.82 AGC .131 69F
AL:Reset FS:TempF/C
```

- q Step 4. Install L5, L7, U4 and U6 and check the current. **~160 mA**. If all is well, set the board aside until the coupler assembly is completed to allow checkout of the power detector circuit and frequency counter.

# Assembly cont'd

Step-by-step assembly instructions for the coupler.

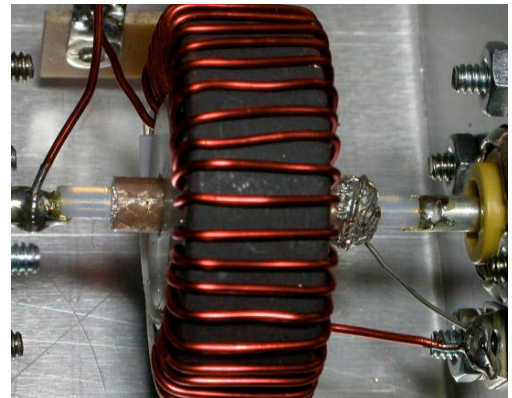
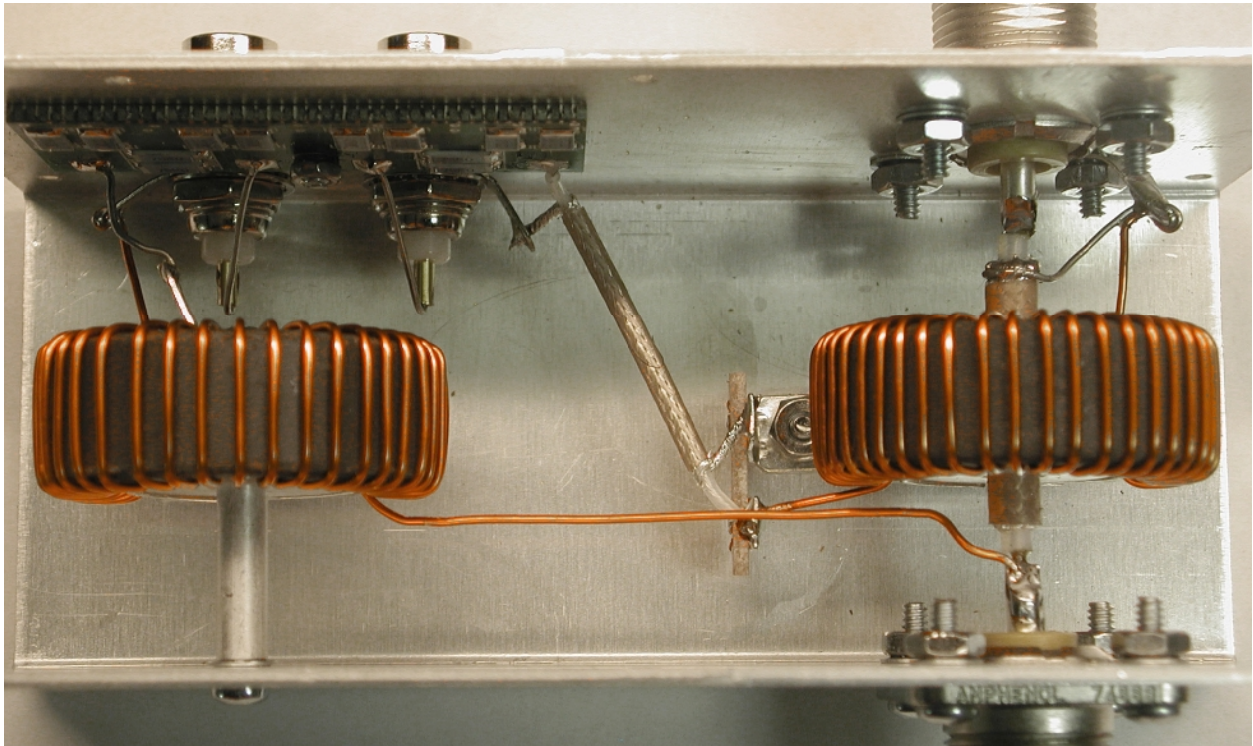

Refer to the drawing and pictures during assembly of the coupler. The top picture is courtesy of Dario, N5QVF, and the lower right one is courtesy of Stan, W5EWA. The sequence of pictures below is from Jack K8ZOA. Jack developed a clever way to ensure proper winding of the cores, both for spacing and coverage of the windings. Details of Jack's winding methodology is found below.

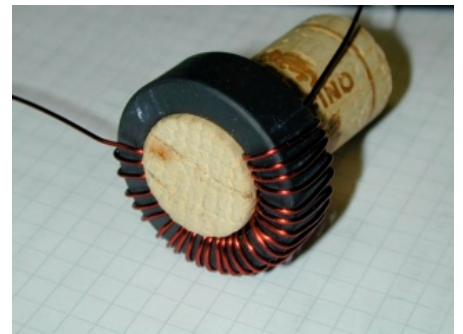



# Assembly cont'd

Construction of the coupler consists of only a few steps. The main components are the transmission line, toroidal transformers and the attenuator PCB. The most critical step is the winding of the transformers. They are wound with 26 turns each of #20 enameled wire. The cores are wound in opposite directions, i.e. they should be mirror images of each other. The windings should be evenly spaced over ~60% of the core, as shown later. The cores are supported by nylon bushings with Teflon tape over them, which are inserted into the core centers after winding. If the wires are wound tightly, the cores should fit snugly, but should not have to be forced. The cores should be wound by hand, don't use any tools on the cores or wires as they may break.

Here are some details of the winding aid that Jack, K8ZOA developed. He created the rule using Excel, using the following method.

Start with a fresh Excel workbook. Click on the upper left cell, and select underline. Right click and select copy, then highlight cells 2 thru 25 in row 1, right click and select paste. You should now have a stack of 25 lines in row 1. Adjust row height for 0.10" (2.54mm) between lines, which corresponds to a row height of 7.2. Do this by highlighting the 25 rows, select Format > Row > Height in the toolbar, and set row height to 7.2. This gives 60% coverage which matches the small Teflon tape size gap. Copy the cells and paste extra copies so that you will have at least two to use after printing.

The reduced size screen capture to the right shows what the screen should look like before printing. Print the screen, cut to the rules out and tape to the cores. Use a white laundry marker or grease pencil to mark the lines on the toroids. Jack recommends the use of a tight fitting cork to hold the windings in place as you proceed, and to help flatten the wire against the core on the inside.

The bushing with the larger hole is mounted between the SO-239 connectors, and supported by the RG-142 Teflon® coax. This piece of coax forms the primary winding of the current sampling transformer. The other transformer is supported by a 0.625" (1.59cm) standoff and 1.0" (2.54cm) screw which forms the primary of the voltage sampling transformer. One end of this standoff is grounded, and the other connects to the attenuator PCB. The transformer secondaries are wired as shown in the drawing. It is important that the cores be positioned as shown, and the wires be routed as shown. Improper routing or core orientation will affect performance, especially above 25 MHz.

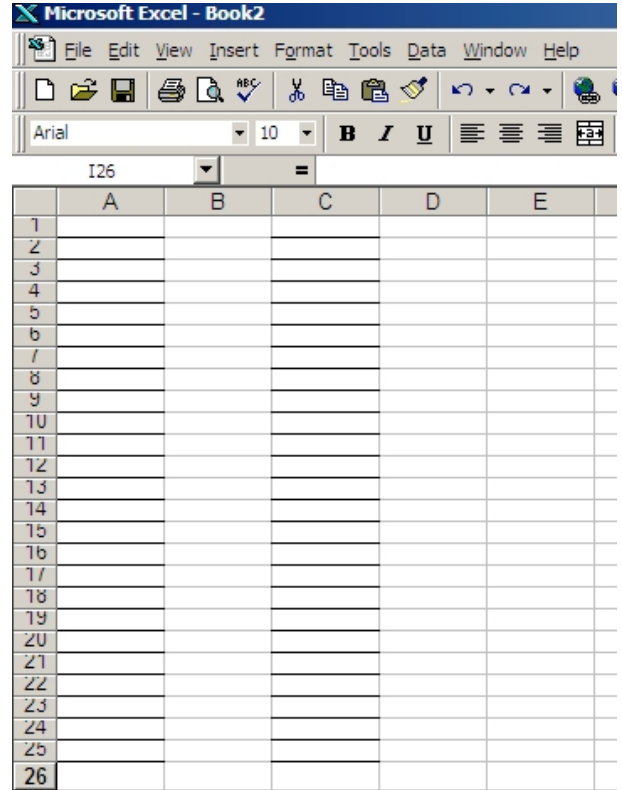

- q Install the two SO-239 UHF connectors using 4-40 x 3/8" (9.53mm) machine screws, #4 lockwashers and large #4 hex nuts for 7 of the mounting holes. The remaining hole, uses 4-40 x 3/8" (9.53mm) hardware and a solder lug as shown. The solder cups on the SO-239s should be facing upward.
- q Solder two short pigtails about 1.5" (3.81cm) long into the center pin of the two BNCs. You can use cut ends from other parts for this. Install the two BNC connectors using the supplied special hardware, including solder lugs, as shown.

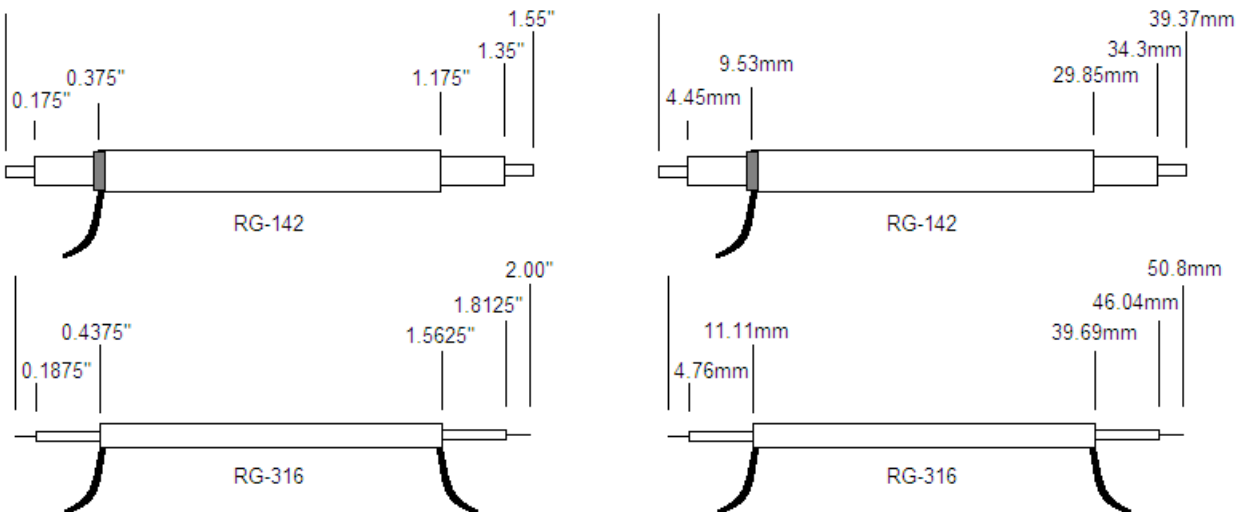

## Assembly cont'd

- q Prepare the two pieces of coax as shown in the diagram. Make sure that the shield wires don't short out to the center conductor on either end. RG-142 is double silver shielded. Leave a little shield showing on one end as shown in the pics above, and then wrap a short pigtail of wire around it. It is safe to apply a reasonable amount of heat to the Teflon coax without worry about melting the insulation.
- q Wind 26 turns of #20 enameled wire on each of the FT140-61 cores.. The cores will be wound in opposite directions, so that the finished toroids will be mirror images of each other. A winding is defined as the wire passing through the center of the core. If you count windings on the outside edge of the core, your count will be one short of the actual number of turns. Mis-counting by one turn will give you a power reading error of 8%, and cause other problems as well. The current sampling xfmr is installed between the SO-239 connectors, and will be supported by the short piece of Teflon® coax. The voltage sampling xfmr is supported by the long standoff. Leave 1" (2.54cm) long pigtails on the xfmrs except for the lead that exits from the back of the voltage xfmr (lower right lead in the lower right picture below), which should be 3" (7.62cm) long (shown exiting the frame in the picture). Scrape the enamel off the ends of the short leads. A razor knife or sandpaper is good for this. Note: It is best to scrape the enamel off, as the supplied wire may or may not be heat strippable. Wind the wire tightly. Use your fingers to keep the windings formed close to the cores on the inside.

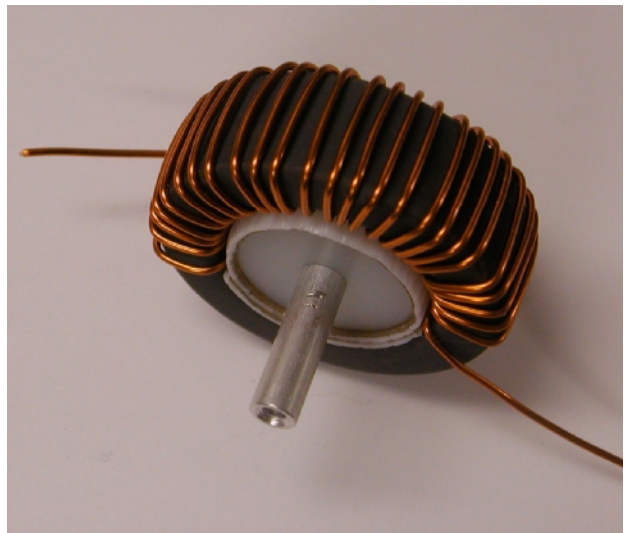
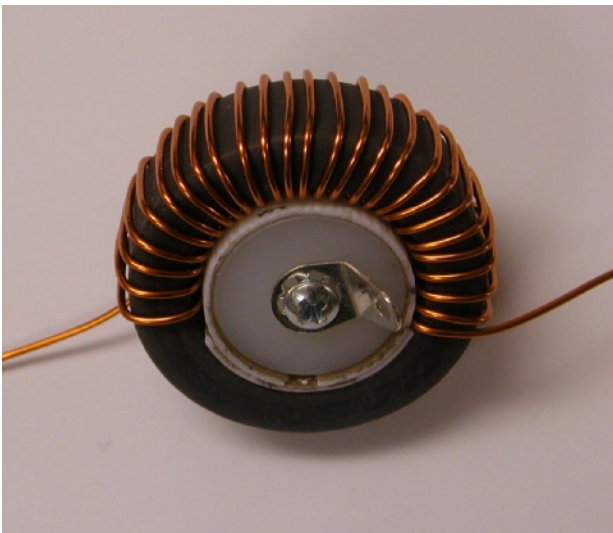

- q Before slipping the nylon bushings into the wound cores, take the two long pieces of Teflon® tape, peel the paper off of the adhesive side, and wrap each of the nylon bushings with the Teflon® tape. Then take the short pieces, remove the paper, and stick them in the cores between the windings. This will make for a tight fit inside the toroid cores, and will also serve to keep the windings properly positioned around the cores. Before sliding the cores in place, make sure that the inside of the windings is flat against the cores. Be careful when pushing the cores in place not to dislodge the Teflon® tape. See the picture below. Note: The picture shows the voltage xfmr with the older bushing with 1/4" (6.35mm) hole. The latest version is 1/8" (3.18mm). The old picture also shows a slightly different mix of Teflon® tape.

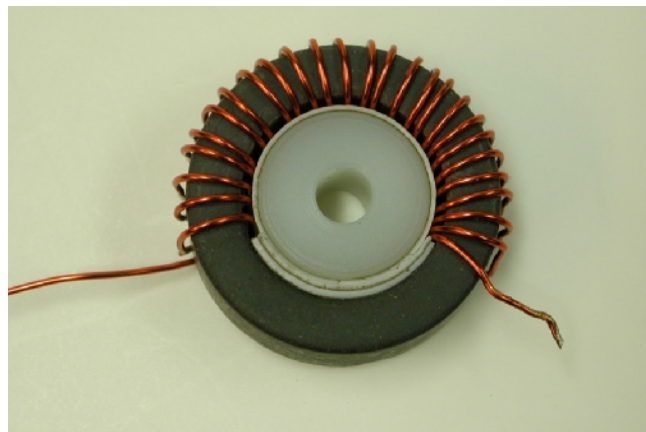

# Assembly cont'd

q Solder the 12 SMT resistors onto the attenuator board as shown. Don't be afraid of these parts. These are VERY big parts as SMT goes. The resistor values are printed on the resistors. Use a fine tip on the soldering iron, and tin ONE of the PCB pads for each resistor with a small amount of solder before attempting to solder the resistors. Hold the resistors in place with a tweezers, and apply a little heat to the edge between each pad and the board until the solder flows between the resistor and pad. It is helpful to slide the resistor over the pad as it melts onto the solder drop, so that the other end exposes a little of the pad on the other side. Solder the other side in place by applying heat and solder to the edge where the resistor sits on the pad. Then go back to the tacked pad and touch up if necessary. Applying a little flux to the board ahead of time will help to hold the parts in place and aid in solder flow. To verify the proper installation of the resistors, use an ohmmeter to check the resistance of each bare stripline connection to ground. The mounting hole is grounded, as well as the long strip along the top edge. Each point should be about 83 to 84 ohms. If not, check your soldering.

q Install the PCB onto the side of the coupler above the BNCs as shown. The board mounts with the hole near the bottom edge. Bend and solder the pigtailed from the BNCs to the two striplines near the mounting hole. Use 4-40 x 1/4" (6.35mm) machine screw, the small split lockwasher and small hex nut to mount the board.

q Solder one the short piece of RG-316U prepared earlier to the solder terminal on the bottom of the coupler, with the coax shield connecting to the grounded lug, and the center to the lug that connects to the current sampling xfmr.

q Solder the center conductor from the other end of the coax to the remaining PCB stripline pad, and the shield to the ground lug on the center-most BNC.

q Slide the current sampling transformer over the short piece of RG-142 as shown in the diagrams, being careful to position the windings and the coax shield as shown. This is a tight fit, but if you take your time and rotate the coax as you press it into place, you shouldn't have any trouble. There seems to be a little variation in the diameter of the RG-142, so you may find that you need to file the inside of the bushing a little to allow a good fit. This can be done with a small rat tail file, a rolled piece of sandpaper or a reamer. An alternative, suggested by K8SIX is to use a #10 drill bit to drill the hole out a little.

q The xfmr should be oriented level, with the windings facing up before soldering. Solder the coax on the shield end into the SO-239 connector, and the shield wire to the solder lug on the XMTR connector. Cut the wire from the outside left of the transformer secondary to length and solder it to the lug on the XMTR connector. The other end of the coax will be soldered along with the long wire from the voltage xfmr in an upcoming step.

q Install the 2-lug terminal strip, then cut and solder the wire coming from the inside right side of the xfmr to the insulated lug on the terminal strip.

q Prepare the voltage xfmr as shown in the photos on the bottom of page 13, using the 0.625" (1.59cm) standoff, 4-40 x 0.75" (1.91cm) screw, lockwasher and solder lug. The long lead should exit the core on the side with the standoff as shown in the overhead picture of the coupler. After approx. serial #350, a lockwasher was added between the standoff and nylon bushing.

q Bend the solder lug out at close to a 90 degree angle, and solder a small length of discarded component lead to it.

q Attach the assembly to the side of the coupler using 4-40 x 3/8" (9.53mm) hardware. The solder lug and pigtail should be facing the PCB. It is important that this assembly be attached firmly or you will see erratic operation. A lockwasher should be placed between the coupler wall and standoff, and one between the screw head and outside of the coupler.

q Prepare and solder the short end of the toroid winding so that it connects to the solder lug on the right-most BNC. If the core is mounted correctly, this wire should come off the right side of the core from the inside. Solder the pigtail from the standoff to the stripline pad on the end of the PCB. Leave a small bend in this lead to allow for flexing when the top is attached to the coupler and the walls are pulled apart.

q The long wire coming off the outside left side of the core goes to the output SO-239 as shown. The end of the wire should be placed inside the SO-239 center connector alongside the RG-142 center conductor, or looped around the SO-239 center conductor as shown in the photos. Be sure to scrape the end to allow good soldering in either case. Before soldering these wires to the SO-239, the walls of the coupler need to be pre-tensioned so that there won't be any stress on the RG-142 when the top is attached to the coupler. To do this, I use a 2" (5.08cm) long standoff placed between the walls above the xfmr to separate the walls slightly. A suitable substitute would be a 2" (5.08cm) long piece of wood dowel. The wire should be routed about 1/8" (3.18mm) from the current xfmr as shown. For best phase accuracy at 50 MHz, a little coupling to the current xfmr secondary is desirable. Remove the spacer.

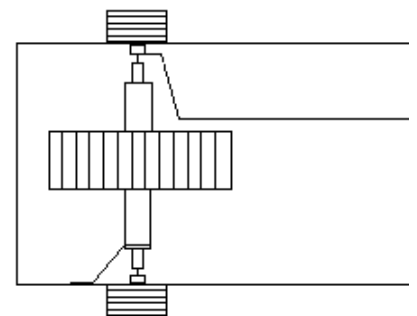
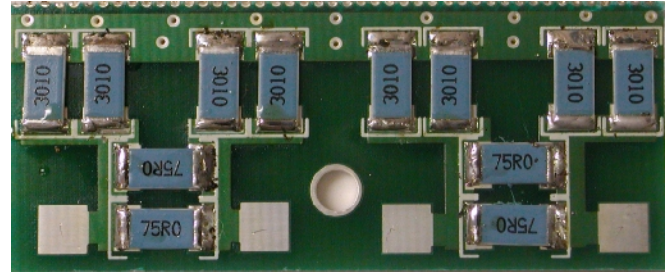



# Assembly cont'd

- q Make sure that all connections are soldered well, and that the cores are level. Slip the top on and attach with (14) 4-40 x 1/4" (6.35mm) sheet metal screws. Apply pressure the ends of the cover to prevent gaps from forming as the screws are tightened.
- q Clean and wipe the top of the coupler. Carefully line up the top label and apply starting at one end and smoothing as you go to prevent the formation of bubbles.

## Final Checkout and Assembly

Before going through the Setup screens, it is necessary to verify that the remaining basic circuits are working. Power up the LP-100, and verify that the current draw is correct. (160 mA). Connect the Current and Voltage ports of the controller and coupler together using the supplied 6' (1.83m) coax cables. You may want to bundle the cables using electrical tape to make for a neater installation. One cable should be marked with colored tape at both ends so that the cables are always connected consistently in the future. I also mark the Current jacks on both ends so that the colored cable always connects to Current. This prevents crossing of the cables, and also eliminates errors due to cable variations.

Connect a 50 ohm dummy load to the LOAD port. Select the Fast mode for the display (press Fast/Slow button until you see a lower case "w" after the power value), and apply a small amount of power. The Power and SWR bargraphs should deflect upward, and the numerical readouts should display a number very close to the expected value. Switch to the vector display (press Mode button once), and you should see values close to 50 ohms for Z and R, and close to zero for phase.

Next, enter Setup mode as described in Initial Setup, and scroll to the Gain/Phase Zero screen. Advance to the Gain/Phase Zero screen by pressing Mode twice. You should see the band indicated in the lower left corner during transmission. This should match the band you are transmitting on. The Band indicator should remain on the last used band after transmission.

Using the Alarm Set button, set the Alarm for "1.5". Remove the dummy load and transmit into the coupler at low power. The Red Alarm LED should light on the front panel, and the relay should click. If you have JP1 in place, the Piezo transducer should also sound. Note: the transducer will sound pretty loud since it's not inside a case at this point. Reconnecting the dummy load will cancel the alarm after a second or so. You can double-check the PTT connections with an ohmmeter at this time. The center conductors of the RCA connectors would be normally shorted together, and open when the alarm sounds.

You are now ready to install the controller board in the case. First, loosely install the 4-40 x 1/4" (6.35mm) threaded standoffs on the bottom of the case using 4-40 x 1/4" (6.35mm) black machine screws. Next, slide the board into the rear holes as you drop the front down toward the bottom. Be careful not to scrape the bottom of the board on the front panel as you slide it.

Once the board is in place, align the front holes with the switches and LEDs, and screw the board down with four more 4-40 x 1/4" (6.35mm) black screws. Tighten the bottom screws. The switch caps will be installed after calibration, in case a problem shows up that requires removal of the board from the case. The caps can be scratched during removal if they are installed.

Install the four remaining 4-40 x 1/4" (6.35mm) standoffs on the front of the PLED PCB, using four 4-40 x 1/4" (6.35mm) black machine screws, and tighten. Mount the PLED PCB to the front using the remaining black machine screws, and install the ribbon cable between the two PCBs as shown in the picture. **Don't forget to remove the protective film from the PLED display surface before mounting.** Again, make sure that the ribbon jack lines up properly with the header pins. The top cover will be installed after calibration.





## Connections...

Power: 11-15 VDC, center pin +, 2.5mm. The lead with the white stripe on the supplied cable is +  
PTT: Loop the PTT between your amplifier and rig through the LP-100 using RCA connectors  
RS-232: Connects to computer... standard M-F straight through DB9 serial cable.  
Current/Voltage: Connect to corresponding jacks on the coupler using supplied RG-58U cables.



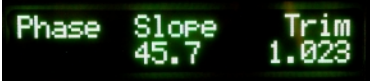

# Setup/Calibration

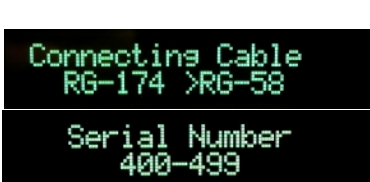
Note: This section assumes you are using firmware version 1.1.1 or later, and of course the upgrade PIC processor. If you own a kit from the first production run (serial # 100 or older), then it is highly recommended that you upgrade to the new processor before calibration to avoid having to calibrate twice. This is a no charge upgrade (except for shipping cost).

Enter the Setup mode again as described in Initial Checkout. Below you will see a picture of each Setup screen along with a brief synopsis of what it does and what the controls adjust. Remember, for firmware 1.1.45 or later, it is a single, long, Mode button press.

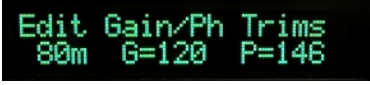
	<p>Reference screen. Displays the reference voltage from the gain/phase detector, as well as the RSSI voltage (Received Signal Strength Indicator) from the AGC chip used in the frequency counter preamp. This voltage is proportional to the log of the RF input power to the LP-100. The screen also shows temperature in Deg F &amp; C. There are no adjustments for this screen.</p>
	<p>This screen allows you to enter the actual impedance of your dummy load. This will result in a more accurate calibration if your dummy load is other than exactly 50.0 ohms.</p>
	<p>This adjustment is used to calibrate the zero point (or offset) of the magnitude and phase detectors. The adjustment is semi-automatic in that you don't have to make any adjustments. The process requires you to briefly transmit into an accurate 50 ohm dummy load on each band in sequence, and to press the Alarm/Dn button to save the correction for each band.</p>
	<p>This adjustment is used to calibrate the slope of the phase detector. It is simply done by inserting a line with known delay into the Current input of the LP-100, and transmitting into a high quality 50 ohm dummy load. The controls are then adjusted so that the display correctly shows the line delay. If coax of known Velocity Factor is used, the line length in degrees can be simply calculated.</p>
	<p>This adjustment is used to calibrate the slope of the gain detector. It is accomplished by transmitting into a 25 ohm load and setting the Trim for a reading of 25.0 (or whatever the actual load resistance is if it's not exactly 25.0).</p>
	<p>Allows adjustment of the accuracy of the op-amp detector and ADC to provide correct conversion values at low power levels. The screen shows the output voltage of the detector, and the Trim level is set by adjusting for zero voltage with no RF power applied.</p>
	<p>Adjusts overall power accuracy of the LP-100. This adjustment affects all frequencies equally, and is made by comparing the LP-100 power reading with an accurate reference. Acceptable reference measurement devices can be inexpensively made, and will be described later.</p>
	<p>Same as above, but adjusts the displayed power reading on a band-by-band basis. The built-in frequency counter detects the band you're on, and stores the CAL constant for each band automatically for 12 bands from 160m through 4m. The counter works from 50 mW to 2500W.</p>
	<p>This screen is used to match the readings of the low power and high power ADC inputs. It is done at a power level below 320W, which is the point at which the low power input reaches maximum. Its purpose is to allow compensating for any error in the 1% precision divider parts used in the high power input. <b>NOTE: Moved up between Offset and Master on ver. 1.1.47c and later.</b></p>
	<p>This screen allows setting the SWR Alarm power threshold and Power display type. The alarm threshold is used mainly in contesting stations with multiple transmitters to prevent false alarms when energy from another transmitter is picked up by an antenna. The choices are 0,0.1, 1.0, 10.0 and 100.0 W. The power</p>
	<p>This screen allows selection of the correct cable compensating table to match the connecting cables you are using. Early LP-100s used RG-174U, but a change was made to RG-58U starting with serial # 101. Starting with serial #400, this menu was changed to a serial number selection, and covers any hardware change between versions instead of just cables. In the case of the 5<sup>th</sup> run, it covers the change in response of a slightly different model power combiner.</p>

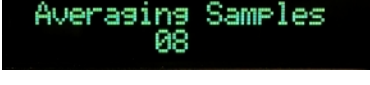
# Setup/Calibration Cont'd

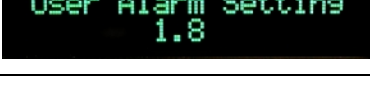
	<p>Allows editing of the Gain/Phase Zero CAL values, which are normally gathered automatically. This is useful for restoring accidentally changed values. The Dn button adjusts gain trim, and the Up button adjusts phase trim.</p>
	<p>Allows setting of maximum bargraph scale values for all three autoranging scales. The Dn button selects Low, Mid or High range, and the Up button allows scrolling through the various max power options. The displayed range includes 0.4dB overshoot (~10%) above the indicated value. Note: These ranges do not affect the numerical readout, which has no limits. Defaults are 15W, 100W, and 1500W.</p>
	<p>This screen is used to set the width of the bargraph in the Fast mode. It is useful for optimizing the bargraph resolution for amplifier tuning, for instance. The displayed range goes from the maximum set in the previous screen, to a minimum which is the selected number of dB below that maximum. Default is 6dB. The name of this screen was changed to Fast Bargraph Range.</p>
	<p>This screen allows setting of the number of samples used to average the numerical readout in Fast mode. The range is 2 to 32 samples. The default is 8 samples.</p>
	<p>This screen allows setting the peak hold time in the Slow (peak) mode. The range is 0.25 to 5 seconds. The default of 3 seconds is good for normal SSB or CW operation. The fastest setting can be useful for amplifier tuning, especially when a "pulser" is used.</p>
	<p>This screen is used to set the "User" SWR Alarm setpoint. It can be set between 1.0 and 5.0 in steps of 0.1.</p>

## Impedance Calibration

Calibration is done in a couple of steps. First the impedance measurement system is calibrated, and then power level is calibrated. The required tools for this calibration are a high quality 50 ohm dummy load, a high quality power meter or other method of determining power as described in the text and a short coaxial line of known electrical length. A second dummy load is also desirable for calibrating the slope of the gain detector for impedance, but not absolutely necessary as this adjustment seems to vary only slightly from meter to meter. I normally do calibration at 100W, but very close to full accuracy can be had with power as low as 5W, and somewhat reduced accuracy is attainable down to <1W.

I am working on a "calibrator" design which would use inexpensive 1% thick film resistors or 5% metal oxide resistors to provide switchable 50/25 ohm impedance with a 10W rating. It would include a diode peak detector for measuring power with a calibrated table of voltage vs. power. I am also testing a method of using a 6' long length of RG-59U which, when terminated with a 50 ohm dummy load, produces a known complex impedance. This provides a more accurate way of setting the Gain and Phase slope adjustments, and takes into account coupler variations as opposed to the delay line method. I have characterized readily available and inexpensive cables available from Jameco, Radio Shack and Mouser, and will provide part numbers. The cables are BNC-to-BNC, and may require UHF adapters if you don't already have them. These are also available from the above suppliers.

The first calibration screen is the "Dummy Load Z" screen, which allows for the entry of your dummy load's actual impedance. This makes calibration more accurate when your load is not exactly 50 ohms. Use the Dn/Up buttons to set the display to match your load's actual impedance. If you don't have a good way to measure your dummy load, you can measure the resistance at DC using a DMM. If you know the load to be low-inductance through 6m, this will give a reasonable approximation. If you are looking for a high quality dummy load, check out [www.ridgeequipment.com](http://www.ridgeequipment.com). They have some excellent surplus loads for as little as \$10.

The next screen is the Gain/Phase Zero screen. This allows for band-by-band balancing of the gain and phase detectors. To do this, connect your dummy load to the ANT connector on the LP-100 coupler. Starting with the lowest band you can transmit on, key the transmitter. Press the Alarm/Dn button to calculate and save the correction data, then unkey the transmitter. You should see the Trim values change on the display. Do this in order for all the bands. (The Fast/Slow/Up button resets the trim values for the displayed band to the default value of 127, and the Edit Gain/Ph Trims screen allows editing these values after capturing if needed).

The next adjustment screen is Phase Slope. This adjustment sets the slope of the transfer curve of the phase detector so that the measurement limits are correct. The above Zero adjustment ensures that zero degrees reads close to zero. This adjustment ensures that higher phase delays display accurately. Together they define the slope of the phase detection curve.

# Setup/Calibration Cont'd

As mentioned in the Overview, adjusting the Phase Slope is simply a matter of matching the reading to a known delay line value. Again, the formula for determining delay in degrees is...

$$\text{Phase Delay (Degrees)} = (360 * L * F) / (984 * VF)$$

Where L is in feet and F in MHz. VF would generally be 0.66 for polyethylene dielectric. Foam dielectrics are generally have a VF of about .80. Check for the correct value of the coax type/brand you are using. A 6' length with poly dielectric will provide a delay of near 45 degrees at 14 MHz. This is a good range to use, as it places the phase display at about midrange.

Insert the delay line into the Current cable between the controller and coupler, using a BNC barrel connector. With a 50 ohm load, the phase should read close to the calculated value in degrees. If not, use the Dn/Up buttons to adjust the reading to the correct value. Leaving this setting at the default 1.000 will result in a maximum phase error of a few degrees over most of the frequency range.

The last impedance adjustment screen is called Gain Slope. This sets the slope of the gain detector so that it is linear with increasing Z. The adjustment requires a load other than 50 ohms, A convenient value is 25 ohms, which can be created easily by paralleling two 50 ohm loads using a "T" connector. It is important when making this adjustment that there is no coax between the 25 ohm load and the coupler "Load" connector, otherwise the line will transform the 25 ohm resistive load to some mixed R+jX value. The easiest way to do this is to screw a UHF Tee connector directly to the Load connector, and then use adapters or lengths of 50 ohm coax to connect to the two 50 ohm loads. With the transmitter set to 20m, apply power and see what the impedance reads on this screen. If the displayed value is slightly higher or lower than the actual value, adjust the Dn/Up buttons to match the load's actual Z (or resistance on a DMM). If a 25 ohm load reads 100 ohms, you have the current and voltage cables crossed. Correct this and start calibration over from the top. Remember to return to a 50 ohm load after this test. The expected trim value should be in the range -.0004 to +.0004, and will usually be even closer than that. Leaving this adjustment at 0.0000 will result in a maximum error of a few tenths of an ohm.

## Power Calibration

Before starting calibration, it should be pointed out that calibration is not absolutely necessary. In calibrating hundreds of the assembled versions of the LP-100, it was found that the maximum error, as read on a HP-436A power meter, was +/- 1.5% before calibration on 160-10m. The error on 6m can be more like +/- 5-10% before calibration. Of course, there is more consistency in coupler construction on the assembled units than there would be with dozens of different builders, but it would be unlikely that the error would be more than about 5% if care is taken to follow the instructions on the coupler assembly.

The first test requires no test equipment. While in the Setup > Offset screen, adjust the Dn/Up buttons for a zero reading of the displayed voltage with no RF power applied. This nulls out the residual offset voltage of the op-amp detector.

The next screen allows for the adjustment of Master power sensitivity. This value will normally be near 1. Both the Master and Fine power adjustments have a range of +/- 12.5% in 0.1% increments.

The Fine sensitivity adjustment is made while transmitting into the LP-100. The adjustments affect the trim values for the band being displayed. The frequency display follows the transmit frequency automatically when you transmit.

Before adjusting either the Mstr or Fine trims, it is necessary to provide an accurate means of measuring power that is independent of the LP-100. The simplest approach to this is to borrow a high quality meter like a Bird or Alpha to use as a reference, and connect it between the LP-100 and dummy load with a UHF male-male adapter. An even better approach, which is what is used for the factory calibration, uses a calibrated 30 dB attenuator feeding a laboratory power meter (HP436A or Boonton 4200 in my case). The power meter is calibrated against an NIST (National Institute of Standards and Technology) traceable reference calibration signal.

The most accurate simple method for doing this with common tools is to use a high quality dummy load with a diode peak voltage detector and DMM. Here is the setup...

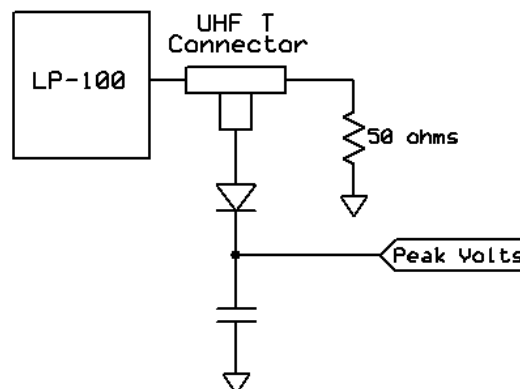

# Setup/Calibration Cont'd

The following formula can be used to determine power.

$$P \text{ (watts)} = (V_{pk} + .25) * (V_{pk} + .25) / 100$$

The diode is a 1N5711 Schottky diode, and the cap is .01uF. A convenient power level to use is 10W, as it is within the PIV specs of the 1N5711. 10W produces a peak voltage of ~31 V across a 50 ohm load. The diode will handle up to 40W, but I have only tested the circuit for accuracy at 10W. The voltage needs to be measured by a high impedance DMM with good accuracy. Most quality DMMs have > 1 meg input impedance, and many have > 10 meg input impedance.

The accuracy of this setup will mainly be related to the quality of the load. If the dummy load error is 5%, then the power calculation will be roughly 5% off. You can roughly guess at the RF resistance of your dummy load by measuring it at DC with a DMM, although that method will most likely be inaccurate at 50 MHz, and probably at 28 MHz as well. Make sure you measure the resistance with the load at operating temperature. Also, all connecting cables / adapters need to be as short as possible. If you are unsure of the quality of your dummy load, I recommend visiting [www.ridgeequipment.com](http://www.ridgeequipment.com) to look at some of their offerings. These are high quality loads, and for a small fee they will supply you with a calibration table and chart of the return loss of the load.

The actual diode drop will very likely be within about .2V of the assumed value in the formula, for a voltage error of under 2%. If you don't have access to these methods, you can send your completed LP-100 back to me for calibration if you are willing to pay for return shipping costs.

Before doing the power calibration, make sure that you have the correct style of connecting cables selected in the Connecting Cable screen. The choices are RG-174 and RG-58. Early serial numbers used RG-174, but later models switched to RG-58. The Connecting Cable screen allows you to select the cable type that matches your meter, which then sets the correct cable compensation table for that cable. Note: This screen has been changed to one where you select the serial number range of your meter. This allows compensation for other small hardware factors that may change from run to run as well.

The first step in power calibration is to set the Master Trim value. This should be done on 3.5 or 7.0 MHz. Make sure the Fine Trim setting for this band is 1.000, then transmit at a known power level and adjust the Master Trim for the correct power reading. The Mstr setting will not be touched after this.

To adjust the Fine power constants for each band, simply transmit on the band of interest and adjust the Dn/Up buttons for the correct power readings. Move through all bands in sequence until they have all been adjusted. You will notice that when you transmit now, the band indicator shows the band you are transmitting on and the Trim value changes automatically based on the band.

The Mstr Trim setting will typically be within 2% , and the variation of Fine Trim setting should be < 1% from 160-20m, <2% through 10m and <10% on 6m. This is dependent on a number of factors to do with xfmr winding, positioning and wire routing, and so will vary from builder to builder... BUT the calibration routine will eliminate any variances. Setting the trims to the following values will typically result in better than 5% accuracy without calibration through 10m...

Mstr – 1.000	160-80m – 1.000	60-30m – 0.998	20m – 0.995	17/12m – 0.993	10m – 0.990
--------------	-----------------	----------------	-------------	----------------	-------------

6m can be left at 1.000, but it can be as much as 10% off without specific calibration.

The last screen to adjust is the Hi/Lo screen. This is used to match the power readings for the high and low power ranges. If you transmit at a power of 100W, the two readings should roughly match. If not, adjust the Dn/Up buttons to match the readings. The Hi reading has less resolution, so it will jump around a little and you may not get an exact match. If that's the case, err on the high side.

Log all your constants for future reference, and you're done. There is a page at the end of this manual to make that easy. **NOTE:** Normal use of the LP-100, including the flash programming of a new firmware version, will not disturb the saved CAL constants unless you have the MCLoader software set to "Program Data". Jotting the values down will allow you to return to your original settings in case you accidentally change a value by mistake. I am planning a Windows utility to allow saving, editing and restoring of the CAL table.

## Final details

If everything has checked out to this point, you can complete the assembly of the controller by adjusting the LEDs on the front panel to line up with the holes, and snap the switch caps in place on the switches. You can also attach the rear panel to the RCA connectors using the 4-40 x 3/8" (9.53mm) self-tapping screw provided. Don't overtighten. You can now install the cover on the controller using the 4-40 x 1/4" (6.35mm) self-tapping screws provided. **NOTE: Do not accidentally use the longer 3/8" (9.53mm) screw at the case location near the PLED display connector. It is imperative that this screw not be longer than 1/4" (6.35mm) or it will short out the connector.**

If you wish to add a power switch to the LP-100, you can do so at this time. I provided a 2-pin header to wire the switch to using a plug. In this way, the LP-100 PCB can be removed in the future by unplugging the switch.



# Operation



Operation of the LP-100 is straightforward, and designed to require a minimum of input once set up and calibrated. There are only three buttons which are used in combination to access all the menus on the LP-100. There are five main modes for the LP-100, which are accessed by momentarily pressing the "Mode" button. Pressing the button in mode 4 returns you to mode 1. The mode status is saved in non-volatile memory, and the LP-100 will return to the saved mode upon powering up. There is also an automatic two-step screen saver mode which dims the screen after approx. 30 sec of inactivity, and marches your call sign across the screen after approx. 2 min. of inactivity. This is done to extend the life of the PLED display.

## Mode

There are five selectable modes... Normal, Vector, dBm, Field Strength and Compression. A sixth mode which display relative power and phase between phased array elements or stacked beams is in the works as well.

*Normal* mode is designed to display all the information you normally need on one screen. It displays power in three auto-ranging scales, and SWR, plus bar graphs for both.

*Vector* mode displays Z, Phase angle of Z, X and R. These values are relative to the "LOAD" connector, not the antenna. Antenna Z can be calculated by knowing the feedline length and using a program like TLW, or a Smith Chart. Note: The LP-100 cannot determine the sign of X automatically.

*dBm* mode uses professional dBm and RL (Return Loss) instead of watts and SWR to indicate power and load quality. The resolution is 0.1 dB for both. The range is +15 dBm to +64 dBm, and RL from 0 to 49.9 dB.

*Direct/Field Strength* mode is similar to dBm mode except that it is calibrated to display power from -15 dBm to +33 dBm. There is no return loss in this mode because it does not utilize the coupler. Power is supplied directly to one of the inputs on the back of the LP-100. This mode can be used for accurate low power bench measurements, as in checking the output to a transverter or the level of a local oscillator or mixer. It is also very useful for doing antenna field strength measurements, as in checking a beam pattern. This requires feeding a small pickup antenna to one of the inputs. The LP-100 could be set up in a field, connected to a laptop computer with wi-fi, and the results can be read over the wireless LAN back in the shack. This eliminates any wiring that could distort the pattern. **NOTE: The maximum power for the direct inputs is 1W continuous.**

*Comp* is a recent feature still under development. It displays peak and average power, and a dB ratio of peak/average. This can be useful for determining "talk power" and can be helpful in setting a compressor/clipper, or comparing such circuits. I am working on a better algorithm for the average reading that will be more stable. This feature will be operational in a future release of the firmware. All firmware and software upgrades for the LP-100 will be available for download from my website. The firmware upgrades can be easily flash programmed through the serial port with the supplied software.

## Alarm

The Alarm button is used to set the SWR alarm set point. There are 6 choices... OFF, 1.5, 2.0, 2.5, 3.0 & User. The User setting is adjusted in Setup/CAL mode. Holding the Alarm button will advance the choices every half second or so. Tapping the button will put the Alarm in "snooze" mode for a minute. Tapping again during tuning will extend the function another minute. This allows adjusting an antenna tuner without the alarm going off, but it returns to normal after tuning to protect the amplifier as intended.

# Operation cont'd

## Fast/Slow

This button toggles between a fast responding numerical display, a peak-hold display and starting with firmware version 1.1.47, a tune mode. In all cases, the bar graphs remain in fast mode. The character after the numerical power readout indicates which mode you are in. A "W" indicates peak mode, a "w" indicates fast mode and a "T" indicates tune mode. Fast mode is best for taking accurate measurements with steady state signals, or for tuning an antenna tuner. Slow (peak) is best for CW or SSB operating. Note: The Peak Mode is VERY fast, and can respond to a lip smack, mic button click, etc. Don't be alarmed by this... it is normal, and allows the LP-100 to provide an accurate indication of peak power. Unless a lot of compression is used, the peak reading will be somewhat higher than the indication with a carrier... as much as 30% depending on the ALC attack time in your rig, and power supply regulation of rig or amplifier. Tune mode is similar to Slow mode, except that the peak hold time constant is set to 0.25 sec. The Fast and Tune modes use the preset bargraph range in the setup section, while the Slow mode shows a fixed 13 dB range. The Tune mode locks the bargraph in high power range.

## Setup

**NOTE: The screens and ordering of the screens vary slightly from version to version of the firmware. These descriptions are based on firmware version 1.1.47b or newer.**

The calibration modes can be accessed through this menu. To enter Setup mode, press Mode and Alarm in quick succession with a little overlap. This sounds tricky, but it's easy to master. . **NOTE: Starting with firmware version 1.1.44, entering (or exiting) Setup is accomplished by holding the Mode button for about a second until the screen changes.** Once in Setup mode, the Mode button is used to cycle through the calibration modes. There are 8 setup screens...

*Reference.* This screen display the reference voltage from the gain/phase detector, the RSSI output from the counter AGC amplifier and temperature in degrees F & C. It is only mainly for diagnostics. Pressing the Alarm button in this mode resets the PIC, quite useful when flash programming the PIC. Pressing the Fast/Slow button toggles the Temp display between degrees C and F.

*Dummy Load Z.* This allows you to enter the actual Z of your dummy load before calibrating. Most dummy loads are not exactly 50.0 ohms, and this will improve the accuracy of your calibration by providing the correct reference.

*Gain/Phase Zero.* This screen allows band-by-band calibration of the balance of the gain and phase detectors. The process simply requires a short transmission on each band into a dummy load, and the pressing of the Alarm/Dn button (which acts as a Save button on this screen). The Fast/Slow/Up button becomes a Reset button in this mode, clearing the currently set corrections for the indicated band. The LP-100 automatically gathers the correction factor and saves it indexed to frequency. The built-in frequency counter automatically determines the frequency.

*Phase Slope.* Allows calibrating the phase detector. This requires a delay line of known value. In its simplest form, this can be done by calculating the electrical length of an existing piece of coax in the 3-10' range, and matching the readout to the calculated length at the frequency used for the calculation. More on this in the Calibration section. I am also working on a calibrator kit to simplify this.

*Gain Slope.* Allows setting the slope of the magnitude for proper Z at a value removed from 50 ohms. This can be done with any reasonable known load in the 25 or 75-100 ohm range. I am also working on a calibrator kit to simplify this.

*Offset.* Provides for calibrating the low level ADC converter accuracy. The screen shows the output voltage of the detector, and the Trim level is set by adjusting for zero voltage with no RF power applied.

*Hi/Lo.* This screen allows the matching of the direct and divided inputs to the ADC to account for any slight variations in the precision divider. **NOTE: This menu moved up to this position starting with version 1.1.47.**

*Master.* Adjusts the overall gain for power readout for all frequencies.

*Fine.* Adjusts gain by band for power readout, indexed by frequency. Frequency is determined automatically by a built-in frequency counter.

*AL Thresh/Pwr Mode.* Allows selection of a power threshold for the SWR alarm. The normal setting is zero, meaning that the alarm will work at any power level. Values of 0, 0.1, 1.0, 10.0, 100.0W. This is useful for multi-transmitter contest setups where significant energy from a nearby antenna might be present on the output of the LP-100 coupler. If the energy is from another band, the LP-100 will display SWR, which will be high. By setting a power threshold for the alarm, it will keep the alarm from tripping on induced power. The Pwr Mode allows selection of Net or Fwd power. Net is Fwd-Ref... or delivered power. Fwd is the total incident power (including Ref) as displayed on typical wattmeters like a Bird 43.

# Operation cont'd

**Connecting Cable.** All LP-100s after serial #100 are supplied with RG-58U connecting cables between the coupler and main chassis. Earlier versions used RG-174U. This screen allows selection of the appropriate cable. It selects the proper correction table for the cable loss vs. frequency. The difference is only a couple percent at 6m, but eliminates recalibration when changing cables.

**Edit Gain/Phase Trims.** Allows editing of the Gain/Phase Zero adjustments, which are normally set automatically. The Dn button scrolls from 0-255 with wraparound for gain trim, and the Up button does the same for phase trim.

**Range.** Allows setting of maximum bargraph scale values for all three autoranging scales. The Dn button selects Low, Mid or High range, and the Up button allows scrolling through the various max power options. The displayed range includes 0.4dB overshoot (~10%) above the indicated value. Note: These ranges do not affect the numerical readout, which has no limits. Defaults are 15W, 100W, and 1500W.

**Bargraph Max Range.** Sets the maximum excursion of the bargraph for the three automatically selected ranges. The choices are...

Low – 5, 10, 15, 20, 25W

Mid – 50, 75, 100, 125, 150, 175, 200, 225, 250W

High – 500, 750, 1000, 1250, 1500, 1750, 2000, 2250, 2500W

Defaults are 15W, 100W and 1500W.

Each range includes 0.4dB overage, so that the 100W selection would extend to 110W, for example. **Note: These settings do not affect the numerical readout, which has no limits of any kind.**

The center button selects the range, and the right button sets the power level, with wraparound to the beginning value.

**Fast Bargraph Range.** Sets the width of the bargraph in Fast mode from 2dB to 10dB. This allows tailoring of the bargraph resolution for amplifier tuning to simulate an analog meter. The response is still logarithmic to minimize jitter, and be more like the typical square law analog meter response. The default is 9dB.

**Averaging Samples.** Sets the number of samples for power averaging, adjustable from 2 to 32 samples. Default is 8 samples.

**Peak Hold Time.** Sets the hold time in Slow (peak) mode. Adjustable from 0.25 to 5 seconds. The shortest time can be used for amplifier tuning, especially with a pulser. The default setting is 2 seconds for normal SSB or CW operation.

**Alarm User Setting.** Allows setting an alarm threshold other than the preset choices. Any setting from 1.0 to 5.0 is permissible.

After entering the Setup mode, these various screens can be accessed by cycling through them using the Mode button. In Setup mode, the Alarm button becomes a Dn (or Save or Select) button and the Fast/Slow button becomes Up (or Reset). You can adjust the value of the CAL constant for each screen using these buttons. The value of the CAL constant is stored in non-volatile memory. You may also want to write down your values on the page provided at the end of this manual.

## Screen Saver

The screen saver dims the screen after approx. 30 sec of inactivity, and marches your call sign across the screen after approx. 2 min. of inactivity. This is done to extend the life of the PLED display. Check the software section of the manual for instructions on programming your call sign into the LP-100. Application of RF power will return the LP-100 to normal display. Alternatively, pressing the Fast/Slow button will do the same thing if not in Calibration Mode. **Note: Make sure you are in the desired Fast/Slow mode after using the button to cancel the screen saver.**

## Normal Operation

In normal operation, the LP-100 is left in the Normal mode. For SSB or CW operation, you should use the Slow (or peak-hold) Power mode. This mode will show peak power and SWR and hold them for the preset hold time unless a higher peak is detected, at which time the timer resets. Do not use this mode for steady-state power or SWR measurements, as it will be affected by momentary power fluctuations that many modern rigs have.

The peak power reading can be as much as 30% higher than steady-state power readings taken in the Fast mode. This is because of the ability of the transmitter or amplifier to deliver short bursts of higher power due mainly to power supply regulation issues. This is especially true of older amplifiers with unregulated power supplies, but also is affected by the ALC timing characteristics of modern rigs in both CW and SSB. The peak detector in the LP-100 is very fast, and will grab even the smallest peak.



# Operation cont'd

Peak SWR will show values a little higher than steady-state at times due to the wide dynamic range of the LP-100. As power drops to below 100 mW during speech, the SWR detector can sometimes grab a higher peak because of the lower accuracy at extreme low power levels. The worst-case error in this case should be  $< .10$ . For best accuracy during measurements, use the fast mode and at least .5 watts of power. The directivity of the LP-100 can easily be greater than 40 dB as you may have noticed during calibration, even at low power.

For amplifier tuning, you should switch to Tune mode for fast update of both bargraph and numerical readout. The bargraph sampling in the LP-100 is about 100 samples/second, and it will display a single dit at 60 wpm, or a string of pulses as with a pulser or keyer set for high speed. Full accuracy should be attainable down to about 500 mW for both power and SWR. Good accuracy should still be maintained down to  $< 100$  mW. Note: The bargraph scale is fixed on the High scale in this mode to prevent autoranging from clouding adjustments. For antenna tuner adjustment, the fast mode is best, or dBm/RL if you prefer peaking rather than dipping.

Normally, the SWR Alarm should be set for 2.0:1 unless you purposely operate with an antenna that is close to 2.0:1 SWR. It is up to you whether to enable the Piezo transducer, by using JP1. In any case, it is recommended that you loop your amplifier PTT through the LP-100. This not only helps protect your amplifier, but also the coupler in the LP-100... especially if you have an older amplifier which is capable of delivering full power into a high SWR load.

## Vector Mode



In the vector mode, you can see the impedance of the load in two ways. The top line of the display shows the magnitude and phase of the complex impedance, and the lower line shows the resistive and reactive components, ie.  $R + jX$ . It is important to note here that the sign of the reactive, or imaginary component cannot be determined automatically by the LP-100.

If you QSY up from your current frequency, and the reactance goes up, then the reactance is inductive (sign is "+"), and conversely if it goes down, then the reactance is capacitive (sign is "-"). A suitable distance is QSY is about 100 kHz or more. The LP-Plot program has the ability to determine sign automatically, since it can control your transmitter's frequency. When it plots a range of frequencies, it uses the slope of the reactance curve to determine sign, and plots the results accordingly.

It is important to remember that the impedance displayed on the screen is referenced to the coupler LOAD port. This value is related to actual feedpoint impedance of the antenna by factors relating to the characteristic Z of the line, line length and loss. I plan to add the ability to display actual antenna feedpoint Z into the LP-100 VCP and Plot programs by providing input boxes for feedline type and length.

A simple way to provide reasonably accurate antenna Z on the LP-100 display would be to use a feedline which is a multiple of  $\frac{1}{2}$  wavelength in electrical length. There would still be some residual error due to feedline loss, but it would give a better representation of feedpoint Z. I am considering adding a CAL screen to allow selection of feedline loss to compensate for this, and I may also allow the future entry of feedline length and  $Z_0$  data. There will be more info on this and other Impedance related subjects in the upcoming Appendix A.

## dBm/RL Mode

Displays power in dBm from +15 to +64 dBm, and load integrity in dB of return loss from 0 to 49.9 dB.

## Direct Input/Field Strength Mode

Similar to dBm mode except that it is calibrated to display power from -15 dBm to +33 dBm. There is no return loss in this mode because it does not utilize the coupler. Power is supplied directly to one of the inputs on the back of the LP-100. This mode can be used for accurate low power bench measurements, as in checking the output to a transverter or the level of a local oscillator or mixer. It is also very useful for doing antenna field strength measurements, as in checking a beam pattern. This requires feeding a small pickup antenna to one of the inputs. **NOTE: The maximum power for the direct inputs is 2W.**

## Compression Mode

Under development. I started to add this as the LP-100 was nearing readiness for shipment. It will be completed in a future firmware update. It will show peak-to-average ratio, but I want to work on a steadier average algorithm before releasing it.

# Circuit Description

The LP-100 is unique in its design in several regards. Refer to the following block diagram during this discussion.

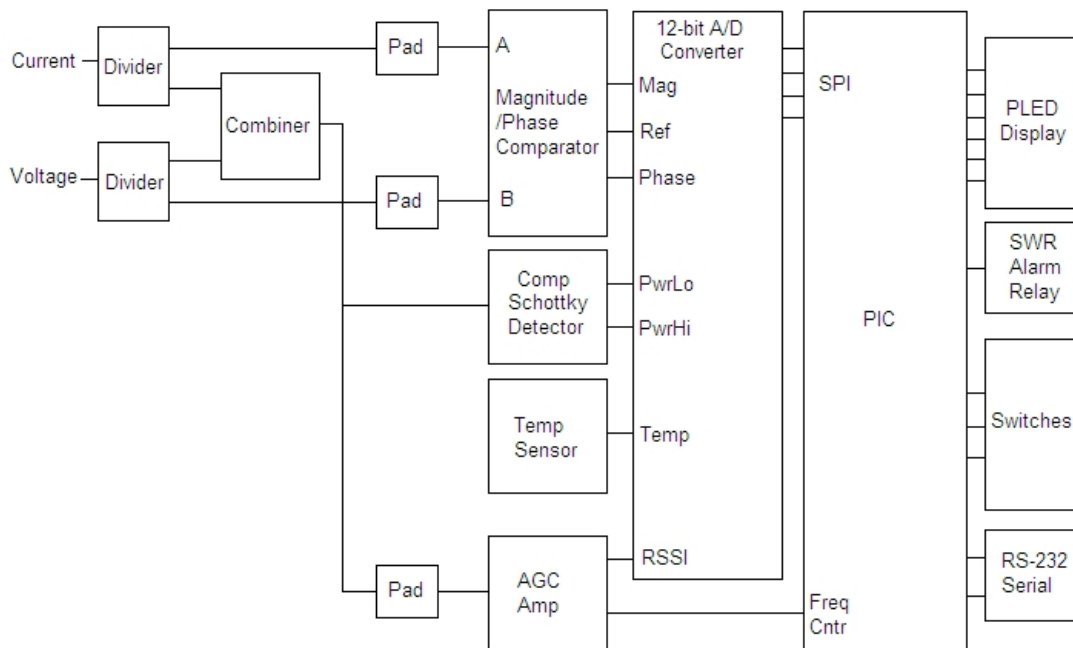

First, instead of using a coupler that produces forward and reflected power signals, the LP-100 uses a pair of transformers that sample current in the transmission line and voltage across the load. The samples are split into two paths, which provide signals to both the gain/phase comparator and the power detector.

With a 50 ohm non-reactive load, the levels of these two signals will be virtually identical, and the phase between them will be zero degrees. The combiner adds these two samples vectorially, providing a maximum output of 2x the input power with a perfect load, and proportionately less with less perfect loads.

The power sample is rectified in the Schottky diode detector, which uses a special dual diode package to eliminate errors associated with temperature tracking and forward / reverse voltage drop differences. The output of the detector is fed through precision voltage dividers to produce two power ranges, and in combination with a 12-bit A/D converter and precision 2.5V reference chip, provides an effective resolution of more than 13 bits.

The power sample also feeds an AGC amp which provides a constant, clean 5v p-p sine-wave output signal over a 50dB+ range of input power. This signal feeds the frequency counter in the PIC to allow automatic frequency detection at all power levels. This allows for automatic band-by-band calibration of the power readout of the LP-100.

The AGC amp also provides a DC "Received Signal Strength Indicator" which is used for a number of level detection tasks within the PIC. The A/D converter also receives temperature information from the temp sensor to compensate for any residual temperature related effects in the power detection circuitry.

The combiner also provides isolated signals to the gain/phase detector, providing 50dB of isolation between the signals, so that they can be accurately sampled at the input of the gain/phase comparator without affecting each other. The gain/phase comparator produces a DC voltage which is proportional to the log of the magnitude difference between its inputs, and another which is proportional to the phase difference between the inputs. These voltages are sampled by the A/D converter and the result is sent to the PIC over a Serial Peripheral Interface.

Remaining connections to the PIC include switch inputs for the three front panel switches, interfacing to the PLED display and an SWR alarm relay which is used to kill the PTT to your amplifier to protect both the antenna and amplifier. The SWR alarm also lights a front panel LED, and optionally can be jumpered to sound a piezo transducer. The PIC uses all these signals to calculate all the various displayed parameters.

## Circuit Description cont'd

Finally, the PIC provides a standard RS-232 serial interface for remote control and monitoring of the LP-100. Functions of the LP-100 can be controlled from a Windows® "Virtual Control Panel" program, either locally or over a network connection, including the internet. The PIC's firmware can also be updated through downloadable hex files which can be "flashed" into the PIC's memory. A program entitled MicroCode Loader (MCLoader), from Mecanique®, is provided to do this.

A Windows® charting program is also available to allow graphing of any of the LP-100s parameters including Z, R, X, SWR and phase angle vs. frequency. Future plans for the charting program include the possibility of a Smith Chart display, and I plan to add a translation function to both programs to allow for automatic transformation of coupler load Z to antenna feedpoint Z. The programs will provide for inputting feedline length and type for popular types of feedline.



# Schematic Page 2

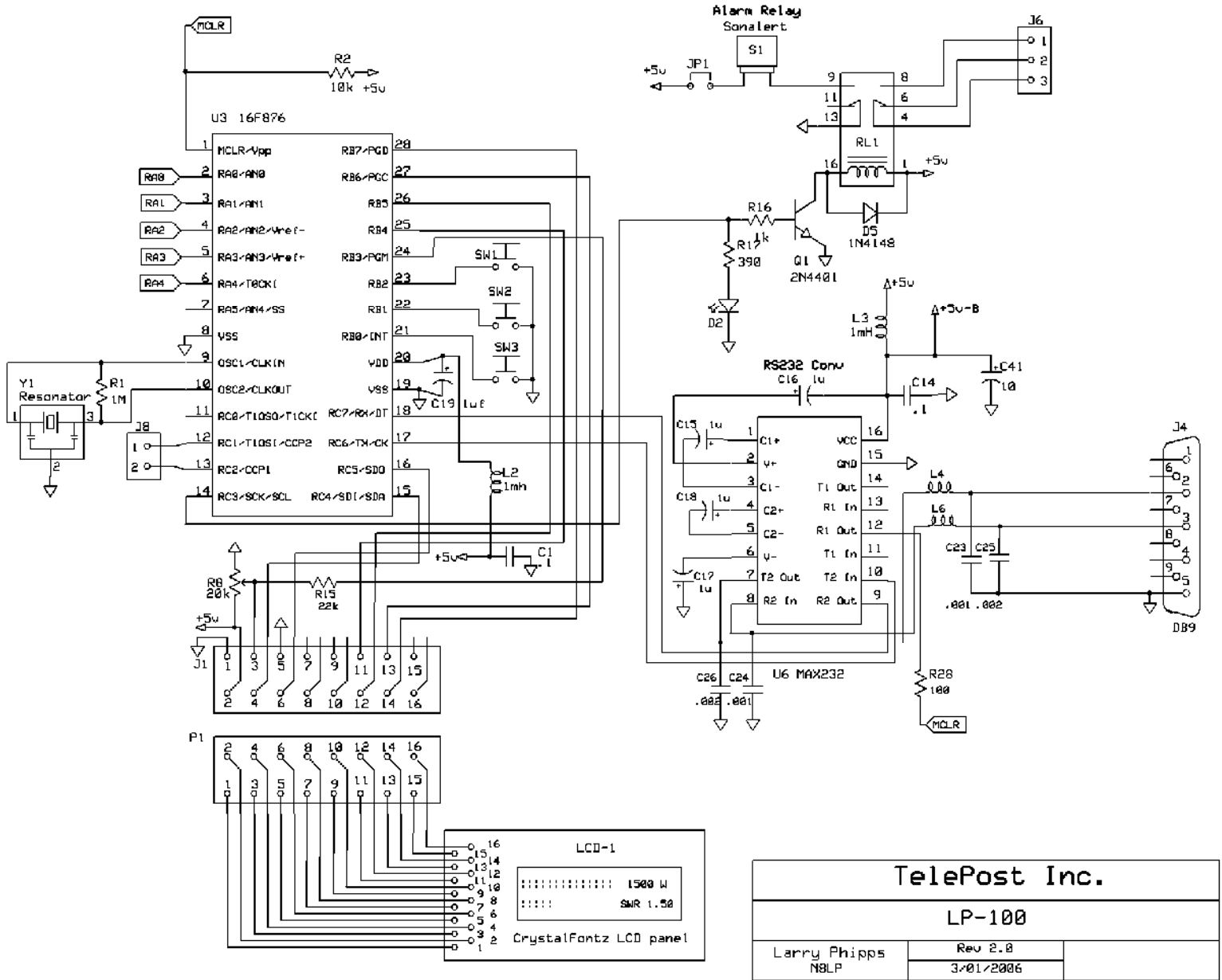

<b>TelePost Inc.</b>		
<b>LP-100</b>		
Larry Phipps N8LP	Rev 2.8 3/01/2006	

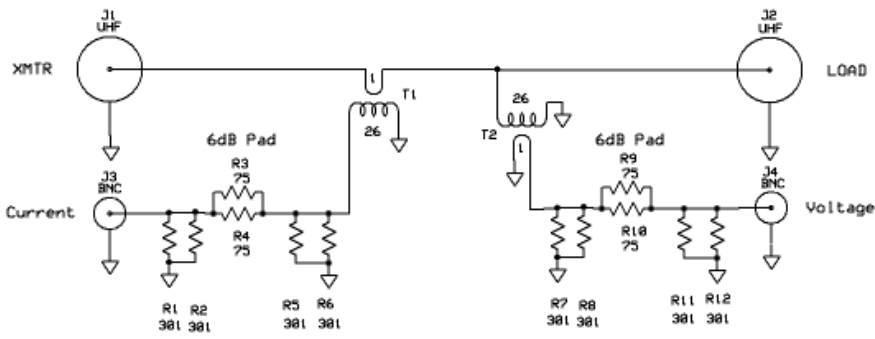

Coupler Schematic

# Troubleshooting

Below are some problems that have been reported and solutions. If you still have a problem, I am always available by email at [larry@telepostinc.com](mailto:larry@telepostinc.com) and the newly formed LP-100 Yahoo Group is available at <http://groups.yahoo.com/group/LP-100/> For excessive current, always check for solder bridges and proper orientation of ICs first. If a step calls for more than one IC to be added and current is excessive, remove the ICs and re-install one-by-one until you narrow the source of the high current.

Problem	Suggested solution
No +5 VDC at Initial Checkout Step 1.	Check wiring of U2 and D5, and that the white-striped wire on the power cord is connected to the + lead of the supply.
Excessive current at Initial Checkout Step 1.	Check for proper polarity on D5.
Excessive current at Initial Checkout Step 2.	Check for proper placement of U7 and U3 (PIC).
Improper display at Initial Checkout Step 2.	Check setting of R8 to make sure the contrast is in range. Check that Y1 is soldered properly. Check that the PLED cable is installed properly. If all this checks out, the PIC firmware may be bad. Try flashing with the latest firmware on the LP-100-Updates page.
Excessive current at Initial Checkout Step 3.	Check for proper placement of the added ICs.
Incorrect operation of buttons.	Check for good ground lead connection on three tactile switches.
Incorrect values for RSSI or Temp.	Check U5 & U8 for proper orientation. Check output voltage of U5 at pin 6. It should be very close to 2.500 V. Check for proper orientation of U7 for Temp. Check soldering around U9 for RSSI.
Excessive current at Initial Checkout Step 4.	Check the added jumper between U4 pins 7&8 to make sure it is not touching ground (on ser #s 1-100 only). Check R39 and C42 for proper wiring.
Power reading is erratic	Make sure C37 wasn't installed. This part is shown on the silk-screening, but was deleted before production along with 4 other parts. This is covered in the Overview paragraph at the top of the Assembly section. Also, make sure that the standoff on coupler xfmr T2 is firmly bolted down and that the short wire is also solidly attached. Make sure that the two BNC connectors on the controller PCB are soldered properly.
Frequency counter is not registering the correct band	Check U9 by looking at the RSSI voltage on the Reference CAL screen. It should vary with applied RF power. Normal voltages are ~0.400V at 5W, ~0.660V at 100W. Also check the wiring of T2, and make sure the enamel has been removed from the wires, and that the wires are properly soldered to the pads.
Temperature is not being displayed	Check that U7 is installed properly. Remember, the silk-screening is backwards for this part on serial #s 1-100.

# Software

## Connecting to the computer

The LP-100 provides a RS-232 serial port. The serial settings are 38,400 baud, 8 bits, no parity, 1 stop bit. The required cable is a straight through (not crossover or null modem), with a male DB9 at one end and a female DB9 at the other. With typical motherboard or bus card provided serial ports, there are no settings required in the computer or driver, just in the application which controls the LP-100. In the case of the provided software such as LP-100 VCP and Plot, these settings are automatic except for com port selection. Any free com port from 1-15 is acceptable.

If your computer doesn't have a serial port, which is becoming increasingly the case, there is a simple solution as long as the computer has a USB port, which is usually the case. A number of USB to serial adapters are available on the web or at computer/appliance stores. The LP-100 has been successfully used with a number of these. I can personally vouch for the Keyspan USA-19HS, although I don't know if they have a driver yet for the 64-bit version of Microsoft Vista. An inexpensive converter that some have reported good results with is the Y-105 from ByteRunner, [www.byterunner.com](http://www.byterunner.com). They cost \$8.69 plus shipping as of this date, and provide full handshaking (not needed for LP-100, but useful for some rigs and devices) and Vista support. This adapter uses the Prolific chipset, which may not be supported in the future. ByteRunner also sells an adapter which uses the well supported FTDI chipset for about \$18. These adapters are both much cheaper than the ones typically sold at computer stores, and should work well. I have been asked about a USB port for the LP-100, and it would be easy to do, but since all ham software has native RS-232 com support, and older machines don't have USB ports, I think a RS-232 port with an inexpensive USB adapter where needed is the most flexible choice.

The LP-100 has been used successfully over the Internet using serial device servers such as those offered by Lantronix and Digi. I have personally used several of the Lantronix models with no problems.

## LP-100 VCP

The LP-100 VCP (Virtual Control Panel) is provided for computer or remote operation of your LP-100 wattmeter. The LP-100 VCP allows you to control the basic functions of the LP-100, and it also allows you to monitor the LP-100 parameters remotely.

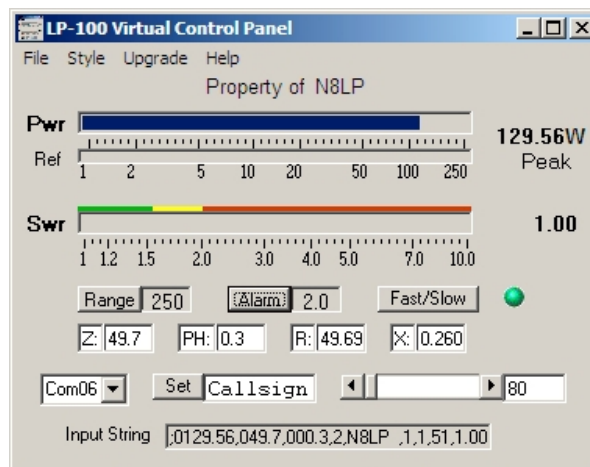
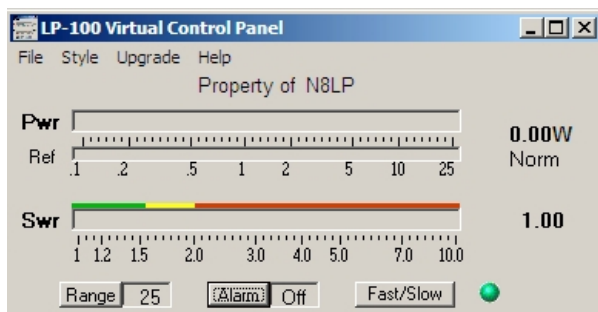

### Control...

Alarm Set  
Fast/Slow Mode  
Call Sign Entry

### Monitoring...

Power SWR  
Impedance Phase  
Resistance Reactance  
Alarm Status

There are three views for the VCP, selectable under the Style pulldown. The two shown above, plus one which shows all but the setup info. The Menu choices provide the following functionality...

Style: Selects among the three views mentioned above

Upgrade: Launches the MCLoader program. This program can also be launched manually by adding a shortcut to the program.

Help: A work in progress.

The setup controls include Com port selection, callsign entry and a polling rate slider, adjustable from 50 msec to 5 sec. The normal setting is 80 msec, which gives an update rate of 12 samples per second. On slower computers, or over the internet, you can use a slower rate.

# Software cont'd

The buttons on the VCP perform the following functions...

- \* Range: Allows switching the maximum power range of the display. Choices are 25, 250, 2500W and Auto for autoranging.
- \* Alarm: Sets the SWR Alarm set point. Choices are Off, 1.5, 2.0, 2.5, 3.0. If the alarm on the LP-100 trips, the Alarm button turns red.
- \* Fast/Slow: Switches between normal and peak-hold modes. The current mode is displayed under the power reading.

There are two other versions coming for use with TRX-Manager. The first, called LP-100 VCP Slave, allows the LP-100 to broadcast its data to TRX-Manager for display inside TRX-Manager, either locally or over the internet. The other, LP-100 VCP Master, allows the LP-100 to use TRX-Manager's remote telnet facility to make a remote connection between the LP-100 and the VCP. In addition to the LP-100 VCP, you can communicate with the LP-100 with a terminal program or your own software using the following commands...

- ;A? Increments Alarm Set Point selection
  - ;M? Increments Mode selection
  - ;F? Toggles Power Fast/Slow selection
  - ;C "Callsign" ? Sets callsign, where "Callsign" is a 6-digit alphanumeric value. Examples...
  - ;CN8LP ? ;CWA1ABC? (Add spaces to pad out to 6 digits)
  - ;P? Poll for data. Example of response...
  - ;1457.00,49.3,005.0,2,N8LP ,0,2,61.6,1.02
- From left to right, the comma separated values represent...

Power, Z, Phase, SWR Alarm Set Point: 0=off, 1=1.5, 2=2.0, 3=2.5, 4=3.0, Callsign (6 digits with space padding), Power range: 0=High, 1=Mid, 2=Low, Peak Hold Mode: 0=Fast, 1= Peak Hold, dBm, SWR

The serial settings are 38,400 baud, 8 bits, no parity, 1 stop bit. **NOTE: Firmware versions before 1.0.3 used a baud rate of 19,200 and did not report dBm or SWR values.**

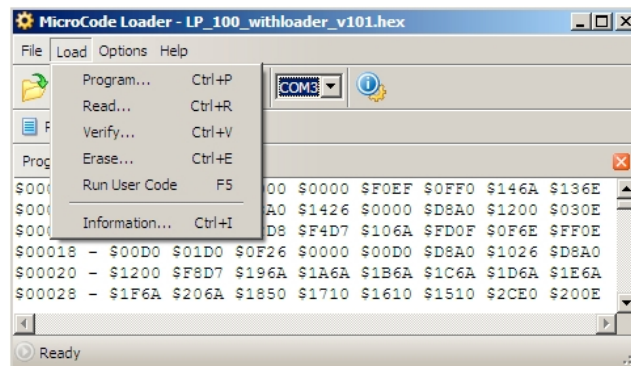

## MicroCode Loader

Before attempting to flash new firmware, make sure the connection between the LP-100 and PC is solid. You can do this by running the VCP program. MicroCode Loader works with the MCLoader bootstrap loader program installed on your PIC. It allows the user to easily update the firmware in the LP-100. The correct settings for MicroCode Loader, found under the Options pulldown, are as shown. **NOTE: Make sure you settings match these before starting. If you select Program Data, the factory defaults will be loaded into your CAL constant table.**

All that is required is to download the latest version of the firmware from my website, save it to a convenient folder, such as C:\Program Files\LP-100-VCP\Updates and then load the file into MCLoader using the File>Open menu. **Note: It is important to open the file you want each time you launch MCLoader, or else it will start up with the last used file, and you may forget to open a new file and reprogram your LP-100 with an older version. It is even possible that you might have a file from another device loaded, since MCLoader is used by other manufacturers as well.**

Once MCLoader is running, and you have the correct firmware file open, you need to set the correct LP-100 com port for the LP-100, and set the Baud Rate to 19,200 (under Options). When all of this is done, click on Load>Program. You will see a message to Reset the PIC. This is done on older firmware by cycling the power to the LP-100. On firmware after ver. 1.1.47b, you can do a software reset by entering Setup (hold Mode button for 1 second) until the first CAL screen is displayed, release the mode button and then press Alarm. A progress bar in MCLoader will show the progress of the programming, and the LP-100 will start again when programming is finished. The "Splash" screen will now indicate the new version at startup. During programming, the LP-100 displays "PIC Reset" if the software reset is used.

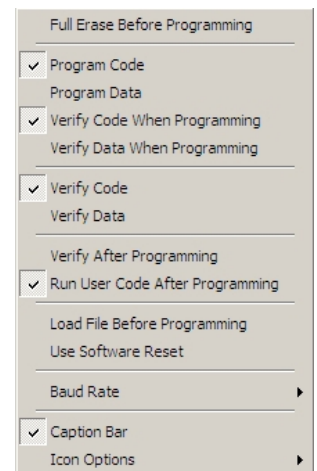



## LP-100 Plot

Plot version 0.99 is available for download on the LP-100 Current Software page. An html help file is also available there with instructions for installation and use.

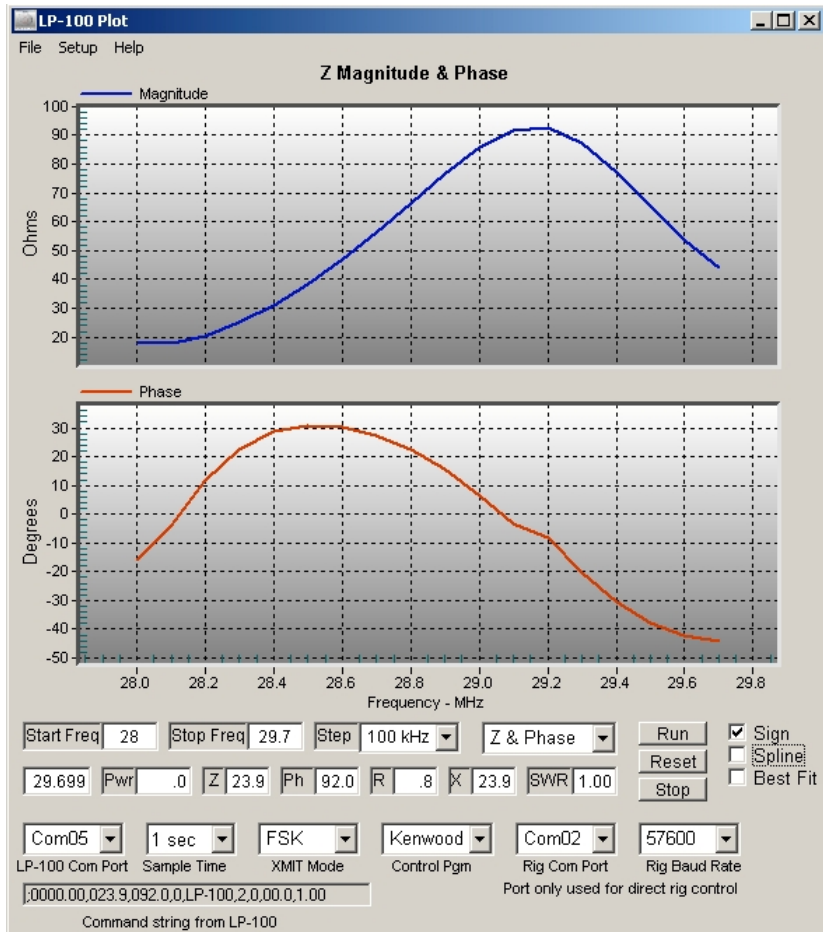

# Specifications

(after factory calibration, preliminary data subject to change without notice)

Useful Power Range:	0.05W – 2500W
Power Accuracy:	<5% above 0.5W, <10% below 0.5W, +/- 1LSB (2% typical)
SWR Range:	1.00 to 9.99
SWR Accuracy:	<5% above 0.5W, <10% below 0.5W, +/- 1LSB (2% typical)
Directivity:	30+ dB, 160 – 6 meters (40 dB typical)
Insertion Loss	<0.05 dB, 1.8-50 mHz, (typical)
Impedance:	0-999.9 ohms Z, R and  X , <5% (typical, 10-500 ohms)
Phase:	0-180.0 degrees, <5 degrees (<3 degrees typical, 10-170 degrees)
Frequency counter:	1 MHz to >100 MHz, +15 to +23 dBm sensitivity (~0.5% accuracy)
Power handling	1500W continuous duty, 2500W peak
Bargraph response	>90 Hz
Direct Inputs:	-15 to +33 dBm, 50 ohms, 0.1 to 650 MHz +/-1.5 dB, 2W max
DC Power:	11-15 VDC @ 160 ma
Operating temp range:	0 to 50 degrees C
Clock:	40 mHz
Program memory:	64kB
Size:	Controller: 6.0" x 6.0" x 2.75" (5.08cm x 5.08cm x 6.99cm) Coupler: 2.25" x 2.40" x 5.00" (5.72cm x 6.1cm x 12.7cm)
Weight:	3 pounds (1.36 kg)

## CAL Table

Description	Fine Power	Gain Zero	Phase Zero
160m			
80m			
60m			
40m			
30m			
20m			
17m			
15m			
12m			
10m			
6m			
Offset Trim			
Master Power Trim			
Gain Slope Trim			
Phase Slope Trim			
Lo/Hi Power Trim			
Reference			

Log the initial CAL constants for your LP-100 in this table. If you ever make changes, you can log additional constants in the spaces provided.

# Warranty

Factory assembled LP-100s are warranted against failure due to defects in materials and workmanship for 90 days from the date of purchase from TelePost Inc. Warranty does not cover damage caused by abuse, accident, improper or abnormal usage, improper installation, alteration, lightning or other incidence of excessive voltage or current.

Units built from kit are only covered against failure due to defects in materials, with the further limitation that any parts damaged as a result of improper kit assembly are not warranted. Parts delivered damaged or missing will be replaced by TelePost Inc. at company's expense, including shipping.

If failure occurs within the warranty period, return the LP-100 to TelePost Inc. at your shipping expense. The device will be repaired or replaced, at our option, without charge, and returned to you at our shipping expense. Repaired or replaced items are warranted for the remainder of the original warranty period. You will be charged for repair or replacement of the LP-100 made after the expiration of the warranty period or where, in our reasonable opinion, the damage is due to improper assembly of the kit.

TelePost Inc. shall have no liability or responsibility to customer or any other person or entity with respect to any liability, loss or damage caused directly or indirectly by use or performance of the product or arising out of any breach of this warranty, including, but not limited to, any damages resulting from inconvenience, loss of time, data, property, revenue or profit, or any indirect, special incidental, or consequential damages, even if TelePost Inc. has been advised of such damages.

**Under no circumstances is TelePost Inc. liable for damage to your amateur radio equipment resulting from use of the LP-100, whether in accordance with the instructions in this Manual or otherwise.**

# Appendix A