

## S Series Class 300 2-pc full port SS ball valve

# SF-2F-300

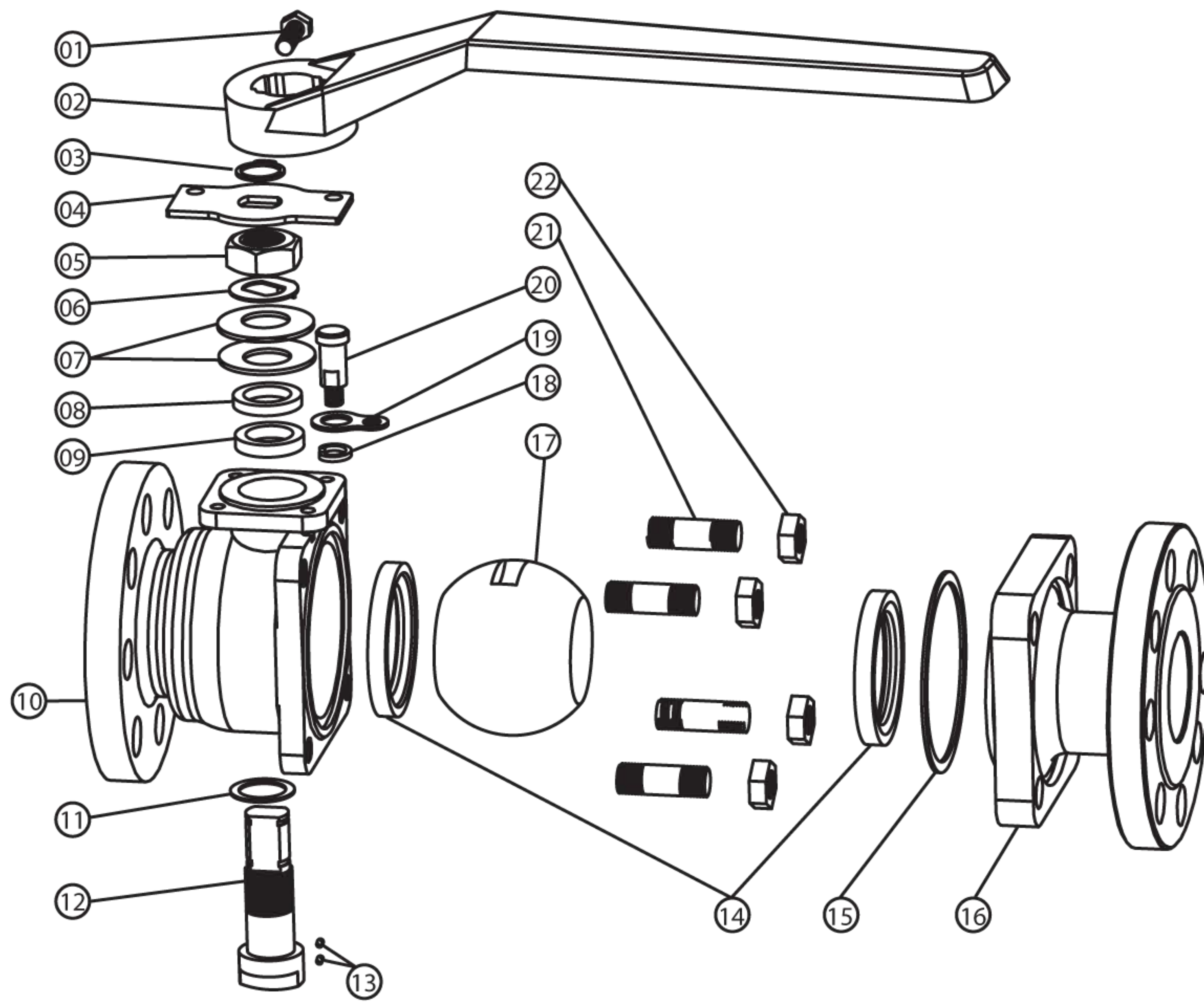

### Specification

- ❖ Size range: ½"~6"
- ❖ Rating: Class 300
- ❖ Construction: Two-piece body, with floating ball design
- ❖ Flow bore: Full port

### Product features

- ❖ Design conformed to ANSI B16.34
- ❖ Blowout-proof stem
- ❖ API 607 5<sup>th</sup> Edition fire-safe test approved
- ❖ Materials complied with NACE MR0175
- ❖ Mounting pad to actuator complied with ISO 5211
- ❖ Anti-static design

### Material list

No.	Part name	Material	Qty	Remarks
1	Screw	Carbon steel plated	1	
2	Handle	Ductile iron	1	
3	Retaining ring	Carbon steel	1	
4	Stopper plate	Stainless steel 304 / A276	1	
5	Gland nut	Stainless steel 304 / A276	1	
6	Lock washer	Stainless steel 304 / A276	1	
7	Belleville washer	Stainless steel 301	2	
8	Gland	Stainless steel 304 / A276	1	
9	Packing	Graphite	1 set	Optional material: PTFE in non fire-safe model
10	Body	Stainless steel A351 Gr. CF8M	1	
11	Thrust washer	Reinforced Teflon 15% GFT	1	
12	Stem	Stainless steel 316 / A276	1	
13	Anti-static device	Stainless steel 304 / A276	2 sets	
14	Seat	PTFE (TFM-1600)	2	
15	Body seal	Graphite	1	Optional material: PTFE in non fire-safe model
16	Cap	Stainless steel A351 Gr. CF8M	1	
17	Ball	Stainless steel A351 Gr. CF8M	1	
18	Stem washer	Stainless steel 304 / A276	1	
19	Lock plate	Stainless steel 304 / A276	1	
20	Stopper pin	Stainless steel 304 / A276	1	
21	Stud bolt	A193 Gr. B8M	1 set	
22	Bolt nut	A194 Gr. 8MA	1 set	

**S Series Class 300**  
**2-pc full port**  
**SS ball valve**

**SF-2F-300**

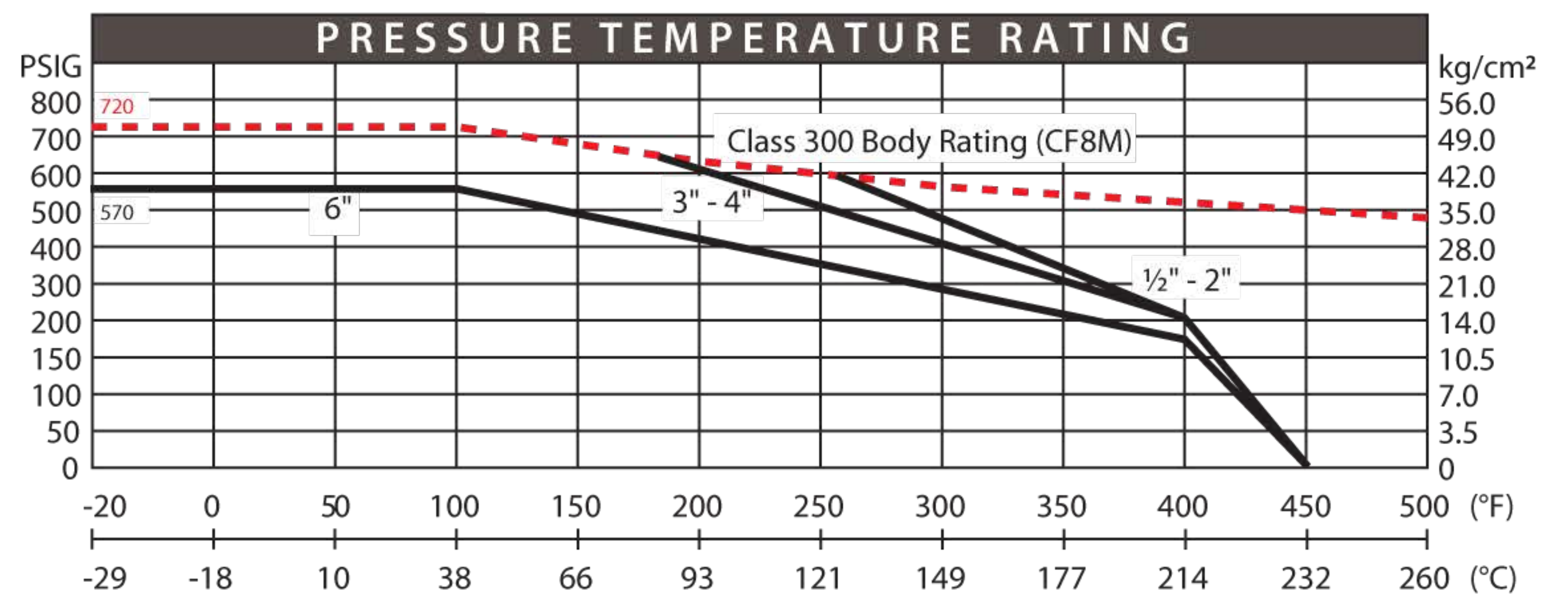
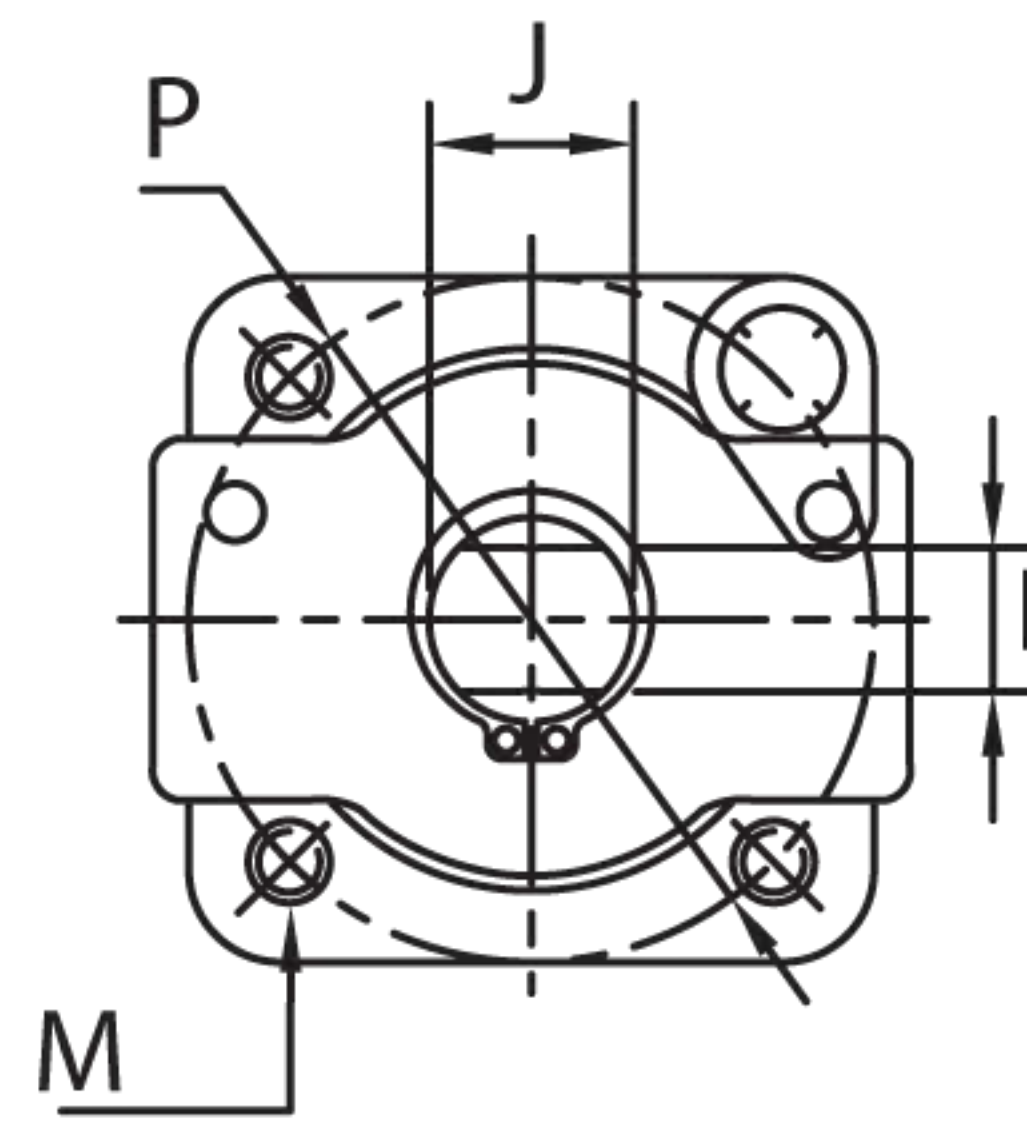
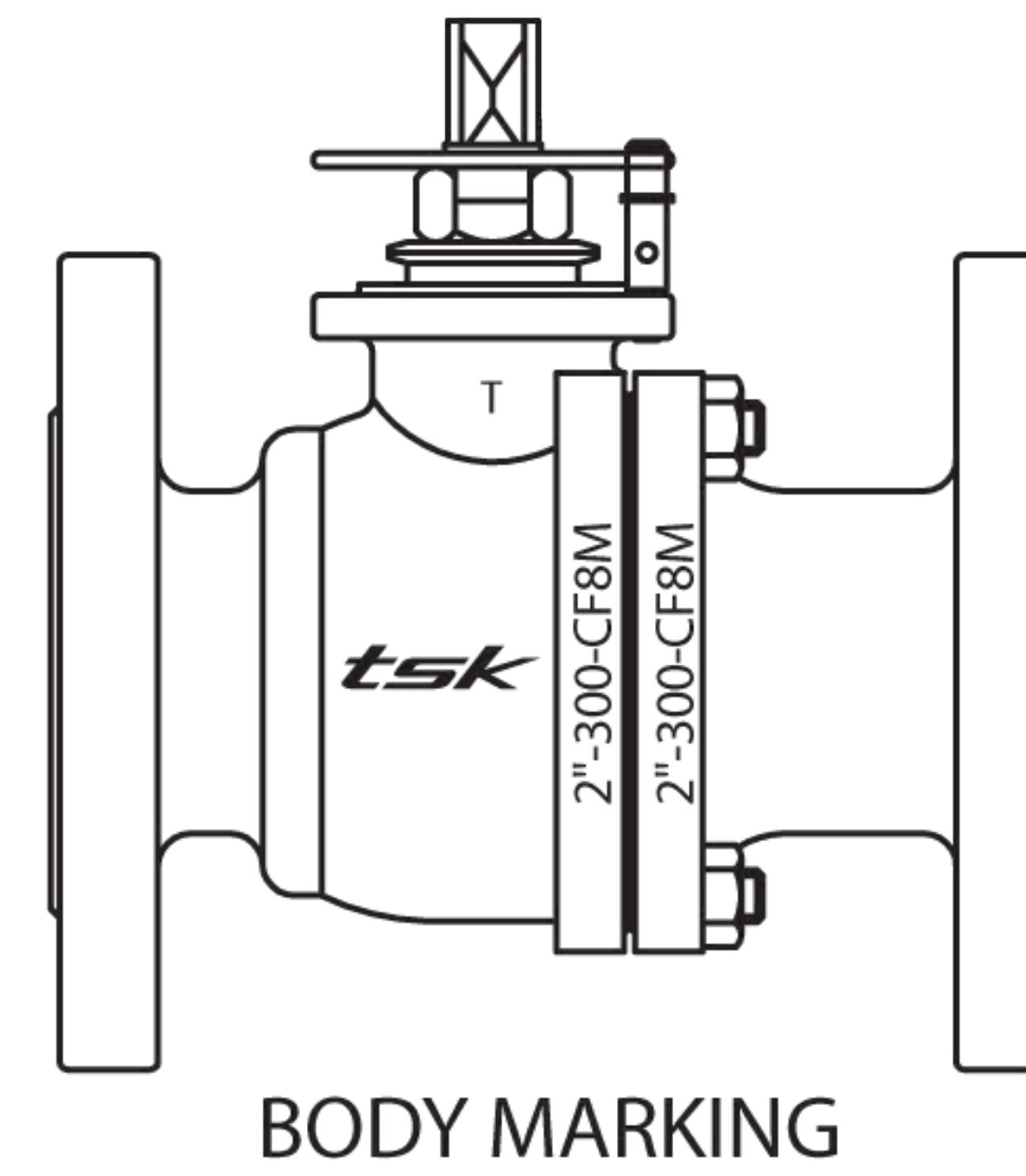
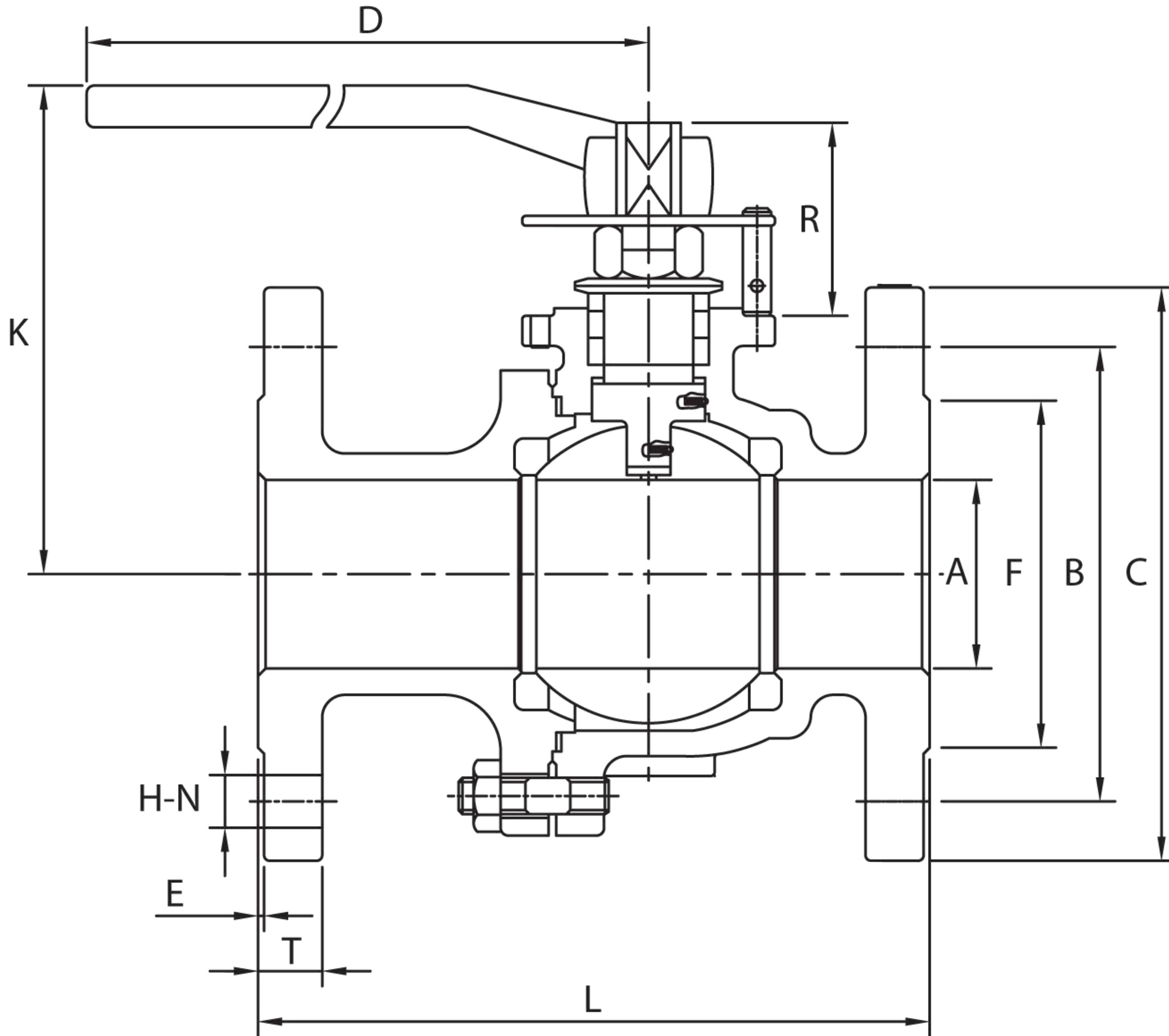

**DIMENSIONS**

size (mm/in)	A	B	C	D	E	F	H	I	J	K	L	M	N	P	T	R	ISO 5211 flange
1/2"	15	66.5	95	130	1.6	35	16	7	10	78.5	140	1/4" UNC	4	36	14.2	27	F03
	0.59	2.62	3.75	5.12	0.06	1.38	0.62	0.28	0.39	3.09	5.50			1.42	0.56	1.06	
3/4"	19	82.5	117	130	1.6	43	19	7	10	81.5	152.5	1/4" UNC	4	36	15.8	27	F03
	0.75	3.25	4.62	5.12	0.06	1.69	0.75	0.28	0.39	3.21	6.00			1.42	0.62	1.06	
1"	24	89.0	124	160	1.6	51	19	10	14	97.5	165	1/4" UNC	4	50	17.5	35.5	F05
	0.95	3.50	4.88	6.30	0.06	2.00	0.75	0.39	0.55	3.84	6.50			1.97	0.69	1.40	
1 1/2"	38	114.5	156	230	1.6	73	22	14	20	120.5	190.5	5/16" UNC	4	70	20.6	49	F07
	1.50	4.50	6.14	9.06	0.06	2.88	0.88	0.55	0.79	4.74	7.50			2.76	0.81	1.93	
2"	50	127.0	165	230	1.6	92	19	14	20	129.5	216	5/16" UNC	8	70	22.3	49	F07
	1.97	5.00	6.50	9.06	0.06	3.62	0.75	0.55	0.79	5.10	8.50			2.76	0.88	1.93	
2 1/2"	65	149.4	190.5	230	1.6	104.6	22	14	20	139.5	241.3	5/16" UNC	8	70	25.4	49	F07
	2.56	5.88	7.50	9.06	0.06	4.12	0.88	0.55	0.79	5.49	9.50			2.76	1.00	1.93	
3"	76	168	210	400	1.6	127	22	17	25	177	283	3/8" UNC	8	102	28.5	61	F10
	3.00	6.62	8.27	15.75	0.06	5.00	0.88	0.67	0.98	6.97	11.14			4.02	1.12	2.40	
4"	100	200	254	460	1.6	157	22	17	25	193	305	3/8" UNC	8	102	31.8	61	F10
	3.94	7.87	10.00	18.11	0.06	6.18	0.88	0.67	0.98	7.60	12.00			4.02	1.25	2.40	
6"	150	270	318	1000	1.6	216	22	25	36	274	403	5/8" UNC	12	140	36.6	90	F14
	5.91	10.63	12.52	39.37	0.06	8.50	0.88	0.98	1.42	10.79	15.87			5.51	1.44	3.54	