

2007 Hummer H3

2007 BRAKES Antilock Brake System - H3

2007 BRAKES

Antilock Brake System - H3

SPECIFICATIONS

FASTENER TIGHTENING SPECIFICATIONS

Fastener Tightening Specifications

Application	Specification	
	Metric	English
BPMV Module Mounting Bolts	32 N.m	24 lb ft
Brake Fluid Level Sensor Harness Bracket Bolt	8 N.m	71 lb ft
Brake Pipe Fittings	19 N.m	14 lb ft
Longitudinal Accelerometer Nut	9 N.m	80 lb in
Master Cylinder Nuts	30 N.m	22 lb ft
Wheel Speed Sensor Harness Clip Bolt	9 N.m	80 lb in
Wheel Speed Sensor Mounting Bolt	18 N.m	13 lb ft

VISUAL IDENTIFICATION

DISASSEMBLED VIEWS

2007 Hummer H3

2007 BRAKES Antilock Brake System - H3

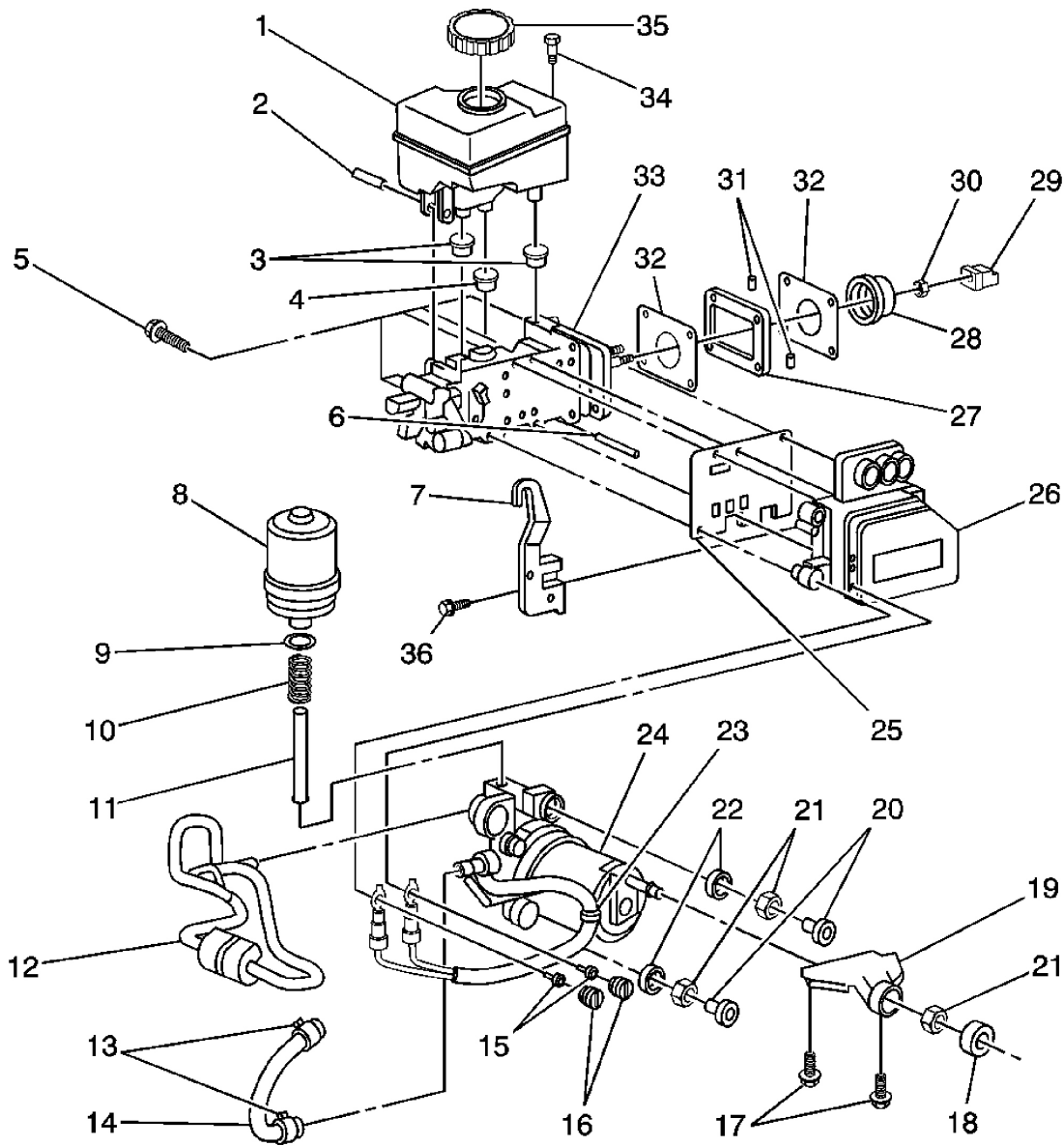

Fig. 1: Antilock Brakes Disassembled Views
 Courtesy of GENERAL MOTORS CORP.

Callouts For Fig. 1

Callout	Component Name
1	Brake Master Cylinder Reservoir
2	Reservoir Pin
3	Brake Master Cylinder Grommet
4	Brake Master Cylinder Grommet

2007 Hummer H3

2007 BRAKES Antilock Brake System - H3

5	Electronic Brake and Traction Control Module Bolt
6	Electronic Brake and Traction Control Module Locator
7	Brake Fluid Level Indicator Wiring Harness Bracket
8	Power Brake Booster Pump Fluid Accumulator
9	Power Brake Booster Pump Fluid Accumulator (O-Ring) Seal
10	Power Brake Booster Pump Fluid Accumulator Fitting Spring
11	Power Brake Booster Pump Fluid Accumulator Fitting
12	Power Brake Booster Outlet Front Pipe
13	Power Brake Booster Pump Inlet Hose Clamp
14	Power Brake Booster Inlet Hose
15	Power Brake Booster Pump Harness Strap Bolt
16	Electronic Brake Control Wiring Plug
17	Power Brake Boost Pump Bracket ASM Bolt
18	Power Brake Booster Pump Damper Retainer
19	Power Brake Boost Pump Bracket
20	Power Brake Booster Pump Locator Pin
21	Power Brake Booster Pump Damper
22	Power Brake Booster Pump Damper Retainer
23	Power Brake Booster Pump Harness Strap
24	Power Brake Booster Pump ASM Motor
25	Electronic Brake and Traction Control Module ASM Gasket
26	Electronic Brake and Traction Control (w/Brake Pressure Modulator Valve) ASM Module
27	Brake Master Cylinder Spacer
28	Brake Pedal Push Rod Boot
29	Brake Pedal Push Rod Clevis
30	Brake Pedal Push Rod Clevis Nut
31	Brake Master Cylinder Spacer
32	Brake Master Cylinder Spacer Gasket
33	Brake Master Cylinder
34	Brake Master Cylinder Reservoir Bolt
35	Brake Master Cylinder Reservoir ASM Cap
36	Brake Fluid Level Indicator Wiring Harness Bracket Bolt

SCHEMATIC AND ROUTING DIAGRAMS

ANTILOCK BRAKE SYSTEM SCHEMATIC ICONS**Antilock Brake System Schematic Icons**

Icon	Icon Definition
	<p>IMPORTANT: Twisted-pair wires provide an effective shield that helps protect sensitive electronic components from electrical interference. If the wires were covered with shielding, install new shielding.</p> <p>In order to prevent electrical interference from degrading the performance of the connected components, you must maintain the proper specification when making any repairs to the twisted-pair wires shown :</p> <ul style="list-style-type: none">• The wires must be twisted a minimum of 9 turns per 31 cm (12 in) as measured anywhere along the length of the wires.• The outside diameter of the twisted wires must not exceed 6.0 mm (0.25 in).

ANTILOCK BRAKE SYSTEM SCHEMATICS

2007 Hummer H3

2007 BRAKES Antilock Brake System - H3

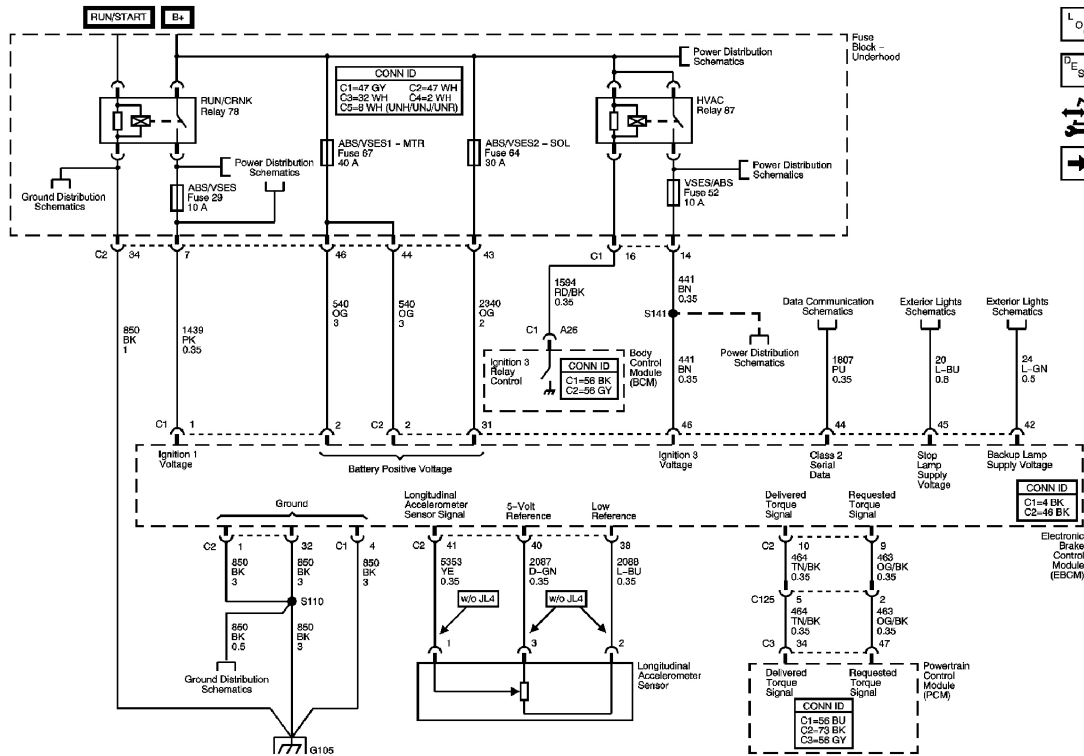

Fig. 2: Power, Ground and Electronic Brake Control Module (EBCM) Schematic
 Courtesy of GENERAL MOTORS CORP.

2007 Hummer H3

2007 BRAKES Antilock Brake System - H3

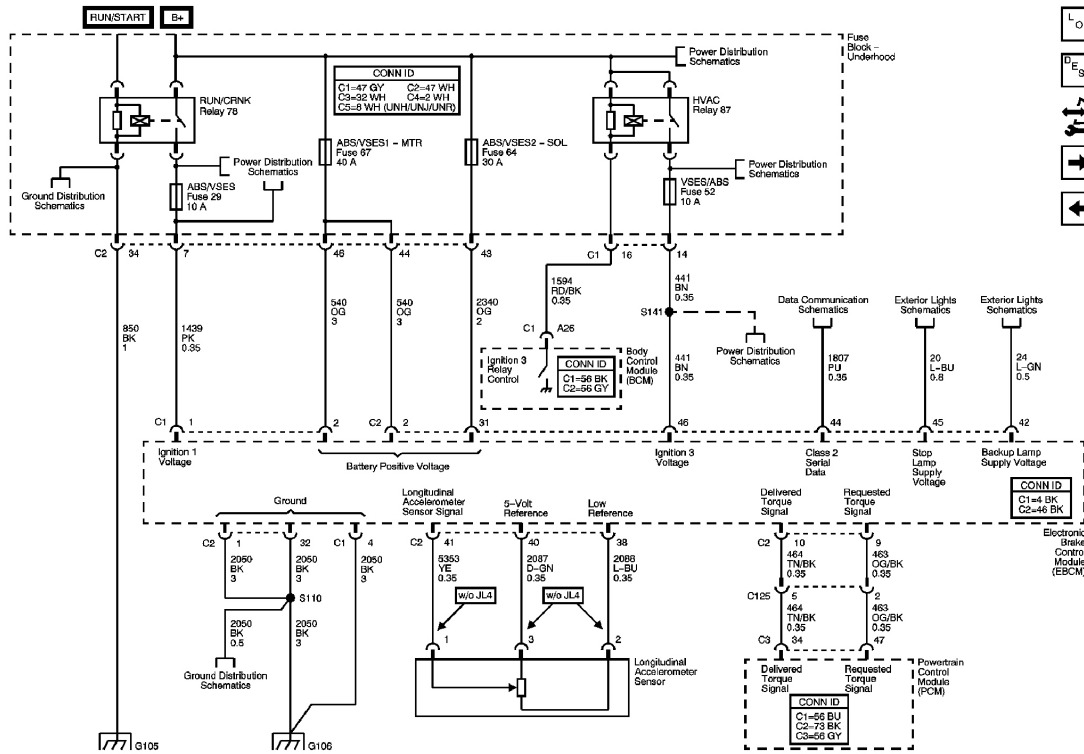

Fig. 3: Power, Ground and Electronic Brake Control Module (EBCM) Schematic - RHD
 Courtesy of GENERAL MOTORS CORP.

2007 Hummer H3

2007 BRAKES Antilock Brake System - H3

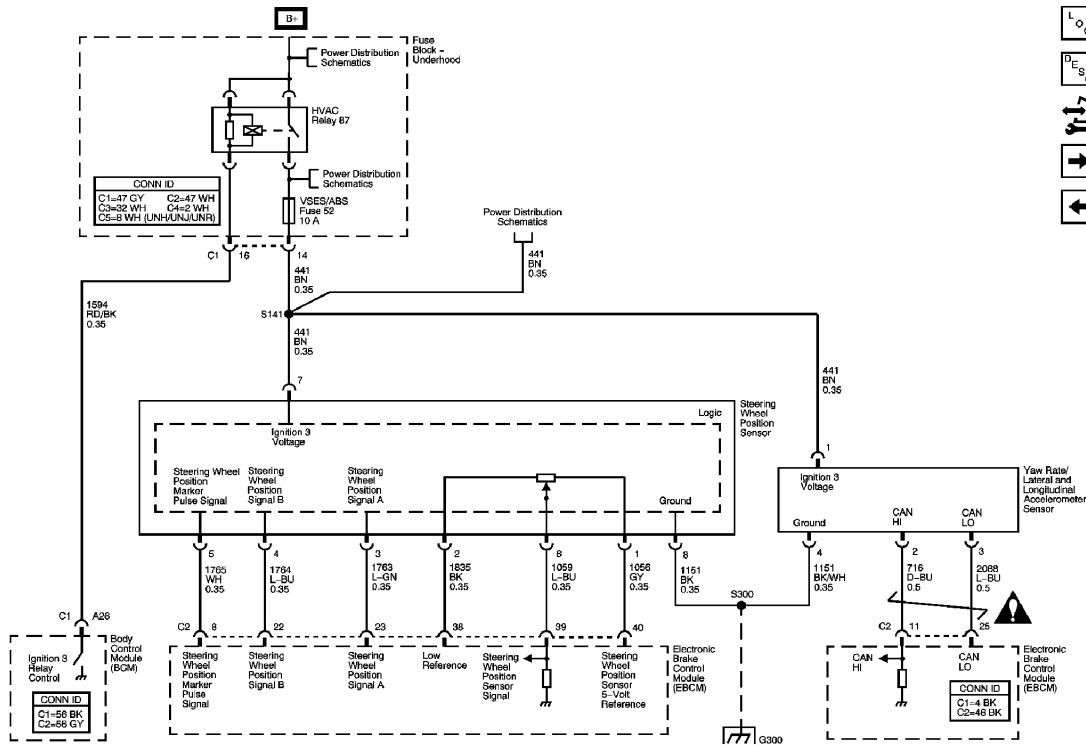

Fig. 5: Steering Wheel Position Sensor and Yaw Rate/Lateral and Longitudinal Accelerometer Sensor Schematic w/JL4
Courtesy of GENERAL MOTORS CORP.

2007 Hummer H3

2007 BRAKES Antilock Brake System - H3

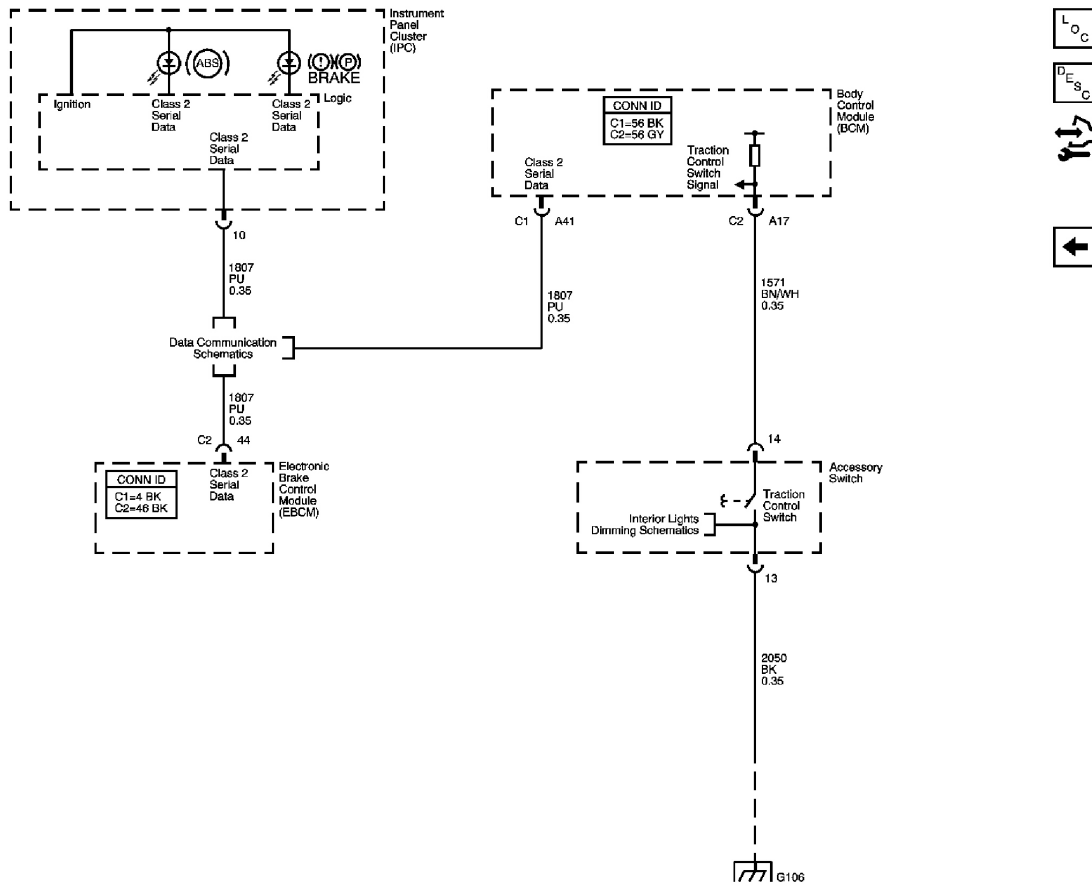

Fig. 6: Indicator Lamps and Traction Control Switch Schematic
Courtesy of GENERAL MOTORS CORP.

COMPONENT LOCATOR

ANTILOCK BRAKE SYSTEM COMPONENT VIEWS

2007 Hummer H3

2007 BRAKES Antilock Brake System - H3

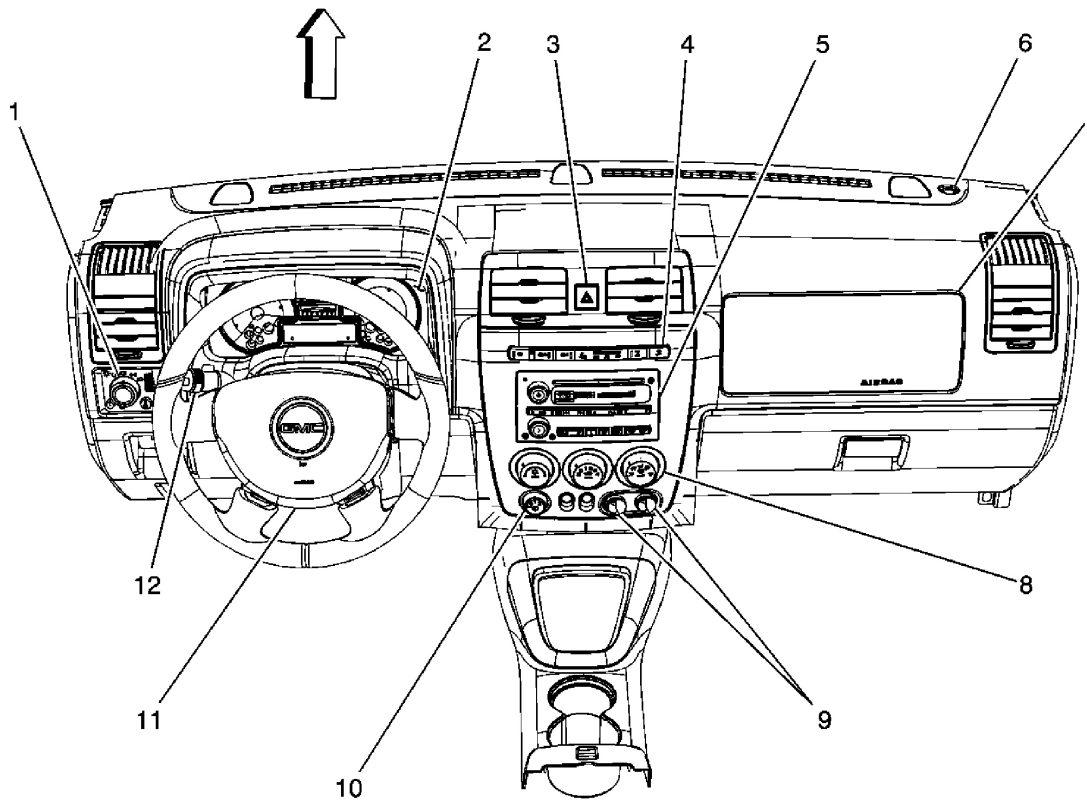

Fig. 7: Identifying I/P Harness Components
Courtesy of GENERAL MOTORS CORP.

Callouts For Fig. 7

Callout	Component Name
1	Headlamp Switch
2	Instrument Panel Cluster (IPC)
3	Hazard Switch
4	Accessory Switch
5	Radio
6	Ambient Light Sensor
7	Inflatable Restraint I/P Module
8	HVAC Control Module
9	Auxiliary Power Outlets - Front
10	Rear Window Wiper/Washer Switch
11	Inflatable Restraint Steering Wheel Module
12	Turn Signal/Multifunction Switch

2007 Hummer H3

2007 BRAKES Antilock Brake System - H3

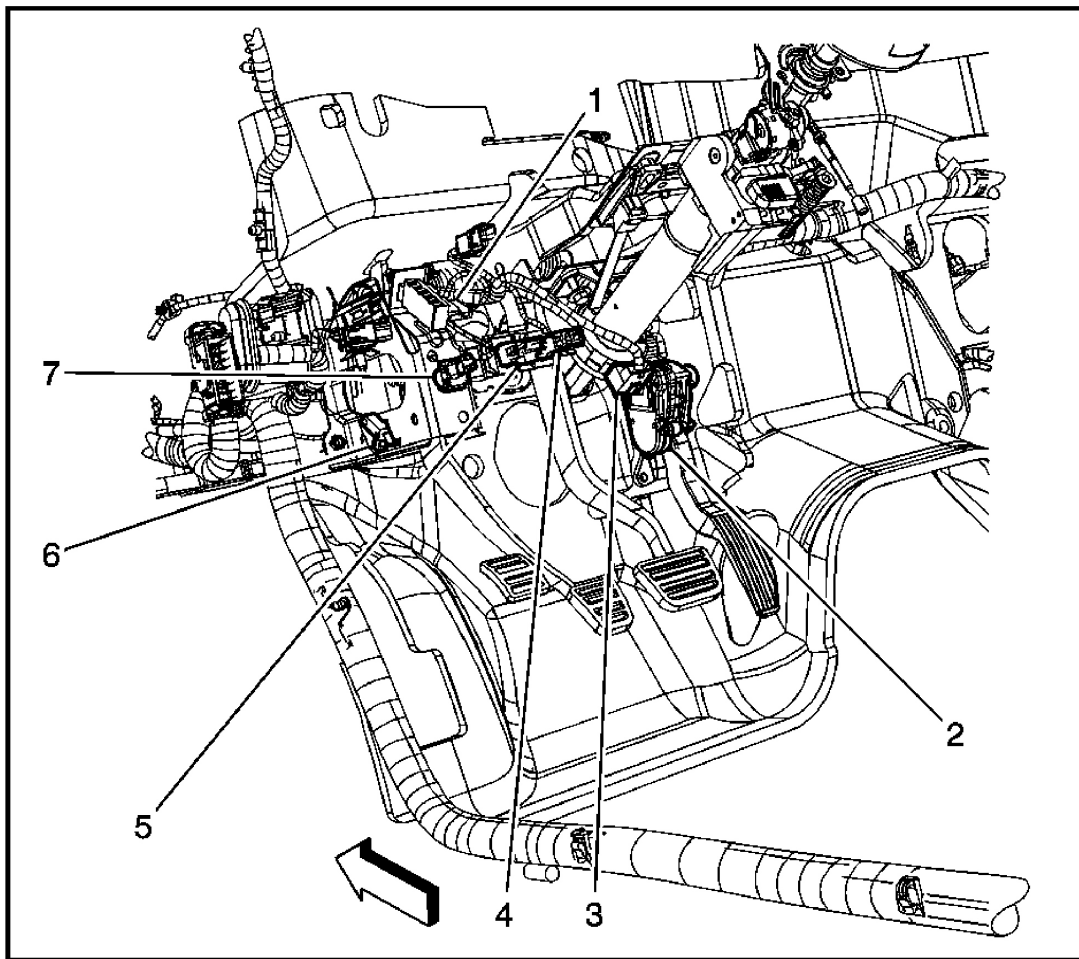
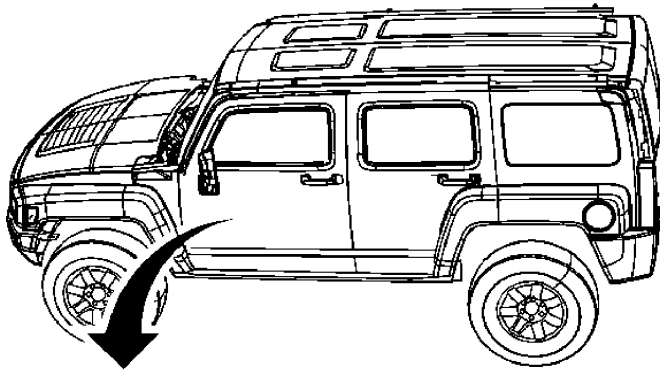

Fig. 8: View Of Components On Lower Left Side Of I/P
Courtesy of GENERAL MOTORS CORP.

Callouts For Fig. 8

Callout	Component Name
1	Clutch Start Switch (MA5)

2007 Hummer H3

2007 BRAKES Antilock Brake System - H3

2	Accelerator Pedal Position (APP) Sensor
3	Steering Wheel Position Sensor (JL4)
4	TCC Brake/Cruise Release Switch
5	Stop Lamp Switch
6	Park Brake Switch
7	Clutch Release Switch (MA5)

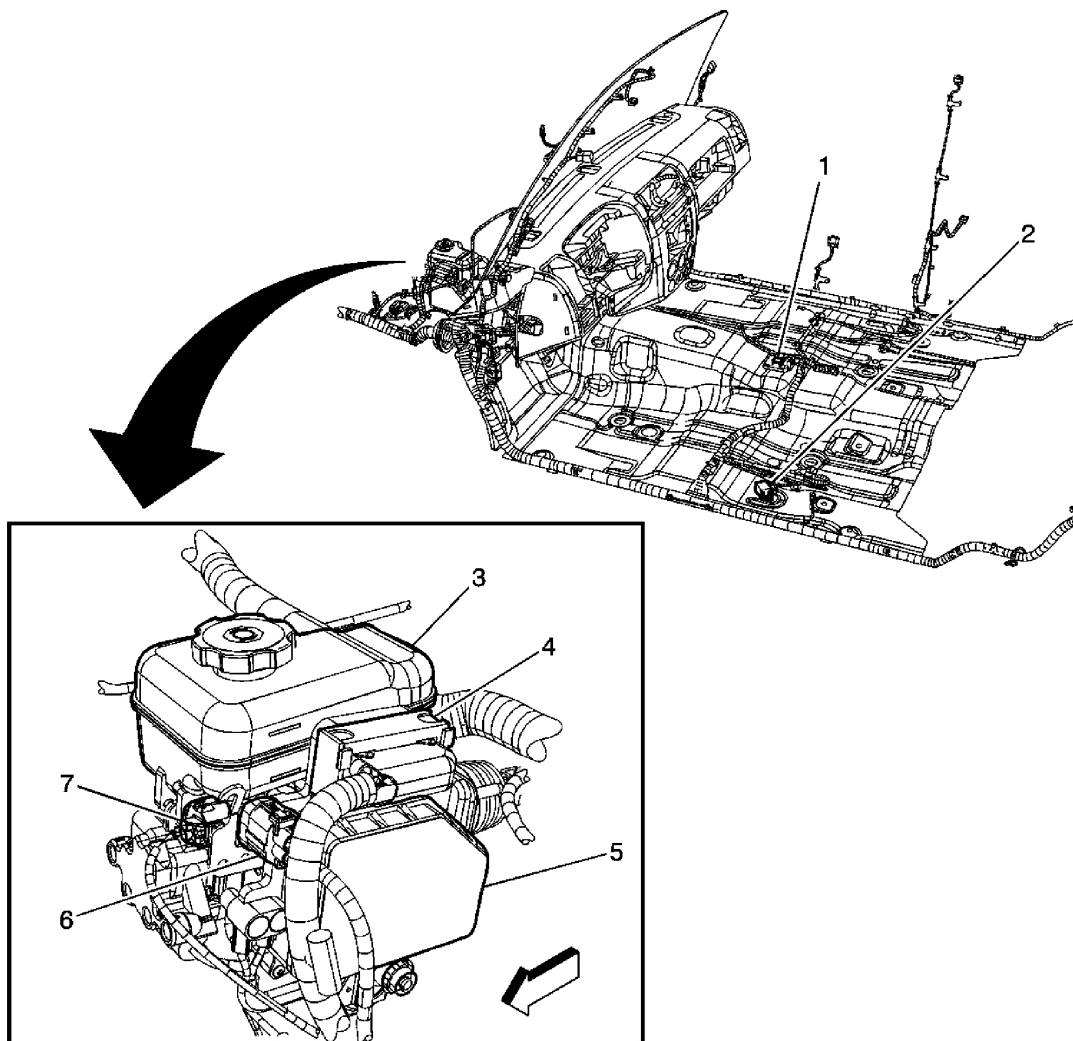

Fig. 9: Locating Brake Components
 Courtesy of GENERAL MOTORS CORP.

Callouts For Fig. 9

Callout	Component Name
---------	----------------

2007 Hummer H3

2007 BRAKES Antilock Brake System - H3

1	Inflatable Restraint Vehicle Rollover Sensor (ASF)
2	Yaw Rate/Lateral and Longitudinal Accelerometer Sensor (JL4)
3	Brake Fluid Reservoir
4	Electronic Brake Control Module (EBCM) C2
5	Electronic Brake Control Module (EBCM)
6	Electronic Brake Control Module (EBCM) C1
7	Brake Fluid Level Switch

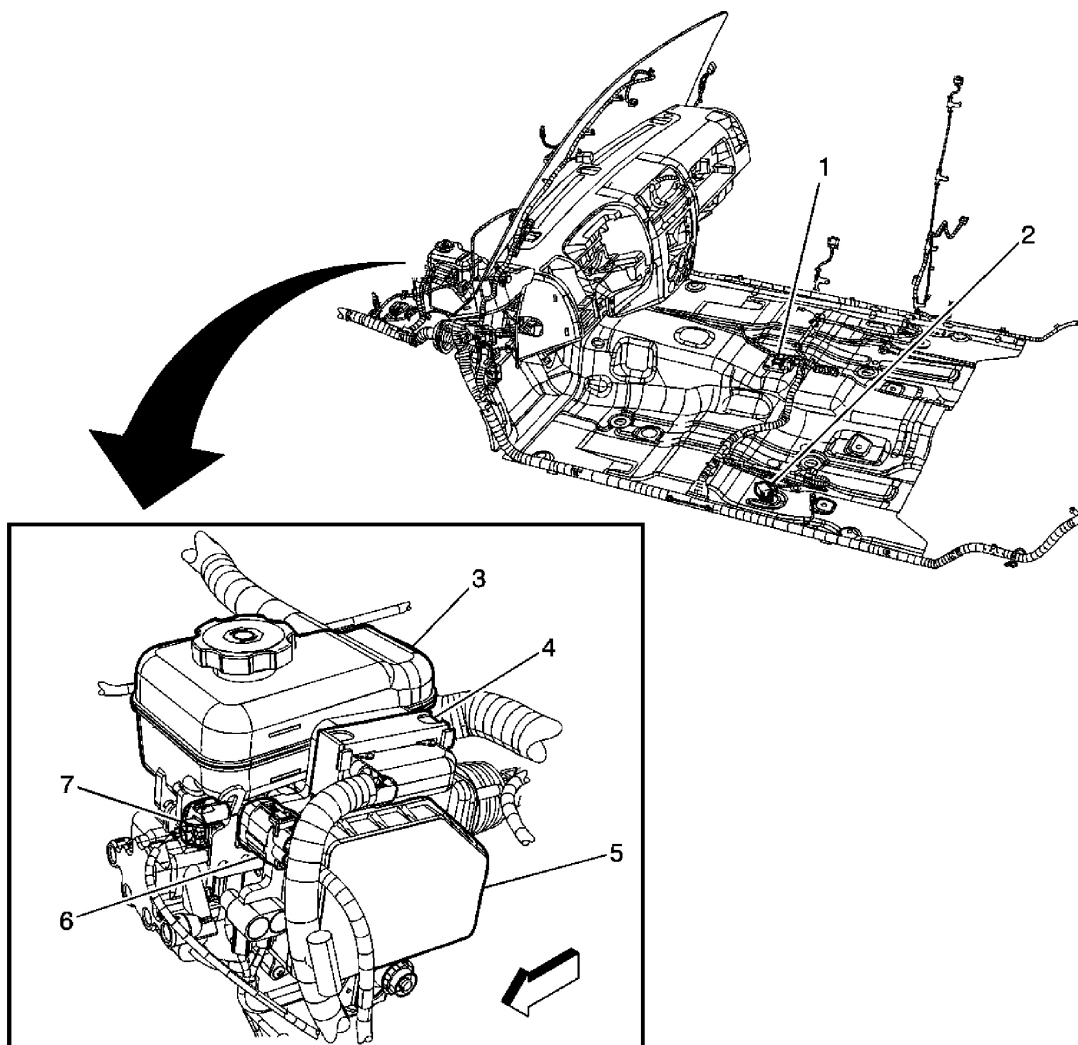

Fig. 10: Locating Brake Components (w/o JL4)
Courtesy of GENERAL MOTORS CORP.

Callouts For Fig. 10

2007 Hummer H3

2007 BRAKES Antilock Brake System - H3

Callout	Component Name
1	Inflatable Restraint Rollover Sensor
2	Longitudinal Accelerometer Sensor (w/o JL4)
3	Brake Fluid Reservoir
4	Electronic Brake Control Module (EBCM) C2
5	Electronic Brake Control Module (EBCM)
6	Electronic Brake Control Module (EBCM) C1
7	Brake Fluid Level Switch

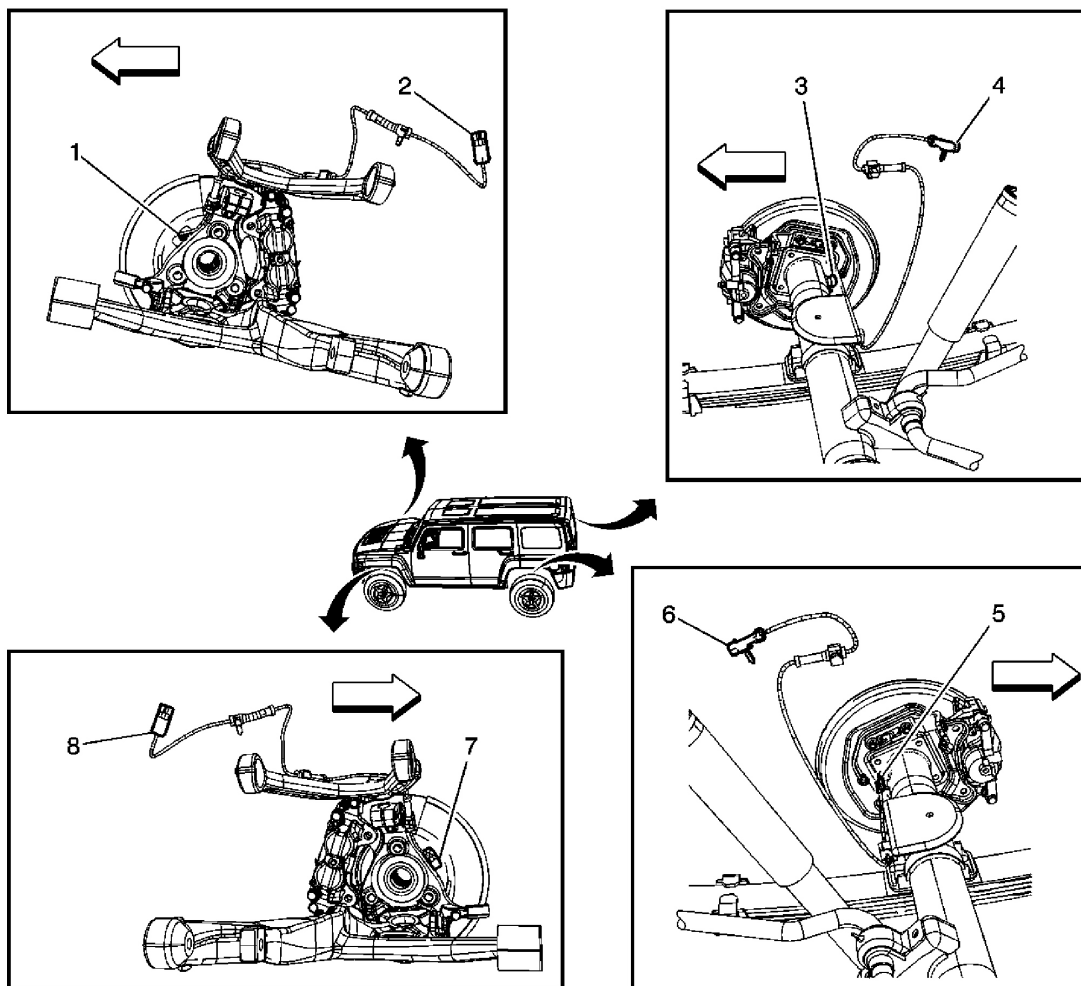

Fig. 11: Locating Wheel Speed Sensors
 Courtesy of GENERAL MOTORS CORP.

Callouts For Fig. 11

--	--

2007 Hummer H3

2007 BRAKES Antilock Brake System - H3

Callout	Component Name
1	Wheel Speed Sensor (WSS) - RF
2	Wheel Speed Sensor (WSS) - RF Connector
3	Wheel Speed Sensor (WSS) - RR
4	Wheel Speed Sensor (WSS) - RR Connector
5	Wheel Speed Sensor (WSS) - LR
6	Wheel Speed Sensor (WSS) - LR Connector
7	Wheel Speed Sensor (WSS) - LF
8	Wheel Speed Sensor (WSS) - LF Connector

ANTILOCK BRAKE SYSTEM CONNECTOR END VIEWS

Accessory Switch

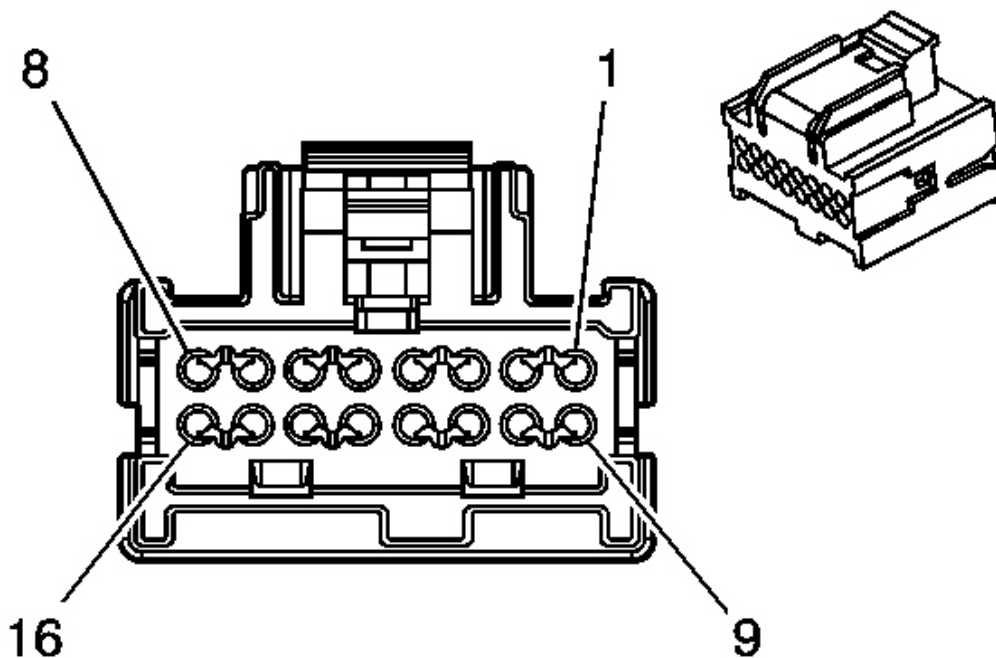

Fig. 12: Accessory Switch Connector End View
Courtesy of GENERAL MOTORS CORP.

2007 Hummer H3

2007 BRAKES Antilock Brake System - H3

Accessory Switch Connector Parts Information

Connector Part Information

- OEM: 15394150
- Service: See Catalog
- Description: 16-Way F Micro 64 Series (BK)

Terminal Part Information

- Terminal/Tray: 15359541/4
- Core/Insulation Crimp: M/M
- Release Tool/Test Probe: 15381651-2/J-35616-64A (L-BU)

Accessory Switch Connector Terminal Identification

Pin	Wire Color	Circuit No.	Function
1	PU/WH	1565	4 LO LOCK Indicator Control
2	YE	234	Seat Belt Indicator Control
3	D-BU	2307	Passenger Air Bag On Indicator Control
4	-	-	Not Used
5	YE	1139	Ignition 1 Voltage
6	D-GN	2308	Passenger Air Bag Off Indicator Control
7	BN	241	Ignition 3 Voltage
8	PK	1561	Differential Lock Indicator Control
9	TN/BK	1566	4 HI LOCK Indicator Control
10	BN	1560	Neutral Indicator Control
11	L-GN/BK	1563	4 HI Indicator Control
12	GY	8	Instrument Panel Lamps Dimmer Switch Signal
13	BK	2050	Ground
14	BN/WH	1571	Traction Control Switch Signal
15	L-BU	1693	Switch Signal
16	GY	596	5V

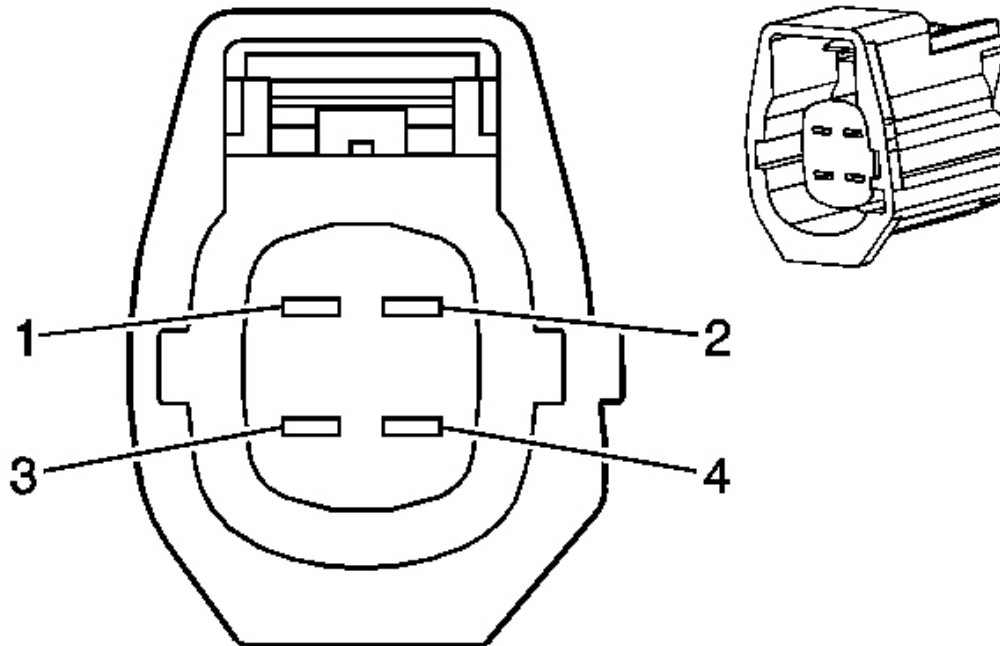

Fig. 13: Electronic Brake Control Module (EBCM) C1 Connector End View
Courtesy of GENERAL MOTORS CORP.

Electronic Brake Control Module (EBCM) C1 Connector Parts Information

Connector Part Information

- OEM: 6189-1048
- Service: See Catalog
- Description: 4-Way F 025/187 Sealed (BK)

Terminal Part Information

- Pins: 1
- Terminal/Tray: 8100-3455/22
- Core/Insulation Crimp: 7/7
- Release Tool/Test Probe: 15315247/J-35616-64A (L-BU)

- Pins: 3, 4

2007 Hummer H3

2007 BRAKES Antilock Brake System - H3

- Terminal/Tray: 8100-0468/6
- Core/Insulation Crimp: F/5
- Release Tool/Test Probe: 12094430/J-35616-40 (BU)

Electronic Brake Control Module (EBCM) C1 Connector Terminal Identification

Pin	Wire Color	Circuit No.	Function
1	PK	1439	Ignition 1 Voltage
2	OG	540	Battery Positive Voltage
3	-	-	Not Used
4	BK	850	Ground (LHD)
	BK	2050	Ground (RHD)

Electronic Brake Control Module (EBCM) C2

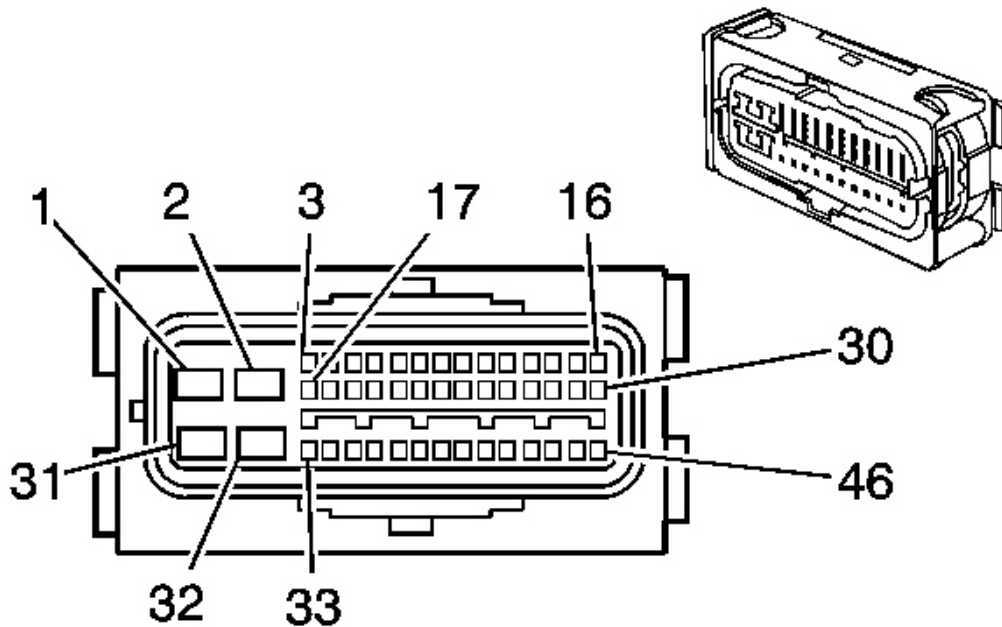

Fig. 14: Electronic Brake Control Module (EBCM) C2 Connector End View
Courtesy of GENERAL MOTORS CORP.

Electronic Brake Control Module (EBCM) C2 Connector Parts Information

2007 Hummer H3

2007 BRAKES Antilock Brake System - H3

Connector Part Information

- OEM: 6189-1136
- Service: See Catalog
- Description: 46-Way F 025/187 Sealed (BK)

Terminal Part Information

- Pins: 1, 2, 31, 32
- Terminal/Tray: 8100-0468/6
- Core/Insulation Crimp: F/5
- Release Tool/Test Probe: 12094430/J-35616-40 (BU)

- Pins: 3-27, 38-46
- Terminal/Tray: 8100-3455/22
- Core/Insulation Crimp: Pins 3-6, 9-10, 17-20, 42, 45: 8/8
- Core/Insulation Crimp: Pins 8, 11, 22-27, 38-41, 43-44, 46: 7/7
- Release Tool/Test Probe: 15315247/J-35616-64A (L-BU)

Electronic Brake Control Module (EBCM) C2 Connector Terminal Identification

Pin	Wire Color	Circuit No.	Function
1	BK	850	Ground
2	OG	540	Battery Positive Voltage
3	D-GN	872	Right Front Wheel Speed Sensor Signal
4	YE	873	Left Front Wheel Speed Sensor Low Reference
5	BN	882	Right Rear Wheel Speed Sensor Signal
6	RD	885	Left Rear Wheel Speed Sensor Low Reference
7	-	-	Not Used
8	WH	1765	Steering Wheel Position Marker Pulse Signal (JL4)
9	OG/BK	463	Requested Torque Signal
10	TN/BK	464	Delivered Torque Signal
11	D-BU	716	CAN HI (JL4)
12-16	-	-	Not Used

2007 Hummer H3

2007 BRAKES Antilock Brake System - H3

17	TN	833	Right Front Wheel Speed Sensor Low Reference
18	L-BU	830	Left Front Wheel Speed Sensor Signal
19	WH	883	Right Rear Wheel Speed Sensor Low Reference
20	BK	884	Left Rear Wheel Speed Sensor Signal
21	-	-	Not Used
22	L-BU	1764	Steering Wheel Position Signal B (JL4)
23	L-GN	1763	Steering Wheel Position Signal A (JL4)
24	-	-	Not Used
25	L-BU	2088	CAN LO (JL4)
26	-	-	Not Used
27	PK	849	Brake Fluid Level Sensor Signal
28-30	-	-	Not Used
31	OG	2340	Battery Positive Voltage
32	BK	850	Ground (LHD)
	BK	2050	Ground (RHD)
33-37	-	-	Not Used
38	BK	1835	Low Reference (JL4)
	L-BU	2088	Low Reference (w/o JL4)
39	L-BU	1059	Steering Wheel Position Sensor Signal (JL4)
40	GY	1056	Steering Wheel Position Sensor 5V (JL4)
	D-GN	2087	5V (w/o JL4)
41	YE	5353	Longitudinal Accelerometer Sensor Signal (w/o JL4)
42	L-GN	24	Backup Lamp Supply Voltage
43	-	-	Not Used
44	PU	1807	Class 2 Serial Data
45	L-BU	20	Stop Lamp Supply Voltage
46	BN	441	Ignition 3 Voltage

Longitudinal Accelerometer Sensor (w/o JL4)

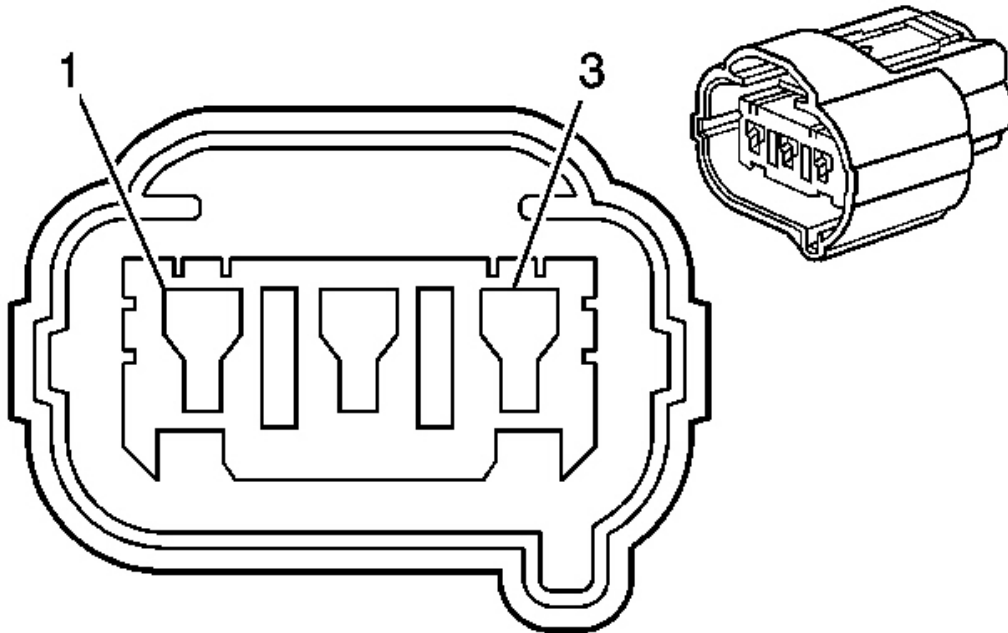

Fig. 15: Input/Output Speed Sensor Connector End View (w/o JL4)
 Courtesy of GENERAL MOTORS CORP.

Longitudinal Accelerometer Sensor (w/o JL4) Connector Parts Information

Connector Part Information

- OEM: 6189-0099
- Service: See Catalog
- Description: 3-Way F HX 090 Series (BK)

Terminal Part Information

- Terminal/Tray: 8100-0460/6
- Core/Insulation Crimp: E/1
- Release Tool/Test Probe: 15315247/J-35616-2A (GY)

Longitudinal Accelerometer Sensor (w/o JL4) Connector Terminal Identification

Pin	Wire Color	Circuit No.	Function
			Longitudinal Accelerometer Sensor

2007 Hummer H3

2007 BRAKES Antilock Brake System - H3

1	YE	5353	Signal
2	L-BU	2088	Low Reference
3	D-GN	2087	5V

Steering Wheel Position Sensor (JL4)

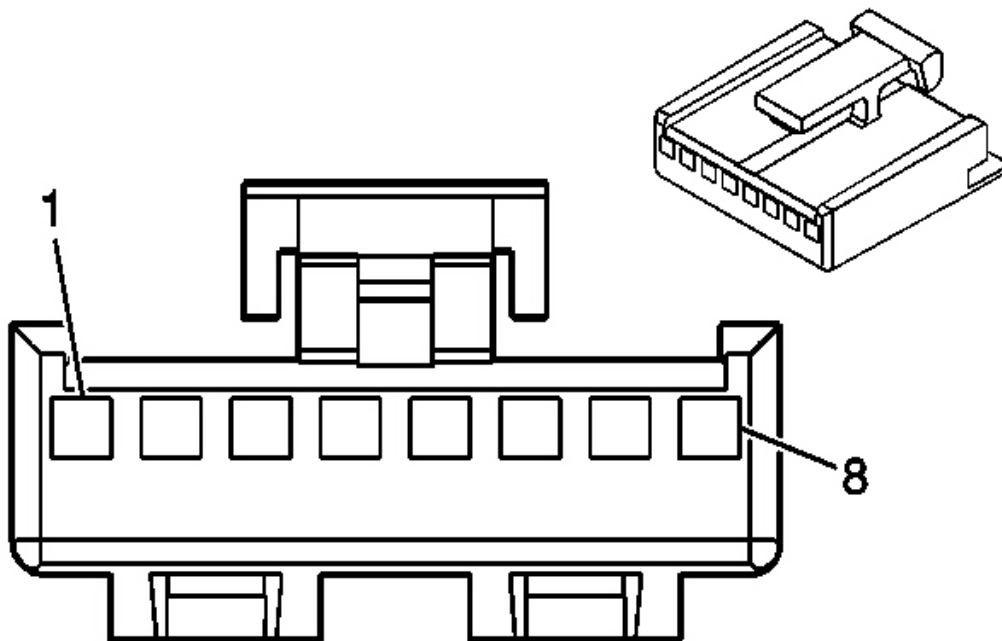

Fig. 16: Steering Wheel Position Sensor (JL4) Connector End View
Courtesy of GENERAL MOTORS CORP.

Steering Wheel Position Sensor (JL4) Connector Parts Information

Connector Part Information

- OEM: 12052444
- Service: 12101874
- Description: 8-Way F Micro-Pack 100 Series (BK)

Terminal Part Information

- Terminal/Tray: 12089660/3

2007 Hummer H3

2007 BRAKES Antilock Brake System - H3

- Core/Insulation Crimp: See Terminal Kit
- Release Tool/Test Probe: See Terminal Kit

Steering Wheel Position Sensor (JL4) Connector Terminal Identification

Pin	Wire Color	Circuit No.	Function
1	GY	1056	Steering Wheel Position Sensor 5V
2	BK	1835	Low Reference
3	L-GN	1763	Steering Wheel Position Signal A
4	L-BU	1764	Steering Wheel Position Signal B
5	WH	1765	Steering Wheel Position Marker Pulse Signal
6	L-BU	1059	Steering Wheel Position Sensor Signal
7	BN	441	Ignition 3 Voltage
8	BK/WH	1151	Ground

Wheel Speed Sensor (WSS) - Left Front

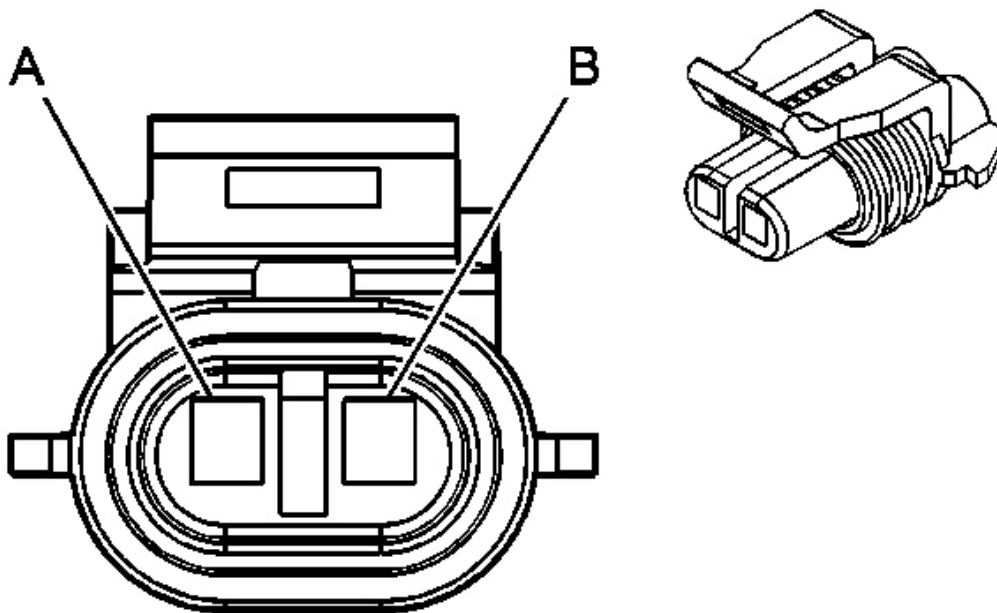

Fig. 17: Wheel Speed Sensor (WSS) - Left Front Connector End View

2007 Hummer H3

2007 BRAKES Antilock Brake System - H3

Courtesy of **GENERAL MOTORS CORP.**

Wheel Speed Sensor (WSS) - Left Front Connector Parts Information

Connector Part Information

- OEM: 12052641
- Service: 12102747
- Description: 2-Way F Metri-Pack 150 Series Sealed (BK)

Terminal Part Information

- Terminal/Tray: 12048074/2
- Core/Insulation Crimp: E/1
- Release Tool/Test Probe: 12094429/J-35616-2A (GY)

Wheel Speed Sensor (WSS) - Left Front Connector Terminal Identification

Pin	Wire Color	Circuit No.	Function
A	YE	873	Left Front Wheel Speed Sensor Low Reference
B	L-BU	830	Left Front Wheel Speed Sensor Signal

Wheel Speed Sensor (WSS) - Left Rear

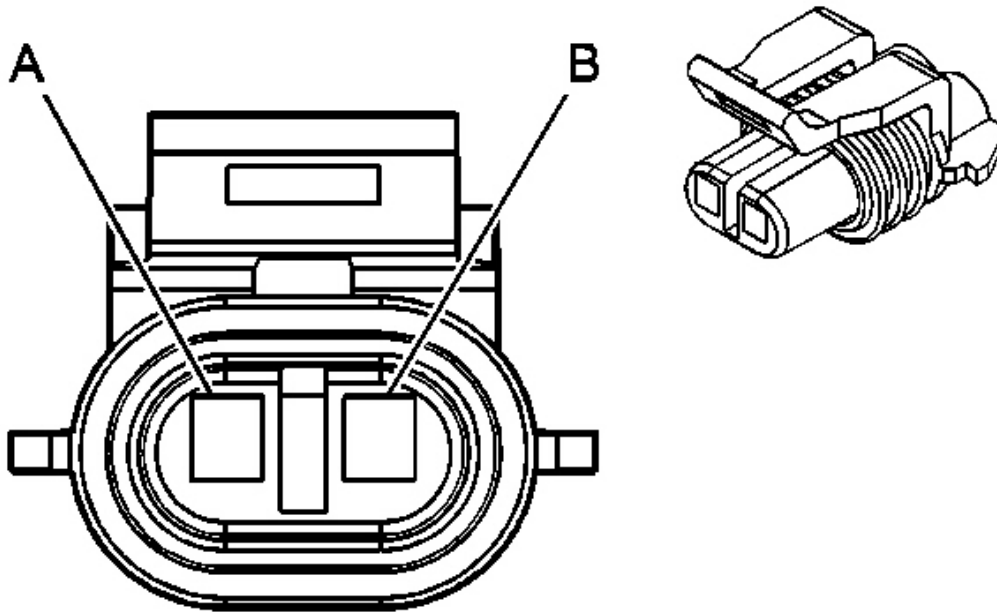

Fig. 18: Wheel Speed Sensor (WSS) - Left Rear Connector End View
 Courtesy of GENERAL MOTORS CORP.

Wheel Speed Sensor (WSS) - Left Rear Connector Parts Information

Connector Part Information

- OEM: 12052641
- Service: 12102747
- Description: 2-Way F Metri-Pack 150 Series Sealed (BK)

Terminal Part Information

- Terminal/Tray: 12048074/2
- Core/Insulation Crimp: E/1
- Release Tool/Test Probe: 12094429/J-35616-2A (GY)

Wheel Speed Sensor (WSS) - Left Rear Connector Terminal Identification

Pin	Wire Color	Circuit No.	Function
			Left Rear Wheel Speed Sensor Low

2007 Hummer H3

2007 BRAKES Antilock Brake System - H3

A	RD	885	Reference
B	BK	884	Left Rear Wheel Speed Sensor Signal

Wheel Speed Sensor (WSS) - Right Front

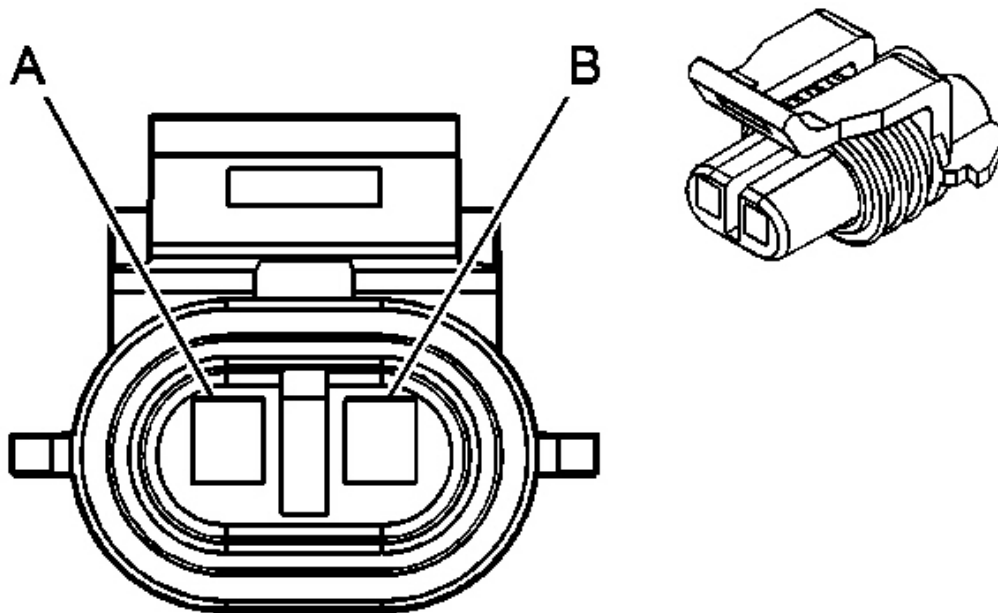

Fig. 19: Wheel Speed Sensor (WSS) - Right Front Connector End View
Courtesy of GENERAL MOTORS CORP.

Wheel Speed Sensor (WSS) - Right Front Connector Parts Information

Connector Part Information

- OEM: 12052641
- Service: 12102747
- Description: 2-Way F Metri-Pack 150 Series Sealed (BK)

Terminal Part Information

- Terminal/Tray: 12048074/2
- Core/Insulation Crimp: E/1

2007 Hummer H3

2007 BRAKES Antilock Brake System - H3

- Release Tool/Test Probe: 12094429/J-35616-2A (GY)

Wheel Speed Sensor (WSS) - Right Front Connector Terminal Identification

Pin	Wire Color	Circuit No.	Function
A	TN	833	Right Front Wheel Speed Sensor Low Reference
B	D-GN	872	Right Front Wheel Speed Sensor Signal

Wheel Speed Sensor (WSS) - Right Rear

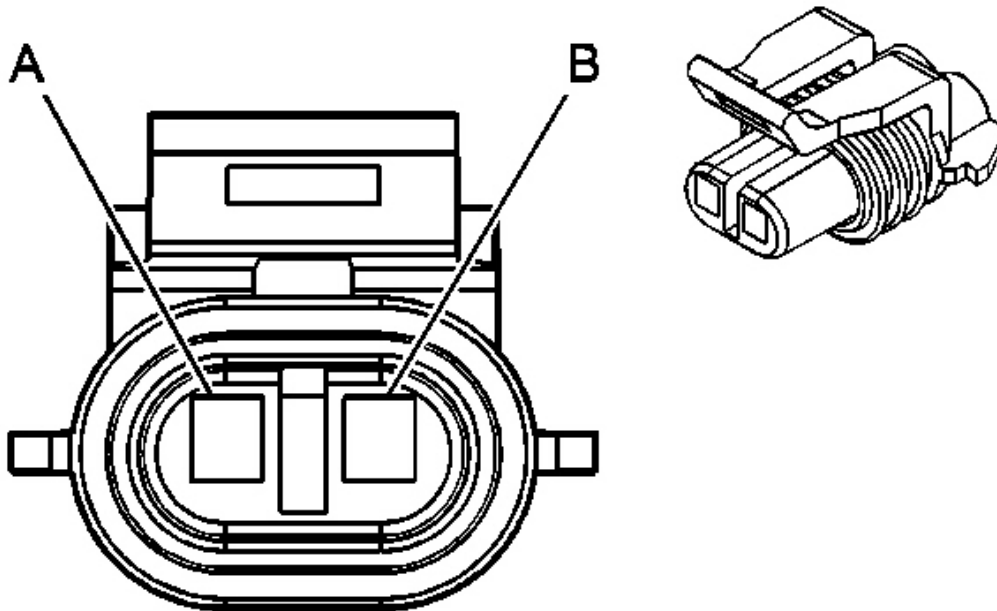

Fig. 20: Wheel Speed Sensor (WSS) - Right Rear Connector End View
Courtesy of GENERAL MOTORS CORP.

Wheel Speed Sensor (WSS) - Right Rear Connector Parts Information

Connector Part Information

- OEM: 12052641

2007 Hummer H3

2007 BRAKES Antilock Brake System - H3

- Service: 12102747
- Description: 2-Way F Metri-Pack 150 Series Sealed (BK)

Terminal Part Information

- Terminal/Tray: 12048074/2
- Core/Insulation Crimp: E/1
- Release Tool/Test Probe: 12094429/J-35616-2A (GY)

Wheel Speed Sensor (WSS) - Right Rear Connector Terminal Identification

Pin	Wire Color	Circuit No.	Function
A	WH	883	Right Rear Wheel Speed Sensor Low Reference
B	BN	882	Right Rear Wheel Speed Sensor Signal

Yaw Rate/Lateral and Longitudinal Accelerometer Sensor (JL4)

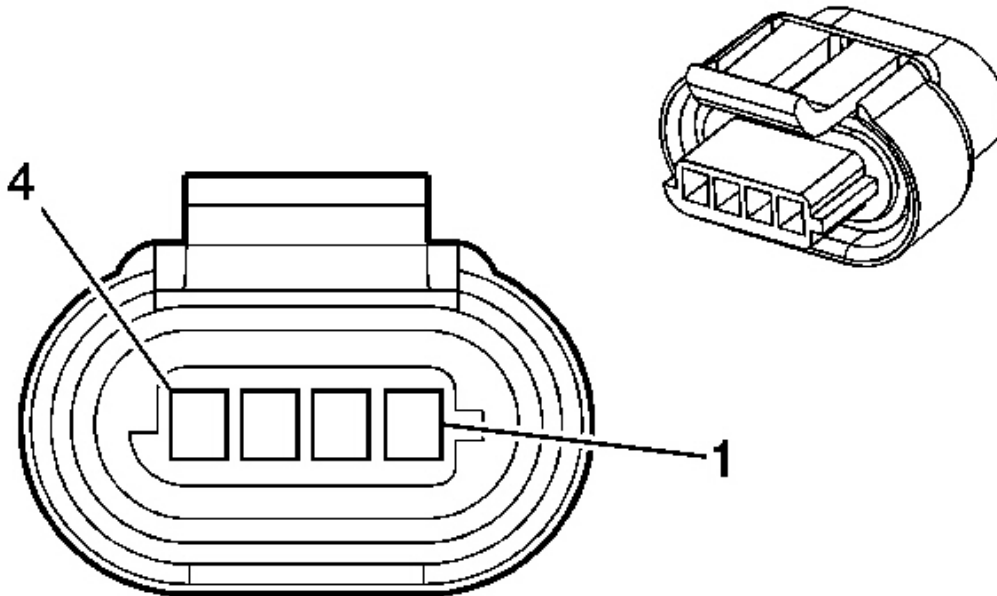

Fig. 21: Yaw Rate/Lateral and Longitudinal Accelerometer Sensor (JL4 Connector End View)

2007 Hummer H3

2007 BRAKES Antilock Brake System - H3

Courtesy of GENERAL MOTORS CORP.

Yaw Rate/Lateral and Longitudinal Accelerometer Sensor (JL4) Connector Parts Information

Connector Part Information

- OEM: 6189-0551
- Service: 15165777
- Description: 4-Way F DL 040 Sealed (WH)

Terminal Part Information

- Terminal/Tray: 8100-1466/6
- Core/Insulation Crimp: 7/7
- Release Tool/Test Probe: 15315247/J-35616-64A (L-BU)

Yaw Rate/Lateral and Longitudinal Accelerometer Sensor (JL4) Connector Terminal Identification

Pin	Wire Color	Circuit No.	Function
1	BN	441	Ignition 3 Voltage
2	D-BU	716	CAN HI
3	L-BU	2088	CAN LO
4	BK/WH	1151	Ground

DIAGNOSTIC INFORMATION AND PROCEDURES

DIAGNOSTIC CODE INDEX

DIAGNOSTIC CODE INDEX

DTC	Description
<u>DTC B0010</u>	Reverse Gear Signal Circuit
<u>DTC B2745</u>	Traction Control Switch Circuit
<u>DTC C0035-C0050</u>	Wheel Speed Sensor Circuit
<u>DTC C0110</u>	Pump Motor Circuit
<u>DTC C0131</u>	Antilock Brake System (ABS) Pressure Circuit
<u>DTC C0136</u>	Base Brake System Pressure Circuit
<u>DTC C0161</u>	ABS Brake Switch Circuit
<u>DTC C0179</u>	System Thermal High

2007 Hummer H3

2007 BRAKES Antilock Brake System - H3

<u>DTC C0186 or C0196</u>	Lateral Accelerometer/Yaw Rate Circuit
<u>DTC C0191</u>	Four Wheel Drive (4WD) Reference Accelerometer Circuit
<u>DTC C0201</u>	Antilock Brake System (ABS) Enable Relay Contact Circuit
<u>DTC C0240 or P0856</u>	PCM Traction Control Not Allowed/Traction Control Torque Request Circuit
<u>DTC C0244 or P1689</u>	Pulse Width Modulated (PWM) Delivered Torque/Traction Control Delivered Torque Output Circuit
<u>DTC C0245</u>	Wheel Speed Sensor Frequency Error
<u>DTC C0268</u>	Class 2 Data Error Reported
<u>DTC C0276</u>	Transmission Control Module (TCM) Traction Control Not Allowed
<u>DTC C0550</u>	Electronic Control Unit (ECU) Performance
<u>DTC C0710</u>	Steering Position Signal
<u>DTC U1651</u>	Chassis System Dedicated Bus Sensor 1 Malfunction

DIAGNOSTIC STARTING POINT - ANTILOCK BRAKE SYSTEM

Begin the system diagnosis with **Diagnostic System Check - Vehicle** . The diagnostic system check - vehicle will provide the following information:

- The identification of the control modules which command the system
- The ability of the control modules to communicate through the serial data circuit
- The identification of any stored diagnostic trouble codes (DTCs) and their status

The use of the diagnostic system check - vehicle will identify the correct procedure for diagnosing the system and where the procedure is located.

SCAN TOOL OUTPUT CONTROLS

Scan Tool Output Controls

Scan Tool Output Control	Additional Menu Selections	Description
Refer to the scan tool manual for complete scan tool operating instructions.		
ABS Motor	-	This function allows the technician to command the ABS pump motor On and Off.
		This function allows the technician to command a selected valve solenoid On and Off. Use the procedures below to verify proper operation of the

2007 Hummer H3

2007 BRAKES Antilock Brake System - H3

Solenoid Tests	<ul style="list-style-type: none"> • Left Front Isolation Valve • Left Front Dump Valve • Right Front Isolation Valve • Right Front Dump Valve • Rear Isolation Valve • Rear Dump Valve 	<p>EBCM and BPMV.</p> <p>Dump Valve Solenoid Test Procedure</p> <ol style="list-style-type: none"> 1. Apply the parking brake fully. 2. Start the engine and allow the engine to idle. 3. Select the desired Dump Valve Solenoid Test on the scan tool. 4. Apply the brake and maintain steady pressure on the brake pedal. 5. Command the solenoid On and verify that the brake pedal drops to the floor. <p>Isolation Valve Solenoid Test Procedure</p> <ol style="list-style-type: none"> 1. Apply the parking brake fully. 2. Start the engine and allow the engine to idle. 3. Select the desired Isolation Valve Solenoid Test on the scan tool. 4. Apply the brake with very light pressure only enough to close the brake switch. 5. Command the solenoid On and then immediately apply firm and steady pressure to the brake pedal. 6. The EBCM automatically de-energizes the solenoid after about 3 seconds. When this occurs, verify that the brake pedal drops about 2.2 cm (1 inch).
----------------	---	---

SCAN TOOL DATA LIST

Scan Tool Data List

Scan Tool Parameter	Data List	Units Displayed	Typical Data Value
Ignition ON, Engine OFF and Brake Released			
4WD Status	ABS	Two wheel drive/Four wheel drive	4WD
ABS Active	ABS/VSES	Yes/No	No

2007 Hummer H3

2007 BRAKES Antilock Brake System - H3

ABS Lamp Command	ABS/VSES	On/Off	Off
ABS Pump Motor	ABS/VSES	On/Off	Off
ABS Relay Command	ABS/VSES	On/Off	ON
ABS Stop State	VSES	On/Off	Off
Accum. Pressure Sensor	ABS/VSES	MPa/psi	Varies
Analog Steering Position Sensor	VSES	°	Varies
Battery Voltage	ABS	Volts	12.0 Volts
Brake Fluid Level	ABS/VSES	OK/Low	OK
Brake Switch Status	ABS/VSES	On/Off	Off
Brake Warning Lamp Command	VSES	On/Off	Off
Delivered Torque	ABS	%	Varies
Digital Steering Position Sensor	VSES	°	Varies
Lateral Accelerometer Input	VSES	m/s -ft/s	0
Left Front Wheel Speed	ABS	km/h or mph	0 km/h/0 mph
Left Rear Wheel Speed	ABS	km/h or mph	0 km/h/0 mph
LF Dump Valve Command	ABS/VSES	On/Off	Off
LF Iso. Valve Command	ABS/VSES	On/Off	Off
LR Dump Valve Command	ABS/VSES	On/Off	Off
LR Iso. Valve Command	ABS/VSES	On/Off	Off
Longitudinal Accelerometer Sensor Signal	ABS	m/s ² or ft/s ²	Varies
Master Cylinder Pressure Sensor Input	ABS/VSES	kPa or Psi	0
Requested Torque	ABS	%	90%
Reverse Switch	ABS/VSES	On/Off	Off
RF Dump Valve Command	ABS/VSES	On/Off	Off
RF Iso. Valve Command	ABS/VSES	On/Off	Off
RR Dump Valve Command	ABS/VSES	On/Off	Off
RR Iso. Valve Command	ABS/VSES	On/Off	Off
RF Dump Valve Command	ABS/VSES	On/Off	Off
RF ISO Valve Command	ABS/VSES	On/Off	Off
Right Front Wheel Speed	ABS	km/h or mph	0 km/h/0 mph

2007 Hummer H3

2007 BRAKES Antilock Brake System - H3

Right Rear Wheel Speed	ABS	km/h or mph	0 km/h/0 mph
Stability System Active	VSES	Yes/No	No
Stability System Enabled	VSES	Yes/No	Yes
System Configuration	ABS/VSES	Invalid/Not Determined/Non-VSES Auto/Non-VSES Manual/VSES	Varies
System Voltage	VSES	Volts	12 V
TCS Status/EBCM - TCS Active	ABS/VSES	Yes/No	No
TCS Status/PCM - TCS Active	ABS/VSES	Yes/No	No
Traction Control Equipped	ABS	Invalid/Disabled/Enabled or N/A	Enabled
Traction Control Switch	ABS	Yes/No	Yes
Transmission Type	ABS/VSES	Invalid/Not Determined/Automatic/Manual	Varies
VSES Control Switch	VSES	Invalid/Disabled/Enabled or N/A	Enabled
VSES Equipped	VSES	Yes/No	Varies
Yaw Rate Sensor Input	VSES	°/sec	0

SCAN TOOL DATA DEFINITIONS

The ABS scan tool data definitions contain a brief description of all ABS related parameters available on the scan tool. The parameters available on the scan tool are listed below in alphanumeric order.

4WD Status

The scan tool displays if the vehicle is in 2 wheel drive or 4 wheel drive.

ABS Active

The scan tool displays if the ABS system is performing antilock braking.

ABS Lamp Command

The scan tool displays the commanded state of the ABS warning indicator.

ABS Pump Motor

The scan tool displays On/Off. The scan tool displays On when the ABS pump motor is commanded on.

ABS Relay Command

The scan tool displays the commanded state of the ABS system relay.

ABS Stop State

The scan tool displays if the ABS system is performing antilock braking.

Accum. Pressure Sensor

The scan tool displays brake fluid pressure stored in the accumulator.

Analog Steering Position Sensor

The scan tool displays the analog steering position angle in degrees.

Battery Voltage

The scan tool displays the approximate voltage supplied by the battery and charging system.

Brake Fluid Level

The scan tool displays if the brake fluid is Low or OK.

Brake Switch Status

The scan tool displays the state of the brake switch.

Brake Warning Lamp Command

The scan tool displays ON when the EBCM requests illumination of the brake warning indicator.

Delivered Torque

The scan tool displays between 11% and 90%. The PCM provides the percentage of engine torque that is currently applied to the wheels. The lower the percentage the less torque

applied to the wheels.

Digital Steering Position Sensor

The scan tool displays the digital steering position angle in degrees.

Lateral Accelerometer Input

The scan tool displays the sideways acceleration of the vehicle in meters per second (m/s) or feet per second (ft/s).

Left Front Wheel Speed

The scan tool displays the actual speed of the left front wheel.

Left Rear Wheel Speed

The scan tool displays the actual speed of the left rear wheel.

LF Dump Valve Command

The scan tool displays the commanded state of the left front dump valve solenoid.

LF Iso. Valve Command

The scan tool displays the commanded state of the left front isolation valve solenoid.

LR Dump Valve Command

The scan tool displays the commanded state of the left rear dump valve solenoid.

LR Iso. Valve Command

The scan tool displays the commanded state of the left front isolation valve solenoid.

Longitudinal Accelerometer Sensor Signal

The scan tool displays the longitudinal accelerometer sensor signal voltage.

Master Cylinder Pressure Sensor Input

The scan tool displays the hydraulic brake pressure applied by the master cylinder.

Requested Torque

The scan tool displays between 11% and 90%. The PCM provides the percentage of engine torque that is currently applied to the wheels. The lower the percentage the less torque applied to the wheels.

Reverse Switch

The scan tool displays ON when the transmission gear selector is in reverse.

Right Front Wheel Speed

The scan tool displays the actual speed of the left front wheel.

Right Rear Wheel Speed

The scan tool displays the actual speed of the left rear wheel.

RF Dump Valve Command

The scan tool displays the commanded state of the left front dump valve solenoid.

RF Dump Valve Command

The scan tool displays On/Off. The scan tool displays On when the right front dump valve solenoid is commanded on.

RF Iso. Valve Command

The scan tool displays the commanded state of the left front isolation valve solenoid.

RR Dump Valve Command

The scan tool displays the commanded state of the left rear dump valve solenoid.

RR Iso. Valve Command

The scan tool displays the commanded state of the left front isolation valve solenoid.

Stability System Active

The scan tool displays the active status of the vehicle stability enhancement system (VSES).

Stability System Enabled

The scan tool displays the operating status of the VSES.

System Configuration

The scan tool displays the configuration of the EBCM.

System Voltage

The scan tool displays the approximate voltage supplied by the battery and charging system.

TCS Status/EBCM -TCS Active

The scan tool displays Yes if the EBCM is requesting torque reduction from the PCM.

TCS Status/PCM -TCS Active

The scan tool displays Yes if the PCM is reducing engine torque during a traction control event.

Traction Control Equipped

The scan tool displays if the vehicle is equipped with traction control.

Traction Control Switch

The scan tool displays the status of the traction control switch that is reported by the BCM.

Transmission Type

The scan tool displays whether the vehicle is equipped with a manual or automatic transmission.

VSES Control Switch

The scan tool displays if the enabled/disabled status of the VSES system requested by the BCM/traction switch. VSES can be disabled by use of the traction switch.

VSES Equipped

The scan tool displays if the vehicle is equipped with VSES.

Yaw Rate Sensor Input

The scan tool displays the degrees of vehicle rotation (yaw rate) per second.

DTC B0010

Diagnostic Instructions

- Perform the **Diagnostic System Check - Vehicle** prior to using this diagnostic procedure.
- Review **Strategy Based Diagnosis** for an overview of the diagnostic approach.
- **Diagnostic Procedure Instructions** provides an overview of each diagnostic category.

DTC Descriptor

DTC B0010

Reverse Gear Signal Circuit

Diagnostic Fault Information

DTC B0010

Circuit	Short to Ground	Open/High Resistance	Short to Voltage	Signal Performance
Backup Lamp Supply Voltage	-	B0010	1	-
1. Reverse lamp always illuminated				

Circuit/System Description

The electronic brake module (EBCM) receives a 12-volt signal from the backup lamp supply voltage circuit when the vehicle transmission is in reverse. The EBCM uses the backup lamp supply voltage circuit to perform traction control and vehicle stability in reverse.

Conditions for Running the DTC

- The ignition is ON.
- The vehicle speed is greater than 15 km/h (9 mph) for 2 seconds continuously.
- The vehicle is equipped with a manual transmission.

Conditions for Setting the DTC

The EBCM detects an open in the backup lamp supply voltage circuit.

Action Taken When the DTC Sets

- The EBCM disables the Traction Control System (TCS)/Vehicle Stability Enhancement System (VSES) for the duration of the ignition cycle.
- Driver information center (DIC) displays the TRACTION FAILED message.
- DIC displays the SERVICE STAB SYS message.
- Stability Caution indicator turns ON.

Conditions for Clearing the DTC

The DTC clears automatically from current status when the fault is corrected and the ignition is cycled. Use a scan tool to clear the DTC from history status.

Diagnostic Aids

B0010 sets if all of the reverse lamp bulbs are open.

Reference Information

Schematic Reference

- **Antilock Brake System Schematics**
- **Exterior Lights Schematics**

Connector End View Reference

- **Antilock Brake System Connector End Views**
- **Data Communication Connector End Views**

Electrical Information Reference

- **Circuit Testing**
- **Connector Repairs**
- **Testing for Intermittent Conditions and Poor Connections**
- **Wiring Repairs**

Scan Tool Reference

Scan Tool Data List

Circuit/System Testing

2007 Hummer H3

2007 BRAKES Antilock Brake System - H3

1. Turn ON the ignition with the engine OFF. Place the gear selector of the transmission in reverse. The reverse lamps should illuminate.
 - If the reverse lamps do not illuminate, go to **Diagnostic Aids** or **Symptoms - Lighting Systems** .
2. Turn the ignition OFF. Disconnect the EBCM harness connector. Connect a test lamp between the backup lamp supply voltage circuit of the harness connector and ground. Turn the ignition ON and place the gear selector of the transmission in reverse.
 - If the test lamp does not illuminate, repair open in the backup lamp supply voltage circuit between the splice and the EBCM connector.
 - If the test lamp illuminates, replace the EBCM/brake pressure modulator valve (BPMV) assembly.

Repair Procedures

Perform the **Diagnostic Repair Verification** after completing the diagnostic procedure.

- **Control Module References** for EBCM and BPMV replacement, setup and programming
- **Symptoms - Lighting Systems**

DTC B2745

DTC Descriptor

DTC B2745

Traction Control Switch Circuit

Diagnostic Fault Information

Perform the **Diagnostic System Check - Vehicle** prior to using this diagnostic procedure.

DTC B2745

Circuit	Short to Ground	Open/High Resistance	Short to Voltage	Signal Performance
TCS switch signal circuit	B2745	12	-	-
1. Traction control cannot be manually disabled.				

Circuit/System Description

The driver may disable the Traction Control System (TCS) by pressing the traction control

switch. The body control module (BCM) supplies a 12-volt signal on the traction control signal circuit. When the traction control switch is pressed, this voltage signal is grounded.

Conditions for Running the DTC

The ignition is ON.

Conditions for Setting the DTC

The BCM detects low voltage on the traction control signal circuit for 60 seconds.

Action Taken When the DTC Sets

- The BCM sends a serial data message to the electronic brake control module (EBCM) informing the EBCM that the desired TCS state cannot be determined.
- The EBCM defaults the TCS status to enabled.

Conditions for Clearing the DTC

The DTC clears automatically from Current status when the fault is corrected. Use a scan tool to clear the DTC from history status.

Diagnostic Aids

An intermittent short to ground on the traction control signal circuit is the most likely cause of a history DTC when no problem is found. When the Conditions for Setting this DTC are present, the driver is not able to disable traction control.

Reference Information

Schematic Reference

Antilock Brake System Schematics

Connector End View Reference

- **SIR Connector End Views**
- **Data Communication Connector End Views**

Electrical Information Reference

- **Circuit Testing**
- **Connector Repairs**

2007 Hummer H3

2007 BRAKES Antilock Brake System - H3

- **Testing for Intermittent Conditions and Poor Connections**
- **Wiring Repairs**

Scan Tool Reference

Scan Tool Data List

Circuit/System Verification

Traction control can be disabled/enabled when the traction control switch is pressed and released.

Circuit/System Testing

1. Turn OFF the ignition for 5 seconds, then turn ON the ignition and wait at least 60 seconds.
 - If DTC B2745 does not reset, go to **Diagnostic Aids**.
2. Turn the ignition OFF. Disconnect the traction control switch harness connector. Turn the ignition ON and wait at least 60 seconds.
 - If DTC B2745 does not reset, replace the traction control switch.
 - If the DTC B2745 resets, check the TCS switch signal circuit for a short to ground or replace the BCM.

Repair Procedures

Perform the **Diagnostic Repair Verification** after completing the diagnostic procedure.

- **Accessory Switch Replacement**
- **Control Module References** for BCM replacement, setup and programming.

DTC C0035-C0050

DTC Descriptor

DTC C0035

Left Front Wheel Speed Sensor Circuit

DTC C0040

Right Front Wheel Speed Sensor Circuit

DTC C0045

2007 Hummer H3

2007 BRAKES Antilock Brake System - H3

Left Rear Wheel Speed Sensor Circuit

DTC C0050

Right Rear Wheel Speed Sensor Circuit

Diagnostic Fault Information

IMPORTANT: Always perform the Diagnostic System Check - Vehicle prior to using this diagnostic procedure.

DTC C0035-C0050

Circuit	Short to Ground	Open or High Resistance	Short to Voltage	Signal Performance
Left Front Sensor Signal	C0035	C0035	C0035	C0035
Left Front Sensor Low Reference	C0035	C0035	C0035	C0035
Right Front Sensor Signal	C0040	C0040	C0040	C0040
Right Front Sensor Low Reference	C0040	C0040	C0040	C0040
Left Rear Sensor Signal	C0045	C0045	C0045	C0045
Left Rear Sensor Low Reference	C0045	C0045	C0045	C0045
Right Rear Sensor Signal	C0050	C0050	C0050	C0050
Right Rear Sensor Low Reference	C0050	C0050	C0050	C0050

Circuit/System Description

The wheel speed sensor receives a 12-volt power supply voltage from the electronic brake control module (EBCM) and provides an output signal to the EBCM. As the wheel spins, the wheel speed sensor sends the EBCM a DC square wave signal. The EBCM uses the frequency of the square wave signal to calculate the wheel speed.

Conditions for Running the DTC

C0035-C0050

- The ignition is ON.
- Ignition voltage is greater than 9 volts.

2007 Hummer H3

2007 BRAKES Antilock Brake System - H3

- Vehicle speed is greater than 10 km/h (6 mph) is required to detect rolling wheel speed failures.

Conditions for Setting the DTC

C0035-C0050

- An erratic signal output of the wheel speed sensor is detected.
- A short to voltage, open or ground is detected on the wheel speed sensor signal circuit.
- A open or short to ground in the wheel speed sensor circuit supply voltage.
- Wheel speed sensor power supply is less than 7.6 volts.
- A missing wheel speed sensor signal

Action Taken When the DTC Sets

- The EBCM disables the Antilock Brake System (ABS)/Traction Control System (TCS)/Vehicle Stability Enhancement System (VSES) for the duration of the ignition cycle.
- ABS indicator turns ON.
- Driver information center (DIC) displays the ABS FAULT message.
- Stability Caution indicator turns on.
- DIC displays the SERVICE STAB SYS message.
- DIC displays the TRACTION FAILED message.
- If both rear wheel speed DTCs are set, the dynamic rear proportioning (DRP) is disabled and the Brake Warning indicator turns ON.

Conditions for Clearing the MIL/DTC

- The condition for setting the DTC is no longer present and the DTC is cleared with a scan tool.
- The EBCM automatically clears the history DTC when a current DTC is not detected in 100 consecutive drive cycles.
- An ECE 13 response may occur. If an ECE 13 response is present the vehicle must be operated at a speed greater than 15 km/h (9 mph) to turn off the ABS warning lamp.

Diagnostic Aids

If 2 or more wheel speed sensors are inoperative diagnose each wheel speed sensor individually.

If the customer comments that the ABS indicator is ON only during moist environmental

conditions: rain, snow, vehicle wash, etc., inspect the wheel speed sensor wiring for signs of water intrusion. If the DTC is not current, clear all DTCs and simulate the effects of water intrusion by using the following procedure:

1. Spray the suspected area with a 5 percent saltwater solution. To create a 5 percent saltwater solution, add 2 teaspoons of salt to 8 fl. oz. of water (10 g of salt to 200 ml of water).
2. Test drive the vehicle over various road surfaces, bumps, turns, etc., above 40 km/h (25 mph) for at least 30 seconds.
3. If the DTC returns, replace the suspected wheel speed sensor or repair the wheel speed sensor wiring.
4. Rinse the area thoroughly when completed.

Reference Information

Schematic Reference

Antilock Brake System Schematics

Connector End View Reference

Antilock Brake System Connector End Views

Electrical Information Reference

- **Circuit Testing**
- **Testing for Intermittent Conditions and Poor Connections**
- **Wiring Repairs**
- **Connector Repairs**

Scan Tool Reference

Scan Tool Data List

Circuit/System Verification

With scan tool installed drive the vehicle in a straight line at a speed greater than 10 km/h (6 mph), all wheel speed sensors should read the same speed.

Circuit/System Testing

Note: It is recommend that Component Testing is performed before Circuit Testing when diagnosing wheel speed sensors.

2007 Hummer H3

2007 BRAKES Antilock Brake System - H3

Note: Performing Circuit Testing with EBCM connector disconnected and key on will cause U codes to set. Clear DTCs after performing the test.

1. With the ignition OFF, Disconnect the wheel speed sensor connector. Ignition ON, Measure for voltage above 7.5 V on the wheel speed sensor signal circuit.
 - If voltage is below 7.5 check for a short to ground, open or replace EBCM.
2. Ignition OFF, disconnect the EBCM connector. With the EBCM connector disconnected and the ignition ON, measure for 0 volts between the wheel speed sensor signal circuit or the wheel speed sensor low reference circuit and ground at the EBCM connector.
 - If over 0 volts, repair short to voltage in the wheel speed sensor signal circuit or the wheel speed sensor supply voltage circuit.
3. With the ignition OFF and the wheel speed sensor harness disconnected, Measure for infinite ohms of resistance between ground and the wheel speed sensor signal and the wheel speed sensor low reference circuit from the EBCM connector.
 - If less than infinite ohms, repair short to ground in the sensor signal or the low reference circuit.
4. Measure for infinite ohms of resistance between the wheel speed sensor signal circuit and the wheel speed low reference circuit at the EBCM connector.
 - If less than infinite ohms, repair short between the wheel speed sensor signal circuit and the wheel speed sensor low reference circuit.
 - If all circuits test normal replace the suspect wheel speed sensor.

Component Testing

1. ignition OFF, disconnect the wheel speed sensor connector. Measure for 12 volts on the wheel speed sensor signal circuit.
 - If the If voltage is below 7.5 check for a short to ground, open or replace EBCM.
2. At the wheel speed sensor, connect a 3 Amp fused jumper wire between wheel speed sensor low reference terminal and the low reference terminal of the wheel speed harness connector. Set-up a DMM to measure current flow (mA/A). Connect the positive terminal of the DMM to the wheel speed sensor signal terminal at the wheel speed sensor harness connector and the negative lead to the wheel speed sensor signal terminal of the wheel speed sensor. Spin the wheel very slowly. Measure for 4-8 mA on the low reading and 12-16 mA on the high reading.
 - If the low amperage output of the wheel speed sensor signal circuit is below 4 mA or above 8 mA replace the wheel speed sensor.
 - If the high amperage output of the wheel speed sensor signal circuit is below 12 mA or above 16 mA replace the wheel speed sensor.

Repair Procedures

IMPORTANT: Always perform the Diagnostic Repair Verification after completing the diagnostic procedure.

- **Front Wheel Hub, Bearing and Seal Replacement**
- **Control Module References** for EBCM and BPMV replacement, setup and programming

DTC C0110

DTC Descriptor

DTC C0110

Pump Motor Circuit

Diagnostic Fault Information

IMPORTANT: Always perform the Diagnostic System Check - Vehicle prior to using this diagnostic procedure.

Circuit/System Description

The ABS pump motor recharges the brake fluid accumulator during antilock braking and normal power brake assist. The ABS pump motor is part of the hydraulic brake booster assembly.

Conditions for Running the DTC

Ignition voltage is greater than 9.5 volts.

Conditions for Setting the DTC

- The ABS pump runs continuously for 178 seconds.
- The EBCM detects an open in the pump motor circuit when the pump motor is activated.

Action Taken When the DTC Sets

- EBCM disables the Antilock Brake System (ABS)/Traction Control System (TCS)/Vehicle Stability Enhancement System (VSES) for the duration of the ignition cycle.
- ABS indicator turns ON.
- Brake warning indicator turns ON.
- Driver information center (DIC) displays the SERVICE ABS/TRACTION System message.

- DIC displays the SERVICE STAB SYS message.
- An ECE 13 response may occur.
- ABS pump motor runs intermittently, 2 seconds on and 8 seconds off.

Conditions for Clearing the DTC

- The condition for setting the DTC is no longer present and the DTC is cleared with a scan tool.
- The EBCM automatically clears the history DTC when a current DTC is not detected in 100 consecutive drive cycles.

Reference Information

Schematic Reference

Antilock Brake System Schematics

Connector End View Reference

Antilock Brake System Connector End Views

Electrical Information Reference

- **Circuit Testing**
- **Connector Repairs**
- **Testing for Intermittent Conditions and Poor Connections**
- **Wiring Repairs**

Scan Tool Reference

Scan Tool Data List

Circuit/System Verification

With the scan tool, access the ABS special functions menu and perform the ABS Motor test. The pump motor should function and no DTCs should be set.

Circuit/System Testing

1. With the ignition OFF, disconnect the main EBCM harness connector (C2) and the small 4-way EBCM harness connector (C1). At both EBCM harness connectors, test for 12 volts on the battery positive voltage circuits.

2007 Hummer H3

2007 BRAKES Antilock Brake System - H3

- If the voltage is below 10 volts, repair open or short to ground on the battery positive voltage circuit.
- 2. Connect one end of a test lamp to battery positive voltage. At the EBCM connector, touch the other end of the test lamp to each of the three ground circuits. The test lamp should illuminate.
 - If the test lamp does not illuminate when touched to each ground circuit, repair open in the suspected ground circuit.
- 3. Remove the two small rubber caps that cover the ABS pump motor connections to the EBCM. Connect a test lamp between the two terminals located under the rubber plugs. Turn the ignition ON. Use the scan tool to command the ABS pump motor ON.
 - If the test lamp illuminates, replace the hydraulic brake booster.
- If the test lamp does not illuminate, replace the EBCM/BPMV assembly.

Repair Procedures

IMPORTANT: Always perform the Diagnostic Repair Verification after completing the diagnostic procedure.

- Control Module References for EBCM replacement, setup and programming
- Power Brake Booster Replacement

DTC C0131

DTC Descriptor

DTC C0131

Antilock Brake System (ABS) Pressure Circuit

Diagnostic Fault Information

IMPORTANT: Always perform the Diagnostic System Check - Vehicle prior to using this diagnostic procedure.

Circuit/System Description

The ABS pump motor and accumulator operates the ABS and base brake power assist systems. Pressurized brake fluid is stored in the accumulator and used for ABS and base brake power assist functions. An accumulator pressure sensor located internally in the electronic brake control

2007 Hummer H3

2007 BRAKES Antilock Brake System - H3

module (EBCM) monitors the accumulator pressure. If accumulator pressure becomes too low, the ABS pump motor is commanded ON.

Conditions for Running the DTC

The ignition is ON

Conditions for Setting the DTC

- The accumulator internal power supply is out of range.
- The accumulator pressure sensor value changes more than 15 MPa in 0.08 seconds.
- The accumulator pressure signal fails to change at least 0.12 MPa during the accumulator pressure test.
- The EBCM detects that the accumulator pressure signal is too low when the vehicle is driven.

Action Taken When the DTC Sets

- The EBCM disables the Antilock Brake System (ABS)/Traction Control System (TCS)/Vehicle Stability Enhancement System (VSES) for the duration of the ignition cycle.
- The ABS indicator turns ON.
- The driver information center (DIC) displays the ABS FAULT message.
- The Stability Caution indicator turns on.
- The DIC displays the SERVICE STAB SYS message.
- The DIC displays the TRACTION FAILED message.

Conditions for Clearing the DTC

- The condition for the DTC is no longer present and the DTC is cleared with a scan tool.
- The EBCM automatically clears the history DTC when a current DTC is not detected in 100 consecutive drive cycles.

Diagnostic Aids

The accumulator pressure sensor is located internally in the BPMV and is not serviceable.

Reference Information

Schematic Reference

Antilock Brake System Schematics

Connector End View Reference

Antilock Brake System Connector End Views

Electrical Information Reference

- **Circuit Testing**
- **Connector Repairs**
- **Testing for Intermittent Conditions and Poor Connections**
- **Wiring Repairs**

Scan Tool Reference

Scan Tool Data List

Circuit/System Testing

IMPORTANT: If present, diagnose DTC C0110 or C0201 before DTC C0131. An inoperative ABS motor or control can cause DTC C0131 to set.

1. Cycle the ignition from OFF to ON. Observe the accumulator pressure data parameter on the scan tool. Fully apply and release the brake pedal once, the accumulator pressure should hold steady above 16.7 MPa.
 - If the accumulator pressure data parameter does not hold steady above 16.7 MPa, replace the accumulator.
2. Wait 60 seconds without depressing the pedal. The pump motor should not turn on.
 - If the ABS pump motor turns ON and OFF several times, replace the EBCM/brake pressure modulator valve (BPMV) assembly.
3. Cycle the ignition from OFF to ON. Apply and release the brake pedal continuously. The accumulator pressure should not be below 14.9 for 100 seconds consecutively.
 - If the accumulator pressure stays below 14.9 MPa for 100 seconds, replace the EBCM/BPMV assembly.
4. Test drive the vehicle and observe the accumulator pressure data parameter while driving. The accumulator should not fluctuate rapidly.
 - If the accumulator pressure fluctuates rapidly replace the EBCM/BPMV assembly.

Repair Procedures

IMPORTANT: Always perform the Diagnostic Repair Verification after

completing the diagnostic procedure.

- **Control Module References** for EBCM and BPMV replacement, setup and programming
- **Hydraulic Brake Booster Accumulator Replacement**

DTC C0136

DTC Descriptor

DTC C0136

Base Brake System Pressure Circuit

Diagnostic Fault Information

IMPORTANT: Always perform the Diagnostic System Check - Vehicle prior to using this diagnostic procedure.

Circuit/System Description

The electronic brake control module (EBCM) monitors an internal input from the master cylinder pressure sensor to enhance Antilock Brake System (ABS) braking and vehicle stability if equipped.

Conditions for Running the DTC

The ignition is ON.

Conditions for Setting the DTC

- When vehicle speed is more than 7 km/h (4 mph), the master cylinder pressure does not change for 30 seconds with the brake applied.
- When vehicle speed is more than 10 km/h (6 mph), the master cylinder pressure signal is erratic.
- Master cylinder pressure signal is out of range.
- Master cylinder pressure is high for 5 seconds with the stop lamp switch signal OFF.

Action Taken When the DTC Sets

- The EBCM disables traction control system (TCS) and vehicle stability enhancement system (VSES) for the duration of the ignition cycle.

2007 Hummer H3

2007 BRAKES Antilock Brake System - H3

- The Stability Caution indicator turns on.
- The driver information center (DIC) displays the TRACTION FAILED message.
- DIC displays the SERVICE STAB SYS message.
- An ECE 13 response may occur.

Conditions for Clearing the DTC

- The condition for the DTC is no longer present and the DTC is cleared with a scan tool.
- The EBCM automatically clears the history DTC when a current DTC is not detected in 100 consecutive drive cycles.

Diagnostic Aids

The master cylinder pressure sensor is located internally in the BPMV and is not serviceable.

Reference Information

Schematic Reference

- **Antilock Brake System Schematics**
- **Exterior Lights Schematics**

Connector End View Reference

Antilock Brake System Connector End Views

Electrical Information Reference

- **Circuit Testing**
- **Connector Repairs**
- **Testing for Intermittent Conditions and Poor Connections**
- **Wiring Repairs**

Scan Tool Reference

Scan Tool Data List for EBCM

Circuit/System Testing

Note: Inspect for brake lamp related DTCs and symptoms before diagnosing DTC C0136.

Note: A binding brake pedal or misadjusted brake switch can cause DTC C0136 to set. Correct

any hydraulic brake symptoms before diagnosing this DTC. Refer to **Symptoms - Hydraulic Brakes** .

Disconnect the EBCM harness connector. Connect a test lamp between the stop lamp switch signal circuit and ground. Apply the brake.

- If the test lamp does not illuminate but the center high mounted stop lamp (CHMSL) does illuminate, repair open in the stop lamp switch signal circuit.
- If the test lamp and CHMSL does not illuminate, go to **Symptoms - Lighting Systems** .
- If the test lamp and CHMSL illuminates, replace the EBCM/brake pressure modulator valve (BPMV).

Repair Procedures

IMPORTANT: Always perform the Diagnostic Repair Verification after completing the diagnostic procedure.

- **Control Module References** for EBCM and BPMV replacement, setup and programming
- **Symptoms - Lighting Systems**

DTC C0161

Diagnostic Instructions

- Perform the **Diagnostic System Check - Vehicle** prior to using this diagnostic procedure.
- Review **Strategy Based Diagnosis** for an overview of the diagnostic approach.
- **Diagnostic Procedure Instructions** provides an overview of each diagnostic category.

DTC Descriptor

DTC C0161

ABS Brake Switch Circuit

Circuit/System Description

The brake switch supplies battery positive voltage to the electronic brake control module (EBCM) when the brake pedal is applied.

Conditions for Running the DTC

Ignition voltage is greater than 9.5 volts.

Conditions for Setting the DTC

Stop switch is on and vehicle speed is greater than 15 km/h (9 mph) for 15 minutes continuously.

Action Taken When the DTC Sets

- EBCM disables traction control system (TCS) and vehicle stability enhancement system (VSES) for the duration of the ignition cycle.
- Stability Caution indicator turns ON.
- Driver information center (DIC) displays the TRACTION FAILED message.
- An ECE 13 response occurs.

Conditions for Clearing the DTC

- The condition for setting the DTC is no longer present and the DTC is cleared with a scan tool.
- The EBCM automatically clears the history DTC when a current DTC is not detected in 100 consecutive drive cycles.

Reference Information

Schematic Reference

Antilock Brake System Schematics

Connector End View Reference

Antilock Brake System Connector End Views

Electrical Information Reference

- **Circuit Testing**
- **Connector Repairs**
- **Testing for Intermittent Conditions and Poor Connections**
- **Wiring Repairs**

Scan Tool Reference

Scan Tool Data List

2007 Hummer H3

2007 BRAKES Antilock Brake System - H3

Circuit/System Verification

With the scan tool, observe the Brake Switch Status data parameter. Apply and release the brake pedal. The brake pedal switch status should change from OFF to ON.

Circuit/System Testing

1. Release the brake pedal. With the scan tool observe the Brake Switch Status data parameter.
 - If the fault is current, the scan tool brake switch status displays ON.
 - If the scan tool displays OFF, go to **Testing for Intermittent Conditions and Poor Connections** .
2. With the ignition OFF, disconnect the EBCM connector. With the Ignition ON release the brake pedal and connect a test lamp between the stop lamp switch signal circuit and ground.
 - If the test lamp illuminates go to **Symptoms - Lighting Systems** .
 - If the test lamp does not illuminate, replace the EBCM/brake pressure modulator valve (BPMV) assembly.

Repair Procedures

Perform the **Diagnostic Repair Verification** after completing the diagnostic procedure.

- **Symptoms - Lighting Systems**
- **Control Module References** for EBCM or BPMV replacement, setup and programming

DTC C0179

DTC Descriptor

DTC C0179

System Thermal High

Diagnostic Fault Information

IMPORTANT: Always perform the Diagnostic System Check - Vehicle prior to using this diagnostic procedure.

Circuit/System Description

The electronic brake control module (EBCM) monitors Traction Control System (TCS)

activation in order to calculate an estimate of the EBCM solenoid valve temperatures. In most cases high solenoid valve temperatures are caused by extended TCS activation. If the EBCM calculates that the solenoid valve temperatures are too high, the EBCM will temporarily suspend the TCS function until the solenoid valves cool.

Conditions for Running the DTC

The ignition is ON.

Conditions for Setting the DTC

The estimated solenoid coil temperature reaches the temperature limit.

Action Taken When the DTC Sets

- The EBCM disables the Antilock Brake System (ABS)/TCS/Vehicle Stability Enhancement System (VSES) for the duration of the ignition cycle.
- The ABS indicator turns ON.
- The driver information center (DIC) displays the ABS system message.
- The DIC displays the TRACTION FAILED system message.

Conditions for Clearing the DTC

- After the solenoid valves have cooled the EBCM automatically re-enables TCS function.
- The EBCM automatically clears the history DTC when a current DTC is not detected in 100 consecutive drive cycles.

Reference Information**Schematic Reference****Antilock Brake System Schematics****Connector End View Reference****Antilock Brake System Connector End Views****Electrical Information Reference**

- **Circuit Testing**
- **Connector Repairs**
- **Testing for Intermittent Conditions and Poor Connections**

- **Wiring Repairs**

Scan Tool Reference

Scan Tool Data List

Circuit/System Verification

With the scan tool, observe the Brake Switch Status data parameter. Apply and release the brake pedal. The brake pedal switch status should change from OFF to ON.

Circuit/System Testing

1. Most occurrences of this DTC are caused by excessive TCS activation or braking. Review with the customer to verify the conditions under which the DTC set.
 - If vehicle operation caused this DTC to set, clear the DTC.
2. Test drive the vehicle under normal conditions
 - If the DTC resets under normal driving conditions, replace the EBCM/brake pressure modulator valve (BPMV).

Repair Procedures

IMPORTANT: Always perform the Diagnostic Repair Verification after completing the diagnostic procedure.

Control Module References for EBCM and BPMV replacement, setup and programming

DTC C0186 OR C0196

Diagnostic Instructions

- Perform the **Diagnostic System Check - Vehicle** prior to using this diagnostic procedure.
- Review **Strategy Based Diagnosis** for an overview of the diagnostic approach.
- **Diagnostic Procedure Instructions** provides an overview of each diagnostic category.

DTC Descriptor

DTC C0186

Lateral Accelerometer Circuit

DTC C0196

Yaw Rate Circuit

Circuit/System Description

The yaw rate, lateral and longitudinal accelerometers are combined into one combination sensor external to the electronic brake control module (EBCM). The combination sensor receives ignition power and a ground that is separate from the EBCM. The combination sensor sends dedicated serial data messages to the EBCM regarding vehicle yaw rate, lateral and longitudinal acceleration.

Conditions for Running the DTC

The ignition is ON.

Conditions for Setting the DTC

C0186

- Lateral acceleration does not change when reducing speed from 30 km/h to 0 km/h and the condition occurs 16 times in a row
- Yaw rate, lateral and longitudinal acceleration do not correlate with the vehicle stationary
- Yaw rate, lateral and longitudinal acceleration do not correlate based on estimated wheel speed.
- Combination sensor fails an internal self test.
- Ignition voltage to the yaw/lateral combination sensor is less than 9.5 volts.
- Communication is lost between the EBCM and the combination sensor.

C0196

- Vehicle speed has reached at least 15 km/h (9 mph) from a stop more three times during the same ignition cycle. During the time the vehicle is stationary; the yaw rate signal value is more than 7 deg/sec for 2 seconds.
- When vehicle speed is more than 25 km/h (16 mph) in a turn the difference between the yaw rate, steering angle, lateral acceleration and wheel speed sensor values are not correlated three consecutive times.
- Yaw rate changes greater than 20 deg/sec in 6 ms four times in one second.
- Combination sensor fails an internal self test.
- Ignition voltage to the combination sensor is less than 9.5 volts.
- Communication is lost between the EBCM and the combination sensor.

Action Taken When the DTC Sets

C0186

- The EBCM disables the Antilock Brake System (ABS)/Traction Control System (TCS)/Vehicle Stability Enhancement System (VSES) for the duration of the ignition cycle.
- The ABS indicator turns ON.
- The driver information center (DIC) displays the ABS FAULT message.
- The Stability Caution indicator turns on.
- The DIC displays the SERVICE STAB SYS message.
- The DIC displays the TRACTION FAILED message.

C0196

- The EBCM disables the VSES for the duration of the ignition cycle.
- The DIC displays the SERVICE STAB SYS message.
- The Stability Caution indicator turns on.

Conditions for Clearing the DTC

- The condition for the DTC is no longer present and the DTC is cleared with a scan tool.
- The EBCM automatically clears the history DTC when a current DTC is not detected in 100 consecutive drive cycles.

Reference Information

Schematic Reference

Antilock Brake System Schematics

Connector End View Reference

Antilock Brake System Connector End Views

Description and Operation

ABS Description and Operation

Electrical Information Reference

- **Circuit Testing**

- **Connector Repairs**
- **Testing for Intermittent Conditions and Poor Connections**
- **Wiring Repairs**

Scan Tool Reference

- **Scan Tool Data List**
- **Scan Tool Data Definitions**

Circuit/System Testing

1. Ignition OFF, disconnect the harness connector at the yaw rate/lateral and longitudinal accelerometer sensor.
2. Test for less than 1 ohm of resistance between the ground terminal 4 and ground.
 - If greater than the specified range, test for an open/high resistance in the ground circuit.
3. Ignition ON, verify that a test lamp illuminates between the ignition circuit terminal 1 and ground.
 - If the test lamp does not illuminate, test the ignition circuit for a short to ground or an open/high resistance.
4. Ignition OFF, disconnect the C2 harness connector at the EBCM.
5. Ignition ON, test for 0 volts between the CAN HI circuit terminal 11 and ground.
 - If greater than the specified value, test the CAN HI circuit for a short to voltage.
6. Test for 0 volts between the CAN LO circuit terminal 25 and ground.
 - If greater than the specified value, test the CAN LO circuit for a short to voltage.
7. Ignition OFF, test for infinite resistance between the CAN HI circuit terminal 11 and ground.
 - If not the specified value, test the suspect circuit for a short to ground.
8. Test for infinite resistance between the CAN LO circuit terminal 25 and ground.
 - If not the specified value, test the CAN LO circuit for a short to ground.
9. Test for less than 1 ohm of resistance between the CAN HI circuit terminal 11 and terminal 2.
 - If greater than the specified range, test the CAN HI circuit for an open/high resistance.
10. Test for less than 1 ohm of resistance between the CAN LO circuit terminal 3 and terminal 25.
 - If greater than the specified range, test the CAN LO circuit for an open/high resistance.

2007 Hummer H3

2007 BRAKES Antilock Brake System - H3

11. Test for infinite resistance between the CAN HI terminal 11 and the CAN LO terminal 25.
 - If not the specified value, test the CAN HI and CAN LO circuits for a short together.
12. If all circuits test normal, replace the Yaw Rate/Lateral sensor.

Repair Procedures

Perform the **Diagnostic Repair Verification** after completing the diagnostic procedure.

Vehicle Yaw Sensor with Vehicle Lateral and Longitudinal Accelerometer Replacement

DTC C0191

DTC Descriptor

DTC C0191

Four Wheel Drive (4WD) Reference Accelerometer Circuit

Diagnostic Fault Information

IMPORTANT: Always perform the Diagnostic System Check - Vehicle prior to using this diagnostic procedure.

Circuit/System Description

The electronic brake control module (EBCM) supplies a 5-volt reference to the longitudinal accelerometer. When the vehicle is not moving or is being driven at a constant steady speed, longitudinal acceleration is 0 m/sec/sec and the longitudinal accelerometer signal voltage is very near 2.5 volts. This is referred to as longitudinal accelerometer bias voltage. Vehicle acceleration or deceleration causes the longitudinal accelerometer signal voltage to increase or decrease.

Conditions for Running the DTC

- The ignition is ON.
- Ignition voltage is greater than 8 volts.

Conditions for Setting the DTC

- The 5-volt reference to the longitudinal accelerometer is less than 4.4 volts or greater than 5.6 volts.
- The longitudinal accelerometer output is greater than 1.5 g or less than -1.5 g for 1.2 seconds.

2007 Hummer H3

2007 BRAKES Antilock Brake System - H3

- The longitudinal accelerometer output is greater than 1.5 g or less than -1.5 g for 7 200 ms periods during the same ignition cycle.
- The longitudinal accelerometer output does not change when the vehicle decelerates from 30 km/h (19 mph) to 0 km/h. If the condition occurs 16 consecutive times, the DTC is set.

Action Taken When the DTC Sets

- The EBCM disables the Antilock Brake System (ABS)/Traction Control System (TCS) for the duration of the ignition cycle.
- The ABS indicator turns ON.
- The driver information center (DIC) displays the ABS FAULT message.
- The DIC displays the TRACTION FAILED message.

Conditions for Clearing the DTC

- The condition for setting the DTC is no longer present and the DTC is cleared with a scan tool.
- The EBCM automatically clears the history DTC when a current DTC is not detected in 100 consecutive drive cycles.

Reference Information

Schematic Reference

Antilock Brake System Schematics

Connector End View Reference

Antilock Brake System Connector End Views

Electrical Information Reference

- Circuit Testing
- Connector Repairs
- Testing for Intermittent Conditions and Poor Connections
- Wiring Repairs

Scan Tool Reference

Scan Tool Data List

Circuit/System Verification

With scan tool installed drive the vehicle in a straight line at a speed greater than 30 km/h (19 mph) and decelerate the vehicle to a stop several times. The scan tool Longitudinal Accelerometer Sensor Signal parameter should show a change in M/S^2 output in sequence to the vehicle deceleration.

Circuit/System Testing

1. Turn OFF the ignition. Disconnect the longitudinal accelerometer harness connector. Turn ON the ignition. With a DMM, verify voltage between 4.4 and 5.6 on the LNG rate sensor 5-volt reference circuit.
 - If the voltage is above 5.6 volts, test for a short to power on the LNG rate sensor circuit. If the circuit tests normal, replace the EBCM.
 - If voltage is below 4.4, test for an open or a short to ground on the LNG rate sensor circuit. If the circuit tests normal, replace the EBCM assembly.
2. Turn OFF the ignition. At the longitudinal accelerometer harness connector, connect a test lamp between the LNG low reference circuit and battery positive voltage. Verify the test lamp illuminates.
 - If the test lamp does not illuminate check for an open in the LGN low reference circuit. If the circuit tests normal, replace the EBCM assembly.
3. Connect a 3-amp fused jumper wire between the LNG rate sensor 5-volt reference circuit and the longitudinal accelerometer signal circuit. Turn ON the ignition and observe the longitudinal accelerometer parameter.
 - If the scan tool displays greater than 1.5g, replace the longitudinal position sensor.
 - If the scan tool displays less than 1.5g, test for an open or short to ground on the longitudinal accelerometer signal circuit. If the circuit tests normal, replace the EBCM assembly.

Repair Procedures

IMPORTANT: Always perform the Diagnostic Repair Verification after completing the diagnostic procedure.

- **Vehicle Yaw Sensor with Vehicle Lateral and Longitudinal Accelerometer Replacement**
- **Control Module References** for EBCM and BPMV replacement, setup and programming

DTC Descriptor**DTC C0201**

Antilock Brake System (ABS) Enable Relay Contact Circuit

Diagnostic Fault Information

IMPORTANT: Always perform the Diagnostic System Check - Vehicle prior to using this diagnostic procedure.

Circuit/System Description

The solenoid and pump motor relay are located within the electronic brake control module (EBCM). The solenoid relay supplies battery voltage to all of the valve solenoids. Three pump motor relays supply battery positive voltage to the pump motor when the EBCM commands the pump motor on.

Conditions for Running the DTC

- Ignition voltage is greater than 9.5 volts.
- The solenoid relay is commanded ON.

Conditions for Setting the DTC

One or more of the following conditions exists:

- The EBCM detects an open in the battery positive voltage circuit to the solenoid valve relay.
- The EBCM detects a stuck open solenoid valve relay or an open circuit between the solenoid valve relay and solenoid valves.
- The EBCM detects an open in the battery positive voltage circuit to the solenoid valve relay.
- The EBCM detects that one or more of the pump motor relays is off when commanded on.

Action Taken When the DTC Sets

- The EBCM disables the Antilock Brake System (ABS)/Traction Control System (TCS)/Vehicle Stability Enhancement System (VSES) for the duration of the ignition cycle.
- The ABS indicator turns ON.
- The driver information center (DIC) displays the ABS FAULT message.

2007 Hummer H3

2007 BRAKES Antilock Brake System - H3

- The Stability Caution indicator turns ON.
- The DIC displays the SERVICE STAB SYS message.
- The DIC displays the TRACTION FAILED message.
- The Brake Warning indicator turns ON.

Conditions for Clearing the DTC

- The condition for setting the DTC is no longer present and the DTC is cleared with a scan tool.
- The EBCM automatically clears the history DTC when a current DTC is not detected in 100 consecutive drive cycles.

Reference Information

Schematic Reference

Antilock Brake System Schematics

Connector End View Reference

Antilock Brake System Connector End Views

Electrical Information Reference

- Circuit Testing
- Connector Repairs
- Testing for Intermittent Conditions and Poor Connections
- Wiring Repairs

Scan Tool Reference

Scan Tool Data List

Circuit/System Verification

With the scan tool, access the ABS special functions menu and perform the Solenoid Test and ABS Motor test. The pump motor and solenoids should function without setting DTCs.

Circuit/System Testing

Disconnect the EBCM harness connector. Connect a test lamp to ground, at the EBCM harness connector touch the test lamp probe to each of the 3 battery positive voltage circuits. The test

lamp should illuminate on all 3 circuits.

- If the test lamp does not illuminate on one of the battery positive voltage circuits, repair open or short to ground on the suspected circuit.

Connect a test lamp to battery positive voltage, at the EBCM harness connector touch the test lamp probe to each of the 3 ground circuits. The test lamp should illuminate on all 3 circuits.

- If the test lamp does not illuminate on one of the ground circuits, repair open or short to voltage on the suspected circuit.
- If no wiring faults can be found, replace the EBCM/brake pressure modulator valve (BPMV) assembly.

Repair Procedures

IMPORTANT: Always perform the Diagnostic Repair Verification after completing the diagnostic procedure.

Control Module References for EBCM and BPMV replacement, setup and programming

DTC C0240 OR P0856

Diagnostic Instructions

- Perform the **Diagnostic System Check - Vehicle** prior to using this diagnostic procedure.
- Review **Strategy Based Diagnosis** for an overview of the diagnostic approach.
- **Diagnostic Procedure Instructions** provides an overview of each diagnostic category.

DTC Descriptors

DTC C0240

PCM Traction Control Not Allowed

DTC P0856

Traction Control Torque Request Circuit

Circuit/System Description

C0240

2007 Hummer H3

2007 BRAKES Antilock Brake System - H3

The powertrain control module (PCM) and the electronic brake control module (EBCM) communicate on the serial data link, whenever the ignition is ON.

P0856

The PCM supplies 5 volts through an internal resistor, to the EBCM on the requested torque signal circuit. The EBCM toggles this voltage to ground to create a valid requested torque signal at the PCM.

Conditions for Running the DTC

C0240

The ignition is ON.

P0856

- The ignition is ON.
- The engine is running at a speed greater than 450 RPM for 5-20 seconds.

Conditions for Setting the DTC

C0240

The EBCM receives a serial data message stating that the PCM has lost the ability to reduce engine torque.

P0856

The PCM receives an invalid requested torque signal for 3 seconds.

Action Taken When the DTC Sets

C0240

- The EBCM disables the traction control system (TCS) and vehicle stability enhancement system (VSES).
- The TRACTION FAILED message is displayed.
- The Stability Caution indicator turns ON.
- The DIC displays the SERVICE STAB SYS message.

P0856

2007 Hummer H3

2007 BRAKES Antilock Brake System - H3

- The PCM sends a serial data message to the EBCM stating that the PCM has lost the ability to reduce engine torque.
- The EBCM sets DTC C0240 as a current DTC for as long as the malfunction is present.

Conditions for Clearing the DTC

C0240

The conditions for setting the DTC are no longer present and you use the scan tool Clear DTCs function.

P0856

- The conditions for setting the DTC are no longer present and you use the scan tool Clear DTCs function.
- A history DTC clears automatically after 40 consecutive warm-up cycles without a PCM detected failure.

Diagnostic Aids

C0240

A requested torque signal malfunction is only one possible cause for the PCM to lose the ability to perform traction control. DTC C0240 may set due to engine overheating, throttle actuator control failure, loss of ignition timing control by the PCM, etc. If DTC P1571 has not set, refer to **Diagnostic System Check - Vehicle** to identify other possible causes of DTC C0240.

P0856

Thoroughly inspect connections or circuitry that may cause an intermittent malfunction.

Reference Information

Schematic Reference

Antilock Brake System Schematics

Connector End View Reference

- **Antilock Brake System Connector End Views**
- **Powertrain Control Module Connector End Views**

Electrical Information Reference

- **Circuit Testing**
- **Connector Repairs**
- **Testing for Intermittent Conditions and Poor Connections**
- **Wiring Repairs**

Scan Tool Reference

Scan Tool Data List

Circuit/System Testing

1. Use a scan tool in order to clear the DTCs. Cycle the ignition to OFF and then start the engine. A current failure will set a DTC.
 - If the DTC does not reset, go to **Diagnostic Aids**.
2. Turn OFF the ignition and disconnect the EBCM harness connector. At the EBCM harness connector, use a DMM to measure for 5 volts on the requested torque circuit. Turn ON the ignition.
 - If the voltage is below 4.5 volts, test for an open or short to ground on the requested torque circuit or replace the PCM.
 - If the voltage is above 6 volts, test for a short to power or replace the PCM.
3. Connect one end of a test lamp to ground. With the DMM still connected to the EBCM harness connector, touch the other end of the test lamp to the DMM lead connected to the EBCM harness connector. The DMM voltage reading should drop below 0.5 volt.
 - If the voltage does not drop to below 0.5 volt, check for a short to voltage on the requested torque circuit or replace the PCM.

Repair Procedures

Perform the **Diagnostic Repair Verification** after completing the diagnostic procedure.

Control Module References for EBCM or PCM replacement, setup and programming

DTC C0244 OR P1689

DTC Descriptor

DTC C0244

Pulse Width Modulated (PWM) Delivered Torque

DTC P1689**Traction Control Delivered Torque Output Circuit****Diagnostic Fault Information**

Perform the **Diagnostic System Check - Vehicle** prior to using this diagnostic procedure.

Circuit/System Description

The electronic brake control module (EBCM) and the powertrain control module (PCM) simultaneously control the Traction Control System (TCS). The PCM sends a Delivered Torque message via a pulse width modulated (PWM) signal to the EBCM. The duty cycle of the signal is used to determine how much engine torque the PCM is delivering.

Conditions for Running the DTC

The ignition is ON and the engine is running.

Conditions for Setting the DTC

- Pulse signals from the Delivered Torque signal are not detected or are abnormal.
- The Duty Cycle is less than 5 percent or more than 95 percent.

Action Taken When the DTC Sets

- The EBCM disables TCS and vehicle stability enhancement system (VSES) for the duration of the ignition cycle.
- The Stability Caution indicator turns on.
- The driver information center (DIC) displays the TRACTION FAILED message.
- The DIC displays the SERVICE STAB SYS message.

Conditions for Clearing the DTC

- The condition for the DTC is no longer present and the DTC is cleared with a scan tool.
- The EBCM automatically clears the history DTC when a current DTC is not detected in 100 consecutive drive cycles.

Diagnostic Aids

Thoroughly inspect connections or circuitry that may cause an intermittent malfunction.

Reference Information

Schematic Reference

Antilock Brake System Schematics

Connector End View Reference

- **Antilock Brake System Connector End Views**
- **Powertrain Control Module Connector End Views**

Electrical Information Reference

- **Circuit Testing**
- **Connector Repairs**
- **Testing for Intermittent Conditions and Poor Connections**
- **Wiring Repairs**

Scan Tool Reference

Scan Tool Data List

Circuit/System Testing

1. Use a scan tool in order to clear the DTCs. Cycle the ignition to OFF and then start the engine. A current failure will set a DTC.
 - If the DTC does not reset, go to **Diagnostic Aids**.
2. Turn OFF the ignition and disconnect the PCM harness connector. At the PCM harness connector, use a DMM to measure for 12 volts on the delivered torque circuit. Turn ON the ignition.
 - If the voltage is below 10 volts, test for an open or short to ground on the requested torque circuit or replace the EBCM/brake pressure modulator valve (BPMV) assembly.
3. Connect one end of a test lamp to ground. With the DMM still connected to the PCM harness connector, touch the other end of the test lamp to the DMM lead connected to the PCM harness connector. The DMM voltage reading should drop below 0.5 volts.
 - If the voltage does not drop to below 0.5 volts, check for a short to voltage on the requested torque circuit. If a short to voltage cannot be found, replace the EBCM/brake pressure modulator valve (BPMV) assembly.

Repair Procedures

Perform the **Diagnostic Repair Verification** after completing the diagnostic procedure.

Control Module References for EBCM/BPMV or PCM replacement, setup and programming**DTC C0245****DTC Descriptor****DTC C0245**

Wheel Speed Sensor Frequency Error

Diagnostic Fault Information

IMPORTANT: Always perform the Diagnostic System Check - Vehicle prior to using this diagnostic procedure.

Circuit/System Description

The wheel speed sensor receives a 12-volt reference voltage from the electronic brake control module (EBCM). As the wheel spins, the wheel speed sensor sends the EBCM a DC square wave signal via the wheel speed sensor output circuit. The EBCM uses the frequency of the square wave signal to calculate the wheel speed.

Conditions for Running the DTC

- Ignition voltage is greater than 8 volts.
- Vehicle must be moving at a speed greater than 30 km/h.

Conditions for Setting the DTC

- The difference between 2 wheel speeds exceeds 20 percent.
- The fault must be present for greater than 60 seconds.

Action Taken When the DTC Sets

- The EBCM disables the Antilock Brake System (ABS)/Traction Control System (TCS)/Vehicle Stability Enhancement System (VSES) for the duration of the ignition cycle.
- The ABS indicator turns ON.
- The driver information center (DIC) displays the ABS FAULT message.
- The Stability Caution indicator turns on.
- The DIC displays the SERVICE STAB SYS message.
- The DIC displays the TRACTION FAILED message.

Conditions for Clearing the DTC

- The condition for the DTC is no longer present and the DTC is cleared with a scan tool.
- The EBCM automatically clears the history DTC when a current DTC is not detected in 100 consecutive drive cycles.

Diagnostic Aids

Inspect tires for improper air pressure or improper size.

DTC C0268

Diagnostic Instructions

- Perform the **Diagnostic System Check - Vehicle** prior to using this diagnostic procedure.
- Review **Strategy Based Diagnosis** for an overview of the diagnostic approach.
- **Diagnostic Procedure Instructions** provides an overview of each diagnostic category.

DTC Descriptor

DTC C0268

Class 2 Data Error Reported

Circuit/System Description

The electronic brake control module (EBCM) disables the traction control when other electronic control modules set DTCs for components that affect the operation of the traction control system.

Conditions for Running the DTC

The ignition switch is in the ON position.

Conditions for Setting the DTC

The PCM or BCM diagnoses a condition preventing the engine control portion of the traction control function and sends a serial data message to the EBCM indicating that torque reduction is not allowed. The PCM or BCM will typically set a DTC and the EBCM will set this DTC.

Action Taken When the DTC Sets

One or more of the following actions may occur:

2007 Hummer H3

2007 BRAKES Antilock Brake System - H3

- The EBCM disables the Antilock Brake System (ABS)/Traction Control System (TCS)/Vehicle Stability Enhancement System (VSES) for the duration of the ignition cycle.
- DRP may be disabled and the Brake Warning indicator may turn ON.
- Stability Caution indicator turns ON.
- DIC displays the SERVICE STAB SYS message.
- DIC displays the TRACTION FAILED message.

Conditions for Clearing the MIL/DTC

- The condition for the DTC is no longer present and the DTC is cleared with a scan tool.
- The EBCM automatically clears the history DTC when a current DTC is not detected in 100 consecutive drive cycles.

Circuit/System Verification

This DTC is for information only. As an aid to the technician, this DTC indicates that there are no problems in the ABS/TCS system.

Repair Procedures

Perform the Diagnostic Repair Verification after completing the diagnostic procedure.

Control Module References for EBCM replacement, setup and programming

DTC C0276

DTC Descriptor

DTC C0276

Transmission Control Module (TCM) Traction Control Not Allowed

Diagnostic Fault Information

Perform the **Diagnostic System Check - Vehicle** prior to using this diagnostic procedure.

Circuit/System Description

The electronic brake control module (EBCM) may inhibit the Traction Control System (TCS) if a failure occurs with the locking differential or the transfer case.

Conditions for Running the DTC

2007 Hummer H3

2007 BRAKES Antilock Brake System - H3

The ignition is ON.

Conditions for Setting the DTC

- The transfer case selected range has been reported as invalid by the transfer case control module (TCCM).
- The rear differential status has been reported as locked by the TCCM when the vehicle speed is greater than 50 km/h (31 mph) for 10 seconds.

Action Taken When the DTC Sets

- The EBCM disables the TCS and Vehicle Stability Enhancement System (VSES) for the duration of the ignition cycle.
- The driver information center (DIC) displays the SERVICE TRACTION message.
- The DIC displays the SERVICE STAB SYS message.

Conditions for Clearing the DTC

- The condition for the DTC is no longer present.
- Using a scan tool, clear the DTC function.

Diagnostic Aids

Check the TCCM for DTCs.

DTC C0550

DTC Descriptor

DTC C0550

Electronic Control Unit (ECU) Performance

Diagnostic Fault Information

IMPORTANT: Always perform the Diagnostic System Check - Vehicle prior to using this diagnostic procedure.

Circuit/System Description

The electronic brake control module (EBCM) detects an internal malfunction.

Conditions for Running the DTC

2007 Hummer H3

2007 BRAKES Antilock Brake System - H3

The ignition switch is in the ON position.

Conditions for Setting the DTC

An internal EBCM malfunction exists.

Action Taken When the DTC Sets

One or more of the following actions may occur:

- The EBCM disables the Antilock Brake System (ABS)/Traction Control System (TCS)/Vehicle Stability Enhancement System (VSES) for the duration of the ignition cycle.
- The dynamic rear proportioning (DRP) may be disabled and the Brake Warning indicator may turn ON.
- The Stability Caution indicator turns ON.
- The DIC displays the SERVICE STAB SYS message.
- The DIC displays the TRACTION FAILED message.

Conditions for Clearing the MIL/DTC

- The condition for the DTC is no longer present and the DTC is cleared with a scan tool.
- The EBCM automatically clears the history DTC when a current DTC is not detected in 100 consecutive drive cycles.

Circuit/System Verification

DTC C0550 will set as result of internal EBCM circuit failure.

- Replace the EBCM.

Repair Procedures

IMPORTANT: Always perform the Diagnostic Repair Verification after completing the diagnostic procedure.

Control Module References - for EBCM replacement, setup and programming

DTC C0710

Diagnostic Instructions

- Perform the **Diagnostic System Check - Vehicle** prior to using this diagnostic procedure.

- Review **Strategy Based Diagnosis** for an overview of the diagnostic approach.
- **Diagnostic Procedure Instructions** provides an overview of each diagnostic category.

DTC Descriptor**DTC C0710**

Steering Position Signal

Circuit/System Description

The electronic brake control module (EBCM) receives a digital and an analog steering wheel position signal from one sensor. The EBCM uses the steering wheel position sensor (SWPS) signals to perform Vehicle Stability Enhancement System (VSES). The analog and digital data parameters on the scan tool normally range from +220° to -220°. With the steering and steering wheel centered, the analog data parameter on the scan tool should display near 0°. The digital data parameter will calibrate to 0° after each key cycle regardless of actual steering wheel position. The EBCM verifies the accuracy of the steering wheel position signal by correlating the digital and analog signals together.

Conditions for Running the DTC

The ignition is ON.

Conditions for Setting the DTC

- Vehicle speed is greater than 15 km/h (9 mph), the steering angle does not change more than 10 degrees in 20 seconds and the yaw rate is 8.6 degrees/sec or more.
- The digital and analog steering wheel position signals do not correlate.

Action Taken When the DTC Sets

- The EBCM disables the VSES for the duration of the ignition cycle.
- Stability Caution indicator turns ON.
- The driver information center (DIC) displays the SERVICE STAB SYS message.

Conditions for Clearing the DTC

- The condition for the DTC is no longer present and the DTC is cleared with a scan tool.
- The EBCM automatically clears the history DTC when a current DTC is not detected in 100 consecutive drive cycles.

Reference Information

Schematic Reference

Antilock Brake System Schematics

Connector End View Reference

Antilock Brake System Connector End Views

Description and Operation

ABS Description and Operation

Electrical Information Reference

- Circuit Testing
- Connector Repairs
- Testing for Intermittent Conditions and Poor Connections
- Wiring Repairs

Scan Tool Reference

Scan Tool Data List

Circuit/System Verification

Test drive the vehicle at a speed greater than 15 km/h (9 mph) and make several turns. The DTC should not reset.

Circuit/System Testing

1. Ignition OFF, disconnect the harness connector at the SWPS.
2. Ignition OFF, test for less than 1 ohm of resistance between the ground circuit terminal 8 and ground.
 - If greater than the specified range, test the ground circuit for an open/high resistance.
3. Test for less than 1 ohm of resistance between the low reference circuit terminal 2 and ground.
 - If greater than the specified range, test the low reference circuit for an open/high resistance. If the circuit tests normal, replace the EBCM.

2007 Hummer H3

2007 BRAKES Antilock Brake System - H3

4. Ignition ON, verify that a test lamp illuminates between the ignition circuit terminal 7 and ground.
 - If the test lamp does not illuminate, test the ignition circuit for a short to ground or an open/high resistance. If the circuit tests normal and the fuse is OK, replace the HVAC relay 87.
5. Test for 4.8-5.2 volts between the 5-volt reference circuit terminal 1 and ground.
 - If less than the specified range, test the 5-volt reference circuit for a short to ground or an open/high resistance. If the circuit tests normal, replace the EBCM.
 - If greater than the specified range, test the 5-volt reference circuit for a short to voltage. If the circuit tests normal, replace the EBCM.
6. Test for 4.8-5.2 volts between the 5-volt reference circuit terminal 1 and the signal terminal 6.
 - If less than the specified range, test the signal circuit for an open/high resistance. If the circuit tests normal, replace the EBCM.
 - If greater than the specified range, test the signal circuit for a short to voltage. If the circuit tests normal, replace the EBCM.
7. Reconnect the SWPS.
8. Disconnect the EBCM C2 harness connector.
9. Ignition OFF, test for infinite resistance between the signal circuit pin 39 and ground.
 - If less than the specified range, test the signal circuit for a short to ground.
10. Ignition ON, test for an ignition voltage pulse between ground and the signal A circuit terminal 23 and signal B circuit terminal 22 while turning the steering wheel.
 - If not the specified value, test the signal circuits for a short to voltage, short to ground or an open/high resistance. If the circuit tests normal, replace the SWPS.
11. Position the wheels straight and the steering wheel within 10 degrees of center.
12. Test for ignition voltage between the marker pulse signal circuit terminal 8 and ground.
 - If less than the specified range, test the signal circuit for a short to ground or an open/high resistance. If the circuit tests normal, replace the SWPS.
13. Center the front wheels and steering wheel. Observe the scan tool Analog Steering Position Sensor data parameter for less than 180° or greater than -180°.
14. If not the specified value replace the SWPS.

Repair Procedures

Perform the **Diagnostic Repair Verification** after completing the diagnostic procedure.

- **Steering Wheel Position Sensor or Steering Shaft Lower Bearing Replacement**
- **Control Module References** for EBCM replacement, setup and programming

DTC U1651

Diagnostic Instructions

- Perform the **Diagnostic System Check - Vehicle** prior to using this diagnostic procedure.
- Review **Strategy Based Diagnosis** for an overview of the diagnostic approach.
- **Diagnostic Procedure Instructions** provides an overview of each diagnostic category.

DTC Descriptor

DTC U1651

Chassis System Dedicated Bus Sensor 1 Malfunction

Circuit/System Description

The yaw rate, lateral and longitudinal accelerometers are combined into one combination sensor external to the electronic brake control module (EBCM). The combination sensor receives ignition power and a ground that is separate from the EBCM. The combination sensor sends dedicated serial data messages to the EBCM regarding vehicle yaw rate, lateral and longitudinal acceleration.

Conditions for Running the DTC

The ignition is ON.

Conditions for Setting the DTC

- Ignition voltage to the yaw/lateral combination sensor is less than 9.5 volts.
- Communication is lost between the EBCM and the combination sensor.

Action Taken When the DTC Sets

- The EBCM disables the Antilock Brake System (ABS)/Traction Control System (TCS)/Vehicle Stability Enhancement System (VSES) for the duration of the ignition cycle.
- The ABS indicator turns ON.
- The driver information center (DIC) displays the ABS FAULT message.
- The Stability Caution indicator turns on.

2007 Hummer H3

2007 BRAKES Antilock Brake System - H3

- The DIC displays the SERVICE STAB SYS message.
- The DIC displays the TRACTION FAILED message.

Conditions for Clearing the DTC

- The condition for the DTC is no longer present and the DTC is cleared with a scan tool.
- The EBCM automatically clears the history DTC when a current DTC is not detected in 100 consecutive drive cycles.

Reference Information

Schematic Reference

Antilock Brake System Schematics

Connector End View Reference

Antilock Brake System Connector End Views

Description and Operation

ABS Description and Operation

Electrical Information Reference

- **Circuit Testing**
- **Connector Repairs**
- **Testing for Intermittent Conditions and Poor Connections**
- **Wiring Repairs**

Scan Tool Reference

- **Scan Tool Data List**
- **Scan Tool Data Definitions**

Circuit/System Verification

Verify that the following DTCs are not set: C0186 or C0196.

- If any of the DTCs are set, refer to **Diagnostic Trouble Code (DTC) List - Vehicle** .

Circuit/System Testing

2007 Hummer H3

2007 BRAKES Antilock Brake System - H3

1. Ignition OFF, disconnect the harness connector at the yaw rate/lateral and longitudinal accelerometer sensor.
2. Test for less than 1 ohm of resistance between the ground circuit terminal 4 and ground.
 - If greater than the specified range, test for an open/high resistance in the ground circuit.
3. Ignition ON, verify that a test lamp illuminates between the ignition circuit terminal 1 and ground.
 - If the test lamp does not illuminate, test the ignition circuit for a short to ground or an open/high resistance.
4. Ignition OFF, disconnect the C2 harness connector at the EBCM.
5. Ignition ON, test for 0 volts between the CAN HI circuit terminal 11 and ground.
 - If greater than the specified value, test the CAN HI circuit for a short to voltage.
6. Test for 0 volts between the CAN LO circuit terminal 25 and ground.
 - If greater than the specified value, test the CAN LO circuit for a short to voltage.
7. Ignition OFF, test for infinite resistance between the CAN HI circuit terminal 11 and ground.
 - If not the specified value, test the suspect circuit for a short to ground.
8. Test for infinite resistance between the CAN LO circuit terminal 25 and ground.
 - If not the specified value, test the CAN LO circuit for a short to ground.
9. Test for less than 1 ohm of resistance between the CAN HI circuit terminal 11 and terminal 2.
 - If greater than the specified range, test the CAN HI circuit for an open/high resistance.
10. Test for less than 1 ohm of resistance between the CAN LO circuit terminal 3 and terminal 25.
 - If greater than the specified range, test the CAN LO circuit for an open/high resistance.
11. Test for infinite resistance between the CAN HI terminal 11 and the CAN LO terminal 25.
 - If not the specified value, test the CAN HI and CAN LO circuits for a short together.
12. If all circuits test normal, replace the Yaw Rate/Lateral sensor.

Repair Procedures

Perform the **Diagnostic Repair Verification** after completing the diagnostic procedure.

Vehicle Yaw Sensor with Vehicle Lateral and Longitudinal Accelerometer Replacement

SYMPTOMS - ANTILOCK BRAKE SYSTEM

IMPORTANT: The following steps must be completed before using the symptom tables.

1. Perform the ABS Diagnostic System Check before using the symptom tables in order to verify that all of the following are true:
 - There are no DTCs set.
 - The control modules can communicate via the serial data link.
2. Review the system description and operation in order to familiarize yourself with the system functions. Refer to ABS Description and Operation.

Visual/Physical Inspection

- Inspect for aftermarket devices which could affect the operation of the ABS. Refer to Checking Aftermarket Accessories .
- Inspect the easily accessible or visible system components for obvious damage or conditions which could cause the symptom.

Intermittent

Faulty electrical connections or wiring may be the cause of intermittent conditions. Refer to Testing for Intermittent Conditions and Poor Connections .

Symptom List

Refer to a symptom diagnostic procedure from the following list in order to diagnose the symptom:

- ABS Indicator Always On
- ABS Indicator Inoperative
- Stability System Caution Indicator Always On
- Stability System Caution Indicator Inoperative
- Traction Off Indicator Always On
- Traction Off Indicator Inoperative
- Vehicle Stability Enhancement System Poor Performance

Diagnostic Fault Information

IMPORTANT: Always perform the Diagnostic System Check - Vehicle prior to using this diagnostic procedure.

Circuit/System Description

The instrument panel cluster (IPC) illuminates the Antilock Brake System (ABS) indicator by supplying ground to the lamp. The electronic brake control module (EBCM) sends a serial data messages to the IPC, in order to command the indicator ON or OFF.

Circuit/System Testing

Note: Diagnose all vehicle DTCs before using this diagnostic.

With the scan tool, select instrument panel special functions Lamp Test. Command the instrument panel warning lamps OFF.

- If the ABS warning lamp does not turn OFF, replace the IPC.
- If the ABS lamp turns off and there are no DTCs stored in any vehicle systems, replace the EBCM.

Repair Procedures

IMPORTANT: Always perform the Diagnostic Repair Verification after completing the diagnostic procedure.

Control Module References for EBCM or IPC replacement, setup and programming

ABS INDICATOR INOPERATIVE

Diagnostic Fault Information

IMPORTANT: Always perform the Diagnostic System Check - Vehicle prior to using this diagnostic procedure.

Circuit/System Description

The instrument panel cluster (IPC) illuminates the Antilock Brake System (ABS) indicator by supplying ground to the lamp. The electronic brake control module (EBCM) sends a serial data messages to the IPC, in order to command the indicator ON or OFF.

Circuit/System Testing

Note: Diagnose all vehicle DTCs before using this diagnostic.

With the scan tool, select instrument panel special functions Lamp Test. Command the instrument panel warning lamps ON.

- If the ABS warning lamp does not turn on, replace the IPC.

Repair Procedures

IMPORTANT: Always perform the Diagnostic Repair Verification after completing the diagnostic procedure.

Control Module References for EBCM or IPC replacement, setup and programming

STABILITY SYSTEM CAUTION INDICATOR ALWAYS ON

Diagnostic Fault Information

IMPORTANT: Always perform the Diagnostic System Check - Vehicle prior to using this diagnostic procedure.

Circuit/System Description

The instrument panel cluster (IPC) illuminates the stability system caution indicator by supplying ground to the lamp. The electronic brake control module (EBCM) sends a serial data messages to the IPC, in order to command the indicator ON or OFF.

Circuit/System Testing

Note: Diagnose all vehicle DTCs before using this diagnostic.

With the scan tool, select instrument panel special functions Lamp Test. Command the instrument panel warning lamps OFF.

- If the stability system caution indicator lamp does not turn off, replace the IPC.
- If the stability system caution indicator lamp turns off and there are no DTCs stored in any vehicle systems, replace the EBCM.

Repair Procedures

IMPORTANT: Always perform the Diagnostic Repair Verification after completing the diagnostic procedure.

Control Module References for EBCM and IPC replacement, setup and programming

STABILITY SYSTEM CAUTION INDICATOR INOPERATIVE

Diagnostic Fault Information

IMPORTANT: Always perform the Diagnostic System Check - Vehicle prior to using this diagnostic procedure.

Circuit/System Description

The instrument panel cluster (IPC) illuminates the stability system caution indicator by supplying ground to the lamp. The electronic brake control module (EBCM) sends a serial data messages to the IPC, in order to command the indicator ON or OFF.

Circuit/System Testing

Note: Diagnose all vehicle DTCs before using this diagnostic.

With the scan tool, select instrument panel special functions Lamp Test. Command the instrument panel warning lamps ON.

- If the stability system caution indicator does not turn on, replace the IPC.

Repair Procedures

IMPORTANT: Always perform the Diagnostic Repair Verification after completing the diagnostic procedure.

Control Module References for EBCM and IPC replacement, setup and programming

TRACTION OFF INDICATOR ALWAYS ON

Diagnostic Fault Information

IMPORTANT: Always perform the Diagnostic System Check - Vehicle prior to using this diagnostic procedure.

Circuit/System Description

2007 Hummer H3

2007 BRAKES Antilock Brake System - H3

The instrument panel cluster (IPC) illuminates the traction off indicator by supplying ground to the lamp. The electronic brake control module (EBCM) sends a serial data messages to the IPC, in order to command the indicator ON or OFF.

Circuit/System Testing

Note: Diagnose all vehicle DTCs before using this diagnostic.

With the scan tool, select instrument panel special functions Lamp Test. Command the instrument panel warning lamps OFF.

- If the traction off indicator does not turn off, replace the IPC.
- If the traction off indicator turns off and there are no DTCs stored in any vehicle systems, replace the EBCM.

Repair Procedures

IMPORTANT: Always perform the Diagnostic Repair Verification after completing the diagnostic procedure.

Control Module References for EBCM or IPC replacement, setup and programming

TRACTION OFF INDICATOR INOPERATIVE

Diagnostic Fault Information

IMPORTANT: Always perform the Diagnostic System Check - Vehicle prior to using this diagnostic procedure.

Circuit/System Description

The instrument panel cluster (IPC) illuminates the traction off indicator by supplying ground to the lamp. The electronic brake control module (EBCM) sends a serial data messages to the IPC, in order to command the indicator ON or OFF.

Circuit/System Testing

Note: Diagnose all vehicle DTCs before using this diagnostic.

1. With the scan tool, select instrument panel special functions Lamp Test. Command the instrument panel warning lamps ON.
 - If the ABS warning lamp does not turn on, replace the IPC.

2. Turn the ignition OFF. Disconnect the traction control switch harness connector. Turn the ignition ON. Touch and release a 3-amp fused jumper wire between ground and the Traction Control System (TCS) switch signal circuit.
 - If the traction off indicator illuminates, replace the traction control switch.
3. Disconnect the body control module (BCM) harness connector. Touch and release a 3-amp fused jumper wire between ground and the TCS switch signal circuit at the BCM.
 - If the traction off indicator illuminates, repair an open in the TCS switch signal circuit.
 - If the traction off indicator does not illuminate replace the BCM.

Repair Procedures

IMPORTANT: Always perform the Diagnostic Repair Verification after completing the diagnostic procedure.

Control Module References for EBCM, IPC or BCM replacement, setup and programming

VEHICLE STABILITY ENHANCEMENT SYSTEM POOR PERFORMANCE

Diagnostic Instructions

- Perform the **Diagnostic System Check - Vehicle** prior to using this diagnostic procedure.
- Review **Strategy Based Diagnosis** for an overview of the diagnostic approach.
- **Diagnostic Procedure Instructions** provides an overview of each diagnostic category.

Circuit/System Description

Proper operation of the Vehicle Stability Enhancement System (VSES) is highly dependent on the ability to apply brake pressure to a selected wheel, through the brake pressure modulator valve (BPMV), as commanded by the electronic brake control module (EBCM). The EBCM may not be able to detect certain mechanical failures that may cause the VSES to perform poorly. This diagnostic procedure is designed to help diagnose concerns of poor vehicle stability that may occur without the presence of any DTCs, by verifying the following:

- The tires are the correct size, properly inflated and in acceptable condition.
- There are no mechanical problems in the steering system.
- There are no mechanical problems in the suspension system.
- There are no mechanical problems in the base brake system.
- There are no mechanical problems in the locking differential or transfer case.
- All of the VSES related hydraulic controls within the BPMV are functioning correctly.

Repair Procedures

Perform the **Diagnostic Repair Verification** after completing the diagnostic procedure.

- **Symptoms - Antilock Brake System**
- **Symptoms - Hydraulic Brakes**
- **Symptoms - Locking/Limited Slip Rear Axle**
- **Symptoms - Steering Wheel and Column**
- **Symptoms - Suspension General Diagnosis**

REPAIR INSTRUCTIONS

ANTILOCK BRAKE SYSTEM AUTOMATED BLEED PROCEDURE (WITHOUT RPO BRM)

CAUTION: Refer to **Brake Fluid Irritant Caution** .

CAUTION: Do not remove the reservoir cap while depressing and releasing the brake pedal. If the cap is removed while depressing and releasing the brake pedal, pressurized brake fluid being returned to the reservoir may leave the reservoir. Personal injury or vehicle damage could result.

NOTE: Refer to **Brake Fluid Effects on Paint and Electrical Components Notice** .

NOTE: When adding fluid to the brake master cylinder reservoir, use only Delco Supreme 11[®], GM P/N 12377967 (Canadian P/N 992667) or equivalent DOT-3 brake fluid from a clean, sealed brake fluid container. The use of any type of fluid other than the recommended type of brake fluid, may cause contamination which could result in damage to the internal rubber seals and/or rubber linings of hydraulic brake system components.

NOTE: Do Not allow the HBCi pump and motor to run more than 1 minute continuously. Allow 2 minutes cool down time between pump run times. Extended pump and motor run time could create excessive heat and damage the pump and motor assembly.

IMPORTANT: Perform steps 1-4 below to bleed the HBCi accumulator circuit prior to performing a base brake bleed.

1. Turn the ignition ON. Allow the pump and motor to run as required. The pump and motor will stop automatically and may run up to 10 seconds.
2. Depress the brake pedal 4 times.
3. Confirm that brake fluid returns to the reservoir.
4. Repeat steps 1-3 until all air is purged from the accumulator circuit (return fluid is clear and free from air).

IMPORTANT: The base hydraulic brake system must be bled before proceeding. If you have not yet performed the base hydraulic brake system bleeding procedure, refer to Hydraulic Brake System Bleeding (Manual) or Hydraulic Brake System Bleeding (Pressure) for hydraulic brakes before proceeding.

5. With the ignition OFF, depress and release the brake pedal 20 times to deplete accumulator pressure. If the brake fluid clouds and has air mixed with the fluid, wait until the fluid clears to proceed.
6. Turn the ignition ON and depress the pedal 20 times quickly. The pump and motor will be activated.
7. Turn the ignition OFF and repeat step 5 again. If the brake fluid clouds and has air mixed with the fluid, wait until the fluid clears to proceed.
8. Turn the ignition ON to activate the pump and motor. Allow the pump and motor to stop automatically. The pump and motor will run about 10 seconds.
9. Install a scan tool to the vehicle.
10. Start the engine and allow the engine to idle.
11. Depress the brake pedal firmly and maintain steady pressure on the pedal.
12. Using the scan tool, begin the automated bleed procedure.
13. Follow the instructions on the scan tool to complete the automated bleed procedure. Release the brake pedal between each test sequence.
14. Turn the ignition OFF.
15. Remove the scan tool from the vehicle.
16. Fill the brake master cylinder reservoir to the maximum-fill level with Delco Supreme 11® GM P/N 12377967 (Canadian P/N 992667) or equivalent DOT-3 brake fluid from a clean, sealed brake fluid container.

2007 Hummer H3

2007 BRAKES Antilock Brake System - H3

17. Bleed the hydraulic brake system. Refer to **Hydraulic Brake System Bleeding (Manual)** or **Hydraulic Brake System Bleeding (Pressure)** for hydraulic brakes.
18. With the ignition OFF, apply the brakes 20 times or until the brake pedal becomes firm, in order to deplete the brake booster power reserve.
19. Slowly depress and release the brake pedal. Observe the feel of the brake pedal.
20. If the pedal feels spongy, repeat the automated bleeding procedure. If the brake pedal still feels spongy after repeating the automated bleeding procedure inspect the brake system for external leaks. Refer to **Brake System External Leak Inspection** .
21. Turn the ignition key ON, with the engine OFF; check to see if the brake system warning lamp remains illuminated.
22. If the brake system warning lamp remains illuminated, DO NOT allow the vehicle to be driven until it is diagnosed and repaired. Refer to **Symptoms - Hydraulic Brakes** for hydraulic brakes.
23. Drive the vehicle to exceed 13 kph (8 mph) to allow ABS initialization to occur. Observe brake pedal feel.
24. If the brake pedal feels spongy, repeat the automated bleeding procedure until a firm brake pedal is obtained.

ANTILOCK BRAKE SYSTEM AUTOMATED BLEED PROCEDURE (WITH RPO BRM)

CAUTION: Refer to DOT 4 BRAKE FLUID CAUTION .

CAUTION: Refer to Brake Fluid Irritant Caution .

CAUTION: Do not remove the reservoir cap while depressing and releasing the brake pedal. If the cap is removed while depressing and releasing the brake pedal, pressurized brake fluid being returned to the reservoir may leave the reservoir. Personal injury or vehicle damage could result.

NOTE: Refer to Brake Fluid Effects on Paint and Electrical Components Notice .

NOTE: When adding fluid to the brake master cylinder reservoir, use only GM Vehicle Care Brake and Clutch Fluid Super DOT-4, GM P/N

88958860 (Canadian P/N 88901244) or equivalent DOT-4 brake fluid from a clean, sealed container. The use of any type of fluid other than the recommended type of brake fluid, may cause contamination which could result in damage to the internal rubber seals and/or rubber linings of hydraulic brake system components.

NOTE: Do Not allow the HBCi pump and motor to run more than 1 minute continuously. Allow 2 minutes cool down time between pump run times. Extended pump and motor run time could create excessive heat and damage the pump and motor assembly.

IMPORTANT: Perform steps 1-4 below to bleed the HBCi accumulator circuit prior to performing a base brake bleed.

1. Turn the ignition ON. Allow the pump and motor to run as required. The pump and motor will stop automatically and may run up to 10 seconds.
2. Depress the brake pedal 4 times.
3. Confirm that brake fluid returns to the reservoir.
4. Repeat steps 1-3 until all air is purged from the accumulator circuit (return fluid is clear and free from air).

IMPORTANT: The base hydraulic brake system must be bled before proceeding. If you have not yet performed the base hydraulic brake system bleeding procedure, refer to Hydraulic Brake System Bleeding (Manual) or Hydraulic Brake System Bleeding (Pressure) for hydraulic brakes before proceeding.

5. With the ignition OFF, depress and release the brake pedal 20 times to deplete accumulator pressure. If the brake fluid clouds and has air mixed with the fluid, wait until the fluid clears to proceed.
6. Turn the ignition ON and depress the pedal 20 times quickly. The pump and motor will be activated.
7. Turn the ignition OFF and repeat step 5 again. If the brake fluid clouds and has air mixed with the fluid, wait until the fluid clears to proceed.
8. Turn the ignition ON to activate the pump and motor. Allow the pump and motor to stop automatically. The pump and motor will run about 10 seconds.
9. Install a scan tool to the vehicle.

2007 Hummer H3

2007 BRAKES Antilock Brake System - H3

10. Start the engine and allow the engine to idle.
11. Depress the brake pedal firmly and maintain steady pressure on the pedal.
12. Using the scan tool, begin the automated bleed procedure.
13. Follow the instructions on the scan tool to complete the automated bleed procedure. Release the brake pedal between each test sequence.
14. Turn the ignition OFF.
15. Remove the scan tool from the vehicle.
16. Fill the brake master cylinder reservoir to the maximum-fill level with brake and clutch fluid Super DOT-4 GM P/N 88958860 (Canadian P/N 88901244) or equivalent DOT-4 brake fluid from a clean, sealed brake fluid container.
17. Bleed the hydraulic brake system. Refer to **Hydraulic Brake System Bleeding (Manual)** or **Hydraulic Brake System Bleeding (Pressure)** for hydraulic brakes.
18. With the ignition OFF, apply the brakes 20 times or until the brake pedal becomes firm, in order to deplete the brake booster power reserve.
19. Slowly depress and release the brake pedal. Observe the feel of the brake pedal.
20. If the pedal feels spongy, repeat the automated bleeding procedure. If the brake pedal still feels spongy after repeating the automated bleeding procedure inspect the brake system for external leaks. Refer to **Brake System External Leak Inspection** .
21. Turn the ignition key ON, with the engine OFF; check to see if the brake system warning lamp remains illuminated.
22. If the brake system warning lamp remains illuminated, DO NOT allow the vehicle to be driven until it is diagnosed and repaired. Refer to **Symptoms - Hydraulic Brakes** for hydraulic brakes.
23. Drive the vehicle to exceed 13 kph (8 mph) to allow ABS initialization to occur. Observe brake pedal feel.
24. If the brake pedal feels spongy, repeat the automated bleeding procedure until a firm brake pedal is obtained.

BRAKE MASTER CYLINDER WITH POWER BRAKE BOOSTER AND CHASSIS CONTROL MODULE REPLACEMENT (LHD)

Removal Procedure

CAUTION: Refer to Brake Fluid Irritant Caution .

NOTE: Refer to Brake Fluid Effects on Paint and Electrical Components

Notice .

1. Apply and release the brake pedal 20 times to deplete the hydraulic brake booster accumulator reserve.

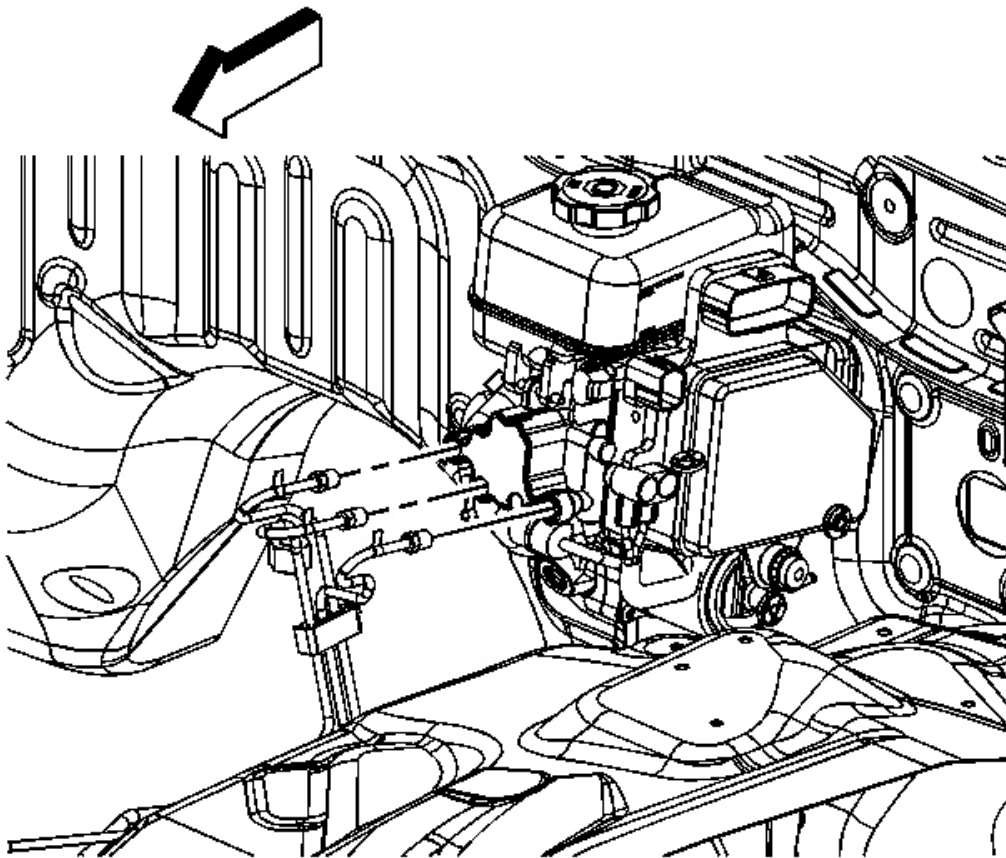

Fig. 22: Identifying Rear And Left Front Brake Pipes At Brake Master Cylinder
Courtesy of GENERAL MOTORS CORP.

2. Remove the rear and left front brake pipes from the brake master cylinder.

Cap the brake pipe fittings and plug the master cylinder outlet ports to prevent brake fluid loss and contamination.

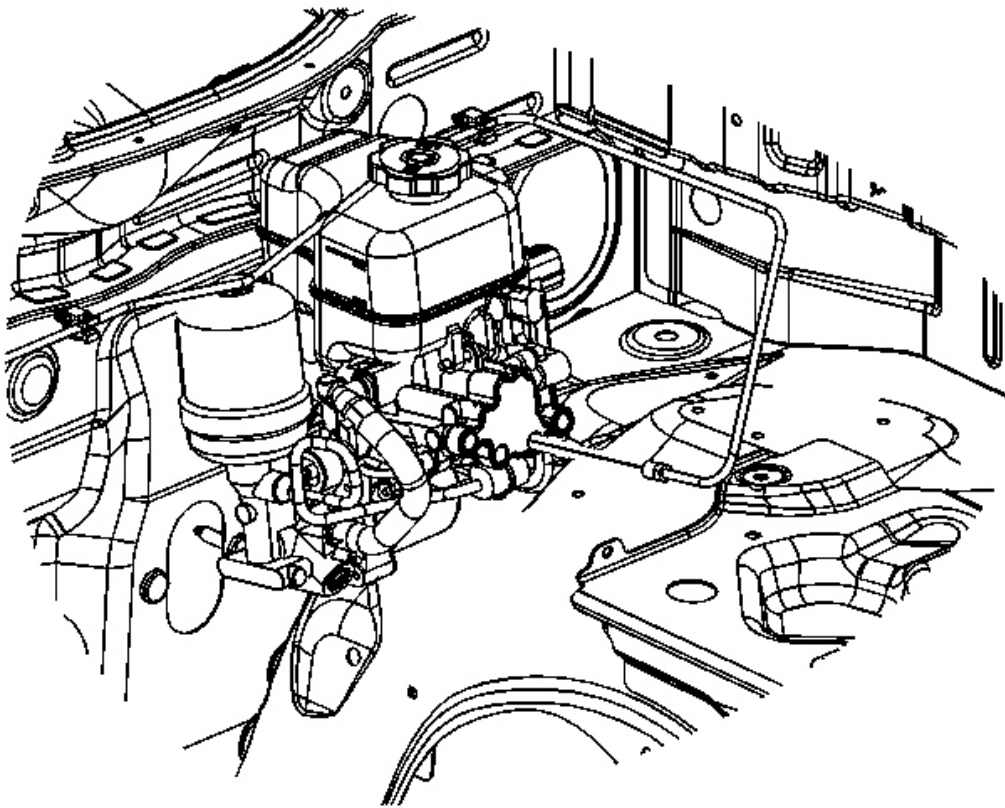

Fig. 23: Identifying Right Front Brake Pipe At Brake Master Cylinder
Courtesy of GENERAL MOTORS CORP.

3. Remove the right front brake pipe from the brake master cylinder.

Cap the brake pipe fittings and plug the master cylinder outlet ports to prevent brake fluid loss and contamination.

4. Disconnect the electrical connectors at the brake pressure modulator valve (BPMV).
5. Disconnect the electrical connector for the fluid level sensor.
6. Remove the knee bolster. Refer to **Driver Knee Bolster Replacement (Left Hand Drive)** or **Driver Knee Bolster Replacement (Right Hand Drive)** .
7. Remove the knee bolster bracket. Refer to **Driver Knee Bolster Bracket Replacement (Left Hand Drive)** or **Driver Knee Bolster Bracket Replacement (Right Hand**

Drive) .

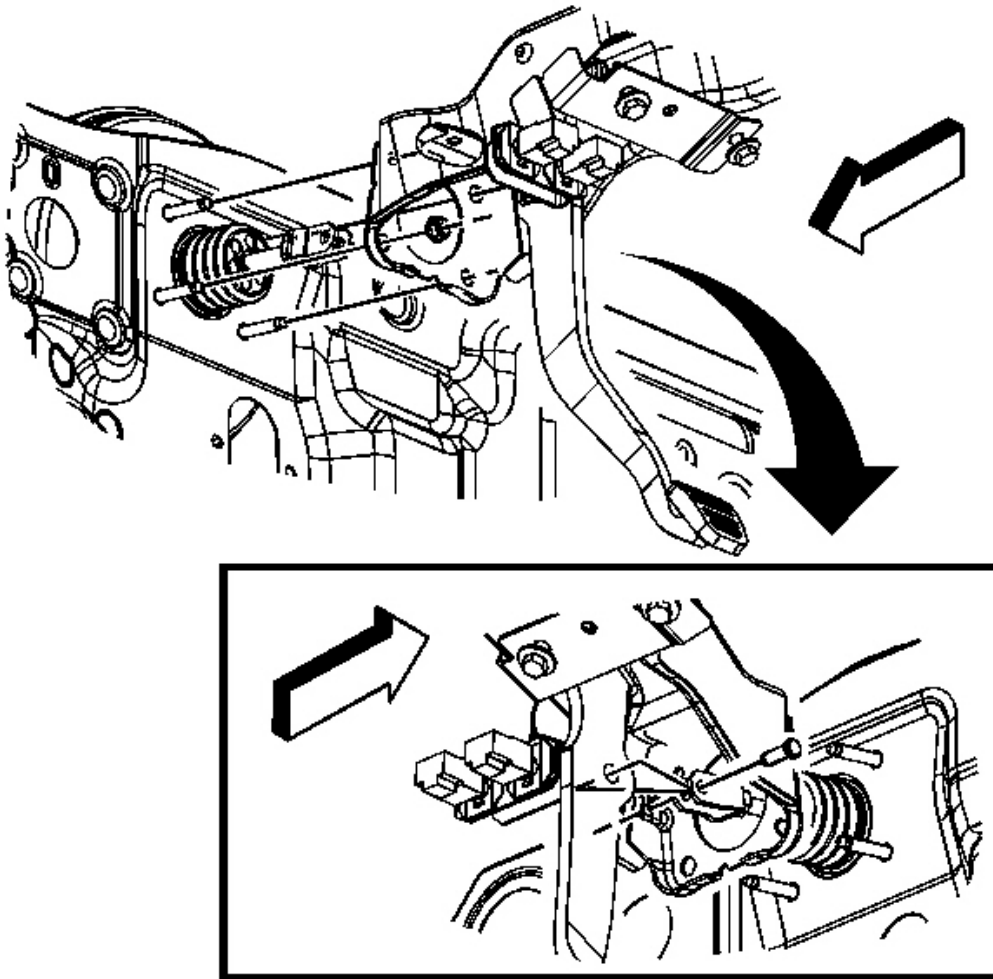

Fig. 24: Locating Clevis Pin At Master Cylinder Push Rod
Courtesy of GENERAL MOTORS CORP.

8. Remove the retainer from the clevis pin.
9. Remove the clevis pin from the master cylinder push rod and the brake pedal.

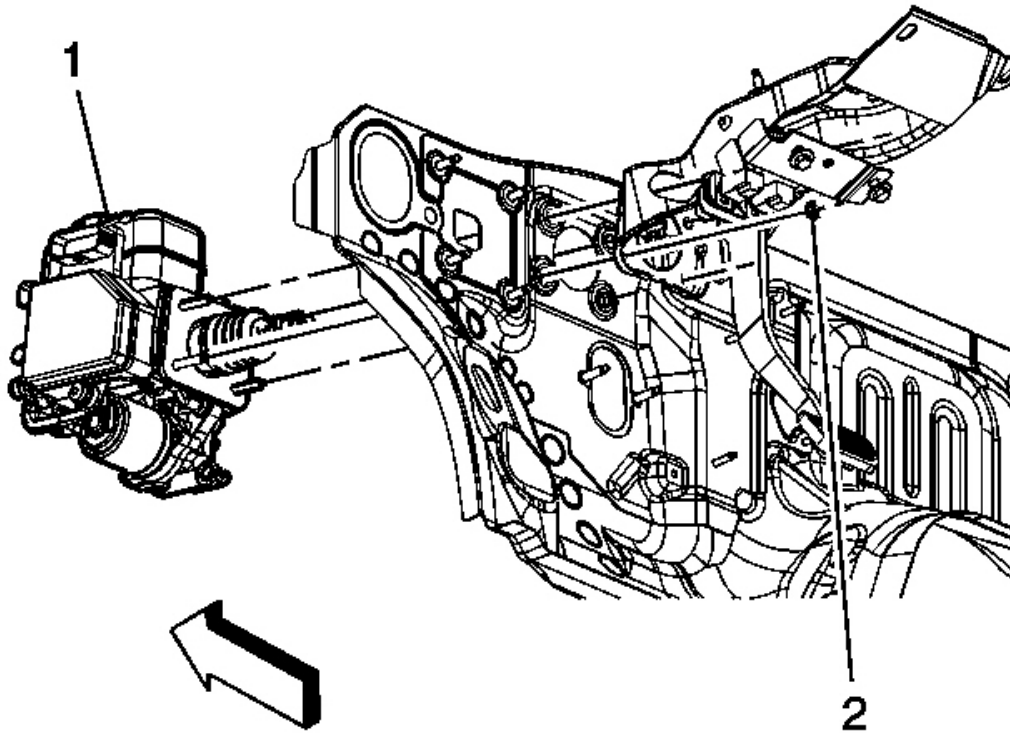

Fig. 25: Master Cylinder Removal/Installation
Courtesy of GENERAL MOTORS CORP.

IMPORTANT: It may be necessary to reposition or remove some of the wiring harnesses from their retainers to provide clearance to remove the mounting nuts for the brake master cylinder assembly.

10. Remove the mounting nuts for the brake master cylinder (2).
11. Remove the brake master cylinder and power brake booster assembly (1).

Installation Procedure

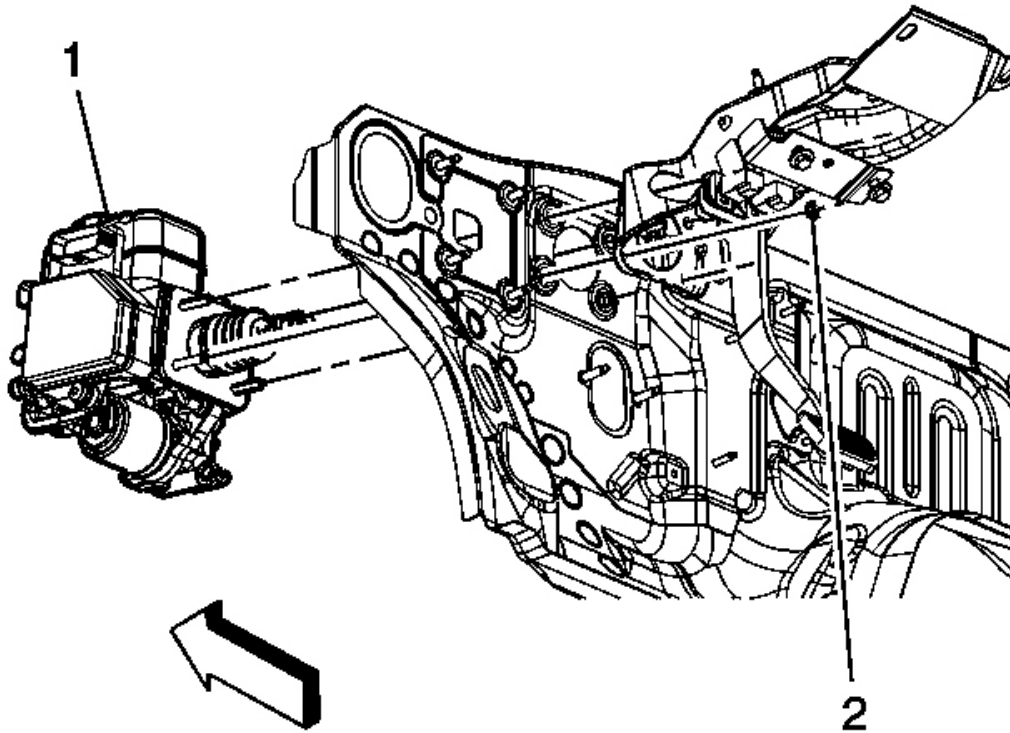

Fig. 26: Master Cylinder Removal/Installation
Courtesy of GENERAL MOTORS CORP.

1. Install the brake master cylinder and power brake booster assembly (1).

NOTE: Refer to Fastener Notice .

2. Install the master cylinder nuts (2).

Tighten: Tighten the nuts to 30 N.m (22 lb ft).

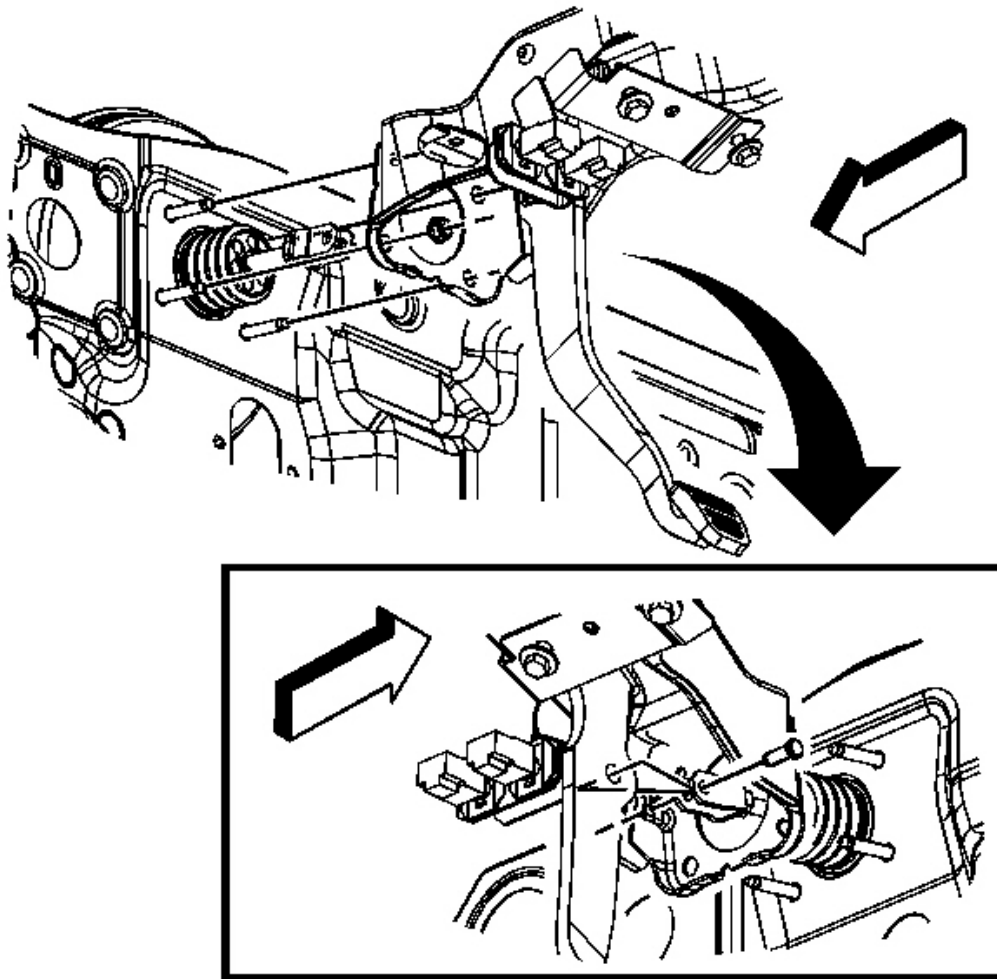

Fig. 27: Locating Clevis Pin At Master Cylinder Push Rod
Courtesy of GENERAL MOTORS CORP.

3. Install the clevis pin to the master cylinder push rod and the brake pedal.
4. Install the retainer to the clevis pin.
5. Install the knee bolster bracket. Refer to **Driver Knee Bolster Bracket Replacement (Left Hand Drive)** or **Driver Knee Bolster Bracket Replacement (Right Hand Drive)** .
6. Install the knee bolster. Refer to **Driver Knee Bolster Replacement (Left Hand Drive)** or **Driver Knee Bolster Replacement (Right Hand Drive)** .

7. Connect the electrical connector for the brake fluid level sensor.
8. Connect the electrical connectors at the BPMV.

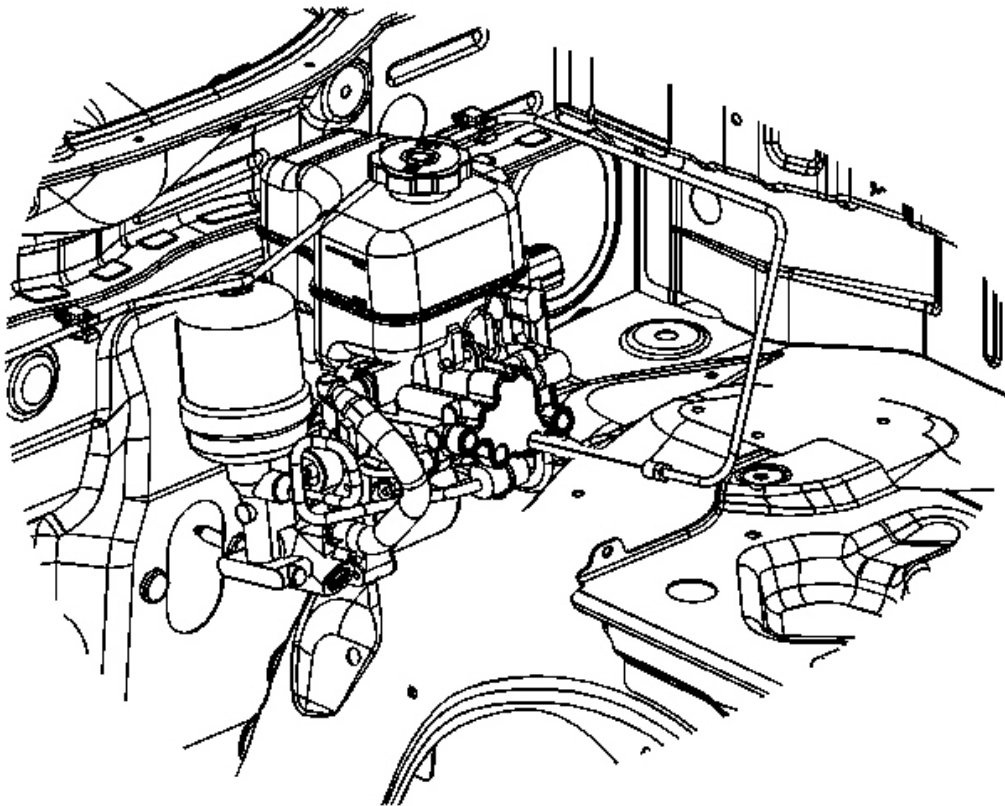

Fig. 28: Identifying Right Front Brake Pipe At Brake Master Cylinder
Courtesy of GENERAL MOTORS CORP.

9. Install the right front brake pipe fitting to the master cylinder.

Tighten: Tighten the fittings to 19 N.m (14 lb ft).

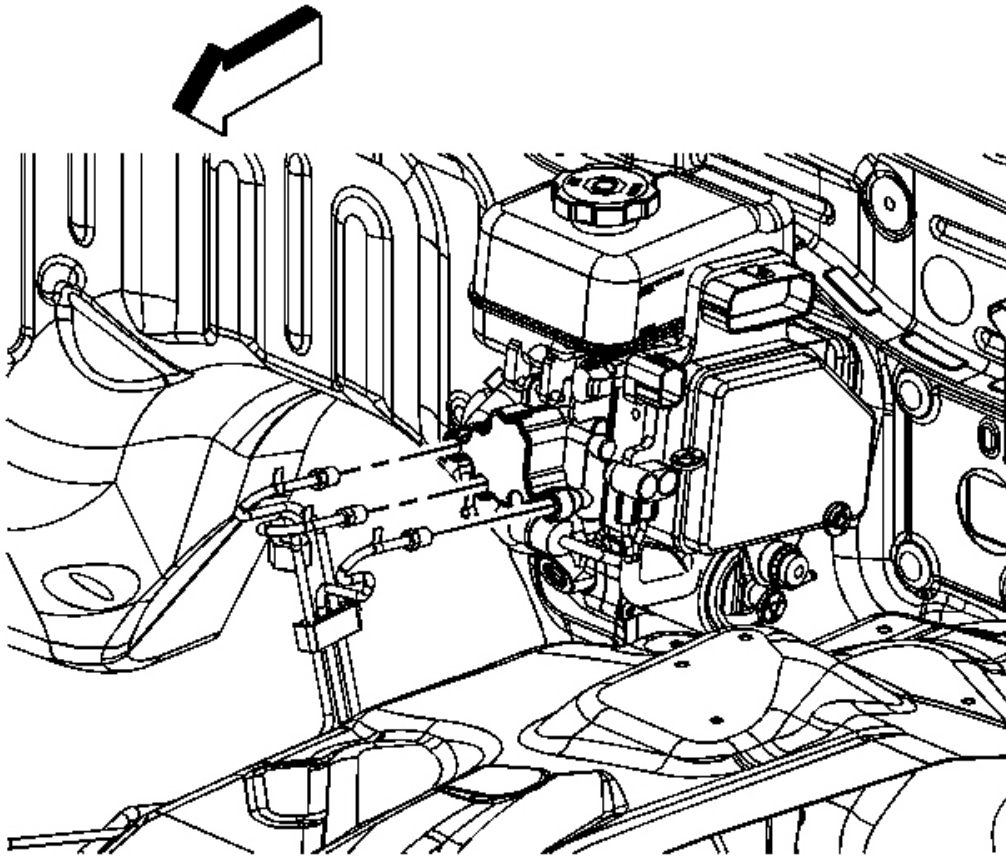

Fig. 29: Identifying Rear And Left Front Brake Pipes At Brake Master Cylinder
Courtesy of GENERAL MOTORS CORP.

10. Install the rear and left front brake pipe fittings to the brake master cylinder.

Tighten: Tighten the fittings to 19 N.m (14 lb ft).

11. Adjust the stop lamp switch. Refer to **Stop Lamp Switch Adjustment** .
12. Bleed the brake system. Refer to **Hydraulic Brake System Bleeding (Manual)** or **Hydraulic Brake System Bleeding (Pressure)** .

Removal Procedure

CAUTION: Refer to Brake Fluid Irritant Caution .

NOTE: Refer to Brake Fluid Effects on Paint and Electrical Components Notice .

1. Apply and release the brake pedal at least 20 times to release the power brake accumulator reserve pressure.
2. Mark the location of the brake pipes to the master cylinder.

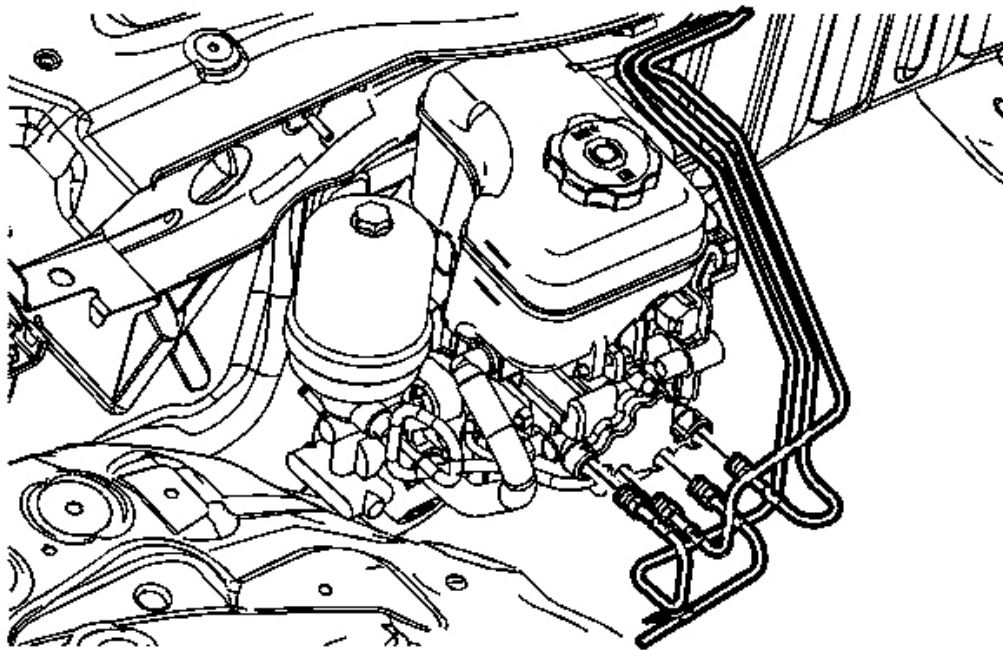

Fig. 30: View Of Brake Pipe Fittings & The Master Cylinder
Courtesy of GENERAL MOTORS CORP.

3. Disconnect the 4 brake pipe fittings from the master cylinder.

Cap the brake pipe fittings and plug the master cylinder outlet ports to prevent brake fluid

loss and contamination.

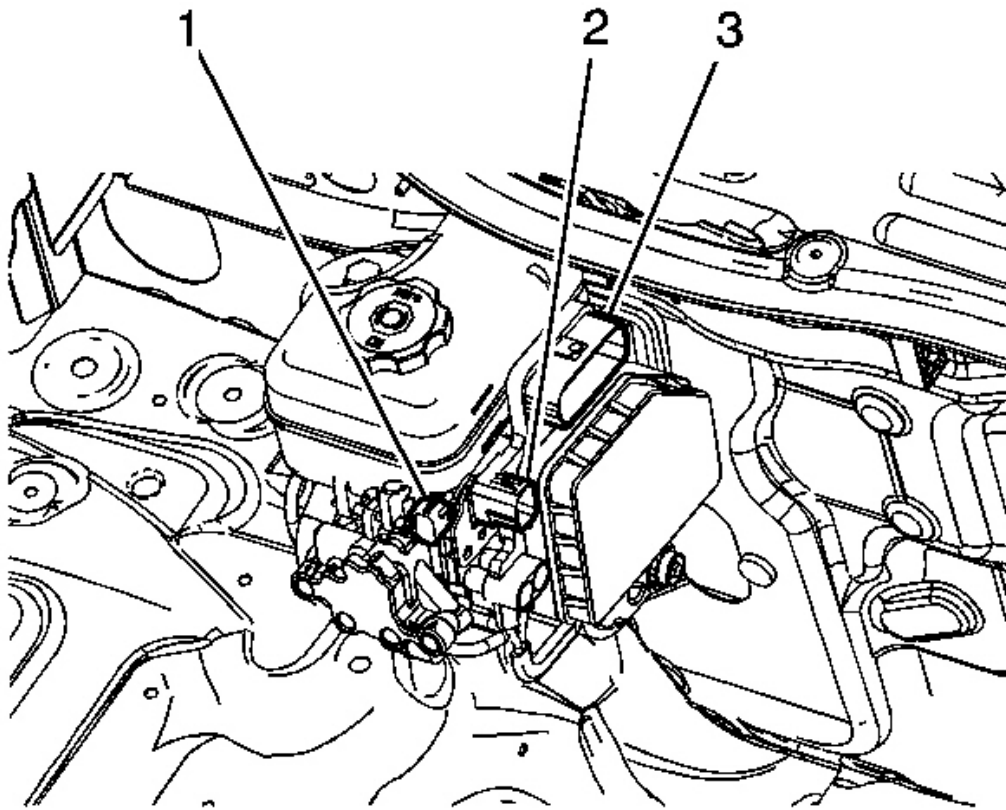

Fig. 31: Identifying Brake Fluid Level Sensor
Courtesy of GENERAL MOTORS CORP.

4. Disconnect the brake fluid level sensor (1) electrical connector.
5. Disconnect the electrical connectors (2) and (3) at the brake pressure modulator valve (BPMV) and module assembly.
6. Remove the driver knee bolster bracket. Refer to **Driver Knee Bolster Bracket Replacement (Left Hand Drive)** or **Driver Knee Bolster Bracket Replacement (Right Hand Drive)** .

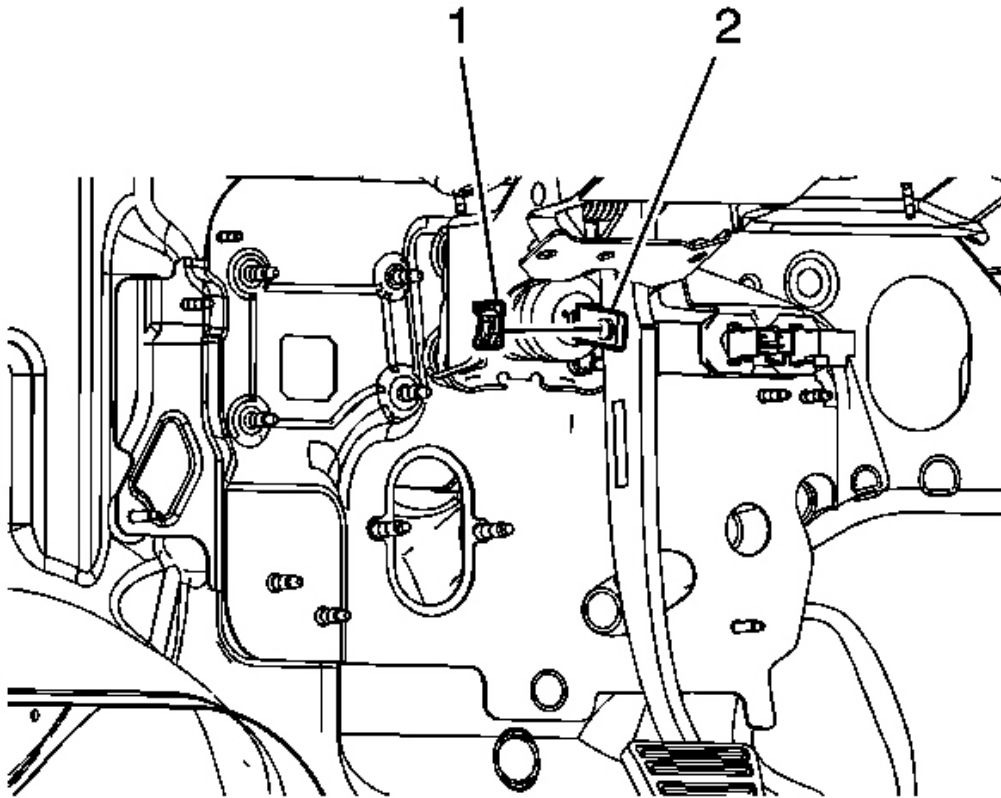

Fig. 32: View Of Retainer & Clevis Pin
Courtesy of GENERAL MOTORS CORP.

7. Remove the retainer (1) from the clevis pin.
8. Remove the clevis pin (2) from the master cylinder pushrod and the brake pedal.

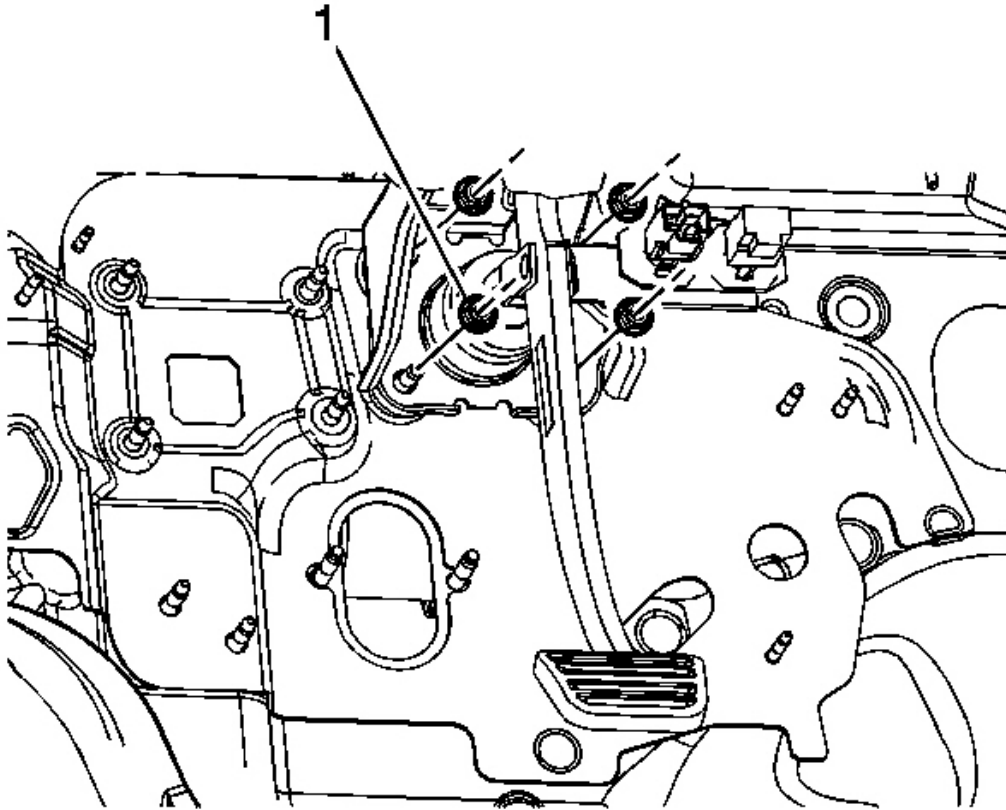

Fig. 33: Identifying Master Cylinder Nuts
Courtesy of GENERAL MOTORS CORP.

9. Remove the 4 master cylinder nuts (1).

Reposition any wiring harnesses as necessary to improve access to the master cylinder nuts.

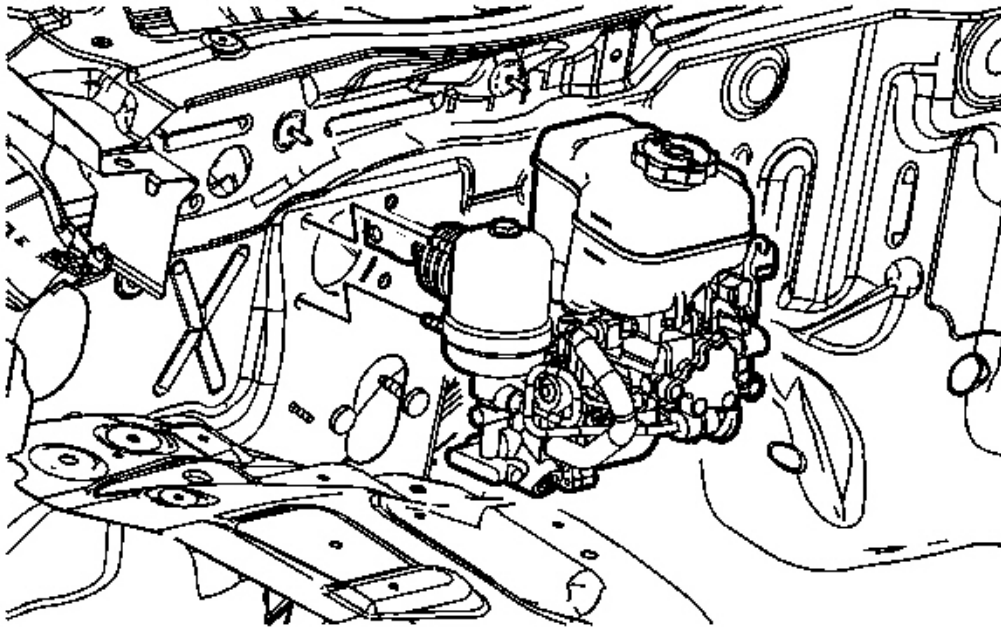

Fig. 34: Removing/Installing Master Cylinder/Power Brake Booster Assembly
Courtesy of GENERAL MOTORS CORP.

10. Remove the master cylinder with power brake booster assembly.

Installation Procedure

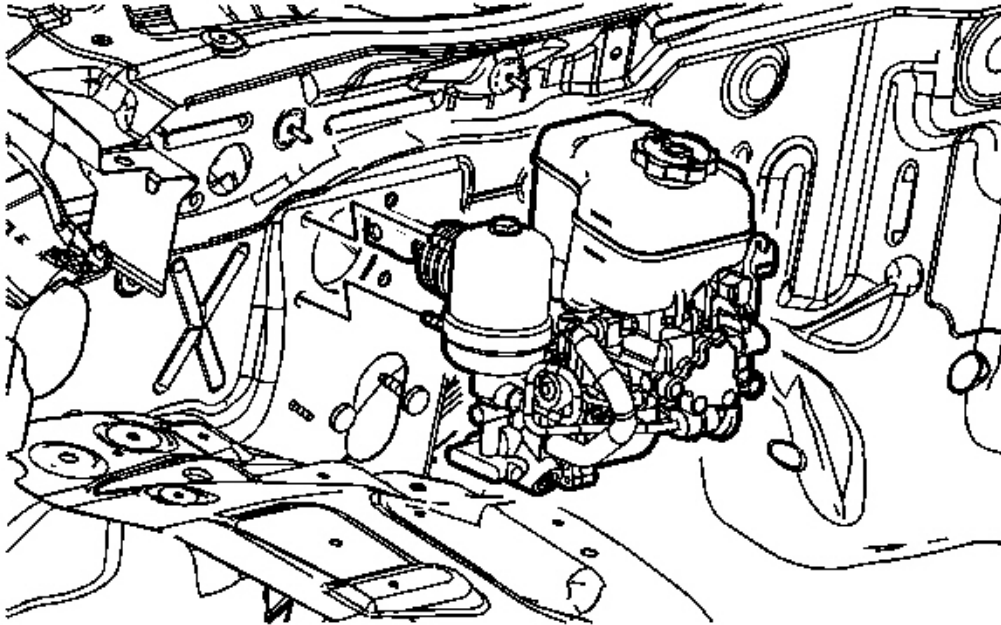

Fig. 35: Removing/Installing Master Cylinder/Power Brake Booster Assembly
Courtesy of GENERAL MOTORS CORP.

1. Install the master cylinder with power brake booster assembly.

NOTE: Refer to Fastener Notice .

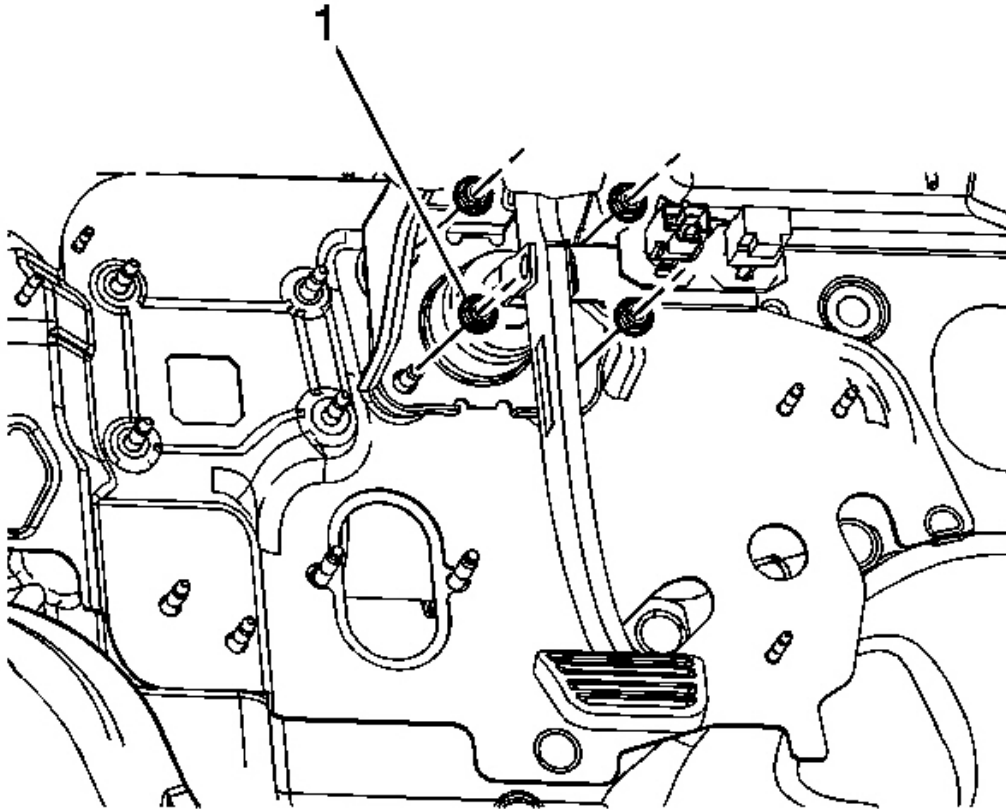

Fig. 36: Identifying Master Cylinder Nuts
Courtesy of GENERAL MOTORS CORP.

2. Install the 4 master cylinder nuts (1).

Tighten: Tighten the nuts to 27 N.m (20 lb ft).

3. Position any wiring harnesses which were moved to access the master cylinder nuts to the retainers.

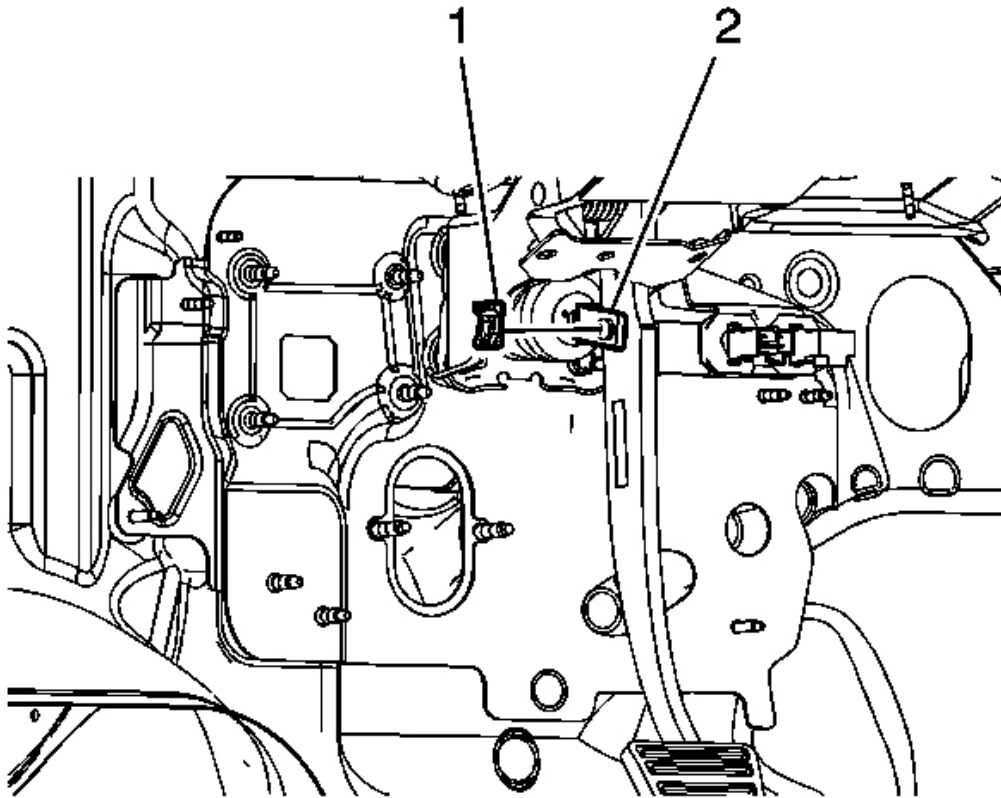

Fig. 37: View Of Retainer & Clevis Pin
Courtesy of GENERAL MOTORS CORP.

4. Install the clevis pin (2) to the master cylinder pushrod and the brake pedal.
5. Install the retainer (1) to the clevis pin.
6. Verify the correct installation of the retainer by rotating the retainer 360 degrees.

The retainer must rotate freely and not become disengaged from the groove in the clevis pin.

7. Install the driver knee bolster bracket. Refer to **Driver Knee Bolster Bracket Replacement (Left Hand Drive)** or **Driver Knee Bolster Bracket Replacement (Right Hand Drive)** .

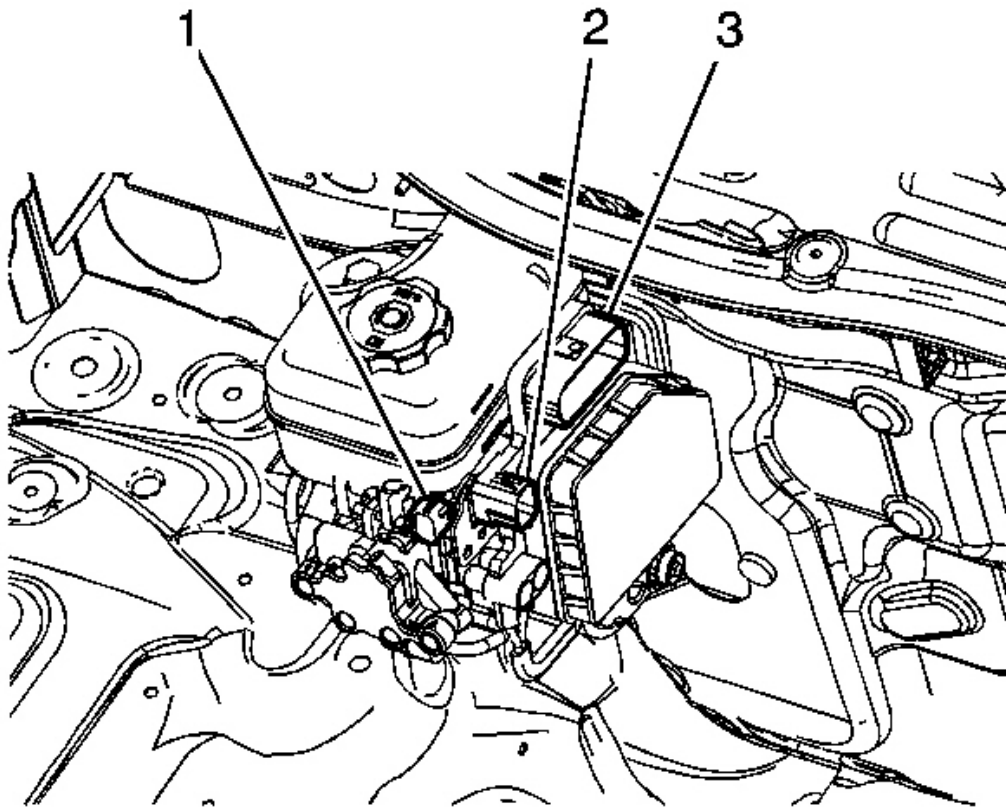

Fig. 38: Identifying Brake Fluid Level Sensor
Courtesy of GENERAL MOTORS CORP.

8. Connect the brake fluid level sensor (1) electrical connector.
9. Connect the electrical connectors (2) and (3) at the BPMV and module assembly.

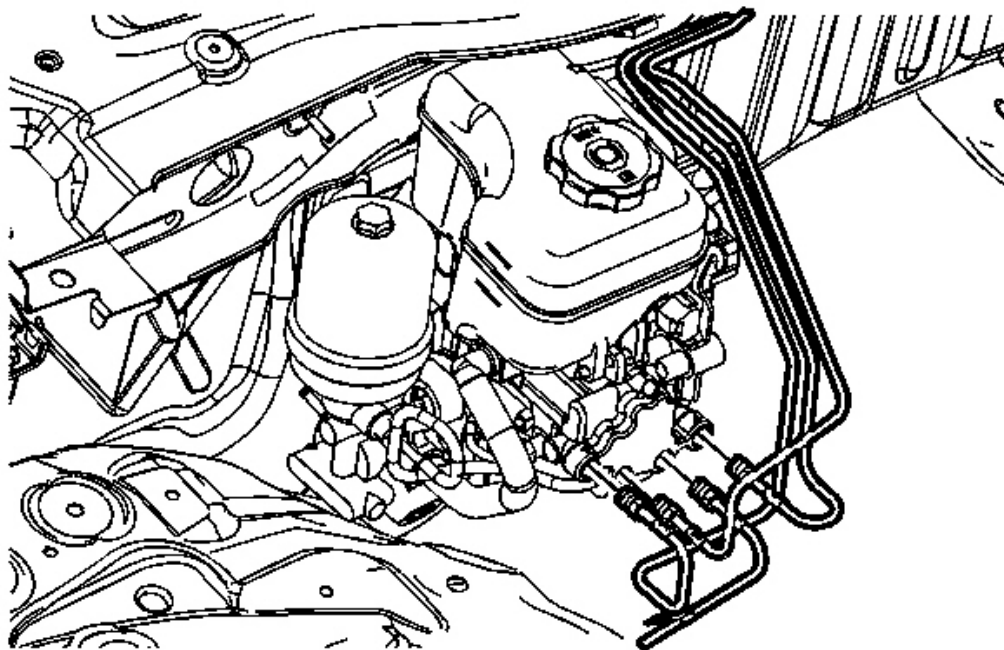

Fig. 39: View Of Brake Pipe Fittings & The Master Cylinder
Courtesy of GENERAL MOTORS CORP.

10. Connect the 4 brake pipe fittings to the master cylinder.

Tighten: Tighten the fittings to 19 N.m (14 lb ft).

11. Adjust the stop lamp switch. Refer to **Stop Lamp Switch Adjustment** .
12. Adjust the cruise release switch. Refer to **Cruise Release Switch Adjustment** .
13. Bleed the hydraulic brake system. Refer to **Hydraulic Brake System Bleeding (Manual)** or **Hydraulic Brake System Bleeding (Pressure)** .

BRAKE PRESSURE MODULATOR VALVE REPLACEMENT

Tools Required

CH-47830 Holding Fixture. See **Special Tools**.

Removal Procedure

CAUTION: Refer to Brake Fluid Irritant Caution .

1. Remove the brake master cylinder and power brake booster assembly. Refer to **Brake Master Cylinder with Power Brake Booster and Chassis Control Module Replacement (LHD)** or **Brake Master Cylinder with Power Brake Booster and Chassis Control Module Replacement (RHD)**.
2. Install the **CH-47830** to the master cylinder assembly. See **Special Tools**.
3. Position the **CH-47830** with the master cylinder assembly in a vise. See **Special Tools**.

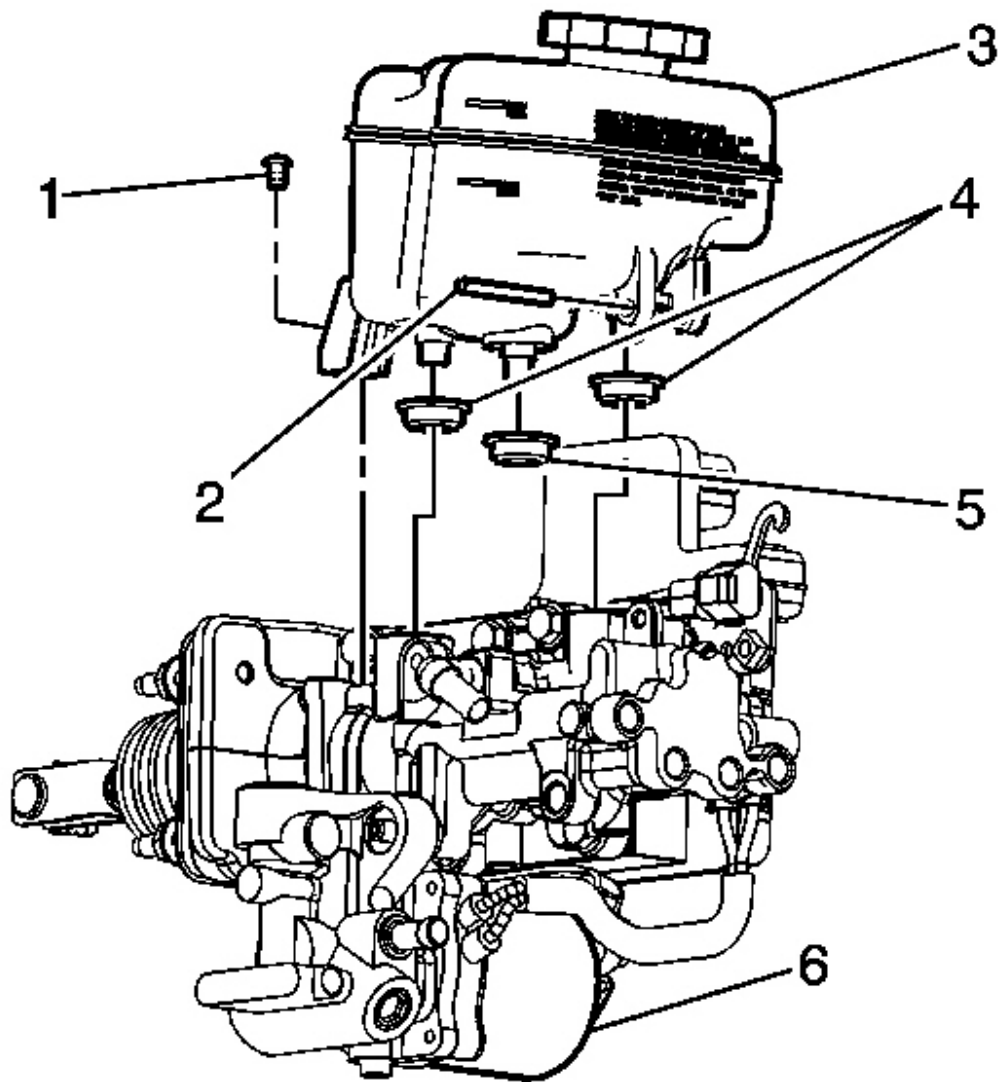

Fig. 40: Identifying Master Cylinder Reservoir
Courtesy of GENERAL MOTORS CORP.

4. Remove the master cylinder reservoir (3). Refer to **Master Cylinder Reservoir Replacement** .
5. Remove the power brake booster (6). Refer to **Power Brake Booster Replacement** .

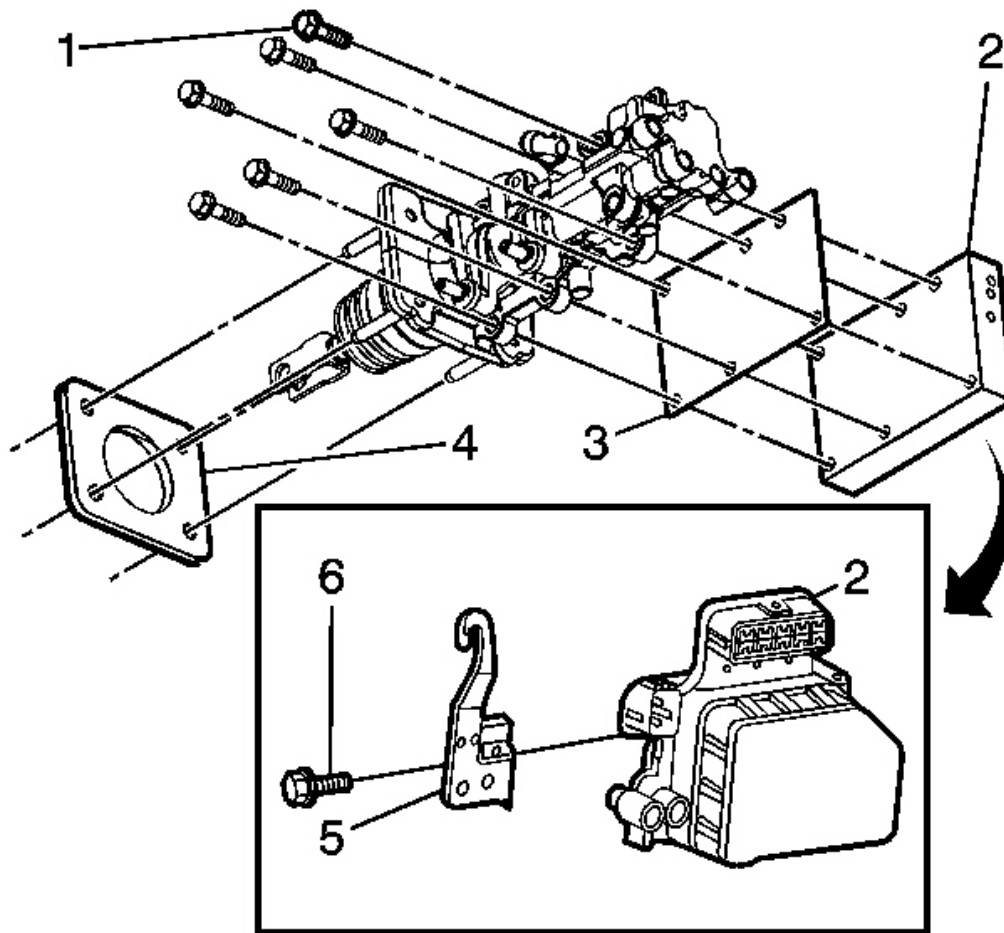

Fig. 41: View Of Brake Pressure Modulator Valve & Bolts
 Courtesy of GENERAL MOTORS CORP.

6. Remove the mounting bolts for the brake pressure modulator valve (BPMV) (1).
7. Remove the mounting bolt (6) for the fluid level sensor.
8. Remove the bracket (5) for the fluid level sensor wiring harness.

IMPORTANT: When removing the BPMV from the brake master cylinder, ensure the locating pin remains in the brake master cylinder body.

9. Remove the BPMV and module assembly (2) from the brake master cylinder.

IMPORTANT: DO NOT re-use the BPMV gasket.

10. Remove and discard the gasket (3) from the brake master cylinder.

Installation Procedure

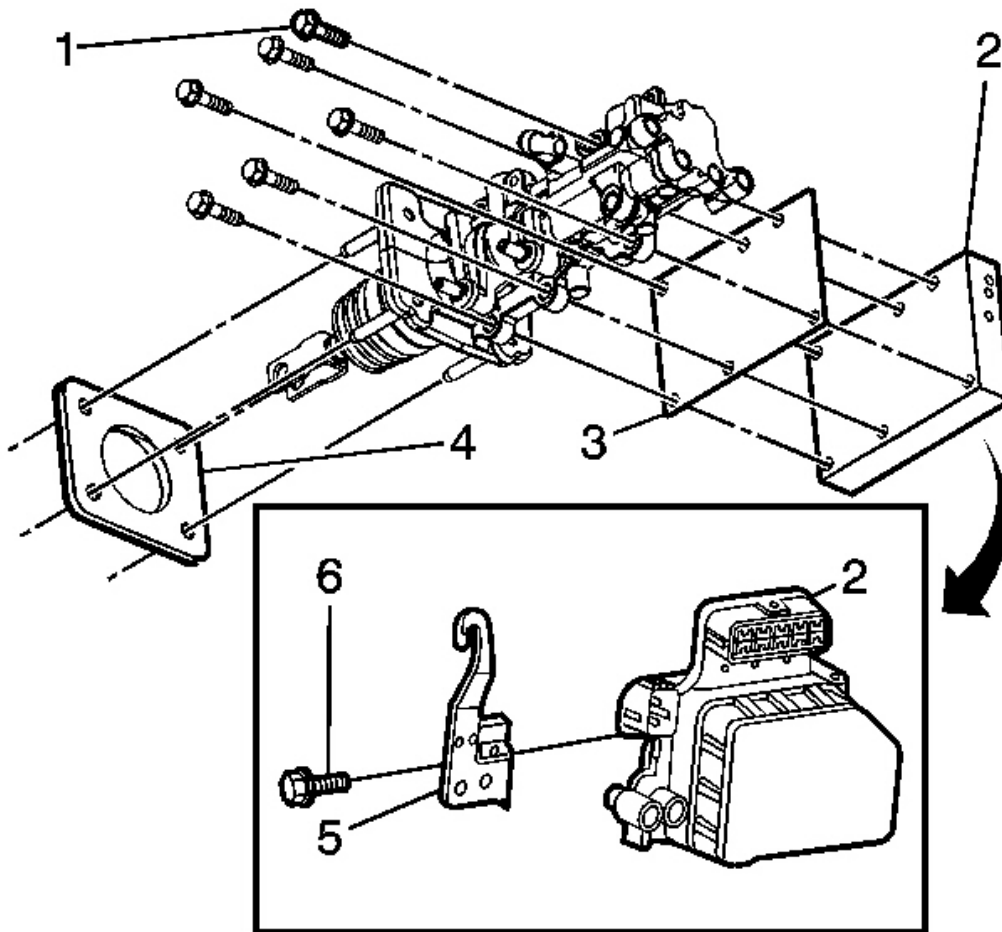

Fig. 42: View Of Brake Pressure Modulator Valve & Bolts
Courtesy of GENERAL MOTORS CORP.

1. Install a NEW BPMV and module assembly gasket (3) to the master cylinder.

IMPORTANT: Ensure the locating pins remain in the master cylinder body.

2. Install the BPMV and module assembly (2) to the brake master cylinder.

NOTE: Refer to Fastener Notice .

IMPORTANT: Hand install all of the BPMV and module assembly bolts to properly locate the BPMV and module assembly before tightening the bolts.

3. Install the bolts (1) for the BPMV and module assembly.

Tighten: Tighten the bolts to 32 N.m (24 lb ft).

4. Install the bracket (5) for the fluid level sensor electrical harness.
5. Install the mounting bracket bolt (6).

Tighten: Tighten the bolt to 8 N.m (71 lb in)

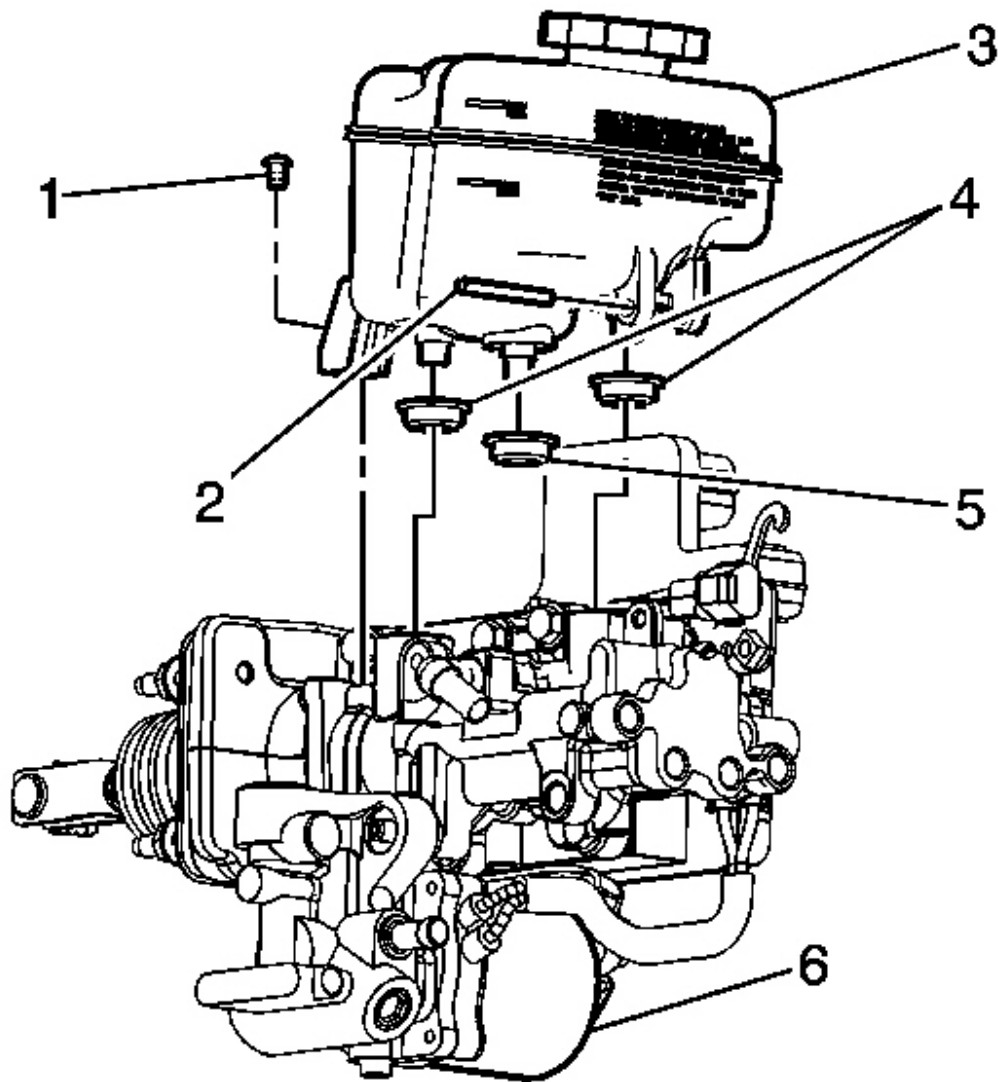

Fig. 43: Identifying Master Cylinder Reservoir
Courtesy of GENERAL MOTORS CORP.

6. Install the power brake booster (6). Refer to **Power Brake Booster Replacement** .
7. Install the master cylinder reservoir (3). Refer to **Master Cylinder Reservoir Replacement** .
8. Remove the brake master cylinder assembly from CH-47830 . See **Special Tools**.

9. Install the brake master cylinder and power brake booster assembly. Refer to **Brake Master Cylinder with Power Brake Booster and Chassis Control Module Replacement (LHD)** or **Brake Master Cylinder with Power Brake Booster and Chassis Control Module Replacement (RHD)**.
10. Bleed the hydraulic system. Refer to **Hydraulic Brake System Bleeding (Manual)** or **Hydraulic Brake System Bleeding (Pressure)**.
11. Refer to **Control Module References** for programming and setup information.

FRONT WHEEL SPEED SENSOR REPLACEMENT

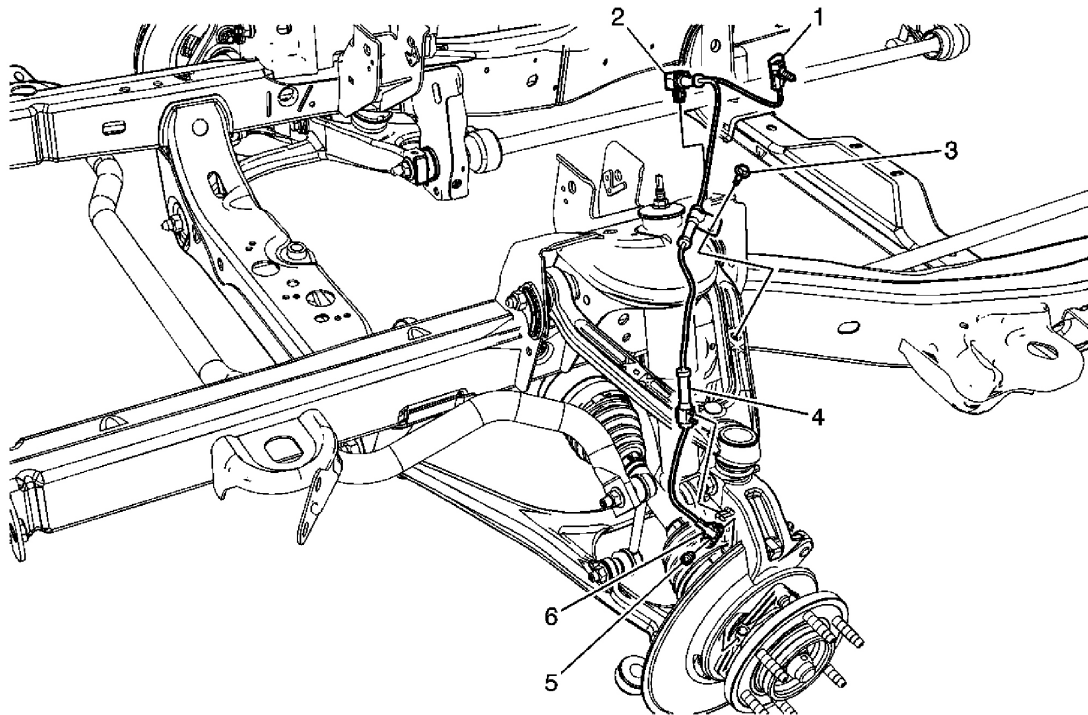

Fig. 44: Replacing Front Wheel Speed Sensor
 Courtesy of GENERAL MOTORS CORP.

Front Wheel Speed Sensor Replacement

Callout	Component Name
Preliminary Procedures	
<ol style="list-style-type: none"> 1. Raise and support the vehicle. Refer to <u>Lifting and Jacking the Vehicle</u>. 2. Remove the tire and wheel. Refer to <u>Tire and Wheel Removal and Installation</u>. 3. Remove the front disc brake rotor. Refer to <u>Front Brake Rotor Replacement</u>. 	

2007 Hummer H3

2007 BRAKES Antilock Brake System - H3

1	Wheel Speed Sensor Electrical Connector Procedure: Disconnect the electrical connector and release the clip from the vehicle body.
2	Wheel Speed Sensor Wiring Harness Retaining Clip
3	Wheel Speed Sensor Harness Clip Bolt (if equipped) NOTE: Refer to <u>Fastener Notice</u> . Tip: If equipped with a wheel speed sensor wire harness clip, release the clip from the upper control arm. Tighten: 9 N.m (80 lb in)
4	Wheel Speed Sensor Wiring Harness Retaining Clip
5	Wheel Speed Sensor Mounting Bolt Tighten: 18 N.m (13 lb ft)
6	Wheel Speed Sensor

REAR WHEEL SPEED SENSOR REPLACEMENT

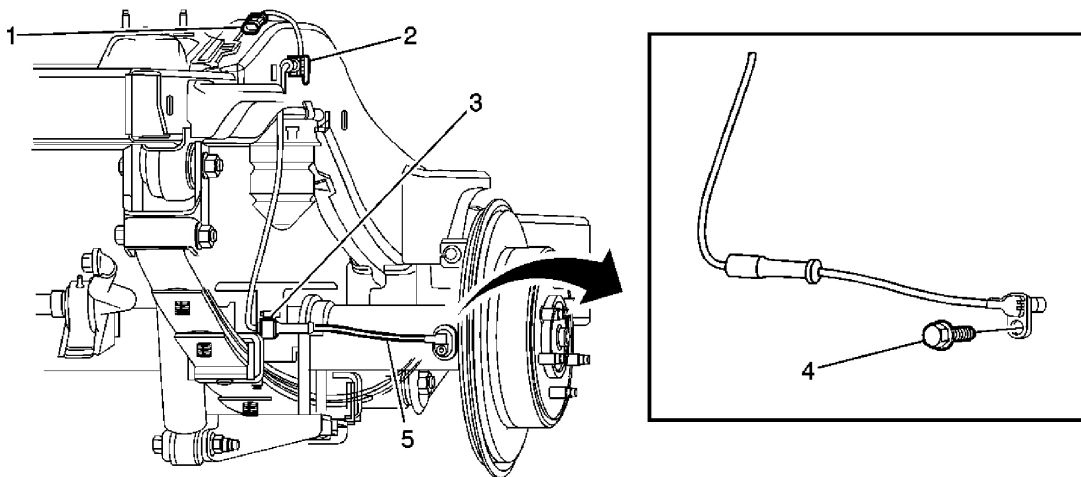

Fig. 45: Wheel Speed Sensor Replacement - Rear
Courtesy of GENERAL MOTORS CORP.

Rear Wheel Speed Sensor Replacement

2007 Hummer H3

2007 BRAKES Antilock Brake System - H3

Callout	Component Name
NOTE: Refer to <u>Fastener Notice</u> .	
Fastener Tightening Specifications: Refer to <u>Fastener Tightening Specifications</u> . Preliminary Procedure: Raise the vehicle. Refer to <u>Lifting and Jacking the Vehicle</u> .	
1	Connector, ABS Electrical
2	Clip, ABS Wiring Harness Frame Retaining
3	Clip, ABS Wiring Harness Axle Housing Retaining
4	Bolt, Wheel Speed Sensor Mounting (Qty: 2) Tighten: 18 N.m (13 lb ft)
5	Sensor, Wheel Speed

REAR WHEEL SPEED SENSOR RING REPLACEMENT

Tools Required

- **J 8092** Driver Handle
- **J 21128** Axle Pinion Oil Seal Installer
- **J 23690** Bearing Installer
- **J 2619-01** Slide Hammer
- **J 45857** Tone Wheel and/or Bearing Remover
- **J 45860** Tone Ring Installer

Removal Procedure

1. Raise the vehicle. Refer to Lifting and Jacking the Vehicle .
2. Remove the tire and wheel assembly. Refer to Tire and Wheel Removal and Installation .
3. Remove the rear wheel speed sensor. Refer to Rear Wheel Speed Sensor Replacement.
4. Remove the rear axle housing cover. Refer to Rear Axle Housing Cover and Gasket Replacement .
5. Remove the axle shaft. Refer to Rear Axle Shaft Replacement .

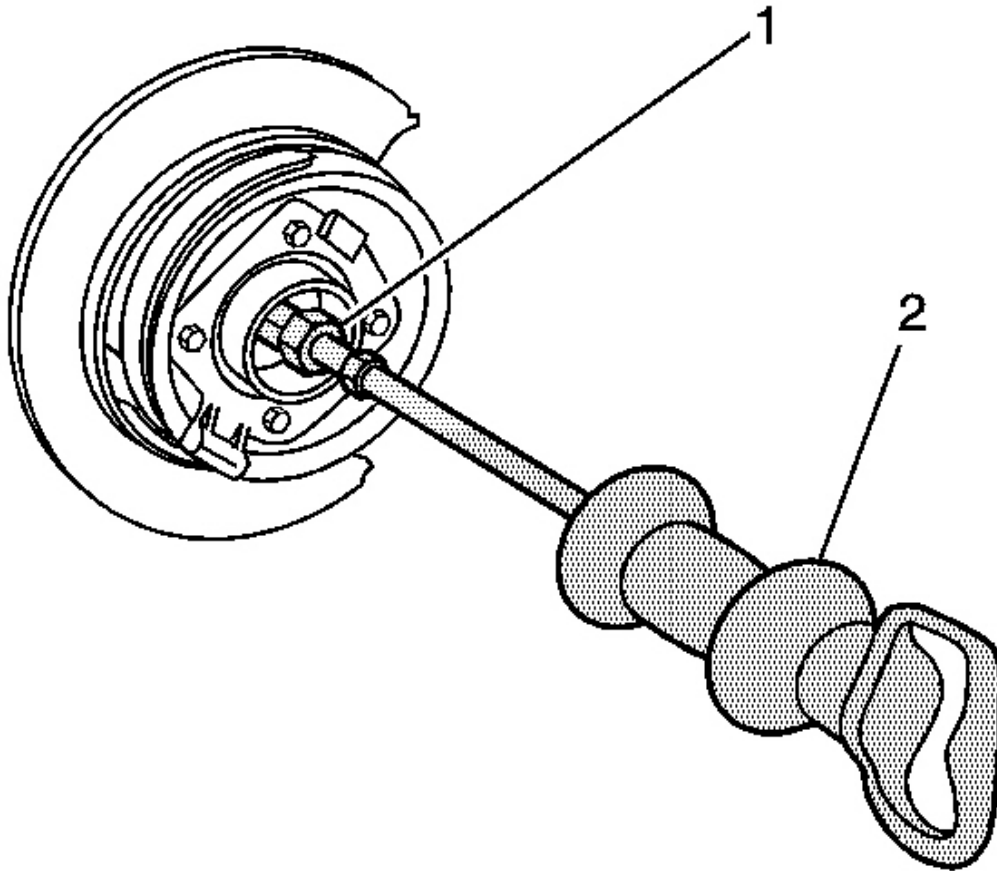

Fig. 46: The Wheel Speed Sensor Ring From The Axle Housing
Courtesy of GENERAL MOTORS CORP.

6. Remove the axle shaft seal, the bearing and the wheel speed sensor ring from the axle housing using the **J 45857** (1) and the **J 2619-01** (2).

Installation Procedure

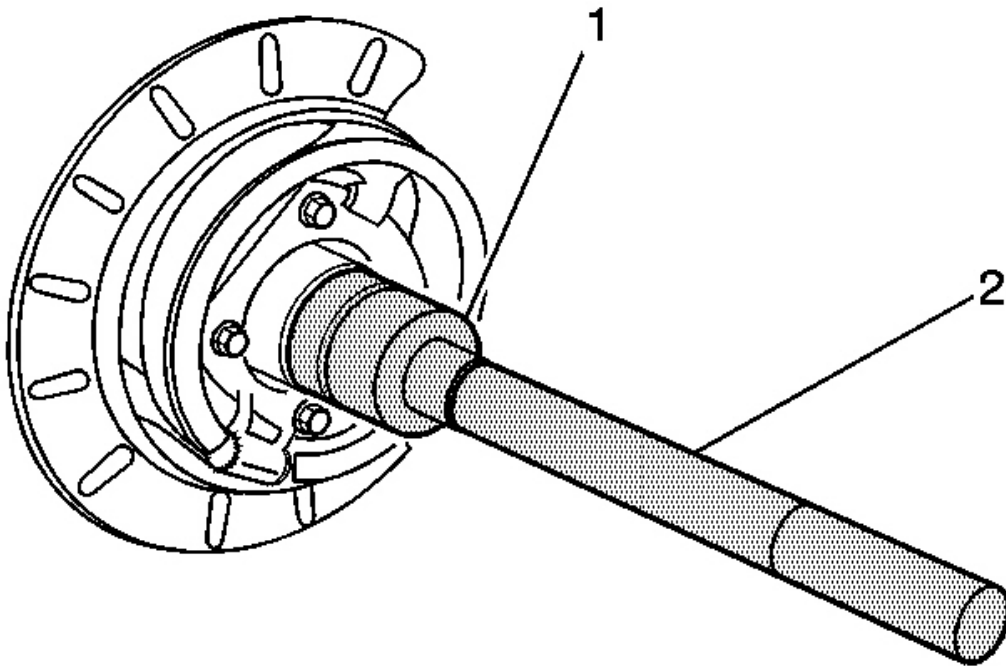

Fig. 47: Installing Wheel Speed Sensor Ring
Courtesy of GENERAL MOTORS CORP.

1. Install the wheel speed sensor ring using the **J 45860** (1) and the **J 8092** (2).
2. Drive the wheel speed sensor ring into the axle housing until the tool bottoms against the tube.

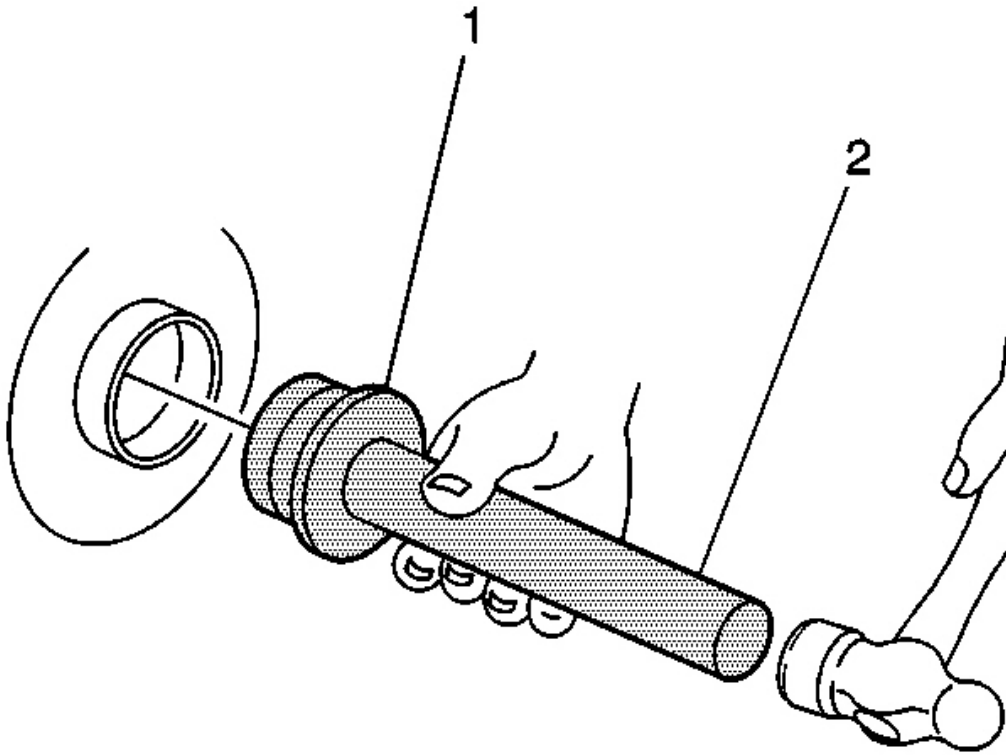

Fig. 48: Installing The Axle Shaft Bearing
Courtesy of GENERAL MOTORS CORP.

3. Install the axle shaft bearing using the **J 23690** (1) and the **J 8092** (2).
4. Drive the axle shaft bearing into the axle housing until the tool bottoms against the tube.

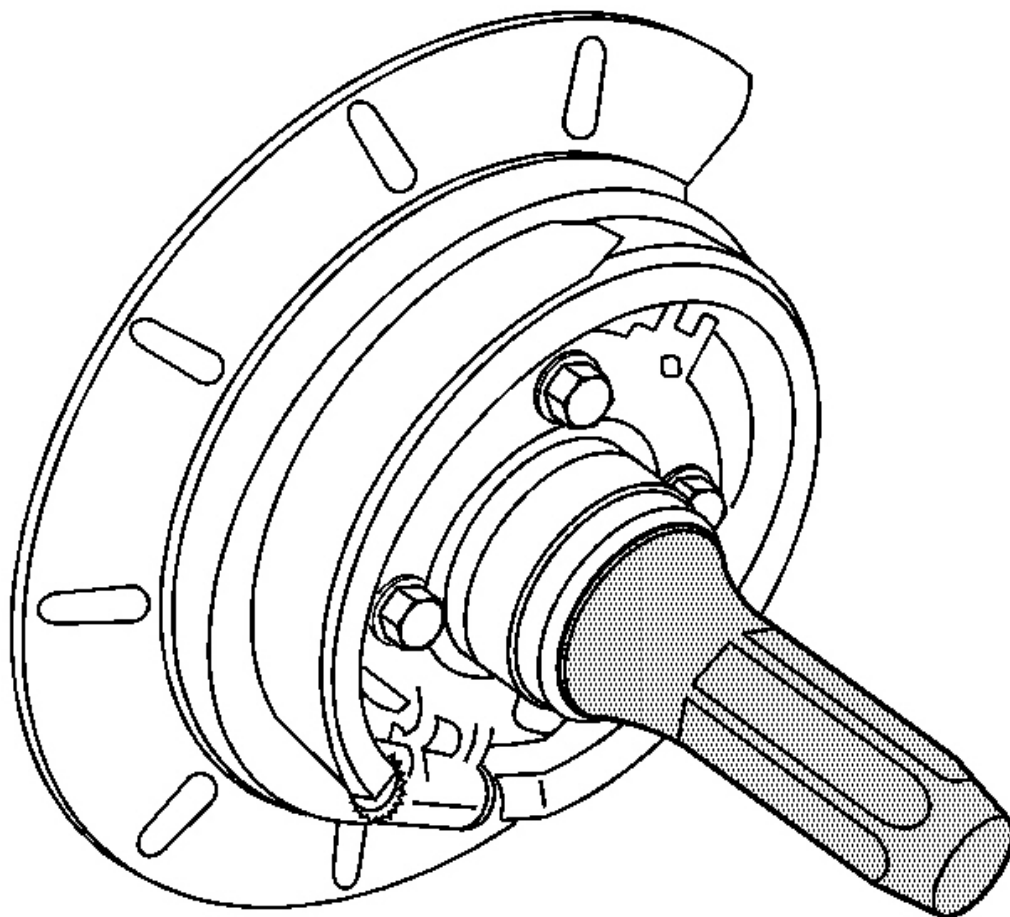

Fig. 49: Installing Axle Shaft Seal
Courtesy of GENERAL MOTORS CORP.

5. Install the axle shaft seal using the **J 21128** .
6. Drive the tool into the bore until the axle shaft seal bottoms flush with the tube.
7. Install the axle shaft. Refer to **Rear Axle Shaft Replacement** .
8. Install the rear axle housing cover. Refer to **Rear Axle Housing Cover and Gasket Replacement** .
9. Install the rear wheel speed sensor. Refer to **Rear Wheel Speed Sensor Replacement**.
10. Install the tire and wheel assembly. Refer to **Tire and Wheel Removal and Installation** .
11. Fill the rear axle. Refer to **Rear Axle Lubricant Replacement** .

12. Lower the vehicle.

**VEHICLE YAW SENSOR WITH VEHICLE LATERAL AND LONGITUDINAL ACCEL
ACCELEROMETER REPLACEMENT**

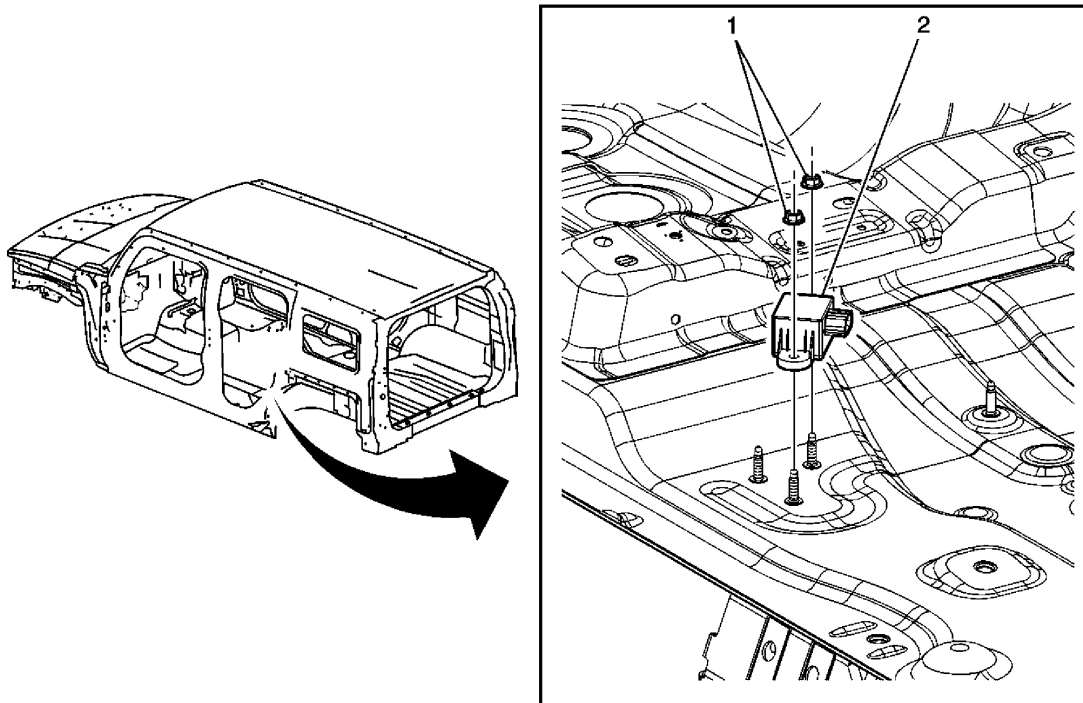

Fig. 50: Yaw Rate Sensor/Lateral and Longitudinal Accelerometer Replacement
Courtesy of GENERAL MOTORS CORP.

Vehicle Yaw Sensor with Vehicle Lateral and Longitudinal Accelerometer Replacement

Callout	Component Name
<p>NOTE: Refer to <u>Fastener Notice</u> .</p>	
<p>Fastener Tightening Specifications: Refer to <u>Fastener Tightening Specifications</u>. Preliminary Procedure: Remove the front carpet enough to access the yaw rate sensor. Refer to <u>Front Floor Panel Carpet Replacement</u> .</p>	
1	<p>Nut, Longitudinal Accelerometer (Qty: 2) Tighten: 9 N.m (80 lb in)</p>
2	<p>Sensor, Longitudinal Accelerometer Tip: Remove the electrical connector.</p>

DESCRIPTION AND OPERATION

ABS DESCRIPTION AND OPERATION

This vehicle is equipped with an Advics HB-CI brake master cylinder assembly. The electronic brake control module (EBCM) and the brake pressure modulator valve (BPMV) is serviced as one assembly. The BPMV uses a 4 circuit configuration to control hydraulic pressure to each wheel independently.

The following vehicle performance enhancement systems are provided.

- Antilock Brake System (ABS)
- Dynamic Rear Proportioning (DRP)
- Hydraulic Brake Booster Power Supply
- Traction Control System (TCS) (w/NW7)
- Vehicle Stability Enhancement System (VSES) (w/JL4)

The following components are involved in the operation of the above systems:

- **ABS Pump Motor** - The ABS pump motor is part of the hydraulic brake booster. The ABS pump motor is active during ABS, VSES and base brake power assist functions.
- **Accumulator Pressure Sensor**-The accumulator pressure sensor is located internally within the BPMV. The accumulator pressure sensor uses a 5-volt reference and generates an output signal proportionate to the hydraulic fluid pressure which is present in the accumulator.
- **Backup Lamp Switch**- On vehicles equipped with manual transmissions, the EBCM receives a voltage signal on the backup lamp supply voltage circuit when the vehicle is in reverse gear. The EBCM uses the backup lamp supply voltage circuit to enhance the operation of the ABS, VSES and TCS in reverse.
- **Yaw Rate Sensor/Lateral and Longitudinal Accelerometer (w/JL4)**-The EBCM uses the lateral and longitudinal accelerometers to determine the sideways and front to back acceleration of the vehicle. The Yaw rate sensor determines the vehicle rotation. The lateral accelerometer, yaw rate and longitudinal sensor are combined into one single component.
- **Longitudinal Accelerometer (w/o JL4)**-The EBCM uses the longitudinal accelerometer to determine the actual straight-line acceleration of the vehicle.
- **Master Cylinder Pressure Sensor**-The master cylinder pressure sensor is located within the BPMV. The master cylinder pressure sensor uses a 5-volt reference and generates an output signal proportionate to the hydraulic fluid pressure which is present in the hydraulic brake circuit at the master cylinder.

- Solenoids-The solenoids are commanded ON and OFF by the EBCM to operate the appropriate valves in the BPMV.
- Steering Wheel Position Sensor (SWPS) (w/JL4)-The EBCM uses the SWPS as an indication of the position and rotation of the steering wheel.
- System relays-There are two system relays internal to the EBCM. The solenoid relay is energized when the ignition is ON. The ABS pump motor relay supplies battery positive voltage to the ABS pump motor when the EBCM commands the ABS pump motor on. The system relays are non serviceable.
- Traction Control Switch - Engine traction Control and VSES is manually disabled or enabled using the traction control switch.
- Wheel Speed Sensors (WSS)-EBCM sends a 12-volt reference voltage signal to each wheel speed sensor. As the wheel spins, the wheel speed sensor produces a square wave DC signal voltage. The wheel speed sensor increases the signal frequency as the wheel speed increases, but does not increase the signal amplitude.
- Stop Lamp Switch-The EBCM receives a voltage signal on the stop lamp supply voltage circuit when the brake pedal is applied. The EBCM applies a voltage to the center high mounted stop lamp (CHMSL) during a VSES event and sends a serial data message to the body control module (BCM) requesting stop lamp activation. The EBCM uses the stop lamp supply voltage circuit to enhance the operation of the ABS, VSES and TCS.

Antilock Brake System (ABS) Operation

When wheel slip is detected during a brake application, an ABS event occurs. During antilock braking, hydraulic pressure in the individual wheel circuits is controlled to prevent any wheel from slipping. A separate hydraulic line and specific solenoid valves are provided for each wheel. The ABS can decrease, hold or increase hydraulic pressure to each wheel. The ABS does not, however, increase hydraulic pressure above the amount which is transmitted by the master cylinder during braking.

During antilock braking, a series of rapid pulsations is felt in the brake pedal. These pulsations are caused by the rapid changes in position of the individual solenoid valves as the electronic brake control module (EBCM) responds to wheel speed sensor inputs and attempts to prevent wheel slip. These pedal pulsations are present only during antilock braking and stop when normal braking is resumed or when the vehicle comes to a stop. A ticking or popping noise may also be heard as the solenoid valves cycle rapidly. During antilock braking on dry pavement, intermittent chirping noises may be heard as the tires approach slipping. These noises and pedal pulsations are considered normal during antilock operation.

Vehicles equipped with ABS may be stopped by applying normal force to the brake pedal. Brake

2007 Hummer H3

2007 BRAKES Antilock Brake System - H3

pedal operation during normal braking is no different than that of previous non-ABS systems. Maintaining a constant force on the brake pedal provides the shortest stopping distance while maintaining vehicle stability. The typical ABS activation sequence is as follows:

Pressure Hold

The EBCM closes the isolation valve and keeps the dump valve closed in order to isolate the slipping wheel when wheel slip occurs. This holds the pressure steady on the brake so that the hydraulic pressure does not increase or decrease.

Pressure Decrease

If a pressure hold does not correct the wheel slip condition, a pressure decrease occurs. The isolation valve remains closed and the dump valve is opened. This allows a small amount of brake fluid to escape from the hydraulic circuit into the reservoir.

Pressure Increase

After the wheel slip is corrected, a pressure increase occurs. The isolation and dump valves are returned to their off states and brake pressure in the hydraulic circuit is once again dependent on the amount of force applied to the brake pedal by the driver. If the driver applies too much pressure causing wheel slip, the ABS activation sequence reoccurs.

Dynamic Rear Proportioning (DRP) Operation

The dynamic rear proportioning (DRP) is a control system that enhances the hydraulic proportioning function of the mechanical proportioning valve in the base brake system. The DRP control system is part of the operation software in the electronic brake control module (EBCM). The DRP uses active control with existing ABS in order to regulate the vehicle's rear brake pressure.

Traction Control System (TCS)

When drive wheel slip is noted while the brake is not applied, the electronic brake control module (EBCM) will enter traction control mode.

The EBCM sends pulse width modulated (PWM) signal to the powertrain control module (PCM) to reduce the amount of torque to the drive wheels. The PCM reduces torque to the drive wheels by retarding spark timing and by commanding the throttle actuator control. The PCM uses a 12-volt PWM signal in order to report to the EBCM the amount of torque delivered to the drive wheels.

If the engine torque reduction does not eliminate drive wheel slip, the EBCM will actively apply

the drive wheel brakes. During traction control braking, hydraulic pressure in each drive wheel circuit is controlled to prevent the drive wheels from slipping.

Vehicle Stability Enhancement System (VSES)

The vehicle stability enhancement system (VSES) adds an additional level of vehicle control to the electronic brake control module (EBCM).

Yaw rate is the rate of rotation about the vehicle's vertical axis. The lateral accelerometer measures the sideways acceleration of the vehicle. The VSES is activated when the EBCM determines that the desired yaw rate and lateral forces do not match the actual attitude of the vehicle.

The desired attitude of the vehicle are calculated from the following inputs:

- The position of the steering wheel
- The speed of the vehicle
- The lateral or sideways acceleration of the vehicle
- Yaw Rate of the vehicle
- Master cylinder brake pressure

The difference between the desired yaw rate and the actual yaw rate is the yaw rate error, which is a measurement of oversteer or understeer. If the yaw rate error becomes too large, the EBCM attempts to correct the vehicles yaw motion by applying differential braking to the appropriate wheel. The amount of differential braking applied to the wheels is based on both the yaw rate error and side slip rate error.

The VSES activations generally occur during aggressive driving, in turns or on poor road conditions without much use of the accelerator pedal. When braking during VSES activation, the pedal pulsations feel different than the ABS pedal pulsations. The brake pedal pulsates at a higher frequency during VSES activation.

Power-up Self-Test

The electronic brake control module (EBCM) is able to detect many malfunctions whenever the ignition is ON. However, certain failures cannot be detected unless active diagnostic tests are performed on the components. Shorted solenoid coil or motor windings, for example, cannot be detected until the components are commanded ON by the EBCM. Therefore, a power-up self-test is required at the beginning of each ignition cycle to verify correct operation of components before the various control systems can be enabled. The EBCM performs the power-up self-test when the vehicle achieves a speed greater than 6 km/h (4 mph). The solenoid relay is commanded

ON and OFF to verify proper operation and the EBCM verifies the ability to return the system to base braking in the event of a failure. The power-up self-test may sometimes be heard by the driver or passengers of the vehicle.

ECE 13 Response

The ABS indicator illuminates when a malfunction which disables ABS is detected. Often, the ABS indicator turns OFF following the instrument panel cluster (IPC) bulb check during the next ignition cycle unless the fault is detected during that ignition cycle. However, the setting of certain DTCs may cause the ABS indicator to remain illuminated during the subsequent ignition cycle until the vehicle is operated at a speed greater than 10 km/h (7 mph) and no fault is detected. This is referred to as an ECE 13 response. It is important to verify that ECE 13 is not the cause of an ABS indicator which is illuminated when no DTCs are set, before attempting to diagnose other possible causes.

Driver Information Indicators and Messages

The following indicators are used to inform the driver of several different conditions:

Brake Warning Indicator

The instrument panel cluster (IPC) illuminates the brake warning indicator when any of the following instances occur.

- Body control module (BCM) detects that the park brake is engaged. The BCM sends a serial data message to the IPC requesting illumination.
- EBCM detects a low brake fluid condition. The EBCM sends a serial data message to the IPC requesting illumination.
- IPC performs the bulb check.
- IPC detects a loss of serial data communication with the EBCM.
- EBCM detects an ABS-disabling malfunction which also disables dynamic rear proportioning (DRP). The EBCM sends a serial data message to the IPC requesting illumination.
- EBCM detects the loss of the brake assist function.

ABS Indicator

The IPC illuminates the ABS indicator when any of the following instances occur.

- The EBCM detects an ABS-disabling malfunction. The EBCM sends a serial data message to the IPC requesting illumination.

- The IPC performs the bulb check.
- The IPC detects a loss of serial data communication with the EBCM.
- An ECE 13 response occurs at the beginning of an ignition cycle. The EBCM sends a serial data message to the IPC requesting illumination.

Stability Caution Indicator

The stability caution indicator flashes when the VSES is active and illuminates solid when there is a TCS or VSES fault.

ABS Fault Message

The IPC displays the message whenever the ABS indicator is illuminated due to an ABS fault.

BRAKE SYSTEM Fault Message

The IPC displays the message whenever the red brake warning indicator is illuminated due to a base brake or DRP fault.

BRAKE FLUID Fault Message

The IPC displays the message when the EBCM sets a C0267 for low brake fluid level.

SERVICE STAB SYS fault Message

The IPC displays the traction fault message when either of the following instances occur:

- The EBCM detects a malfunction that requires VSES to be disabled. The EBCM sends a serial data message to the IPC requesting that the message be displayed.
- The IPC detects a loss of serial data communication with the EBCM.

SERVICE TRACTION fault Message

The IPC displays the traction fault message when either of the following instances occur:

- The EBCM detects a malfunction that requires traction control to be disabled. The EBCM sends a serial data message to the IPC requesting that the message be displayed.
- The IPC detects a loss of serial data communication with the EBCM.

SPECIAL TOOLS AND EQUIPMENT**SPECIAL TOOLS**

2007 Hummer H3

2007 BRAKES Antilock Brake System - H3

Special Tools

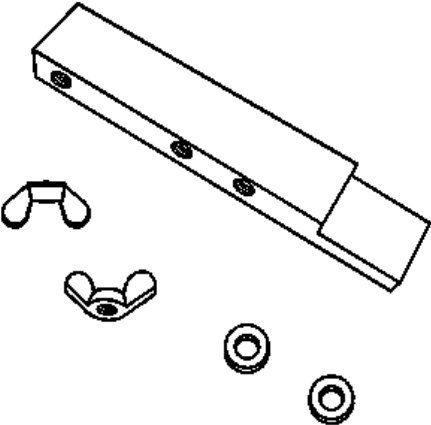
Illustration	Tool Number/Description
 The illustration shows a long, rectangular metal holding fixture with a tapered end. It has three circular holes along its length. Below the fixture are two U-shaped clips, one larger than the other, and two circular washers or spacers.	<p>CH 47830 Holding Fixture</p>