

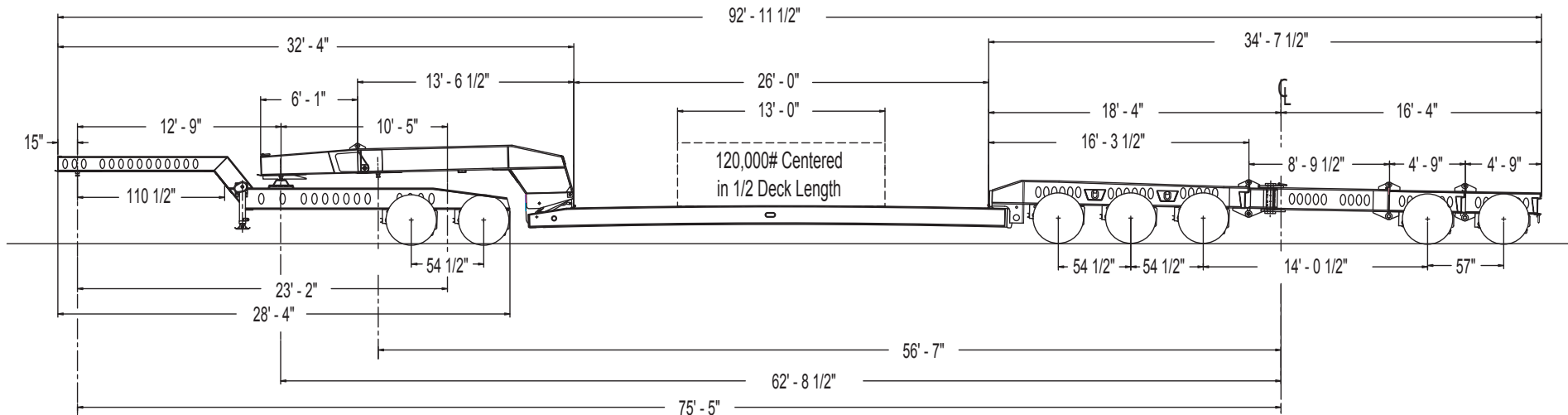

# 60 TON SPECIALIZED SERIES

## "3 + 2" WITH STINGER & JEEP DOLLY



- Trailer can be configured as a fixed 3 axle, 4 axle, 5 axle, 3 + 1 spread, or 3 + 2 spread.
- Shim blocks for the gooseneck, detachable rear frame, and each removable axle allow for deck height and axle load adjustments.
- All longitudinal beams constructed with 100,000 psi minimum yield flange steel.
- 25,000 lbs capacity air ride suspension each axle.
- 275/80R22.5 (H) tires on hub piloted steel disc wheels.

- Low-pressure hydraulic system operates gooseneck at approximately 2000 psi from either 16 HP Kohler pony motor or tractor PTO.
- US-DOT approved 12 volt, rubber-mounted, sealed beam lights with weather resistant modular wiring system.
- Corrosion resistant undercoating on trailer subframe.
- Standard Finish - RBC Red.
- Seven year limited structural warranty.



**ROGERS BROTHERS CORPORATION**  
 100 Orchard Street Albion, Pennsylvania 16401  
 Phone (814) 756-4121 Fax (814) 756-4830  
 Toll Free (800) 441-9880  
 www.rogerstrailers.com