

Magstar and IBM 3590 High Performance Tape Subsystem Technical Guide

November 1996

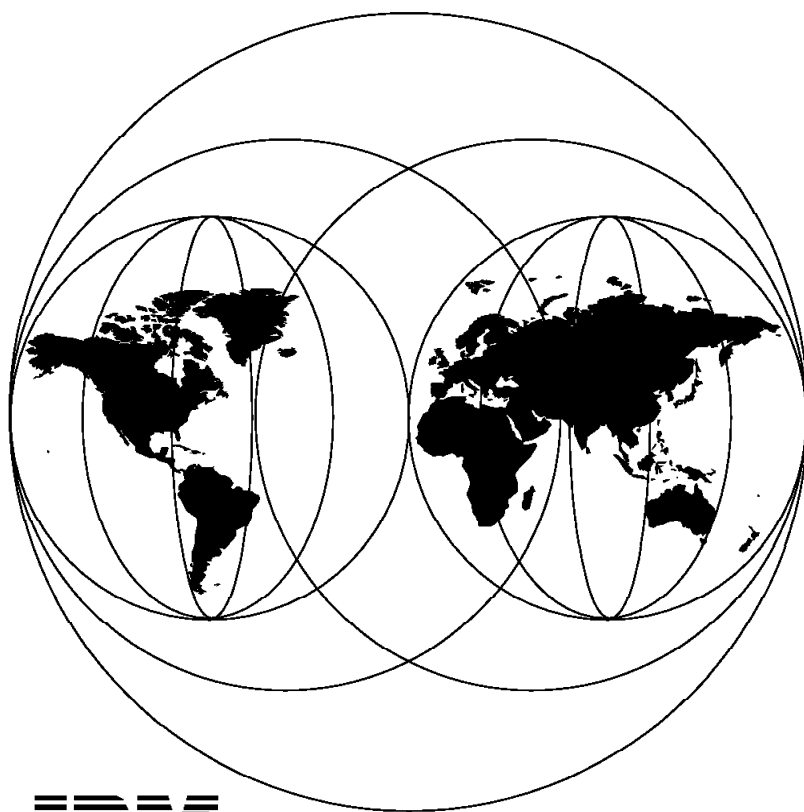

IBM

**International Technical Support Organization
San Jose Center**



International Technical Support Organization

SG24-2506-01

**Magstar and IBM 3590 High Performance Tape Subsystem
Technical Guide**

November 1996

Take Note!

Before using this information and the product it supports, be sure to read the general information in Appendix B, "Special Notices" on page 243.

Second Edition (November 1996)

This edition applies to the IBM 3590 High Performance Tape Subsystem, IBM Magstar Virtual Tape Server, IBM 3591-A01, IBM 3590-C12, and IBM 3494 enhancements.

Comments may be addressed to:
IBM Corporation, International Technical Support Organization
Dept. 471 Building 80-E2
650 Harry Road
San Jose, California 95120-6099

When you send information to IBM, you grant IBM a non-exclusive right to use or distribute the information in any way it believes appropriate without incurring any obligation to you.

© **Copyright International Business Machines Corporation 1996. All rights reserved.**

Note to U.S. Government Users — Documentation related to restricted rights — Use, duplication or disclosure is subject to restrictions set forth in GSA ADP Schedule Contract with IBM Corp.

Contents

Figures	ix
Tables	xi
Preface	xiii
How This Redbook Is Organized	xiii
The Team That Wrote This Redbook	xv
Comments Welcome	xvi
Chapter 1. Introduction to the New Technology	1
1.1 Tape Technology History	2
1.2 Half-Inch Cartridge Tape History	5
1.3 IBM 3590 Magstar Products	6
1.4 Design Targets and Market Requirements	9
1.5 New Technology	11
1.5.1 Objectives	11
1.5.2 Options	12
1.6 Metal Particle Medium	13
1.7 Interleaved Longitudinal Recording	14
1.8 Serpentine Interleaved Track Sets	15
1.9 Why Use Longitudinal Technology?	17
1.10 IBM Tape Products	18
1.11 IBM 3590 Tape Space Utilization	20
1.12 Now Announced the IBM Magstar Virtual Tape Server	21
1.12.1 Virtual Tape Server for IBM 3494 Tape Library	21
1.12.2 Virtual Tape Server for IBM 3495 Tape Library	22
Chapter 2. IBM 3590 High Performance Tape Subsystem Hardware	
Description	23
2.1 Magstar Tape Drive	24
2.2 Magstar Tape Drive Schematic Comparison	27
2.3 IBM 3590 Drive Models	28
2.4 IBM 3590 Control Unit	30
2.5 IBM 3590 Frame	32
2.6 IBM 3590 Environmentals	34
2.7 IBM 3590 High Performance Tape Cartridge	36
Chapter 3. IBM 3590 Automatic Cartridge Facility Operations	39
3.1 Automatic Cartridge Facility	40
3.1.1 Operator Panel	40
3.1.2 Priority Cell	40
3.1.3 Ten-slot Magazine	41
3.1.4 Status Lights	41
3.1.5 Transport Mechanism	41
3.2 IBM 3590 Operator Panel	42
3.3 IBM 3590 Operator Panel Screens	44
3.4 ACF Magazine	46
3.4.1 Export Position	46
3.4.2 Import Position	46
3.4.3 Magazine Locking	47
3.5 ACF Modes of Operation	48

3.6 ACF Manual Mode	51
3.6.1 Operational Flow	51
3.6.2 Disabling Conditions	52
3.7 ACF Accumulate Mode	53
3.7.1 Operational Flow	53
3.7.2 Disabling Conditions	54
3.8 ACF Automatic Mode	55
3.8.1 Operational Flow	56
3.8.2 Disabling Conditions	56
3.9 ACF System Mode	57
3.9.1 Operational Flow	58
3.9.2 Disabling Conditions	58
3.10 ACF Random Mode	59
3.10.1 Operational Flow	60
3.10.2 Disabling Conditions	61
3.11 ACF Mode Enabling and Disabling	62
Chapter 4. Configuration Guidance	65
4.1 IBM ES/9000 and S/390 Configurations	66
4.1.1 Host Attachment	66
4.1.2 ESCON Considerations	67
4.1.3 Library Manager Attachments	68
4.2 IBM 3495 Configurations	69
4.3 IBM 3495 Mixed Configurations	71
4.4 IBM AS/400 Configurations	73
4.4.1 Host Attachment	73
4.4.2 SCSI Considerations	74
4.4.3 Library Manager Attachments	74
4.4.4 Special Features	74
4.5 IBM RISC/6000 Configurations	75
4.5.1 Host Attachment	75
4.5.2 SCSI Considerations	76
4.5.3 Library Manager Attachments	76
4.5.4 Special Features	76
4.5.5 POWERparallel SP2	77
4.5.6 Sun Systems	77
4.6 IBM 3494 Configurations	78
4.6.1 IBM 3494 Model L10 (Parallel, ESCON, and SCSI)	79
4.6.2 IBM 3494 Model L12 (SCSI Only)	79
4.6.3 IBM 3494 Model L14 (ESCON Only)	79
4.6.4 IBM 3494 Model B16 (Virtual Tape Server subsystem)	80
4.6.5 Mixed Configurations	80
4.6.6 Library Sharing between Different Hosts	81
4.7 IBM 3494 Model Summary	82
4.7.1 Control Unit Frame Models	82
4.7.2 Drive Unit Frame Models	83
4.7.3 Storage Unit Frame Models	83
4.7.4 VTS Unit Frame Models.	83
4.7.5 IBM 3494-L10 Features	83
4.7.6 Installation Features and Upgrades	83
4.8 IBM 3494 Capacity Guidelines	85
4.9 IBM 3590 Feature Codes	86
4.9.1 Description of No-Charge Features	87
4.9.2 MES Field-Installation Features	88
4.9.3 New Features	88

4.10 IBM 3590 Subsystem Host Interfaces	90
Chapter 5. Software Support for the IBM 3590 High Performance Tape Subsystem	93
5.1 IBM 3590 Software Support Overview	94
5.1.1 ES/9000 and S/390 Parallel Server Environment	94
5.1.2 AS/400 Environment	95
5.1.3 RISC System/6000 and POWERparallel SP2 Environment	95
5.1.4 Sun Environment	95
5.2 New and Changed Read Channel Commands for ES/9000 and S/390 Systems	96
5.2.1 Separate Channel Commands for IPL Read and Normal Read	96
5.2.2 Read Previous to Replace Read Backward	97
5.2.3 New Read Media Characteristics	97
5.2.4 Changed Read Commands	97
5.3 New STAGE Channel Command for ES/9000 and S/390 Systems	98
5.4 Logical Block Numbers	100
5.5 IBM 3590 Support for MVS/ESA	101
5.5.1 Hardware Configuration Definition	101
5.5.2 Stand-Alone Dump Program	101
5.5.3 New Generic Unit Name	102
5.5.4 Device Support	102
5.6 IBM 3590 Support for DFSMS/MVS	104
5.6.1 Toleration PTFs	104
5.6.2 Supports Both Stand-Alone and Library Environment	104
5.6.3 Error Recovery Procedure for IBM 3590 Tape Drive	105
5.6.4 Sequential Access Method	105
5.6.5 Checkpoint/Restart	106
5.6.6 Open/Close/End-of-Volume	106
5.6.7 System-Managed Storage	107
5.6.8 Access Method Services Command Changes	108
5.6.9 Interactive Storage Management Facility	109
5.6.10 Hierarchical Storage Manager (DFSMSHsm)	110
5.6.11 Removable Media Manager (DFSMSrmm)	110
5.6.12 Object Access Method	112
5.6.13 Tape Library Support	113
5.7 IBM 3590 Support for JES3	117
5.7.1 Library Device Group Name	117
5.7.2 DTYPE for JUNIT	117
5.7.3 JES3 Dump Job Dynamic Support Program	118
5.7.4 Other JES3 Tape Dynamic Support Program	118
5.8 VM/ESA Version 2	119
5.8.1 CP	119
5.8.2 CMS	120
5.8.3 DFSMS/VM Removable Media Services	120
5.9 VSE/ESA Version 2	121
5.10 Transaction Processing Facility (TPF)	121
5.11 OS/400 Version 3 Release 1	122
5.12 AIX/6000 Version 3.2.5 and Version 4.1.1	123
5.13 SunOS and Solaris	125
5.14 ADSM for AIX/6000 and SunOS/Solaris	127
5.15 Other Software Supported for IBM 3590	128
Chapter 6. Tape Performance Considerations	131
6.1 IBM 3490E ESCON Data Rate	132

6.1.1	Native Data Rates	132
6.1.2	Data Compression	133
6.1.3	Effective Data Rates	133
6.2	IBM 3490E ESCON Data Rate Chart	135
6.3	IBM 3490E SCSI Data Rate	137
6.4	IBM 3490E SCSI Data Rate Chart	138
6.5	IBM 3590 ESCON Data Rate	139
6.6	IBM 3590 SCSI Data Rate	140
6.7	IBM 3590 SCSI Data Rate Chart	141
6.8	IBM AS/400 Data Rate Chart	142
6.9	Autoblocking and Compression	143
6.9.1	Cartridge Capacity	143
6.9.2	Compression Improvements	144
6.9.3	Moving to the New Cartridges	144
6.10	Final Note	145
Chapter 7.	The IBM Magstar Virtual Tape Server	147
7.1	Now Announced the IBM Magstar Virtual Tape Server	148
7.1.1	Virtual Tape Server for IBM 3494 Tape Library	148
7.1.2	Virtual Tape Server for IBM 3495 Tape Library	149
7.2	Introduction to the IBM Magstar Virtual Tape Server	150
7.2.1	Transparent Capacity Exploitation and Management	150
7.2.2	Fully Integrated in IBM 3494 and IBM 3495 Tape Libraries	151
7.2.3	Integration of Proven IBM Technologies	151
7.3	Virtual Tape Server Key Attributes	153
7.3.1	One VTS Subsystem per IBM 3494 or IBM 3495	153
7.3.2	Defined Physical Configurations	154
7.3.3	Up to 40 TB of Tape Data per Virtual Tape Server Subsystem	155
7.4	Virtual Tape Server Key Concepts	156
7.4.1	Virtual Volumes	157
7.4.2	Virtual Devices	157
7.4.3	Logical Volumes	158
7.4.4	Physical Volumes	158
7.4.5	Physical Devices	159
7.5	Hardware Overview	160
7.5.1	IBM 3494 Tape Library	160
7.5.2	IBM 3495 Tape Library Models L20, L30, L40, L50	161
7.6	IBM Magstar Virtual Tape Server Host Software Support	163
7.6.1	MVS/ESA	163
7.6.2	VM/ESA	164
7.6.3	VSE/ESA	164
7.7	IBM 3494 Host and Library Manager Attachment	165
7.7.1	ESCON Host Attachment	165
7.7.2	Library Manager Attachment	165
7.7.3	IBM 3494-D12 and IBM 3494-B16 Frame Connections	166
7.8	IBM 3494 Virtual Tape Server Configuration Guidelines	167
7.8.1	The L12/L14 Frame Can Be Without Drives	167
7.8.2	The D12/B16 Frame Must Be Within The First Eight Frames	167
7.8.3	The D12 Frame Must Always Be to the Left of the B16 Frame	168
7.8.4	The D12 and B16 Frames Must Directly Attach to One Another	168
7.8.5	A Modem Must Be Supplied for the IBM 3494-B16 Frame	168
7.9	New IBM 3494 Features, Their Codes and Model Upgrades	169
7.9.1	Features and Their Codes	169
7.9.2	Model Upgrades	170
7.10	IBM 3494 Environmental Requirements	172

7.11 IBM 3495 Virtual Tape Server Configuration Guidelines	173
7.11.1 One IBM 3495-B16 Must Be Installed	173
7.11.2 One IBM 3590-A14 Frame Must Be Installed	173
7.11.3 Library Manager Attachment	174
7.11.4 IBM 3495-B16 and IBM 3590-A14 Must Be Installed Side by Side	174
7.11.5 Reduction of IBM 3495 Storage Cells when a VTS is Installed	174
7.11.6 A Modem Must Be Supplied for The IBM 3495-B16	174
7.12 IBM 3495 Virtual Tape Server Frame Placement	175
7.13 IBM 3495 Virtual Tape Server Models and Features	177
7.13.1 IBM 3590 Model A14 Plus Feature 9010	177
7.13.2 IBM 3495 Model B16 Feature Codes	177
7.13.3 Feature Codes For IBM 3495 Model L20, L30, L40 and L50	178
7.14 IBM 3495 Environmental Requirements	179
7.15 Logical Data Flow	180
7.16 Scratch Mount Scenario	181
7.17 Specific Mount Scenario	184
7.17.1 Volume in Tape Volume Cache	184
7.17.2 Volume not in Tape Volume Cache	184
7.18 Space Reclamation	185
7.18.1 Tape Volume Cache	185
7.18.2 Stacked Magstar Cartridges	186
7.19 Virtual to Real Volume Comparisons	188
7.19.1 Virtual Volume	188
7.19.2 Physical Volume	189
7.19.3 Virtual Volume Advantages	189
7.20 Sizing Guidelines	191
7.21 Sizing a Virtual Tape Server	193
7.22 Real and Virtual 3490E Device Coexistence	195
7.22.1 Physical Installation	195
7.22.2 Library Manager View	195
7.22.3 Host View	196
7.23 Virtual Tape Server Installation Tasks	197
7.23.1 Physical Installation and Checkout	197
7.23.2 Logical Partitioning	197
7.23.3 Teach and Inventory	197
7.23.4 Hardware Configuration Definition (HCD) Required For Library Devices	198
7.23.5 Define the New Library to the Host	198
7.23.6 Define Volume Serial Number Ranges	198
7.23.7 Add Magstar Cartridges	199
7.23.8 Define Fast-Ready Categories	199
7.23.9 Define Reclamation Schedule	199
7.24 Implementing the Virtual Tape Server	200
7.24.1 MVS/ESA Environments	200
7.24.2 VM/ESA Environments	201
7.24.3 VSE/ESA Guests	202
7.25 Migration to the IBM Magstar Virtual Tape Server (VTS)	203
7.25.1 Which Data?	203
7.25.2 How to Migrate?	204
7.25.3 Migration from Physical IBM 3490E	204
7.26 Monitoring the IBM Magstar Virtual Tape Server (VTS)	206
7.26.1 Event Logging	206
7.26.2 Library Reporting	208
7.26.3 Library Manager Displayed Information	208
7.27 Operating the IBM Magstar Virtual Tape Server (VTS)	210

7.27.1 Library Manager Updates	210
7.27.2 Vaulting	210
7.27.3 Error Recovery	211
Chapter 8. IBM Magstar 3590 Silo-Compatible Tape Subsystem	213
8.1 STK Trademarks	214
8.2 Why Use IBM 3590 Magstar in an STK Silo?	216
8.3 Configuration Overview	218
8.4 IBM 3590 Model C12	220
8.4.1 IBM 3590-C12 Features	222
8.4.2 IBM 3590-B1A Features	223
8.5 IBM 3591 Model A01	224
8.5.1 IBM 3591-A01 Features	226
8.6 Allowed Device Combinations	227
8.7 Multi-ATL Scratch Tape Allocation	229
8.8 Multi-ATL Specific Tape Allocation	231
8.9 Installation and Operation	233
8.9.1 Installation	233
8.9.2 Operation	236
8.10 Migration Path to IBM 3494	238
Appendix A. Sample Cleaning Program	241
Appendix B. Special Notices	243
Appendix C. Related Publications	247
C.1 International Technical Support Organization Publications	247
C.2 Redbooks on CD-ROMs	247
C.3 Other Publications	247
How To Get ITSO Redbooks	249
How IBM Employees Can Get ITSO Redbooks	249
How Customers Can Get ITSO Redbooks	250
IBM Redbook Order Form	251
Index	253

Figures

1.	Tape Technology History	2
2.	Half-Inch Cartridge Tape History	5
3.	IBM 3590 Magstar ESCON Configurations	6
4.	IBM 3590 Magstar SCSI Configurations	8
5.	Design Targets and Market Requirements	9
6.	New Technology	11
7.	Metal Particle Medium	13
8.	Interleaved Longitudinal Recording	14
9.	Serpentine Interleaved Track Sets	15
10.	Why Use Longitudinal Technology?	17
11.	IBM Tape Products	18
12.	IBM 3590 Tape Space Utilization	20
13.	Now Announced the IBM Magstar Virtual Tape Server	21
14.	Magstar Tape Drive	24
15.	Magstar Tape Drive Schematic Comparison	27
16.	IBM 3590 Drive Models	28
17.	IBM 3590 Control Unit	30
18.	IBM 3590 Frame	32
19.	IBM 3590 Environmentals	34
20.	IBM 3590 High Performance Tape Cartridge	36
21.	Automatic Cartridge Facility	40
22.	IBM 3590 Operator Panel	42
23.	IBM 3590 Operator Panel Screens	44
24.	ACF Magazine	46
25.	ACF Modes of Operation	48
26.	ACF Manual Mode	51
27.	ACF Accumulate Mode	53
28.	ACF Automatic Mode	55
29.	ACF System Mode	57
30.	ACF Random Mode	59
31.	ACF Mode Enabling and Disabling	62
32.	IBM ES/9000 and S/390 Configurations	66
33.	IBM 3495 Configurations	69
34.	IBM 3495 Mixed Configurations	71
35.	IBM AS/400 Configurations	73
36.	IBM RISC/6000 Configurations	75
37.	IBM 3494 Configurations	78
38.	IBM 3494 Model Summary	82
39.	IBM 3494 Capacity Guidelines	85
40.	IBM 3590 Feature Codes	86
41.	IBM 3590 Subsystem Host Interfaces	90
42.	IBM 3590 Software Support Overview	94
43.	IBM 3590 Channel Command for ES/9000 and S/390 Systems	96
44.	New STAGE Channel Command	98
45.	Logical Block Number	100
46.	IBM 3590 Support for MVS/ESA	101
47.	IBM 3590 Support for DFSMS/MVS: Basic	104
48.	IBM 3590 Support for DFSMS/MVS: SMS and AMS	107
49.	IBM 3590 Support for DFSMS/MVS: ISMF, DFSMShsm, and DFSMSrmm	109
50.	IBM 3590 Support for DFSMS/MVS: OAM and LCS	112
51.	IBM 3590 Support for DFSMS/MVS: LCS (continued)	115

52.	IBM 3590 Support for JES3	117
53.	VM/ESA Version 2	119
54.	OS400 Version 3 Release 1	122
55.	AIX/6000 Version 3.2.5 and Version 4.1.1	123
56.	SunOS and Solaris	125
57.	ADSM for AIX/6000 and SunOS/Solaris	127
58.	Other Software Supported for IBM 3590	128
59.	IBM 3490E ESCON Data Rate	132
60.	IBM 3490E ESCON Data Rate Chart	135
61.	IBM 3490E SCSI Data Rate	137
62.	IBM 3490E SCSI Data Rate Chart	138
63.	IBM 3590 ESCON Data Rate	139
64.	IBM 3590 SCSI Data Rate	140
65.	IBM 3590 SCSI Data Rate Chart	141
66.	IBM AS/400 Data Rate Chart	142
67.	Autoblocking and Compression	143
68.	Title Slide of the IBM Magstar Virtual Tape Server Presentation	147
69.	Now Announced the IBM Magstar Virtual Tape Server	148
70.	Introduction to the IBM Magstar Virtual Tape Server	150
71.	Virtual Tape Server Key Attributes	153
72.	Virtual Tape Server Key Concepts.	156
73.	Hardware Overview	160
74.	IBM Magstar Virtual Tape Server Host Software Support	163
75.	IBM 3494 Host and Library Manager Attachment	165
76.	IBM 3494: VTS Configuration Guidelines	167
77.	New IBM 3494 Features, Their Codes and Model Upgrades	169
78.	IBM 3494 Environmental Requirements	172
79.	IBM 3495 Virtual Tape Server Configuration Guidelines	173
80.	IBM 3495 Virtual Tape Server Frame Placement	175
81.	IBM 3495 Virtual Tape Server Models and Features	177
82.	IBM 3495 Environmental Requirements	179
83.	Logical Data Flow	180
84.	Scratch Mount Scenario	181
85.	Specific Mount Scenario	184
86.	Space Reclamation	185
87.	Comparison of Virtual to Real Volumes.	188
88.	Sizing Guidelines	191
89.	Sizing a Virtual Tape Server	193
90.	Real and Virtual 3490E Device Coexistence	195
91.	Virtual Tape Server Installation Tasks	197
92.	Implementing the Virtual Tape Server	200
93.	Migration to the IBM Magstar Virtual Tape Server (VTS)	203
94.	Monitoring the IBM Magstar Virtual Tape Server	206
95.	Operating the IBM Magstar Virtual Tape Server (VTS)	210
96.	STK Trademarks	214
97.	Why Use IBM 3590 in an STK Silo?	216
98.	Configuration Overview	218
99.	IBM 3590 Model C12	220
100.	IBM 3591 Model A01	224
101.	Allowed Device Combinations	227
102.	Multi-ATL Scratch Tape Allocation	229
103.	Multi-ATL Specific Tape Allocation	231
104.	Installation and Operation	233
105.	Migration Path to IBM 3494	238
106.	JCL for Sample Cleaning Program	241

Tables

1.	IBM Tape Technology History	2
2.	IBM 3590 High Performance Tape Subsystem Products	8
3.	Tape Media, Capacity, and Data Transfer Rate by Device Type	19
4.	IBM 3494-L10 Upgrade Features	84
5.	IBM 3590 Feature Codes	87
6.	Supported Configurations for the IBM 3490E and IBM 3590	91
7.	DFSMSHsm User Commands Affected by IBM 3590 Support	110
8.	Effective Data Rates per Path to an IBM 3490E Tape Drive	134
9.	Effective Data Rates per Path to an IBM 3490E Tape Drive	138
10.	Effective Data Rates per Path to an IBM 3590 Tape Drive	141
11.	IBM 3590-C12 Physical Characteristics	221
12.	IBM 3590-C12 Features	222
13.	IBM 3590-B1A Features	223
14.	IBM 3591-A01 Software Support	225
15.	IBM 3591-A01 Physical Characteristics	225
16.	IBM 3591-A01 Features	226
17.	APARs	234

Preface

This document is intended to help customers and IBM technical professionals understand and evaluate the IBM 3590 High Performance Tape Subsystem that uses the Magstar tape drive. This document describes the functions, features, and configuration considerations of the IBM 3590 tape subsystem as well as the technology used for the new product. It provides information that can be used to help customers plan and prepare their IBM 3590 tape subsystem implementation.

In September 1996, we add descriptions of the IBM Magstar Virtual Tape Server subsystem that is provided with IBM 3494 and IBM 3495 Automated Tape Library Dataservers. We also add technical description regarding IBM 3590-C12 Silo-Compatible frame that enable to attach IBM 3590 tape drives to StorageTek "Silo" tape library.

This document is written for storage administrators, systems programmers, and other technical professionals involved with and interested in storage subsystems.

How This Redbook Is Organized

This redbook contains 269 pages. It is organized as follows:

- Chapter 1, "Introduction to the New Technology"

This chapter briefly describes the IBM 3590 High Performance Tape Subsystem, its technology, and history. It also describes the longitudinal recording technology implemented in the new tape subsystem and explains why IBM has chosen to stay with longitudinal recording for start and stop as well as streaming tape applications.

- Chapter 2, "IBM 3590 High Performance Tape Subsystem Hardware Description"

This chapter describes the IBM 3590 High Performance Tape Subsystem hardware, including the newly developed IBM 3590 High Performance Tape Cartridge.

- Chapter 3, "IBM 3590 Automatic Cartridge Facility Operations"

This chapter describes the IBM 3590 Automatic Cartridge Facility (ACF), which automates the cartridge loading operation. The chapter also explains the function and use of the six ACF modes.

- Chapter 4, "Configuration Guidance"

This chapter provides some guidance for configuring the IBM 3590 High Performance Tape Subsystem with such IBM platforms as the ES/9000, S/390, AS/400, RISC/6000, and POWERparallel SP2 systems. The configurations for the IBM 3494 and 3495 Automated Tape Library Dataserver and the new IBM 3494 Automated Tape Library Dataserver models are also described.

- Chapter 5, "Software Support for the IBM 3590 High Performance Tape Subsystem"

This chapter provides information on the levels of software support for the IBM 3590 High Performance Tape Subsystem and the new functions and features provided by the software.

- Chapter 6, “Tape Performance Considerations”

The purpose of this chapter is to discuss the IBM 3490E tape subsystem performance characteristics and how they relate to effective data rate and overall performance of the IBM 3490E tape subsystem. The discussion is then extended to the new IBM 3590 High Performance Tape Subsystem, developing ideas and issues of most importance when considering the improvements in native drive performance available with IBM 3590 Tape Drive.

- Chapter 7, “The IBM Magstar Virtual Tape Server”

In this chapter, we provide technical descriptions regarding Virtual Tape Server that was newly announced in September 1996.

- Chapter 8, “IBM Magstar 3590 Silo-Compatible Tape Subsystem”

In this chapter, we provide technical descriptions regarding IBM 3590-C12 Silo-compatible frame that enable to attach IBM 3590 tape drives to StorageTek “Silo” library.

- Appendix A, “Sample Cleaning Program”

This appendix shows how to get a sample cleaning program for IBM 3590 tape drives that are installed in the StorageTek Automated Cartridge System.

The Team That Wrote This Redbook

This redbook was produced by a team of specialists from around the world working at the International Technical Support Organization San Jose Center.

This project was designed and managed by:

Minoru Massaki International Technical Support Organization,
San Jose Center

The authors of the first edition of this document were:

Christina Coutts IBM United Kingdom
Kjell E Nyström IBM Nordic
Minoru Massaki ITSO San Jose Center

The authors of the second edition of this document were:

Cameron Whitnall IBM Australia
Taisei Takai IBM Japan
Wolfgang Wettig IBM Germany
Babette Häusser IBM Germany
Kjell E Nyström IBM Nordic

Thanks to the following people for the invaluable advice and guidance provided in the production of this document:

Darrel L. Armstrong IBM Tucson
David C. Graves IBM Tucson
Jon W. Peake IBM Tucson
Daniel P. Sheehy IBM Tucson

Thanks to the following people for their invaluable contributions to this project:

Joe-Ming Cheng IBM San Jose
Maggie Cutler Technical Editor
Kirby G. Dahman IBM Tucson
Don Gerheim IBM Tucson
Peter Kasper IBM Austria
Geoff Littlewood IBM UK
Nigel Morton IBM UK
Jukka Myyrylainen IBM UK
Mayank R. Patel IBM San Jose
Richard A. Ripberger IBM Tucson
Stephen L. Schwartz IBM Tucson
Brian F. Sherman IBM Canada
Klaus Steen IBM Denmark
Frans Versteeg IBM Netherlands
Lee R. Weaver IBM Tucson

This publication is the result of a residency conducted at the International Technical Support Organization, San Jose Center.

Comments Welcome

We want our redbooks to be as helpful as possible. Should you have any comments about this or other redbooks, please send us a note at the following address:

redbook@vnet.ibm.com

Your comments are important to us!

Chapter 1. Introduction to the New Technology

This chapter gives an overview of the IBM 3590 High Performance Tape Subsystem and the Magstar tape drive, a key component of the subsystem. The Magstar tape drive features in the IBM 3590 High Performance Tape Subsystem. We describe the longitudinal recording technology implemented in the new tape subsystem and explain why IBM has chosen to stay with longitudinal recording for start and stop tape applications as well as streaming tape applications.

IBM has carefully considered the requirements of future tape subsystems for high performance computer data storage applications. IBM has also assessed the various technology options for high performance systems and has concluded that the implementation of a new technology for longitudinal recording is the optimum choice. The new technology can significantly increase the performance of longitudinal recording while considerably improving reliability and retaining economic advantages.

The longitudinal recording format and technology were chosen to provide potential growth in both capacity and data rate by factors of 2 to 3. Our design meets the objective of maximizing the three critical factors of **performance**, **reliability**, and **affordability**.

Tape Technology History



First generation

Second generation

Third generation

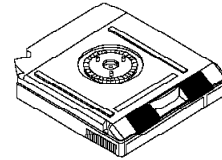
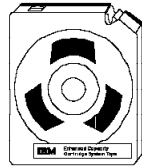
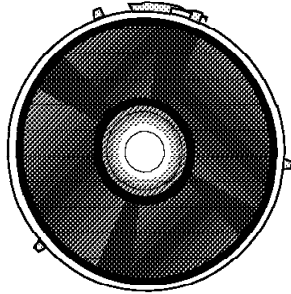

Manual

Automated

Managed



© IBM Corporation 1995
04/03/95

TTHIST
NTPGCH1.PRS

Figure 1. Tape Technology History

1.1 Tape Technology History

The history of longitudinal recording formats generally coincides with the history of tape recording. IBM has consistently been the leader in the development of new longitudinal recording formats designed specifically for computer data storage applications. The progression of longitudinal recording from the early 7-track devices to 9-track, later 18-track, and recently 36-track has always been characterized by **industrial strength** tape devices. For more information on tape devices, see Table 1 on page 2.

Table 1 (Page 1 of 2). IBM Tape Technology History

Year	Product	Capacity (MB)	Transfer Rate (KB/s)
1952	IBM 726	1.4	7.5
1953	IBM 727	5.8	15
1957	IBM 729	23	90
1965	IBM 2401	46	180
1968	IBM 2420	46	320
1973	IBM 3420	180	1250
1984	IBM 3480	200	3000
1989	IBM 3490	200	4500
1991	IBM 3490E	400	9000

Year	Product	Capacity (MB)	Transfer Rate (KB/s)
1992	IBM 3490E	800	9000
1995	IBM 3590	10000	20000

- **First generation**

The **first generation** of magnetic tapes, the IBM 726 Tape Unit, was announced on May 21, 1952. The tape medium was stored on a reel, like the one shown in Figure 1 on page 2. The capacity of each reel was 1.4 MB, and the channel data rate was 7.5 KB/s. With this announcement the transition from paper media, such as punched cards or paper tapes, started and lasted for approximately 20 years. The last product in this generation was the IBM 3420 Model 8 with a reel capacity of 180 MB and a data rate of 1.22 MB/s.

The management and handling of these first generation tape reels were manual. Operators mounted and demounted tape volumes, tape librarians managed the tape libraries (shelves), and the tape content was described on stickers on the tape itself and in some kind of manual tape inventory.

Applications used tapes directly, and each file or data set was stored on one or more tape volumes. As magnetic disks were not yet widely used, tapes were not used as backup media. Of course tape was also used as the interchange media to transport data between data centers.

- **Second generation**

The **second generation** of magnetic tapes, the IBM 3480, was announced on March 22, 1984. The tape was stored on a (now familiar) cartridge, which was smaller, much more robust, and easier to handle than the reels. The cartridge capacity was 200 MB, and the channel data rate was 3 MB/s. Once again a transition started from the first generation's tape reels to the second generation's cartridges, and today, approximately ten years later, most installations use only 3480 and 3490 tape technology. The last product belonging to this generation is the IBM 3490E with a tape capacity of 800 MB uncompact (2.4 GB compacted) and a channel data rate of 9 MB/s.

During this second generation several steps were taken to automate tape processing and reduce or eliminate human intervention. Automatic cartridge loaders and automated tape libraries, such as the IBM 3495, were introduced to reduce or eliminate the need for tape operators. Software packages, such as the Removable Media Manager (DFSMSrmm), were implemented to automatically manage the tape volumes.

Applications still used tapes directly and new inventions, such as Improved Data Recording Capability (IDRC), which compacts the data, reduced the number of tape volumes used. Magnetic disks were now widely used for online data, and these second generation tapes therefore became the medium for backup and were introduced as an archive medium. The process of archiving was also automated with products like the Hierarchical Storage Manager (HSM - also a component of DFSMS/MVS, DFSMSshm), using tape as the lowest level in a storage hierarchy. Of course tape was still used as an interchange medium, but networks were also used for that purpose.

- **Third generation**

The *third generation* of magnetic tapes, the IBM 3590 High Performance Tape Subsystem, has been announced. The new cartridge medium has a capacity of 10 GB uncompact (30 GB compacted), and the channel data rate is 20 MB/s. The transition to the new medium may last for only a few years because the medium can coexist with the current media in automated libraries, and many software packages, such as ADSTAR Distributed Storage Manager (ADSM), Backup Recovery and Media Services/400 (BRMS/400), and DFSMSHsm, can easily use the new medium.

The third generation will change our minds from thinking in terms of tape volumes or cartridges to managing tape space (as we have done with magnetic disks) and utilizing the available space most efficiently.

Applications will stop using tape directly because the capacity of the medium far exceeds the average file or data set size. Techniques such as Tape Mount Management (TMM) together with such software as ADSM, BRMS/400, and DFSMSHsm will be used instead, and new technology will automatically provide the capability to fully exploit the IBM 3590 High Performance Tape Cartridge.

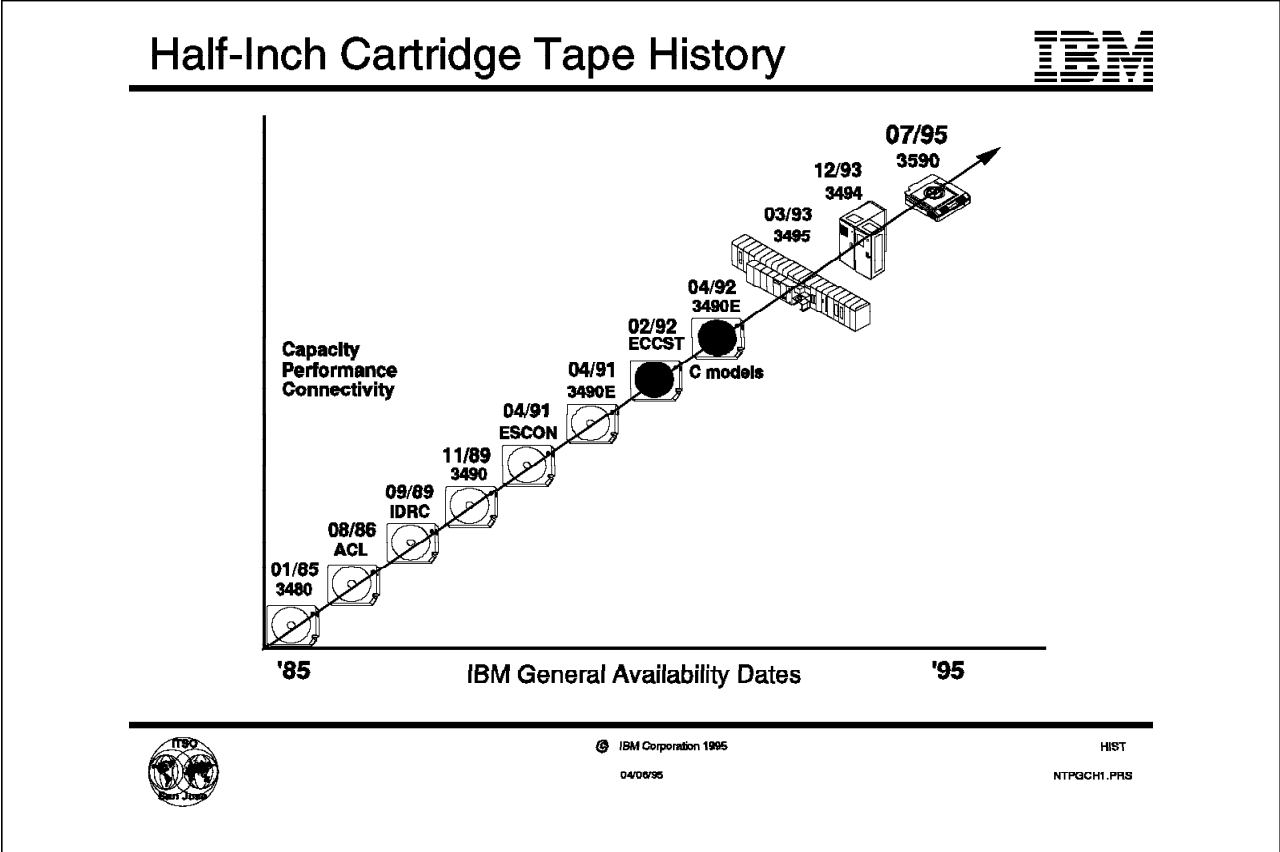

Figure 2. Half-Inch Cartridge Tape History

1.2 Half-Inch Cartridge Tape History

With the most recent introduction of helical scan devices, longitudinal recording appears to offer considerably less capacity and data rate. However, in a commercial environment, capacity and performance are not the only criteria to consider. With current technology implementations, capacity and performance have come to be regarded as the most important factors, but there are nonetheless other critical factors that have not diminished in importance. Helical scan devices are designed for streaming mode, and most commercial applications work in start and stop mode. Earlier devices, such as the IBM 3850 Mass Storage System (MSS), used huge amounts of DASD space as a buffer in order to fully utilize the streaming mode of a helical scan technology and thus avoid continually starting and stopping the device.

The core technology (head, media, and so on) in today's 36-track longitudinal device was developed by IBM more than ten years ago. Since then, IBM has continued to develop technologies that are announced as the IBM 3590 High Performance Tape Subsystem. Technologies implemented in the Magstar 3590 tape drive will significantly change the performance characteristics of longitudinal recording.

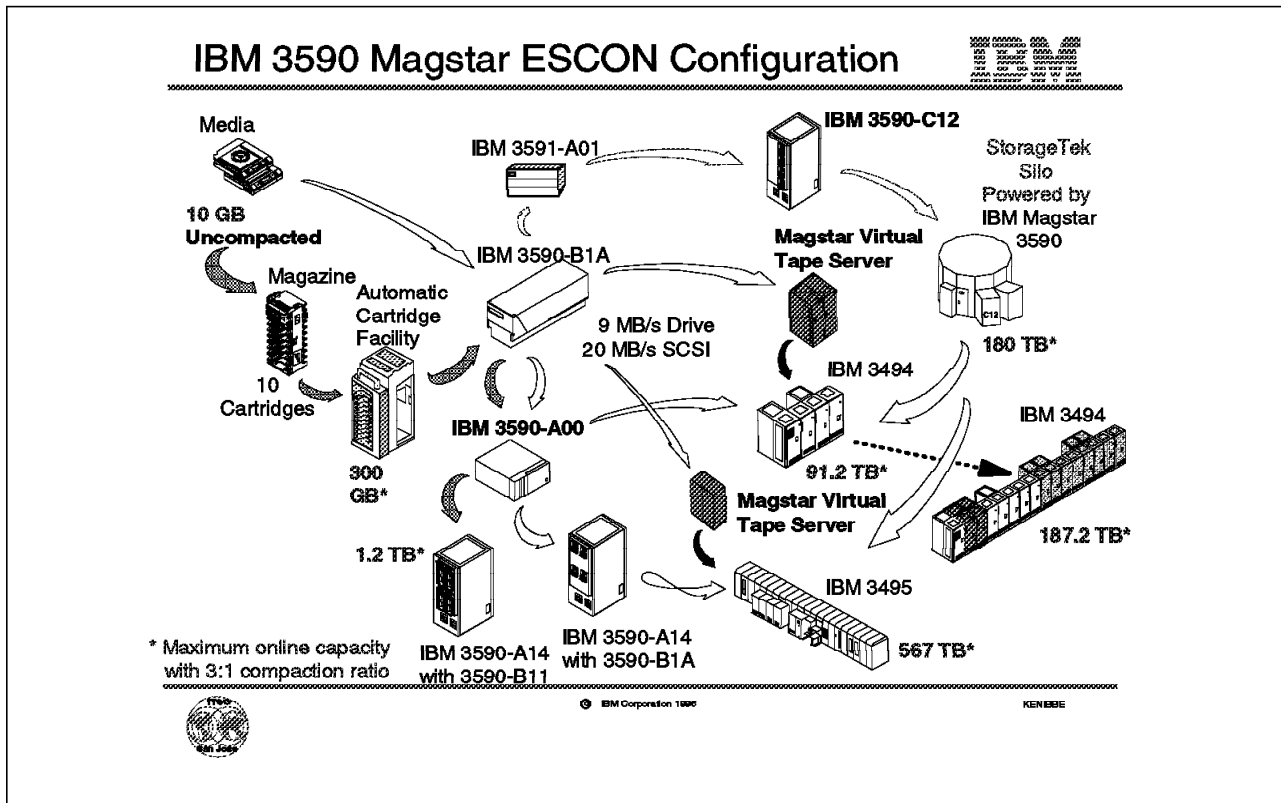

Figure 3. IBM 3590 Magstar ESCON Configurations

1.3 IBM 3590 Magstar Products

In the middle of 1995, IBM announced the **IBM 3590 High Performance Tape Subsystem**, which featured the new **Magstar** tape drive. Highlights of that announcement were:

- **New type of metal particle medium** with binder formulation for reliability and archive life. The new medium is used in a cartridge with a capacity of 10 GB uncompacted data. The new IBM 3590 High Performance Tape Cartridge is specifically developed for the IBM 3590. Its outer shape is compatible with current half-inch cartridges, which permits handling in the IBM 3494 and 3495 Automated Tape Library Dataservers.
- **Ten-cartridge magazine** provides quick loading and removing a set of cartridges to and from Automatic Cartridge Facility (ACF). The magazine can hold up to ten cartridges.
- **Automatic Cartridge Facility**, which can hold one 10-cartridge magazine, plus an eleventh slot for specific mounts, providing an online capacity of more than 300 GB compacted data. The ACF can work in the following two modes in addition to all modes offered by the IBM 3490E Automatic Cartridge Loader (ACL):
 - Accumulate mode, where operator-mounted volumes will, at unload time, be placed in the magazine
 - Random mode, where the ACF can be programmed using host software to mount any of the 10 cartridges in the magazine.

- The host attachment interface of the Magstar tape drive is the **small computer system interface (SCSI)**. If the Magstar tape drive is to be attached to the Enterprise Systems Connection (ESCON) channel, the IBM 3590 Model A00 tape controller is required. The tape drive has its own integrated control unit function, a 9 MB/s drive data rate, and a 20 MB/s SCSI data rate. The Magstar tape drive also has an improved compression algorithm (Ziv-Lempel) which is called IBMLZ1 and will be more efficient than the binary arithmetic compression (BAC) algorithm used in the IBM 3480 and 3490 Tape Subsystem's IDRC.

Up to four **IBM3590 Model B11** tape drives (a Magstar with ACF) can be installed in a standard 19-inch rack, such as the IBM 7202 or the IBM 9309, which gives an online capacity of more than 1 TB (compacted).

The **IBM 3590 Model B1A** tape drive (a Magstar without ACF) can be installed in the IBM 3494 Automated Tape Library Dataserver, which gives an online capacity of more than 90 TB (compacted). The IBM 3590-B1A can coexist with the IBM 3490E in the IBM 3494.

- The **IBM 3590 Model A00** tape controller is used to attach up to four Magstar tape drives to two ESCON channels, with 128 logical paths (64 logical paths per ESCON channel), at a distance of up to 43 km. The IBM 3590-A00 can be installed in the IBM 3494 Model L14 and D14 or in an IBM 3590 Model A14 frame (see below).
- The **IBM 3590 Model A14** is a frame box, similar to the IBM 3490 frame models, where one IBM 3590-A00 tape controller and up to four IBM 3590-B11/B1A tape drives can be installed. The IBM 3590-A14, with one IBM 3590-A00 and four IBM 3590-B1As, as a tape subsystem, can be installed in the IBM 3495 Automated Tape Library Dataserver and coexist with the IBM 3490 and 3490E tape subsystems in the IBM 3495, giving a maximum online capacity of almost 600 TB (compacted).

Note: The IBM 3495 Model M10 Manual Tape Library Dataserver does not support the IBM 3590 High Performance Tape Subsystem.

IBM has enhanced the 3590 family of products by recently announcing some additional features and products. Some of the features of this announcement are:

- The **IBM 3590 Model C12** is an IBM 3590 Silo-Compatible Frame Model. It is designed for attachment to StorageTek Automated Cartridge Systems. Four IBM 3590-B1A drives are installed in an IBM 3590-C12 frame, which are attached to an IBM 3591-A01 ESCON controller. These drives are installed at a special slanted 15 degree angle within the frame, to allow compatibility with the StorageTek robotics.
- The **IBM 3591 Model A01** is the initial ESCON tape controller released for up to four IBM 3590 drives. The IBM 3591-A01 ESCON controller requires no new software as it emulates a 3490E Subsystem. Tapes are written on an IBM 3591-A01 drive in a 3590 media format.
- The **IBM Magstar Virtual Tape Server (VTS)** is a hardware and software (microcode) product designed to provide full capacity utilization for IBM 3590 High Performance Tape Cartridges when housed within an IBM 3494 or 3495 Tape Library. The Virtual Tape Server also provides improved performance for customer tape data access.

The price of the IBM 3590 High Performance Tape Subsystem is comparable to the IBM 3490E. Table 2 on page 8 shows the range of IBM 3590 High Performance Tape Subsystem products

Table 2. IBM 3590 High Performance Tape Subsystem Products		
System	Attachment	Product
ES/9000 S/390 Parallel Server	ESCON	IBM 3590-A14 IBM 3590-A00 IBM 3494/3495 support (IBM 3590-B1A) IBM 3590-C12 (IBM 3591-A01) IBM 3591-A01
RISC/6000	SCSI	IBM 3590-B11 IBM 3590-B1A for IBM 3494
POWERparallel SP2	SCSI	IBM 3590-B11 IBM 3590-B1A for IBM 3494
AS/400	SCSI	IBM 3590-B11 IBM 3590-B1A for IBM 3494
Sun Systems	SCSI	IBM 3590-B11 IBM 3590-B1A for IBM 3494

Figure 4 shows a summary of the possibility for using the IBM 3590 Magstar tape subsystem in a SCSI environment.

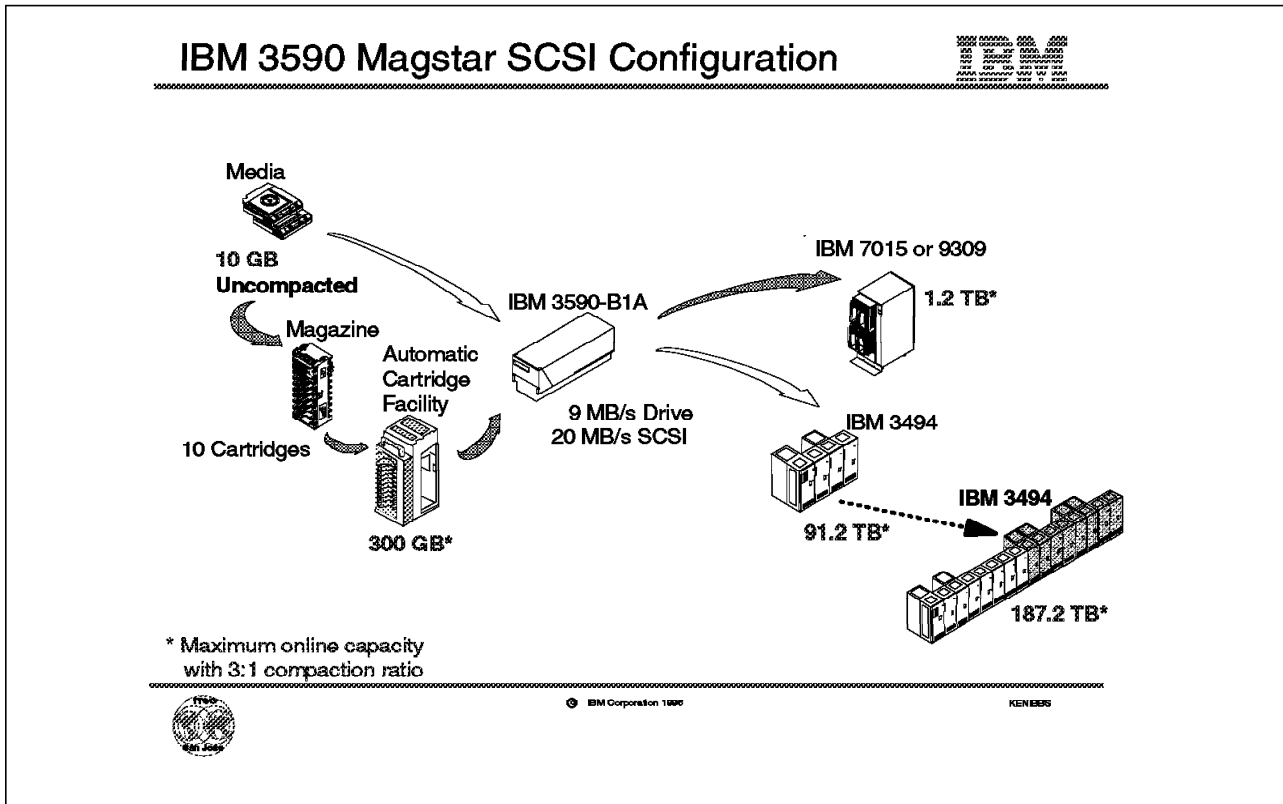

Figure 4. IBM 3590 Magstar SCSI Configurations

Design Targets and Market Requirements



- **Replacement for 3480, 3490, and 3490E**
 - ◆ Establish basis for new extendable family
- **"High performance" in all environments**
 - ◆ Required for today's marketplace
- **Design for broad market acceptance**
 - ◆ Maximize opportunity by addressing all market uses
- **Introduce range of automation options**
 - ◆ Large, intermediate, and small-scale automation
- **Affordability**
 - ◆ Design for low cost, technology reuse, large manufacturing base



© IBM Corporation 1995

04/08/95

DSGNTGT

NTPGCHI.PRS

Figure 5. Design Targets and Market Requirements

1.4 Design Targets and Market Requirements

The design targets and market requirements for the IBM 3590 High Performance Tape Subsystem are:

- **Replacement for 3480, 3490, and 3490E**

The IBM 3480 provided a foundation for 10 years of growth and technological advancement. The IBM 3590 uses the best of the 3480 and 3490 technology by retaining the reliability of the mechanical drive components. Advances in recording technology allow the IBM 3590 to establish the basis for a new family of tape drives that offer large gains in recording density, data reliability, and performance.

- **High performance in all environments**

The IBM 3590 will be available for many operating platforms. Regardless of platform, performance will be improved over the IBM 3480 and 3490 technology.

- **Design for broad market acceptance**

The IBM 3590 High Performance Tape Subsystem is designed for use in a variety of environments. By using the same basic hardware for a tape product that is used in several markets, efficiencies are realized for customers and IBM. Customers with multiple platforms benefit, for example, from short operator training periods and easy conversion from SCSI to ESCON.

- **Introduce range of automation options**

The need to lower operational costs led the drive toward automated tape systems. The rise of distributed systems now calls for a range of automation options. Small tape systems, for example tape systems requiring just a few terabytes of data, need a small amount of reliable automation for unattended backups and other data storage needs. Intermediate systems (for example, distributed servers) need a reasonable amount of automation. The IBM 3590 offers the large capacity of a single cartridge along with the ability to integrate the tape drive in small IBM tape libraries (the IBM 3494 Tape Library Dataserver).

Even intermediate and large systems without a tape library will benefit by using the Cartridge Magazine to reduce operator mount time.

- **Affordability**

Many different factors combine to make the IBM 3590 affordable. From a cost-per-megabyte perspective, the IBM 3590 reduces costs by offering the ability to store enormous amounts of data on a single cartridge. From a raw purchase standpoint, customers benefit from the multiple markets to which the IBM 3590 is offered (economies of scale benefits are realized).

New Technology



Objectives

- **Performance**
 - Storage capacity
 - Transfer rate
- **Reliability**
 - Data integrity
 - Availability
- **Affordability**
 - Comparable price
 - Investment protection

Options

- **Extend current technology**
 - Minor performance improvements
 - Minor reliability improvements
 - Price comparable with IBM 3490E
- **Helical scan**
 - Significant performance improvements
 - Potentially lower reliability
 - Considerably higher in price
- **New longitudinal technology**
 - Significant performance improvements
 - Significant reliability improvements
 - Price comparable with IBM 3490E



© IBM Corporation 1995
01/31/95

OBJOPT
NTPG.PRS

Figure 6. New Technology

1.5 New Technology

We discuss the design objectives and technology options for the IBM 3590 High Performance Tape Subsystem.

1.5.1 Objectives

When new tape technologies are included in product development, it is important to consider all objectives. The list of design objectives can be long, but overall three critical factors are evident:

- **Performance** - improve storage capacity to reduce space and operator activity, and increase data transfer rate to the limit of existing channel interfaces.
- **Reliability** - increase data integrity to accommodate data capacity increases, that is, so that data integrity overall remains constant or is improved when compared with previous lower-capacity devices. As tape capacity increases, the residency time for a tape in a drive will increase, and the availability must be improved accordingly.
- **Affordability** - maintain purchase price and maintenance expense at a comparable level with current products. To protect customer investments, a new tape subsystem ideally should be able to coexist with IBM 3490 products in an IBM 3494 or 3495 Automated Tape Library Dataserver.

1.5.2 Options

How well a new product addresses these three critical factors is directly dependent on the choice of core technologies. IBM has evaluated future development potentials, which are broadly outlined as the following three options:

- **Extend current technology** that was originally developed for the IBM 3480 and enhanced for the different versions of the IBM 3490.

Minor performance and reliability improvements are possible, and the price would remain comparable with the price of today's IBM 3490E.

- **Helical scan** was originally developed to store digital information for streaming applications such as the video industry (D1 in 1983) and later enhanced to attach to computers (D2 in 1986). Both implementations use a 19 mm medium, which makes them incompatible with today's medium size of half an inch. The D2 implementation has removable read and write heads, which make this type of device quite large and difficult to service. To overcome some of the issues with D2, a new implementation using a half-inch medium with nonremovable heads (D3) was developed (and used during the Olympic games in Barcelona in 1992).

The performance of helical scan devices for streaming applications is very good, and the capacity of the medium is large. In a helical scan implementation the tape is in forced contact with the rotating read and write heads. If the host system writing the data cannot sustain the data rate of the device, the device will be forced into a stop and start cycle even if a buffer is used. For one pass of the tape, this time-consuming process (of the order of seconds per stop-restart cycle) is executed tens of thousands of times.

The high degree of contact between the tape and the heads in a helical scan implementation results in high wear of both the medium and the heads. The high wear of the heads makes advanced helical scan devices very expensive for computer-attached use in a commercial environment.

- **New longitudinal technology** now announced by IBM (16-track Serpentine Interleaved Longitudinal Recording) significantly improves tape performance and transfer rates without changing the tape speed (2 m/s). A buffer is used and the data compressed before it is written to. In addition it can complete a stop-start cycle in approximately 100 ms. The performance is significantly improved for both start-stop and streaming applications.

The new technology has many new features that significantly improve reliability, such as servo tracks on the tape and the implementation of an improved error correcting code (ECC). A portion of the tape within each cartridge has been reserved for error history; it will be continually updated after each use (read or write), providing statistics that can be used to identify problems with a particular tape as early as possible.

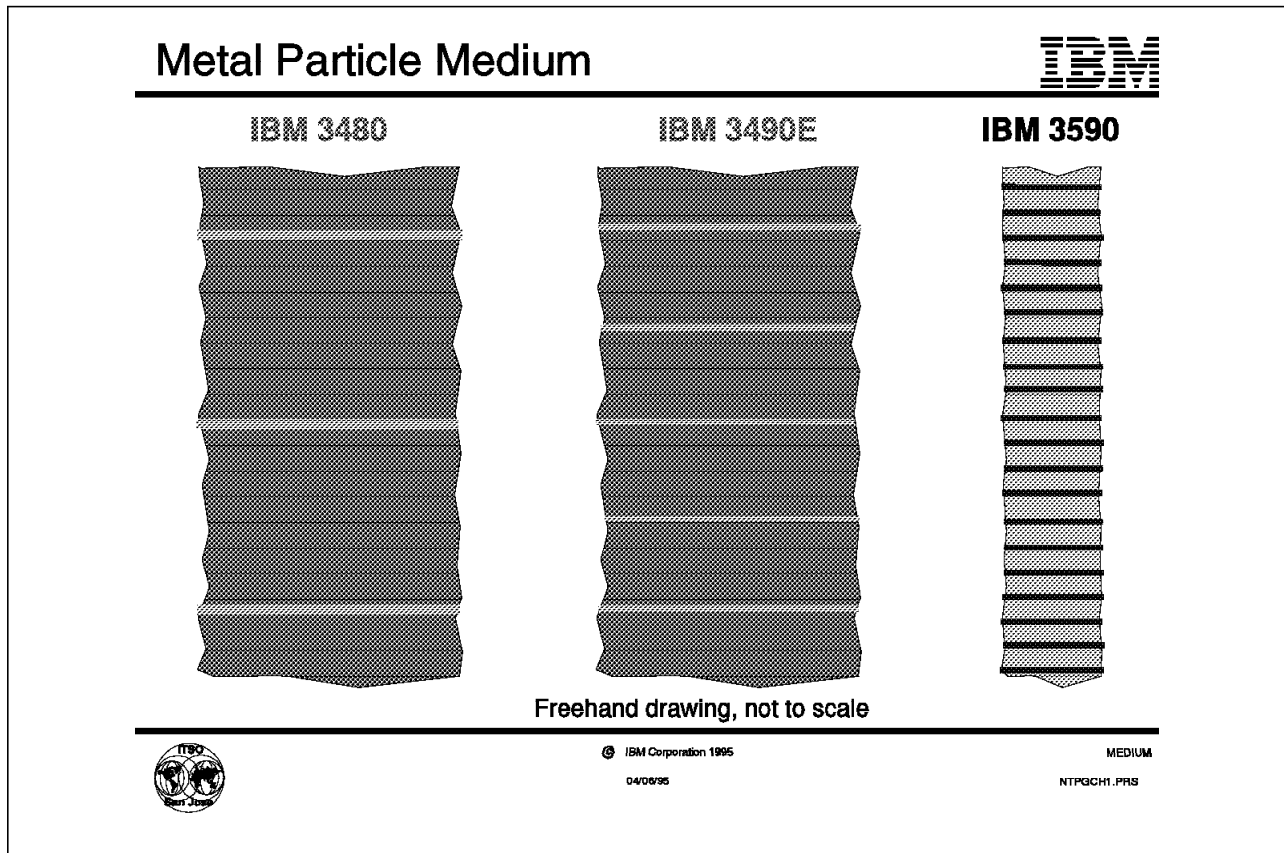

Figure 7. Metal Particle Medium

1.6 Metal Particle Medium

A chromium dioxide medium is used in the IBM 3480 and 3490 cartridges. The new IBM 3590 High Performance Tape Cartridge uses a metal particle medium, which has a significantly increased coercivity and therefore permits a much higher data recording density in comparison with chromium dioxide media.¹ The linear density is proportional to the medium's coercivity, and therefore the density of the IBM 3590 tape is approximately three times that of the IBM 3480 and 3490 as represented in Figure 7. The track density is also improved approximately four times. Metal particle media have been available in the consumer market for many years but has only recently matured sufficiently to provide characteristics suitable for computer data storage.

Advancements in the metal particle coatings and media binders afford reliability and magnetic stability equal or superior to chrome media.

¹ Coercivity is a measure of a material's ability to maintain a magnetic field. Higher coercivity of a medium allows more information to be recorded on the medium and increases the ability of the medium to resist demagnetization.

Interleaved Longitudinal Recording

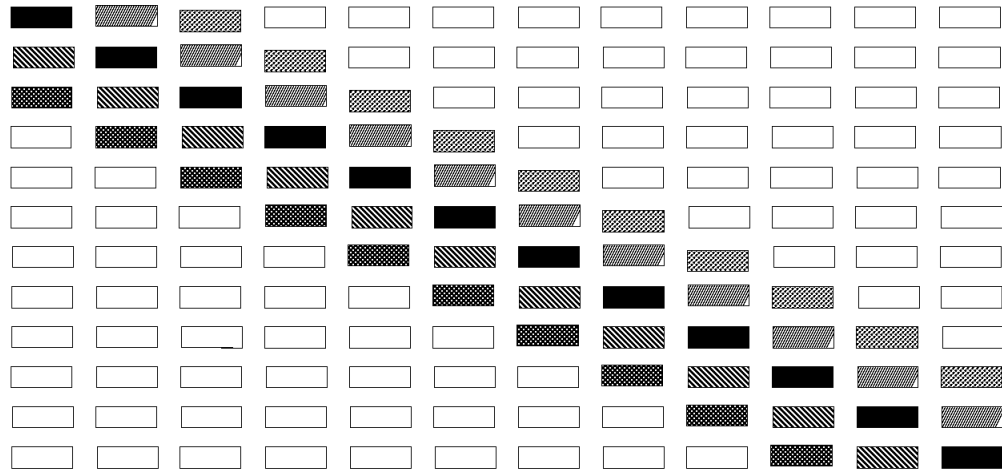

Freehand drawing, schematic view



© IBM Corporation 1995
04/03/95

INTLVE
NTPGCH1.PRS

Figure 8. Interleaved Longitudinal Recording

1.7 Interleaved Longitudinal Recording

Tape media is commonly damaged in two ways:

- Vertical damage, which can occur if the tape is folded for some reason.
- Horizontal damage, such as a scratch along the length of the tape, which can occur during tape movement.

By recording information in an interleaved fashion (that is, spreading the bits of a unit of information along the tape as shown in Figure 8), the probability of being able to recover from either vertical or horizontal damage is increased, because no whole unit of information (a byte) is unrecoverable. Only a few bits within many bytes are damaged, and having only a few bit errors simplifies error recovery and will considerably improve the probability of being able to read a damaged tape.

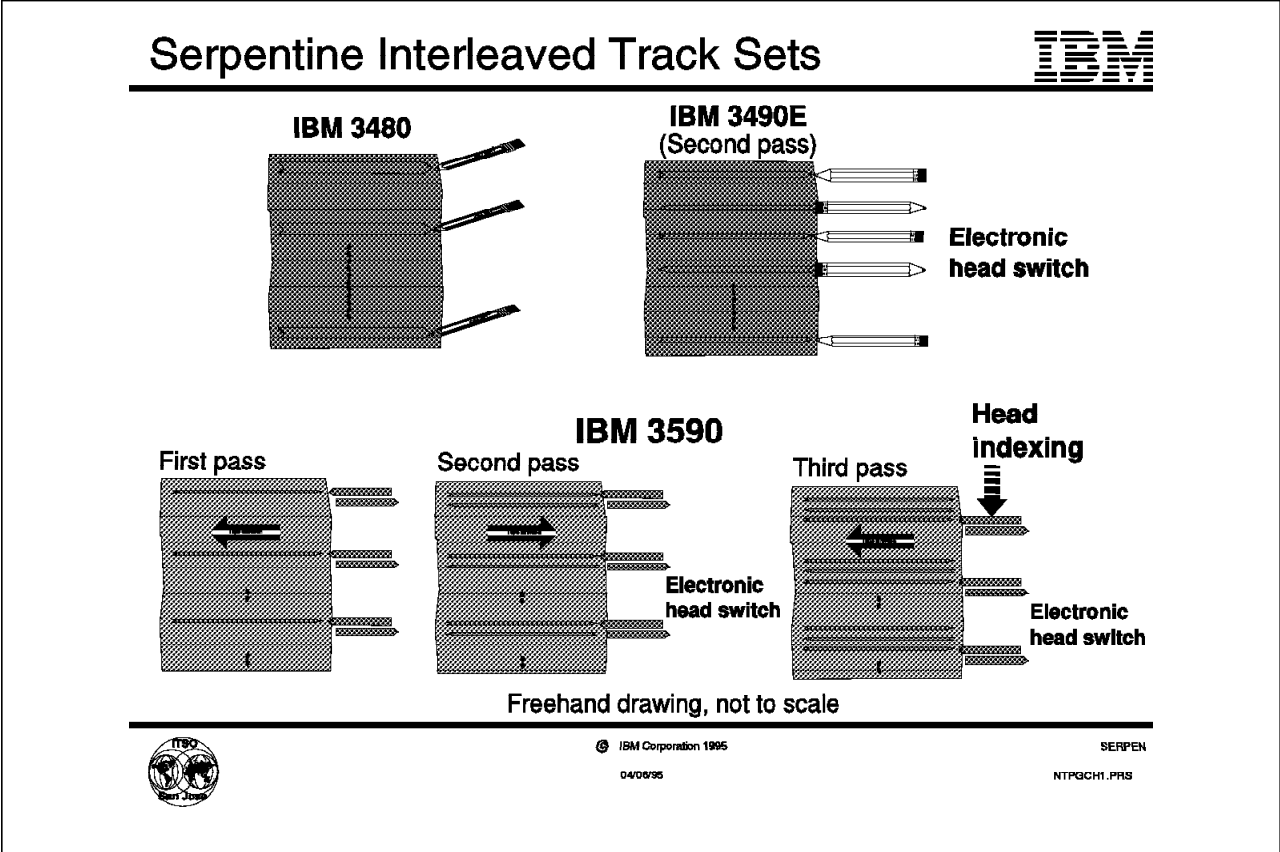

Figure 9. Serpentine Interleaved Track Sets

1.8 Serpentine Interleaved Track Sets

The 18 tracks recorded on IBM 3480 media were used to record ECC information along with the data. The original base IBM 3490 models also used the same 18-track format but were later enhanced in the IBM 3490E models, which implemented two sets of 18 tracks. In an IBM 3490E device the first 18 tracks are recorded when the tape moves in a forward direction until the physical end of the tape is reached. Then, using an electronic head switch (that is, not physically moving the head itself in any direction but switching to a second set of read-write heads), a second set of 18 tracks is recorded when the tape moves in a backward direction until the physical beginning of the tape is reached.

In the IBM 3590 a second generation of thin film magneto resistive (MR) heads is used, which, together with the new tape medium, allows recording with much higher area density, both in number of bits as well as number of tracks per inch. Data is written in blocks of 384KB of user data using a 16-track format (data and ECC information are recorded differently compared to the 18-track format). The first set of 16 tracks is written to the physical end of the tape, and then, using the electronic head switch, 16 different interleaved tracks are written while the tape moves back to the beginning. The head is then indexed (physically moved a fraction of a millimeter) to the next set of 16 tracks. In this way eight sets of interleaved tracks are written to a total of 128 tracks.

Servo tracks are used to ensure accurate reading and writing of the data. The servo tracks on each IBM 3590 tape cartridge are written at the time of manufacture.

The high-speed search has been enhanced to position the drive directly at a certain block without sequentially searching forward and backward through the entire recorded part of the tape.

Why Use Longitudinal Technology?



- **Mechanical simplicity**
 - ◆ Few moving parts
 - ◆ Proven durability
 - ◆ Simple loading mechanism
- **Start-stop operation**
 - ◆ Complete back-hitch cycle in approximately 100 msec
 - ◆ Hundreds of millions of cycles
- **Data integrity**
 - ◆ Numerous concurrent data channels offer several advantages
- **Lower head wear**
 - ◆ Low degree of contact between head and tape minimizes head wear
- **Lower media wear**
 - ◆ Low media wear minimizes debris generation



© IBM Corporation 1995

04/08/95

WHYLN

NTPGCHI.PRS

Figure 10. Why Use Longitudinal Technology?

1.9 Why Use Longitudinal Technology?

In summary IBM has chosen serpentine interleaved longitudinal recording technology to meet the three critical factors, **performance, reliability, affordability**, for the following reasons:

- **Mechanical simplicity** - fewer moving parts are needed in comparison with a helical scan implementation, and proven IBM 3490E technology is used. A simple loading mechanism also contributes to reliability and mechanical simplicity.
- **Start-stop operation** - the very fast back-hitch gives very good performance regardless of application type. This is of particular importance because computer applications in most installations are start-stop applications (such as normal batch or backup operations) and very few are streaming applications (as in the oil or seismic industry).
- **Data integrity** - a new ECC design, interleaved recording, and new hardware technology result in data integrity that is expected to be 100 times higher than that of the IBM 3490E. The large number of concurrent data channels (16 tracks) contributes to data integrity and reliability.
- **Lower head wear** - service expense is minimized and availability improved.
- **Lower media wear** - debris generation is minimized, which in turn minimizes the probability of read or write errors and improves the overall life of the medium.

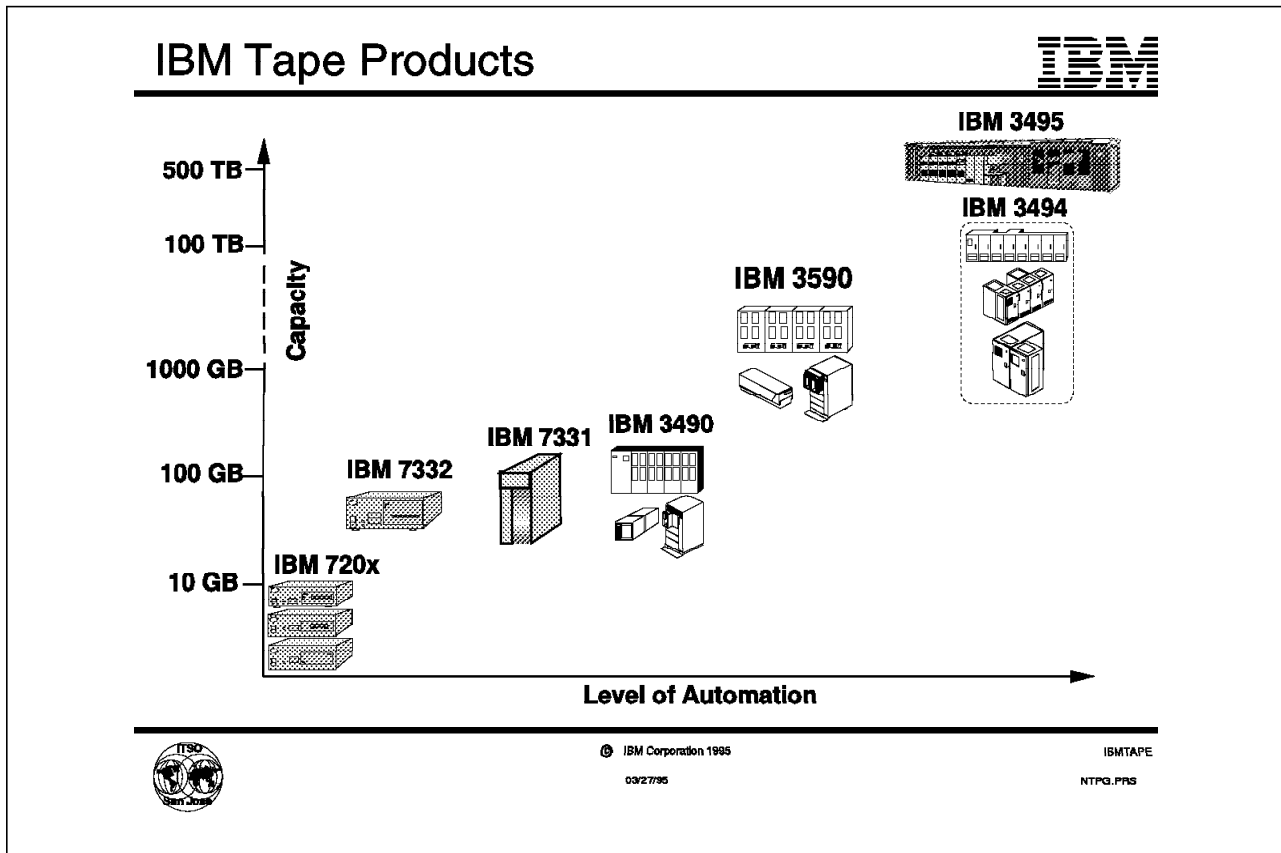

Figure 11. IBM Tape Products

1.10 IBM Tape Products

IBM offers a wide range of tape products, and often it is not easy to decide which product to use.

In selecting a product to solve a business requirement, both the financial and data requirements need to be examined. The amount of data to be stored, the performance when reading and writing data, archive capability, and the level of automation required are all aspects of data requirements that should be reviewed:

- **Capacity:** How much data is planned to be stored for each access to that data? That is, what capacity would each tape ideally have, and how well does the hardware or planned software utilize that capacity? If automation is under consideration, the capacity of the robotics library also needs to be taken into account.

Table 3 on page 19 documents the capacity of the media used by the devices shown in Figure 11. Software products such as ADSM, BRMS/400, or DFSMSHsm will fully utilize any size media.

- **Performance:** What speed is required to access and/or store the data? The batch and backup windows are typically time-constrained environments, and, by alleviating tape contention, a time reduction in the batch and backup processing or more throughput can be realized.

Table 3 on page 19 documents the data transfer rate for the devices shown in Figure 11.

- **Reliability/archivability:** The metal particle medium has improved reliability and has a longer shelf life when compared with the chromium dioxide media used today. Advances in the metal particle coatings and media polymers afford reliability and magnetic stability equal or superior to chrome media.
- **Automation:** Today most installations have some level of automation in the tape environment. This automation may entail the automating of tape messages, the use of cartridge loaders, or a robotics accessor to perform tape mount handling.

Until now, the IBM 3490E was the product of choice for capacity, performance, and reliability. The IBM 3590 High Performance Tape Subsystem provides for 12.5 times the capacity, 3 times the performance, and 100 times the reliability of the IBM 3490E using extended capacity cartridge system tape (ECCST). The IBM 3494 and 3495 Automated Tape Library Dataservers continue to provide library automation while utilizing both IBM 3490E and IBM 3590 technology.

Device Type	Media Type	Media Capacity	Data Transfer Rate
IBM 7207	QIC	1.2 GB	300 KB/S
IBM 7206	4 mm	4 GB	400 KB/S
IBM 7208	8 mm	5 GB	500 KB/S
IBM 7332	4 mm	4 GB	400 KB/S
IBM 7331	8 mm	7 GB	500 KB/S
IBM 3490	CST	400 MB	3 MB/S
IBM 3490E	ECCST	800 MB	3 MB/S
IBM 3590	HPTC	10 GB	9 MB/S

The IBM 3490E offers two different cartridges with a capacity of 400 MB or 800 MB (uncompacted) and 1.2 GB or 2.4 GB (compacted). The IBM 3590 High Performance Tape Cartridge has a capacity of 10 GB uncompacted, or 30 GB if compaction is used.

The IBM 3490E is capable of transferring data between the processor and the tape buffer with a speed of 9 MB/s, and between the buffer and the drive itself with a speed of 3 MB/s. The Magstar tape drive is capable of transferring data between the processor and the tape buffer with either 20 MB/s in the SCSI interface is used or 17 MB/s if ESCON channel interface is used, and between the buffer and the drive itself with a speed of 9 MB/s.

IBM 3590 Tape Space Utilization



ADSM, BRMS/400, DFSMShsm ...



Typical 3390-3 full volume compressed dump



Virtual Tape Server

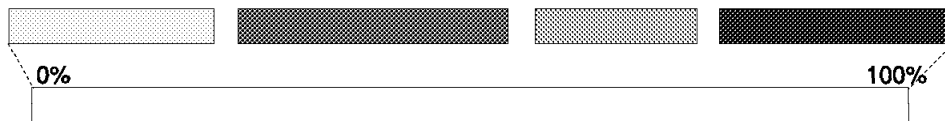

© IBM Corporation 1995
11/19/96

TSUTIL
NTPGCH1.PRS

Figure 12. IBM 3590 Tape Space Utilization

1.11 IBM 3590 Tape Space Utilization

When implementing the IBM 3590 High Performance Tape Subsystem, different application requirements have to be considered from both a capacity and a performance point of view. Applications such as ADSM, BRMS/400, and DFSMShsm can fully use the capacity of the IBM 3590 High Performance Tape Cartridge.

Other applications, for example, a dump of a disk volume, will use only a fraction of the medium capacity. Yet other some applications are time constrained and need the performance of the IBM 3590 tape drive even if the amount of data written does not fully use one cartridge. In an environment with mixed technologies, for example, an IBM 3494 Automated Tape Library Dataserver with both IBM 3490E and IBM 3590 installed, techniques such as system-managed tape in DFSMS should be used to have the system automatically store data in the optimum way.

IBM now has capacity-enabling technology on our ESCON-attached tape libraries. **Virtual Tape Server** uses 3590 drives within IBM 3494 and 3495 Automated Tape Library Dataservers to maximize the customer data content on each IBM 3590 High Performance Tape Cartridge. Virtual Tape Server also provides improved performance for customer tape data access.

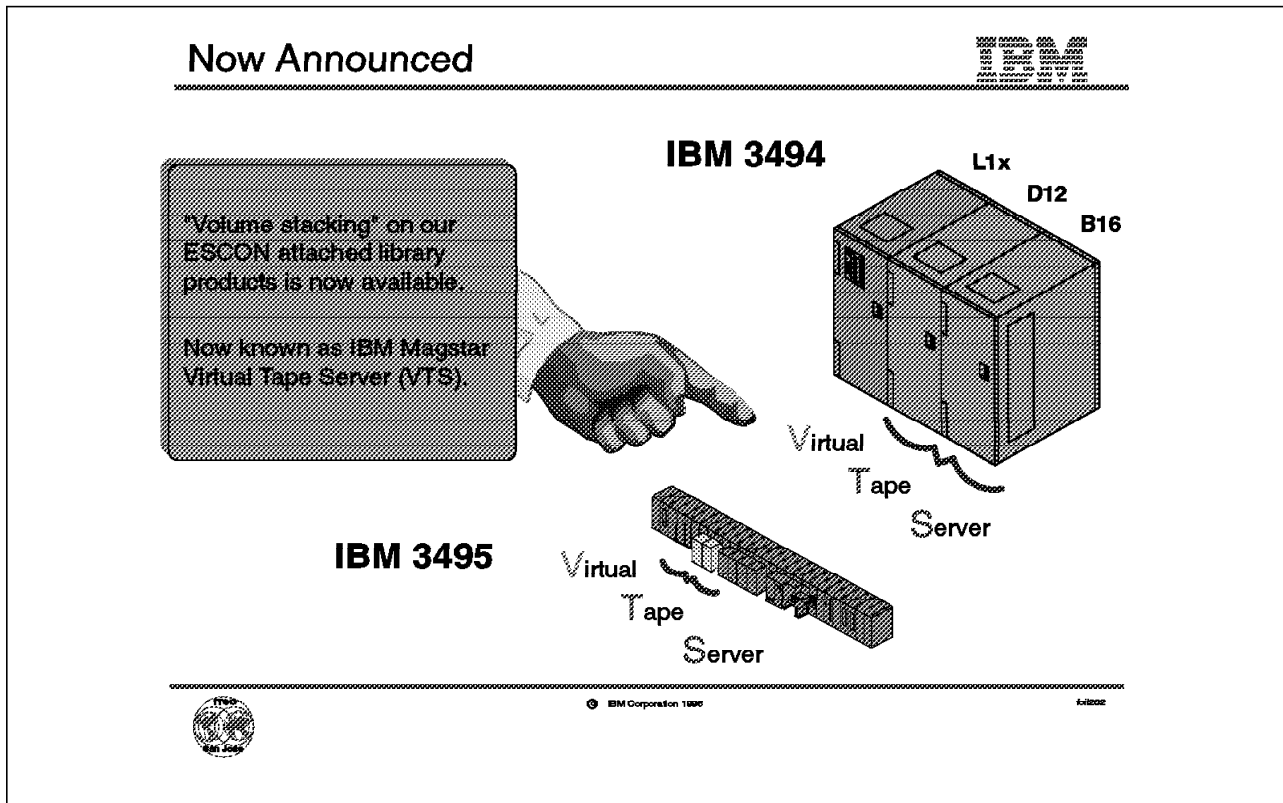

Figure 13. Now Announced the IBM Magstar Virtual Tape Server

1.12 Now Announced the IBM Magstar Virtual Tape Server

In April 1995, together with the announcement of the IBM Magstar 3590 High Performance Tape Subsystem, IBM announced a statement of direction to deliver capacity-enabling technology (also called volume stacking) on our ESCON-attached library products.

Fulfilling this statement of direction, IBM now announces the IBM Magstar Virtual Tape Server (VTS) for IBM 3494 and 3495 Tape Libraries.

1.12.1 Virtual Tape Server for IBM 3494 Tape Library

The VTS subsystem in an IBM 3494 is installed in two frames:

- One IBM 3494-D12 drive unit frame houses the IBM 3590-B1A tape drives that are dedicated to the Virtual Tape Server function.
- One IBM 3494-B16 Virtual Tape Server unit frame which contains the required hardware and microcode to enable full 3590 Magstar tape storage capacity, plus cartridge storage cells.

Figure 13 shows the minimum configuration of a Virtual Tape Server subsystem in IBM 3494 Tape Library including one library unit frame, one drive unit frame, and one Virtual Tape Server unit frame.

See Section 7.8, "IBM 3494 Virtual Tape Server Configuration Guidelines" on page 167 for more detail on IBM 3494 Virtual Tape Server configuration.

1.12.2 Virtual Tape Server for IBM 3495 Tape Library

Installed in an IBM 3495 Tape Library, the Virtual Tape Server subsystem is composed of:

- One IBM 3590-A14 frame that houses four IBM 3590-B1A tape drives which are dedicated to the Virtual Tape Server function. No IBM 3590-A00 ESCON tape controller is required.
- One IBM 3495-B16 Virtual Tape Server unit frame that contains the required hardware and microcode to enable full tape storage capacity.

Figure 13 on page 21 shows the smallest Virtual Tape Server subsystem in an IBM 3495 Tape Library configuration consisting of an IBM 3495 Tape Library Model L20, including the IBM Magstar Virtual Tape Server (VTS).

See Section 7.11, “IBM 3495 Virtual Tape Server Configuration Guidelines” on page 173 for more detail on IBM 3495 Virtual Tape Server configuration.

Chapter 2. IBM 3590 High Performance Tape Subsystem Hardware Description

The IBM 3590 High Performance Tape Subsystem is a completely new tape processing system that provides new levels of function, performance, reliability, and cartridge capacity. The IBM 3590 High Performance Tape Subsystem is a replacement product for the IBM 3480, 3490, and 3490E tape subsystems.

The IBM 3590 tape drive which is called the Magstar tape drive, can be configured in frames or racks, inside or outside an IBM Automated Tape Library Dataserver. Either SCSI or ESCON channel attachments are supported, but parallel channel attachment is not supported. The IBM 3590 High Performance Tape Subsystem is intended for customers who have a requirement to back up large amounts of data or who can use the faster performance.

Magstar Tape Drive



- Modular drive unit
- Native SCSI attachment
 - Separate CU for ESCON attachment
- 9MB/s drive performance
- Control function in drive unit
- Improved compression
 - IBMLZ1 Ziv-Lempel algorithm
 - Autoblocking to 384KB

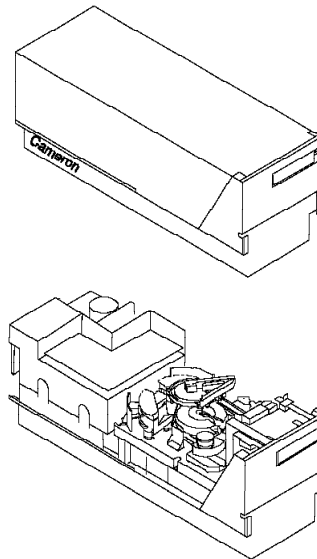

© IBM Corporation 1995
08/21/98

C35901
NTPQCH2.PRS

Figure 14. Magstar Tape Drive

2.1 Magstar Tape Drive

We describe the IBM 3590 tape drive, which is called the Magstar tape drive.

- **Modular drive unit**

Figure 14 shows the basic IBM 3590, with and without the top cover. The unit is 8.8 inches wide, 29.8 inches deep, and 10.5 inches high (221 mm x 750 mm x 262 mm). The drive read/write mechanism and heads and the drive logic are completely new technology; however, as indicated in the figure, the basic load/feed mechanism of the new drive is built on the proven, high-reliability IBM 3490E design.

Other operating characteristics are:

- Read/write tape speed: 2 m/s
- High-speed locate: 5 m/s
- Forward space/Backspace file: 5 m/s
- Rewind speed: 5 m/s
- Full cartridge rewind time: 2 s
- Maximum cartridge rewind time: 60 s
- Average cartridge load time: 16 s

- **Native SCSI attachments**

The drive unit can be attached directly to a 16-bit, fast-and-wide SCSI differential interface. Each drive unit has two such external SCSI interfaces for attachment to RISC System/6000, POWERparallel SP2, AS/400, and Sun

systems. The drive can also be attached to ESCON channels using a separate control-unit device (see 2.4, “IBM 3590 Control Unit” on page 30).

- **9 MB/s drive performance**

The drive data rate at 9 MB/s is three times faster than the IBM 3480, 3490, or 3490E tape drives. This increase in drive data rate, together with the built-in data compression capability, makes it possible to utilize more effectively the full capability of a 20 MB/s fast-and-wide SCSI or a 17 MB/s ESCON channel.

The higher drive data rate is achieved with the much higher areal density possible with the new tape medium. The tape transport speeds and mechanical handling are basically unchanged; they are based on the IBM 3490E design, which is optimized for reliability of the tape medium used.

The integrated control unit function eliminates drive contention and thus enhances performance.

- **Control function in drive unit**

Each IBM 3590 drive has its own integrated SCSI-3 control unit function (with two channel interfaces, for multihost attachment, or availability). This is shown in section 2.2, “Magstar Tape Drive Schematic Comparison” on page 27.

- **Improved compression**

The IBMLZ1 compression algorithm used in the IBM 3590 is based on the Ziv-Lempel algorithm² and Jackson’s³ class of encoding methods. For the IBM 3590 IBMLZ1 compression, a 1024 bytes of history buffer is used. This implementation differs from the IDRC used in the IBM 3490E, which is based on BAC. The IBMLZ1 algorithm is expected to be more effective than IDRC.

As in the IBM 3480, 3490, and 3490E, the data is reblocked in the IBM 3590 buffer (which is 4 MB in size), before it is written to the tape. This is called autoblocking. In the IBM 3590 the autoblocking block size for user data has been increased to 384KB from 128 KB in the IBM 3490E.

The IBMLZ1 compression algorithm is designed for robust and highly efficient compression. Key design objectives for the IBMLZ1 algorithm are:

- Hardware execution efficiency: the hardware architecture should use as few machine cycles as possible to compress or decompress a byte. The architecture should maintain low complexity and use silicon technology effectively. In addition, the smallest number of machine cycles for each byte (this number is called CPB) should be used to compress or decompress data.
- Robust compression: achieve good coding efficiency for broad applications.
- Minimum system integration overhead: the maximum benefit from compression is achieved when the compression can be performed

² Jacob Ziv and Abraham Lempel, “A Universal Algorithm for Sequential Data Compression,” *IEEE Transactions of Information Theory*, Vol. 23, No. 3 (May 1977). Ziv and Lempel have given their names to a class of algorithms known as LZ (not ZL), each of which can be implemented in different ways.

³ Rory D. Jackson and Willi K. Rackl, both of IBM Poughkeepsie Lab, “Data Expansion Apparatus,” described essentially the LZ1; patent filed on June 30, 1976; US Patent 4,054,951, October 18, 1977.

without performance loss. So the algorithm is capable of running at channel speed (20 MB/s for SCSI).

Magstar Tape Drive Schematic Comparison

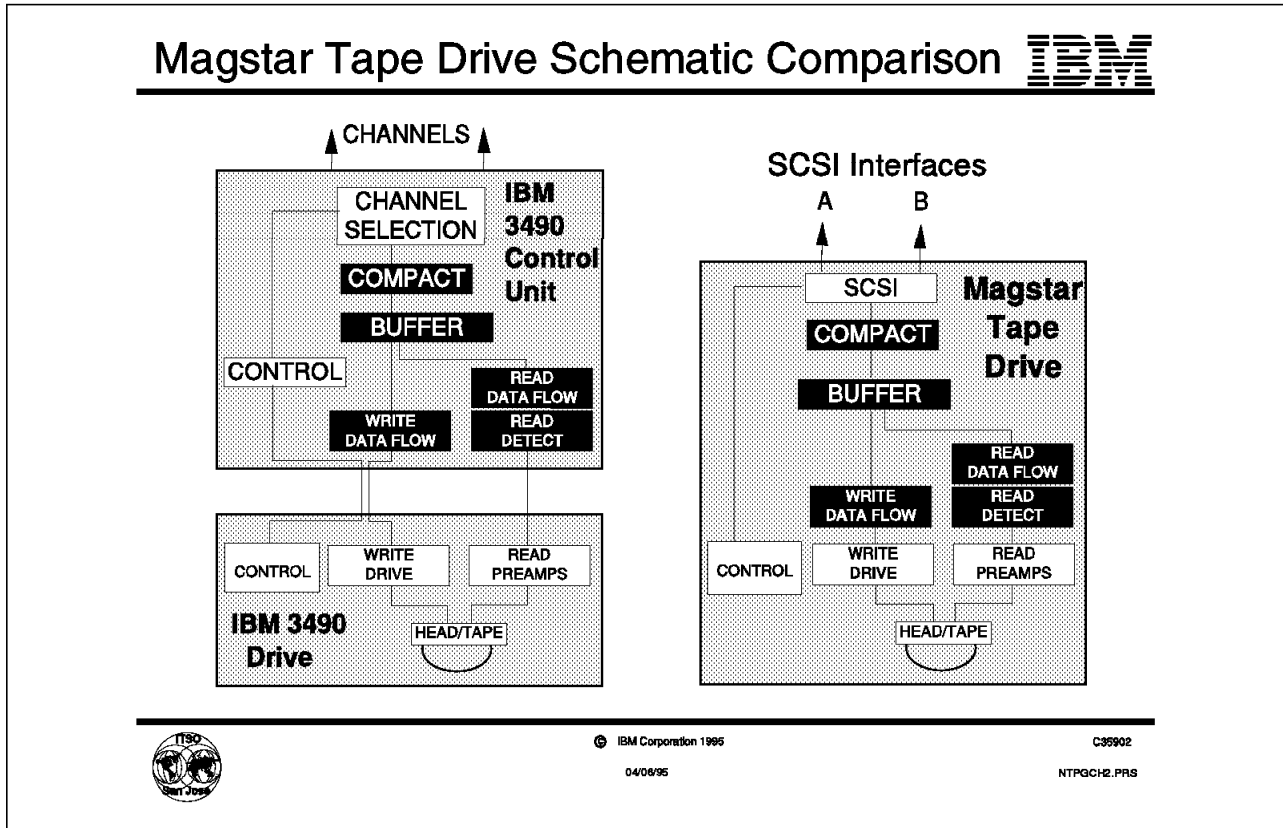

Figure 15. Magstar Tape Drive Schematic Comparison

2.2 Magstar Tape Drive Schematic Comparison

The diagram compares the IBM 3490E drive unit with a separate control unit and the IBM 3590 tape drive unit with an integrated control unit. The IBM 3490E control unit shown represents the IBM 3490-A10, which has the potential to support multiple (up to eight) drive units using its single control unit function. However, only a single drive can be used at a time. In the IBM 3590 the single tape transport has its own control unit function within the drive unit module, including buffering and compaction.

Potential contention of the drives or bottlenecks in the control unit are removed by moving these functions to the individual drive units. The same effect is achieved by dedicating a single drive unit to a single control unit function, as, for example, in the IBM 3490-C10.

IBM 3590 Drive Models



Magstar

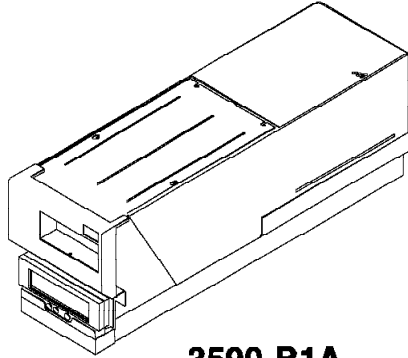

3590-B1A

drive unit single drive automated library

Magstar and ACF

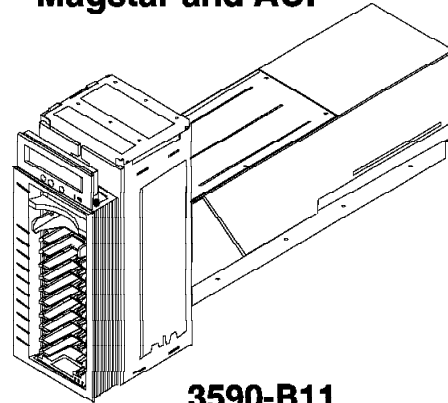

3590-B11

drive unit single drive cartridge loader



© IBM Corporation 1995

04/06/95

C35903

NTPGCH2.PRS

Figure 16. IBM 3590 Drive Models

2.3 IBM 3590 Drive Models

There are two IBM 3590 models: the IBM 3590-B11 and the IBM 3590-B1A. The IBM 3590-B1A is the Magstar and the IBM 3590-B11 consists of a Magstar and an ACF.

The IBM 3590-B11 is a rack-mountable model. It includes a 10-cartridge ACF, which can be quickly loaded using a new magazine. When the IBM 3590-B11 is ordered, a magazine, a cleaner cartridge, one IBM 3590 High Performance Tape Cartridge, and a SCSI terminator are automatically included. It is recommended that a second (spare) magazine be ordered separately. The power cord does not need to be specified, the IBM 3590 is supplied with a short cord to attach to the rack (IBM 7202 or IBM 9309), frame (IBM 3590-A14), or library (IBM 3494 L14 and D14 units).

The IBM 3590-B1A is designed to be installed in the IBM 3494 Automated Tape Library Dataserver and thus has no ACF. It can be installed in new models of the IBM 3494 or 3495 Tape Library, currently installed library frame units can be upgraded to these models. Up to six (up to four if ESCON attached) IBM 3590 Model B1A tape drive units can be installed in a single IBM 3494 frame. Four ESCON attached IBM 3590 Model B1A tape drives can be installed in an IBM 3590-A14 frame installed alongside an IBM 3495.

IBM 3490E and 3590 tape drives can be managed within the same tape library (see Chapter 4, "Configuration Guidance" on page 65).

The meaning of the model numbering is shown in the diagram. Generally for tape subsystems the numbering convention is as follows:

- The first character signifies the type of unit: an *A* for a control unit or a *B* for a drive unit. (The *C* models of the IBM 3490 have the control unit integrated with the drives.)
- The second character indicates the number of drives installed in the unit.
- The third character shows the number of ACFs installed; an *A* indicates that the model is designed to be installed in an automated tape library.

Although this numbering system is generally adhered to for the IBM tape products, it has not been rigorously applied in numbering all previous models, for example, the IBM 3490E models.

Note: The new *14* model numbers of the IBM 3590 and the IBM 3494 indicate a frame or drive unit where the IBM 3590 Tape Control Unit is installed, for example, the IBM 3590 model A14 frame and the IBM 3494 model D14 drive unit.

IBM 3590 Control Unit



- Two ESCON channels
 - ◆ 17MB/s
 - ◆ Maximum 43 km
- 128 logical paths
- Both paths to each drive
- Single 3590 model (A00)
 - ◆ In free-standing frame (IBM 3590-A14)
 - ◆ In IBM 3494-D14 or L14
- Up to four IBM 3590 drives attached
 - ◆ Four within frame

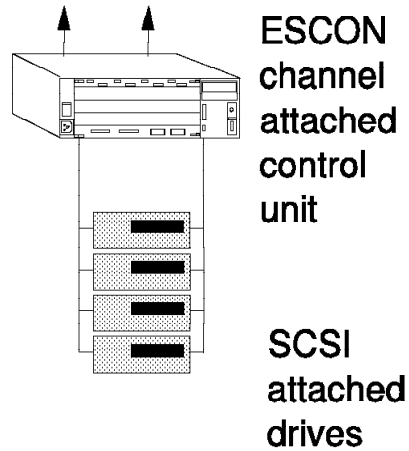

© IBM Corporation 1995

04/06/95

C35A01

NTPGCH2.PRS

Figure 17. IBM 3590 Control Unit

2.4 IBM 3590 Control Unit

The IBM 3590 model A00 tape control unit allows the IBM 3590 tape drive (which is a native SCSI device) to be attached to ESCON channels. The IBM 3590-A00 is not free-standing but is designed to fit into the purpose-built IBM 3590-A14 rack (the frame) or inside the IBM 3494 Automated Tape Library Dataserver.

- **One/Two ESCON channels**

Many of the functions of previous IBM tape control units have been moved into each IBM 3590 tape drive unit (see 2.2, "Magstar Tape Drive Schematic Comparison" on page 27). Thus the primary function of the IBM 3590-A00 is to provide an interface from the SCSI adapters on the IBM 3590 to the ES/9000 or S/390 ESCON channels. To achieve this the IBM 3590-A00 has one single-adapter ESCON card that provides attachment for one ESCON host channel and the IBM 3590 SCSI drive units. A single ESCON adapter is now available, soon after General Availability (GA) a second ESCON adapter will be available to improve the availability of the IBM 3590 subsystem. The IBM 3590-A00 is also attached to the Library Manager when installed in an IBM 3494 or 3495 configuration.

Note: The IBM 3590 High Performance Tape Subsystem do not support attachment to OEMI (parallel) channels.

- 17 MB/s

The IBM 3590-A00 supports the maximum speed, 17 MB/s, of the ES/9000 or S/390 Parallel Server ESCON channels. Together with IBMLZ1 compression and the improved IBM 3590 drive data transfer rate of 9

MB/s, this speed could considerably improve performance for long sustained tape I/Os, over the tape devices that support up to 9 MB/s channel speeds.

- Maximum 43 km

The maximum distance between the ES/9000 or S/390 host and the tape subsystem attached using the IBM 3590-A00 is 43 km.

- **128 logical paths**

The number of logical paths for each physical path has been quadrupled, from 16 to 64: a total of 128 logical paths is available with an IBM 3590-A00.

- **Both paths to each drive**

Both physical paths to the ES/9000 or S/390 host are available to each of the tape devices. This availability is the same as in the IBM 3490-A20 tape controller, which has two concurrently active paths to a single host. All attached tape devices in the subsystem can use both paths.

- **IBM 3590 model A00**

A single model of the IBM 3590 tape control unit fits into the two basic environments, the library and the frame. The latter is described in 2.5, “IBM 3590 Frame” on page 32. The frame and library environment are explained in more detail in Chapter 4, “Configuration Guidance” on page 65

The IBM 3590-A00 should be ordered separately for installation in either in the purpose-built rack IBM 3590-A00 or in the IBM 3494 Automated Tape Library Dataserver. All the components of a subsystem to be installed in an IBM 3494 or in an IBM 3590-A14 must be ordered separately.

- **Up to four IBM 3590 tape drives attached**

An IBM 3590-A00 can attach up to four IBM 3590-B11s in an IBM 3590-A14 or, four IBM 3590-B1As in an IBM 3590-A14 (IBM 3495 attach) or, four IBM 3590-B1As in a drive frame (IBM 3494-D14) of the IBM 3494 Automated Tape Library Dataserver. In the case of an IBM 3494-L14, the control unit frame can contain up to two IBM 3590-B1As attached to an IBM 3590-A00.

Unlike the 3480, 3490, and 3490E, tape control operations such as forward space file, back space file, and locate record do not tie up control unit function. These operations are controlled by the drive itself, and the control unit function in the IBM 3590-A00 becomes free. In the case of an IBM 3590-A00 with four IBM 3590-B11s or -B1As, a maximum of two data transfer operations and two tape control operations can occur at the same time.

IBM 3590 A14 Frame



- IBM 3590-A14 frame
- Purpose-built rack
- One IBM 3590-A00
 - Control unit
- Up to four IBM 3590-B11/B1As
 - Drives with ACFs
 - Always four drives when in IBM 3495

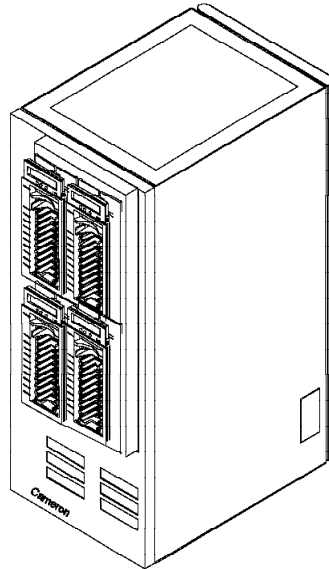

© IBM Corporation 1995

08/21/98

C35A02

NTPQCH2.PRS

Figure 18. IBM 3590 Frame

2.5 IBM 3590 Frame

This unit is the IBM 3590 model A14, a purpose-built rack that houses an IBM 3590 tape control unit and up to four IBM 3590-B11 drives with ACFs, or four IBM 3590-B1A's (NON ACF). An IBM 3590-A00 and up to four IBM 3590-B11s should be ordered separately for installation in an IBM 3590-A14.

This subsystem is similar to the IBM 3490 A and B models. It is this frame model that will be incorporated into the IBM 3495 Automated Tape Library Dataserver as part of the library configuration. When the IBM 3590-A14 is incorporated into the IBM 3495 Automated Tape Library Dataserver, the IBM 3590-A14 must have one IBM 3590-A00 and all four IBM 3590-B1As installed. The Library Manager of the IBM 3495 Automated Tape Library Dataserver supports attachment of up to eight control units (that is, IBM 3490 A-models or IBM 3590-A00s). Thus a maximum of eight IBM 3590-A14s (32 IBM 3590-B1A tape drives) can be incorporated into an IBM 3495 Automated Tape Library Dataserver configuration. The physical positions of the IBM 3590-A14 in an IBM 3495 Automated Tape Library Dataserver configuration are the same as the positions where the IBM 3490 B-models are installed today.

See Figure 33 on page 69 in section 4.2, "IBM 3495 Configurations" on the relationship between IBM 3495 models and the number of IBM 3590-A00s.

Note: The IBM 3590 High Performance Tape Subsystem is not supported in The IBM 3495 model M10 Manual Tape Library Dataserver.

An optional top-mounted operator display that connects directly to the IBM 3590-A14 has been designed by Texas Digital Systems, Inc. (TDS). The TDS 3590 Display Station features an eleven color LED display that can be read up to 90 feet, and provides flexible user controlled display functions that are menu selected via an infrared keyboard.

IBM 3590 Environmentals

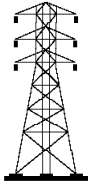

- Any voltage
 - 100-240 V ac
 - 50-60 Hz



- Class B device
 - 16-32 C
 - 1024 BTU/hr

DEVICE	DEPTH (mm)	HEIGHT (mm)	WIDTH (mm)	EIA Units	WEIGHT (Kg)
IBM 3590-A00	628	217	444	5	23.6
IBM 3590-A14	*1099(+85)	1800	724	N/A	227.0
IBM 3590-B11 (first and third)	988	522	230	12	49.5
IBM 3590-B11 (second and fourth)	988	522	230	12	40.5
IBM 3590-B1A	750	262	221	6	28.6

* Add 85mm for ACF of the model B11



© IBM Corporation 1995

04/10/95

ENVIR

NTPGCH2.PRS

Figure 19. IBM 3590 Environmentals

2.6 IBM 3590 Environmentals

- **Power control**

Power control is provided by a power on and off switch at the back of the device. A power-on indicator is located at the back of the drive near the switch.

AC power is supplied from a wall outlet, rack enclosure, or other AC source. The device is supplied with a single AC to DC power supply and will support a single IBM 3590 tape drive with ACF.

The IBM 3590 drive unit itself does not provide remote power control. If required, remote power control is provided by the enclosure or higher level subassembly.

- **Input voltages**

The IBM 3590 is designed to accept a wide variety of input voltages and frequencies; from 100 V AC (nominal) to 240 V AC (nominal) and from 50 Hz (nominal) to 60 Hz (nominal). The device will automatically adjust itself for proper operation when presented with any combination of these voltages and frequencies.

- **Power consumption**

The power consumption of each IBM 3590 with ACF is 0.3 kVA.

- **Cooling requirements**

The calorific value for an IBM 3590-B1A, IBM 3590-B11, and IBM 3590-A00 is 1024 BTU/hr. The value for an IBM 3590-A14 is 341 BTU/hr.

Cooling is provided by three fans. Two fans provide cooling to the tape deck and power supply. A third fan provides cooling to the card cage.

Thermal protection is provided by two sensors. Each sensor, when activated (by extremes of temperature outside recommended operating conditions), causes an immediate power down of the device. Once activated the sensor will not allow a device power-on until an IBM service representative resets the device. Only qualified personnel can reset the thermal sensor.

IBM 3590 High Performance Tape Cartridge

- 10GB uncompact data
- Same external dimensions as 3480 and 3490 cartridges
- No interchange with 3480 and 3490 drives
- Approx. same length as ECCST
- Linear serpentine recording
- New colored inserts identify cartridge type
- New handling indentations
- Media type indicator "J"
- Servo tracks

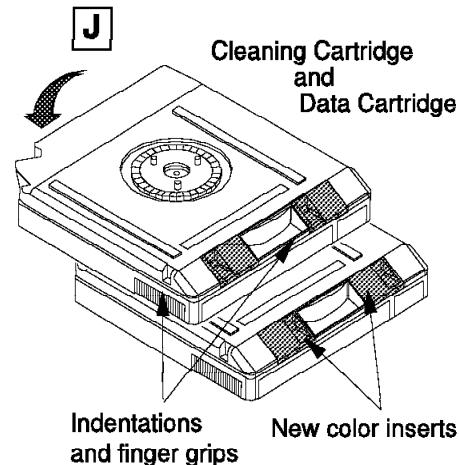

© IBM Corporation 1995

04/06/95

CNEWCRT

NTPGCH2.PRS

Figure 20. IBM 3590 High Performance Tape Cartridge

2.7 IBM 3590 High Performance Tape Cartridge

The tape cartridge and media used with the IBM 3590 tape drive—the IBM 3590 High Performance Tape Cartridge—is completely new; it is not compatible with any other IBM tape subsystems. You cannot read from or write to this tape using IBM 3480, 3490, or 3490E tape subsystems. (Note that the IBM 3590 tape drive can neither read from nor write to previous IBM tape cartridge formats—that is, neither 18-track nor 36-track format.)

• Characteristics

Physically the new tape cartridge is similar to the IBM 3480 cartridge design (the ECCST and CST (cartridge system tape))—that is, it has the same external size and shape. However, the IBM 3590 High Performance Tape Cartridge has a capacity of 10 GB (with uncompact data) or greater if the data is suitable for compaction.

The tape itself is a half inch wide and 300 m long, which is similar to the 320 m IBM 3490E ECCST. Thus the time in which to access the data, high speed searches, and rewind activity will be little changed from the current ECCST despite the considerable increase in capacity.

• Cartridge design

The cartridge casing is more robust than its predecessors but is otherwise the same physical size and shape as the IBM 3480 cartridge. It is also physically compatible with the IBM 3480 cartridge in terms of, for example, robotics handling and storage. However, some minor (but important)

differences physically distinguish the IBM 3590 cartridge from other cartridge types.

There are two new colored plastic inserts in the cartridge casing, and each insert has the potential for two indentations. The presence or absence of the indentations signifies a binary 1 or 0, and thus different cartridge types may be identified by the tape subsystem hardware. By this means it is possible to recognize 16 cartridge types. Currently, three cartridge types are recognized: the new IBM 3590 High Performance Tape Cartridge, the new IBM 3590 cleaner cartridge (these two cartridges are shown in Figure 20 on page 36), and the current IBM 3480 and 3490 cartridge. The absence of the inserts (and therefore no indentations) indicates a standard cartridge system tape (CST) or an ECCST (IBM 3480 and 3490 cartridge). The IBM 3590 hardware can recognize and reject this type of cartridge.

Note: This is a means for the hardware to recognize what sort of tape is mounted in the drive. This information is not passed to the host software or the Library Manager.

The leader block on the IBM 3590 High Performance Tape Cartridge has been modified such that it cannot be mounted in an IBM 3480, 3490, or 3490E drive. If an attempt is made to mount the IBM 3590 High Performance Tape Cartridge in an IBM 3480, 3490, or 3490E tape drive, the mount will be rejected. The IBM 3590 tape drive recognizes a standard IBM 3490E cartridge CST or an ECCST by the absence of the inserts as described above and rejects the mount.

The casing has been modified so that an operator can easily grasp a cartridge in the new cartridge magazine (see Section 3.4, “ACF Magazine” on page 46 for details on the new cartridge magazine). A large indentation between the blue inserts on the lower surface allows more space for the fingers to grip the cartridge, and a serrated surface at each side toward the back of the cartridge allows for secure handling if the cartridge is held in the other orientation.

- **Media type indicator “J”**

The new cartridges have a media type identifier, *J*, on the tape barcode label. The IBM Library Manager software uses this information to manage the different types of media in the library.

The designated character for the standard cartridge tape media type is *1*, and that for the ECCST is an *E*.

The IBM 3495 and the IBM 3494 will attempt to read the media type identifier to identify a type of cartridge. For compatibility with the current IBM 3495 implementation, if the IBM 3590 does not detect a media type barcode label, it attempts to determine whether the cartridge is either a CST or ECCST by means of the two-tone casing of the latter.

- **Metal particle medium**

A new metal particle medium is used in the IBM 3590 High Performance Tape Cartridge. The new medium has a much higher coercivity, which is required to support a high aerial density, and hence gives the ability to write a large a number of tracks. See Section 1.6, “Metal Particle Medium” on page 13 for more details about this medium.

The cartridge medium for the drives is manufactured to IBM specifications by 3M Corporation, which also produces magnetic media for IBM’s current halfinch tape cartridge. The cartridge with the new medium, is the result of

a codevelopment effort of IBM and 3M Corporation and incorporates the new particle tape formulated for higher capacity, performance, and reliability.

- **Servo tracks**

Each IBM 3590 High Performance Tape Cartridge has prerecorded servo tracks. The servo tracks on the tape cartridge are recorded at the time of manufacture. These tracks enable the IBM 3590 tape drive to position the read/write head accurately with respect to the media while the tape is in motion. If these servo tracks are damaged or removed, the cartridge cannot be written to until the servo tracks are restored. Degaussing an IBM 3590 cartridge requires use of a special metal particle degausser. After the tape has been degaussed, it should be returned to the manufacturer for reformatting of the servo tracks.

Chapter 3. IBM 3590 Automatic Cartridge Facility Operations

This chapter describes the IBM 3590 ACF. It is similar to the IBM 3480 ACL and IBM 3490 integrated cartridge loader (ICL).

The ACF has five modes of operation. This chapter describes the function and use of each mode.

Automatic Cartridge Facility (ACF)

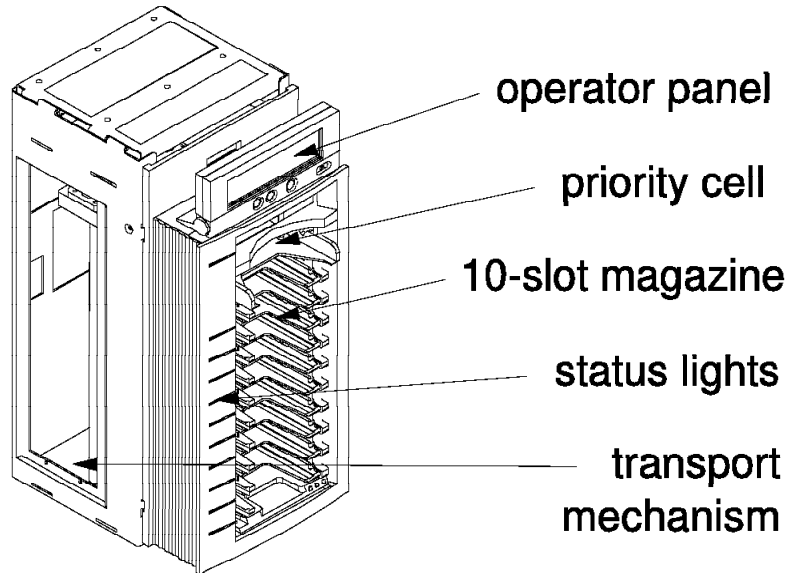

© IBM Corporation 1995

CACF01

04/08/95

NTPGCH3.PRS

Figure 21. Automatic Cartridge Facility

3.1 Automatic Cartridge Facility

The IBM 3590 ACF is designed to provide new functions while offering the same operational capabilities as the IBM 3490 ICL. It is a significantly different design; however, operators familiar with the IBM 3490 ICL will be able to quickly adapt to the new ACF.

3.1.1 Operator Panel

Mounted on the ACF housing is a liquid crystal display (LCD) panel and controls, which the operator can tilt for the optimum viewing angle. The display panel can also be removed from the front by IBM customer service representatives for rear service of the drive unit.

3.1.2 Priority Cell

In addition to the ten cartridge positions (cells), there is an eleventh slot known as the priority cell directly in front of the drive, at the top of the ACF. Specific mounts can be inserted in this slot without affecting the cartridges in the ACF magazine.

3.1.3 Ten-slot Magazine

The ACF has been expanded to hold up to ten cartridges. The cartridges are loaded into a convenient magazine, which is inserted into the cartridge loader as shown in Figure 21. A cartridge magazine is required to use the ACF.

3.1.4 Status Lights

Each of the ten magazine cells and the priority cell is equipped with a bicolored LED (yellow and green) cell status indicator. The operator can thus determine some machine conditions from some distance away before checking the operator panel for check codes and text messages.

One or more flashing yellow cell indicator lights signify attention conditions, indicating that a device cannot continue to function without operator intervention. Various positions and numbers of lights are associated with different types of attention conditions. For example, if 1 of the 11 cell lights is flashing, it can indicate a cell conflict—that is, a cartridge cannot be unloaded to its assigned cell because the sensors indicate that the cell is already occupied. If the priority cell light is flashing, it may indicate an unfulfilled mount request. If all cell lights are flashing, there may be a cartridge jam in either the ACF (10 lights flash) or the drive (all 11 lights flash).

Alert conditions are a somewhat lower priority and are indicated by steady-state yellow lights. These lights indicate that a condition exists that does not immediately preclude the use of the drive. For example, if the priority cell indicator is steady yellow, a cartridge may need to be removed from the priority cell. If all ten magazine lights are lit steady yellow, the magazine is either not installed or it is empty, or it is full of used cartridges that need to be removed or replaced. The green lights indicate that there is some activity with the cartridge that normally resides in that cell. If a cartridge is placed in such a cell, a cell conflict condition will ultimately result.

3.1.5 Transport Mechanism

Transport mechanisms within the ACF move the cartridges between drive, magazine, and the priority cell.

When a mount is requested, the cartridge is moved (imported) from the magazine into the ACF where it is elevated to the mouth of the drive and then mounted. The elevation of a cartridge from the lowest position in the magazine to the drive takes approximately 2 seconds. When the tape is unloaded and demounted, the elevator returns (exports) the cartridge to the same slot in the magazine.

IBM 3590 Operator Panel

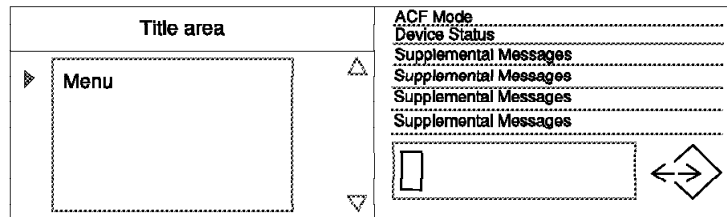
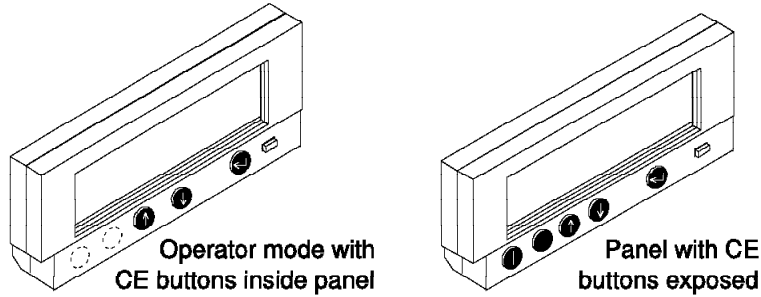

IBM Corporation 1995
01/31/95

OPANEL1
NTPG.PRS

Figure 22. IBM 3590 Operator Panel

3.2 IBM 3590 Operator Panel

The IBM 3590 operator panel displays menus, device status, activities, error conditions, and messages. It is typically plugged into a socket located on the front of the drive, or on the ACF if installed. For rear service environments, the operator panel can be removed from the front and plugged in the back so that a hardware service representative working at the rear of the device can easily view it.

The operator panel has five switches that are used to select functions located on the panel mounting socket. Two of the switches are for IBM service representative personnel use, and these are hidden from view and protected from operator access when in normal operation:

- Reset switch (hidden)

This button is marked with a vertical bar and in normal operation is hidden from view. It is enabled at all times and, when pressed, causes a device power-on reset.

- Mode switch (hidden)

This button is marked with a symbol of a wrench and in normal operation is hidden from view. It is a toggle switch that selects either CE mode or normal mode. The CE mode enables special menus for service activities not available in normal mode. CE mode can be selected at any time, but it will not become active until the device completes the current processes. Normal

mode can be selected at any time. The layout of the display is shown in the diagram.

- Menu control switches (in view)

The three menu control switches are used to select and control the choices currently displayed on the panel. The two switches marked with up and down arrows move the cursor up and down the menu items; the third switch, marked with a return key symbol, is used to enter the selection.

There is one power on and off switch for each IBM 3590. It is located at the back of the device and controls the distribution of AC power to the device.

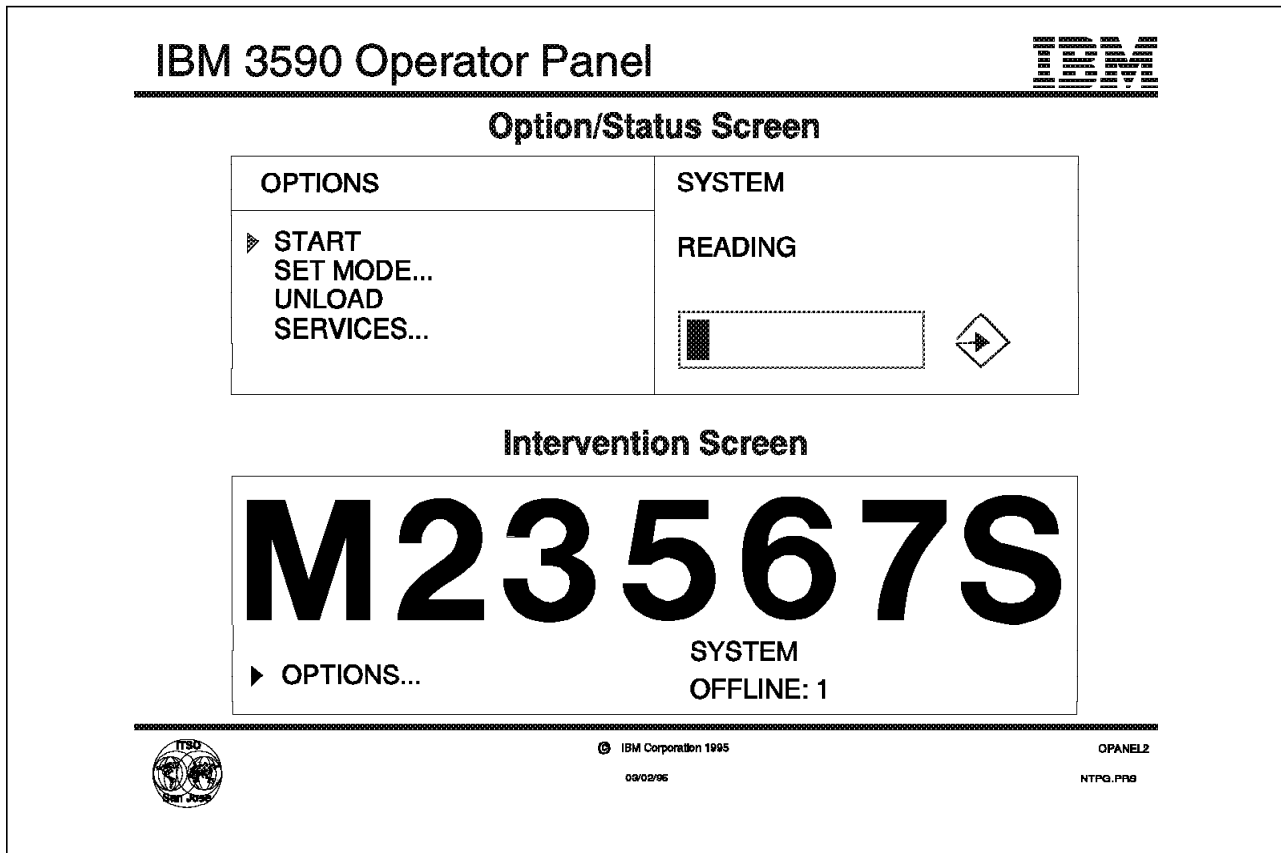

Figure 23. IBM 3590 Operator Panel Screens

3.3 IBM 3590 Operator Panel Screens

Two screens are displayed on the IBM 3590 Operator Panel: the Option/Status Screen and the Intervention Screen. The Option/Status Screen is the default screen. It consists of a menu area and a status area.

- **Menu area lists various control functions**

Note: For the IBM 3590, UNLOAD is a menu selection. When you select the UNLOAD option, a loaded cartridge is rewound and unloaded from the device. The device does not accept any motion commands after UNLOAD has been selected. If the device has data in the buffers, it will synchronize the data before rewinding. If it is unable to synchronize the buffers, an appropriate error will be presented to the host. The device will be in Not Ready status immediately after UNLOAD is selected.

- **Status area shows:**

- ACF mode status (SYSTEM in the example)
- Offline mode status (the device is not offline in the example)
- Current device activity (READING in the example; other possibilities are cleaning, ready, unloading, rewinding, writing, ACF disabled, and so on)
- Supplemental messages (none in the example)
- The tape position indicator, which provides the operator with a graphical representation of the position of the device relative to the beginning and

end-of-volume (if processing) or the beginning and end of the medium (if rewinding).

- Status icons (show the direction of movement of the tape in the example).

The Intervention Screen overlays the default screen when human intervention is required. It consists of a single eight-character intervention message displayed in large font, a prompt indicating that the options menu can be accessed by pressing Enter, device status information, and a two-line message area (in standard font).

There are five types of messages:

- Routine messages that is, messages received from the host (for example, mount and demount messages) and the CLEAN message. In general, routine messages are intended to refer to the priority cell.
- Check messages, which indicate error conditions that customer personnel may be able to resolve.
- FID (field replaceable unit (FRU) identification) messages of varying degrees of severity

An FID 1 message is generated when a hardware failure has occurred. The message numbers should be reported to the service representative when a repair call is made. A corresponding service information message (SIM) will be sent to the host operating system.

An FID 2 message indicates that the drive is in a degraded state but can still be used.

An FID 3 message indicates that some service circuitry has failed.

ACF Magazine

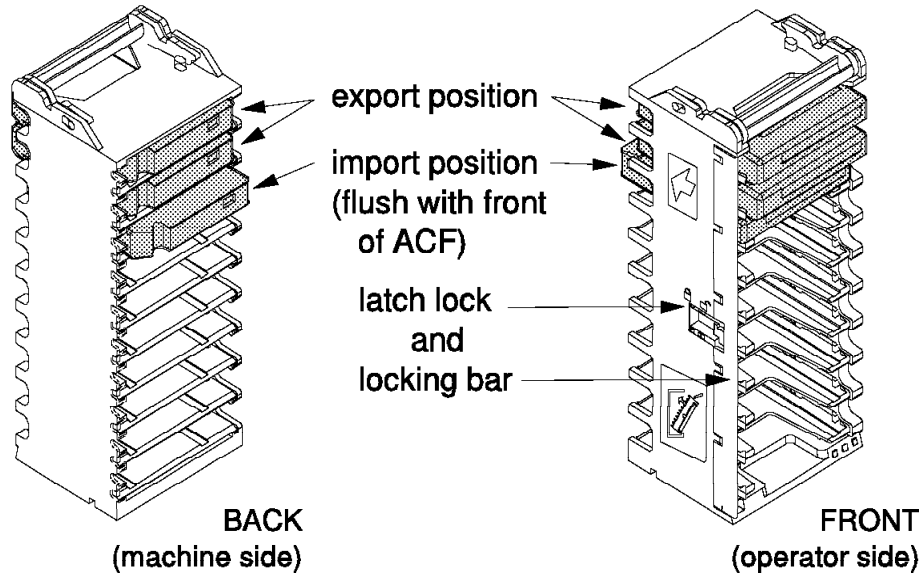

© IBM Corporation 1995
01/31/95

CACFMAG
NTPG.PRS

Figure 24. ACF Magazine

3.4 ACF Magazine

The cartridge magazine slots into the ACF. It may be loaded with up to ten cartridges and transported using the carrying handle.

3.4.1 Export Position

When a cartridge is returned to its cell after it has been processed, it is pushed out of the cell slightly (about 16 mm) to facilitate cartridge removal. An operator can easily see which cartridges have been processed and may be removed or replaced.

Note: when in random mode the ACF operates slightly differently (see Section 3.10, "ACF Random Mode" on page 59).

3.4.2 Import Position

When the operator inserts a new cartridge into the ACF magazine, the cartridge is in the import position; the outside edge of the cartridge appears flush with the edge of the magazine.

3.4.3 Magazine Locking

To ensure the physical security of the cartridges during handling as well as data security, two locking mechanisms hold the cartridges in the magazine:

- **Latch lock**

A detent mechanism is designed into the magazine such that when the magazine is removed from the ACF, each cartridge is held in whatever position (import or export) it happens to be in at the time of removal.⁴ With the magazine in the device, the detent mechanism can be released by the device, one cartridge at a time. The operator can freely remove or install cartridges at any time (unless the magazine is locked).

- **Locking bar**

A physical transport lock at the side of the magazine can be used to prevent the removal or insertion of cartridges by the operator until the whole magazine is removed and unlocked. This lock has a two-position latch mechanism:

- Normal position - where the locking bar is opened. Even in this position the cartridges (whether in import or export position) are prevented from falling out of the magazine while the magazine is being transported. However, the operator can easily remove and replace cartridges while the lock is in the normal position, for example, in automatic or system ACF modes.
- Locked position - where the locking bar is closed and locked in position. The operator cannot remove (or install) cartridges from the operator access side of the magazine. When the magazine is installed in the ACF, the operator cannot access the machine side of the magazine, nor can he or she access or change the position of the magazine lock without first removing the magazine from the ACF. (When the ACF magazine is thus removed, the host program or application is alerted.) A sensor in the device determines whether the latch is in the locked position.

⁴ A detent is a hinged or pivoted device that fits into a notch of another machine part to drive it forward or prevent backward motion.

ACF Modes of Operation

● MANUAL

- Operator initiates load
- Cartridge replaced in original cell

● ACCUMULATE

- Operator initiates load
- Cartridges returned to magazine cell

● AUTOMATIC

- ACF initiates load from next cell
- Cartridge replaced in original cell

● SYSTEM

- Host program initiates load from next cell
- Cartridge replaced in original cell

● RANDOM

- Host program controls load from any cell
- Host program controls return to any cell



© IBM Corporation 1995

08/21/98

CACFM0D

NTPGCH3.PRS

Figure 25. ACF Modes of Operation

3.5 ACF Modes of Operation

The ACF has five modes of operation: manual, accumulate, automatic, system, and random. Manual, automatic, and system modes are the same as the IBM 3490 ACL modes. Accumulate and random modes are new modes.

The operator can set the ACF mode (with the exception of library mode) or switch between modes; the physical switch on the drive has been replaced with an electronic switch that is accessed using the operator panel (see Section 3.2, "IBM 3590 Operator Panel" on page 42 for further details about the operator panel).

All ACF modes are hardware settings that determine how the ACF reacts to system requests.

The different modes are explained briefly below and in more detail in Sections 3.6, "ACF Manual Mode" on page 51 through Section 3.10, "ACF Random Mode" on page 59 .

• Manual

Manual mode allows either operator mounting of individual cartridges or operator-initiated mounting of a premounted cartridge. Manual mode may be set either by the operator, using the operator panel, or automatically when the magazine is full.

• Accumulate

Accumulate mode is similar to manual mode. The operator inserts individual cartridges into the priority cell, but the cartridge is not returned to the priority cell from which it was mounted. Instead, a processed cartridge is returned to the next available cell in the magazine. This mode facilitates the removal of cartridges by the operator.

- **Automatic**

In automatic mode cartridge loading is under the control of the ACF. The cartridges are accessed sequentially; the next unused cartridge is imported directly into the drive. Once the tape has finished processing, it is exported to its cell, and the next cartridge is imported to the drive. The cartridges are loaded even if a system mount is not issued.

If and when a nonspecific private volume (scratch) request is allocated to a drive in automatic mode, the premounted cartridge is used, whether or not it is an eligible scratch volume. (Note that in most installations some form of tape management system, such as DFSMSrmm, is used to protect against the use of ineligible volumes.)

If and when a specific volume request is allocated to a drive in automatic mode, and the volume is not premounted in the drive or in the magazine cells, each volume is imported and exported in turn, as the system searches for the specified volume.

- **System**

System is the recommended (and the default) mode for MVS operations.

In system mode the automatic mounting of cartridges is under the indirect control of the host programming software; that is, the program specifies that a cartridge is to be loaded if possible, but it cannot specify from which cell the cartridge is to be obtained.

Requests for automatic scratch mounts and manual specific mounts can be intermixed. If and when a nonspecific private volume (scratch) mount is requested, the next sequential volume from the magazine cells will be mounted; the volumes are not premounted in the drive. If and when a specific volume mount is requested, the volume is mounted by the operator using the priority cell.

- **Random**

In random mode the host programming software controls the ACF directly. The host software can move cartridges from the priority cell to any empty magazine cell or to the drive, and it can move any cartridge in the magazine or the drive to the priority cell.

The host software must use the SCSI Medium Mover commands or S/370 Stage channel command word (CCW) to select a cartridge from a given cell and move it to its destination cell. Control of the source and destination cell is left entirely to the host software.

In random mode the cartridges are locked in the magazine in the import position. The operator can insert specific mounts into the priority cell, which is addressed by the host software just like any other cell. In other words, when in random mode this cell has no inherent priority; it is used as an input/output cell for the magazine.

Note: This hardware capability is driven by the operating software, which must be capable of sending suitable commands to the subsystem. ***Magazine inventory and control are entirely the responsibility of the host software.*** The ACF hardware has no means of reading an external cartridge label to identify a tape to be mounted, nor does the tape subsystem microcode “remember” which tapes are present in the ACF in any way.

With BRMS/400, ADSM for OS/400, ADSM for AIX, and ADSM for SunOS/Solaris, users have the option of using random mode. With DFSMS/MVS, users can write their own code to use random mode, but ***DFSMS/MVS itself does not use random mode.***

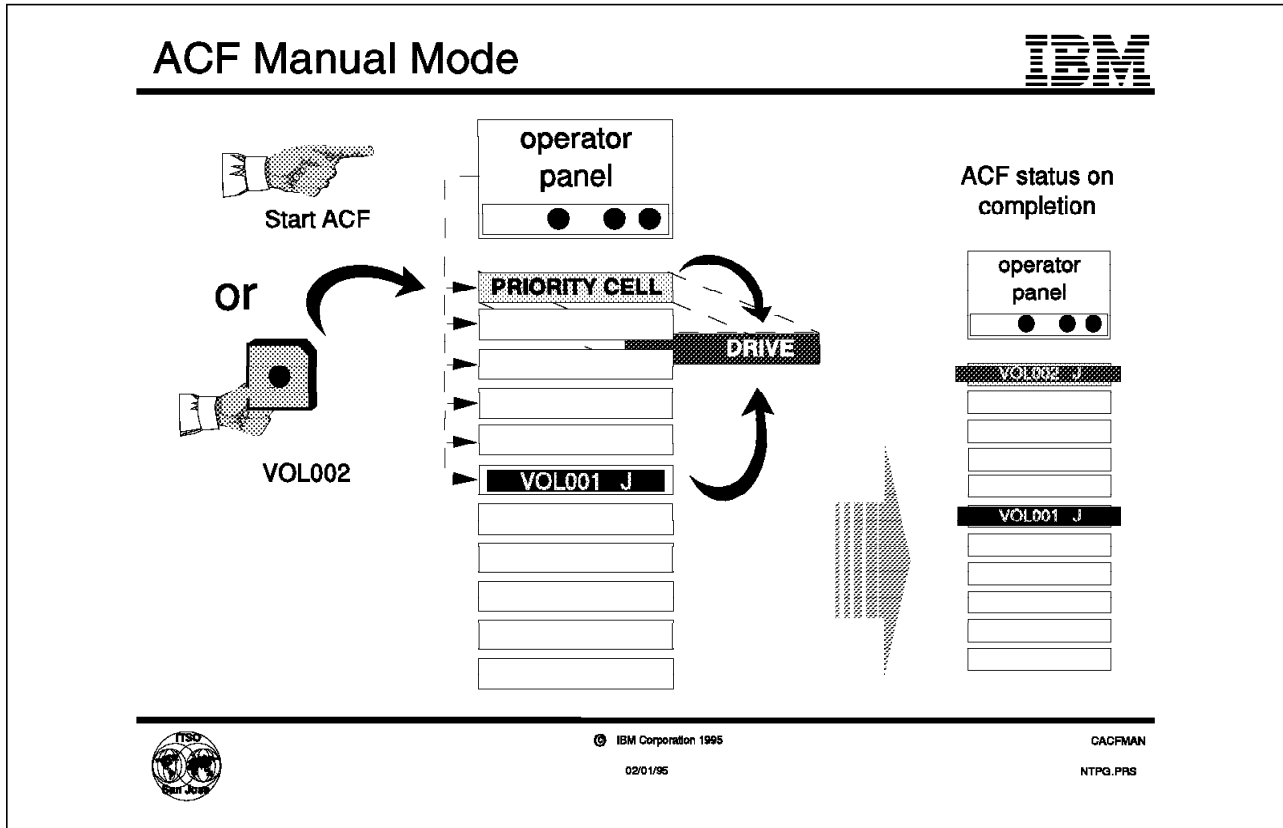

Figure 26. ACF Manual Mode

3.6 ACF Manual Mode

Manual mode allows the operator to load cartridges directly Figure 26. Once manual mode has been set (for example, from the operating panel), it can be enabled by selecting Start ACF on the operator's panel (see Figure 23 on page 44) or inserting a cartridge into the import position of the priority cell.

Once the single cartridge has finished processing, the mode will become disabled until the operator has loaded the next cartridge.

3.6.1 Operational Flow

Figure 26 shows the two ways in which an operator can mount a volume in manual mode:

1. If the operator selects Start ACF on the operator's panel, the ACF will become enabled and will verify that there is at least one cartridge in the import position of the magazine. If so, the ACF will index down the magazine until it finds the first cell with a cartridge in the import position (VOL001 in the diagram). The ACF will set the status indicator light for that cell to "in use" (which is a steady green light) and move the cartridge from the cell to the drive.
2. If the operator inserts a cartridge in the priority cell (VOL002 in the diagram), the ACF will load the cartridge into the drive and set the status indicator light for the priority cell to "in use" (steady green light).

3. If a cartridge is placed in the priority cell while the ACF is enabled (for example, processing a cartridge from a cell in the magazine), the ACF will activate the status indicator light for the priority cell to “in use” and, when the ACF has completed its current operation, it will automatically load the cartridge from the priority cell. Preloading the priority cell in this way may result in a cell conflict condition as described below.
4. When a cartridge that was loaded while in manual mode is unloaded, if possible, it is returned to its original cell, and the “in use” indicator light is turned off; the cartridge will be in the export position. If the original cell is occupied, the ACF will turn off the “in use” light, put the cartridge in the priority cell, and set the priority cell status light to “alert” (which is a steady yellow light). If the priority cell is already occupied, the priority cell status indicator is set to “attention” (which is a flashing yellow light) to indicate a cell conflict condition. The ACF will become disabled, and an intervention message will be posted.

3.6.2 Disabling Conditions

The ACF will become disabled in manual mode when:

- The magazine cartridge has been processed and returned to its original cell and there is no cartridge in the import position of the priority cell.
- The ACF is enabled by the operator by selecting Start ACF, but the ACF cannot detect a cartridge in the import position in the magazine.
- There is an “extra cartridge” condition or some similar condition that requires operator attention.
- Start ACF is entered on the operator panel, and the ACF cannot detect the presence of the magazine.

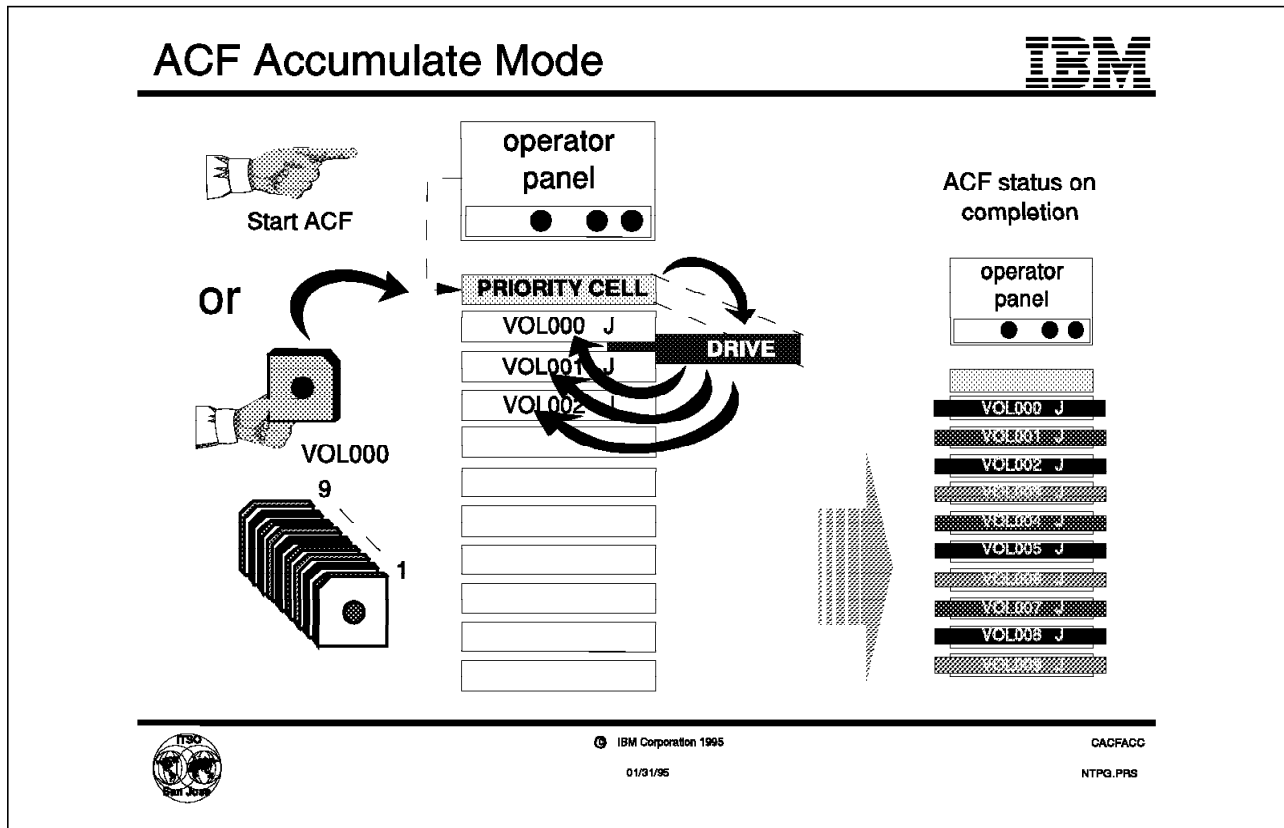

Figure 27. ACF Accumulate Mode

3.7 ACF Accumulate Mode

Accumulate mode Figure 27 works similarly to manual mode. The cartridges are not returned to their original cell after processing, however. They are always exported to a cell in the magazine and always imported from the priority cell. Although not a requirement, it is recommended that initially the magazine should be empty.

Once accumulate mode has been set (for example, from the operator panel), it can be enabled by selecting Start ACF on the operator's panel or inserting a cartridge into the import position of the priority cell

Once the magazine and priority cell are full of exported cartridges, the ACF will become disabled until the operator empties the magazine and re-enables the ACF.

3.7.1 Operational Flow

Figure 27 shows the two ways in which an operator can mount volumes in accumulate mode:

1. If the ACF is disabled and in accumulate mode, and the operator enters Start ACF on the operator panel, the ACF will become enabled and will wait until a cartridge is inserted in the import position of the priority cell.
2. When a cartridge is inserted into the priority cell, the priority cell status indicator light will change to "in use."

3. As soon as the drive is available, the cartridge will be loaded (VOL000 in the diagram), and the status indicator light will be turned off. The cartridge will not be returned to the priority cell, and the priority cell is now ready to accept another cartridge (VOL001 in the diagram). When in accumulate mode, all magazine cell status lights are set to "in use" to remind the operator that the entire magazine is reserved to accumulate processed cartridges and that he or she should insert cartridges only in the priority cell.
4. When a cartridge is unloaded from the drive, it is moved to the magazine. The ACF places the cartridge in the top cell of the magazine unless that cell is occupied, in which case the ACF searches down the magazine for the next available cell. Each cartridge is placed in the export position.
5. When the magazine has its last available cell filled, all cell magazine status indicator lights are set to "alert" (the steady yellow light) to warn the operator to unload the magazine. When the next cartridge is unloaded it is placed in the priority cell, if possible, and the priority cell indicator is also set to "alert."

3.7.2 Disabling Conditions

The ACF will become disabled in accumulate mode when:

- The magazine has been filled and the last imported cartridge returned to the priority cell
- There is an "extra cartridge" condition or some similar condition that requires operator attention.
- Start ACF is entered on operator panel, and the ACF cannot detect the presence of the magazine.

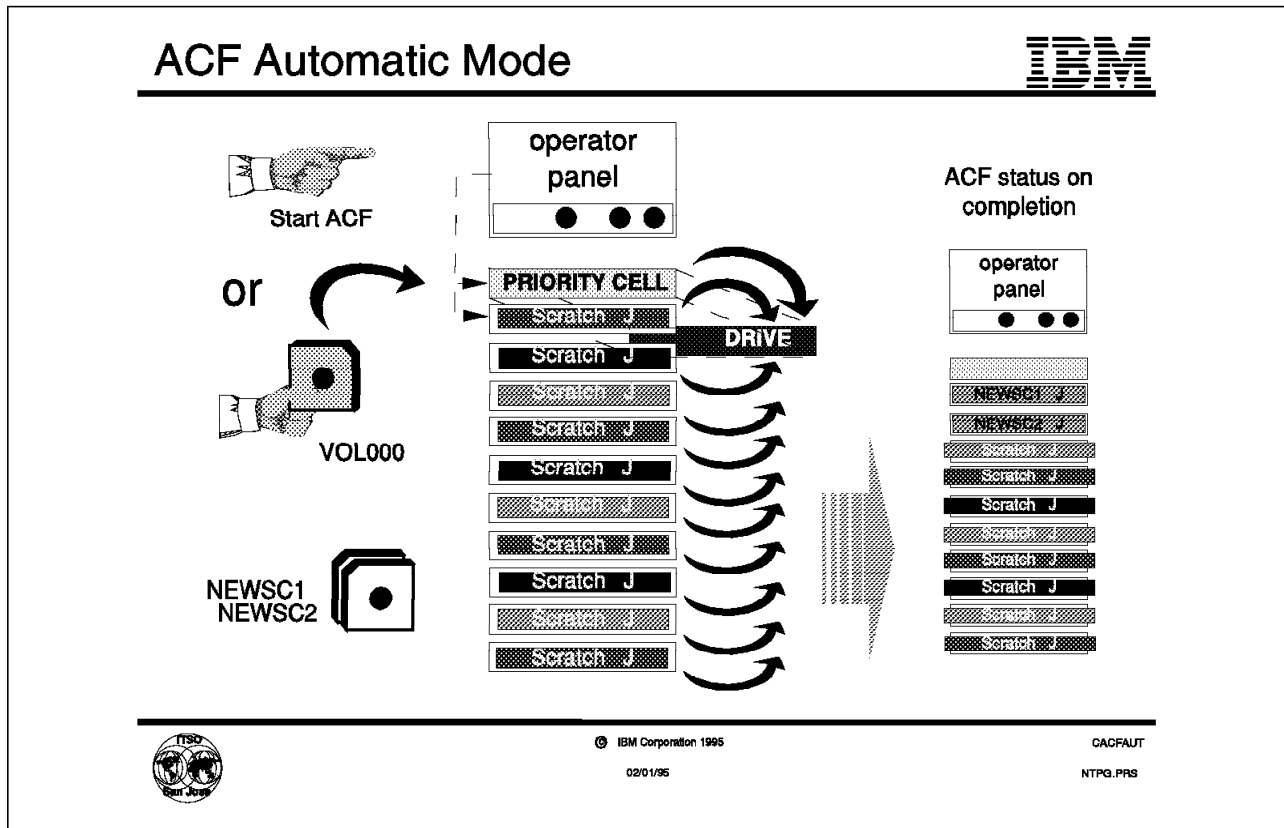

Figure 28. ACF Automatic Mode

3.8 ACF Automatic Mode

Automatic mode Figure 28 allows the operator to keep the drive continually fed with cartridges from the magazine. After the ACF is enabled, it automatically feeds cartridges to the device until all of the cartridges in the magazine have been processed. Processed cartridges are returned to their originating cell in the export position and can be removed from the magazine (and unprocessed cartridges can be added) without disturbing the ACF; the ACF will find each unprocessed cartridge in turn.

The operator can supply specific cartridges for an application by simply inserting the cartridge into the priority cell. When a specific mount is requested and a scratch cartridge is already mounted, it will be identified as the incorrect volume serial and “flushed” from the drive; the cartridge in the priority cell will automatically be the next one to be loaded into the drive. When the specific cartridge has been processed, the ACF automatically resumes processing cartridges from the magazine.

Once automatic mode has been set (for example, from the operator panel), it can be enabled by selecting Start ACF on the operator’s panel or inserting a cartridge into the import position of the priority cell.

Automatic mode is usually enabled through the operator panel. The ACF then loads the first cartridge directly to the device before receiving a mount request from the initiator. Although not a requirement, the magazine would normally be full when the mode is first enabled.

If the magazine and priority cell are allowed to become full of exported cartridges, the ACF will become disabled until the operator empties the magazine and re-enables the ACF.

3.8.1 Operational Flow

Figure 28 on page 55 shows how the operator enables the ACF and how the ACF progressively processes each volume in turn from the magazine:

1. If the operator selects Start ACF on the operator's panel, the ACF will become enabled and will verify that there is at least one cartridge in the import position of the magazine. If so, the ACF will index down the magazine until it finds the first cell with a cartridge in the import position (a scratch cartridge in the diagram). The ACF will set the status indicator light for that cell to "in use" (which is a steady green light) and move the cartridge from the cell to the drive.
2. If the operator inserts a cartridge in the priority cell (VOL000 in the diagram), the ACF will be enabled and load the cartridge into the drive and set the status indicator light for the priority cell to "in use."
3. If a cartridge is placed in the priority cell while the ACF is enabled, the ACF will activate the status indicator light for the priority cell to "in use," and when the ACF has completed its current operation, the ACF will automatically load the cartridge from the priority cell.
4. When a cartridge that was loaded while in automatic mode is unloaded, if possible, it is returned to its original cell, and the "in use" indicator light is turned off. The cartridge will be in the export position. The ACF then searches the magazine for the next cell in the import position and loads it to the device. This process is repeated until the ACF cannot find another loadable cartridge. At the end of the process shown in the diagram, the operator has removed the first two processed scratch volumes and replaced them with the new volumes, NEWSC1 and NEWSC2, in the import position. The other scratch volumes have been processed and are in the export position (they are now private volumes).

3.8.2 Disabling Conditions

The ACF will become disabled in automatic mode when:

- A cartridge has been processed and returned to its original cell and there is no cartridge in the import position in the magazine or the priority cell.
- The ACF is enabled by the operator selecting Start ACF, but the ACF cannot detect a cartridge in the import position in the magazine or the priority cell.
- There is an "extra cartridge" condition or some similar condition that requires operator attention.

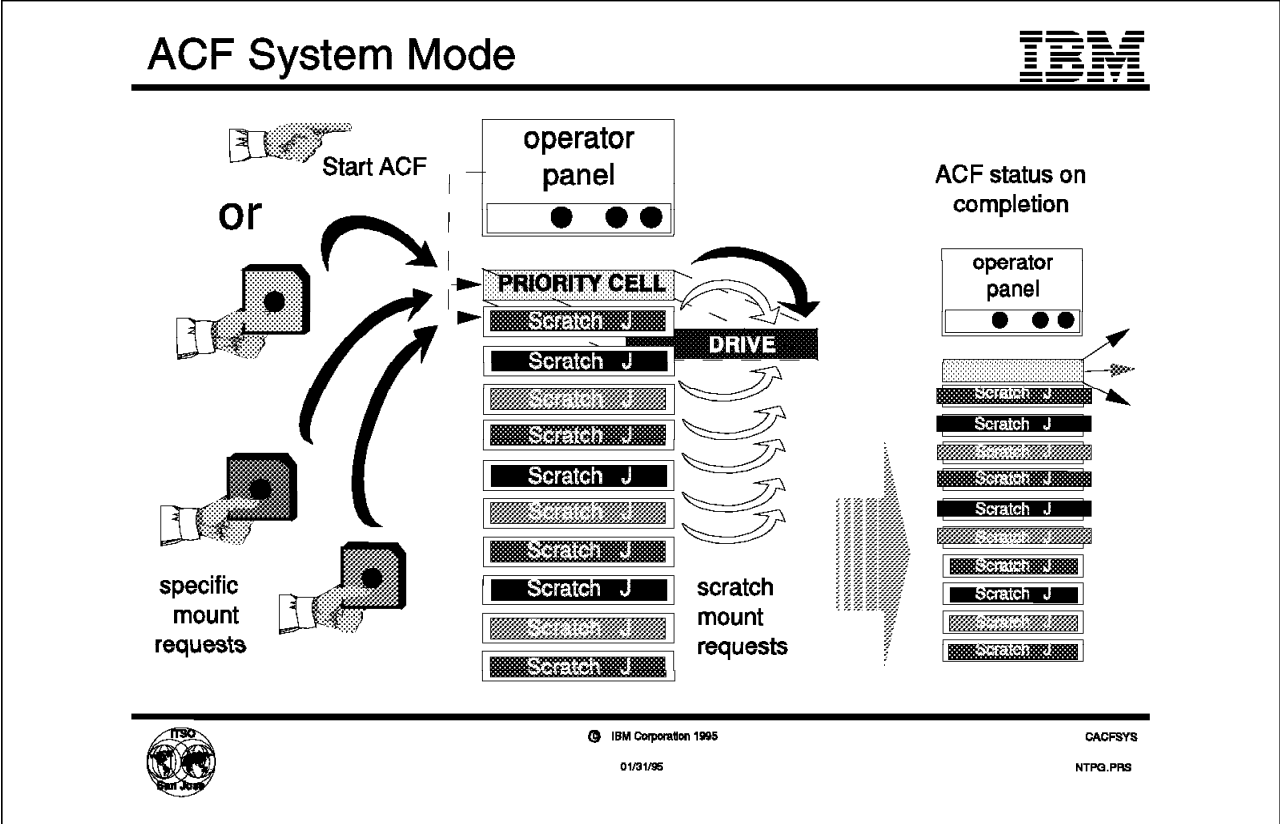

Figure 29. ACF System Mode

3.9 ACF System Mode

System mode Figure 29 also allows the operator to keep the drive continually fed with cartridges from the magazine. After the ACF is enabled (which loads the first cartridge), all subsequent load commands are under the control of the host operating software. The ACF will load one cartridge in response to each system command until all of the cartridges in the magazine have been processed. Processed cartridges are returned to their originating cell in the export position and can be removed from the magazine (and unprocessed cartridges can be added) without disturbing the ACF. The ACF will find each unprocessed cartridge in turn.

System mode does not preclude specific mount requests from the host software. The operator can supply specific cartridges for an application by inserting the cartridge into the priority cell. The cartridge in the priority cell will automatically be the next one to be loaded into the drive. When the specific cartridge has been processed, the ACF will automatically resume processing cartridges from the magazine, when the host software requests the next load.

Once system mode has been set (for example, from the operator panel) it can be enabled by selecting Start ACF on the operator's panel or inserting a cartridge into the import position of the priority cell.

3.9.1 Operational Flow

Figure 29 on page 57 shows how the operator enables the ACF and how the ACF is ready to sequentially process the scratch cartridges from the magazine:

1. If the operator selects Start ACF on the operator's panel, the ACF will become enabled and will verify that there is at least one cartridge in the import position of the magazine. If so, the ACF will index down the magazine until it finds the first cell with a cartridge in the import position. The ACF will set the status indicator light for that cell to "in use" (which is a steady green light) and move the first scratch cartridge from the cell to the drive.
2. If the operator inserts a cartridge in the priority cell (one of the specific mounts in the diagram), the ACF will be enabled and load the cartridge into the drive and set the status indicator light for the priority cell to "in use."
3. If a cartridge is placed in the priority cell while the ACF is enabled (the two specific mounts in the diagram), the ACF will activate the status indicator light for the priority cell to "in use." When the ACF has completed its current operation, it will automatically load the cartridge from the priority cell. These specific mounts are each removed from the priority cell after they have finished being processed.
4. When a cartridge that was loaded while in system mode is unloaded, if possible, it is returned to its original cell, and the "in use" indicator light is turned off; the cartridge will be in the export position. The ACF will wait, in the enabled state, until it receives the Load Unload command, or until a cartridge is inserted in the priority cell. In the case of the Load Unload command, the ACF will then search the magazine for the next cell with a cartridge in the import position and will load it into the device. This process will be repeated until the ACF cannot find another loadable cartridge. At the end of the process shown in the diagram, the operator has removed the three specific mounts from the priority cell; the first six scratch cartridges have been processed from the magazine and are in the export position ready for the operator to replace them. The last three scratch volumes have yet to be processed; there is no cartridge in the drive.

3.9.2 Disabling Conditions

The ACF will become disabled in system mode when:

- A cartridge has been processed and returned to its original cell and there is no cartridge in the import position in the magazine or the priority cell.
- The ACF is enabled by the operator selecting Start ACF, but the ACF cannot detect a cartridge in the import position in the magazine or the priority cell.
- There is an "extra cartridge" condition or some similar condition that requires operator attention.

ACF Random Mode

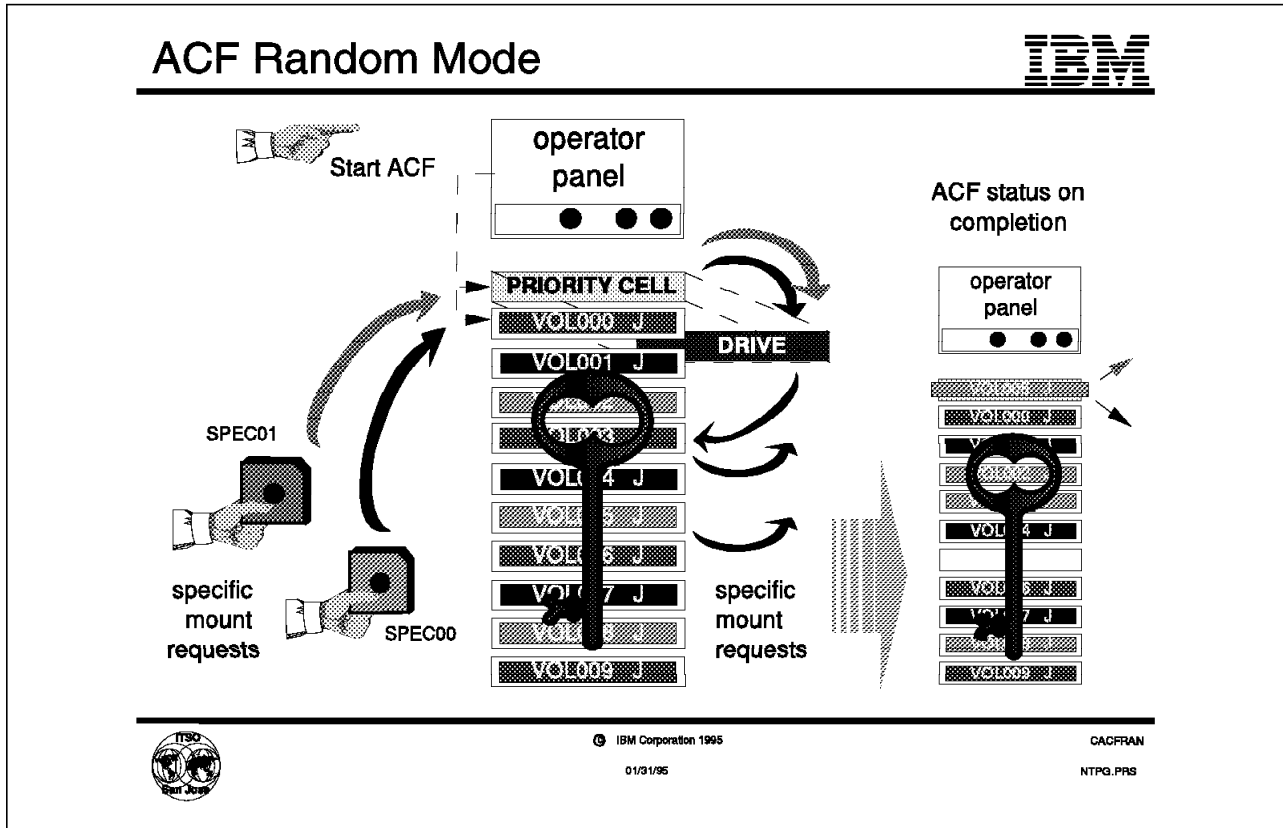

Figure 30. ACF Random Mode

3.10 ACF Random Mode

Random mode Figure 30 is designed to allow the IBM 3590 tape drive to act as a small, self-contained library of up to ten cartridges, controlled entirely by the host programming software. The host software uses the S/370 Stage CCW (channel command word) or SCSI Medium Mover commands (Prevent or Allow Medium Removal, Read Element Status, and Move Medium) to select a cartridge from a given cell and move it to its destination cell. Control of the source and destination cell is left entirely to the host software. The Medium Mover commands or Stage CCW provide the host software with information to assist in generating and maintaining an inventory of the cartridges in the magazine and to indicate to the operator that these cartridges may or may not be removed.

Note: BRMS/400, ADSM for OS/400, ADSM for AIX, and ADSM for SunOS/Solaris use random mode, but DFSMS/MVS does not use random mode.

Random mode does not preclude host requests for specific mounts, which may be inserted in the priority cell. However, in random mode, the priority cell is simply another addressable cell; the ACF notifies the host that there is a cartridge in the priority cell, but the host software must specifically address that cell to access the cartridge.

Note: The physical implementation for most of the modes can be viewed as a medium changer (the ACF), with 11 import and export cells (the magazine and priority cell), no storage elements, and a single medium transport element and data transfer element (the drive), which cannot be used to permanently store a piece of medium (a cartridge). Random mode, however, can be viewed as

having one import and export cell (the priority cell), ten storage elements (the magazine), and a single medium transport element and data transfer element (the drive).

To ensure the integrity of the magazine, it is equipped with a lock, which prevents the addition or removal of cartridges once it is locked and installed in the ACF. The state of the magazine lock is sensed by the ACF, which will not permit random mode to be enabled unless the magazine lock is set in the locked position. A sensor allows the unit to determine that the magazine has been removed, and if so random mode will be disabled. Because the magazine must be locked in random mode, the priority cell is used as an input/output port for the magazine. The host software can move cartridges from the priority cell to any empty cell in the magazine (or to the drive).

Once random mode has been set (for example, from the operator panel), it is enabled when the following three conditions are met:

- A magazine is installed in the ACF.
- The magazine lock is set in the locked state.
- Start ACF is selected on the operator's panel.

3.10.1 Operational Flow

Figure 30 on page 59 shows how the operator enables the ACF in random mode by selecting Start ACF on the operator panel. The ACF then waits for commands from the host programming software.

1. All cartridges in the magazine are locked in the import position. All of the magazine status lights are activated to "in use" and remain so unless random mode is disabled. The priority cell status light is activated as it is used.
2. The host software may request any of the volumes from any cell using the S/370 Stage CCW or SCSI Move Medium commands. The ACF will honor the SCSI Prevent/Allow Media Removal command by not allowing the operator-initiated export of cartridges any time the command has specified Prevent Media Removal. The S/370 Stage CCW can accomplish the same actions as the SCSI Medium Mover commands.
3. When a cartridge is unloaded in random mode, it may or may not be returned to the same cell from which it was loaded. The control of the cartridge location is entirely the concern of the host software. In the diagram, VOL003 is processed and then returned to the priority cell for removal by the operator (ejected from the magazine "library").
4. Volume SPEC01 is then placed in the priority cell; the host is made aware that there is a cartridge in the priority cell but it cannot process it immediately. It can process cartridges (VOLnnn) from other cells followed by SPEC01, returning all of these cartridges to their original cells. SPEC01 is removed by the operator and replaced by SPEC00, which is processed and then moved to a cell in the magazine.
5. Volume VOL005 is processed and then placed in the priority cell where it remains in the export position until removed by the operator.

3.10.2 Disabling Conditions

The ACF will become disabled in random mode when:

- The magazine is removed from the ACF.
- There is an “extra cartridge” condition in the priority cell or some similar condition that requires operator attention.

ACF Mode Enabling and Disabling



ACF MODE	Conditions to Set Mode			Magazine Status		
	Magazine Required?	Lock Set Required?	If Magazine Removed?	Loaded (all 10 carts in import)	Full (all 10 carts in export)	Empty (all 10 cells empty)
MANUAL	no	no	ENABLE	ENABLE	disable	disable
ACCUMULATE	YES	no	disable	disable	disable	ENABLE
AUTOMATIC	no	no	ENABLE	ENABLE	disable	disable
SYSTEM	no	no	ENABLE	disable	disable	disable
RANDOM	YES	YES	disable	ENABLE	N/A	ENABLE



© IBM Corporation 1995
08/21/98

CACFTAB
NTPGCH3.PRS

Figure 31. ACF Mode Enabling and Disabling

3.11 ACF Mode Enabling and Disabling

Figure 31 summarizes the requirements for enabling each mode. The following points cover all modes with regard to the conditions under which the ACF becomes disabled and enabled:

- If the ACF is disabled and the operator selects Start ACF from the operator panel, but there is no magazine in the ACF or there is no cartridge in the import position in either the magazine or the priority cell, the ACF will return to the disabled state without changing the position of any medium. This does not constitute an error, and an error status will not be generated.
- If the ACF is enabled, the selection of Start ACF will be ignored.
- If, while unloading a cartridge to the magazine, the ACF determines that the destination cell is occupied or the magazine is not installed, it will attempt to unload the cartridge to the priority cell. If the priority cell is occupied, the ACF will cause a check condition and it will become disabled (an "extra cartridge" condition). The operator must clear the destination-full condition and select Start ACF on the operator panel to re-enable the ACF.
- Any cartridge that is in the export position can be removed from the ACF at any time. Empty cells that do not have their cell status lights active can be loaded at any time. If cartridges are added to magazine cells, the operator may need to re-enable the ACF as described previously to cause the ACF to recognize that these cartridges have been added.

- The magazine can be inserted at any time. The magazine can be removed while the ACF is in manual mode or while all of the associated cell status lights are inactive.
- Although not recommended as a normal operational procedure, cartridges in the import position can be removed from the ACF while it is active. The magazine also can be removed from the ACF while it is active. Any cartridge that was previously obtained from the magazine and is still in the ACF is ultimately returned to the priority cell.
- Generally, cartridges in the export position may be removed from the cell without affecting the operation of the drive, provided that none of the associated magazine status light indicators is active.

Chapter 4. Configuration Guidance

This chapter provides guidance on configuring the IBM 3590 High Performance Tape Subsystem on such IBM platforms as the ES/9000, S/390 Parallel Server, RISC/6000, and AS/400 systems. The IBM 3494 and 3495 Automated Tape Library Dataservers configurations and the new IBM 3494 models are also described.

IBM ES/9000 and S/390 Configurations



ES/9000 and S/390 Parallel Server

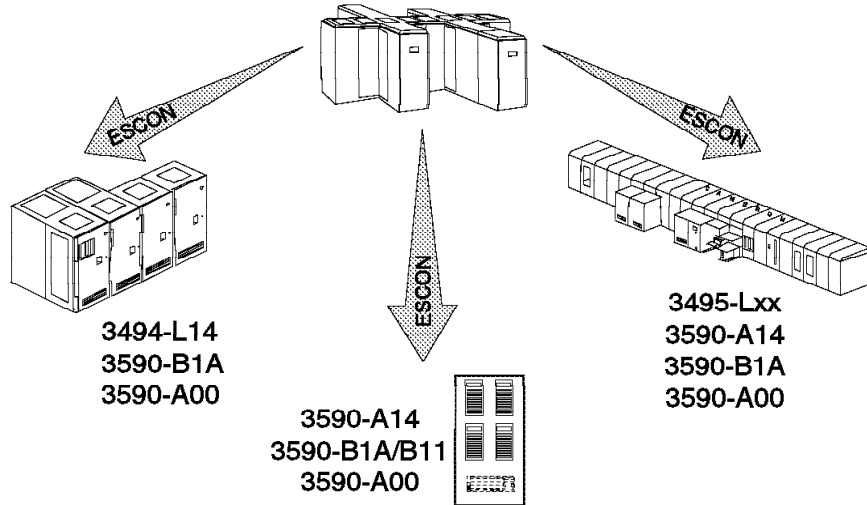

© IBM Corporation 1995

08/21/98

CESCON1

NTPQCH4.PRS

Figure 32. IBM ES/9000 and S/390 Configurations

4.1 IBM ES/9000 and S/390 Configurations

Figure 32 shows the IBM 3590 configurations that attach to IBM ES/9000 systems and S/390 Parallel Server systems.

4.1.1 Host Attachment

IBM ES/9000 systems and S/390 Parallel Server systems attach to the IBM 3590 configurations using only ESCON channels. Neither SCSI nor parallel channels are supported.

- IBM 3494 Automated Tape Library Dataserver with IBM 3590 drives

ES/9000 systems and S/390 Parallel Server systems attach to IBM 3590-B1A inside an IBM 3494 Automated Tape Library Dataserver using an IBM 3590-A00 control unit. A drive unit frame (Model D14) supports zero or one IBM 3590-A00 with a minimum of zero and a maximum of four IBM 3590-B1As. The library unit frame (or control unit frame, a Model L14) supports zero or one IBM 3590-A00 with a minimum of zero and a maximum of two IBM 3590-B1As. Each IBM 3590-A00 (with its attached IBM 3590) is one control unit function. One library supports up to a maximum of sixteen control unit functions. (See Section 4.6, "IBM 3494 Configurations" on page 78 and 4.6.5, "Mixed Configurations" on page 80.)

- IBM 3590-A14

The IBM 3590-A14 Model is a custom-built rack. It attaches to ES/9000 systems and S/390 Parallel Server systems using the two ESCON adapters in

the integrated IBM 3590-A00. The Model A14 can have from a minimum of one up to a maximum of four IBM 3590-B11s included. An IBM 3590-A14 order generates the rack only; the IBM 3590-A00 and up to four IBM 3590-B11s must be ordered separately. A fully configured IBM 3590-A14 is one complete tape subsystem.

- IBM 3495 Automated Tape Library Dataserver with IBM 3590 drives

As well as being an independent subsystem, the IBM 3590-A14 subsystem can be incorporated into an IBM 3495 Automated Tape Library Dataserver. When part of a library, each Model A14 subsystem must be fully configured with the maximum of four IBM 3590-B1As installed. One library supports up to a maximum of eight 3590-A14 tape subsystems (not Virtual Tape Server). (See Sections 4.2, “IBM 3495 Configurations” on page 69 and 4.3, “IBM 3495 Mixed Configurations” on page 71.)

Note: The IBM 3495 Model M10 Manual Tape Library Dataserver does not support the IBM 3590 High Performance Tape Subsystem.

4.1.2 ESCON Considerations

The considerations for ESCON are as follows:

- Supported distances

The supported distance between a subsystem control unit and a host is limited by the communication protocols and the timing of the signals passed between the host and control unit. The IBM 3590 Tape Control Unit is designed to support a maximum ESCON channel distance of 60 km. However, with the current ESCON implementations a distance of only 43 km is possible with an ESCON extended distance facility (XDF) channel, using a 20 km single-mode link to a director; a second 20 km single-mode link to a second director; and a final 3 km multimode LED link to the tape subsystem.

- Logical paths

The number of logical ESCON paths that can be defined for each physical path has been quadrupled, from 16 to 64. Thus an IBM 3590-A00 has two ESCON physical paths to an ES/9000 or S/390 Parallel Server host, each of which can have 64 logical paths, a total of 128 logical paths defined for the control unit. Only two of these paths can be concurrently active. Compare this with the IBM 3490-A20, for example, which has a maximum of eight ESCON physical paths to an ES/9000 host or hosts, each of which can have 16 logical paths giving a total of 128 logical paths defined for the control unit. Again, only two of these paths can be concurrently active.

Note: Do not confuse the number of logical paths supported by an ESCON control unit with the number of paths that can be defined from a system image to a single device. The processor complex channel subsystem (CSS) determines the number of paths that can be defined between a system image and a single device. The number of paths to a device depends on the processor type and model. ES/9000 711-based processors, 520-based processors, and 511-based processors can define up to eight physical channel paths to a device. All other ES/9000 and ES/3090 processors can define up to four paths to a device. This limit is enforced by the IOCP and the hardware configuration definition (HCD).

4.1.3 Library Manager Attachments

ES/9000 or S/390 Parallel Server hosts are connected to the IBM tape libraries by S/390 channels to the tape control units and drives. The data is passed down the ESCON channel to or from the drive, and the Library Manager commands are passed to the control unit, which in turn directs them to the Library Manager. The tape control units are connected to the Library Manager inside the library using up to eight RS-422 connections (sixteen for the IBM 3494).

IBM 3495 Configurations

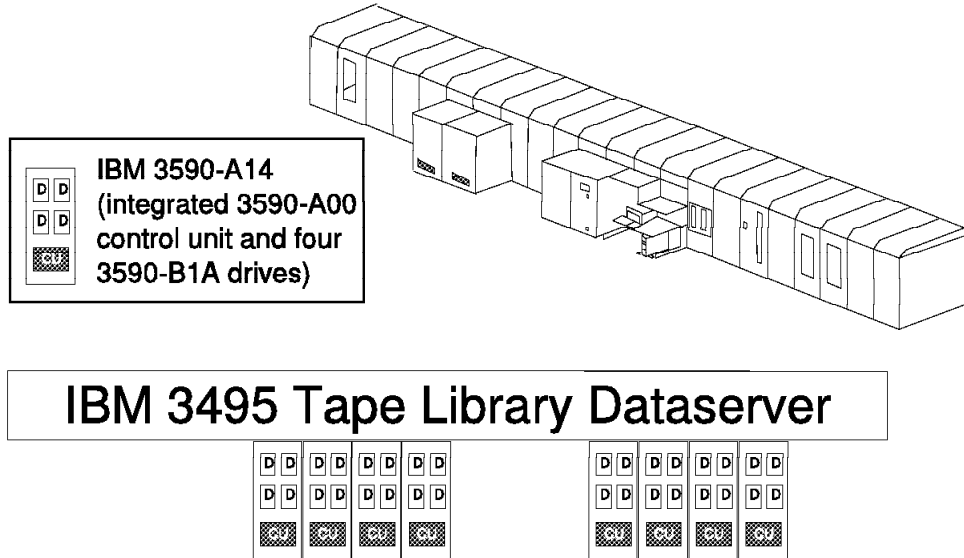

© IBM Corporation 1995

08/21/98

C348501

NTPQCH4.PRS

Figure 33. IBM 3495 Configurations

4.2 IBM 3495 Configurations

The IBM 3495 Automated Tape Library Dataserver Figure 33 is designed to meet the needs of customers who want to automate a large number of cartridges. Four models provide a range of cartridge capacities from 5660 to 18900 storage cells:

IBM 3495-L20 5660-6440 storage cells, 4 to 16 drives

IBM 3495-L30 8460-10580 storage cells, 4 to 32 drives

IBM 3495-L40 11280-14740 storage cells, 4 to 48 drives (4 to 32 drives if all IBM 3590)

IBM 3495-L50 14100-18900 storage cells, 4 to 64 drives (4 to 32 drives if all IBM 3590).

Each library model supports an intermix of the three tape subsystems that can be installed in an IBM 3495 library and their associated tape storage media.

All IBM 3490 Models A01, A02, and B04 and IBM 3490E models A10, A20, and B40 have a control unit (Model Axx) and a drive unit (model Bxx). Multiple B units can be controlled by a single A unit.

The IBM 3590 Model A14 is installed in the IBM 3495. The control function and four drive units are packaged within the same unit and each IBM 3590-A14 must be fully configured (that is, with the maximum of four IBM 3590-B1A drives installed). One IBM 3590-A14 forms a complete subsystem; there is no control

unit frame, and there are no additional B units that can be attached to the IBM 3590-A14. IBM 3590-A14 subsystems cannot be coupled together.

The number of tape drives that can be installed in an IBM 3495 library is model dependent, as shown above, but can also be limited by the number of internal communications paths with the Library Manager. Eight total paths are available and the different subsystems have different requirements:

- One path for each 3490-A01 or 3490-A10
- Two paths for each 3490-A02 or 3490-A20
- One path for each 3590-A00.

So, for example, using only IBM 3490 subsystems, the maximum number of drives that can be installed in an IBM 3495 library is 64, whereas using only IBM 3590 subsystems, the maximum number of drives is 32. Mixed configurations are possible, provided that the total number of paths to the Library Manager does not exceed eight.

The basic configuration of the IBM 3590 subsystem within the IBM 3495 Automated Tape Library Dataserver is similar to the IBM 3490E configuration. Subsystems are installed along the front side of the library as shown in the diagram. Note, however, that the IBM 3495 and IBM 3590 configurations are supported only on the IBM ES/9000 and S/390 Parallel Server platforms.

The configuration of a **IBM Magstar Virtual Tape Server (VTS)** when associated with a IBM 3495 tape library requires two 3590 Model A14 size frames to be installed side by side against the 3495 aisle. The Virtual Tape Server must consist of a 3495-B16 frame and a 3590-A14 frame. The 3495-B16 frame must be installed to the left of the 3590 frame when viewed from within the library. The Virtual Tape Server twin frames can reside in any location that an IBM 3490-Bxx Model could have previously. The 3495-B16 frame can also reside in the position that 3490-Axx boxes could be previously defined. If the 3495-B16 frame is installed alongside such a location, the adjacent 3495 wall would still have the storage capability of an 3490-Axx position 3495 frame (220 Slots).

See Section 7.11, "IBM 3495 Virtual Tape Server Configuration Guidelines" on page 173 for more detail on 3495 configuration.

IBM 3495 Mixed Configurations

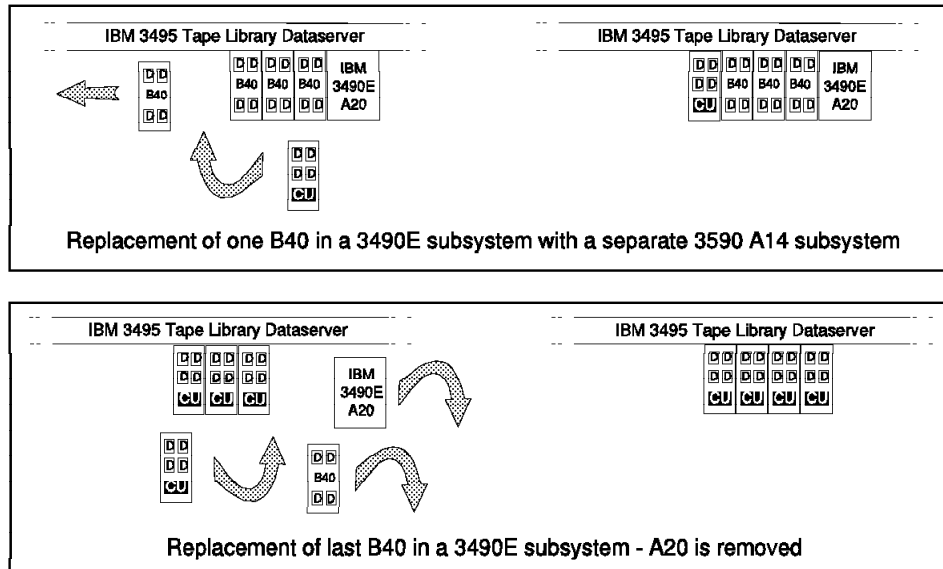

IBM Corporation 1995
02/01/95

C349502
NTPG.PRS

Figure 34. IBM 3495 Mixed Configurations

4.3 IBM 3495 Mixed Configurations

With IBM 3490 subsystems, the right side of the control unit model, Axx, is aligned with an IBM 3495 frame boundary. Subsequent Bxx models are attached to the left of the Axx unit: they do not line up with the frame boundaries. The spacing of the IBM 3495 frames and the IBM 3490 units requires that filler panels be installed to close a gap between the left-hand edge of the last Bxx unit in a string and the next IBM 3495 storage frame when a full string is not installed.

A rule of thumb for the placement of the IBM 3590-A14 models is this: wherever an IBM 3490E Model Bxx can be installed today, an IBM 3590-A14 can be installed instead. This placement rule applies whether replacing currently installed IBM 3490 subsystems or installing new IBM 3590 subsystems and is independent of the model of the IBM 3495 Automated Tape Library Dataserver.

illustrates how a complete IBM 3490 string would be replaced by IBM 3590-A14 subsystems. The first IBM 3590-A14 replaces the IBM 3490-Bxx unit that is farthest from the IBM 3490-Axx unit. Subsequent IBM 3590-A14 models are to be installed adjacent to existing IBM 3590s. When the fourth IBM 3590-A14 replaces the final IBM 3490 in the string, the IBM 3490 Model Axx control unit is removed, and a filler panel must be installed.

Note: Inside the library, in front of the IBM 3490-Axx unit, a special storage rack is installed. This is not replaced when the IBM 3490-Axx unit is removed, but the gap left between this special A unit wall and edge of the next IBM 3590-A14 is filled with the blank panel.

When adding a completely new IBM 3590 string, the first IBM 3590-A14 unit is installed in the position where the IBM 3490-Bxx closest to the IBM 3490-Axx unit would normally be positioned, with a filler panel to close the gap to the adjacent IBM 3495 frame. Additional IBM 3590-A14 units are installed adjacent to (and to the left of) the previously installed unit.

When installing an **IBM Magstar Virtual Tape Server (VTS)** into a 3495 the IBM 3495-B16 frame and its associated IBM 3590-A14 frame must be installed adjacent to each other. If these are installed in addition to an existing IBM 3490 subsystem, at least two IBM 3490-Bxx boxes must be replaced by these two VTS frames. If the VTS frames are to be the only subsystem associated with the IBM 3495 tape library, or installed with some non-VTS IBM 3590 drives, the IBM 3590-B16 frame can be installed in the location normally occupied by the IBM 3490-Axx unit. This then allows 220 tapes to be stored in the wall adjacent to the IBM 3495-B16. (260 - 40, Axx frame cut-out = 40 cells). The original 3495 Axx wall is left in place for convenience.

If a VTS is to be installed on an IBM 3495 in a location where a 3490 string had not previously been, the original 3495 wall can remain. The IBM 3495-B16 can be placed along the outside of this wall containing the full 260 cell locations.

As stated previously, up a maximum of eight IBM 3590-A14s can be added to the IBM 3495 Automated Tape Library Dataserver. However, in a mixed configuration of IBM 3490 and IBM 3590 subsystems, the total number of tape subsystems (or control unit functions) must not exceed eight; that is, the total number of IBM 3590-A14s together with any IBM 3490-Axx Models must not exceed eight because the number of RS-422 connections to the Library Manager within the library is currently limited to eight.

When a **Virtual Tape Server subsystem** is associated with an IBM 3495 tape library, the General Availability release of this subsystem consumes none of the eight IBM 3495 tape library RS-422 RTIC ports. No ports are required for the Virtual Tape Server controller or the four Virtual Tape Server IBM 3590 Model B1A tape drives. This is a different attachment methodology to the IBM 3494, which consumes some of the Library Manager RS-422 and RS-232 ports for VTS connection. The General Availability release of the Virtual Tape Server subsystem will use a dedicated LAN connection to provide the communication path between the Virtual Tape Server subsystem and its associated IBM 3495 Library Manager freeing up the RS-422 RTIC ports. This allows some of the larger IBM 3495 Tape Libraries to have multiple IBM Tape Subsystem configurations in addition to a Virtual Tape Server subsystem.

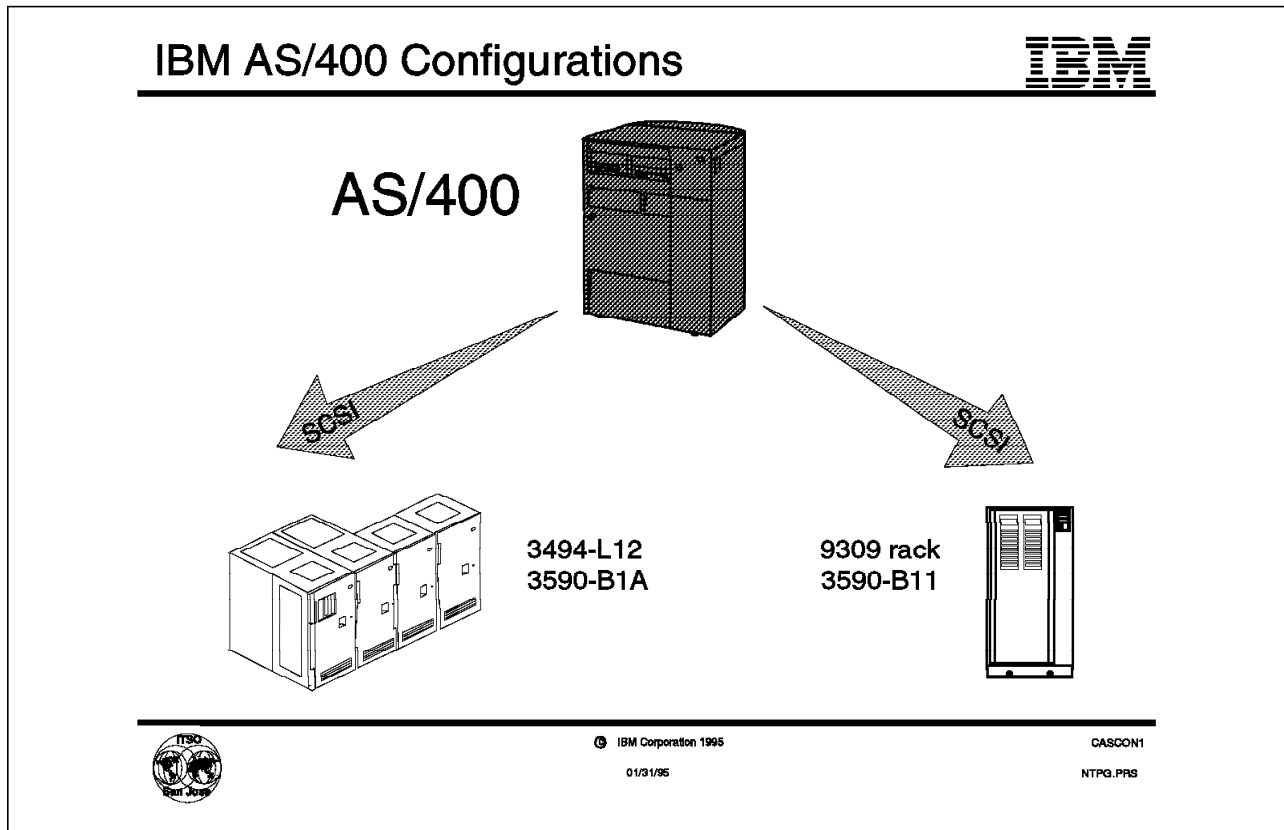

Figure 35. IBM AS/400 Configurations

4.4 IBM AS/400 Configurations

Figure 35 shows the IBM 3590 configurations that attach to IBM AS/400 systems.

4.4.1 Host Attachment

IBM AS/400 systems attach to the IBM 3590 configurations using only SCSI channels; neither ESCON nor parallel channels are supported:

- IBM 3494 Automated Tape Library Dataserver with IBM 3590 drives

AS/400 systems attach directly to an IBM 3590-B1A inside an IBM 3494 Automated Tape Library Dataserver using one or both of two SCSI adapters. An IBM 3494 drive unit frame (a Model D12) supports a minimum of zero and a maximum of six IBM 3590-B1As. The library unit frame (or control unit frame, a Model L12), supports a minimum of zero and a maximum of two IBM 3590-B1As. Each IBM 3590-B1A is one control unit function. One library supports up to a maximum of sixteen control unit functions. (See Section 4.6, "IBM 3494 Configurations" on page 78 and 4.6.5, "Mixed Configurations" on page 80.)

- IBM 3590-B11 in a standard IBM 9309 rack

The AS/400 attaches to the IBM 3590-B11, up to four of which can be installed in a standard IBM 9309 rack. A single IBM 3590-B11 is one complete tape subsystem, with a single tape drive.

4.4.2 SCSI Considerations

The AS/400 Tape/Disk Device Controller (Feature 6501) is required for attaching the IBM 3590 Model B11 or B1A. Each 6501 Feature provides two ports. Each port can support only one IBM 3590 Model B11 or B1A for a maximum of two IBM 3590 tape drives for each Feature 6501. Two AS/400 systems can connect to an IBM 3590 tape drive, but they must be connected through different SCSIs. Tape and DASD cannot be attached to the same Feature 6501.

The maximum SCSI channel distance supported is 25 m. This is a standard SCSI limitation rather than a limitation of the IBM 3590. Currently SCSI channel extender hardware is not available. This may be an issue where IBM 3590 subsystems are to replace current parallel attached IBM 3490E subsystems, which are supported at a maximum distance of 100 m.

Although the IBM 3590 tape drives and 6501 Feature on the AS/400 system have both Fast and Wide SCSI interfaces, an interposer is needed to connect the cable correctly. The interposer needed for connection to the AS/400 can be ordered as Feature 9410 on the IBM 3590 tape drives. See the *IBM 3590 High Performance Tape Subsystem Introduction and Planning Guide*, GA32-0329, for cable planning information.

4.4.3 Library Manager Attachments

AS/400 hosts attach to the IBM 3494 Automated Tape Library Dataserver using SCSI channels (to support IBM 3590 models) or parallel channels (to support IBM 3490-CxA models). The data and some commands (such as rewind) are passed down the SCSI channel to or from the drive, but the Library Manager commands are not passed down. Each AS/400 using the library must be attached to the Library Manager using a separate RS-232 or LAN (Token-Ring or Ethernet) interface in order to send the Library Manager commands. The number of RS-232 connections is limited to eight. The RS-232 cable length is a standard 50 ft (about 15 m). A 400 ft (about 123 m) cable is also available.

Note: The IBM 3590 drives are connected to the Library Manager using the RS-422 interfaces inside the library, in addition to the separate host connection to the Library Manager using the external RS-232 or LAN connections.

4.4.4 Special Features

The IBM 3590 can be attached to all Dxx (and subsequent) models of the AS/400 except Models X02 and P03.

The IBM 3590-B11 requires the IBM 9309 rack enclosure model 2 or space in an already installed rack.

IBM RISC System/6000 Configurations

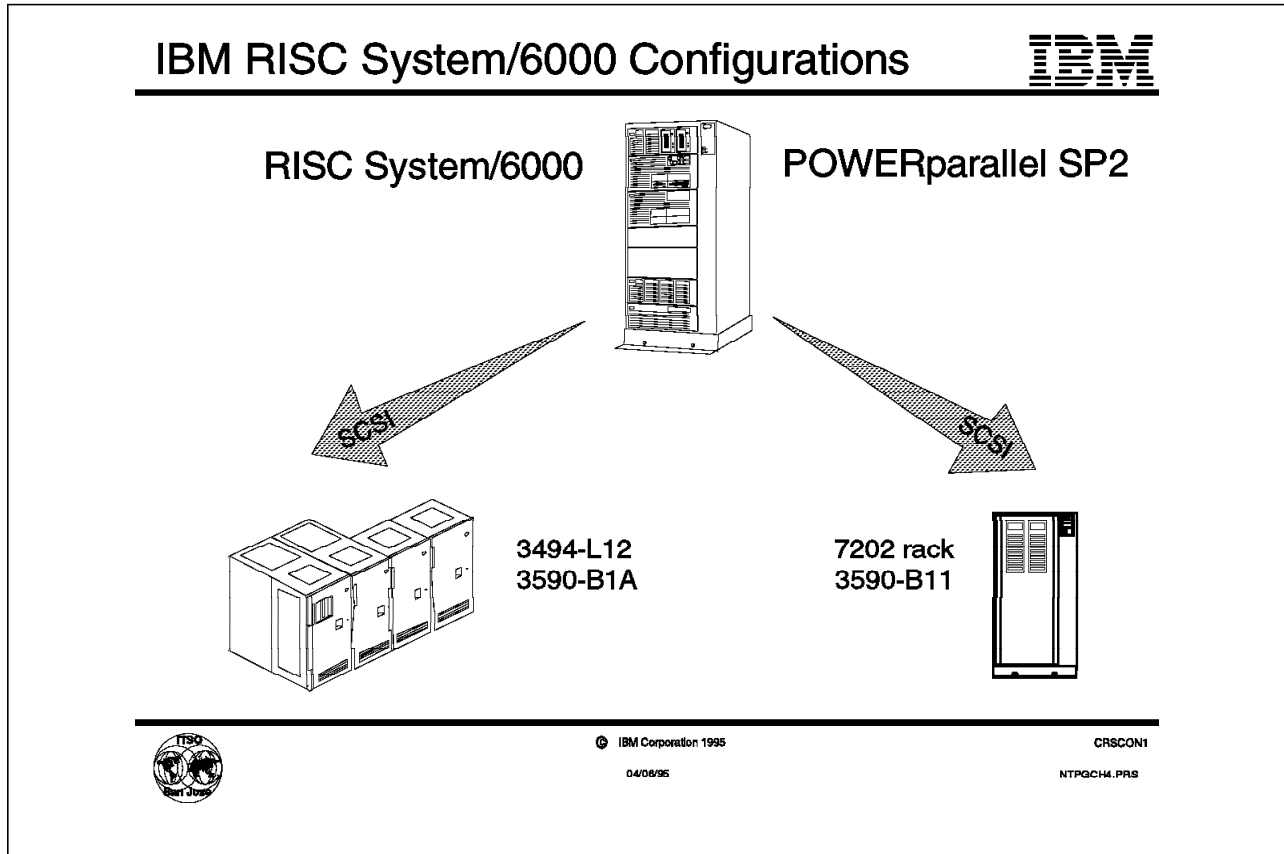

Figure 36. IBM RISC/6000 Configurations

4.5 IBM RISC/6000 Configurations

Figure 36 shows the IBM 3590 configurations that attach to IBM RISC/6000 and POWERparallel SP2 systems.

4.5.1 Host Attachment

IBM RISC/6000 systems attach to the IBM 3590 configurations using only SCSI channels: neither ESCON nor parallel channels are supported.

- IBM 3494 Automated Tape Library Dataserver with IBM 3590 drives

RISC/6000 systems attach directly to the IBM 3590-B1A within an IBM 3494 Automated Tape Library Dataserver using one or both of two SCSI adapters. An IBM 3494 drive unit frame (a Model D12) supports a minimum of zero and a maximum of six IBM 3590-B1As. The library unit frame (or control unit frame, a Model L12) supports a minimum of zero and a maximum of two IBM 3590-B1As. Each IBM 3590-B1A is one control unit function. One library supports up to a maximum of sixteen control unit functions. (See Section 4.6, "IBM 3494 Configurations" on page 78 and Section 4.6.5, "Mixed Configurations" on page 80.)

- The IBM 3590-B11 in a standard IBM 7202 or IBM 9309 rack

The RISC/6000 attaches to the IBM 3590-B11, up to four of which can be installed in an IBM 7202, IBM 9309, or industry standard EIA rack. A single IBM 3590-B11 is one complete tape subsystem, with a single tape drive.

4.5.2 SCSI Considerations

The maximum SCSI channel distance supported is 25 m. This is a standard SCSI limitation rather than a limitation of the IBM 3590. But if you use the SCSI-2 Differential High-Performance External I/O Controller (Feature 2420), the maximum total cable length is limited to 19 m. Currently SCSI channel extender hardware is not available.

The IBM 3590 SCSI differential interface is a 2-byte-wide SCSI Fast and Wide interface. When attaching to a 1-byte SCSI interface such as Feature 2420, a 1-byte to 2-byte interposer is required. The interposer can be ordered as Feature 9701 on the IBM 3590. For attachment to the SCSI-2 Differential Fast/Wide Adapter/A (Feature 2416), a 2-byte wide interposer is needed. It can be ordered as Feature 9702 on the IBM 3590. The IBM 3590 tape drive must be located at the end of the bus when attached to a 1-byte SCSI interface. If multiple tape drives are attached to a RISC/6000 bus, only one of them must be at the end of the bus. See the *IBM 3590 High Performance Tape Subsystem Introduction and Planning Guide*, GA32-0329, for proper cabling.

The SCSI interface supports a maximum 2 MB block size.

Although multiple host systems can be attached to an IBM 3590 tape drive, the host system cannot use the tape drive simultaneously. The IBM 3590 tape drive can be varied online to only one host system at a time.

4.5.3 Library Manager Attachments

RISC/6000 hosts attach to the IBM 3494 Automated Tape Library Dataserver using SCSI channels (to support IBM 3590 or IBM 3490-CxA SCSI Models) or ESCON or parallel channels (to support IBM 3490-CxA ESCON or parallel models).

The data and some commands (such as rewind) are passed down the SCSI channel to or from the drive, but the Library Manager commands are not passed down. Each RISC/6000 using the library must be attached to the Library Manager using a separate RS-232 or LAN (Token-Ring or Ethernet) interface in order to send the Library Manager commands. The number of RS-232 connections is limited to eight. The RS-232 cable length is a standard 50 ft (about 15 m). A 400 ft (about 123 m) cable is also available.

Note: The IBM 3590 drives are connected to the Library Manager using the RS-422 interfaces inside the library, in addition to the separate host connection to the Library Manager using the external RS-232 or LAN connections.

4.5.4 Special Features

For SCSI attachment to devices the RISC/6000 host requires either Feature 2416 or 2420. The IBM 3590 is supported on all models of the RISC/6000 that support these features.

Feature 2416 is the IBM SCSI-2 Differential Fast/Wide Adapter/A. This is the recommended feature for taking advantage of the faster data rate of the IBM 3590. It is a dual-ported fast (10 MHz) and wide (2 bytes) SCSI Micro Channel Adapter that can provide synchronous SCSI bus data rates of up to 20 MB/s.

Feature 2420 is the SCSI-2 Differential High Performance External I/O Controller, which provides attachment of external SCSI-2 differential devices. It supports a data rate of up to a 10 MB/s.

The IBM 3590-B11 requires the IBM 7202, IBM 9309 rack or space in an already installed rack.

4.5.5 POWERparallel SP2

The above details also apply to the POWERparallel SP2 systems.

4.5.6 Sun Systems

The IBM 3590 is supported on all workstations that support a SCSI Differential Ended Adapter. The IBM 3590-B11 requires the IBM 9309, 7202, or 7015-R00 rack or space in an already installed rack.

Note: The maximum block size for Sun systems is 256 KB. This is a limitation of the Sun SCSI Differential Ended Adapter card.

IBM 3494 Configurations

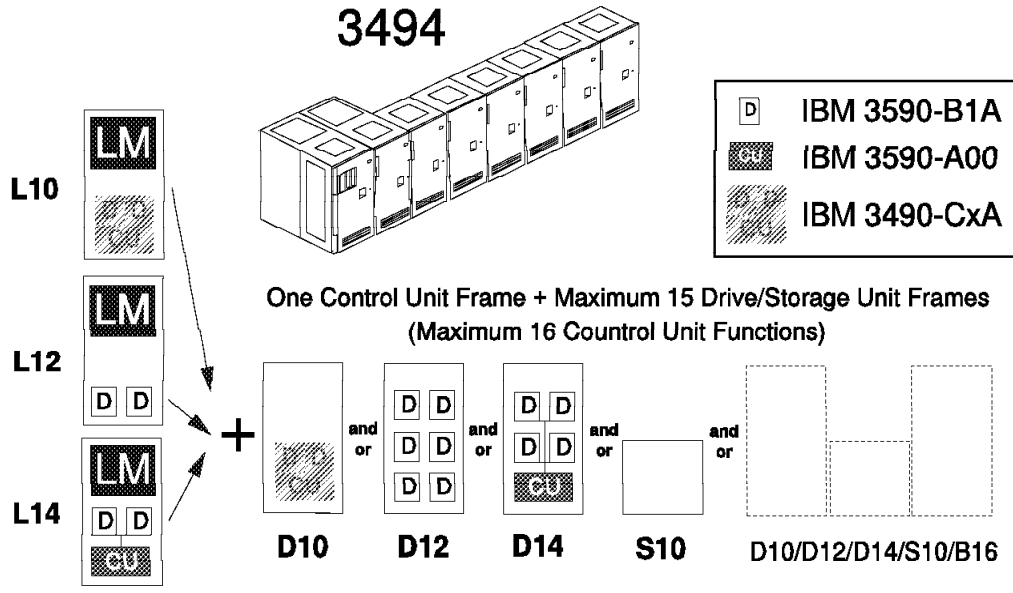

© IBM Corporation 1995
08/21/98

C349401
NTPQCH4.PRS

Figure 37. IBM 3494 Configurations

4.6 IBM 3494 Configurations

The IBM 3494 Automated Tape Library Dataserver is designed for customers whose cartridge storage capacity needs are between 210 and 6210 cartridges. A given configuration consists of one to sixteen frames. One control unit frame and any combination of storage and drive unit frames for the first eight frames, then set configuration apply for the last expansion of eight frames. The last eight frame must be added as groups of four. Each group of four is a set configuration of two drive frames then two storage frames.

A variety of frame types is available to customize the library capabilities. Four basic models of the IBM 3494 Automated Tape Library Dataserver combine to make up the library:

- Control-unit frame (also referred to as the *library unit*), which contains one 3490E-C1A or C2A, or one or two IBM 3590-B1A tape drives.
- Zero to fifteen optional storage-unit frames
- Zero to fifteen optional drive-unit frames, which can each contain one IBM 3490E-C1A or C2A, or up to six IBM 3590-B1A drives.
- IBM Magstar Virtual Tape Server subsystem, which consist of one IBM 3494-B16 and one IBM 3494-D12.

The IBM 3494 Automated Tape Library Dataserver supports a maximum of sixteen tape control unit connections; each IBM 3590-B1A (when attached without

an IBM 3590-A00), each IBM 3590-A00 (with any number of IBM 3590-B1As attached), and each IBM 3490-C1A or C2A utilizes one control unit connection. Thus the maximum number of tape drives supported in a single library depends on the mixture of tape drive models installed.

4.6.1 IBM 3494 Model L10 (Parallel, ESCON, and SCSI)

The original model of the IBM 3494 library is the L10. The library and drive units house one or other of the IBM 3490E-CxA models, containing one or two drives and a single integrated control unit. It is not possible to exceed sixteen control unit connections in a single library, this is the maximum number of Library Manager RS-422 control unit ports available. It is possible in some potential configurations to over define and exceed the sixteen control unit connections in a single library. This is because there can be eleven drive frames in the library, and each drive frame could contain up to six control unit functions (D12). Great care has to be taken when planning the structure of an IBM 3494 tape library.

An IBM 3490-CxA can be attached to host systems using any combination of two out of ESCON, parallel, or SCSI adapters. However, note that any single host system can be attached to only a single control unit using one type of adapter.

4.6.2 IBM 3494 Model L12 (SCSI Only)

The first new model of the IBM 3494 library is the L12, the library control unit frame. This library control unit frame houses a maximum of two SCSI-attached IBM 3590-B1A drives. Each SCSI-attached IBM 3590-B1A drive houses its own integrated control unit function, and consumes one of the sixteen possible 3494 control unit connections. An IBM 3494-L12 has only fourteen available control unit connections available for additional IBM 3494-Dxx and IBM 3494-B16 (VTS) frames.

Each IBM 3590-B1A can be attached to host systems using one or two SCSI adapters. The IBM 3590-B1A does not support any other host interface.

4.6.3 IBM 3494 Model L14 (ESCON Only)

The second new model of the IBM 3494 library is the L14. The library control unit frame houses a maximum of two IBM 3590-B1A drives, which are controlled by an IBM 3590-A00, and the drive unit frame houses a maximum of four IBM 3590-B1A drives, which are controlled by an IBM 3590-B1A. With the IBM 3590-A00 installed each library or drive unit uses only one control unit attachment. Thus with one library unit and eleven ESCON (IBM 3494-D14) drive units (housing a total of 46 drives) the installed tape drives are at the maximum number.

Note: An IBM 3494-D14 frame with its IBM 3590-A00 control unit can house only four IBM 3590-B1A drives. (See Section 4.7.2, "Drive Unit Frame Models" on page 83.)

Each IBM 3590-A00 is attached to host systems using the two ESCON adapters. The IBM 3590-A00 does not support any other host interface.

4.6.4 IBM 3494 Model B16 (Virtual Tape Server subsystem)

The IBM 3494 Model B16 is a new model introduced to support the IBM Magstar Virtual Tape Server (VTS) within the IBM 3494 Tape Library. This new frame must be installed alongside an IBM 3494-D12 frame.

Please see Section 7.8, "IBM 3494 Virtual Tape Server Configuration Guidelines" on page 167 for more detail on IBM 3494 Virtual Tape Server configurations.

4.6.5 Mixed Configurations

The new model types are described above in three groups, or families. However, the old and new models of the 3494 frames can be combined in one library, provided that the overall configuration rules stated previously are not broken. For example, the L10, L12, and L14 library units support S10 storage units, or as the Feature 5400 of the L10, and the D10, D12, and D14 drive units, as well as the 5300 drive unit feature of the L10. Basically, any combination is acceptable.

The number of tape drives that can be installed in an IBM 3494 library is model-dependent and also can be limited by the number of internal communications paths with the Library Manager. Eight paths are available, and the different subsystems have different requirements:

- One path for each IBM 3490-C1A or 3490-C2A
- One path for each IBM 3590-A00 (including its attached drives)
- One path for each direct SCSI-attached IBM 3590-B1A.

Previously, with the IBM 3490E-CxA Models, it was not possible to exceed the supported number of control unit functions; no more than eight control units could be installed in the maximum of eight IBM 3494 frames. Now, a single drive unit frame can accommodate six native SCSI-attached IBM 3590 drives, each with its own integrated control unit. Or a frame may contain four drives with one 3494 control unit connection. Also, a 3494 can now have up to sixteen frames and can support sixteen control unit functions.

So, for example, using only IBM 3490 subsystems, the maximum number of drives that can be installed in an IBM 3494 library is 32, whereas using only direct SCSI-attached IBM 3590-B1A drives, the maximum number of drives is 16, and using only ESCON-attached IBM 3590-B1A drives through the IBM 3590-A00, the maximum number of drives is 46. Any mixed configurations are possible, provided that the total number of paths to the Library Manager does not exceed sixteen.

If a Virtual Tape Server is included in the IBM 3494 library it uses either five or eight of the LM RS-422 connections. Five RS-422 connections are used if the three VTS drive option is chosen. Three ports being used by the drives, and two for the VTS controller. Eight RS-422 connections are used if the six VTS drive option is chosen. Six ports being used by the drives, and two for the VTS controller. If a Virtual Tape Server subsystem is installed on an IBM 3494 tape library, this will reduce the number of RS-422 and RS-232 ports available for tape control unit and host connection.

The reduction of ports by the installation of the VTS option will leave either seven (12-5) or four (12-8) RS-422 connections for other tape drive control units. The reason the total number of RS-422 ports does not total the potential of sixteen, is that a group of four RS-232 must be left in their native communication

protocol mode to enable the connection of the single RS-232 VTS controller path. This leaves a maximum of 12 RS-422 ports to be shared between VTS and non-VTS drives. Feature 5229, the second RTIC card, will have to be installed to get the maximum 12 RS-422 ports.

Any mixed configurations are possible, provided that the total number of paths to the Library Manager does not exceed those available.

It is easy to see that with different hosts and platforms sharing a mixed configuration of IBM 3490E and IBM 3590, it is necessary to exercise care in planning the IBM 3494 configuration. Please refer to Chapter 7, "The IBM Magstar Virtual Tape Server" on page 147 or the Redbook, *The IBM Magstar Virtual Tape Server and Enhancements to Magstar: New Era In Tape* for more details on configuring an IBM 3494 with the Virtual Tape Server subsystem.

4.6.6 Library Sharing between Different Hosts

It is easy to see that with different hosts and platforms sharing a mixed configuration of IBM 3490E and IBM 3590, it is necessary to exercise care in planning the IBM 3494 configuration.

Any one IBM 3590-B1A can have only one type of channel attachment, either two ESCON adapters (using the IBM 3590-A00) or two SCSI adapters, but not one of each. This may be important when sharing tape drives between different platforms using different channel protocols. IBM 3490-CxA can be configured with any combination of channel adapters (two in total for any one Model CxA), ESCON, parallel, or SCSI. So, although a tape drive can only be online to any one host at a time, and any one host must "see" a control unit as either ESCON, parallel, or SCSI attached, it is possible to attach one Model CxA control unit to two different hosts using different channel interfaces and then switch the tape drives between the two hosts as required. However, this scenario is not possible with an IBM 3590 tape drive. For further information on issues regarding sharing tape libraries and tape drives see the *Guide to Sharing and Partitioning IBM Automated Tape Library Dataservers*.

IBM 3494 Model Summary



Library Unit	L10	L12	L14
Integrated CU	Yes	No	Yes
Tape drives	3490-CxA	3590-B1A	3590-B1A
Channel type	S/390 & SCSI	SCSI	ESCON
Drive unit	#5300/D10	D12	D14
Storage unit	#5400/S10	S10	S10
Max drives /DU	2	6	4
Max drives /LU	2	2	2
Max CU function	8	8	8



© IBM Corporation 1995

C3494T1

Figure 38. IBM 3494 Model Summary

4.7 IBM 3494 Model Summary

In the previous section, we discussed the IBM 3494 model families defined in terms of the tape drives used inside each model, that is, IBM 3490, IBM 3590 SCSI attached, and IBM 3590 ESCON attached. In this section, we provide an overall summary in terms of the IBM 3494 frame types and model numbers and discuss the IBM 3494-L10 model and feature upgrades.

4.7.1 Control Unit Frame Models

- IBM 3494-L10** contains one IBM 3490 Model C1A or Model C2A; the Library Manager; the cartridge accessor; the (optional) convenience input/output station; and cartridge storage cells.
- IBM 3494-L12** contains zero, one, or two IBM 3590 Model B1A tape devices; the Library Manager; the cartridge accessor; the (optional) convenience input/output station; and cartridge storage cells.
- IBM 3494-L14** contains zero or one IBM 3590 Model A00 tape control unit; zero, one, or two IBM 3590 Model B1A tape devices; the Library Manager; the cartridge accessor; the (optional) convenience input/output station; and cartridge storage cells. The IBM 3590-A00 is required if an IBM 3590-B1A is installed in the frame.

4.7.2 Drive Unit Frame Models

IBM 3494-D10 contains one IBM 3490 Model C1A or Model C2A; and cartridge storage cells.

IBM 3494-D12 contains a minimum of zero and a maximum of six IBM 3590 Model B1A tape devices; and cartridge storage cells.

IBM 3494-D14 contains zero or one IBM 3590 Model A00 tape control unit; a minimum of zero and a maximum of four IBM 3590 Model B1A tape devices; and cartridge storage cells. The IBM 3590-A00 is required if an IBM 3590-B1A is installed in the frame.

4.7.3 Storage Unit Frame Models

IBM 3494-S10 contains only cartridge storage cells.

4.7.4 VTS Unit Frame Models.

IBM 3494-B16 in combination with a dedicated IBM 3494-D12 frame, contains the required hardware and microcode to enable full 3590 Magstar tape storage capacity plus storage cell locations.

4.7.5 IBM 3494-L10 Features

Before the release of the above models, the drive and storage unit frames for the IBM 3494 were described by the IBM 3494 Feature codes listed below. The features, although now superseded by models, cannot be converted to models through upgrades. The features are:

5300 The drive-unit frame for the IBM 3494-L10 subsystem Feature 5300 is similar to the IBM 3494 Model D10 but included the mounting hardware for the IBM 3490 subsystem.

5302 Feature 5300 can be upgraded to Feature 5302, which is the drive unit frame similar to the IBM 3494 Model D12. Feature code 5302 provides the hardware to accommodate up to two IBM 3590-B1A drives; other configurations require an RPQ (see Table 4 on page 84).

5304 Feature 5300 can be upgraded to this feature, which is the drive unit frame similar to the IBM 3494 Model D14. Feature code 5304 provides the hardware to accommodate up to two IBM 3590-B1A drives and one IBM 3590-A00 control unit; other configurations require an RPQ (see Table 4 on page 84).

5400 The storage-unit frame for the IBM 3494-L10 subsystem, Feature 4500, is equivalent to the IBM 3494 Model S10.

4.7.6 Installation Features and Upgrades

The following model upgrades are available to migrate to the new models of IBM 3494:

- IBM 3494 Model L10 to a Model L12
- IBM 3494 Model L10 to a Model L14
- IBM 3494 Model D10 to a Model L12
- IBM 3494 Model D10 to a Model D14.

Model conversions not listed above must be requested through an RPQ. Some models and features have been added specifically to accommodate migration.

Table 4 on page 84 gives the upgrade features for the IBM 3494-L10. Features cannot be upgraded to models.

<i>Table 4. IBM 3494-L10 Upgrade Features</i>		
Upgrade to IBM 3494-L10 Feature	Add Feature	Plus RPQ
5300 drive unit frame to install up to two SCSI IBM 3590-B1As	5302	None
5300 drive unit frame to install up to four SCSI IBM 3590-B1As	5302	8B3166
5300 drive unit frame to install up to six SCSI IBM 3590-B1As	5302	8B3167
5300 drive unit frame to install up to two IBM 3590-B1As + ESCON IBM 3590-A00	5304	None
5300 drive unit frame to install up to four IBM 3590-B1As + ESCON IBM 3590-A00	5304	8B3168
5400 storage unit frame to accept new IBM 3590 cartridges	None	None

For a description of the features required when ordering the IBM 3590 for integration into new or existing configurations, see Section 4.9, "IBM 3590 Feature Codes" on page 86.

IBM 3494 Capacity Guidelines



3494 Models or Features		Supported number of:				
		3490 CxA	3590 B1A	3590 A00	Cartridges no dual gripper	Cartridges + dual gripper
L10, L12, or L14	Control unit frame	1 (in L10)	0, 1, 2 (L12, L14)	0, 1 (in L14)	210-240	196-216
#5400, S10, #5300, D10, D12, or D14	Storage unit or empty drive unit	-	-	-	400	360
#5300 or D10	Drive unit frame plus 1x3490	1	-	-	300	270
#5302 or D12	Drive unit frame plus 2x3590	-	1, 2	-	335	305
#5302 or D12	Drive unit frame plus 4x3590	-	3, 4	-	290	260
#5302 or D12	Drive unit frame plus 6x3590	-	5, 6	-	250	230
#5304 or D14	DU frame plus 2x3590 ESCON	-	1, 2	1	345	305
#5304 or D14	DU frame plus 4x3590 ESCON	-	3, 4	1	305	275



© IBM Corporation 1995

C3494T2

04/10/95

NTPQCH4.PRS

Figure 39. IBM 3494 Capacity Guidelines

4.8 IBM 3494 Capacity Guidelines

Figure 39 summarizes the number of cartridge cells available in the IBM 3494 frames according to the tape drives and features installed.

The number of available cartridge cells in the library control unit frame does not depend on the IBM 3494 model. The maximum number is 240, and this number is reduced if the convenience input/output station is installed. The installation of the dual gripper makes some other cells inaccessible, as indicated in the two columns. The lower number of the range for the library control unit applies when the convenience input/output station is installed.

The cells available in the other frames depend on the number and model of tape drives installed, as well as the dual gripper. As IBM 3590-B1A drives are added, cartridge storage cells are displaced.

A potential range of 210 to 6210 cartridges is possible in a 1-to-16-frame capable IBM 3494 subsystem. (An empty drive unit frame can contain an equal number of tapes as a storage unit).

IBM 3590 Feature Codes

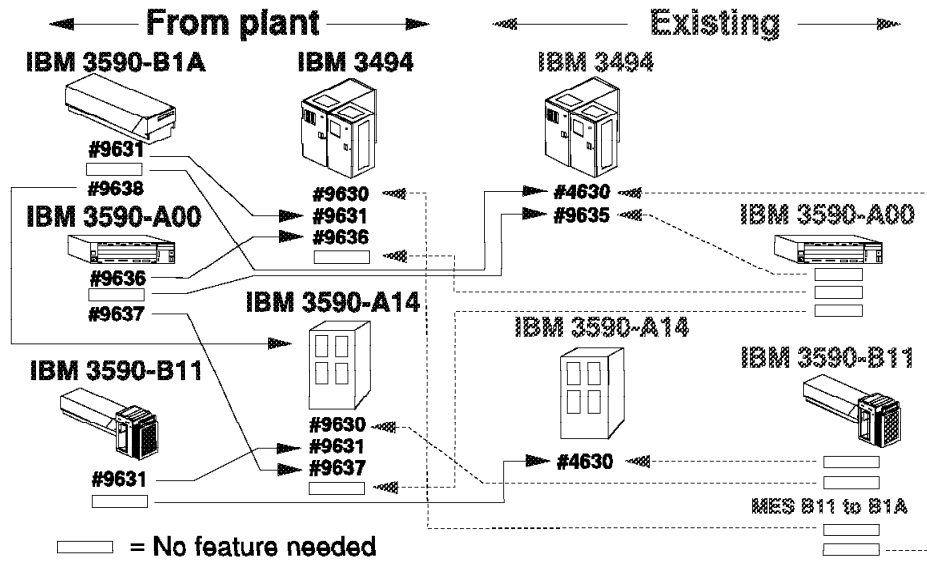

© IBM Corporation 1995
08/21/98

CFEAT01
NTPQCH4.PRS

Figure 40. IBM 3590 Feature Codes

4.9 IBM 3590 Feature Codes

Figure 40 shows which feature codes are to be ordered when installing new or existing IBM 3590s in new or existing IBM 3494s and IBM 3590-A14s. Table 5 on page 87 summarizes the features codes.

The first column in Table 5 on page 87 shows the install unit, that is, the IBM 3590 unit which is to be installed (in either an IBM 3494 library or an IBM 3590-A14 rack). The Install Unit Feature Number column shows the feature that must be specified on the install unit. N/A indicates, for example, that the IBM 3590-B11 cannot be installed in an IBM 3494 library.

Table 5. IBM 3590 Feature Codes

IBM 3590 Unit to Be Installed	New IBM 3494		Existing IBM 3494		New IBM 3590-A14		Existing IBM 3590-A14	
	Install Unit Feature Number	Feature on IBM 3494	Install Unit Feature Number	Feature on IBM 3494	Install Unit Feature Number	Feature on IBM 3590-A14	Install Unit Feature Number	Feature on IBM 3590-A14
New B1A	9631	9631	none	4630	9638	9638	none	4638
Existing B1A	none	9630	none	4630	none	9639	none	4638
New B11	N/A	N/A	N/A	N/A	9631	9631	none	4630
Existing B11	N/A	N/A	N/A	N/A	none	9630	none	4630
New A00	9636	9636	none	4635	9637	9637	N/A	N/A
Existing A00	none	9635	none	4635	N/A	N/A	N/A	N/A

These features provide only the hardware to install the subsystems into the frames; the actual drives and control units must be ordered separately.

4.9.1 Description of No-Charge Features

Feature numbers 9xxx are nonchargeable and are for installation at time of manufacture:

- **9630**
 - An IBM 3494 feature that supplies the hardware to allow for later field installation of one IBM 3590-B1A into a frame
- **9631**
 - An IBM 3494 feature that causes one IBM 3590-B1A to be integrated into an IBM 3494 frame at the factory
 - An IBM 3590-B1A feature denoting that the tape drive is integrated into an IBM 3494 frame at the factory
 - An IBM 3590-B11 feature denoting that the tape drive is integrated into an IBM 3590-A14 frame at the factory
 - An IBM 3590-A14 feature that causes one IBM 3590-B11 to be integrated into an IBM 3590-A14 frame at the factory
- **9635**
 - An IBM 3494 feature that supplies the hardware to allow for later field installation of one IBM 3590-A00 in a frame. This feature is applicable only to IBM 3494 Models L14 and D14.
- **9636**
 - An IBM 3494 feature that causes one IBM 3590-A00 to be integrated into an IBM 3494 frame at the factory. This feature is applicable only to IBM 3494 Models L14 and D14.
- **9637**

- An IBM 3590-A14 feature that causes one IBM 3590-A00 to be integrated into an IBM 3590-A14 frame at the factory
- An IBM 3590-A00 feature denoting that the control unit will be integrated into an IBM 3590-A14 frame at the factory.
- **9638**
 - An IBM 3590-A14 feature that causes one IBM 3590-B1A to be integrated into an IBM 3590-A14 frame at the factory
 - An IBM 3590-B1A feature denoting that the control unit will be integrated into an IBM 3590-A14 frame at the factory.
- **9635**
 - An IBM 3590-A14 feature that supplies the hardware to allow for later field installation of one IBM 3590-B1A into the IBM 3590-A14 frame.

4.9.2 MES Field-Installation Features

- **4630**
 - An IBM 3494 feature that, when applied to the IBM 3494 Model D10, supplies the hardware to allow for field installation of an IBM 3490 Model CxA subsystem.
 - An IBM 3494 feature that, when applied to the IBM 3494 (except the models D10 and B16), supplies the hardware to allow for field installation of one IBM 3590-B1A. It is applicable if Feature 9630 was not ordered at time of manufacture.
- **4635**
 - - An IBM 3494 feature that supplies the hardware to allow for field installation of one IBM 3590-A00 in a frame. This feature is applicable only to IBM 3494 Models L14 and D14 and where Feature 9635 was not ordered at time of manufacture.
- **4638**
 - - An IBM 3590-A14 feature that supplies the hardware to allow for field installation of one IBM 3590-B1A in the IBM 3590-A14 frame. This feature is applicable if Feature 9639 was not ordered at time of manufacture.

4.9.3 New Features

This covers some of the new features not applicable to the units in Table 5 on page 87.

- **9010**
 - An IBM 3494-D12 feature that denotes that it is attached to the IBM 3494-B16 and forms part of the Virtual Tape Server.
- **9012**
 - An IBM 3494-A14 feature that causes it to be integrated into an IBM 3495 library at the factory.
- **9020**
 - An IBM 3494-A14 feature that denotes that it is attached to an IBM 3495-B16 Virtual Tape Server; it has no IBM 3590-A00 controller installed, and is mutually exclusive with feature 9637.

- **3311 and 3312**

- IBM 3590-A00 features that provide the ESCON/SCSI adapters. 3311 is a required feature and supplies the first ESCON and SCSI adapter; Feature 3312 is optional and supplies the second ESCON and SCSI adapter.

- **2710, 2711, and 2712**

- IBM 3590-A00 features that provide rapid remote support capability. Each IBM 3590-A00 must have one of these; Feature 2710 is applied to the first IBM 3590-A0 in an installation; Feature 2711 is applied to the second; and Feature 2712 is applied to No.s 3 through 14.

IBM 3590 Subsystem Host Interfaces



Host System	3490E			3590		
	ESCON	SCSI	Parallel	ESCON	SCSI	Parallel
ES/9000, S/390	✓	▒	✓	✓	▒	▒
AS/400	▒	✓	✓	▒	✓	▒
RISC System/6000	✓	✓	✓	▒	✓	▒
POWERparallel SP2	✓	✓	✓	▒	✓	▒
Sun	▒	✓	▒	▒	✓	▒



© IBM Corporation 1995

04/06/95

CCONTAB

NTPQCH4.PRS

Figure 41. IBM 3590 Subsystem Host Interfaces

4.10 IBM 3590 Subsystem Host Interfaces

Figure 41 briefly summarizes the IBM 3590 subsystem host interfaces. The IBM 3490E support is listed for reference. A check mark indicates support.

Table 6 on page 91 shows an overview of the platform and software support in slightly more detail. The table indicates the software and hardware supported with the various configurations. The check mark indicates support; S stands for SCSI, E stands for ESCON, and P stands for parallel attachments. For precise details of software supporting levels see Section 5.1, "IBM 3590 Software Support Overview" on page 94.

Table 6. Supported Configurations for the IBM 3490E and IBM 3590

Platform	3490E									3590					
	Native			In 3494			In 3495			Native		In 3494		In 3495	
	S	E	P	S	E	P	S	E	P	S	E	S	E	S	E
ES/9000, S/390	-	√	√	-	√	√	-	√	√	-	√	-	√	-	√
AS/400	√	-	√	-	-	√	-	-	-	√	-	√	-	-	-
RISC/6000	√	√	√	√	√	√	-	√	√	√	-	√	-	-	-
POWERParallel SP2	√	√	√	√	√	√	-	√	√	√	-	√	-	-	-
Sun	√	-	-	√	-	-	-	-	-	√	-	√	-	-	-
MVS DFSMS 1.2.0	-	√	√	-	√	√	-	√	√	-	√	-	√	-	√
MVS DFSMS 1.1.0	-	√	√	-	√	√	-	√	√	-	-	-	-	-	-
MVS BTLS	-	√	√	-	√	√	-	√	√	-	-	-	-	-	-
Non-DFSMS	-	√	√	-	-	-	-	-	-	-	-	-	-	-	-
VM/ESA V2.1.0	-	√	√	-	√	√	-	√	√	-	√	-	√	-	√
VSE/ESA V2	-	√	√	-	√	√	-	-	-	-	√	-	√	-	-
VM/VSE or VGS	-	√	√	-	√	√	-	(√)	(√)	-	√	-	√	-	-
OS/400 V3.1	√	-	√	-	-	√	-	-	-	√	-	√	-	-	-
AIX/6000 V3.2.5	√	√	√	√	√	√	-	√	√	√	-	√	-	-	-
AIX/6000 V4.1	√	-	-	√	-	-	-	-	-	√	-	√	-	-	-
SunOS/Solaris	√	-	-	√	-	-	-	-	-	√	-	√	-	-	-

Chapter 5. Software Support for the IBM 3590 High Performance Tape Subsystem

This chapter introduces the software support for the IBM 3590 High Performance Tape Subsystem, including the Magstar tape drive. It also provides information about the levels of software that support the new devices and the new functions and features that the software provides.

IBM 3590 Software Support Overview



- ES/9000 and S/390 Parallel Server Environment
 - ◆ MVS/ESA
 - ◆ VM/ESA
 - ◆ VSE/ESA
 - ◆ TPF
- AS/400 Environment
- RISC System/6000 and POWERparallel SP2 Environment
- SUN Environment



© IBM Corporation 1995

04/08/95

NTPQCHE.PRS

Figure 42. IBM 3590 Software Support Overview

5.1 IBM 3590 Software Support Overview

Below we list the IBM 3590 software support for each environment.

5.1.1 ES/9000 and S/390 Parallel Server Environment

5.1.1.1 MVS/ESA System

The following are the minimum releases of software:

- MVS/ESA SP 4.3 + SPE
- MVS/ESA SP 5.1.0 + SPE
- MVS/ESA SP 5.2.0 + SPE
- JES3 4.2.1 + SPE
- JES3 5.1.1 + SPE
- JES3 5.2.1 + SPE
- DFSMS/MVS 1.2.0 or higher + SPE
- EREP 3.5.0 + PTF
- ADSM for MVS in a future release
- DFSORT Release 12 + SPE
- DITTO/ESA Release 1

Note:

- Toleration PTFs will be required for DFSMS/MVS 1.1.0 and DFSMS/MVS 1.2.0 without the IBM 3590 Support SPE when sharing an IBM 3494 or 3495

Automated Tape Library Dataserver with DFSMS/MVS 1.2.0 with the IBM 3590 SPE installed.

- BTLS does not support the IBM 3590 High Performance Tape Subsystem at announcement time.
- DFDSS V2.5 does not support the IBM 3590 but DFSMSdss 1.2.0 does.

5.1.1.2 VM/ESA System

- VM/ESA Version 2
- EREP 3.5.0 + PTF
- DITTO/ESA Release 1
- ADSM for VM in a future release

5.1.1.3 VSE/ESA System

- VSE/ESA Version 2 - available in the second quarter of 1996
- EREP 3.5.0 + PTF
- ADSM for VSE in a future release
- DITTO/ESA Release 1

5.1.1.4 Transaction Processing Facility (TPF) System

- TPF in a future release

5.1.2 AS/400 Environment

- OS/400 Version 3 Release 1 + PTF and subsequent releases
- BRMS/400 Version 3.1 + PTF
- ADSM for OS/400 Version 1.2 + PTF
- Report/Data Archive and Retrieval System (R/DARS) for OS/400

5.1.3 RISC System/6000 and POWERparallel SP2 Environment

- AIX/6000 3.2.5 + PTF
- AIX/6000 4.1.1
- ADSM for AIX/6000 Version 1.2.1
- IBM Client Input Output/Sockets (CLIO/S)
- Remote Tape Application Interface (RTAPI) service offering
- REELibrarian Release 4.2
- NSL UniTree Release 2.1

5.1.4 Sun Environment

- SunOS 5.2 or higher releases
- Solaris 2.2 or higher releases
- ADSM for Sun Solaris

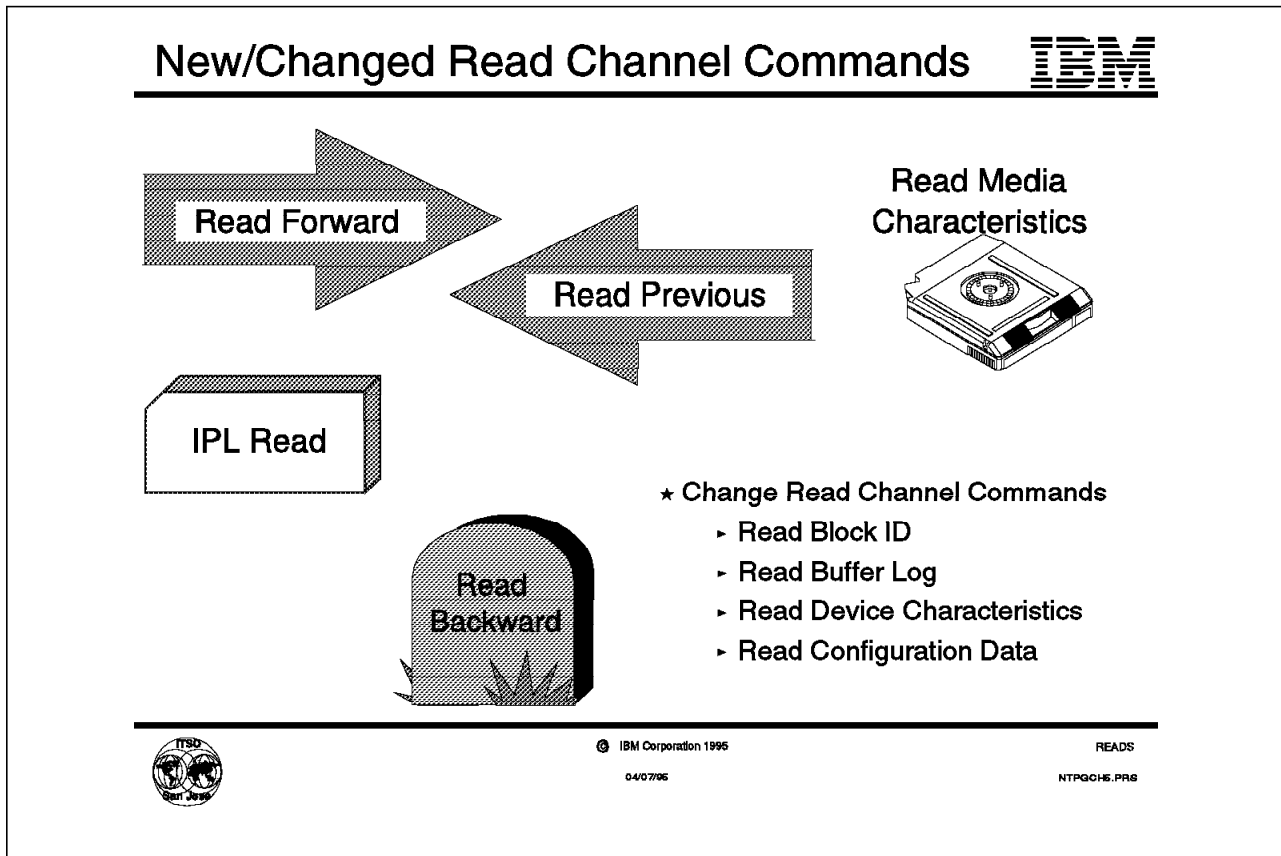

Figure 43. IBM 3590 Channel Command for ES/9000 and S/390 Systems

5.2 New and Changed Read Channel Commands for ES/9000 and S/390 Systems

Magstar Tape Drive itself is a SCSI device and has its own set of SCSI commands. The tape drive must be controlled by the SCSI commands, but the System/390 and System/370 use their own set of I/O commands to control attached I/O devices. The I/O commands that the S/390 and S/370 use are called *channel commands*, *channel command words (CCWs)*, or *channel programs*. The S/390 or S/370 channel commands differ from the SCSI commands from an architecture point of view, even though they both control I/O devices. To use the Magstar tape drive from an ES/9000 or S/390 system, an IBM 3590-A00 tape controller is required to convert the channel commands to corresponding SCSI commands. Below we describe the channel commands that are used by ES/9000 and S/390 systems.

5.2.1 Separate Channel Commands for IPL Read and Normal Read

On IBM 3480/3490 tape devices there is only one Read Forward CCW, the X'02' command code. This CCW is used to perform not only normal read operations but also an IPL Read from tape, for example, DFSMSdss Stand-Alone Restore. When the CCW is used as an IPL Read, it is not subject to resetting event notification, by definition. Because there is only one Read Forward CCW, it cannot be subject to resetting event notification on IBM 3480 and 3490 devices.

To differentiate between an IPL Read and a normal read forward operation, the X'02' command code has been redefined to be the **IPL Read** CCW, and a new X'06' command code has been defined to be the **Read Forward** CCW. The new Read Forward CCW, X'06', is subject to resetting event notification, as should be the case for normal read CCWs issued by applications or other host software.

5.2.2 Read Previous to Replace Read Backward

The ESCON-attached Magstar tape drive does not support the Read Backward CCW (command code, X'0C'). It supports a new **Read Previous** CCW that allows processing of an IBM 3590 High Performance Tape Cartridge in the backward direction without the performance penalties that exist with the Read Backward CCW. IBM 3480 and 3490 devices had to reread the physical block from the medium for each request of a logical block. The Magstar tape drive retains the physical block in the device buffer and satisfies any subsequent Read Previous from the buffer, similar to how Read Forward operates. The Read Previous CCW operates somewhat like the Read Backward CCW in that it can be used to process the volumes in the backward direction. It is different from the Read Backward, however, because the data is transferred to the host in the same order in which it was written, rather than in reverse order like Read Backward.

The DFSMS/MVS tape error recovery procedure (ERP) program for the IBM 3590 tape device has been enhanced to change a rejected Read Backward CCW to a Read Previous CCW and vice versa, where appropriate. See Section 5.6.3, "Error Recovery Procedure for IBM 3590 Tape Drive" on page 105 for details.

5.2.3 New Read Media Characteristics

The new **Read Media Characteristics** CCW (command code x'62') provides up to 256 bytes of information about the media and formats supported by the Magstar tape drive.

5.2.4 Changed Read Commands

- **Read Block ID** CCW (command code x'22') has been modified to handle the new format of the block ID. For more information, see Section 5.4, "Logical Block Numbers" on page 100.
- **Read Buffered Log** CCW (command code x'24') transfers the new format of log data which is increased to 128 bytes.
- **Read Device Characteristics** CCW (command code x'64') supports the Magstar tape drive and IBM 3590-A00 tape control unit.
- **Read Configuration Data** CCW (command code X'FA') supports the Magstar tape drive and IBM 3590-A00 tape control unit as well as some field changes.

For more detailed information about new and changed commands see the *IBM 3590 High Performance Tape Subsystem Hardware Reference*, GA32-0331.

New STAGE Channel Command



- **Stage orders**
 - ◆ Unload
 - ◆ Load
 - ◆ Move
 - ◆ Read Cell Status
 - ◆ Read Volume Loader Data

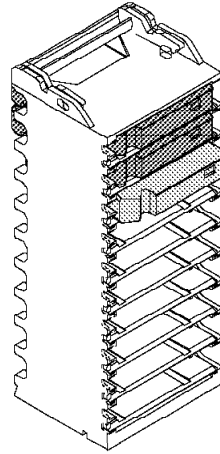

© IBM Corporation 1995
04/08/95

STAGE
NTPQCHS.PRS

Figure 44. New STAGE Channel Command

5.3 New STAGE Channel Command for ES/9000 and S/390 Systems

The new **STAGE** CCW (command code x'53') provides a mechanism to load and unload volumes on an IBM 3590-B11 tape drive and control an IBM 3590 ACF when it is operating in a mode other than library mode. The Stage CCW has several parameters called stage orders:

Stage Order	Action performed
Unload	Performs a rewind and unload of the device and returns the cartridge to the magazine as follows: <ul style="list-style-type: none">• If the ACF is operating in random mode, the cartridge is stored in a specified cell. If the cell number specified is zero, the cartridge is returned to the cell from which it was obtained when it was loaded.• If the ACF is operating in manual, accumulate, system, or automatic mode, the cartridge is stored in the first available cell in the magazine and set in the export position.
Load	Loads a cartridge in the drive as follows: <ul style="list-style-type: none">• If the ACF is operating in random mode, the cartridge is fetched from a specified cell. A cell value of zero causes a unit check.

- If the ACF is operating in system mode, the first available cartridge in the import position is loaded.

Move

Moves a cartridge from a specified source cell to a specified target cell. This order only works if the ACF is in random mode.

Read Cell Status

Returns information about the cells in the ACF. The order returns a cell type:

Type	Description
Device	The cell that is associated with the device
Storage	A cell in the magazine
Input/Output	The cell that is used to load or unload cartridges manually.

The order also returns the status, such as:

- Operational or not
- Full or empty
- Intervention required, that is, cartridge in export position.

Read Volume Loader Data Returns information about the ACF itself. The information returned is:

- Mode of operation
- Volume loader locked or not
- Volume loader status
- Number of each cell type.

When the ACF is installed within an IBM 3495 Tape Library Data Server it is controlled by the Library Manager. For more information on the ACF see Chapter 3, "IBM 3590 Automatic Cartridge Facility Operations" on page 39.

Note: Any MVS/ESA or DFSMS/MVS components that support the IBM 3590 High Performance Tape Subsystem do not use the IBM 3590 ACF *random mode*, which is managed by the Stage CCW.

Logical Block Numbers

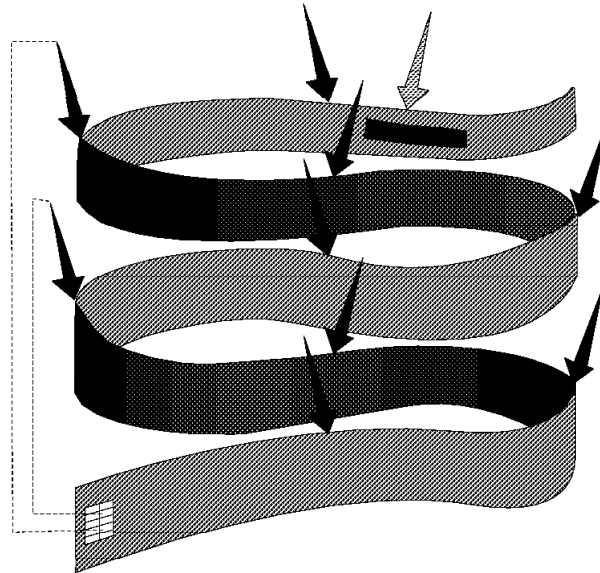

© IBM Corporation 1995
02/01/95

LBN
NTPG.PRS

Figure 45. Logical Block Number

5.4 Logical Block Numbers

This topic applies to both ESCON-attached and SCSI-attached Magstar tape drives.

The definition of block IDs for the 3480 and 3490 is as follows:

Bits	Used for
0	Direction bit
1-7	Segment number
8-9	Format
10-31	Logical block number

The Magstar tape drive uses 32 bits for block numbering in combination with a block identifier table recorded in a reserved area at the beginning of the tape. When the Magstar tape drive writes to an IBM 3590 High Performance Tape Cartridge, the block ID of the blocks written to the middle of a pass and at the end of the pass (the arrows in Figure 45) are recorded in the block table. The last block written is also recorded. The table is used to move quickly and directly to the right block in response to high-speed search requests from applications such as ADSM, DFSMSHsm, and BRMS/400.

Note: Figure 45 is not a physical representation of the tape but a logical view of the tape data.

IBM 3590 Support for MVS/ESA



- MVS/ESA SP 4.3.0, 5.1.0, or 5.2.0 Basic Control Program
- Hardware configuration definition (HCD) support only
 - ◆ MVSCP does not support the IBM 3590
- Stand-alone dump (SADMP) program
- New generic unit name: 3590-1
- Device support
 - ◆ UCCTYPE x'78048083'
 - ◆ Missing interruption handler (MIH)
 - ◆ Device class extension (DCE) increase of 40 bytes
 - ◆ Control unit initiated reconfiguration (CUIR)
 - ◆ Service information message (SIM)
 - ◆ Media information message (MIM)
- Dynamic allocation - SVC 99
- SMF type 21



© IBM Corporation 1995

04/08/95

NTPQCHE.PRS

Figure 46. IBM 3590 Support for MVS/ESA

5.5 IBM 3590 Support for MVS/ESA

The IBM 3590 support is provided as a small programming enhancement (SPE) to the MVS/ESA basic control program (BCP), JES3 component, and DFSMS/MVS 1.2.0. Below we describe the IBM 3590 support provided by the MVS/ESA BCP. The supported MVS/ESA BCPs are MVS/ESA SP 4.3.0, 5.1.0, and 5.2.0.

5.5.1 Hardware Configuration Definition

To define the existence of the IBM 3590 High Performance Tape Subsystem, users must use a hardware configuration definition (HCD) program. MVSCP does not support defining IBM 3590 devices in the MVS/ESA system.

5.5.2 Stand-Alone Dump Program

The stand-alone dump program (SADMP) allows users to use an IBM 3590 device as either the SADMP IPL device or dump output device. If users specify the COMPACT=YES option (default is YES) of the AMDSADMP macro to generate the SADMP, the dump program dumps the data with compression. This is similar to current IBM 3480 and 3490 tape devices.

5.5.3 New Generic Unit Name

3590-1 is the new generic unit name used for the Magstar tape drive in the JCL, HCD dialog, and on different ISMF panels. The 3590-1 generic unit name is incompatible with all other tape devices.

In the new default device preference table, the position of the IBM 3590 device is as follows:

1. 3590-1
2. 3490
3. 3480.

5.5.4 Device Support

The IBM 3590 device support in the BCP is described as follows:

- **UCBTYPE**

The UCBTYPE is `x'78048083'`, the OBR identifier is `X'83'`, and the MDR identifier is `X'46'`.

- **Missing interrupt handler**

The IBM 3590 device returns recommended missing interrupt handler (MIH) timeout values to the host operating system in Read Configuration Data CCW; that is, issued at IPL or VARY ONLINE processing time. It should not be necessary for customers to specify MIH timeout values for IBM 3590 devices in the IECIOSxx member of SYS1.PARMLIB because the device-supplied values should handle all MIH timeouts.

- **Device class extension**

The device class extension (DCE) control block has been increased by 40 bytes to accommodate new fields for IBM 3590 devices and allow downward compatibility with systems without the IBM 3590 support SPE.

In MVS/ESA 4.3 and 5.1, the increase is in SQA virtual below 16MB, and the total size depends on the number of UCBs defined. In MVS/ESA 5.2, the increase is in SQA virtual below 16MB, and the total size depends on the number of UCBs defined below 16MB.

- **Control unit initiated reconfiguration**

The IBM 3590 High Performance Tape Subsystem supports control unit initiated reconfiguration (CUIR) in order to fence a device or a device path.

CUIR makes it possible for the service representative to take devices or paths "offline for service" from the service panel. This ensures that the correct paths are taken offline when required and reduces operator involvement and possible errors. The CUIR is monitored by MVS/ESA and was introduced with the IBM 3990 DASD control unit.

- **Service information message**

The IBM 3590 Tape Drive is the first tape device to report service information messages (SIMs) data to the host system. This is similar to some DASD devices attached to ES/9000 and S/390 systems today. The SIMs provide service information for the hardware maintenance representatives as DASDs do.

MVS/ESA issues the following SIM:

```
IEA480E cuu,type,model,severity ALERT,  
SER=sssss,MC=mc,ES=es,REF=ref1-ref2-ref3
```

- **Media information message**

The IBM 3590 High Performance Tape Subsystem stores media statistics on a cartridge (for both read and write operations) every time it is used. This information is stored in a reserved area at the beginning of the tape in the same place as the block identifiers described in Section 5.4, "Logical Block Numbers" on page 100. When a failure occurs, the media statistics are used to help determine whether the failure is caused by media or hardware. The IBM 3590 High Performance Tape Subsystem notifies the host when a cartridge exceeds a certain error threshold. The IBM 3590 device is the first tape device to report media information messages (MIMs) data to the host system. The MIM is similar to some DASDs attached to ES/9000 and S/390 systems today.

MVS/ESA issues the following MIM:

```
IEA486E cuu,TVOL,severity ALERT,  
VOLUME=valid,MC=mc,ES=es,RC=rc-mid-fid
```

The MIM can be detected automatically by NetView in an MVS/ESA environment. NetView can then, if necessary, be used to issue commands, such as the DFSMSHsm RECYCLE command or the ADSM MOVE DATA command, to automatically move valid data off the failing cartridge.

For AS/400, the MIMs and SIMs are stored in the AS/400 error log.

- **Dynamic allocation**

Users of dynamic allocation (SVC 99) currently have the ability to use the DALINCHG text unit - Volume Interchange Specification - KEY = x'006F' to specify the media type and recording technology to be used for a system-managed tape library allocation. The allowable value has been updated to include MEDIA3 for the new cartridge and 128TRACK for the new recording technology of the IBM 3590 tape drive.

- **SMF type 21**

In two fields of the SMF type 21 record (Error Statistics by Volume), SMF21BRN and SMF21BWN, the number of bytes read and written, has been increased by 1 byte to accommodate the increase in size of the counter returned by the IBM 3590 control unit. The source of these two fields is stored in the UCB device class extension (DCE).

The SMF Volume Statistics Print Utility program, IFHSTATR, has been updated to format and print the updated SMF type 21 records.

IBM 3590 Support for DFSMS/MVS



- DFSMS/MVS Version 1 Release 2.0 or later releases
- Toleration PTFs are required for DFSMS 1.1.0 and 1.2.0
- Support both stand-alone and library environments
 - ◆ No BTLS support at GA time
- Error Recovery Procedure
 - ◆ Read alternate recovery
- Sequential Access Method
 - ◆ NOTE macro with TYPE=ABS parameter
- Checkpoint/Restart
- OPEN/CLOSE/EOV



© IBM Corporation 1995

04/10/95

NTPQCH5.PRG

Figure 47. IBM 3590 Support for DFSMS/MVS: Basic

5.6 IBM 3590 Support for DFSMS/MVS

The IBM 3590 support SPE can be installed on DFSMS/MVS 1.2.2 or subsequent DFSMS/MVS releases.

DFDSS V2.5 does not support the IBM 3590 High Performance Tape Subsystem, but DFSMSdss does.

Note: DFSMS/MVS does not use the IBM 3590 ACF random mode.

5.6.1 Toleration PTFs

Toleration PTFs will be required for DFSMS/MVS 1.1.0 and DFSMS/MVS 1.2.0 without the SPE when sharing an IBM 3494 or 3495 Automated Tape Library Dataserver with DFSMS/MVS 1.2.0 with the SPE installed.

5.6.2 Supports Both Stand-Alone and Library Environment

DFSMS/MVS 1.2.0 plus an SPE supports the IBM 3590 High Performance Tape Subsystem in both stand-alone and tape library environments. At general availability of the ESCON-attached IBM 3590 High Performance Tape Subsystem, there is no BTLS support for the IBM 3590.

5.6.3 Error Recovery Procedure for IBM 3590 Tape Drive

The tape error recovery procedure (ERP) program has been extensively changed for the new hardware. A new module, IGE0003E, has been created to support the IBM 3590 High Performance Tape Subsystem. This ERP has many functions, such as all device error recovery processing not performed by the hardware subsystem, the initiation of operator messages, logging error records, any required repositioning, and retry or restart of the failing channel program. But here we only describe the *read alternate recovery* (RAR) function because it simulates the Read Backward CCW that is not supported by the ESCON-attached IBM 3590 tape device. The RAR provides compatibility of user programs that use the Read Backward CCW to current tape device. Without any changes the user programs can use the new IBM 3590 High Performance Tape Subsystem. Note, however, that the programs that use the Read Backward CCW have to pay some performance penalty.

When this recovery action is presented for a Read Backward CCW, the ERP must issue a Read Previous CCW in order to retrieve the data from tape. Conversely, when this recovery action is presented for a Read Previous CCW, the ERP must issue a Read Backward CCW to retrieve the data from tape. The IBM 3590 devices only request a Read Alternate Recovery action if the original failing CCW was a Read Backward CCW because IBM 3590 devices do not support the Read Backward CCW. The ERP must be prepared to handle both scenarios, however, because future devices may support the Read Backward CCW. The Read Alternate Recovery action is similar to the existing Read Opposite Recovery (ROR) procedure in the 3480 and 3490 ERP. The Read Alternate Recovery procedure performs in a manner consistent with 3480 and 3490 ROR recovery. In particular, the data is read into ERP storage first and then transferred to the user's storage in much the same manner as is used today during 3480 and 3490 ROR. A Read Backward CCW's data address points to the end of the storage area, and a Read Previous CCW's data address points to the beginning of the storage area.

The tape ERP will handle incorrect length, simulate channel protection checks as required, and provide all of the checking that is done today when recovering with ROR. Note that, unlike ROR, no repositioning of the tape is required after the Read Previous CCW completes.

5.6.4 Sequential Access Method

The sequential access method (SAM) provides support for the IBM 3590 tape device. This support is functionally transparent to the user programs with the exception of those applications that use the NOTE TYPE=ABS macro and calculate the logical block number on the basis of the values returned in register 0 and register 1. These application programs may have to be modified. The IBM 3590 tape drive uses 32-bit logical block number that was in the low-order 20 bits of the registers for previous tape devices. (See Section 5.4, "Logical Block Numbers" on page 100.)

The relative block number field from the SYNADAF macro has been expanded to hold the ten decimal digits that result from the increased media capacity of the new devices.

The SAM uses the new Read Forward CCW (x'06') for the IBM 3590 tape device.

The ESCON-attached IBM 3590 tape device does not support the Read Backward CCW. When the Read Backward CCW is issued to an IBM 3590 tape device, the device returns a unit check, which causes ERP to do a Read Alternate Recovery procedure to read the data block. (See Section 5.6.3, “Error Recovery Procedure for IBM 3590 Tape Drive” for more details.) This results in a performance penalty for programs processing SAM tape data sets open for RDBACK on the IBM 3590 devices.

5.6.5 Checkpoint/Restart

Restart issues the new Read Previous CCW instead of the Read Backward CCW to the IBM 3590 tape device.

5.6.6 Open/Close/End-of-Volume

OPEN/CLOSE/EOV routines in DFSMS/MVS have been changed to record the serial number of the physical Magstar tape drive used to write a data set. This device serial number is stored in bytes 42-47 in the HDR2/EOV2/EOF2 headers.

- **System-Managed Storage (SMS)**
 - ◆ Data class
 - ▶ New recording technology 128TRACK
 - ▶ New media type MEDIA3
 - ◆ Storage group
 - ◆ Automatic class selection (ACS) routines
- **Access Method Services (AMS) command changes**
 - ◆ ALTER, CREATE, LISTCAT
 - ▶ LIBRARYENTRY, VOLUMEENTRY
 - ▶ New media type and recording technology



Figure 48. IBM 3590 Support for DFSMS/MVS: SMS and AMS

5.6.7 System-Managed Storage

The new IBM 3590 tape device introduces a new media type, recording technology, and device type. Defining or altering the existing SMS constructs and definitions may be required.

- **Data class**

The only way to specify which type of media to use for a data set is to select a data class (DC), either directly in the JCL or indirectly by using the ACS routines. A new Data Class Definition/Alteration panel has been defined for media interchange and compaction. This information was specified on Panel 2 in previous releases of DFSMS/MVS. The data class panel of DFSMS/MVS has also been enhanced to offer two new choices for media type:

- **MEDIA3**, to specify the IBM 3590 High Performance Tape Cartridge
- MEDIA4, reserved for future use.

For the new media types, a new recording technology of **128TRACK** can be specified. Other ISMF panels and displays have been updated with the option of specifying and/or displaying the new device type, 3590-1, and the two new media types, MEDIA3 and MEDIA4, but MEDIA4 is reserved for future use.

Note: The above description applies only to System Managed Tape (SMT) in DFSMS/MVS. The IBM 3590 is of course supported outside SMT, but there is no way to select the media type outside SMT.

- **Storage group**

To use the new IBM 3590 devices, system programmers may need to create or alter existing storage group constructs.

- **Automatic class selection routines**

To use the new IBM 3590 devices, existing customer-written automatic class selection (ACS) filter routines may have to be changed or new ACS routines created to select the appropriate SMS constructs.

5.6.8 Access Method Services Command Changes

ALTER, CREATE, and LISTCAT Access Method Services (AMS) commands have been changed to support the new media type and recording technology.

One new subparameter, 128TRACK, for the RECORDING parameter has been added for the CREATE and ALTER VOLUMEENTRY commands. Another new subparameter, MEDIA3, for the MEDIATYPE parameter has been added for the CREATE and ALTER VOLUMEENTRY commands.

```
CREATE VOLUMEENTRY
  (NAME(entryname)
   RECORDING(128TRACK)
   MEDIATYPE(MEDIA3)
  )
```

```
ALTER entryname VOLUMEENTRY
  RECORDING(128TRACK)
  MEDIATYPE(MEDIA3)
```

The number of scratch volumes and the threshold value for the new media type MEDIA3 subparameter have been added to the CREATE and ALTER LIBRARYENTRY commands.

```
CREATE LIBRARYENTRY
  (NAME(entryname)
   NUMBERSCRATCHVOLUMES(MEDIA1(num) MEDIA2(num)
                        MEDIA3(num))
   SCRATCHTHRESHOLD(MEDIA1(num) MEDIA2(num)
                    MEDIA3(num))
  )
```

```
ALTER entryname LIBRARYENTRY
  NUMBERSCRATCHVOLUMES(MEDIA1(num) MEDIA2(num)
                        MEDIA3(num))
  SCRATCHTHRESHOLD(MEDIA1(num) MEDIA2(num)
                   MEDIA3(num))
```

The LISTCAT command has been enhanced to display the value associated with the MEDIATYPE and RECORDING parameters for volume entries and the NUMBERSCRATCHVOLUMES and SCRATCHTHRESHOLD for library entries.

- **Interactive Storage Management Facility (ISMF)**
 - ◆ Media type (MEDIA3) and recording technology (128TRACK)
 - ◆ Scratch threshold and number of scratch volumes for MEDIA3
 - ◆ Data Set, Tape Library, Data Class, Mountable Tape Volume application panels have been changed
- **DFSMSHsm**
 - ◆ New 3590 unittype (3590-1) in all DFSMSHsm commands
- **DFSMSrmm**
 - ◆ RMM TSO subcommand
 - ▶ New media type (MEDIA3) and recording technology (128TRACK)
 - ▶ ADDVOLUME, CHANGEVOLUME, LISTVOLUME, SEARCHVOLUME



Figure 49. IBM 3590 Support for DFSMS/MVS: ISMF, DFSMSHsm, and DFSMSrmm

5.6.9 Interactive Storage Management Facility

On the Interactive Storage Management Facility (ISMF) dialog panels, a new generic device type, **3590-1**, is used for the IBM 3590. The new media type, MEDIA3, and recording technology, 128TRACK, subparameters are also used. The scratch threshold value and number of the scratch volumes for MEDIA3 also have been added. The following ISMF panels have been updated to support the IBM 3590:

- Data set application
 - Data Set Selection Entry
 - Data Set List
 - Data Set Filter Entry
- Tape library application
 - Tape Library Define
 - Tape Library Alter/Redefine
 - Tape Library Display
 - Tape Library List
 - Tape Library View Entry
 - Tape Library Sort Entry
- Data class application
 - Data Class Define/Alter
 - Data Class Display
 - Data Class List

- Mountable tape volume application
 - Mountable Tape Volume List

5.6.10 Hierarchical Storage Manager (DFSMSHsm)

DFSMSHsm supports the new IBM 3590 tape device for all user commands that specify a tape device. Table 7 lists all of the DFSMSHsm commands that are affected. The value of *unittype* for the IBM 3590 tape device is **3590-1**.

<i>Table 7. DFSMSHsm User Commands Affected by IBM 3590 Support</i>		
Command	Required Parameter	Optional Parameter
ABACKUP		UNIT(<i>unittype</i>)
ADDVOL	UNIT(<i>unittype</i>)	
ARECOVERY		UNIT(<i>unittype</i>)
BACKDS		UNIT(<i>unittype</i>)
DEFINE		UNIT(<i>unittype</i>)
MIGRATE		UNIT(<i>unittype</i>)
RECALL		UNIT(<i>unittype</i>)
RECOVER		UNIT(<i>unittype</i>)
SETSYS		ABARSUNITNAME(<i>unittype</i>)
SETSYS		ARECOVERML2UNIT(<i>unittype</i>)
SETSYS		ARECOVERUNITNAME(<i>unittype</i>)
SETSYS		BACKUP(TAPE(<i>unittype</i>))
SETSYS		CDSVERSIONBACKUP UNITNAME(<i>unittype</i>)
SETSYS		MIGUNITNAME()
SETSYS		RECYCLEOUTPUT (BACKUP(<i>unittype</i>) MIGRATION(<i>unittype</i>))
SETSYS		SPILL(TAPE(<i>unittype</i>))
SETSYS		TAPEMIGRATION(DIRECT(TAPE(<i>unittype</i>)) ML2TAPE(TAPE(<i>unittype</i>)) NONE(ROUTETOTAPE(<i>unittype</i>)))
SETSYS		TAPEUTILIZATION UNITNAME(<i>unittype</i>)
SETSYS		UNITNAME(<i>unittype</i>)
TAPECOPY		ALTERNATEUNITNAME(<i>unittype1,unittype2</i>)
TAPEREPL		ALTERNATEUNITNAME(<i>unittype</i>)

5.6.11 Removable Media Manager (DFSMSrmm)

The removable media manager component, **DFSMSrmm**, has been enhanced to support the IBM 3590 tape device.

The RMM TSO ADDVOL, CHANGEVOL, and SEARCHVOL subcommands have a new value in the MEDIATYPE and RECORDINGFORMAT parameters for the IBM 3590. The new value for MEDIATYPE is **3590** and for RECORDINGFORMAT, **128TRACK**.

The output of LISTVOLUME commands for the IBM 3590 show the following new values:

3590 An IBM 3590 High Performance Tape Cartridge

128TRACK Specifies the recording format for the IBM 3590

In other places within the DFSMS/MVS program product where tape or media can be selected or displayed (for example, in the IDCAMS utility), new values, such as 3590, 3590-1, or MEDIA3, can be chosen or used.

IBM 3590 Support for DFSMS/MVS



- **Object Access Methods - basic device support**
 - ◆ Object tape support
 - ◆ OAM optical configuration database
 - ◆ CBROAMxx SYS1.PARMLIB member
 - ▶ TAPEUNIT and new DEMOUNTWAITTIME parameter
- **Tape Library Support - Library Control System (LCS)**
 - ◆ Tape configuration database (TCDB)
 - ▶ Tape library record
 - ▶ Tape volume record
 - ◆ LCS external services
 - ▶ Tape device selection information (TDSI)
 - ▶ CBRXLCS macro



© IBM Corporation 1995

04/08/95

NTPQCHS.PRS

Figure 50. IBM 3590 Support for DFSMS/MVS: OAM and LCS

5.6.12 Object Access Method

Object access method (OAM) basic device support for the IBM 3590 tape device is as follows:

- **Object tape support**

This support extends the scope of the devices and media types supported by the OAM Object Tape support function introduced in DFSMS/MVS 1.2.0.

OAM allocates a scratch tape using the tape unit name specified with the TAPEUNITNAME subparameter of the STORAGEGROUP parameter on the SETOAM command. The TAPEUNITNAME parameter allows 3590-1 as a valid unit name. OAM also supports the new 3590 media type.

- **OAM optical configuration database**

OAM tape volumes that are used for object storage are tracked in a DB2 table in the OAM optical configuration database. The DB2 name of the table is TAPEVOL. The table is contained within a separate DB2 table space, ODTVLTSP.

The **OAM Tape Configuration Database** (TCDB) shows new values in the following columns:

UNITNAME	In this column 3590-1 is used for the IBM 3590 tape device										
MEDIATYP	This column contains a value that indicates the media type as follows:										
	<table border="0"> <thead> <tr> <th style="text-align: left;">Value</th> <th style="text-align: left;">Meaning</th> </tr> </thead> <tbody> <tr> <td>02</td> <td>This is a Standard Capacity Cartridge System Tape, CST.</td> </tr> <tr> <td>04</td> <td>This is an Enhanced Capacity Cartridge System Tape, ECCST.</td> </tr> <tr> <td>05</td> <td>This is an IBM 3590 High Performance Tape Cartridge.</td> </tr> </tbody> </table>	Value	Meaning	02	This is a Standard Capacity Cartridge System Tape, CST.	04	This is an Enhanced Capacity Cartridge System Tape, ECCST.	05	This is an IBM 3590 High Performance Tape Cartridge.		
Value	Meaning										
02	This is a Standard Capacity Cartridge System Tape, CST.										
04	This is an Enhanced Capacity Cartridge System Tape, ECCST.										
05	This is an IBM 3590 High Performance Tape Cartridge.										
CAPACITY	This column contains the approximate number of millimeters of the tape as well as the approximate number of kilobytes of data for the volume. The values are as follows:										
	<table border="0"> <thead> <tr> <th style="text-align: left;">Value</th> <th style="text-align: left;">Meaning</th> </tr> </thead> <tbody> <tr> <td>150,000</td> <td>This is the length of a CST, written in 18-track format on an IBM 3480 or 3490 base model.</td> </tr> <tr> <td>300,000</td> <td>This is the length of a CST, written in 36-track format on an IBM 3490E.</td> </tr> <tr> <td>600,000</td> <td>This is the length of an ECCST, written in 36-track format on an IBM 3490E.</td> </tr> <tr> <td>9,765,625</td> <td>This is the approximate number of kilobytes of data for an IBM 3590 High Performance Tape Cartridge.</td> </tr> </tbody> </table>	Value	Meaning	150,000	This is the length of a CST, written in 18-track format on an IBM 3480 or 3490 base model.	300,000	This is the length of a CST, written in 36-track format on an IBM 3490E.	600,000	This is the length of an ECCST, written in 36-track format on an IBM 3490E.	9,765,625	This is the approximate number of kilobytes of data for an IBM 3590 High Performance Tape Cartridge.
Value	Meaning										
150,000	This is the length of a CST, written in 18-track format on an IBM 3480 or 3490 base model.										
300,000	This is the length of a CST, written in 36-track format on an IBM 3490E.										
600,000	This is the length of an ECCST, written in 36-track format on an IBM 3490E.										
9,765,625	This is the approximate number of kilobytes of data for an IBM 3590 High Performance Tape Cartridge.										
FRESpace	Contains the available free space, in kilobytes, left for writing data on the volume. For MEDIATYPes 02 and 04, this value is kilobytes (KB), 05 is in megabytes (MB).										

- **CBROAMxx SYS1.PARMLIB member**

OAM processes the CBROAMxx SYS1.PARMLIB member during OAM address space initialization. The CBROAMxx member of SYS1.PARMLIB contains the SETOAM command. The TAPEUNITNAME parameter of the SETOAM command in the CBROAMxx member accepts the new unit name for the IBM 3590 tape device. **3590-1** is a valid generic unit name for the IBM 3590.

A new optional parameter, DEMOUNTWAITTIME, has been added to specify the amount of time OAM waits before demounting and deallocating a tape device. This parameter is applicable for all tape devices that OAM supports. The value specified is the time in seconds; the default is 120 sec.

5.6.13 Tape Library Support

OAM tape library support routines, library control system (LCS), have been updated to support the IBM 3590 High Performance Tape Subsystem in the IBM Automated Tape Library Dataservers.

- **Tape configuration database**

To accommodate the new media type and recording technology, the library record and volume record in the tape configuration database (TCDB) have been changed. To share a TCDB with lower-level DFSMS/MVS systems that do not support the IBM 3590 tape drive, toleration PTFs to the lower-level systems are required. The number of scratch volumes and scratch volume message threshold fields in the new MEDIA3 subparameter have been

modified in the tape library record. The new tape recording technology (128TRACK) and media type (MEDIA3) for the IBM 3590 can be set in the tape volume record.

- **LCS external services**

LCS external services provided by the CBRXLCS macro have been changed to support the new media type and recording technology.

Tape device selection information (TDSI), mapped by the CBRTDSI macro, is used to pass device selection information among system components providing the tape library support. The TDSI now contains the definitions of the new media type (MEDIA3) and recording technology (128TRACK). Source code for CBRTDSI is distributed in SYS1.MACLIB.

- **Tape Library Support - LCS ... continued ...**
 - ◆ **Installation exits**
 - ▶ Change use attribute exit - CBRUXCUA
 - ▶ Cartridge entry exit - CBRUXENT
 - ▶ Cartridge eject exit - CBRUXEJC
 - ▶ Volume not in library - CBRUXVNL
 - ◆ **Operator commands**
 - ▶ DISPLAY SMS,LIBRARY(library-name),DETAIL
 - ▶ DISPLAY SMS,VOLUME(volser)
 - ▶ LIBRARY DISPDRV
 - ▶ LIBRARY DISPCL
 - ▶ LIBRARY SETCL
 - ◆ **Sharing a TCDB with lower-level systems**
 - ▶ Tape cartridge entry
 - ▶ Tape cartridge eject
 - ▶ Tape volume audit
 - ▶ Volume not in library



Figure 51. IBM 3590 Support for DFSMS/MVS: LCS (continued)

- **Installation exits**

The new TDSI values, MEDIA3 and 128TRACK, are passed to the following installation exit routines:

- Change use attribute exit - CBRUXCUA
- Cartridge entry exit - CBRUXENT
- Cartridge eject exit - CBRUXEJC
- Volume not in library exit - CBRUXVNL.

Customer-written exit routines must be reviewed and changed to use the IBM 3590 High Performance Tape Subsystem. See the *DFSMS/MVS Version 1 Release 3 Object Access Method Planning, Installation, and Storage Administration Guide for Tape Libraries*, SC26-3051, for details.

- **Operator commands**

The following operator commands support the new media type and recording technology:

- **DISPLAY SMS,LIBRARY(library-name),DETAIL**

Displays scratch volume counts and their corresponding scratch threshold values for the new media type. The command displays scratch volume counts for only those media types that have a scratch threshold value and a scratch count greater than zero.

- **DISPLAY SMS,VOLUME(volser)**

Displays the new media type and recording technology.

- **LIBRARY DISPDRV**

Used to display the new media type for scratch volumes that are in the cartridge loader for the tape library.

- **LIBRARY DISPCL**

Used to display the new media type for scratch volumes that are in the cartridge loader for the IBM 3495 Automated Tape Library Dataserver. The display output for the DSIPCL is same as the DISPDRV output for a single drive.

- **LIBRARY SETCL**

Sets the new media types for scratch volumes that will be loaded into the cartridge loader of a tape drive inside the IBM 3495 Automated Tape Library Dataserver. The devices in an IBM 3494 Automated Tape Library Dataserver currently have no cartridge loader. If the SETCL command is issued, the command fails.

- **Sharing a TCDB with lower-level systems**

In an environment with multiple systems at different DFSMS/MVS software levels but sharing a common TCDB that has up-level TDSI values, users must be aware of the following processing:

- Tape cartridge entry processing

When cartridges are entered into an IBM automated Tape Library Dataserver, the Library Manager sends an unsolicited attention interrupt to all connected systems to signal that cartridges are in the insert category. When the new IBM 3590 High Performance Tape Cartridge is entered in the library, the attention interrupt could be sent to a DFSMS/MVS system that does not support or understand the new media type. The lower-level software system is changed to recognize this condition by the toleration PTF and leave the up-level volumes in the insert category. Insert processing for the new IBM 3590 High Performance Tape Cartridge must be done by a host system that supports the up-level media type.

- Tape cartridge eject processing

A MEDIA3 volume can only be rejected from a system that understands the new media type. If an eject request for an up-level volume is submitted by a lower-level software system, the eject request fails.

- Tape volume audit processing

The library audit must be performed on the system with the highest software level of DFSMS/MVS because the lower-level software system cannot include the new media type.

- Volume not in library installation exit processing

If a job run on a lower-level software system inadvertently asks for a MEDIA3 volume, the exit has two choices: cancel the job or proceed to have the volume entered. If the exit proceeds to have the volume entered, once the volume is successfully entered on an up-level system and the exit returns with return code 4 (indicating retry), the job on the lower-level system fails during job step setup on subsequent retrieval of the volume record. If the host system detects that it is an up-level volume (TCDB volume record exists), the call to the exit is bypassed, and the job is canceled.

IBM 3590 Support for JES3



- JES3 component Version 4.2.1, 5.1.1 or 5.2.1 required
 - Library device group (LDG) name for the IBM 3590
 - ▶ LDBsssss
 - ▶ LDG3591
 - DTYPE is TA435901 for JUNIT in JES3 DEVICE card
 - JES3 Dump Job DSP supports IBM 3590
 - ▶ Can specify TA435901 or TA4 on IN= or OUT= parameter
 - Other JES3 tape DSPs do not support the IBM 3590



© IBM Corporation 1995

04/10/95

NTPQCH5.PRG

Figure 52. IBM 3590 Support for JES3

5.7 IBM 3590 Support for JES3

In a JES3 environment, JES3 component Version 4.2.1, 5.1.1, or 5.2.1 is required to use the IBM 3590 High Performance Tape Subsystem. The IBM 3590 tape device is treated as one of the tape devices supported by JES3.

5.7.1 Library Device Group Name

To use the IBM 3590 devices in a JES3-managed IBM Automated Tape Library Dataserver, the following esoteric unit names must be defined as library device group (LDG) names in the HCD and SETNAME of the JES3 initialization parameter:

- LDBsssss - includes any IBM 3590 within the library indicated by library serial number, sssss.
- LDG3591 - includes any IBM 3590 in any library in the JES3plex.

5.7.2 DTYPE for JUNIT

When IBM 3590 tape devices are used as JES3-managed devices, they must be defined on DEVICE statements in the JES3 initialization parameter. If the JUNIT parameter is specified in the DEVICE statement, the DTYPE must be specified as **TA435901**.

5.7.3 JES3 Dump Job Dynamic Support Program

The JES3 Dump Job (DJ) Dynamic Support Program (DSP) supports the IBM 3590 tape device for dumping and restoring the JES3 spool. When the operator calls the Dump Job DSP, TA435901, TA4, or the device number can be specified on the IN= or OUT= parameter in the JES3 CALL,DJ command. The operator can also specify compaction.

5.7.4 Other JES3 Tape Dynamic Support Program

The other JES3 tape DSPs, such as TT (Tape to Tape) and TL (Tape Label), do not support the IBM 3590 device.

VM/ESA Version 2



- IBM 3590 support is same as for 3480, 3490, and 3490E
- CP
 - ◆ Guest operating system support
 - ◆ DDR
 - ◆ SPXTAPE
 - ◆ Stand-alone DUMP
 - ◆ MONITOR, TRSAVE
- CMS
 - ◆ Commands
 - ▶ TAPE, VMFPLC2, FILEDEF, ASSGN
 - ◆ Assembler macros
 - ▶ RDTAPE, WRTAPE, TAPECTL, TAPESL
- DFSMS/VM RMS



© IBM Corporation 1995

04/10/95

NTPQCH5.PRG

Figure 53. VM/ESA Version 2

5.8 VM/ESA Version 2

VM/ESA Version 2 supports the IBM 3590 High Performance Tape Subsystem in both VM/ESA native and guest operating system environments. The IBM 3590 High Performance Tape Subsystem is also supported in the IBM Automated Tape Library Dataservers.

5.8.1 CP

CP provides basic device support such as device type definition and recognition, CCW translation, and error recovery procedures.

CP converts the Read IPL CCW (x'02') to the Read Forward CCW (x'06') for the IBM 3590 tape drive when the I/O is issued by DIAGNOSE or CP I/O. The CP IPL command also has been modified to use the Read Forward CCW if the device is an IBM 3590 tape drive.

- **Guest operating system support**

To provide guest operating system support, the CP has enhanced the CCW translation to handle the new and changed CCWs that are used by the IBM 3590 High Performance Tape Subsystem. The guest operating systems that support the IBM 3590 High Performance Tape Subsystem can use the tape subsystem in the same way as in its native environment.

- **DDR**

The DASD Dump Restore (DDR) utility program supports the IBM 3590 tape device. The specified device type for the IBM 3590 in the DDR control statement is "3590". Both stand-alone DDRXA program and CMS command DDR support the IBM 3590.

- **SPXTAPE**

SPXTAPE is a CP utility that dumps and restores CP spool files to and/or from tape devices. SPXTAPE supports the IBM 3590 tape device and uses the Read Forward CCW if the tape device is an IBM 3590.

- **Stand-alone dump**

The stand-alone dump program recognizes the IBM 3590 tape device as a valid IPL and dump device.

- **MONITOR and TRSAVE**

The format of the MONITOR and TRSAVE commands has not changed but the IBM 3590 tape drive is supported.

5.8.2 CMS

CMS commands and macros support the IBM 3590 High Performance Tape Subsystem as a tape device.

- **Commands**

TAPE, VMFPLC2, and FILEDEF CMS commands support the IBM 3590 tape device. Two new options of the CMS commands are available for the IBM 3590 device:

- 3590B - specifies uncompact recording format
- 3590C - specifies compacted recording format.

- **Assembler macros**

CMS assembler macros, RDTAPE, WRTAPE, TAPECTL, and TAPESL, support the IBM 3590 tape device. Two new values of the MODE= parameter in each macro have been provided:

- 3590B - specifies uncompact recording format
- 3590C - specifies compacted recording format.

5.8.3 DFSMS/VM Removable Media Services

DFSMS/VM Removable Media Services (RMS) virtual machine and its interface routines provide support for the IBM Automated Tape Library Dataservers. The IBM 3590 tape devices can be used in the IBM 3494 and 3495 Automated Tape Library Dataservers. The DFSMS/VM RMS has been enhanced to recognize the new IBM 3590 tape device and the new IBM 3590 High Performance Tape Cartridge.

5.9 VSE/ESA Version 2

VSE/ESA Version 2 will support the IBM 3590 High Performance Tape Subsystem in the fourth quarter of 1996. EREP 3.5.0 plus PTF, DITTO/ESA Release 1, and future release of ADSM for VSE will also support the IBM 3590 High Performance Tape Subsystem.

5.10 Transaction Processing Facility (TPF)

TPF Version 4.1 supports the IBM 3590 High Performance Tape Subsystem.

OS/400 Version 3 Release 1



- **OS/400 Version 3 Release 1 + PTF**
 - ◆ **BRMS/400 and ADSM for OS/400**
 - ▶ Support ACF random mode as tape library
 - ◆ **Alternate IPL is supported with RPQ 843860**
 - ◆ **IBM 3590 cannot be used for software distribution**
 - ▶ Use a current supported tape drive
 - ▶ Migrate to CD-ROM



© IBM Corporation 1995

04/10/95

NTPQCHS.PRG

Figure 54. OS400 Version 3 Release 1

5.11 OS/400 Version 3 Release 1

OS/400 Version 3.1 is required to use the IBM 3590 High Performance Tape Subsystem in both a tape-library and non-tape-library environment. Typically the user application program itself does not use the tape drive directly. The backup and archive software subsystems, such as Backup Recovery and Media Services/400 (BRMS/400) and ADSM for OS/400, use tape drives and tape libraries.

BRMS/400 Version 3.1 and ADSM for OS/400 support IBM 3590 High Performance Tape Subsystem. Both BRMS and ADSM can utilize an IBM 3590-B11 as a tape library by using the ACF in random mode.

If you want to use IBM 3590 tape drive for alternate IPL, RPQ 843860 is required.

The IBM 3590 tape drive cannot be used for IBM software distribution in an OS/400 environment. Please use current supported tape drive or migrate to the CD-ROM software distribution system.

AIX/6000 Version 3.2.5 and Version 4.1.1



- AIX V3.2.5 and V4.1.1

- ◆ For RISC System/6000 and POWERparallel SP2 systems
- ◆ Device driver
 - ▶ 3590-B11 - 3590 feature code 9603
 - ▶ 3590-B1A - 3494 feature code 5212
- ◆ Compatible with 3490E support
- ◆ Support ACF as medium changer
- ◆ Tape drive service aids
- ◆ Must increase SCSI adapter DMA bus memory to utilize 2MB buffer



© IBM Corporation 1995

04/06/95

NTPQCHS.PRS

Figure 55. AIX/6000 Version 3.2.5 and Version 4.1.1

5.12 AIX/6000 Version 3.2.5 and Version 4.1.1

AIX/6000 Versions 3.2.5 and 4.1.1 support the IBM 3590 High Performance Tape Subsystem in both a RISC/6000 and POWERparallel SP2 system environment.

The device driver for the IBM 3590 is provided as a hardware feature of the IBM 3590-B11 tape drive. The feature number is 9603. For library support, a feature number of the IBM 3494 tape library (number 5212) provides both the IBM 3590-B1A tape drive device driver and the Library Manager device driver. The Library Manager device driver supports both RS-232 and LAN interfaces. Both device drivers for the IBM 3590 tape drive are exactly same.

The SCSI tape device driver is called the IBM AIX Enhanced Tape Medium Changer Device Driver. The device driver supports the IBM 3490 models C and E, the IBM 3590 High Performance Tape Subsystem, and the IBM 7331 8 mm tape libraries. All current application interfaces, such as *open*, *read*, *write*, *close*, and *ioctl*, are supported. The *ioctl* application interface provides a set of tape and SCSI-specific functions. It allows an AIX/6000 application to access and control features and attributes of the tape device programmatically. For the IBM 3590 tape drive and medium devices (ACF), *ioctl* also provides a set of medium changer functions that can be accessed through the normal tape device special file or independently through an additional special file for the medium changer only.

The device driver supports standard AIX/6000 tape commands, such as *tctl*, *mt*, *dd*, *tar*, *cpio*, *backup*, and *restore*. A standard set of AIX/6000 device management commands is available. The *chdev*, *rmdev*, *mkdev*, and *lsdev* commands are used to bring the device online or change attributes that determine the status of the tape devices.

A set of Tape Drive Service Aids is provided with the device driver. The service aids can take the dump of the tape drive microcode and transfer it to the host. It is also possible to load the microcode from the host into the tape drive through a SCSI interface.

If you want to read or write 2MB block size data for the IBM 3590 tape drive, you must increase the SCSI adapter DMA bus memory length by using **smit config**. The default block size is 256KB.

Device driver information is described in the *IBM SCSI Tape Drive, Medium Changer, and Library Device Drivers Installation and User's Guide*, GC35-0154.

- SunOS Release 5.2 or 5.3 and Solaris Release 2.2 or 2.3
 - ◆ Device driver
 - ▶ 3590-B11 - 3590 feature code 9710
 - ▶ 3590-B1A - 3494 feature code 9204
 - ◆ Compatible with 3490E support
 - ◆ Support ACF as medium changer
 - ◆ Tape drive service aids
 - ◆ 256KB block size limitation due to SCSI adapter



Figure 56. SunOS and Solaris

5.13 SunOS and Solaris

The IBM 3590 support for SunOS and Solaris is similar to the IBM 3590 support for AIX/6000. SunOS 5.2 or 5.3 and Solaris 2.2 or 2.3 support the IBM 3590 High Performance Tape Subsystem on Sun systems.

The IBM 3590 device driver for SunOS is provided as a hardware feature of the IBM 3590-B11 tape drive. The feature number is 9710. For library support, a feature number of IBM 3494 (number 9204) provides both the IBM 3590-B1A tape drive device driver and the Library Manager device driver. The Library Manager device driver supports both RS-232 and LAN interfaces. Both device drivers for IBM 3590 tape drive are exactly same.

The SCSI device driver contains both a tape drive and medium changer device driver. The device driver supports the IBM 3490 C and E models and the IBM 3590 High Performance Tape Subsystem. All current application interfaces, such as *open*, *read*, *write*, *close*, and *ioctl*, are supported. The *ioctl* application interface provides a set of tape and SCSI-specific functions. For the IBM 3590 tape drive and medium devices (ACF), *ioctl* also provides a set of medium changer functions.

A set of Tape Drive Service Aids is provided with the device driver. The service aids can take the dump of the tape drive microcode and transfer it to the host. It is also possible to load the microcode from the host into the tape drive through a SCSI interface.

The maximum block size of the IBM 3590 tape drive is limited to 256KB because of the SCSI adapter in the Sun system.

Device driver information is available in the *IBM SCSI Tape Drive, Medium Changer, and Library Device Drivers Installation and User's Guide*, GC35-0154.

● ADSM on RISC System/6000 and Sun Systems

- ◆ ADSM for AIX/6000
 - ▶ Version 1 Release 2.1
 - ▶ On AIX/6000 V3.2.5 or V4.1.1
- ◆ ADSM for Sun/Solaris
 - ▶ Version 1 Release 2.1
 - ▶ On SunOS Release 5.3 or Solaris Release 2.3
- ◆ Use ACF as 10-cartridge library
- ◆ Support both stand-alone and tape library environments
- ◆ Use high-speed locating facility of the IBM 3590



Figure 57. ADSM for AIX/6000 and SunOS/Solaris

5.14 ADSM for AIX/6000 and SunOS/Solaris

AdStar Distributed Storage Manager (ADSM) for AIX/6000 and ADSM for SunOS/Solaris provide support for IBM 3590 High Performance Tape Subsystem similar to the support provided for IBM 3480 and 3490 tape subsystems. The IBM 3590 support requires ADSM Version 1 Release 2.1. Supported operating system levels of AIX are AIX 3.2.5 and AIX 4.1.1. For Sun systems, SunOS 5.3 or Solaris 2.3 is required.

ADSM uses the ACF of the IBM 3590 as a 10-cartridge tape library. Thus the IBM 3590-B11 is treated as a medium change library. The 3590 tape drives in the IBM 3494 Automated Tape Library Dataserver are also supported. ADSM also uses the high-speed search capability of the IBM 3590.

- **POWERparallel SP2 and RISC System/6000**
 - ◆ IBM Client Input Output/Sockets (CLIO/S)
 - ◆ RTAPI (Remote Tape API)
 - ◆ REELibrarian for AIX/6000 Release 4.2
 - ◆ NSL Unitree



© IBM Corporation 1995

04/10/95

NTPQCH5.PRG

Figure 58. Other Software Supported for IBM 3590

5.15 Other Software Supported for IBM 3590

On the POWERparallel SP2 and RISC System/6000 systems, support for the IBM 3590 High Performance Tape Subsystem is also provided under the following products:

- **IBM Client Input Output/Sockets**

IBM Client Input Output/Sockets is a set of commands and application programming interfaces (APIs) that can be used for high-speed communication and for accessing tape devices on a network of AIX workstations and MVS/ESA mainframes. CLIO/S makes it easier to distribute work and data across a network of POWERparallel SP2, RISC/6000, and MVS/ESA mainframe systems. CLIO/S also provides an API to tape drives anywhere in the network. The API supports the IBM 3590 High Performance Tape Subsystem.

CLIO/S is a licensed program (program number 5648-129). See the *IBM Client Input Output/Sockets Version 2 Release 1 General Information*, GC23-3879, for details.

- **RTAPI**

Remote Tape Application Interface (RTAPI) is a service offering developed by the IBM Scientific and Technical Systems and Solution group. The RTAPI provides data transfer from tape servers to tape clients at near tape-head speeds.

Clients can access the tape devices on tape servers located at remote sites throughout a network. Tape server support is for IBM 3590 tape drives. The client interface is an API, not a device driver interface, so users must develop client applications.

- **REELlibrarian**

REELlibrarian for AIX/6000 Release 4.2 supports the IBM 3590 High Performance Tape Subsystem. The REELlibrarian is a tape management product developed by Storage Technology Corporation.

- **NSL UniTree**

National Storage Laboratory (NLS) UniTree Release 2.1 supports the IBM 3590 High Performance Tape Subsystem. This product is an online mass storage management system that gives users direct access to data stored on a variety of different storage devices.

Chapter 6. Tape Performance Considerations

In the absence of the final performance information relating to the IBM 3590 High Performance Tape Subsystem that uses the Magstar tape drive, this chapter discusses the 3490E performance characteristics and how they relate to effective data rate and overall performance of the 3490E subsystems. The discussion is then extended to the new Magstar tape drive devices, developing ideas and issues of most importance when considering the improvements in native drive performance available with the Magstar tape drive.

The general nature of the discussions and diagrams relates to all relevant platforms (for example, ES/9000, S/390 Parallel Server, RISC/6000, and AS/400). However, the tape performance in any subsystem will depend on the implementation, applications, and thus platform. The actual throughput a customer can achieve is a function of many components, such as system processor, disk data rate, data block size, data compressibility, I/O attachments, and system and application software.

IBM 3490E ESCON Data Rate

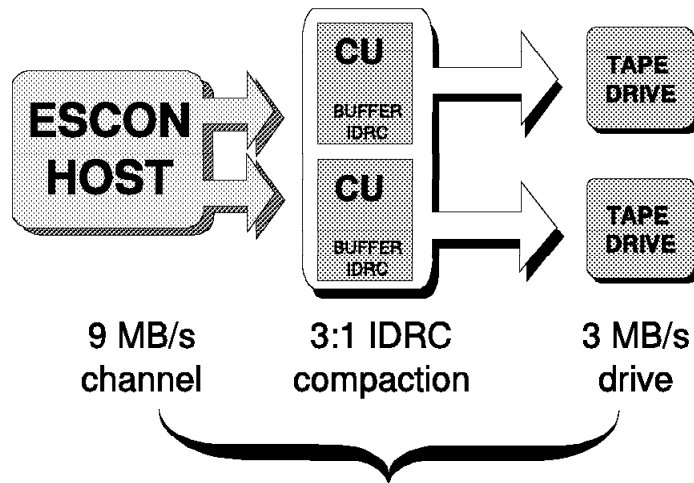

Effective data rate approximately 6MB/s per path*

*Note that effective data rate achieved is a function of many components of a system



© IBM Corporation 1995
05/12/95

CPERES1
NTPGCH8.PRS

Figure 59. IBM 3490E ESCON Data Rate

6.1 IBM 3490E ESCON Data Rate

Figure 59 shows an ESCON host attached to an IBM 3490E model A20 control unit using two ESCON channel adapters. Note that this diagram shows two channels to the control unit; the effective and instantaneous data rates quoted refer to each path. Thus the overall effective data rate in the diagram is 12MB/s for the model A20 control unit—6MB/s for each path. In the sections below, the effective (or sustainable) data rates are quoted for each path to enable us to make valid comparisons.

6.1.1 Native Data Rates

The IBM 3490E subsystem control units support a channel data rate of up to 9MB/s. The model A20 is capable of attaching up to eight ESCON channels, but only two of them can be concurrently active because the model A20 has two control unit functions. That is, each of the two concurrently active host channels shown in the diagram is capable of a maximum data rate of 9MB/s. Each control unit function buffers the data by dynamically allocating a buffer from the 8MB buffer storage available in the model A20 and associating it with the tape drive allocated by the host system software. The model A20 control unit has an 8MB buffer available, which serves up to 16 tape drives. It is during the process of transferring data from the host channel to the buffer that the data can be compressed using the BAC algorithm component of IDRC.

The speed of the IBM 3490E tape drive is 3MB/s. If the data is compressed in the control unit at a ratio of less than approximately 3:1, the attainable

subsystem throughput is constrained by the drive speed. If the compression ratio achieved is greater than 3:1, the attainable throughput is constrained by the channel speed. Nevertheless, for most applications using conventional DASD, the data rate attained is determined not by the tape drive speed but by another system or application component.

6.1.2 Data Compression

The compression achieved using IDRC is made up of two factors:

- Automatic reblocking of the data to a block size of 128KB, which has a more marked effect on small block sizes
- Applying the BAC algorithm to the data, the effectiveness of which depends on the randomness of the data, and whether or not it has already been compressed (for example, by hardware or software data compression in the host).

IDRC uses an adaptive algorithm that is applied as each block of data is read or written and optimizes the effectiveness of the compression. If the data is known to be unsuitable for compression, the user or application can choose to turn off the IDRC compression by using software parameters. However, the automatic reblocking function is always applied, and it cannot be turned off.

An average compression ratio achieved with normal commercial data is quoted as 3:1 when using the IDRC algorithm. Actual results achieved with specific data will vary.

6.1.3 Effective Data Rates

The theoretical figures for data rates are put into perspective by actual measurements of maximum effective data rates achieved.

Such a measurement study was conducted at the SSD Laboratory in Tucson where one IBM 3490E model A10 control unit and two model B40 drive units were used for the measurements. The host was an IBM 3090-200 running MVS/SP 3.1.0E and DFP 3.1. The SSPD measurement driver, using EXCP, did not perform any processing of the data blocks read from or written to tape. Two data patterns were used in this study to provide compaction ratios of approximately 1.5:1 and 3:1. A third set of results for the uncompacted data case was achieved by setting the JCL parameter TRTCH=NOCOMP to turn off the IDRC compression. Table 8 on page 134, taken from *WSC Flash 9108 IBM 3490E Tape Subsystem Performance*, which documents the study, relates to a subsystem such as the subsystem shown in the diagram, using an ESCON channel, an 8MB buffer, and with *five* drives active.

Note: Because of the five concurrently active drives, the numbers are not the maximum; the objective in showing these numbers is to demonstrate the effect of differing block sizes while keeping the other factors constant. There are performance differences depending on the number of active drives sharing a path. These differences are most noticeable going from one to three drives; when moving from three to eight active drives per path, the performance numbers change less (approximately 0.1MB/s). However, the number of active drives is important, and with IBM 3490E subsystems, control unit constraints can be induced by having too many active drives.

<i>Table 8. Effective Data Rates per Path to an IBM 3490E Tape Drive</i>			
Compaction Ratio	16KB Blocks (MB/s)	32KB Blocks (MB/s)	64KB Blocks (MB/s)
No compaction	2.4	2.7	2.8
1.5:1	2.9	3.8	3.9
3:1	3.2	4.6	6.1

Table 8 is shown as a simple graph in Figure 60 on page 135.

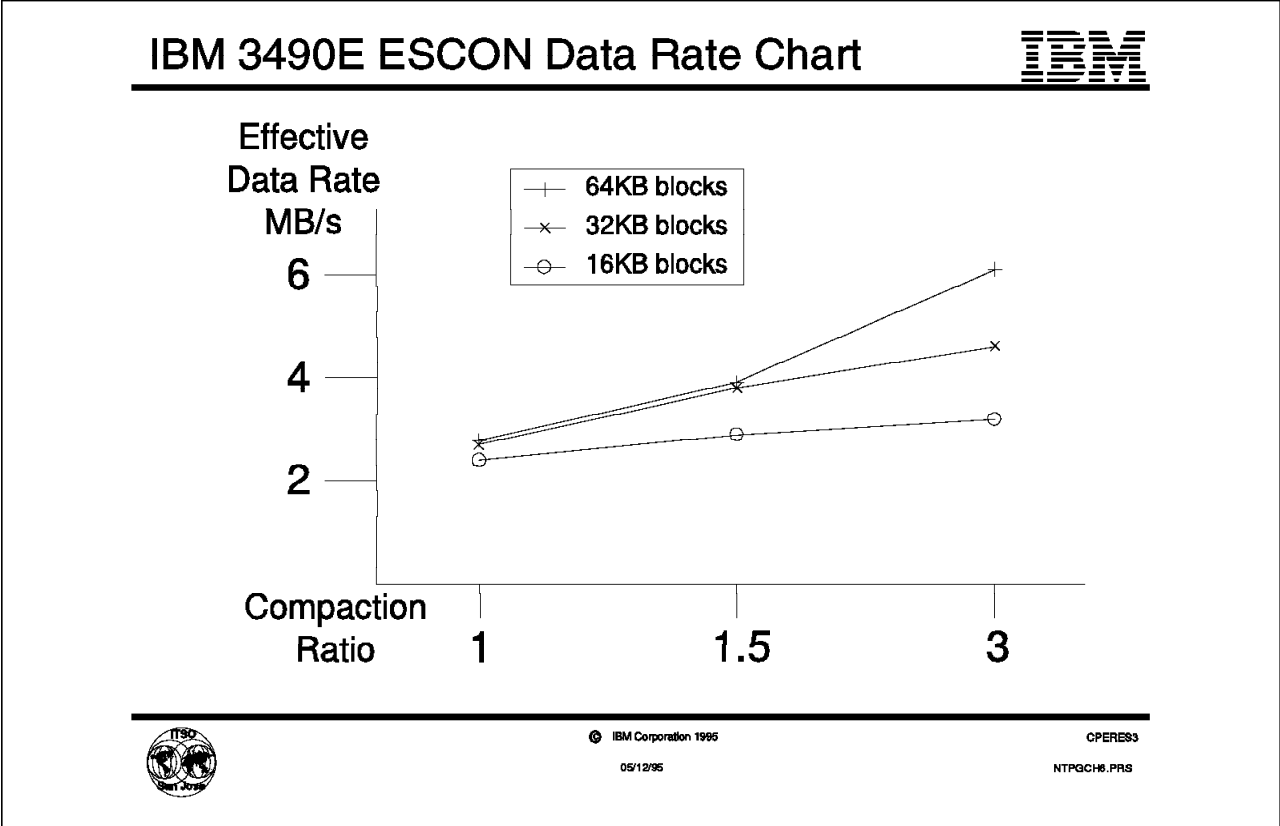

Figure 60. IBM 3490E ESCON Data Rate Chart

6.2 IBM 3490E ESCON Data Rate Chart

The measured data rates illustrate two points about effective data rates as opposed to native data rates in tape subsystems:

- When the data is not compressed, the effective data rate is limited by the drive speed, that is, approximately 3MB/s. However, when the data is compressed, the maximum data rate is approximately 6MB/s.
- The data rate is dependent on block size. With a block size of 16KB and a compression ratio of 3:1, the maximum data rate is 3.2MB/s.

The explanation for this is that not all of the data passed down a channel is user data. Although the channel may send data to the control unit at 9MB/s, a proportion of this is “hand-shaking” exchanges between host and control, sent before and after each block. The effective data rate in a subsystem that is not constrained by the drive speed (or other parts of the overall system), will be the number of megabytes per second of user data sent down the channel. Because the same amount of hand-shaking occurs for each block, regardless of the amount of data in the block, when block sizes are small, the proportion of user data sent down the channel is lower than for larger block sizes.

Note: Do not confuse the two effects of block size. The effect of auto-reblocking is greater when the user block size is small; thus the compression ratio is higher. High compression ratios mean that the effective data rate to the drives will be greater than the drive speed of 3MB/s, and ultimately (with compression ratios of approximately 3:1) the effective data rate can approach the channel data rate. However, the smaller the block size, the

higher the channel overheads, and the lower the effective data rate over the channel.

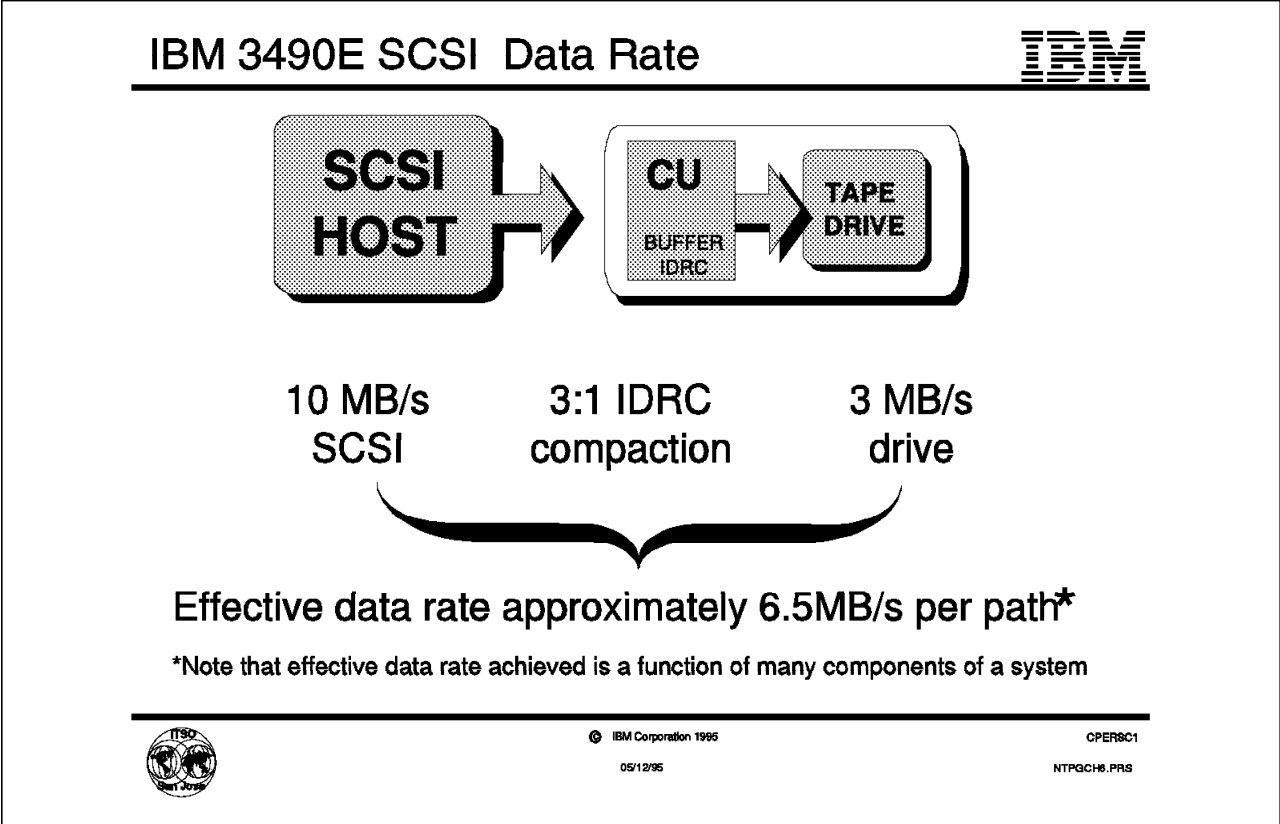

Figure 61. IBM 3490E SCSI Data Rate

6.3 IBM 3490E SCSI Data Rate

Figure 61 shows a SCSI host attached to an IBM 3490E model Cxx control unit and integrated drive unit using a SCSI adapter.

The issues governing performance are exactly the same as in the ESCON example. The channel overheads are slightly different because of the different protocols. Measurement studies with the 3490E model Exx have yielded maximum effective data rates of approximately 6.5MB/s. (Figure 62 shows some of these measurements in a simple graph.)

However, it should be noted that other system factors limit many common tasks to data rates of no more than 2MB/s. Such factors include slow DASD speeds, nonsequential data access patterns, small file transfers, communication overheads, or even overall I/O capabilities of the host.

IBM 3490E SCSI Data Rate Chart

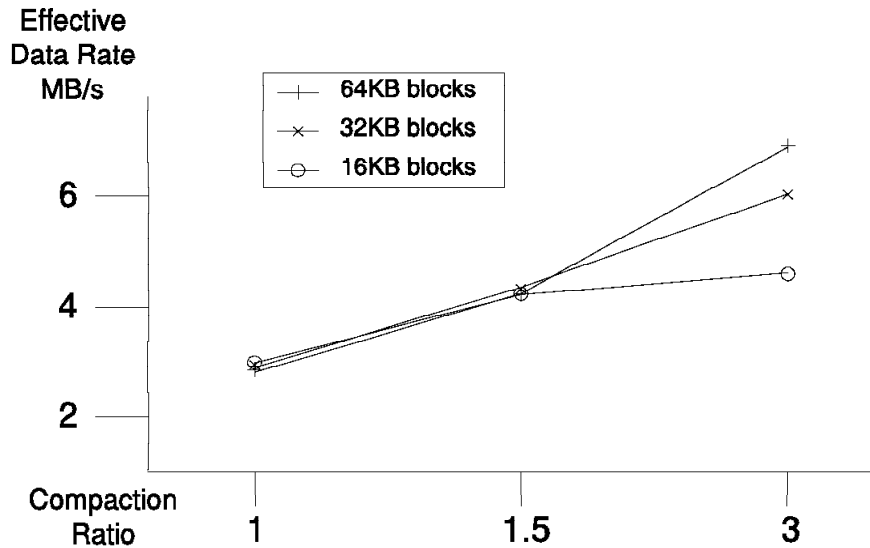

© IBM Corporation 1995
05/12/95

CPE8C9
NTPGCH8.PRS

Figure 62. IBM 3490E SCSI Data Rate Chart

6.4 IBM 3490E SCSI Data Rate Chart

Figure 62 is similar to the graph in Figure 60 on page 135. The measurements were taken in the IBM Tucson Laboratories using an IBM RISC/6000 host writing data to an IBM 3490 E model SCSI-attached tape drive. Table 9 shows the effective data rates used to construct the graph.

Compaction Ratio	16KB Blocks (MB/s)	32KB Blocks (MB/s)	64KB Blocks (MB/s)
No compaction	2.9	2.9	2.9
1.5:1	4.3	4.4	4.3
3:1	4.6	6.0	6.5

The block size effect is not so noticeable in this example going from 16KB to 64KB blocks where the subsystem is limited by the drive speed. When there is no compaction, the data rate is the same for all three block sizes, 2.9MB/s, that is, the limit of the drive speed. With compaction at 1.5:1 the effective drive speed is 1.5 times greater than with no compaction, that is, approximately 4.3MB/s; again the three block sizes show the same data rate to the drive. However, at 3:1 compaction, the block size effect is noticeable, as the data rate to the drive is no longer the limiting factor. The effective data rate down the channel is the limiting factor, and this is block size dependent.

IBM 3590 ESCON Data Rates

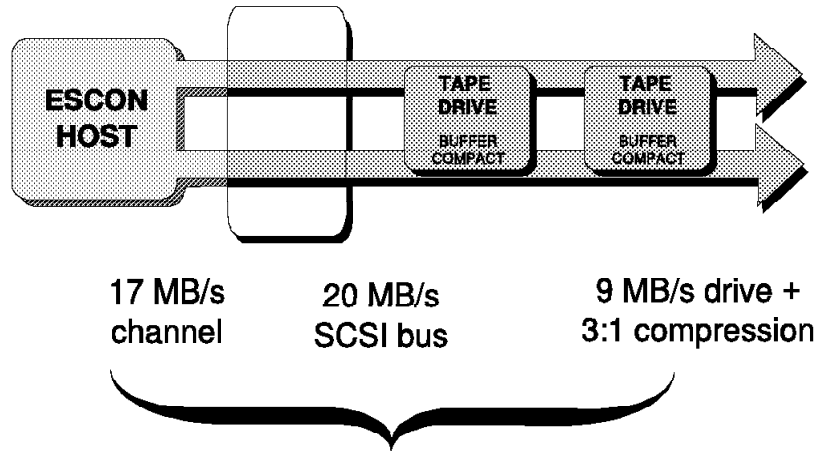

Effective data rate approximately 11MB/s per drive*

*Note that effective data rate achieved is a function of many components of a system - these data rates are based on preliminary engineering data and are subject to change



© IBM Corporation 1995
05/12/95

CPERES2
NTPGCH8.PRS

Figure 63. IBM 3590 ESCON Data Rate

6.5 IBM 3590 ESCON Data Rate

Figure 63 shows an ESCON host attached to an IBM 3590 model A00 control unit using the control unit's two upper-interface ESCON adapters. IBM 3590 tape drives (and integrated control unit functions) are attached to the IBM 3590 model A00 using the control unit's two lower-interface SCSI adapters. The two ESCON paths can be concurrently active, as each drive is attached to both paths and each drive has its own control unit function. (Needless to say, both paths cannot concurrently access the same drive.)

The improved compression algorithm together with the high native drive speed of 9MB/s mean that IBM 3590 subsystems are unlikely to be constrained to the native drive speed (9MB/s). Although final product performance data will not be available until general availability of the product, preliminary laboratory measurements show that, for a 32KB block size (the supported maximum, for example, for most MVS access methods), effective sustained data rates of 8MB/s or more may be achieved where there are no other application, DASD, or system inhibitors. With block sizes of 64KB (that is, coded at the EXCP level), sustained data rates of more than 11MB/s may be achieved. Nevertheless, common MVS applications, such as DASD dumps or DFSMSHsm backups, are constrained (because of DASD data rates, and application, or other system overheads) to rates often substantially below the capability of the tape drive. Further performance information will be published as it becomes available and nearer to the availability date of the product.

IBM 3590 SCSI Data Rates

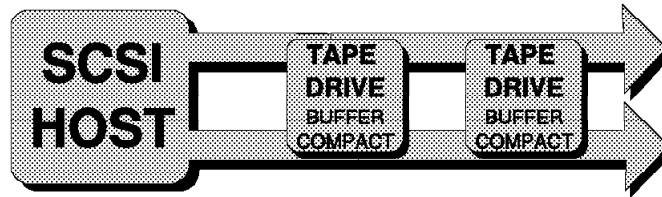

20 MB/s
SCSI

9 MB/s drive +
3:1 compression

Effective data rate approximately 12MB/s*

*Note that effective data rate achieved is a function of many components of a system



© IBM Corporation 1995
05/12/95

CPER8C2
NTPGCH8.PRS

Figure 64. IBM 3590 SCSI Data Rate

6.6 IBM 3590 SCSI Data Rate

Figure 64 is much the same as Figure 63 on page 139. The SCSI host can attach directly to the IBM 3590 tape drives, using the 20MB/s SCSI bus. Each tape drive has two SCSI adapters, which cannot be concurrently accessed.

Maximum effective sustained data rates are expected to be up to 12MB/s, from the preliminary measurements made at the IBM Tucson laboratories. Some of the results are shown as a simple graph in Figure 65 on page 141.

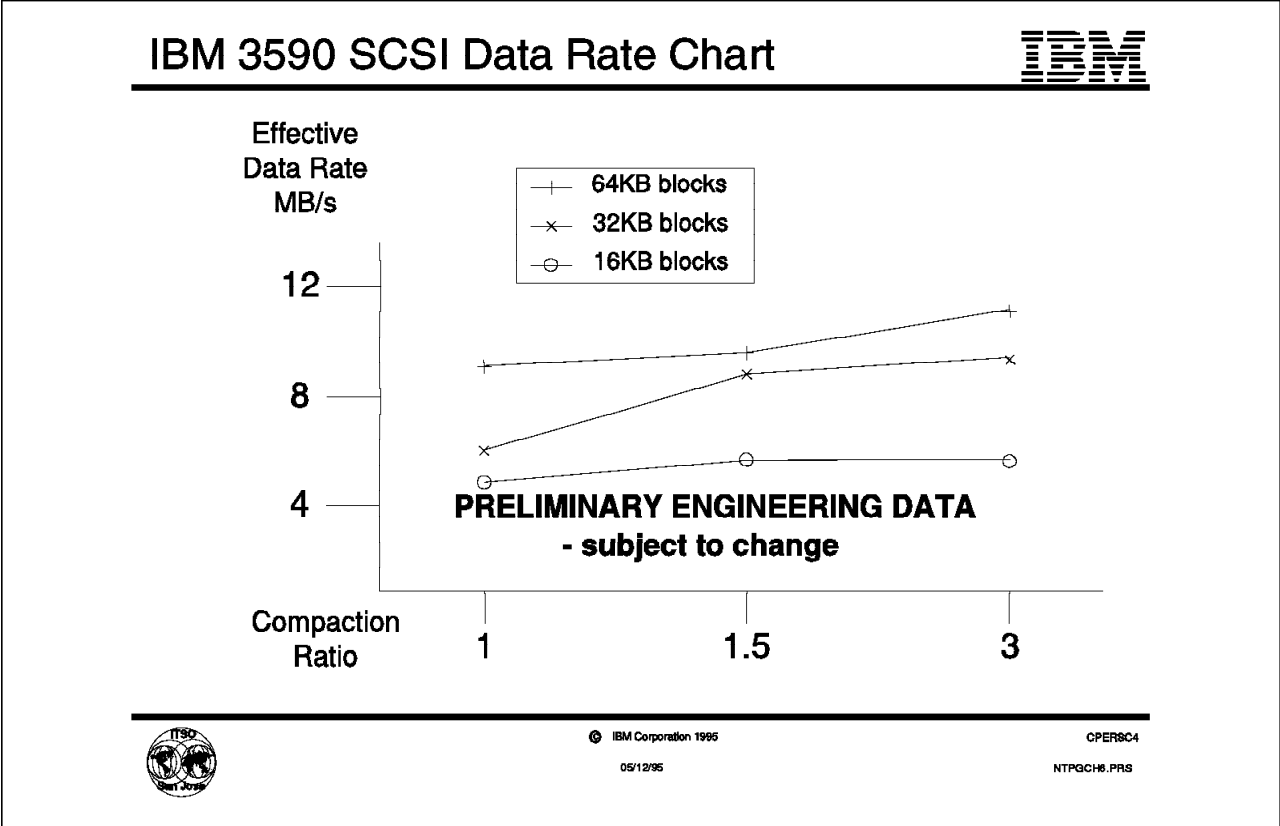

Figure 65. IBM 3590 SCSI Data Rate Chart

6.7 IBM 3590 SCSI Data Rate Chart

Figure 65 shows some of the preliminary data rate measurements made in the IBM Tucson Laboratories, using the IBM 3590 tape drive. For clarity, the results are shown in exactly the same simple graphical form as in Figure 60 on page 135 and Figure 62 on page 138.

Table 10 shows the effective data rates used to construct the graph in Figure 65.

Table 10. Effective Data Rates per Path to an IBM 3590 Tape Drive

Compaction Ratio	16KB Blocks (MB/s)	32KB Blocks (MB/s)	64KB Blocks (MB/s)
No compaction	4.9	6.6	9.0
1.5:1	5.7	8.8	9.4
3:1	5.8	9.2	11.1

IBM AS/400 Data Rate Chart

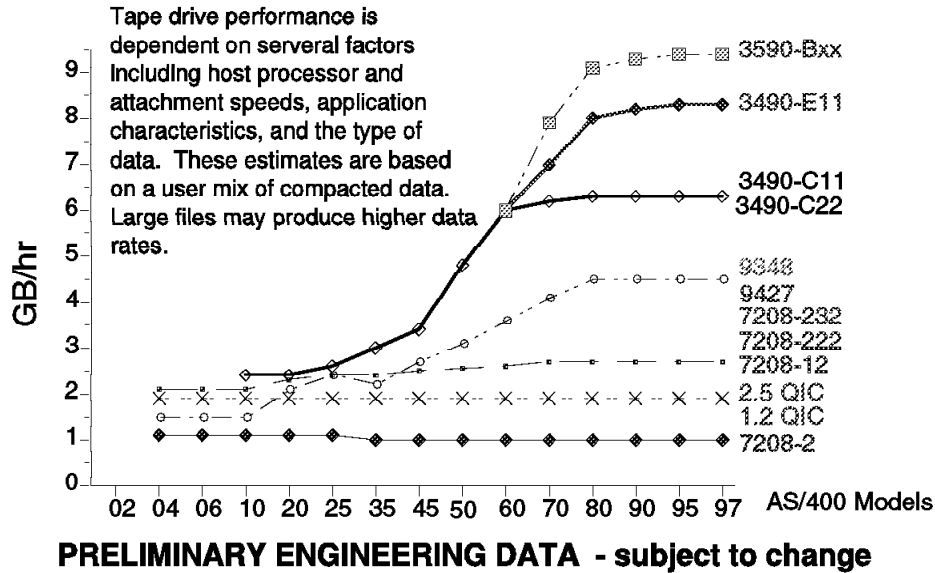

© IBM Corporation 1995
05/12/95

COPERAS1
NTPGCH8.PRS

Figure 66. IBM AS/400 Data Rate Chart

6.8 IBM AS/400 Data Rate Chart

Figure 66 shows the data rate achieved using various AS/400 hosts writing data to various tape drives. (Note that the data rate units for this chart are GB/hr, rather than MB/s.) The graph illustrates two points:

First, it shows the performance improvements expected using the IBM 3590 with an AS/400 host. It shows that, for example, an AS/400 model F80 may save data with an IBM 3590 tape drive up to 20% faster than an IBM 3490 on large files.

Note: It is worth considering here that, for the AS/400 environment, these implied performance enhancements are derived from data rate increases alone; further overall improvements may be seen through cartridge capacity changes and the resulting need for fewer tape mounts. Please refer to AS/400 performance documentation for more detailed information on specific environments.

Second, the graph illustrates the general point that the path to the tape drive is by no means the only consideration in estimating overall performance, or performance improvements with IBM 3590 tape drive. This applies to all of the configurations and platforms discussed in this chapter.

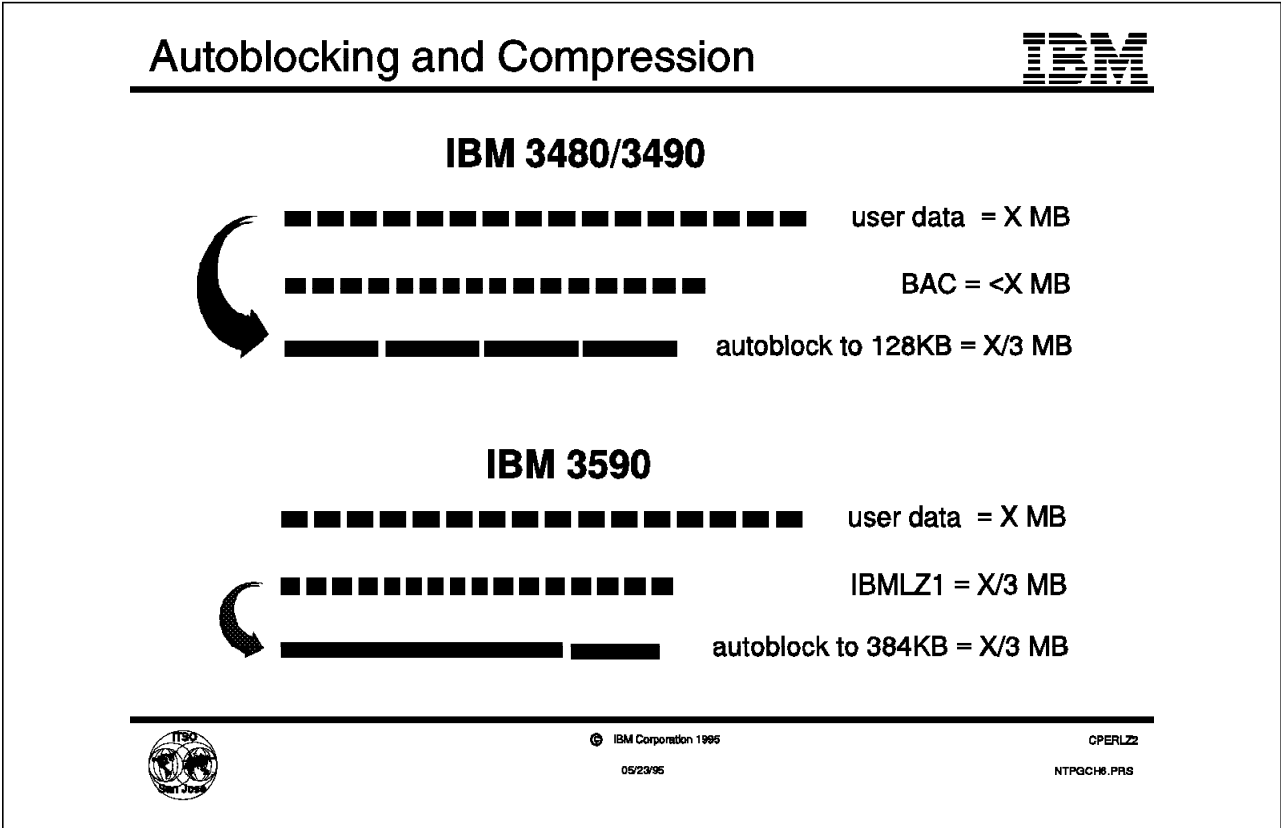

Figure 67. Autoblocking and Compression

6.9 Autoblocking and Compression

As described previously, the compression factor achieved in the tape subsystem is important in two different ways:

- High compression ratios mean that the data occupies less space on the cartridge, fewer cartridges are used, and less space is required to store the cartridges.
- High compression ratios mean that the effective data rate to the tape drive is increased, and thus the tape drive is less likely to be the limiting factor in the performance of the subsystem.

The IBMLZ1 algorithm is considered to be generally more effective than IDRC, and yet the average compression ratio quoted is approximately 3:1, the same ratio used for IDRC. The differences between the implementation of IDRC and the IBMLZ1 algorithm are discussed below.

6.9.1 Cartridge Capacity

The space savings achieved using the IBM 3590 are calculated slightly differently from those achieved using IDRC.

IDRC overall compaction (in the example in Figure 67, 3:1) was achieved in two parts, that is, reblocking and application of BAC. A cartridge capacity of 800MB means that 800MB of user data can be written to the tape if no reblocking or compression is applied. In IBM 3490E drives, reblocking (to 128KB blocks) is automatic, so some space savings are achieved even if the compression is

turned off by the software. Thus the average 3:1 compression is calculated as a combination of the two factors.

The IBM 3590 drives also reblock automatically (to 384KB blocks). However, the IBM 3590 High Performance Tape Cartridge capacity of 10GB means that 10GB of user data, when reblocked to 384KB, will fill the tape. Thus the average 3:1 compression in this case is entirely due to the IBMLZ1 compression algorithm.

6.9.2 Compression Improvements

The IBMLZ1 algorithms are in principle and overall more effective than BAC (although not always). The effectiveness of both algorithm varies as a function of the specific data to which it is applied. From measurements conducted by IBM Tucson on a limited but broadly based sample of MVS customer data, and from IBM MVS channel traces conducted by IBM San Jose, in general IBMLZ1 gave more than 60% higher compression ratios than BAC. IBMLZ1 is more adaptive and should thus be applicable to a wider range of data types than IDRC, meaning better compression should be achieved on average. However, the variation in the compression factors for different data types is likely to be wider. For example, data which achieves very high compression factors with IDRC may not change a great deal using the new algorithm, whereas other data where IDRC was not effective may become a better candidate for compression.

6.9.3 Moving to the New Cartridges

After taking the above into consideration, it is possible to calculate the tape capacity required. However, it is also important to understand which applications can use the 10GB tape capacity (DFSMSHsm, for example) and which cannot (full volume dumps for example). See Section 1.11, "IBM 3590 Tape Space Utilization" on page 20.

6.10 Final Note

Although the IBM 3590 tape drive is capable of a 9–20 MB/s instantaneous data rate, other components of the system may limit the actual effective data rate. For example, in a RISC/6000 environment, without file system striping, the disk file system and utilities will typically limit the data rates to under 4MB/s. For memory-to-tape applications, a RISC/6000 can achieve data rates of up to 12MB/s (or 9MB/s if the data is uncompressed); tape-to-tape applications could be nearly as fast. In the S/390 environment, dumps from DASD are limited by the data rate from the disk, and in batch work, job suite dependencies and the typical start and stop nature of the applications may be the limiting factors.

As a final note, the following points should be considered when using the IBM 3590:

- **Large block sizes**

In the S/390 environment, use at least 32KB blocks or 64KB when supported by the application.

In the RISC/6000 environment, set the block size in SMIT or use *chdev*. In variable blocked mode be sure the utility has the proper blocking characteristic set. The performance of intermediate block sizes (from 32KB to 128KB) may be improved by setting Bus Domination ON in SMIT or *chdev*.

- **Fast DASD data rate**

In the S/390 environment, performance is often limited by the data rate from the DASD or the application. DFSMS data set striping can help some applications. However tape-to-tape applications generally will be the fastest.

In the RISC/6000 environment, use sequential DASD access whenever possible, allocating large files using center tracks, and defragmenting periodically. Use striped file systems and fast DASD; simulate striping with AIX 3.2.5 allocation maps.

- **Optimum compression resources**

If you are using LZ2-based host compression in the S/390 environment (hardware or software), then you should disable the IBMLZ1 tape compression.

Usually, hardware compression should be favored over host software compression, for optimum resource utilization and performance. In the RISC/6000 environment, the IBMLZ1 tape data compression is faster than host utility compression.

- **Host connections**

For SCSI hosts, use the fast and wide SCSI adapter. Avoid sharing the host connection with other nontape devices.

Chapter 7. The IBM Magstar Virtual Tape Server

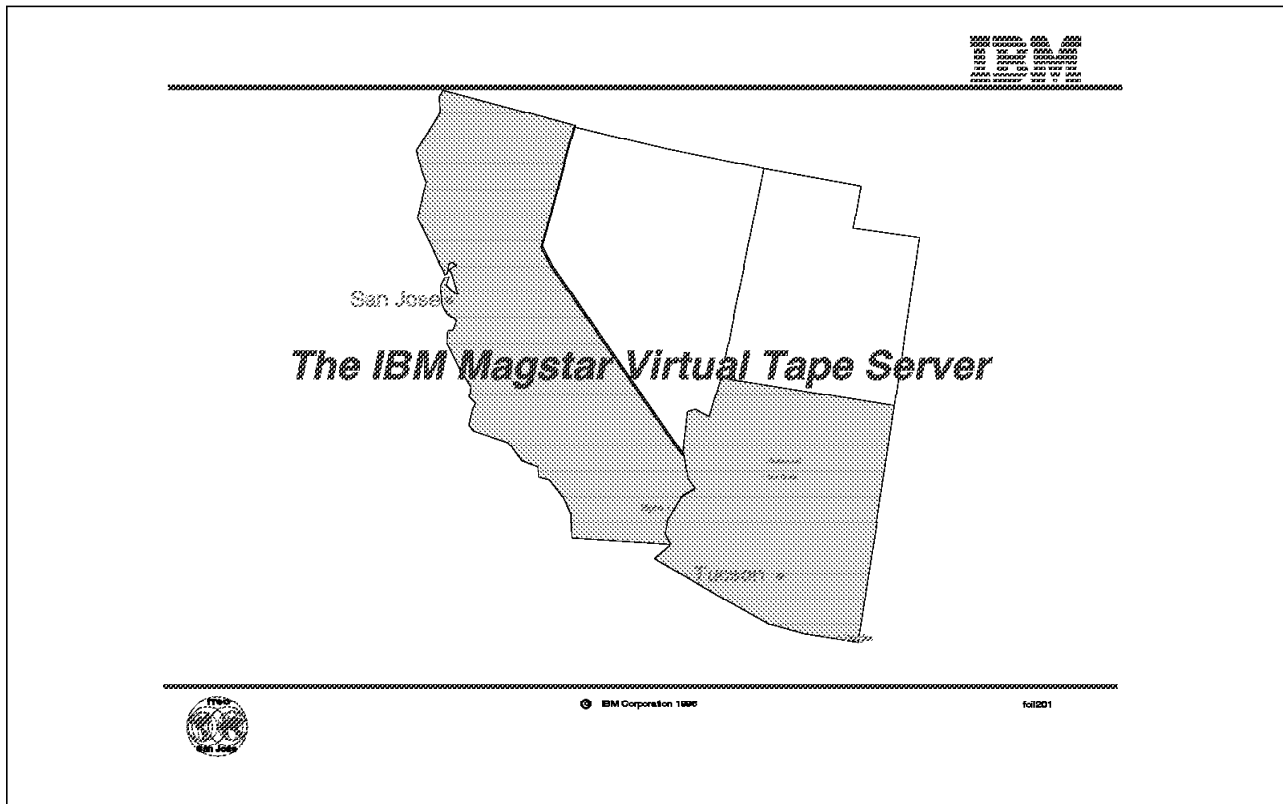

Figure 68. Title Slide of the IBM Magstar Virtual Tape Server Presentation

The IBM Magstar Virtual Tape Server (VTS), integrated with the IBM Tape Library Dataservers, delivers an increased level of storage capable to the traditional storage products hierarchy. The host software sees Virtual Tape Server subsystem as a 3490 Enhanced Capability (3490E) Tape Subsystem with associated standard (CST) or Enhanced Capacity Cartridge System Tapes (ECCST). This virtualization of both the tape devices and the storage media to the host allows for transparent utilization of the capabilities of the IBM 3590 tape technology.

In this chapter, we present the IBM Magstar Virtual Tape Server (VTS) and cover the following topics:

- We introduce and give you a brief overview of the key attributes and the general concept of the Virtual Tape Server subsystem.
- We describe the hardware components and building blocks and list the supporting host software products.
- We provide the information required for sizing and configuration of a Virtual Tape Server subsystem.
- We explain the implementation considerations for supported host software environments.
- We describe migration and operational considerations.

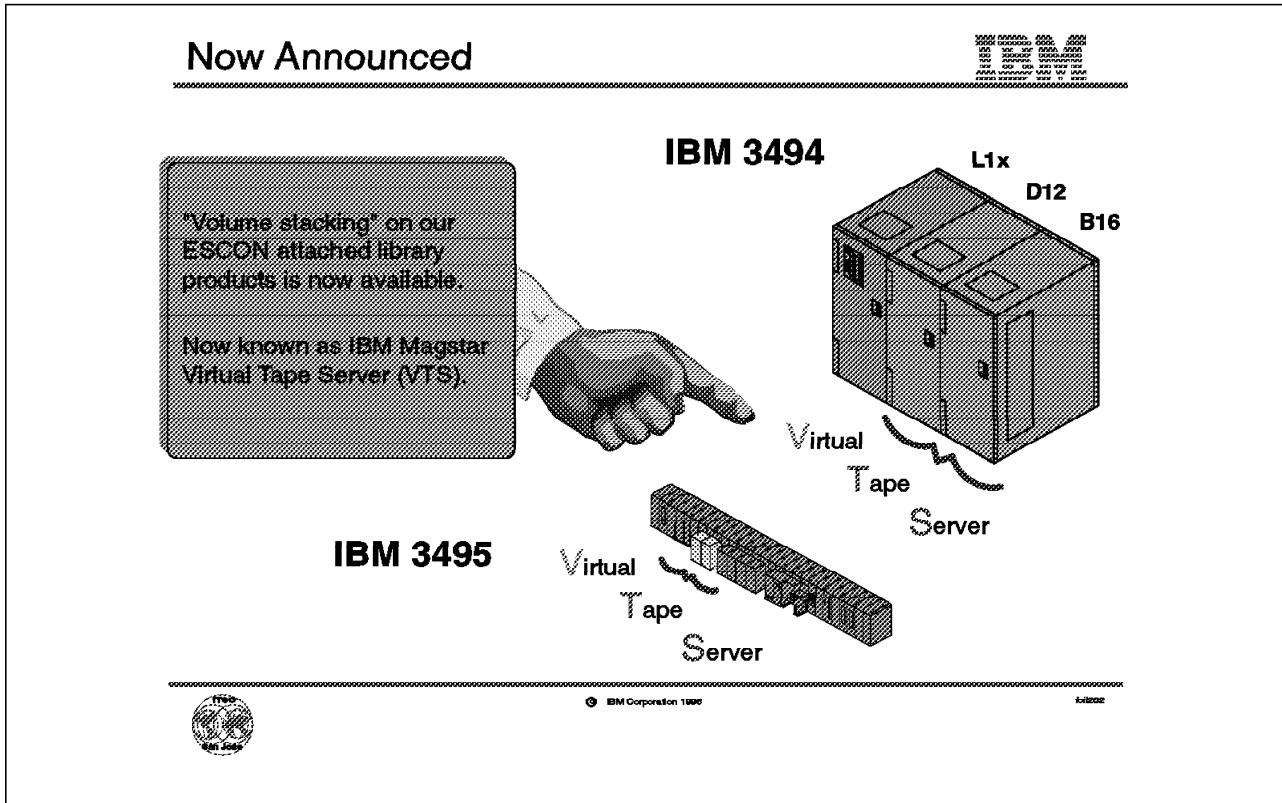

Figure 69. Now Announced the IBM Magstar Virtual Tape Server

7.1 Now Announced the IBM Magstar Virtual Tape Server

In April 1995, together with the announcement of the IBM Magstar 3590 High Performance Tape Subsystem, IBM announced a statement of direction to deliver capacity-enabling technology (also called volume stacking) on our ESCON-attached library products.

Fulfilling this statement of direction, IBM now announces the IBM Magstar Virtual Tape Server (VTS) for IBM 3494 and 3495 Tape Libraries.

7.1.1 Virtual Tape Server for IBM 3494 Tape Library

The VTS subsystem in an IBM 3494 is installed in two frames:

- One IBM 3494-D12 drive unit frame houses the IBM 3590-B1A tape drives that are dedicated to the Virtual Tape Server function.
- One IBM 3494-B16 Virtual Tape Server unit frame which contains the required hardware and microcode to enable full 3590 Magstar tape storage capacity, plus cartridge storage cells.

Figure 69 shows the minimum configuration of a Virtual Tape Server subsystem in IBM 3494 Tape Library including one library unit frame, one drive unit frame, and one Virtual Tape Server unit frame.

7.1.2 Virtual Tape Server for IBM 3495 Tape Library

Installed in an IBM 3495 Tape Library, the Virtual Tape Server subsystem is composed of:

- One IBM 3590-A14 frame that houses four IBM 3590-B1A tape drives which are dedicated to the Virtual Tape Server function. No IBM 3590-A00 ESCON tape controller is required.
- One IBM 3495-B16 Virtual Tape Server unit frame that contains the required hardware and microcode to enable full tape storage capacity.

Figure 69 on page 148 shows the smallest Virtual Tape Server subsystem in an IBM 3495 Tape Library configuration consisting of an IBM 3495 Tape Library Model L20, including the IBM Magstar Virtual Tape Server (VTS).

Introduction to the IBM Magstar VTS

- **Transparent capacity exploitation and management**

- **Host software transparency**
- **IBM Magstar Virtual Tape Server Controller**
 - Automatically fills and manages Magstar 3590 cartridge capacity
 - Volume movement to and from the Tape Volume Cache and 3590 cartridges or Magstar tape drives
- **High Capacity Tape Volume Cache**
 - All host interaction goes through the cache
 - Multi-logical volume access
 - Virtual volumes reaccessible at disk speeds

- **Fully integrated in IBM 3494/3495 Tape Libraries**

- **ESCON channel attachment**
- **Coexistence in same library with 3490 / 3490E / 3590**
- **Automatic exploitation of future tape technology evolution**

Integration of proven IBM technologies :
Magstar 3590, Serial Storage Architecture, Storage Management Techniques

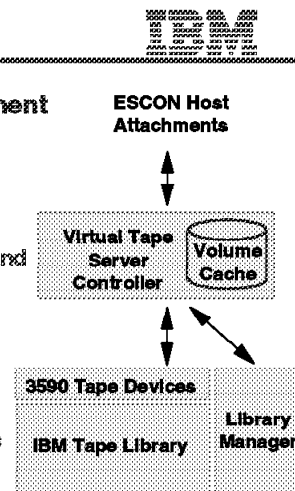

© IBM Corporation 1996

51220

Figure 70. Introduction to the IBM Magstar Virtual Tape Server

7.2 Introduction to the IBM Magstar Virtual Tape Server

The IBM Magstar Virtual Tape Server Controller, Tape Volume Cache, and the IBM 3590 Magstar tape drives, together with the required housing, make up the IBM Magstar Virtual Tape Server (VTS) subsystem, allowing automatic utilization of the Magstar cartridge storage capacity and the drive data rate of 9 MB/s.

7.2.1 Transparent Capacity Exploitation and Management

The IBM Magstar Virtual Tape Server (VTS) automatically fills the 30 GB Magstar 3590 cartridge. This is completed by the built-in storage management functions and is transparent to any software, whether operating system or third-party program.

7.2.1.1 Host Software Transparency

The operating system knows only about tape drives and volumes and does not need to manage the storage of virtual and stacked volumes. Therefore, in most installations you do not need to change your operating system software at all.

7.2.1.2 IBM Magstar Virtual Tape Server Controller

The IBM Magstar Tape Server Controller and its associated microcode, are the key components of the Virtual Tape Server subsystem:

- It automatically fills and manages Magstar 3590 cartridge capacity.
- It controls and manages the volume movement to and from the tape volume cache and 3590 cartridges or Magstar tape drives.

7.2.1.3 High Capacity Tape Volume Cache

The tape volume cache (TVC) is the disk component of the Virtual Tape Server subsystem. It is used to buffer virtual volumes created by the host before they are written to the physical IBM 3590 tape devices. It has these advantages:

- All host interaction is through the tape volume cache. The operating system sees 32 virtual tape devices which are physically represented by storage space on the tape volume cache's RAID (Redundant Array of Independent Disk) DASD. The operating system cannot directly write a logical volume to a stacked Magstar cartridge.
- Multiple virtual volumes can be accessed in parallel because they physically reside on the DASD.
- Virtual volumes are reaccessible at disk speeds. Tape motion commands such as space, locate, rewind, and unload are mapped into disk commands and happen in milliseconds, not seconds as for traditional tape commands.

7.2.2 Fully Integrated in IBM 3494 and IBM 3495 Tape Libraries

The IBM Magstar Virtual Tape Server (VTS) can only be installed inside an IBM 3494 or 3495 Tape Library, and is fully supported through the Library Manager. For instance, the location of virtual volumes and physical Magstar cartridges is stored in the Library Manager console. Logical and physical volume serial ranges are defined at the Library Manager console.

7.2.2.1 ESCON Channel Attachment

The IBM Magstar Virtual Tape Server (VTS) is attached to the host through ESCON channels, allowing two simultaneous ESCON data transfers.

7.2.2.2 Coexistence in Same Library with IBM 3490, 3490E or 3590

The IBM Magstar Virtual Tape Server (VTS) can be installed in an IBM 3495 with IBM 3490, 3490E, and 3590 tape drives. Inside an IBM 3494, the IBM Magstar Virtual Tape Server (VTS) can be installed together with IBM 3490E, and ESCON- and SCSI-attached IBM 3590 tape drives. This ensures investment protection and ease of migration.

7.2.2.3 Automatic Exploitation for Future Tape Technology Evolutions

The concept of the IBM Magstar Virtual Tape Server (VTS) allows for immediate utilization of future enhancements to the IBM 3590 tape technology without impact to the host software.

7.2.3 Integration of Proven IBM Technologies

The IBM Magstar Virtual Tape Server (VTS) is built using proven IBM technologies. The Virtual Tape Server controller, for example, is based on RISC technology

7.2.3.1 Magstar 3590

These are the industry's leading half-inch tape drives for performance, capacity, and reliability. Over 7,000 IBM 3590 tape drives have been shipped since general availability in September 1995.

7.2.3.2 Serial Storage Architecture

Serial Storage Architecture (SSA), together with high-performance disks, provides improved performance and availability over previous-generation disk architecture.

7.2.3.3 Storage Management Techniques

The storage management techniques are built on over 20 years of IBM experience; they use for example, many features and functions found in IBM's industry-leading DFSMSHsm and AD SM software products.

Virtual Tape Server Key Attributes

- **One VTS subsystem per IBM 3494 or 3495**
 - ◆ **32 logical 3490E drives**
 - ◆ **Up to 50,000 logical Volumes**
 - MEDIA1 = 400 MB
 - MEDIA2 = 800 MB
- **Defined physical configurations**
 - ◆ **IBM 3494**
 - Three IBM 3590-B1As plus 36 GB TVC
 - Six IBM 3590-B1As plus 72 GB TVC
 - ◆ **IBM 3495**
 - Four IBM 3590-B1As plus 36 GB TVC
 - Four IBM 3590-B1As plus 72 GB TVC
- **Up to 40 TB of tape data per VTS subsystem**

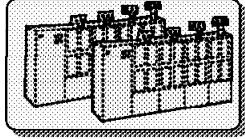
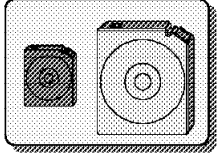
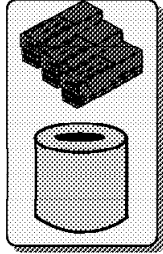

© IBM Corporation 1998

Figure 71. Virtual Tape Server Key Attributes

7.3 Virtual Tape Server Key Attributes

Figure 71 lists the logical and physical key attributes of the IBM Magstar Virtual Tape Server (VTS).

7.3.1 One VTS Subsystem per IBM 3494 or IBM 3495

Currently, one Virtual Tape Server subsystem can be installed in a single IBM 3494 or 3495 tape library. The Virtual Tape Server subsystem can be integrated into an existing automated tape library in addition to, or instead of, already installed physical tape drives. VTS tape drives can be shared across different platforms and Sysplexes, just like any other IBM 3490E subsystem can in our libraries. For details of the installation requirements, please refer to Figure 76 on page 167 through Figure 82 on page 179.

7.3.1.1 Number of Logical 3490E Tape Drives

Before this announcement, no more than sixteen IBM 3490E tape drives could be installed in a single IBM 3494 tape library or an IBM 3495-L20.

Each Virtual Tape Server subsystem presents itself to the host as 32 3490E tape drives, thus allowing much more parallelism in tape processing. Because of the large number of logical tape drives, more drives can now be dedicated to different hosts and platforms. In most cross-platform installations, dynamic and automatic sharing of tape drives may no longer be required, although the Virtual Tape Server fully supports existing tape drive sharing methods.

7.3.1.2 Up to 50,000 Logical Volumes

A single Virtual Tape Server subsystem can manage up to 50,000 logical 3490E volumes, making even a small tape library look very large. We describe logical volumes in detail in Section 7.4, “Virtual Tape Server Key Concepts” on page 156.

Logical volumes are defined through the Library Manager console and can have two different sizes:

- MEDIA1=400 MB
MEDIA1 reflects a CST type of cartridge written in 36-track recording technology without using the Improved Data Recording Capability (IDRC) that a physical IBM 3490E tape drive provides.
- MEDIA2=800 MB
MEDIA2 reflects an ECCST type of cartridge written in 36-track recording technology without using the IBM 3490E’s IDRC.

Logical 3490E volumes are stacked on physical Magstar cartridges allowing effective use of their large capacity of +30 GB and of the IBM 3590 tape drive’s excellent performance.

The number of stacked Magstar 3590 physical cartridges managed by the IBM Magstar Virtual Tape Server (VTS) is limited only by the number of storage slots inside your IBM 3494 or 3495 tape library.

7.3.2 Defined Physical Configurations

Regardless of the physical Virtual Tape Server configuration, the logical attributes such as the number of virtual drives and volumes remain the same as listed above.

7.3.2.1 IBM 3494

The Virtual Tape Server in an IBM 3494 is supported in two configurations at general available time according to the number of physical IBM 3590-B1A tape drives and tape volume cache storage capacity:

- Three IBM 3590-B1As plus 36 GB of tape volume cache
If your tape operation is inhibited by the number of tape drives available but not in terms of throughput, you might consider installing this configuration. For details on sizing the IBM Magstar Virtual Tape Server (VTS), please refer to Figure 88 on page 191.
- Six IBM 3590-B1As plus 72 GB of tape volume cache
This configuration is the maximum configuration for a Virtual Tape Server subsystem in an IBM 3494.

More configurations are being tested; support for these will be announced at the completion of testing. Some of the configurations being tested are four- and five-drive configurations.

7.3.2.2 IBM 3495

An IBM 3590-A14 frame included in a IBM 3495 tape library must always contain four IBM 3590-B1A tape drives. Because the IBM 3590-B1As used by the Virtual Tape Server are installed in an IBM 3590-A14 frame, the following two configurations are available:

- Four IBM 3590-B1As plus 36 GB of tape volume cache
- Four IBM 3590-B1As plus 72 GB of tape volume cache

7.3.3 Up to 40 TB of Tape Data per Virtual Tape Server Subsystem

The IBM Magstar Virtual Tape Server (VTS) introduces new dimensions for managing tape data. Instead of wasting tape storage capacity by not effectively utilizing the full length of a tape cartridge, the IBM Magstar Virtual Tape Server (VTS) occupies only the amount of tape storage necessary to store the number of bytes written by a host application. For instance, a tape data set of 200 MB which is written to a virtual 3490E MEDIA2 cartridge will occupy only 200 MB on the tape volume cache and on the stacked Magstar cartridge and not use the possible 800 MB.

Defining the maximum number of logical volumes using MEDIA2 only, and making full use of their 800 MB capacity, allows you to store up to 40 TB of tape data in a single Virtual Tape Server subsystem.

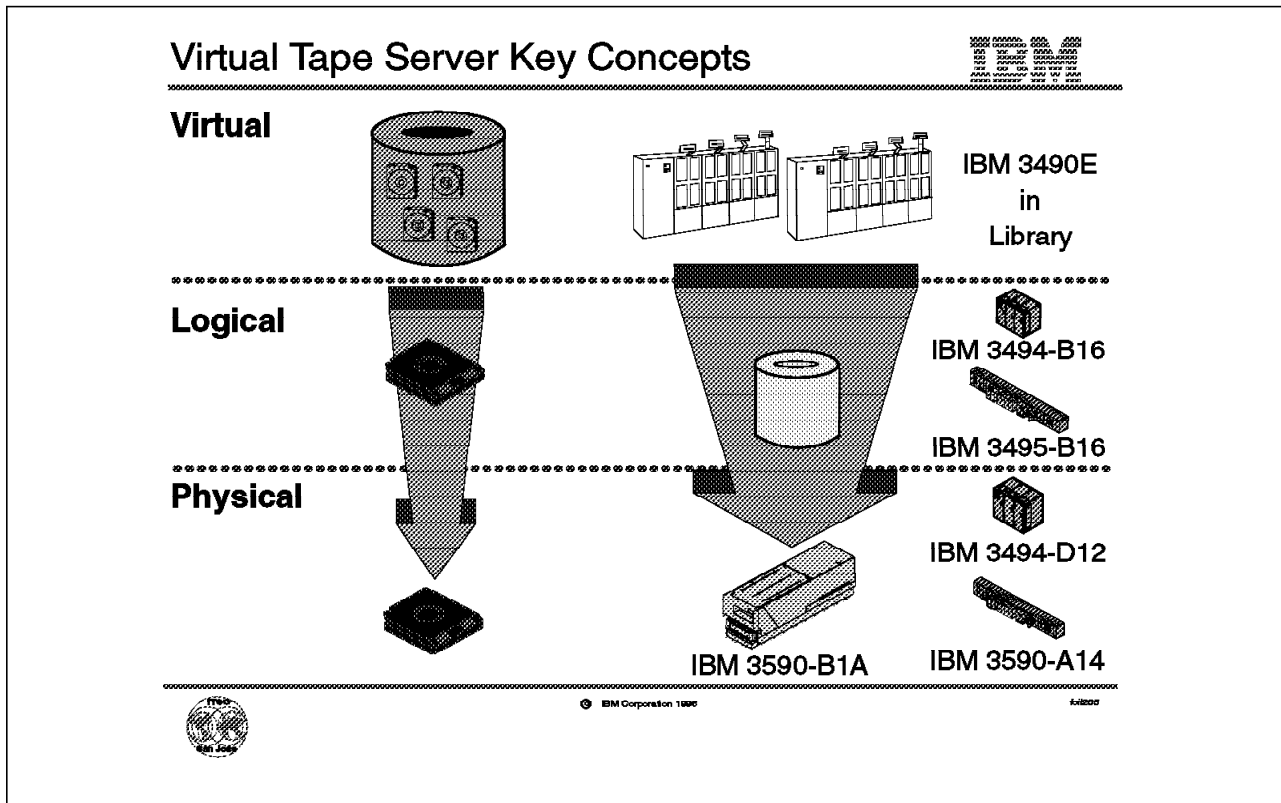

Figure 72. Virtual Tape Server Key Concepts.

7.4 Virtual Tape Server Key Concepts

Along with introducing the IBM Magstar Virtual Tape Server (VTS), we introduce new views of volumes and devices because of the different knowledge about volumes and devices in the host system and the hardware. Using a Virtual Tape Server subsystem, the host application writes tape data to virtual devices. The volumes created by the hosts are called Virtual Volumes and are physically stored in a tape volume cache which is built from RAID DASD.

Through tape volume cache management policies, the virtual tape server management software moves host-created volumes from the tape volume cache to a Magstar cartridge managed by the Virtual Tape Server subsystem. Once a virtual volume is moved from the tape volume cache to tape, it becomes a logical volume.

To allow software transparency and implementation of a Virtual Tape Server subsystem with no changes to the host's operating system software, the host has only a virtual view of the volumes and tape drives managed by the Virtual Tape Server subsystem. The host cannot distinguish physical from virtual volumes or their respective tape drives and will treat them as if they were "real" cartridges and devices.

Management of physical Magstar tape drives and Magstar cartridges is completely under control of the VTS storage management software.

7.4.1 Virtual Volumes

When the host application writes tape data to the IBM Magstar Virtual Tape Server (VTS), a virtual volume is created. Virtual volumes are physically stored in the tape volume cache and all host commands are issued to the virtual volume residing on DASD. All host interaction with tape data in a Virtual Tape Server subsystem is through virtual volumes and through virtual tape devices.

Each virtual volume has the following characteristics (just like a real volume):

- It has a unique volume serial (volser) number known to the host.
- It is loaded and unloaded on a virtual device.
- It supports all tape write modes, including Tape Write Immediate.
- It contains all standard tape marks and data blocks.
- It supports an IBM standard label.
- It can be appended to after it was initially written from the beginning of tape.
- Data written is guaranteed to be in the tape volume cache when a command is completed successfully that either implicitly or explicitly causes synchronization.
- Each host written record has a logical block ID.
- End of volume is signaled when the total number of bytes written has reached 400 MB for an emulated CST or 800 MB for an emulated ECCS T volume.

Virtual volumes can exist only in an IBM 3494 or 3495 tape library. You can direct a tape data set to a virtual tape drive by directing it into a specific tape library.

7.4.2 Virtual Devices

From a host perspective, the Virtual Tape Server subsystem looks like two IBM 3490E tape control units, each with 16 devices attached through ESCON channels. Virtual tape drives are defined just like physical IBM 3490-A10 controller with 16 addresses through HCD (Hardware Configuration Definition), or through IOCP (I/O Configuration Program), and MVSCP or HCPRIO macro. However, you should not define a preferred path for the virtual devices.

An IOCP example of two VTS strings has been included showing the virtual drives configured using the CUADD statements:

Virtual Tape Server IOCP

```
9032 - PORT D6 = CHPID'S 29 & 32
9032 - PORT D7 = CHPID'S 2A & 35
```

```
*
      CNTLUNIT  CUNUMBR=32E,PATH=(32,29),UNIT=TAPE,           X
              UNITADD=((00,16)),LINK=(D6,D6),CUADD=0
      CNTLUNIT  CUNUMBR=35E,PATH=(35,2A),UNIT=TAPE,           X
              UNITADD=((00,16)),LINK=(D7,D7),CUADD=0
TAPE1AEO IODEVICE ADDRESS=(1AEO,16),UNIT=TAPE,CUNUMBR=(32E,35E), X
              UNITADD=00
*
      CNTLUNIT  CUNUMBR=32F,PATH=(32,29),UNIT=TAPE,           X
              UNITADD=((00,16)),LINK=(D6,D6),CUADD=1
      CNTLUNIT  CUNUMBR=35F,PATH=(35,2A),UNIT=TAPE,           X
```

```

UNITADD=((00,16)),LINK=(D7,D7),CUADD=1
TAPE1AFO IODEVICE ADDRESS=(1AFO,16),UNIT=TAPE,CUNUMBR=(32F,35F),      X
UNITADD=00

```

Each virtual device has the following characteristics (just like real tape devices):

- It has a host device address.
- It is included in the I/O generation for the system.
- It is varied online or offline to the host.
- It signals ready when a virtual volume is loaded.
- It responds and processes all IBM 3490E I/O commands
- It becomes not ready when a virtual volume is rewound and unloaded.

The functionality of the 3490E Integrated Cartridge Loader (ICL) is also included in the virtual device's capability. All virtual devices indicate that they have an ICL. You can associate a media type with the cartridge loader that will allow fast access for scratch mounts. The active status of the cartridge loader depends on the availability of scratch volumes of the assigned media type.

7.4.3 Logical Volumes

When a virtual volume is moved from the tape volume cache, the process is called Destaging, and the volume becomes a logical volume. When a logical volume is moved from a Magstar cartridge to the tape volume cache, the process is called staging and the volume becomes a virtual volume again.

As virtual volumes are moved from the tape volume cache to a Magstar cartridge, they are stacked on the cartridge end to end, taking up only the number of bytes written by the host, thereby effectively utilizing all of the cartridge's storage capacity.

You define the volume serial numbers for the logical volumes through the Library Manager console. The Library Manager console associates a Fast-Ready attribute with the category that the volume serial numbers are defined within. The Library Manager assigns the logical volumes to the insert category and notifies all attached hosts. Subsequent host inventory processing is performed as for physical CST and ECCST volumes.

Because a logical volume resides on a physical cartridge together with many other logical volumes, the library containing virtual and logical volumes must be treated as a closed store. This means that you can move the data on the volumes electronically but not physically.

Note: Currently, stacked Magstar cartridges cannot be removed from the IBM Magstar Virtual Tape Server (VTS). Therefore, these cartridges cannot be ejected from the tape library.

7.4.4 Physical Volumes

The physical Magstar cartridges used by the IBM Magstar Virtual Tape Server (VTS) to store logical volumes are totally under the control of the Virtual Tape Server subsystem and are not known to the hosts. The physical volume is also called "stacked volume." However, they must have unique volume serial numbers like any other cartridge in a tape library.

Through the Library Manager console, you define which cartridges are to be used by the Virtual Tape Server subsystem. Logical volumes are mapped by the internal storage management software.

7.4.5 Physical Devices

The physical Magstar tape drives installed in the IBM Magstar Virtual Tape Server (VTS) are invisible to any attached host system. They are completely under the control of the Virtual Tape Server subsystem and therefore cannot be addressed by any host system.

Virtual Tape Server Hardware Overview

• IBM 3494 Tape Library

- One Model L10, L12, or L14 frame
- One VTS subsystem per IBM 3494
 - One IBM 3494-D12 housing three or six IBM 3590-B1A tape drives
 - One IBM 3494-B16 frame including the Tape Volume Cache and the VTS subsystem controller
- Additional D10, D12, D14, S10 frames

• IBM 3495 Tape Library models L20, L30, L40, L50

- One VTS subsystem per IBM 3495
 - One IBM 3590-A14 frame housing four IBM 3590-B1A tape drives
 - One IBM 3495-B16 frame including the Tape Volume Cache and the VTS subsystem controller

IBM 3494

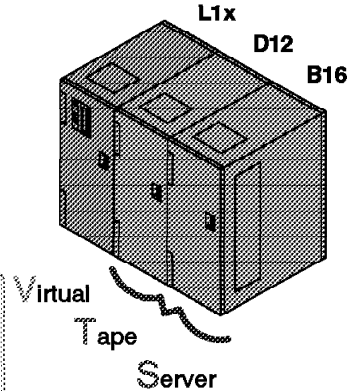

© IBM Corporation 1996

51200

Figure 73. Hardware Overview

7.5 Hardware Overview

This section describes hardware overview for Virtual Tape Server.

7.5.1 IBM 3494 Tape Library

An IBM 3494 Tape Library offers great configuration granularity because it is made up of frames of identical size.

An IBM 3494 Tape Library including the IBM Magstar Virtual Tape Server (VTS) is composed of the hardware frames discussed below.

7.5.1.1 One IBM 3494 Model L10, L12, or L14 Control Unit Frame

An IBM 3494 must include one library control-unit frame which contains the Library Manager, the convenience I/O station (optional), and up to two tape drives:

- IBM 3490E-CxA tape drives with an integrated controller in the IBM 3494-L10
- SCSI-attached IBM 3590-B1A tape drives in the IBM 3494-L12
- ESCON-attached IBM 3590-B1A tape drives and the IBM 3590-A00 controller in the IBM 3494-L14.

The IBM 3494-L12 and IBM 3494-L14 library control unit frame can be installed without drives. For an IBM 3494-L10 frame, you must submit a Request for Price Quotation (RPQ).

7.5.1.2 One VTS Subsystem per IBM 3494

Currently, only one Virtual Tape Server subsystem can be installed in each IBM 3494 tape library. The IBM Magstar Virtual Tape Server (VTS) is made up of the following components:

- One IBM 3494-D12 drive frame housing three or six IBM 3590-B1As

These IBM 3590-B1As are for exclusive use of the IBM Magstar Virtual Tape Server (VTS). They are attached only to the Virtual Tape Server controller, which is installed in the IBM 3494-B16 frame, and are therefore not visible to any attached host. No additional tape drives that directly attach to any host can be installed inside an IBM 3494-D12 frame owned by the Virtual Tape Server.

When ordering an IBM 3494-D12 frame, you must order the tape drives separately, as you would for non-VTS-attached IBM 3494-D12 frames.

The IBM 3494-D12 frame provides 290 cartridge storage cells. The occupancy of the storage cells is under control of the Library Manager. Therefore, these storage cells can be used by the Library Manager to store any physical cartridge, not only those belonging to the Virtual Tape Server subsystem.

- One IBM 3494-B16 frame including the tape volume cache and the VTS subsystem controller

If you open the door of an IBM 3494-B16 frame, you will notice that it looks almost like an IBM 3494-S10 storage unit frame from the inside. This is because the IBM 3494-B16 frame provides storage capacity for 400 cartridges as well as containing the hardware and software components of the Virtual Tape Server. As in the Virtual Tape Server-owned IBM 3494-D12 frame, these storage cells can also contain cartridges that do not belong to the Virtual Tape Server subsystem.

7.5.1.3 Additional IBM 3494 Model D10, D12, D14, or S10 Frames

An IBM 3494 tape library can be composed of up to 16 frames. An additional 13 frames can be added, consisting of drive unit frame IBM 3494-D10/D12/D14 and storage unit frame IBM 3494-S10.

7.5.2 IBM 3495 Tape Library Models L20, L30, L40, L50

The IBM Magstar Virtual Tape Server (VTS) is integrated in an IBM 3495 tape library by attaching two frames to either model, similar to adding two IBM 3590-A14 frames or a combination of one IBM 3490-A20 tape control unit and one IBM 3490-B40 tape drive box.

7.5.2.1 One Virtual Tape Server Subsystem per IBM 3495

At this time, only one Virtual Tape Server subsystem can be added to an IBM 3495 tape library. The Virtual Tape Server consists of:

- One IBM 3590 Model A14 frame, housing four Magstar tape drives Model B1A.

The IBM 3590-A14 frame for integration in a Virtual Tape Server does not include the IBM 3590-A00 controller. You must order the IBM 3590-B1A tape drives separately.

The IBM 3590-B1A tape drives are not accessible by any host system and are for exclusive use of the Virtual Tape Server. All of the tape drives in the

| IBM 3590-A14 are dedicated to the Virtual Tape Server subsystem and
| cannot directly attach to a host system instead.

- One IBM 3495-B16 Virtual Tape Server unit frame including the tape volume cache and the VTS subsystem controller.

IBM Magstar VTS Host Software Support

0000 000000 000 0000
 00 00 00 0000 0000
 00 00000 00000000
 00 00 000000
 0000 000000 000 0000
 00 00 00 00000000
 00 00 000000000000
 0000 000000 000 0000
 00 00 00 000000000000

MVS Level	DFP (Requires BTLs)		DFSMS/MVS		
	3.3.0	3.3.2	1.1.0	1.2.0	1.3.0
4.2.2	✓	✓			
4.3.0	✓	✓	✓	✓	✓
5.1.0	✓	✓	✓	✓	✓
5.2.0			✓	✓	✓
5.2.2			✓	✓	✓

Environment	Min Levels
VM Guests	✓ VM/ESA 1.2
Native VM	✓ VM/ESA 1.2 DFSMS/VM 221
VSE Guests	✓ VM/ESA 1.2 DFSMS/VM 221 VSE/ESA 1.3.6
MVS and VSE	✓ EREP 3.5 +PTFs

✓ **IBM 3494 + 3495**
 ✓ **IBM 3494**



© IBM Corporation 1996

51227

Figure 74. IBM Magstar Virtual Tape Server Host Software Support

7.6 IBM Magstar Virtual Tape Server Host Software Support

The IBM Magstar Virtual Tape Server (VTS) appears to the host as two fully configured IBM 3490E tape subsystems. The software support is thus the same in the environments described below whether for a Virtual Tape Server subsystem included in IBM 3494 or one in IBM 3495.

7.6.1 MVS/ESA

The table on the left hand-side of Figure 74 shows the software requirements in an MVS/ESA environment.

In a system-managed tape environment, the following software levels are supported:

- MVS/ESA V4.3.0, V5.1.0, or V5.2.0
- JES3 Version V4.2.1, V5.1.1 or V5.1.2, if installed
- DFSMS/MVS V1.1.0, V1.2.0, or V1.3.0
- Environmental Record Editing and Printing (EREP) V3.5 plus PTF

If you are managing your IBM 3494 or 3495 tape library using Basic Tape Library Support (BTLs) for MVS/DFP (5655-057), the following software levels are supported:

- MVS/ESA V4.2.2, V4.3.0, or V5.1.0
- MVS/DFP V3.3.0 or V3.3.2

- EREP V3.5 plus program temporary fix (PTF)

If you are using BTLS for DFSMS/MVS (5655-056), the following software levels are required:

- MVS/ESA V4.3.0 or V5.1.0
- DFSMS/MVS V1.1.0, V1.2.0, or V1.3.0
- EREP V3.5 plus PTF

If you are using other 3490E emulations, such as Magstar tape drives attached to the host through the IBM 3591-A01 controller, you must install BTLS to allow the host to distinguish between native and emulated IBM 3490E devices.

7.6.2 VM/ESA

In a native VM/ESA environment, the Virtual Tape Server requires the following software levels:

- VM/ESA V1.2 or higher
- DFSMS/VM Function Level 221

For guest operating system support, VM/ESA V1.2. or higher must be installed, but DFSMS/VM is not required.

7.6.3 VSE/ESA

Native VSE/ESA does not support the IBM Magstar Virtual Tape Server (VTS). If VSE/ESA is running as a guest under VM, the following software levels are required for support of a Virtual Tape Server subsystem installed in an IBM 3494 tape library:

- VSE/ESA V1.3.5 or higher plus PTFs
- EREP V3.5 plus PTFs

Please note that the IBM Magstar Virtual Tape Server (VTS) in a IBM 3495 tape library is not supported for VSE/ESA, either native or running as a guest under VM.

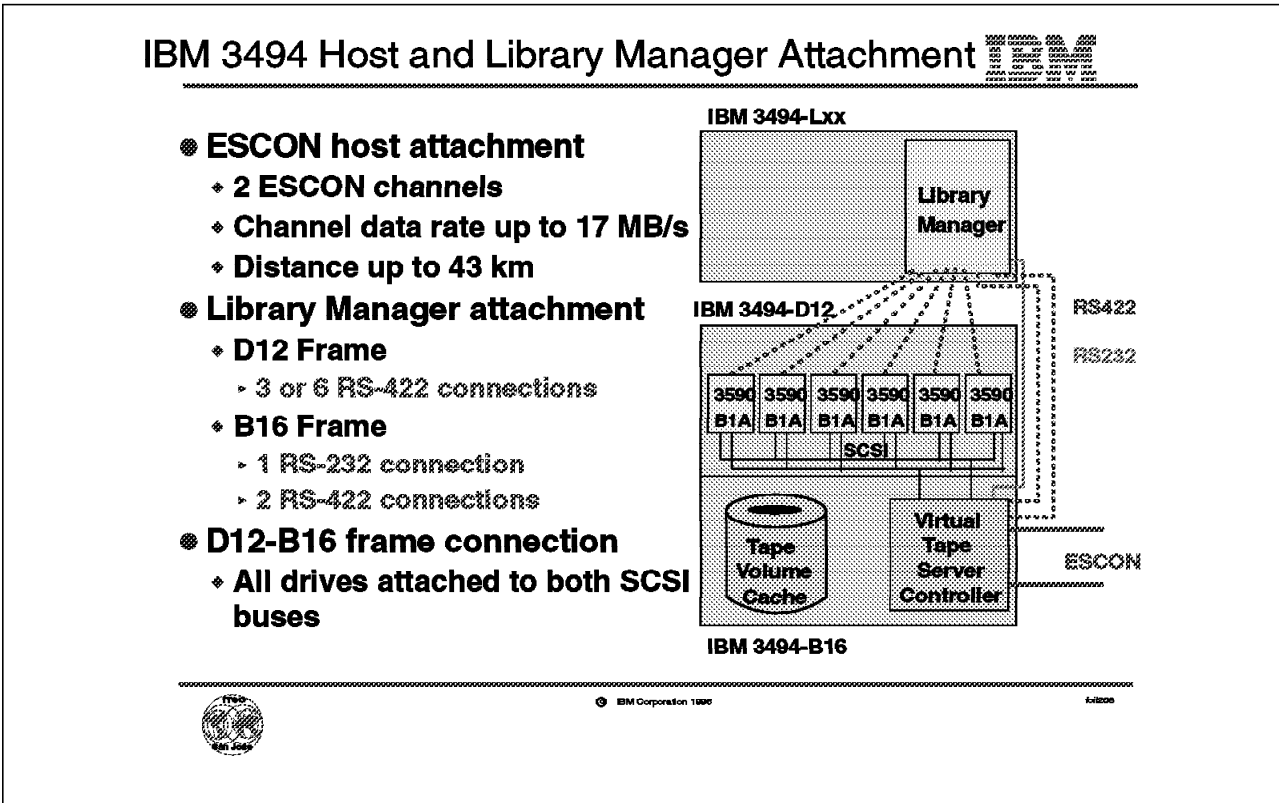

Figure 75. IBM 3494 Host and Library Manager Attachment

7.7 IBM 3494 Host and Library Manager Attachment

In Figure 75, we outline the integration of a Virtual Tape Server subsystem into an automated tape library through its attachments to the host and the Library Manager for an IBM 3494 tape library.

7.7.1 ESCON Host Attachment

The Virtual Tape Server subsystem is attached to the host through two ESCON channels, each providing 64 logical paths. Thus, the subsystem provides 128 logical paths in total.

Each ESCON channel provides a channel data rate of 17 MB/s instantaneous.

The Virtual Tape Server subsystem can be installed at the same distance of 43 km from the host as native Magstar tape drives.

All 32 virtual tape drives can be addressed through either ESCON channel.

7.7.2 Library Manager Attachment

The IBM 3590-B1A tape drives residing in the IBM 3494-D12 frame are not attached to any host system. They are attached solely to the Library Manager through an RS-422 connection to provide the required communication path for library-related commands, and to the Virtual Tape Server controller IBM 3494-B16.

The Virtual Tape Server controller is connected to the Library Manager through one RS-232 connection and two RS-422 connections to provide the required communication paths.

A total of five or eight RS-422 connections are required, depending on the number of Magstar tape drives installed in the Virtual Tape Server plus one RS-232 connection.

Without additional features installed on the library control-unit frame Models L10, L12, or L14, the library manager provides four RS-232 direct-attached host ports and four RS-422 control-unit or direct-attached drive connections. Currently, you need to order additional features for the IBM 3494 Model Lxx frames to provide the required Library Manager connections to the Virtual Tape Server subsystem.

Depending on the number of IBM 3590-B1A tape drives in the Virtual Tape Server controller (IBM 3494-B16) configuration and whether other control unit are installed in the IBM 3494, Feature 5229 and one or two Feature 5228 may need to be installed.

- If the IBM 3494-B16 contains three IBM 3590-B1A tape drives, up to an additional seven control units can be connected to the Library Manager with appropriate Features 5229 and 5228.
- If the IBM 3494-B16 contains six IBM 3590-B1A tape drives, up to an additional four control units can be connected to the Library Manager with appropriate Features 5229 and 5228.

7.7.3 IBM 3494-D12 and IBM 3494-B16 Frame Connections

All IBM 3590-B1A tape drives installed in the IBM 3494-D12 frame are connected to both SCSI buses of the Virtual Tape Server controller IBM 3494-B16. Because of this connection, both frames must be installed adjacent to one another.

IBM 3494 VTS Configuration Guidelines

0000 000000 000 0000
0000 000000 000 0000
00 00 00 0000 0000
00 00000 00000000
00000000 00000000
00 00 00 0000 00
0000 000000 000 0000
0000 000000 000 0000

- **D12/B16 frame must be inserted within the first eight frames**
- **D12 frame must always be left of the B16 frame**
- **D12 and B16 frames must directly attach to each other**
- **A modem must be supplied for the the B16 frame**
- **L12/L14 frames can be installed without drives**

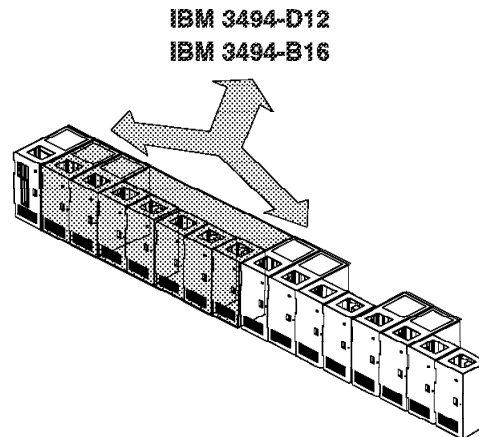

© IBM Corporation 1996

5/20/96

Figure 76. IBM 3494: VTS Configuration Guidelines

7.8 IBM 3494 Virtual Tape Server Configuration Guidelines

For physical configuration of an IBM 3494 Tape Library including the Virtual Tape Server, five basic configuration rules apply.

7.8.1 The L12/L14 Frame Can Be Without Drives

For a minimum configuration of an IBM 3494 with a Virtual Tape Server subsystem, the L12 or L14 frame can be installed without tape drives. Please submit an RPQ if you want to install a Model L10 frame without tape drives.

7.8.2 The D12/B16 Frame Must Be Within The First Eight Frames

If you are extending your current library to more than eight frames, you cannot install the Virtual Tape Server subsystem beyond the eighth frame.

If the configuration of frames in an installed IBM 3494 tape library has to be changed — for example, if frames must be moved to install a VTS subsystem, or if frames are moved from one IBM 3494 to another — an RPQ must be processed before the IBM 3494 Tape Library can be reconfigured. This RPQ is required for moving feature numbers 5300, 5302, 5304, and 5400, or Models B16, D10, D12, D14, and S10, and will ensure that the proper cables are available. The RPQ will also prepare for future changes or enhancements.

7.8.3 The D12 Frame Must Always Be to the Left of the B16 Frame

If you are planning to use an already installed IBM 3494-D12 frame to hold the IBM 3590-B1A tape drives of the Virtual Tape Server, it has to be installed to the left of the IBM 3494-B16 frame (between the IBM 3494-B16 and the IBM 3494-Lxx frames). If you want to change an existing empty IBM 3494-D14 frame into an IBM 3494-D12 frame, you must submit an RPQ.

7.8.4 The D12 and B16 Frames Must Directly Attach to One Another

You cannot install another frame between the IBM 3494-D12 and the IBM 3494-B16 frames that include an IBM Magstar Virtual Tape Server (VTS).

7.8.5 A Modem Must Be Supplied for the IBM 3494-B16 Frame

It is mandatory that you supply a modem for installation, operation, and remote support service of the IBM 3494-B16 frame. The same modems as for the IBM 3591-A01 and 3590-A00 Remote Support Facility (RSF) are supported. You can obtain a list of these modems from your IBM representative.

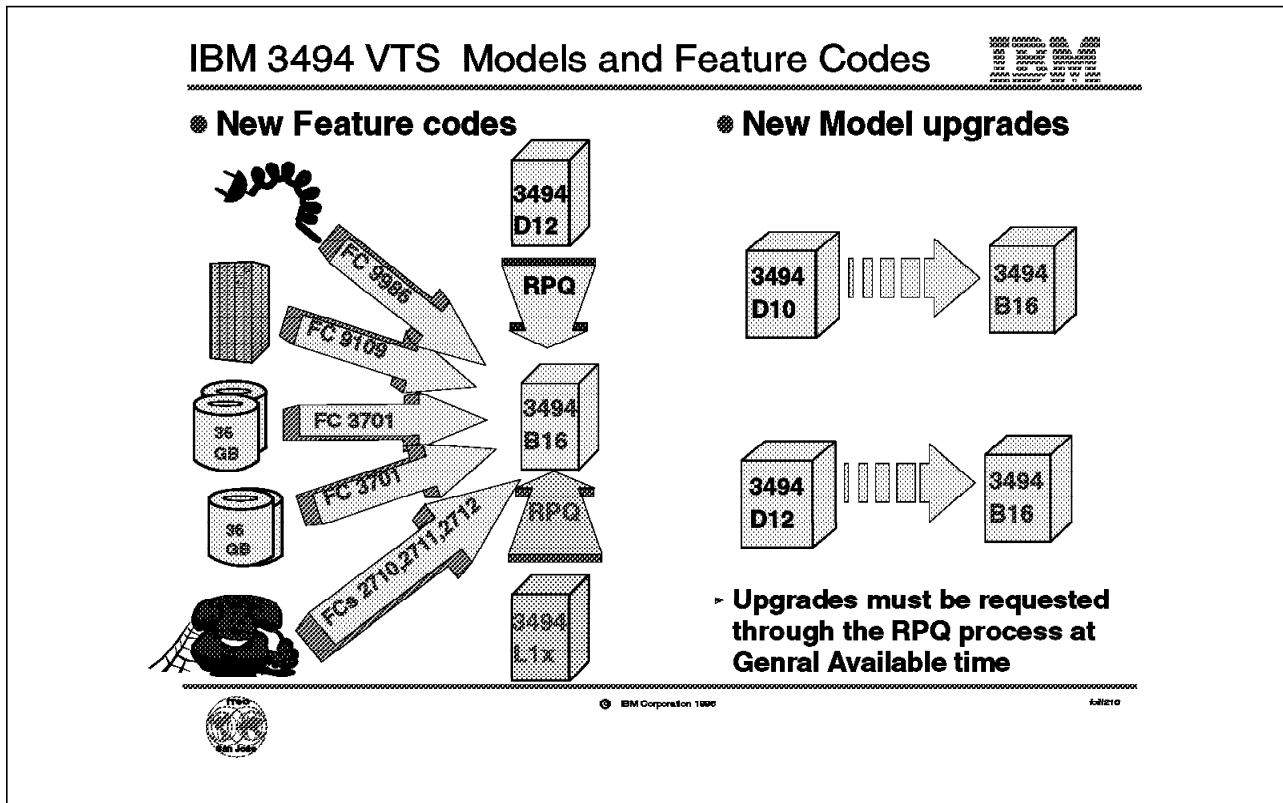

Figure 77. New IBM 3494 Features, Their Codes and Model Upgrades

7.9 New IBM 3494 Features, Their Codes and Model Upgrades

For integration of an IBM Magstar Virtual Tape Server (VTS) into an existing IBM 3494, or for factory installation, you must order the features listed below. To use an existing IBM 3494 frames for installation of a Virtual Tape Server subsystem.

7.9.1 Features and Their Codes

To install an IBM 3494 plus IBM Magstar Virtual Tape Server (VTS), you must order some new features in addition to existing features and products. For instance, the IBM 3590-B1As that are installed inside the IBM 3494 Model D12 frame must be ordered separately.

7.9.1.1 IBM 3494 Model D12 plus Feature 9010

Feature 9010 for the IBM 3494 Model D12 frame indicates that the IBM 3590 tape drives in it are to be used by a Virtual Tape Server subsystem.

7.9.1.2 IBM 3494 Model L1x plus Feature 9006

To add an IBM 3494 Model B16 frame to a library, one feature 9006 must be specified for the library unit frames L10, L12, or L14 to track the number of frames installed in the library.

Note: Additional Library Manager connections are currently required for the installation of the Virtual Tape Server in an IBM 3494 tape library. Please refer to Section 7.7, "IBM 3494 Host and Library Manager Attachment" on page 165 for details about feature codes 5228 and 5229.

7.9.1.3 IBM 3494 Model B16 Feature Codes

Feature 9109 must be specified for the IBM 3494 Model B16 frame to specify its connection to the S/390 host systems.

Feature 9986 is required to provide a special line cord for Chicago, Illinois, U.S.A.

Feature 3701 provides the DASD storage for the tape volume cache. Each feature includes two DASD arrays providing you with 36 GB of usable tape volume cache. Currently, you can order either one or two Features 3701:

- Order one Feature 3701 if three IBM 3590-B1As are installed in the Virtual Tape Server subsystem.
- Order two Features 3701 if six IBM 3590-B1As are installed in the Virtual Tape Server subsystem.

It is required that you supply a modem for installation, operation, and remote support service of the Model B16 frame and that you install one of the following features code. The same modem and switch may be shared between an IBM 3494 Model B16, and an IBM 3590 Model A00.

2710 Remote Support Facility

This feature supplies a cable and connectors to attach a customer-supplied modem to the IBM 3494 Model B16 for remote diagnostic support. This feature should be specified only on the first IBM 3494 Model B16, or IBM 3590 Model A00 in an installation, as the Model B16s and Model A00s can use the same Remote Support Facility. Each IBM 3494 Model B16 must specify either Feature 2710, 2711, or 2712.

2711 Remote Support Switch

This feature provides a switch, cables, and connectors for the attachment of a IBM 3494 Model B16, and one or more 3590 Model A00 Controllers to the Remote Support Facility (Feature Code 2710). It should be ordered on a IBM 3494 Model B16, IBM 3495 Model B16, or IBM 3590 Model A00 that is the second product in an installation. Only one switch should be specified per installation site. Each IBM 3494 Model B16 must specify Feature 2710, 2711, or 2712.

2712 Remote Support Attachment

This feature provides an additional cable and connector to attach to the Remote Support Switch (feature code 2711). Order it on the IBM 3494 Model B16, or IBM 3590 Model A00 — that is, the third through fourteenth product in the installation. Each 3494 Model B16 must specify Feature 2710, 2711, or 2712.

Features 2710, 2711 and 2712 are both plant and field installable.

7.9.2 Model Upgrades

You must apply for an RPQ if you wish to upgrade an existing IBM 3494 Model D10 or D12 frame to an IBM 3494 Model B16 frame. The following Model conversions may be supported:

- IBM 3494 Model L10 to L12
- IBM 3494 Model L10 to L14

- IBM 3494 Model D10 to D12
- IBM 3494 Model D10 to D14
- IBM 3494 Model D10 to B16
- IBM 3494 Model D12 to B16
- IBM 3494 features 5300 to 5302
- IBM 3494 features 5300 to 5304

If you want to upgrade one or two existing frames to a D12+B16 frame combination and the model upgrades are not listed, also please submit an RPQ.

IBM 3494 VTS Environmental Requirements

IBM 3494 VTS Environmental Requirements

● Operating Environment

Condition	Temperature	Relative Humidity
Operating	10 to 37.0 C	20 to 80%
Nonoperating	10 to 51.7 C	8 to 80%
Storage	1 to 60.0 C	5 to 80%
Shipping	-40 to 60.0 C	5 to 100%

● Virtual Tape Server Specifications

Frame	Weight	Heat Output	Airflow	Max. Power
	*			
D12 + 3xB1A	405.8 kg	1.00 kw	3.9 qm/min	1.2 kVA
D12 + 6xB1A	491.6 kg	1.90 kw	7.8 qm/min	2.10 kVA
B16	450.0 kg	1.41 kw		2.16 kVA (1.83kVA)

* all weights assume no cartridges are installed in the 3494 frame.



© IBM Corporation 1996

52811

Figure 78. IBM 3494 Environmental Requirements

7.10 IBM 3494 Environmental Requirements

Figure 78 lists the physical specifications for the operation environment of an IBM 3494 tape library and the specifications for the Virtual Tape Server in IBM 3494.

The dimensions of the IBM 3494 Model B16 frame are the same as for every other IBM 3494 frame:

- Height: 1800 mm (70.9 in)
- Width : 750 mm (29.5 in)
- Depth : 1524 mm (60.0 in)

For further information on the Virtual Tape Server subsystem's physical installation please refer to *IBM 3494 Tape Library Dataserver Introduction and Planning Guide*.

IBM 3495 VTS Configuration Guidelines

- One IBM 3495-B16 is required
- One IBM 3590-A14 frame is required
 - ◆ Four IBM 3590-B1A tape drives
 - ◆ No IBM 3590-A00 controller
- B16 and A14 frames must be installed adjacent to each other
- A modem must be supplied for the IBM 3495-B16

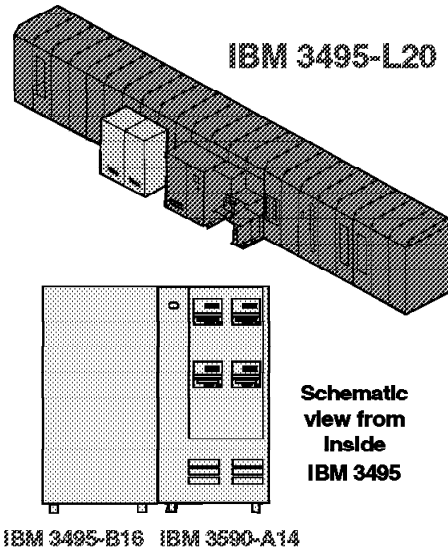

© IBM Corporation 1996

54812

Figure 79. IBM 3495 Virtual Tape Server Configuration Guidelines

7.11 IBM 3495 Virtual Tape Server Configuration Guidelines

For physical configuration of an IBM 3495 Tape Library including the Virtual Tape Server, the following basic configuration rules apply:

7.11.1 One IBM 3495-B16 Must Be Installed

The IBM 3495-B16 provides the ESCON connection to the host, and houses the tape volume cache and the Virtual Tape Server controller. In the IBM 3495 wall adjacent to the 3495-B16 storage cells can still exist, as is with the IBM 3490-Axx installed in an IBM 3495. These storage cells, which are managed by the Library Manager, can contain any cartridge and are not restricted to storing only Magstar cartridges that are used by Virtual Tape Server subsystem

7.11.2 One IBM 3590-A14 Frame Must Be Installed

One IBM 3590-A14 frame is required for the Virtual Tape Server subsystem. It contains four IBM 3590-B1As plus the necessary SCSI cabling to connect the tape drives to the IBM 3495-B16. Other than with ESCON-attached IBM 3590 tape drives the IBM 3590-A14 frame used by a Virtual Tape Server does not require an IBM 3590-A00 control unit to be ordered.

You must order the IBM 3590-B1As in addition to the IBM 3590-A14 frame. However, you do not need to specify SCSI cables for the tape drives.

7.11.3 Library Manager Attachment

The Magstar tape drives residing in the IBM 3495-D12 frame are not attached to any host system. The drives are managed by the Virtual Tape Server controller. None of the IBM 3495 Library Manage RS-422 control unit ports are used by the VTS subsystem. They are attached solely to the Library Manager through a LAN connection to provide the required communication path for library-related commands, and to the Virtual Tape Server controller IBM 3495-B16.

The Virtual Tape Server controller is connected to the Library Manager through a dedicated LAN connection to provide the required communication paths.

7.11.4 IBM 3495-B16 and IBM 3590-A14 Must Be Installed Side by Side

The IBM 3495-B16 and the IBM 3590-A14 must be installed adjacent to one another. You cannot separate the two frames.

7.11.5 Reduction of IBM 3495 Storage Cells when a VTS is Installed

When a VTS is installed in an IBM 3495, the total amount of storage cells in the library may be decreased. If it is placed in a location where a 3490 subsystem already existed, the cell count is not affected. If the VTS is installed on an IBM 3495 Model L30, L40 or L50 in a position where no IBM 3490 string existed, then the cell count will drop by 520 tapes (two IBM 3495 storage racks, no reduction in the frame adjacent to the B16 frame).

7.11.6 A Modem Must Be Supplied for The IBM 3495-B16

It is mandatory that you supply a modem for installation, operation, and remote support service of the IBM 3495-B16. The same modems as for the IBM 3591-A01, and 3590-A00 Remote Support Facility (RSF) are supported. You can obtain a list of these modems from your IBM representative.

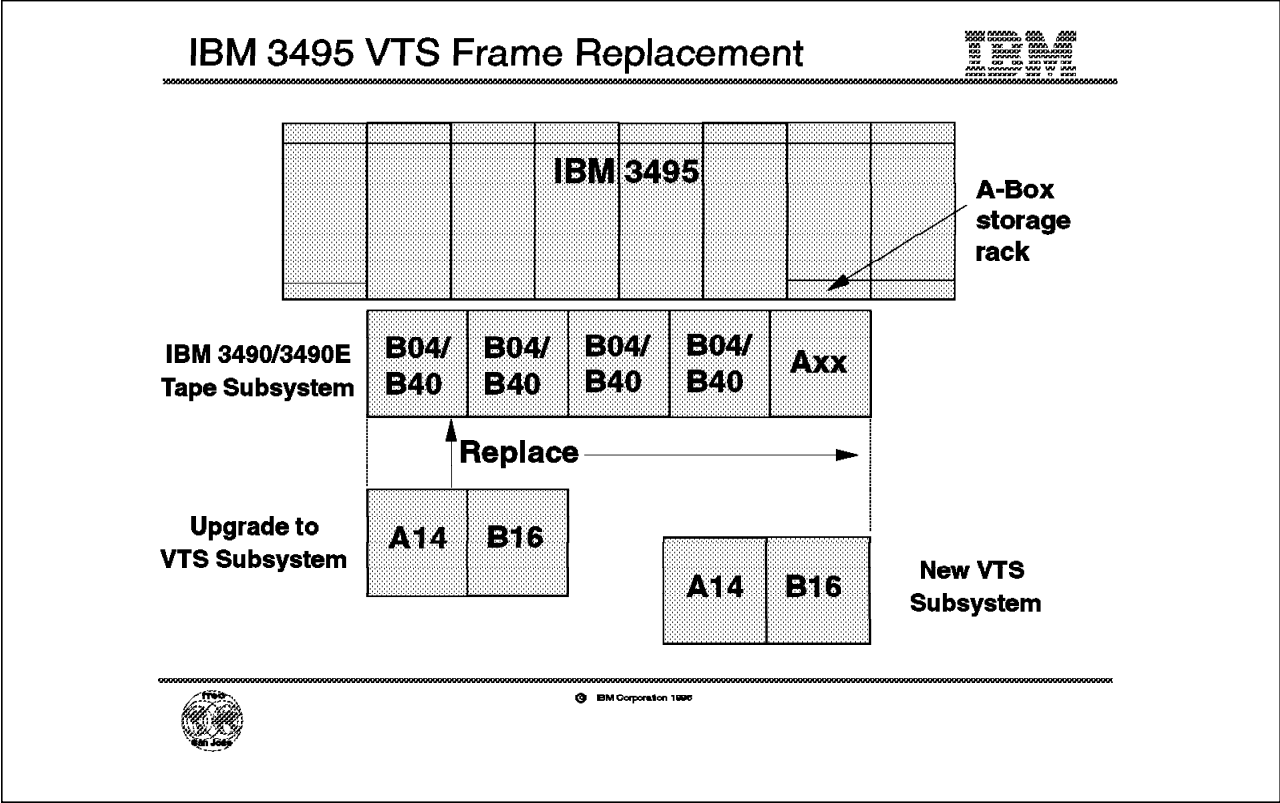

Figure 80. IBM 3495 Virtual Tape Server Frame Placement

7.12 IBM 3495 Virtual Tape Server Frame Placement

Each VTS subsystem is integrated into an IBM 3495 library through the installation of an IBM 3495-B16 and an adjacent IBM 3590-A14 frame. The IBM 3590-A14 frame must be installed to the left of the IBM 3495-B16 frame (when viewed from the front of the library) and must have no other frame between it and the IBM 3495-B16.

The two frames can be located along the library aisle wherever IBM 3490 or 3590 tape subsystems can be installed. Figure 80 shows where the A14/B16 frames can be installed relative to where the IBM 3490 frames are installed. If the VTS is being installed and replaces part of an existing IBM 3490 subsystem, it is installed to the left of the remaining IBM 3490 frames. If the VTS is replacing the entire IBM 3490 tape subsystem or is being installed where there was no previous IBM 3490 tape subsystem, the rightmost edge of the IBM 3495-B16 frame is placed on the IBM 3495 frame boundary. This similar to IBM 3490-Axx frame placement rules.

If a VTS replaces an existing IBM 3490 tape subsystem, the existing "A" box cartridge rack is left in place, even though there is no front service access requirement for the IBM 3495-B16 frame. It is suggested that a filler cover be installed in the hole in this frame.

The maximum number of VTS subsystems per physical IBM 3495 library is four. At the initial GA of VTS on the IBM 3495, only one VTS is supported per IBM 3495.

| The VTS subsystem controller uses the LAN attachment method to communicate
| with the Library Manager. This leaves all existing eight control-unit attachment
| ports (RS422) into the LM available to connect to IBM 3490 subsystems and IBM
| 3590-A00 attached IBM 3590 tape subsystems.

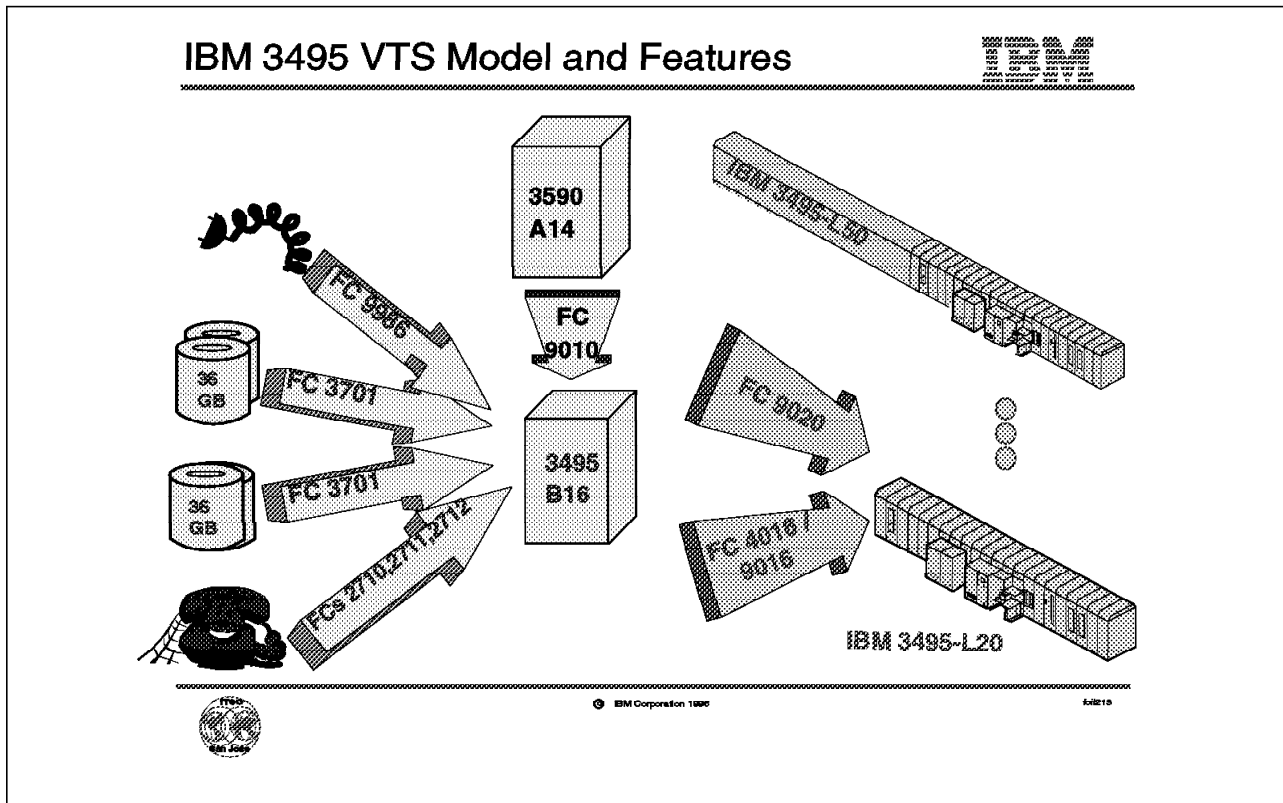

Figure 81. IBM 3495 Virtual Tape Server Models and Features

7.13 IBM 3495 Virtual Tape Server Models and Features

For integration of an IBM Magstar Virtual Tape Server (VTS) into an existing IBM 3495, or for factory installation, you must order the features using the codes listed below.

To install an IBM 3495 plus IBM Magstar Virtual Tape Server (VTS), you must order the new features in addition to existing features and products. For instance, the IBM 3590-B1As that are installed inside the IBM 3590-A14 frame must be ordered separately. We list only the additional features that are required to include the Virtual Tape Server in the IBM 3495.

7.13.1 IBM 3590 Model A14 Plus Feature 9010

Feature 9010 for the IBM 3590-A14 frame indicates, that the IBM 3590 tape drives in it are to be used by a Virtual Tape Server subsystem.

7.13.2 IBM 3495 Model B16 Feature Codes

Feature 9986 is required to provide a special line cord for Chicago, Illinois, U.S.A.

Feature 3701 provides the DASD storage for the tape volume cache. Each feature provides you with 36 GB of usable tape volume cache. Currently, you can order either one or two Features 3701.

In addition to the modem you must supply for installation, operation, and remote support service of the IBM 3495-B16, you must install one of the following features:

- 2710** Remote Support Facility
- 2711** Remote Support Switch
- 2712** Remote Support Attachment

For detailed information on the features and their codes, please refer to Section 7.9, "New IBM 3494 Features, Their Codes and Model Upgrades" on page 169.

7.13.3 Feature Codes For IBM 3495 Model L20, L30, L40 and L50

When a Virtual Tape Server is installed in an IBM 3495, Feature 9020 must be specified for the tape library. This feature provides the hardware and microcode for the Library Manager to VTS controller communication path.

For a plant-installed IBM 3495-B16, you must order Feature 9016; for field installation, order Feature 4016.

IBM 3495 VTS Environmental Requirements

0000 000000 000 000
 00 00 00 0000 0000
 00 00000 00000000
 00 00 000000
 00 00 00000000
 0000 000000 000 000
 00 00 00 0000 0000
 00 00000 00000000
 00 00 000000
 00 00 00000000
 0000 000000 000 000
 00 00 00 0000 0000
 00 00000 00000000
 00 00 000000

● Operating Environment

Condition	Temperature	Relative Humidity
Operating	10 to 37.0 C	20 to 80%
Nonoperating	10 to 51.7 C	8 to 80%
Storage	1 to 60.0 C	5 to 80%
Shipping	-40 to 60.0 C	5 to 100%

● Virtual Tape Server Specifications

◆ IBM 3495-B16 Frame

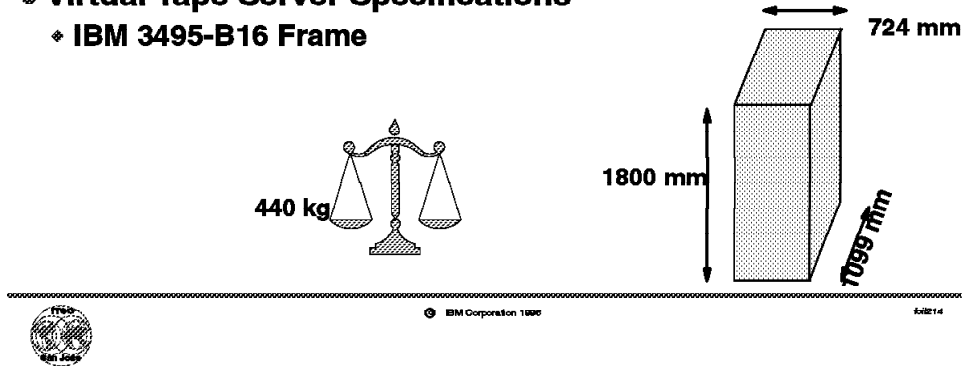

Figure 82. IBM 3495 Environmental Requirements

7.14 IBM 3495 Environmental Requirements

Figure 82 lists the physical specifications for the operation environment of an IBM 3495 tape library and the specifications for the Virtual Tape Server in the IBM 3495.

For further information on the Virtual Tape Server subsystem's physical installation please refer to *IBM 3495 Tape Library Dataserver Introduction and Planning Guide*.

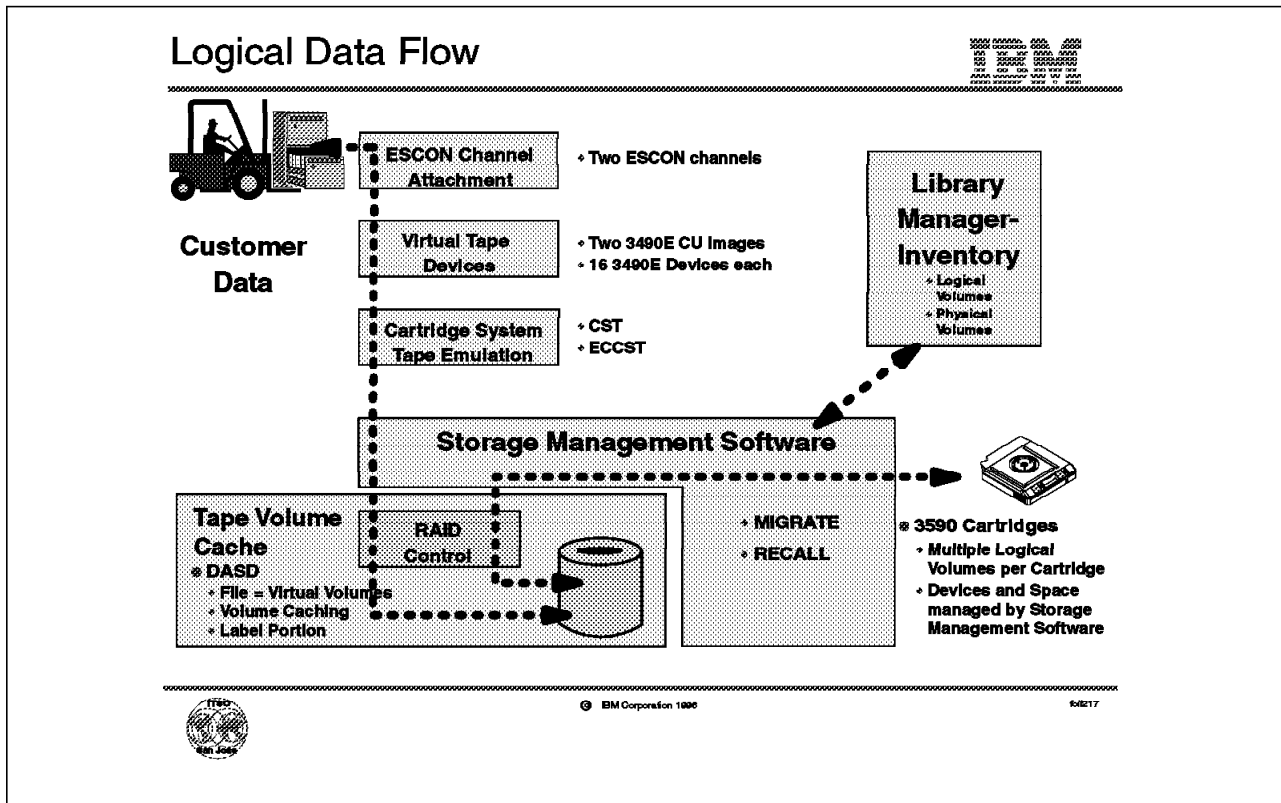

Figure 83. Logical Data Flow

7.15 Logical Data Flow

Figure 83 shows the logical data flow through an IBM Magstar Virtual Tape Server (VTS) subsystem.

The host system has knowledge about the following components and interfaces that allow it to write data onto tape:

ESCON channel attachment: The host knows that there are two ESCON channels to the (virtual) 3490E tape drives. Either ESCON channel can access all virtual tape drives.

Virtual tape devices: The host sees two IBM 3490E control unit images, each of them fully configured with 16 tape drives for a total of 32 virtual 3490E tape drives.

Cartridge system tape emulation: The host can use virtual CST or ECCST media to store its data.

Library Manager: Through the Library Manager, the host is informed about logical volumes available in the IBM 3494 or 3495 tape library, their status, and status changes as well as about the status of the virtual devices.

The physical storage and management of the data written by the host is invisible to the host and its applications.

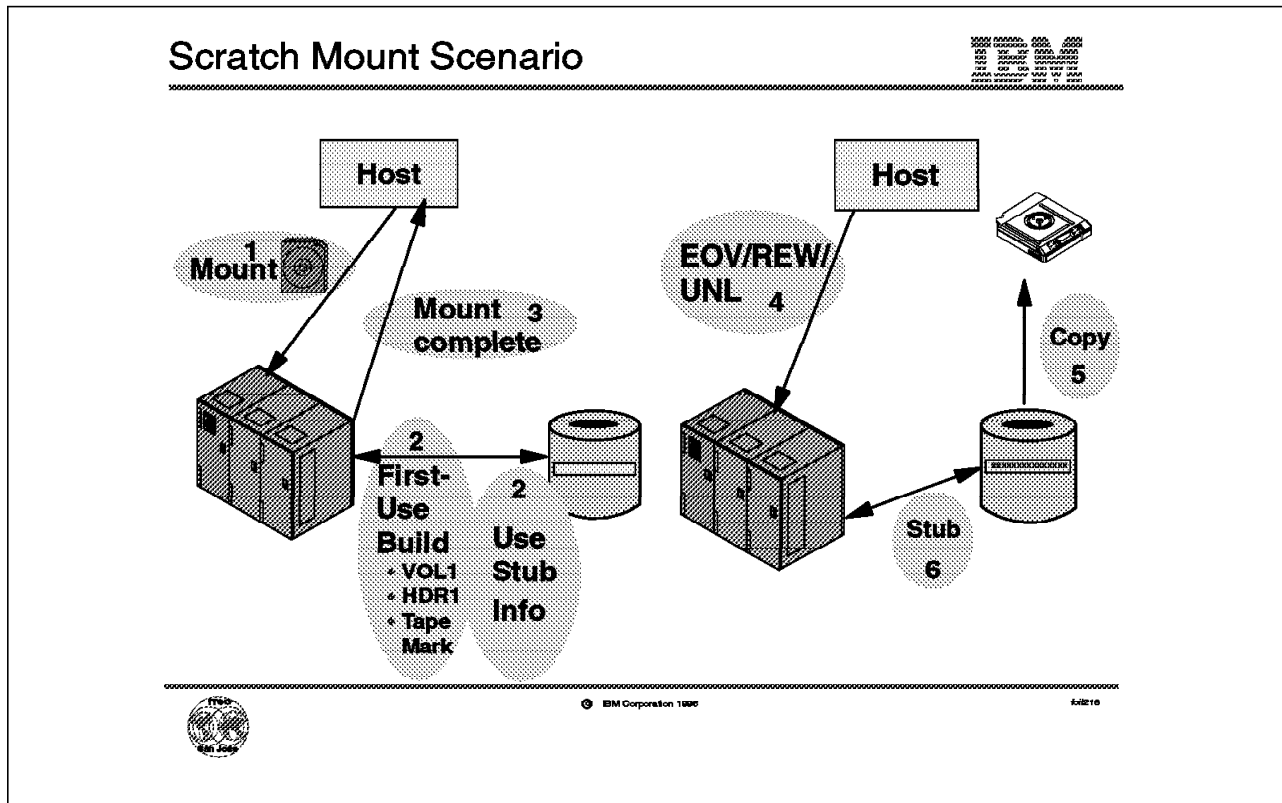

Figure 84. Scratch Mount Scenario

7.16 Scratch Mount Scenario

The Virtual Tape Server has special facilities for handling scratch (nonspecific) type mount. With the following facilities, the Virtual Tape Server processes scratch-mount requests in a fast and efficient manner.

- Virtual Volume Use Information.

After the first usage of a volume serial number as a virtual volume, information about that usage is maintained in the Tape Volume Cache even though most of the volume's data has been moved onto a Magstar cartridge into a logical volume. This portion of the data from the last usage of the volume is called the stub and includes the first several hundred bytes of data written during the last use of the volume. The information includes at least the data records that include a tape label.

- Automatic Initialization of a virtual volume on its first use.

Prior to the first use of a volume serial number as a virtual volume, the Tape Volume Cache will not have any information about the previous use of the volume. When the volume is mounted for the first time, the Storage Management Software will generate a set of records for the volume in the Tape Volume Cache as if the volume had been initialized using EDGINERS or IEHINITT specifying an IBM standard label, that is the volume will contain a VOL1, HDR1 and Tape Mark.

- Outboard Management of Volume Pools (Categories).

The IBM Tape Libraries, along with host software, provide a facility to have the Library Manager manage groups of volumes in pools. The pools are

called Categories and the host can assign one or more volumes to a category and later ask for a mount of a volume from the category. The Library Manager, on receiving a mount from category request, will select a volume from the specified category and make it ready on a tape device. As part of the operation to make the volume ready on a tape device, the Library Manager passes the volume serial number of the volume mounted back to the host software. Through the use of categories, the Library Manager can maintain a set of volumes that can be used for scratch mounts. Depending on the host software support at least two categories are used for scratch mounts, one for Media Type 1 - Standard Cartridge System Tape and one for Media Type 2 - Enhanced Capacity Cartridge System Tape.

- Fast-Ready Attribute for Categories

With the introduction of the Virtual Tape Server, an attribute can be assigned to a category that allows the Storage Management Software in the Virtual Tape Server to know that it can use the last usage information maintained in the Tape Volume Cache to process a nonspecific mount instead of having to recall the complete logical volume for the selected volume from a Magstar cartridge. The attribute for a specific category is set by the operator through a panel on the Library manager.

- Logical Volume Data Invalidation

Like a physical volume, the data that resides in a logical volume is accessible until two things happen. First, the Tape Management System determines that the data on the volume has expired and returns the volume to a scratch pool. Second, the volume is mounted in response to a scratch mount request and new data is written on the volume from the beginning of tape. The Storage Management Software in the Virtual Tape Server maintains a database to where the current accessible version of a logical volume is located on the IBM 3590 tape cartridges that it manages. This is done independent of whether the Tape Management System has returned the volume to a scratch pool or not. It is only when the volume serial number of the logical volume is reused as a virtual volume and modified, either from the beginning of tape or in an append operation, that the old location of the logical volume is deleted and the space it represents marked as invalid. When the new version of the logical volume is migrated to a Magstar cartridge, it will be in a different location on a different cartridge.

A nonspecific mount request for the first time a volume serial number is used is processed with the following steps:

1. The host sends a mount request for a scratch cartridge by specifying the category that contains either CST or ECCST volumes. The categories have the Fast-Ready attribute set. The Library Manager selects a logical volume serial number to satisfy the mount request.
2. The Storage Management Software in the Virtual Tape Server checks whether the selected volume has prior usage information in the Tape Volume Cache. Since this is the first usage of the volume, there will not be any information. The Storage Management Software will create that information including the data records for a VOL1, HDR1 and tape mark.
3. Mount complete is signaled to the host which then can write data to the virtual volume. Since there was no physical mount of a volume required, the nonspecific mount request is handled much faster than in a conventional tape library.

4. When the host closes the volume, End-of-Volume (EOV) processing is performed, and the volume is rewound and unloaded.
5. After the volume is unloaded, the virtual volume is scheduled to be copied onto a physical IBM 3590 cartridge.
6. After it is copied, the virtual volume remains in the Tape Volume Cache until the space it occupies is needed for other virtual volumes. When a virtual volume's space is needed, most of the volume's data is deleted, leaving a small portion stub of the volume's data. That stub has enough space to include the VOL1, HDR1 and HDR2 records, URL1 through URL8 records if present and a tape mark. Selection of when a virtual volume is stubbed in the Tape Volume Cache is through a Least Recently Used (LRU) algorithm.

After the host has expired the data on the logical volume, it becomes a scratch volume again and can be selected by the Library Manager in response to a mount request for a scratch volume.

A nonspecific mount request for a subsequent use of a volume serial number is processed with the following steps:

1. The host sends a mount request for a scratch cartridge by specifying the category that contains either CST or ECCST volumes. The categories have the Fast-Ready attribute set. The Library Manager selects a logical volume serial number to satisfy the mount request.
2. The Storage Management Software in the Virtual Tape Server will find that the selected volume has prior usage information in the Tape Volume Cache. This information contains all of the data records that the host Tape Management Software needs to validate the usage of the volume for a nonspecific mount request.
3. Since the volume was selected from a category that had the Fast-Ready attribute set, the Storage Management Software signals the host that the mount is complete without having to recall all of the data from the last usage of the volume from a physical cartridge. This results in a very low mount-response time since no physical movement or mounting of a cartridge is involved.
4. Same as in the first usage of a volume serial number.
5. After the volume is unloaded, the virtual volume is scheduled to be copied onto a physical 3590 tape cartridge. It is at this point that the last version of the data associated with the volume serial number is invalidated.
6. Same as in the first usage of a volume serial number.

Specific Mount Scenario

• Volume in TVC

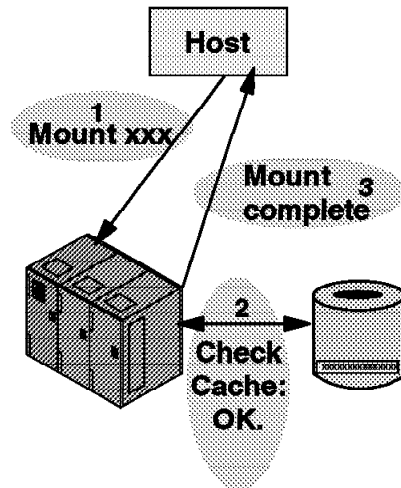

• Volume not in TVC

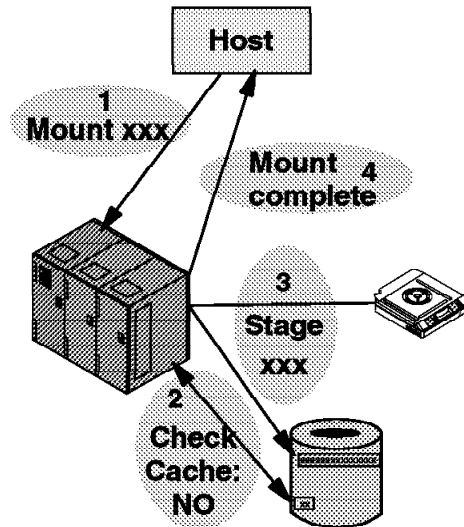

© IBM Corporation 1996

52216

Figure 85. Specific Mount Scenario

7.17 Specific Mount Scenario

When the host requests a specific logical volume, and the virtual volume exists in the tape volume cache, no physical mount is required to access this volume. If the tape volume cache contains only the usage information stub, the logical volume has to be staged to the tape volume cache first and become a virtual volume before the host can process it.

7.17.1 Volume in Tape Volume Cache

In case the virtual volume resides in the tape volume cache, the host can process the volume almost immediately, allowing very fast mount-response times.

7.17.2 Volume not in Tape Volume Cache

If the logical volume resides only on tape, it must be staged to the tape volume cache first. This involves a physical mount, positioning the tape and copying the logical volume to the tape volume cache. Mount complete is signaled to the host system only after the complete volume is available in the tape volume cache.

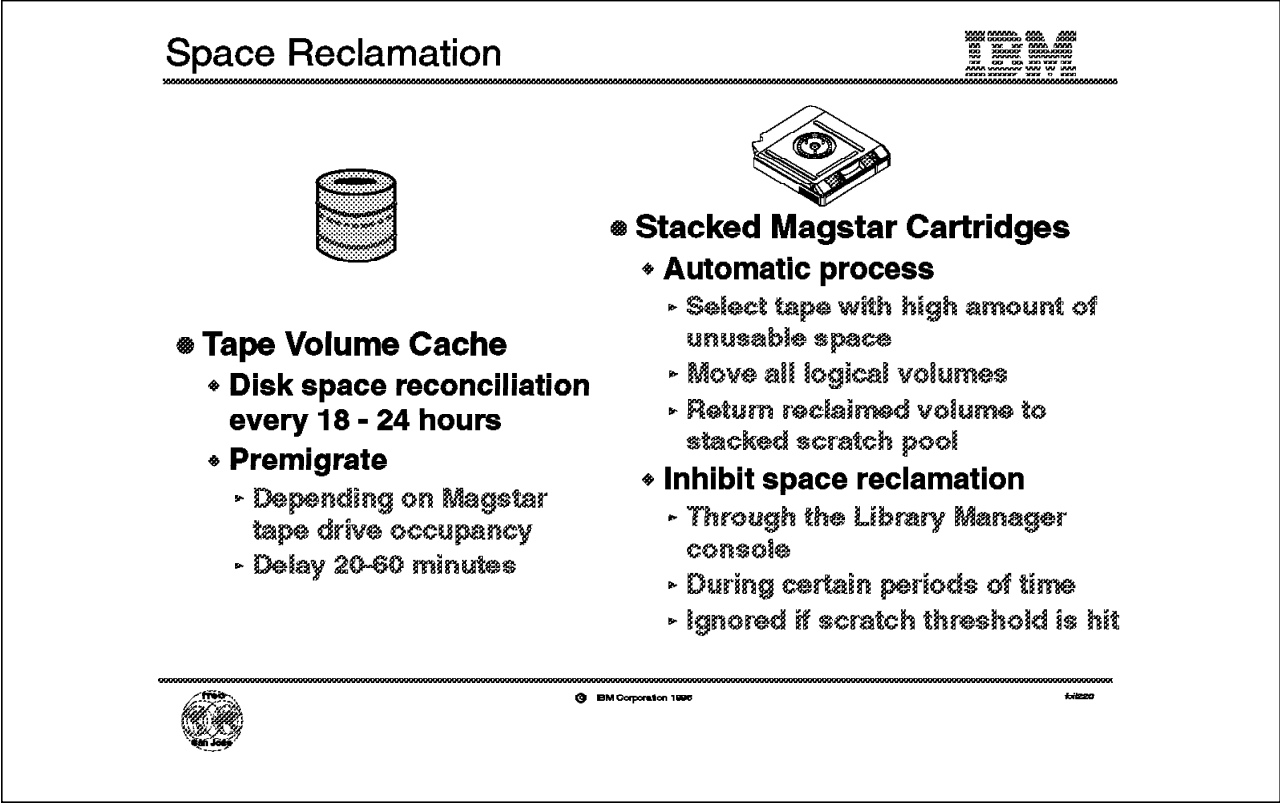

Figure 86. Space Reclamation

7.18 Space Reclamation

In the IBM Magstar Virtual Tape Server (VTS), two levels of physical storage are managed automatically: the tape volume cache to free up DASD space, and the Magstar cartridges to free up tape space.

7.18.1 Tape Volume Cache

The tape volume cache is under complete and exclusive control of the Virtual Tape Server subsystem. There are no external interfaces to influence the management of the tape volume cache.

Disk space reconciliation for the tape volume cache is performed about once per day, which is every 18 to 24 hours depending on the Virtual Tape Server subsystem's workload and on occupancy of the Magstar tape drives.

Copying of a virtual volume onto a Magstar Cartridge is scheduled after the volume is rewound and unloaded. It is very likely that the virtual volume is copied during the following 20 to 60 minutes.

Once a virtual volume has been copied onto a Magstar cartridge, it becomes a candidate for being reduced to its usage information stub to make space available in the Tape Volume Cache space for other virtual mount requests. Candidates for reduction are managed with a Least Recently Used (LRU) algorithm meaning that, when space is needed, volumes that have been in the Tape Volume Cache the longest without being accessed are reduced until

enough space is freed up. Access includes when a virtual volume is read from as well as when written to.

7.18.2 Stacked Magstar Cartridges

When the data associated with a specific volume expires through the policies of the tape management system, the volume is returned to scratch. As part of the expiration process, DFSMSrmm (removable media manager) for example automatically notifies the Library Manager about the status change of the volume.

7.18.2.1 Logical Volume Space Use

With a Virtual Tape Server subsystem, the volume is a logical volume and resides on a stacked Magstar cartridge along with other logical volumes. When a logical volume is returned to a scratch pool, it becomes eligible to satisfy a nonspecific mount request. When the volume is next selected and written to, the space associated with the previous use of the logical volume on the Magstar cartridge becomes unusable, meaning it no longer contains valid active data and cannot be accessed or used.

Returning a volume to a scratch pool is not the only way space on a stacked Magstar cartridge becomes unusable. Any time a volume is modified, the space occupied by the previous use of the volume becomes unusable.

The reason the space becomes unusable is twofold.

1. As with other prior tape technology, the Magstar tape drive does not support writing data between two areas of valid data. The reason for this is that the valid data in the area directly after the newly written data may be partially overlaid.
2. The next time the logical volume is used, it may contain a greater number of bytes and would not fit on the tape.

Over a period of time, the amount of unusable space on a Magstar cartridge will grow until it becomes a large percentage of the total space of the cartridge. The reclamation of that unusable space, converting it to usable space, is part of the management responsibilities of the Virtual Tape Server.

7.18.2.2 Automatic process

Space management of the stacked 3590 cartridges is performed automatically without any external direction. The storage management software in the Virtual Tape Server monitors the utilized space on the 3590 cartridges that it manages and determines when a cartridge is a candidate to have its unusable space reclaimed. The reclamation process requires a portion of the resources of a Virtual Tape Server subsystem and as such can impact host usage of the subsystem. To minimize any impact, the storage management software in the Virtual Tape Server monitors how much of the subsystem resources are in use because of host processing and will normally perform reclamation processing in mostly idle periods.

In addition, you can specify through the Library Manager console during which time periods reclamation is normally not to be performed.

The above rules for when reclamation processing is performed are dependent on a threshold number of available scratch stacked 3590 cartridges. The dependencies are:

- There are fewer than 50 scratch stacked 3590 cartridges

If the number of available scratch stacked 3590 cartridges falls below 50, reclamation processing will be performed until it is again above 50 except for the time periods set through the Library Manager console. Host usage of the subsystems resources is ignored and may be impacted.

- There are fewer than 10 scratch stacked 3590 cartridges

If the number of available scratch stacked 3590 cartridges falls below 10, reclamation processing will be performed until it is again above 10. Host usage of the subsystems resources and any time period limits set through the Library Manager console are ignored.

Reclamation of unusable space involves the following general steps:

1. Selecting tape with a high amount of unusable space
2. Move all of the valid logical volumes on the selected stacked 3590 cartridge to another 3590 cartridge, restacking them end to end. The end result is a contiguous space from the end of the last valid logical volume (which could be the beginning of the stacked volume) to the logical end of tape of the stacked Magstar cartridge.
3. Returning the now empty stacked 3590 cartridge to the stacked volume scratch pool.

Virtual to Physical Volume Comparison

- **Virtual volume**
 - ◆ **Uncompressed size**
 - ◆ **Emulated CST = 400 MB**
 - ◆ **Emulated ECCST = 800 MB**
- **Physical volume**
 - ◆ **Magstar 3590 cartridge**
 - ◆ **+30 GB**
 - ◆ **Compression while data is destaged**
- **Virtual volume advantages**
 - ◆ **Short mount response time**
 - ◆ **Fast tape-motion commands**
 - ◆ **Random access**
 - ◆ **Cache volume reaccess**

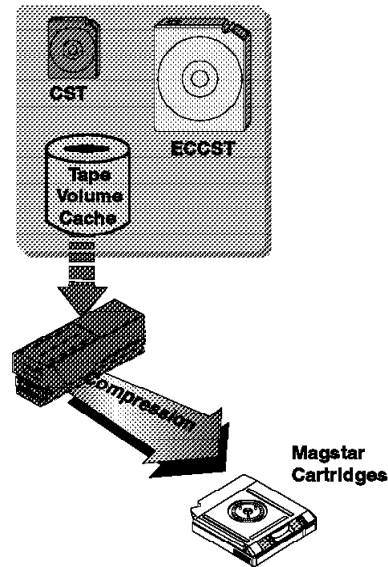

Figure 87. Comparison of Virtual to Real Volumes.

7.19 Virtual to Real Volume Comparisons

In this section we compare the virtual volumes to real or physical volumes and list the advantages of the Virtual Tape Server implementation through 3490E emulation.

7.19.1 Virtual Volume

When the host application selects a tape, it can define whether it wants a media type of MEDIA1 or MEDIA2 to be used by using an appropriate data class. For example, if a volume residing in a Virtual Tape Server subsystem is selected, a virtual volume is created. A virtual volume is an emulated CST cartridge when MEDIA1 is selected, or ECCST when MEDIA2 is selected.

7.19.1.1 Uncompressed Size

The Virtual Tape Server controller does not have the hardware compression feature that allows a real 3490 device to store more data than the amount specified below on a single logical volume.

This might result in more multivolume files when migrating from real to emulated 3490E cartridges.

7.19.1.2 CST = 400 MB

The emulated CST cartridge stores up to 400 MB. This is different from a real CST cartridge, which can hold more than 400 MB because of the effects of IDRC. Assuming an average IDRC ratio of 1:3, a real CST cartridge can hold up to 1.2 GB of data.

Applications that attempt to directly copy a real CST cartridge onto an emulated CST cartridge will fail if more than 400 MB are on the real cartridge and the application cannot handle the change to a multivolume file. DFSMSHsm is an example of such an application. A copy of an emulated CST cartridge to a real cartridge, however, will always fit.

7.19.1.3 ECCST = 800 MB

The emulated ECCST cartridge stores up to 800 MB. This is different from a real ECCST cartridge, which can hold more than 800 MB because of the effects of IDRC. Assuming an average IDRC ratio of 1:3, a real ECCST cartridge can hold up to 2.4 GB of data.

Applications that attempt to directly copy a real CST cartridge onto an emulated CST cartridge will fail if more than 400 MB are on the real cartridge. A copy of an emulated CST cartridge to a real cartridge, however, will always fit.

7.19.2 Physical Volume

The physical volumes used in a Virtual Tape Server subsystem to store logical volumes are 3590 cartridges which provide a capacity of 10 GB if the data is not compressed. Because of a compression algorithm that is improved over the IDRC function of IBM 3490E devices, an IBM 3590 cartridge can store over 30 GB data.

The compression takes place in the IBM 3590 tape drive at the time the data is copied from the Tape Volume Cache to 3590 cartridges.

Assuming a compression ratio of 3:1, a single 3590 cartridge can physically store up to 75 emulated CST cartridges or up to 37 emulated ECCST cartridges, although the application cannot handle the change to a multivolume file. DFSMSHsm is an example of such an application.

7.19.3 Virtual Volume Advantages

A virtual volume is physically stored on DASD and therefore has some advantages over traditional tape processing.

7.19.3.1 Mount response time

The mount response time for a scratch mount request is a fraction of the time required on a physical volume because it is not dependent on the physical movement of a cartridge or the loading and threading delays of a physical tape.

The mount response time for a specific mount request, where the volume is in the tape volume cache, is a fraction of the time required on a physical volume because of the same reasons as above.

7.19.3.2 Fast tape motion commands

Tape positioning command such as Locate, Space or Rewind, for example, are performed in a fraction of the time required for a physical volume.

A Rewind/Unload command is performed in a fraction of time because it is not dependent on the delays of tape movement on a physical tape device.

7.19.3.3 Random access

You can randomly access tape data through the use of the available tape commands Read Block ID and Locate Block ID

7.19.3.4 Cache Volume reaccess

In many cases, data that is written to a tape volume from one job or job step is read by a subsequent job or job step. The time between creation and reaccess is variable. However, very often the reaccess occurs within the next few hours.

The tape volume cache is large enough to hold virtual volumes for several hours after they have been copied to stacked 3590 cartridges. The duration of this period is dependent upon the tape volume cache size and amount of data written by the host per hour.

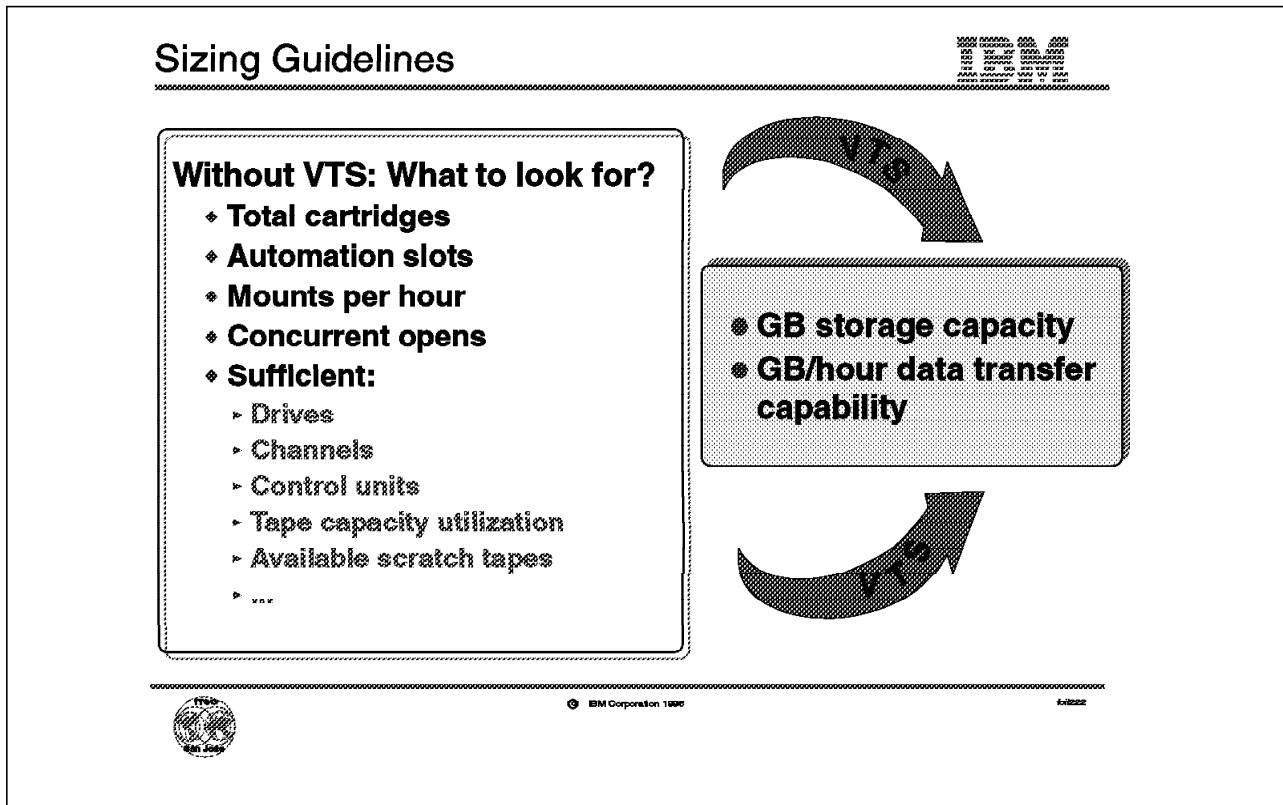

Figure 88. Sizing Guidelines

7.20 Sizing Guidelines

Today, to size an automated tape library and the tape drives included in it, you need to consider the number of:

- Total cartridges
- Automation slots
- Mounts per hour
- Concurrent opens
- Sufficient drives
- Sufficient channels
- Sufficient control units
- Sufficient tape capacity utilization
- Sufficient available scratch tapes

With the Virtual Tape Server, you need only to consider:

- How many gigabytes of tape data do I need to store?

For a single Virtual Tape Server subsystem, you can define up to 50,000 virtual volumes. If you define these volumes as ECCST, you can store up to 40 terabytes of data in a single Virtual Tape Server subsystem.

To calculate the physical number of Magstar cartridges required to store this data, a conservative approach would be to assume

- Compression ratio of 2:1
- 50% of the physical cartridges contain active data

| This would allow an average of 10 GB per Magstar tape drive. Divide the
| required number of gigabytes of tape data by 10 to calculate the number of
| physical Magstar cartridges for your Virtual Tape Server.

- How much data will I need to transfer per hour?

| We assume that the Virtual Tape Server capability is a throughput of 10 MB/s
| for a Virtual Tape Server subsystem, which equals an hourly throughput of 36
| GB. Dividing your required hourly throughput by 36 will give you the number
| of Virtual Tape Server subsystems required for your environment.

Sizing a VTS Subsystem



● Required information

- Data set categories
 - ◆ Offsite / Interchange
 - ◆ DFSMSHsm
 - ◆ MIMO
 - ◆ Data Recall
- IDRC Ratio
- Throughput
 - ◆ HSM Migrate/Recall MB
 - ◆ Hourly throughput
 - ◆ Workload Growth
 - ◆ Tape Drives
 - ◆ ...

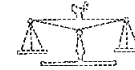

● Tools to support sizing

- ◆ VMA
- ◆ TDSA*
- ◆ DASD and Tape Magic for OS/2*
- ◆ QUIETIS*

IBM Marketing Tools



© IBM Corporation 1996

518220

Figure 89. Sizing a Virtual Tape Server

7.21 Sizing a Virtual Tape Server

To size a Virtual Tape Server subsystem, you need to evaluate your environment in term of:

- Data set categories

Categorizing your tape data is required to evaluate which data must be excluded from the Virtual Tape Server.

- IDRC Ratio

The IDRC ratio currently achieved helps you to define the number of physical Magstar cartridges required for your Virtual Tape Server subsystem

- Throughput

To define the number of tape drives inside an IBM 3494 Virtual Tape Server subsystem, to define the size of the tape volume cache, and to define the number of Virtual Tape Server subsystems, you need to know your throughput requirements.

The following tools are available to help you sizing your Virtual Tape Server subsystem in an MVS environment:

- Volume Mount Analyzer (VMA)

VMA is part of the DFSMSdfp component and can be used to analyze your tape environment.

VMA provides filtering capabilities that allow you to exclude tape data that you do not intend to store in the Virtual Tape Server and provides

information on the number of cartridges that are currently used, number of tape drives allocated in parallel, and gigabytes per hour written to tape.

- Quick and easy tape investigation and simulation (QUIETIS)

QUIETIS is an IBM internal analysis tool that provides information on your tape environment based on the information contained in the catalog of your tape management system on MVS. Currently, the following tape management systems are supported:

- DFSMSrmm
- EPIC/MVS
- TLMS
- CA-1

Please contact your technical IBM representative for further information.

- Tape Data Set Analysis (TDSA)

TDSA is an IBM internal tool specially developed for configuration of the IBM Magstar Virtual Tape Server (VTS). TDSA analyzes your tape environment based on VMA data and parameter input, and proposes the number of Virtual Tape Server subsystems, the IBM 3590 tape drives, and the library configuration of a Virtual Tape Server configuration that will meet your requirements today and in the future.

For analysis and for further information, please contact your technical IBM representative.

- DASD and Tape Magic for OS/2

DASD and Tape Magic for OS/2 make up a tool for IBM marketing use which helps in configuring IBM tape libraries. For details, please refer to your technical IBM representative.

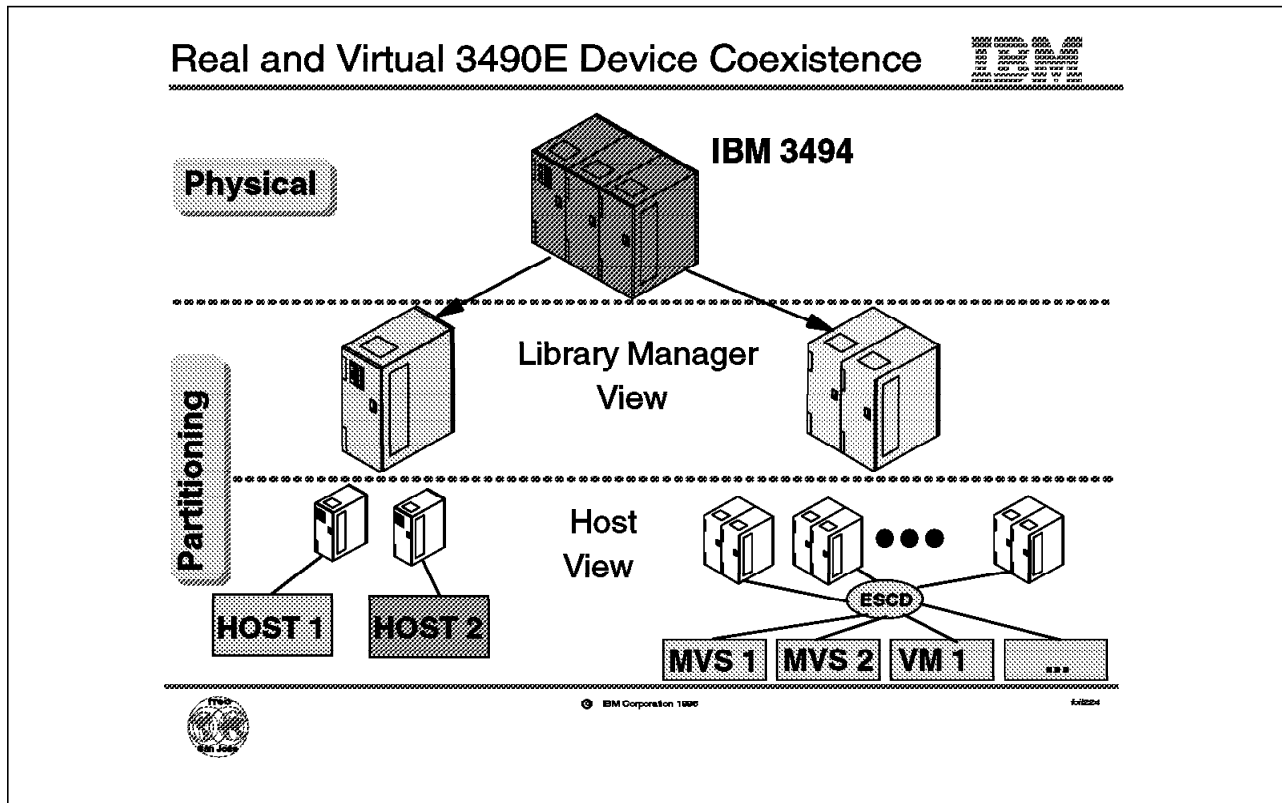

Figure 90. Real and Virtual 3490E Device Coexistence

7.22 Real and Virtual 3490E Device Coexistence

To support the coexistence of both real and virtual 3490E type devices in the same physical library, the library is logically partitioned.

Figure 90 shows the physical and logical implementation of an IBM Magstar Virtual Tape Server (VTS).

7.22.1 Physical Installation

A Virtual Tape Server subsystem must be installed in an IBM 3494 or 3495 tape library because the physical assets used by the Virtual Tape Server subsystem are managed by the Library Manager in the library. The physical assets include the Magstar tape drives and the Magstar cartridges used for stacking logical volumes.

7.22.2 Library Manager View

The Library Manager provides the support for logical partitioning of an IBM 3494 or 3495 tape library. To support the Virtual Tape Server's capability to coexist with current native IBM 3490, 3490E, and 3590 tape devices in the same library, the Library Manager partitions the physical library into logical libraries. This must be done because the Virtual Tape Server presents an image of 3490E tape devices, and yet cannot read or write a real CST or ECCST type cartridge. By placing a Virtual Tape Server subsystem in its own logical library, the possibility of host software allocating a virtual 3490E tape device for a real 3490 mount is removed. This also removes the possibility that host software could allocate a real 3490 mount instead of a virtual 3490E tape device.

A logical library can contain either a Virtual Tape Server subsystem, or current IBM 3490/3490E with or without native IBM 3590 tape subsystems. Given general availability of the IBM Magstar Virtual Tape Server (VTS), each physical IBM 3494 or 3495 tape library can be partitioned into two logical libraries:

- One contains one Virtual Tape Server subsystem
- The other contains all real IBM 3490 and all native IBM 3590 subsystems.

7.22.3 Host View

Each logical library has its own library sequence number used in defining the logical library to the host and therefore looks like a separate physical library to the hosts attached to that partition.

A single logical Virtual Tape Server library, can be shared by multiple MVS, VM, and VSE guest systems in the same way that a physical library can be shared.

For details on sharing or partitioning a logical library, please refer to the *Guide to Sharing and Partitioning IBM Tape Library Dataserver*.

Virtual Tape Server Installation Tasks

- **Physical installation and checkout**
- **Logical partitioning**
- **Teaching and inventory**
- **HCD required for library devices**
 - ◆ **Except BTLS**
- **Define the new library to the host**
- **Define volume serial (VOLSER) ranges**
 - ◆ **Logical volume**
 - ◆ **Physical volume**
- **Add Magstar cartridges**
- **Define fast-ready attribute**
- **Define inhibit reclamation schedule**

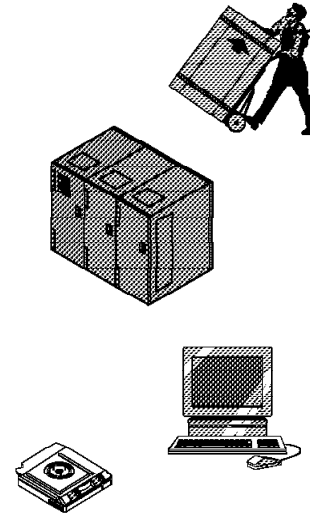

© IBM Corporation 1998

5/12/98

Figure 91. Virtual Tape Server Installation Tasks

7.23 Virtual Tape Server Installation Tasks

Figure 91 describes the tasks involved in installing an IBM Magstar Virtual Tape Server (VTS).

7.23.1 Physical Installation and Checkout

Hardware installation and checkout involves installing the hardware components of the Virtual Tape Server and performing the subsystem setup. At times during this phase, the library will either be unavailable to the host or degraded, because manual mode operation is required to satisfy host requests.

7.23.2 Logical Partitioning

Logical partitioning is performed by the hardware customer engineer as part of the physical installation of the Virtual Tape Server subsystem.

7.23.3 Teach and Inventory

Teaching the robotics the locations of the Magstar tape drives associated with the Virtual Tape Server and inventory of storage cells in the Virtual Tape Server frames is performed by the hardware customer engineer (CE) or customer service representative (CSR) as part of the Virtual Tape Server subsystem installation.

7.23.4 Hardware Configuration Definition (HCD) Required For Library Devices

Because the virtual tape drives of the Virtual Tape Server are library resident, you must define them through the hardware configuration definition dialogue specifying LIBRARY=YES. As for the VTS drives resident in the physical library, there is no definition in IOCP/MVSCP/HCPRIO.

For BTLS-managed libraries, HCD is not required, because BTLS does not require the LIBRARY=YES definition.

7.23.5 Define the New Library to the Host

For details on defining a new library to the host, please refer to Figure 92 on page 200.

7.23.6 Define Volume Serial Number Ranges

Although a physical library partitioned in the way described in Figure 90 on page 195 looks like two separate libraries to the host, they share the same library manager and its database. Because of this, the volume serial numbers of both the virtual and physical volumes in the same physical library must be unique.

Before you can insert physical 3590 cartridges for use by the Virtual Tape Server subsystem into a library, you must define them through the Library Manager console. You must also define a beginning set of volume serial ranges for your virtual volumes as well.

Volume serial numbers supported by the Virtual Tape Server must be six characters long and contain either an alphabetic or numeric character in any character position.

You add the volume serial number ranges through a Library Manager panel that contains two edit fields. If just one volume serial number is to be added, you enter the volume serial number in the first field and leave the second field empty. If a range of volume serial numbers is to be added, enter the two volume serial numbers that indicate the ends of the range in the two fields. You do not need to be concerned with which end to put in which field; the Library Manager will determine the range expansion regardless of whether the highest volume serial number is in field one or two.

Both volume serial numbers must have the same format. The same format means that if a character position in the first volume serial number is alphabetic, the corresponding character position in the second must be alphabetic as well. Likewise, if a character position in the first is numeric, the corresponding character position in the second one must also be numeric. For example, a range of ABC000 through ABD999 is valid, but ABC000 through ABCD99 is invalid.

To add multiple ranges, simply repeat the volume serial number entry process.

Volumes defined through the Library Manager console are processed as described below:

Logical

The Library Manager expands the specified volume serial number range, adds the resultant volumes to its inventory, places them in the

insert category and notifies all attached hosts. The hosts can then perform insert processing for these volumes as they would for physical cartridges in the library.

The range of volumes is expanded starting with the lower valued volume serial number (A is less than B, B is less than C, and so on). The volume serial number is incremented where alphabetic characters are incremented alphabetically and numeric characters are incremented numerically. For example, a volume serial number range specified as ABC000 and ABD999 would result in 2000 volumes being added (ABC000 - ABC999 and ABD000 - ABD999).

Physical If a 3590 cartridge is inserted into a library and fits into the volser range defined for physical volumes used by the Virtual Tape Server subsystem, the Library Manager does not notify any host. Management of these cartridges is under control of the Library Manager and the Virtual Tape Server subsystem. If you did not define the physical volumes for use by the Virtual Tape Server subsystem before entering them into the library, the Virtual Tape Server subsystem will not be able to use these cartridges.

You do not have to define all of the logical and physical ranges during installation. As needed, additional volume serial number ranges may be added later. You also do not have to have add all of the physical 3590 cartridges you defined at one time, they can be added as needed.

7.23.7 Add Magstar Cartridges

After you have defined the Magstar cartridges through the Library Manager console, you can insert them into the IBM 3494 or 3495 tape library.

7.23.8 Define Fast-Ready Categories

To take advantage of the scratch-mount performance advantages of the Virtual Tape Server, as described in Section 7.16, "Scratch Mount Scenario" on page 181, you need to indicate to the Library Manager the numbers of the categories used by the host for scratch volumes. You do this through the Library Manager console. The Library Manager provides a panel by which a 4-digit category number can entered. This will add the category to the list of categories in the library that have the Fast-Ready attribute set. To reset a category's Fast-Ready attribute, the Library Manager panel allows you to highlight one of the categories in the list with the Fast-Ready attribute set and then request that it be reset.

7.23.9 Define Reclamation Schedule

To minimize the effect of IBM Magstar Virtual Tape Server (VTS) internal space reclamation on your tape operation, you can inhibit space reclamation for certain periods of time through the Library Manager console.

Implementing the Virtual Tape Server

IBM 3590
Tape Subsystem
Technical Guide
Chapter 7
Implementing the
Virtual Tape Server
Page 19 of 20

• MVS Environments

• DFSMS System-Managed Tape (SMT)

- Define new storage group with VTS library
- Storage group cannot include VTS and non-VTS libraries
- ACS routines direct allocations to the VTS

• BTLS

- Define esoteric unit name for virtual tape devices
- Use the esoteric unit name to allocate virtual tapes in VTS

• VM Environments

- Define new library and drives
- Define logical volser range for insert processing

• VSE Guests

- Define LIBCONFIG LIST
- Define LIBRCMS XREF
- Update TMS



© IBM Corporation 1996

51820

Figure 92. Implementing the Virtual Tape Server

7.24 Implementing the Virtual Tape Server

From software point of view, the Virtual Tape Server is same as the IBM Automated Tape Library Dataserver with IBM 3490E tape drives. We explain how to implement the Virtual Tape server in MVS/ESA, VM/ESA, and VSE/ESA environments.

7.24.1 MVS/ESA Environments

In general, the Virtual Tape Server subsystem must be defined as a new tape library, with IBM 3490E tape drives as the host system.

7.24.1.1 DFSMS System-Managed Tape (SMT)

To use the Virtual Tape Server subsystem under SMT, you must define the virtual 3490E devices through HCD specifying LIBRARY=YES.

During hardware installation of the Virtual Tape Server, the customer engineer assigns a five-character library sequence number to the VTS library. You use this sequence number to define a new library to SMS through the ISMF Library application.

To direct allocations to the Virtual Tape Server subsystem, you must define new storage groups that only contain VTS libraries. You cannot intermix VTS and non-VTS libraries in the same storage group. However, if you have more than one VTS library installed, you can define storage groups that span more than one VTS library.

You must change your ACS routines to assign these newly defined storage groups. If the storage group ACS routine assigns a storage group that contains a VTS library, the tape data set is directed to the Virtual Tape Server subsystem.

For details on the implementation in an SMS managed environment, please refer to the *DFSMS/MVS Version 1 Release 3 Object Access Method Planning, Installation, and Administration Guide for Tape Libraries*. For further information on sharing a VTS library, please refer to the *Guide to Sharing and Partitioning IBM Tape Library Dataserver*.

7.24.1.2 Basic Tape Library Support (BTLS)

If you implement the Virtual Tape Server subsystem under BTLS, you can define the tape drives through the Hardware Configuration Definition (HCD) dialogue, or you can use IOCP and MVSCP.

You need to define a new logical library to BTLS that contains all virtual devices associated with this logical library. If only BTLS is using the Virtual Tape Server subsystem, you define all 32 drives.

To direct tape allocations to the Virtual Tape Server, you define a new esoteric unit name and use it in the DD statement for the newly allocated tape data set.

Because of the library definitions, BTLS knows that the device allocated resides in a Virtual Tape Server library.

For BTLS implementation details, please refer to the *Basic Tape Library Support Version 1 Release 1 User's Guide and Reference*.

7.24.2 VM/ESA Environments

After you have defined the new library through HCD, you must define it to DFSMS/VM, if the VM system will directly use the Virtual Tape Server subsystem.

You define the VTS library through the DFSMS/VM DGTVCNTL DATA control file. You define the tape drives that are available through the RMCONFIG DATA configuration file.

To allow the removable media services (RMS) component of DFSMS/VM to perform automatic-insert bulk processing, you must create the RMBnnnnn DATA file in the VMSYS:DFSMS.CONTROL directory. The nnnnn matches up with the five-character library sequence number that is assigned to the Virtual Tape Server during hardware installation.

For details on the implementation of DFSMS/VM and RMS, please refer to the *VM/ESA DFSMS/VM Function Level 221 Removable Media Services User's Guide and Reference*. If the Virtual Tape Server subsystem is shared among your VM system and other systems, additional considerations apply. Please refer to the *Guide to Sharing and Partitioning IBM Tape Library Dataserver* for further information.

7.24.3 VSE/ESA Guests

VSE/ESA must run as a guest system under VM/ESA to use a VTS library. The VSE Guest Server (VGS) support must be installed as well as DFSMS/VM RMS for communication with the Library Manager of the VTS library.

You must define the LIBCONFIG file on the VGS service machine's A-disk. This file simply cross-references the VSE/ESA guest's library names with the names that DFSMS/VM uses.

To enable VSE/ESA guest exploitation of inventory support functions through the LIBSERV-VGS interface, the LIBRCMS part must be installed on the VM system. If VGS is to service inventory requests for multiple VSE/ESA guests, you must edit the LIBRCMS SRV NAMES cross-reference file. This file enables the inventory support server to access Librarian files on the correct VSE guest machine.

For further information, please refer to the *Guide to Sharing and Partitioning IBM Tape Library Dataserver*.

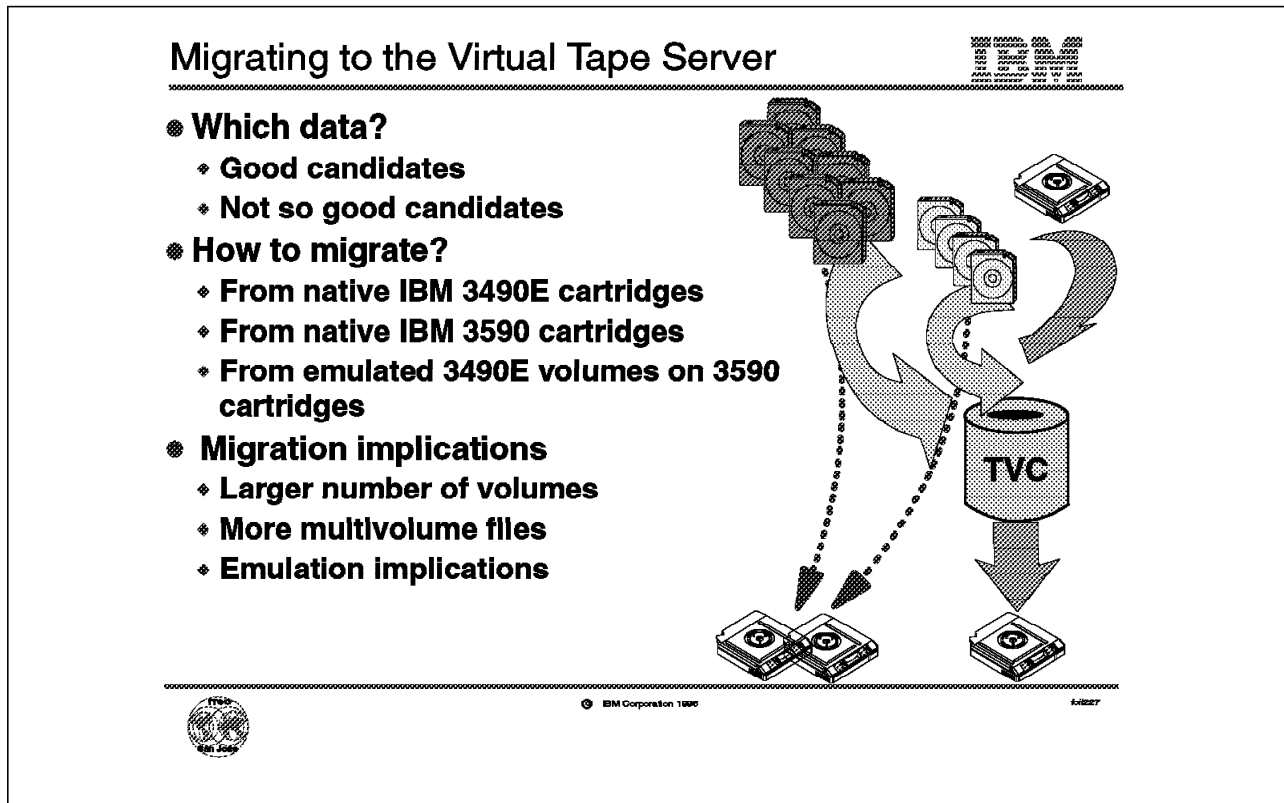

Figure 93. Migration to the IBM Magstar Virtual Tape Server (VTS)

7.25 Migration to the IBM Magstar Virtual Tape Server (VTS)

Although migrating to a Virtual Tape Server subsystem is transparent to the host, there are some considerations to be made because you are migrating from physical to logical volumes Figure 93. This is mainly because the physical and the logical volumes are of different size, owing to the fact that the Virtual Tape Server does not use hardware compaction.

7.25.1 Which Data?

In general, all tape data can be under control of a Virtual Tape Server subsystem. Especially if your tape processing is currently restricted by the number of tape drives, you may want to direct as much as possible to the Virtual Tape Server, utilizing the full 32 virtual tape drives.

Before migrating, you should however review the exceptions that you may want to leave on native tape cartridges. Exceptions could be:

- Data that must be removed from the Virtual Tape Server library.
Data in this category is usually interchange data or data that must be stored for some period of time in a remote vault. Such data should initially be directed to native tape or it must be copied from the Virtual Tape Server library to native tape.

- Data whose retrieval time from tape would increase too much.
Some data retrieval applications, involving extraction of just part of data residing on a volume, as for example for a DFSMSHsm recall, may

experience longer retrieval times if the volume is stacked and doesn't reside in the tape volume cache.

- Tape jobs whose nature makes native tape more cost effective.

Tape applications that already utilize both high tape bandwidth and capacity may be more effective if kept on native volumes. Such applications are not common, and are generally restricted to certain types of efforts, such as seismic data processing.

7.25.2 How to Migrate?

Migrating your tape data into a Virtual Tape Server subsystem can be done in two ways:

1. Copy your tape data.
2. Direct new allocations to the Virtual Tape Server and let the data outside the Virtual Tape Server expire.

The approach is the same no matter on which type of cartridge the tape data was stored before.

7.25.3 Migration from Physical IBM 3490E

There are some implications if you are migrating from native 3490E volumes to emulated 3490E volumes. Because the Virtual Tape Server subsystem does not have hardware compression, an emulated 3490E cartridge will either store 400 MB or 800 MB of tape data. If you are currently utilizing the full capacity of a CST or ECCST type cartridge, migrating to emulated 3490E will result in more multivolume files and thus in a larger number of volumes to be managed by your tape management system and the system catalog.

Reading data for a large data set could result in more tape mounts than before. Since some large data sets that once occupied just one physical volume will now occupy two or more logical volumes, there is a potential for more tape mounts to recall all of the logical volumes. However, extra tape mounts will not occur if the stacked cartridge is still in the drive when subsequent logical volumes are referenced. Please note that spreading the data over several logical volumes will not increase the number of physical scratch mounts. Analyses so far have shown that the increase in mounts resulting from multiple logical mounts is more than compensated for by the decrease in mounts due to scratch and read cache hits.

Data copied out of a Virtual Tape Server subsystem can occupy more native tapes than if the data were written initially on native drives. The DFSMSHsm TAPECOPY command, for example, may increase the number of cartridges that have to be trucked to offsite vaults or sent back to users.

There are some differences between the Virtual Tape Server subsystem's emulation of a 3490E device, and a real 3490E device, in addition to those described for the size of the logical and physical volumes. The differences are:

- Dynamic Device Reconfiguration (DDR)

DDR is an error recovery operation that is performed by the host to retry a failed operation on another physical tape device when an unrecoverable error has occurred. With virtual drives, there are no unrecoverable errors that could be resolved by swapping to a different drive. Therefore, error

codes that would indicate DDR are not reported; instead, ERA 35, Drive Equipment Check is reported.

- Read Buffer command

The Read Buffer command always returns zero bytes of data.

- Erase Gap command

The execution of the Erase Gap command does not cause an actual gap on the virtual device.

- Data Security Erase Command

The execution of the Data Security Erase command does not cause random data patterns to be written on a virtual volume to its virtual end-of-tape. Instead, the End-of-Data (EOD) mark is repositioned at the logical block location at which the command was issued. Any data beyond that logical block location is no longer accessible.

When the virtual volume is copied to a Magstar cartridge, only the data up to the EOD mark is written. Any data beyond this point is no longer accessible by the host.

- Reading or Positioning beyond EOD

The boundaries of a virtual volume are limited by the BOT and EOD mark location. Any attempt to read or position beyond the EOD mark fails, indicating ERA 36, End-of-Data.

- Load Display Command

The execution of the Load Display command is accepted and returns with an error-free ending status, but the information contained in the command is discarded.

- Block IDs

The format of the 4-byte field of a block ID is identical to that for a real 3490E device, except that the tape direction, segment, and format mode information contained in Bits 0-9 is set to B'0'.

The Virtual Tape Server subsystem maintains two block IDs for each virtual tape device:

Channel Block ID The channel block ID maintains the current tape position from the host program's perspective and reflects the tape positioning resulting from the last tape motion command issued by the host. The block ID identifies the next logical block to be accessed in the forward direction.

Device Block ID When performing write operations, the device block ID identifies the last logical block that was implicitly or explicitly synchronized to the physical DASD of the tape volume cache. For read operations, the device block ID is the same as the channel block ID.

- The subsystem always reports that it is achieving a 1:1 compaction ratio.

Monitoring the IBM Magstar VTS

```

0000 000000 000 000
00 00 00 0000 0000
00 00 0000 0000000
00 00 00 00 00 00
0000 00000 000 000
0000 00000 000 000
    
```

◆ Event Logging

- ◆ Accumulated and written to a virtual volume once a day
- ◆ Accessible by the host
- ◆ Three types of log records
 - Control Unit Initialization
 - Virtual Volume Event
 - Library Manager Hourly Statistics

◆ Library Reporting

- ◆ Operational statistics for a Virtual Tape Server
- ◆ SMF Record Type 94
 - Virtual mount statistics
 - VTS operational information
 - Physical library statistics
- ◆ Library Manager
 - Library statistics

Virtual Volume Events

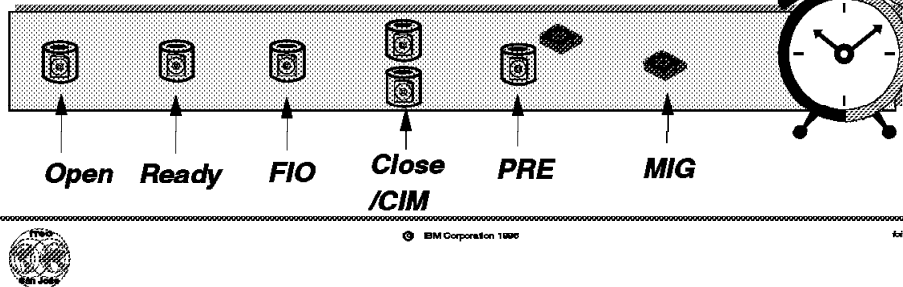

Figure 94. Monitoring the IBM Magstar Virtual Tape Server

7.26 Monitoring the IBM Magstar Virtual Tape Server (VTS)

Figure 94 shows the monitoring provided by the Virtual Tape Server. Once a Virtual Tape Server has been installed and is operational, the focus of a customer's management shifts from "What kind of work will we have it do?" to "How is it doing?" The Virtual Tape Server, working with the Library Manager, provides ongoing management information to answer that question. Information about the performance and operational usage of the Virtual Tape Server is provided in both detailed and summary form and is host accessible. In addition, graphical displays of some of the key operational and performance aspects of the Virtual Tape Server are displayable through the Library Manager console.

The Virtual Tape Server/Library Manager provides:

- Virtual Tape Server event logging
- Operational Statistics for the virtual and physical aspects of the tape library
- Operational and Performance display graphs through the Library Manager console

7.26.1 Event Logging

Several kinds of events that occur in the Virtual Tape Server are logged. Most of the events provide detailed information about the actions taken against the virtual volumes in the server. Other events include when the Virtual Tape Server controller was initialized and an hourly summary of operational and performance statistics for the library. All log events are date- and time-stamped to a resolution of 1/100 of a second.

Log events are accumulated daily and then written out to a virtual volume in the system at midnight. A special set of volumes, one for each day of a year, are used for this purpose, providing a one-year rolling log of events. Once a day's log of events has been written to a virtual volume, that log is available for host access.

The log data for a day is contained in a single file on the volume. The size of the log file depends on the number of virtual volumes processed during the day. Nominally, the number of bytes logged for each virtual volume is between 200 and 300. If the library processes 5,000 virtual volumes in a day, that would result in a log file size of approximately 1.5 MB.

The types of log events are described in subsequent sections.

7.26.1.1 Control unit initialization

The log events provide detailed information about the use of each virtual volume by the Virtual Tape Server. Please see Figure 94 on page 206, which contains a time stamp, the event, and the library sequence number of the logical library that contains the Virtual Tape Server subsystem.

7.26.1.2 Virtual volume event

For a virtual volume, the following events are logged:

- The beginning of a mount operation for a virtual volume.
This event is indicated in the figure by Open
- The completion of a mount operation.
This event is logged when the virtual device is ready and is indicated by Ready. This log record also includes the size of the volume.
- The issuance of the first Read, Write, or Tape Motion command to the virtual device after a mount is completed.
This event is indicated in the figure by FIO.
- The completion of rewinding and unloading of a virtual volume.
This event is indicated in the figure by Close. The log record also includes the size of the volume, whether it was modified, and the number of bytes read or written from or to the volume by the host.
If a virtual volume was modified while it was open and is scheduled for premigration. This event is indicated in the figure by CIM.
- If the virtual volume was modified it will be premigrated.
This event is indicated in the figure by PRE.
- The removal of a virtual volume from the tape volume cache.
This event is indicated in the figure by MIG.

7.26.1.3 Library Manager hourly statistics

A group of records are written to the log that contain the data the library manager generated about the last hour's performance of the library. There are nine records in the group which contain the same information as is provided in SMF Record Type 94. This group of records is written to the log at the same time it is being provided to the attached hosts. Refer to Section 7.26.2, "Library Reporting" for the content of the records.

7.26.2 Library Reporting

SMF Record Type 94 will include the virtual mount statistics and VTS operational information when the record is written for a logical library that contains a Virtual Tape Server subsystem. The information listed below will be provided:

- Number of currently installed and available physical drives.
- Maximum, minimum, and average number of physical drives that were mounted in parallel during the last hour.
- Maximum, minimum, and average physical mount time during the last hour.
- Number of physical mounts completed during the last hour for:
 - Recalls
 - Migrate
 - Reclaim
- Number of currently configured virtual drives.
- Maximum, minimum, and average number of virtual drives that were mounted in last hour.
- Maximum, minimum, and average virtual mount time during the last hour.
 - Number of virtual mounts completed during the last hour for:
 - Fast-Ready
 - Specific tape volume cache
 - Recalls
 - Number of virtual volumes premigrated during the last hour.
 - Number of bytes written to and read from the VTS during the last hour.
- Number of bytes written and read from a stacked 3590 cartridges in the last hour.
- Average tape volume cache age at the end of the reported hour.
- Average volume size in the tape volume cache at the end of the reported hour.
- Number of virtual volumes in the tape volume cache at the end of the reported hour.
- Number of bytes of active data managed by the Virtual Tape Server determined as of the end of the previous day.
- Number of bytes of free space available in the VTS as of the end of the previous day.

7.26.3 Library Manager Displayed Information

Through the Library Manager console, several of the key operational and performance statistics regarding a Virtual Tape Server are displayed in a graphical format. These are in addition to the current performance graph. The information displayed includes:

- A 30 day graph showing the daily state of the storage space managed by the Virtual Tape Server. The graph displays four values:
 - Total effective managed storage capacity of the Virtual Tape Server.
 - Number of gigabytes of active data

- Number of gigabytes of free space
- Free-space alert threshold.
- A 24-hour graph showing the data throughput in gigabytes per hour of the Virtual Tape Server. The graph displays four values:
 - Host read gigabytes
 - Host write gigabytes
 - 3590 device read gigabytes
 - 3590 device write gigabytes
- A 24-hour graph showing how virtual mounts were performed during each hour. The graph displays three values:
 - Number of mounts completed with Fast-Ready (scratch mounts).
 - Number of mounts completed because the needed volume was in the Tape Volume Cache.
 - Number of mounts completed by recalling data from a stacked cartridge.
- A 24-hour graph of the hourly usage of the 3590 devices managed by the Virtual Tape Server. The graph displays three values:
 - Maximum physical devices concurrently mounted
 - Minimum physical devices concurrently mounted
 - Average physical devices concurrently mounted.
- A 24-hour graph of the virtual mounts completed each hour.

Operating the Virtual Tape Server

0000 000000 000 000
0000 000000 000 000
00 00 00 0000 0000
00 00000 00000000
00 000000 00000000
00 00 00 00000000
0000 000000 000 000
0000 000000 000 000

- **Library Manager Updates**
 - ◆ **Define logical volumes**
 - ◆ **Define physical volumes**
 - ◆ **Insert cartridges to VTS**
 - ◆ **Inhibit space reclamation**
- **Vaulting**
 - ◆ **Electronically only**
 - ◆ **No physical cartridge movement**
 - ◆ **Removing volumes from the IBM 3494 or IBM 3495 library**
- **Error Recovery**



© IBM Corporation 1990

5/12/90

Figure 95. Operating the IBM Magstar Virtual Tape Server (VTS)

7.27 Operating the IBM Magstar Virtual Tape Server (VTS)

Figure 95 lists the steps in operating the Virtual Tape Server.

7.27.1 Library Manager Updates

Updating entails defining the volumes, inserting the cartridges, and dealing with the space occupied by the old data. The Library Manager provides an interface for defining logical and physical volumes and to inhibit space reclamation.

7.27.2 Vaulting

Vaulting is preserving data in a reliable way. Data can be moved from the Virtual Tape Server subsystem only by copying it to a physical tape. Any attempt to eject a logical volume will result in an error message and the eject command will be rejected.

Note: Do not remove any Magstar cartridge from a library containing a Virtual Tape Server subsystem by just opening the door and taking the cartridge out. Always use the host command to eject a cartridge from the library. This will ensure that Magstar cartridges owned by the Virtual Tape Server are not removed inadvertently.

7.27.3 Error Recovery

If the IBM Magstar Virtual Tape Server (VTS) detects either a write or read error on a 3590 cartridge and the error is not recoverable (the recovery process includes retrying the read or write on another 3590 device), the following occurs:

- The valid active data from the physical volume is moved to another physical volume.
- The physical volume is ejected to the convenience output station.
- A message is sent to each attached host indicating that an intervention is required in the library.
- The operator intervention panel on the Library Manager indicates that volume xxxxxx has a permanent data error and has been ejected.

The database information stored by the Library Manager and the Virtual Tape Server subsystem is critical to the operation of a Virtual Tape Server subsystem. The database contains the location of the physical resources in the library (devices, cartridge) as well as information on the logical volumes and their associated stacked volume locations.

The Virtual Tape Server subsystem provides facilities to allow for the recovery of the database information in the case of a major failure or disaster. Your involvement is not required to ensure that critical information is being protected, but your involvement can be required to perform some of the steps of a recovery operation.

In the worst case that all database information is lost, the database can be recreated from the information in the stacked volumes.

Chapter 8. IBM Magstar 3590 Silo-Compatible Tape Subsystem

This chapter describes how the IBM 3590 Magstar Tape Drive can be installed in a StorageTek Automated Cartridge System.

STK Trademarks

0000 000000 000 0000
000 000 000 0000 0000
00 00 00 0000 0000
00 00000 00000000
00 000000 00000000
00 00 00 000000
0000000000 000 0000
0000000000 000 0000

● **The following are trademarks (*) of, or terms used by, Storage Technology Corporation:**

- ◆ **4410 Automated Cartridge System**
- ◆ **NEARLINE Library System**
- ◆ **4480 Cartridge Tape Subsystem**
- ◆ **9310 PowderHorn* Automated Cartridge System**
- ◆ **Host Software Component (HSC)**
- ◆ **Library Control Unit (LCU)**
- ◆ **Library Management Unit (LMU)**
- ◆ **Library Storage Module (LSM)**
- ◆ **RedWood* SD-3 Helical Cartridge Tape Subsystem**
- ◆ **Silo**
- ◆ **Silverton 4490 Cartridge Subsystem**
- ◆ **StorageTek***
- ◆ **TimberLine* 9490 Cartridge Tape Subsystem**



© IBM Corporation 1996

Figure 96. STK Trademarks

8.1 STK Trademarks

The StorageTek Automated Cartridge System has been on the market for some years and some of the components are trademarks of the Storage Technology Corporation, marked with an asterisk (*) in Figure 96. Other parts of the system are represented by terms or definitions that are used by STK or installations having a Silo installed:

- **4410 Automated Cartridge System**

This is the first Silo, also called Nearline, introduced by StorageTek in 1987.

- **4480 Cartridge Tape Subsystem**

This is the StorageTek IBM 3480-compatible tape subsystem, using 18-track format standard cartridges and is able to attach to parallel channels only.

- **9310 PowderHorn Automated Cartridge System**

This is the second version of the Silo introduced by StorageTek in 1993 and has approximately twice the robotics performance of the StorageTek 4410 Automatic Cartridge System.

- **Host Software Component (HSC)**

The primary function of HSC is to steer allocation, mounting, and dismounting of different cartridge types. The HSC basically intercepts console messages before they are visible to the operator.

- **Library Control Unit (LCU)**

Receives and responds to requests from the hosts and directs the function to the robotics of the Library Storage Module (LSM).

- **Library Management Unit (LMU)**

Provides an interface between the Host Software Component (HSC), and the Library Control Units (LCUs), attached to each Library Storage Module (LSM).

- **Library Storage Module (LSM)**

The LSM is a free-standing robotic arm within a twelve-sided cylindrical housing (the Silo), with storage capacity for approximately 6000 cartridges.

- **RedWood SD-3 Helical Cartridge Tape Subsystem**

This is the latest tape drive announced from StorageTek; it uses helical-scan technology. Because helicalscan is a very expensive technology to use and maintain, this type of device should only be used for very special niche applications.

- **Silo**

Some people use this term as the name of the whole subsystem and some use it as the name of the LSM. Nicknames for the Silo exist in different local languages.

- **Silverton 4490 Cartridge Subsystem**

This is the StorageTek IBM 3490E-compatible tape subsystem, using 36-track format standard cartridges and is able to attach to parallel channels only.

- **StorageTek**

StorageTek or STK are short versions of the company name of Storage Technology Corporation.

- **TimberLine 9490 Cartridge Tape Subsystem**

This is the StorageTek IBM 3490E-compatible tape subsystem, using 36-track format extended cartridges and with a performance twice that of the Silverton 4490 Cartridge Subsystem.

See Section 8.3, "Configuration Overview" on page 218 for an overview of a StorageTek Automated Cartridge System with IBM Magstar tape drives.

Why Use IBM 3590 Magstar in an STK Silo?

0000 000000 000 0000
0000 000000 000 0000
00 00 00 00 0000 0000
00 000000 00000000
000 000000 00000000
00 00 00 00 00 00 00
0000 000000 000 0000
0000 000000 000 0000

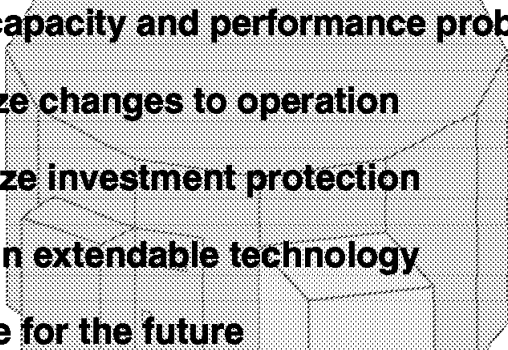
- 
- **Solve capacity and performance problems**
 - **Minimize changes to operation**
 - **Maximize investment protection**
 - **Invest in extendable technology**
 - **Prepare for the future**



© IBM Corporation 1996

KENGVHYY

Figure 97. Why Use IBM 3590 in an STK Silo?

8.2 Why Use IBM 3590 Magstar in an STK Silo?

- ***Solve capacity and performance problems.***

The capacity in terabytes of a StorageTek Silo can be increased by up to 50 times by attaching IBM 3590-C12 frames. Comparing on the basis of the uncompacted storage capacity of a cartridge and recording technology, the IBM Magstar cartridge can store 50 times as much as IBM 3480 drive technologies and 12 times as much as IBM 3490E drive technologies using an Enhanced Capacity cartridge.

The performance of the IBM Magstar tape drives may substantially improve throughput for certain tape applications. They will also have the performance to improve dump and restore times for the newly announced RAMAC-3 array disk.

- ***Minimize changes to operation.***

When installing an IBM 3590-C12 frame, no new software is required because existing 3490E tape applications also run on IBM 3590-C12. If the esoteric unit names used by existing applications are defined for the new drives, no JCL-changes are required.

- ***Maximize investment protection.***

By adding an IBM 3590-C12 frame, or installing it to replace existing tape drives, the investment in all other parts of the StorageTek Automated Cartridge System is retained at the same time as the capacity and the performance are improved.

Later, the IBM Magstar 3590 cartridges and the IBM 3590-B1A drives can be moved and installed in an IBM Automated Tape Server, such as the IBM 3494, giving you the option to use virtual tapes and drives to maximize the utilization of your investment.

- ***Invest in extendable technology.***

In 1995, IBM first announced the IBM Magstar 3590 tape subsystem and now in 1996 substantial additions have been announced in products, functions, and features. The IBM Magstar technology will be further enhanced and new products, functions, and features will be included in future announcements. By installing the IBM 3590-C12 in the StorageTek Silo, you will invest in a technology that will be extended in the future.

- ***Prepare for the future.***

As you have seen in earlier chapters of this book some functions and features of the IBM Magstar technology will be available next year and even more are expected in the future. By installing the IBM 3590-C12 now, you prepare to take full advantage of all functions and features of the IBM Magstar technology. Also by installing the IBM 3590-C12 now, you reduce the number of cartridges, and convert all your tape data to the new technology.

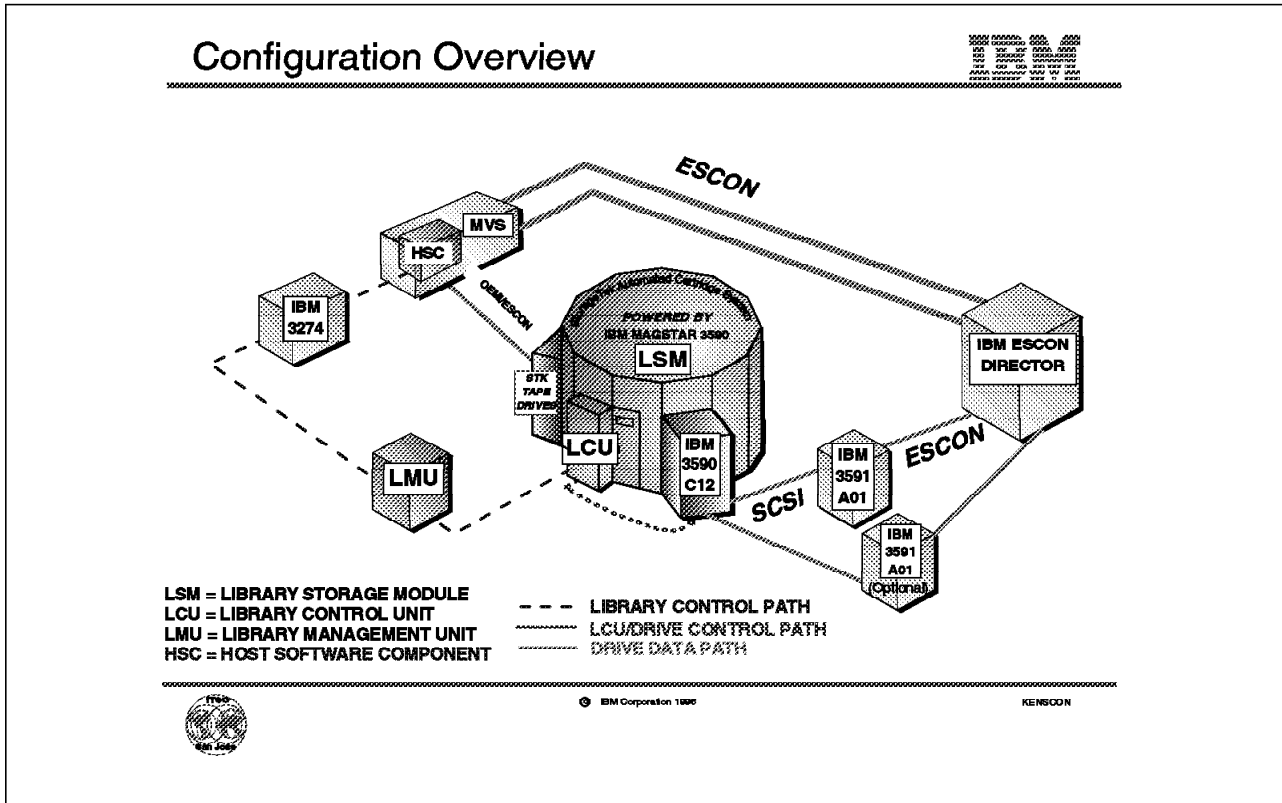

Figure 98. Configuration Overview

8.3 Configuration Overview

The components of a StorageTek Automated Cartridge System with an IBM 3590 Model C12 Silo-Compatible Frame installed (Figure 98) are as follows:

- **Library Storage Module (LSM)**
 - Contains the Magstar 3590 Data Cartridges, Magstar 3590 Cleaning Cartridges, and Magstar 3590 Diagnostic Cartridges, and cartridges for STK drives, if installed, as well as storage slots and robotics.
 - Up to sixteen drives can be attached to one LSM.
- **Library Control Unit (LCU)**
 - Controls the robotics motion and interfaces to the drives through the LCU/DRIVE Control Path. The LCU gets orders from the Library Management Unit, see below, through the Library Control Path.
- **IBM 3590-C12 (Silo-Compatible Frame)**
 - Contains four IBM 3590-B1A drives attached to StorageTek LSM and interfaces with the StorageTek LCU through the LCU/DRIVE Control Path. More information on the IBM 3590-C12 will follow in Section 8.4, "IBM 3590 Model C12" on page 220.
- **StorageTek Tape Drives**
 - These may be installed at the same time as the IBM 3590-C12.

- **IBM 3591-A01 (ESCON Tape Controller)**

IBM 3591-A01 ESCON tape controller provides for ESCON attachment of the IBM 3590-B1A drives as if they are IBM 3490E drives. More information on the IBM 3591-A01 will follow in Section 8.4, "IBM 3590 Model C12" on page 220.

- **IBM ESCON Director**

The ESCON director allows the drives in the IBM 3590-C12 to be accessed from multiple hosts or logical partitions. This is optional.

- **Library Management Unit (LMU)**

The LMU converts the mount commands from up to 16 hosts to robotic commands for up to 16 LCUs. The LMU interfaces with the LCUs and with the hosts (via a Network Controller, see below) through the Library Control Path.

- **Network Controller (for example, IBM 3274)**

The controller allows the Host Software Component, see below, to access the LMU through the Library Control Path.

- **Host Software Component (HSC)**

The HSC manages the cartridge-to-slot database and steers drive allocation.

IBM provides maintenance for the entire library subsystem and problem determination assistance for interoperability issues in split maintenance environments.

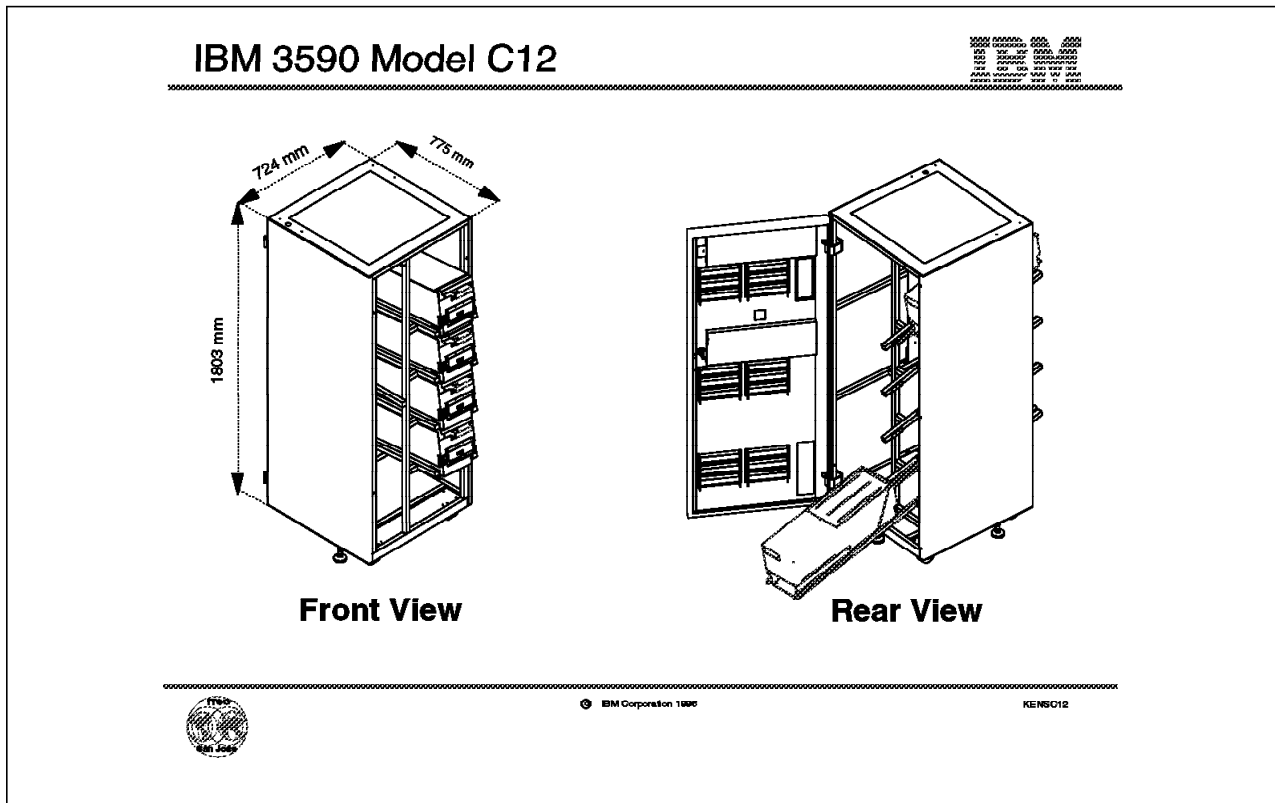

Figure 99. IBM 3590 Model C12

8.4 IBM 3590 Model C12

The IBM 3590-C12 Silo-Compatible Frame (Figure 99) is designed for attachment to a StorageTek Automated Cartridge System, often called a Silo. Four IBM 3590-B1A drives are installed in the IBM 3590-C12 frame. The SCSI bus of the IBM 3590-C12 attaches to an IBM 3591-A01 ESCON controller for 3490E emulation to the host. More information on the IBM 3591-A01 ESCON controller follows in Section 8.5, "IBM 3591 Model A01" on page 224.

The drives installed in the IBM 3590-C12 frame are standard IBM 3590-B1A drives with Feature 2003 which adds a target for the STK robotics and attachment for the drive display. The drives can later be installed in another configuration, such as the IBM 3494 Virtual Tape Server (see Section 8.10, "Migration Path to IBM 3494" on page 238).

The IBM 3590-B1A drives are oriented in the IBM 3590-C12 frame on slanted (15 degrees) trays, as shown in the front view in Figure 99. This is done so that the StorageTek robotic assembly can pick cartridges from and place cartridges in the IBM 3590-B1A loader mechanism. The IBM 3590 drive is designed for rear slide-out service in the IBM 3590-C12 frame (see rear view in Figure 99).

Table 11 on page 221 shows the physical specifications of the IBM 3590-C12 frame.

Four tape cartridges for diagnostics and a cleaning cartridge are supplied with each IBM 3590-C12. A three-month supply of data cartridges is recommended, along with cartridge labels to identify each cartridge's volume serial number.

See Table 12 on page 222 for ordering data cartridges with the IBM 3590-C12 Frame. For detailed information on ordering additional cartridges, see:

- *IBM 3590 Magstar High Performance Tape Subsystem Silo-Compatible Frame Model C12 Introduction, Planning, and User's Guide.*

Up to four IBM 3590-C12 units can attach to one LSM, allowing up to 16 IBM 3590-B1A drives.

Feature	Specification
Height	1803 mm (71 in.)
Width	724 mm (28.5 in.)
Depth (Free-Standing)	975 mm (38.4 in.)
Depth (Installed)	775 mm (30.5 in.) ¹
Weight	400 kg (880 lb) ²
Notes:	
1. In the service position, the maximum installed depth for Model C12 is 1635 mm (62.1 in.).	
2. This is the weight of a fullyloaded C12 frame.	

For more information on environmental specifications and additional information about the IBM 3590 Model C12, see:

- *IBM 3590 Magstar High Performance Tape Subsystem Silo-Compatible Frame Model C12 Introduction, Planning, and User's Guide.*

For additional information about the IBM 3590 Magstar tape drive, see:

- *IBM 3590 High Performance Tape Subsystem Introduction and Planning Guide*
- *IBM 3590 High Performance Tape Subsystem User's Guide,*
- *IBM 3590 High Performance Tape Subsystem Hardware Reference*
- *Magstar and IBM 3590 High Performance Tape Subsystem: Multiplatform Implementation*

An optional display mounted on the top of the IBM 3494-C12 (not shown in Figure 99 on page 220) is available from Texas Digital Systems, Inc. (TDS) of College Station, Texas 77845, USA, telephone (409) 693-9378. The TDS display features an 11-color LED display that can be read from a distance up to 27 meters, and provides drive status information. The display attaches to the RS-422 interface of each IBM 3590-B1A drive through a display controller mounted in the IBM 3494-C12 frame.

8.4.1 IBM 3590-C12 Features

Table 12 shows the feature codes for the features applicable to the IBM 3590-C12 frame.

Description	Feature Code
One 12 m (39.4 ft) SCSI cable; One SCSI bus with four drives	5201
Two 12 m (39.4 ft) SCSI cables; Two SCSI buses with two drives each	5202
One cleaning cartridge	8002
Seven 30-packs of tape cartridges (210 cartridges); without seventh character on VOLSER label	8210
Fourteen 30-packs of tape cartridges (420 cartridges); without seventh character on VOLSER label	8220
No data cartridges	9590
Chicago line cord, 2 meters	9986

- **Feature 520x**

You must select either Feature 5201 or 5202. Installation is performed at the plant. The 12-m cable is shipped separately from the drive and is installed in the field. Approximately 10 m of the 12-m SCSI cable length is available for connection to the IBM 3591-A01 ESCON controller.

Feature 5201 supplies one 12-m SCSI cable for attachment of a IBM 3590-B1A drive to a IBM 3591-A01 ESCON controller, and three 4-m SCSI cables for daisy-chaining to three additional IBM 3590-B1A drives in an IBM 3590-C12 frame. The SCSI cables are daisy-chained from the lowest drive in the frame to the top drive (see Figure 100 on page 224). A terminator is attached to the last connector in the top drive. The uppermost drive in the frame has SCSI address 0 and the bottom drive has SCSI address 3.

Feature 5202 supplies two 12-m SCSI cables for attachment of two IBM 3590-B1A drives each to two IBM 3591-A01 ESCON controllers, and two 4-m SCSI cables, each of which is used to daisy-chain the two drives connected to the IBM 3591 controllers. This results in two IBM 3590-drives on each bus (Figure 100 on page 224).

- **Feature 8002**

This feature supplies one cleaning cartridge. Up to ten Features 8002 can be specified for plant or field install.

- **Feature 8210**

You can order no more than one Feature 8210 containing 210 IBM 3590 Data Cartridges without the “seventh character” J on the external label.

- **Feature 8220**

You can order no more than Feature 8220 containing 420 IBM 3590 Data Cartridges without the “seventh character” J on the external label.

Features 8210 and 8220 are plant install only.

- **Feature 9590**

This feature should be specified if no data cartridges should be delivered with the IBM 3590-C12 frame.

Note: One of Features 8210, 8220, or 9590 must be ordered with every IBM 3590-C12 frame.

- **Feature 9986**

Feature 9986 is required for a IBM 3590-C12 installed in Chicago.

8.4.2 IBM 3590-B1A Features

Table 13 shows the features for the IBM 3590-B1A drive.

Description	Feature Code
C12 Attachment	2003
ES/9000 Attachment	9000

- **Feature 2003**

Feature 2003 is required on a IBM 3590-B1A to be installed in the IBM 3590-C12. This feature adds a target for the robotic vision system and a holder for the display.

- **Feature 9000**

Feature 9000 should be specified when IBM 3590-B1A will be attached to a ES/3090, ES/9000, or S/390 system.

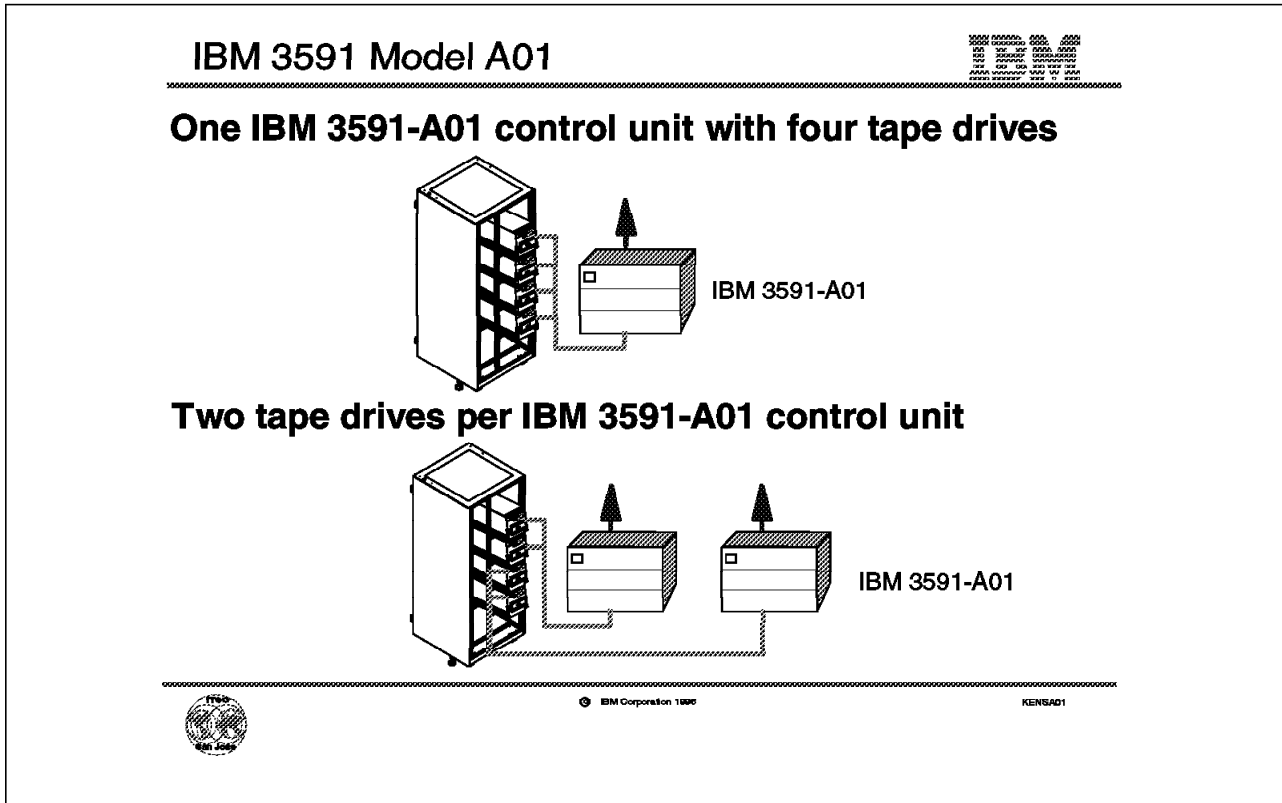

Figure 100. IBM 3591 Model A01

8.5 IBM 3591 Model A01

The primary function of the IBM 3591 Model A01 control unit (Figure 100) is to provide an interface between the SCSI-attached IBM 3590 Magstar drives and the host system ESCON channels. The IBM 3591-A01 ESCON control unit allows the operating system to communicate with the IBM 3590 Magstar drives as if they were IBM 3490E drives.

The IBM 3590-C12 supports attachment of one or two IBM 3591-A01. All four IBM 3590-B1A drives are attached through one SCSI interface to the IBM 3591-A01 in a one-control-unit configuration. Feature 5000 provides a free-standing enclosure for the IBM 3591-A01 that can be used instead of a rack.

When two IBM 3591-A01 control units are used, two IBM 3590-B1A drives are attached through one SCSI port. The first IBM 3591-A01 control unit and the other two IBM 3590-B1A drives are attached through another SCSI interface to the second IBM 3591-A01, as shown in Figure 100. The drives are not attached to both control units. The two-control-unit configuration can be used to improve throughput for certain applications, such as master-in, master-out applications.

The IBM 3591-A01 supports up to 64 logical paths and can be at a maximum channel distance of 43 km from the host.

The IBM 3591-A01 can, as previously announced, be mounted in a rack attaching up to four IBM 3590-B11/B1A drives.

Support for the IBM 3590-C12 Silo-compatible frame together with one or two IBM 3591-A01 ESCON control units is provided in the MVS/ESA operating environment. No new software is required because existing IBM 3490E tape applications also run on IBM 3590-C12.

Table 14 shows which software releases support the IBM 3590-B1A drives attached to an IBM 3591-A01 ESCON controller.

MVS Level	DFP		DFSMS		
	3.3.0	3.3.2	1.1.0	1.2.0	1.3.0
4.2.0	Yes	Yes			
4.2.2	Yes	Yes			
4.3.0	Yes	Yes	Yes	Yes	Yes
5.1.0	Yes	Yes	Yes	Yes	Yes
5.2.0			Yes	Yes	Yes
5.2.2			Yes	Yes	Yes

For more information on software support for the IBM 3591-A01 ESCON controller, see *Magstar and IBM 3590 High Performance Tape Subsystem: Multiplatform Implementation*.

Table 15 shows the physical specifications of the IBM 3591-A01 ESCON control unit.

Dimension	Specification
Height	381 mm (15.0 in.)
Width	482.6 mm (19 in.)
Depth (free-standing)	441.3 mm (17.4 in.)
Depth (installed)	533.4 (21 in.) ¹
Weight	40.8 kg (90 lb)
Notes:	
1. The installed depth includes the added length of the front cover and rear plug.	

For more information on environmental specifications, see

- *IBM 3590 Magstar High Performance Tape Subsystem Silo-Compatible Frame Model C12 Introduction, Planning, and User's Guide*.

For additional information about the IBM 3591 Model A01, see:

- *IBM 3591 Tape Control Unit Model A01 Introduction, Planning, and User's Guide.*

8.5.1 IBM 3591-A01 Features

Table 16 shows the features for the IBM 3591-A01 ESCON control unit.

Description	Feature Code
Remote support facility	2700
Remote support switch	2701
Remote support attachment	2702.
ESCON Adapter Card	3311
IBM 3591-A01 Floor-Standing Package	5000

- **Feature 2700**

Feature 2700 attaches a customer-supplied modem for installation, operation, and remote diagnostic support. It should be ordered for the first IBM 3591-A01 in one location. Only one Feature 2700 should be specified for each site, because up to 14 IBM 3591-A01 units can use the same Remote Support Facility (RSF).

- **Feature 2701**

Feature 2701 attaches to multiple IBM 3591-A01 ESCON control units to the Remote Support Facility (Feature 2700). It should be ordered for the second IBM 3591-A01 in one location. Only one Feature 2701 should be ordered for each customer site.

- **Feature 2702**

Feature 2702 attaches to the Remote Support Facility (Feature 2700). It should be ordered for the third through fourteenth IBM 3591-A01 in one location. Only one Feature 2701 should be ordered for each site.

Note: Each IBM 3591-A01 must specify either Feature 2700, Feature 2701, or Feature 2702. All are plant or field installable.

- **Feature 3311**

An ESCON adapter card, Feature 3311, is required on all IBM 3591-A01 ESCON controllers; it provides an ESCON channel for attachment to a host processor ESCON channel or to a port of an IBM ESCON director. A SCSI adapter is included for attachment of IBM 3590-B1A drives on a SCSI bus. Only one Feature 3311 is needed for plant installation.

- **Feature 5000**

Feature 5000 provides the hardware necessary to have the IBM 3591-A01 as a free-standing box, not requiring a rack.

ESCON cables are ordered with the IBM 3591-A01 ESCON control unit. For information on ordering ESCON cables, refer to:

- *IBM 3591 Tape Control Unit Model A01 Introduction, Planning, and User's Guide.*

Esoteric unit names are used to steer allocation inside and outside the StorageTek Automated Cartridge System. More information on allocation is given in Section 8.7, "Multi-ATL Scratch Tape Allocation" on page 229 and Section 8.8, "Multi-ATL Specific Tape Allocation" on page 231.

- **HSC 2.x**

The following tape device combinations are allowed when using 3590 drives in a StorageTek Automated Cartridge System under HSC 2.x:

1. IBM 3590 only
2. StorageTek 4480, SD-3 or both, plus and IBM 3590
3. StorageTek 4480, SD-3 or both, plus StorageTek 4490 and IBM 3590
4. StorageTek 4480, SD-3 or both, plus StorageTek 9490 and IBM 3590

The IBM 3590 drives emulate StorageTek 4490 **or** 9490 drives, and cannot be introduced into the Automated Cartridge System if 4490 **and** 9490 tape drives are present.

Use explicit ranges of VOLSERS for IBM 3590 media. The following volume attribute definitions are suggested to manage drive-media relationships:

- One or more statements for IBM 3590 Data Cartridges to identify 3590 tapes as a unique media type associated exclusively with the recording technology of the model type they emulate (StorageTek 4490 or 9490).
- One statement for IBM 3590 Cleaning Cartridges; the same media and recording technology attributes used for IBM 3590 Data Cartridges should be applied.
- Additional statements as required to associate media for other drive types with their appropriate recording technology.
- A statement to designate a default recording technology. In a mixed configuration do not specify the IBM 3590 media as the default.

Unit attribute statements are needed to associate IBM 3590 drives with the model type they emulate. Esoteric unit names are used to steer allocation inside and outside the Automated Cartridge System. More information on allocation will be given in Section 8.7, "Multi-ATL Scratch Tape Allocation" on page 229 and Section 8.8, "Multi-ATL Specific Tape Allocation" on page 231.

For additional information on how to define devices and cartridges to HSC, see:

- *StorageTek Host Software Component (MVS/XA-ESA Implementation) System Programmers Guide, Release 1.2, 4044266-2*
- *StorageTek Host Software Component MVS System Programmers Guide, Release 2.0.1, 112156401.*

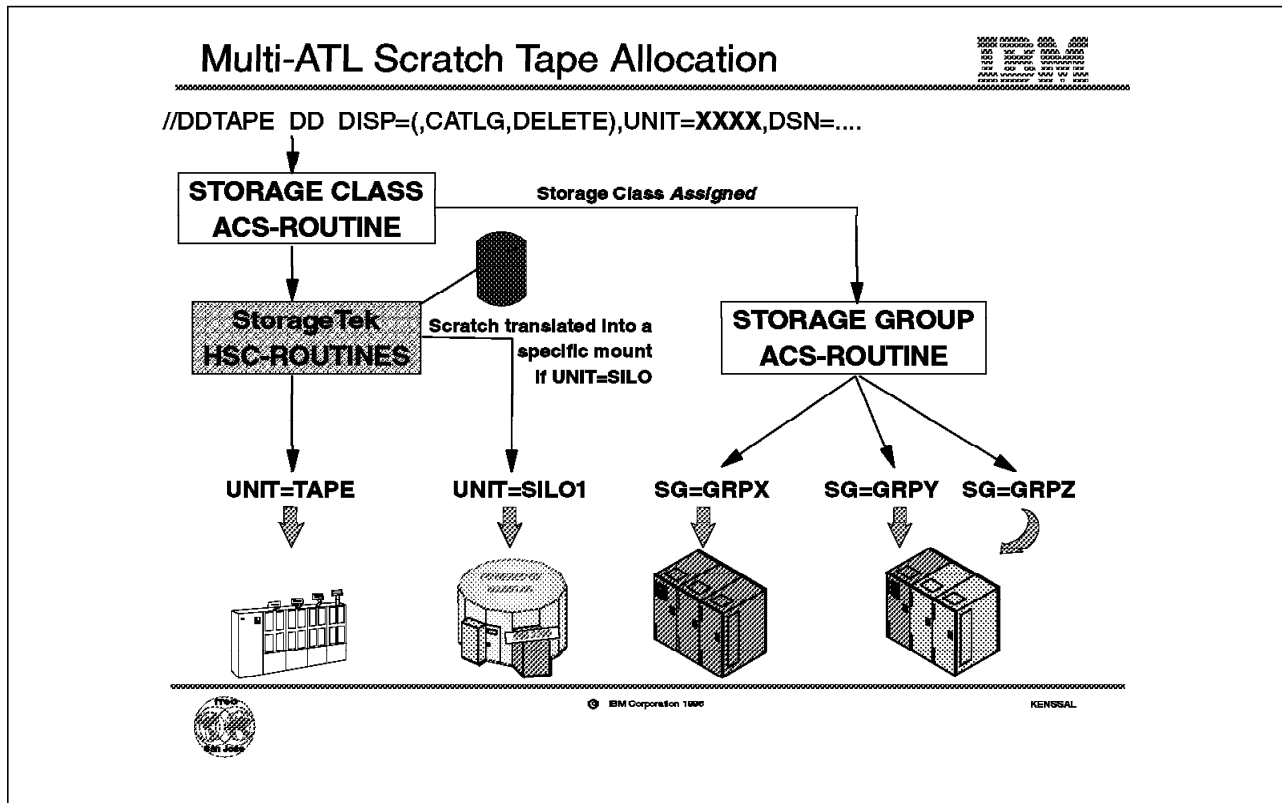

Figure 102. Multi-ATL Scratch Tape Allocation

8.7 Multi-ATL Scratch Tape Allocation

When you decide to install an IBM 3494 or IBM 3495 Automatic Tape Library Dataservers beside an already installed StorageTek Silo to make a smooth migration, you need to know which data is written on which cartridges in which library. This section describes how new tape allocations, that is scratch allocations, are handled in a multivendor tape library installation (Figure 102).

When the IBM Automatic Tape Library is installed, you define it to DFSMS/MVS and define groups for the tape volumes that will be system-managed storage groups. You also add some statements to the automatic class selection routines of DFSMS/MVS to direct new allocations to the correct tape storage groups. For more information on how to implement system managed tape, see:

- *IBM 3495 Implementation Primer for MVS.*

When you define a JCL statement, requesting a scratch tape, the information is first passed to the DFSMS automatic class selection (ACS), routines. If the logic of the Storage Class ACS routine assigns a storage class to this request, the volume requested by this allocation will be system managed. The logic of the storage group ACS routine then assigns a storage group to this allocation. The storage group name is then used by MVS allocation to direct this scratch request to the library or libraries defined to host it. A scratch volume is selected by the Library Manager in the library selected.

If the storage class ACS routine does not assign a storage class to this request, it is not system managed, and is handled as a traditional scratch tape allocation.

| After DFSMS, the StorageTek HSC routines will pick up this tape scratch
| allocation. If the allocation request is directed to an esoteric unit name defined
| for the tape drives in a Silo, the HSC software will select a scratch volume from
| the Control Data Set and turn this allocation into a specific allocation.

| If the scratch allocation is for a unit-name not defined for a Silo, the allocation
| will go to some tape drive of the requested type outside the tape libraries. The
| operator is then requested to mount a scratch tape, if the scratch request could
| not be satisfied by a cartridge loader on the tape drive.

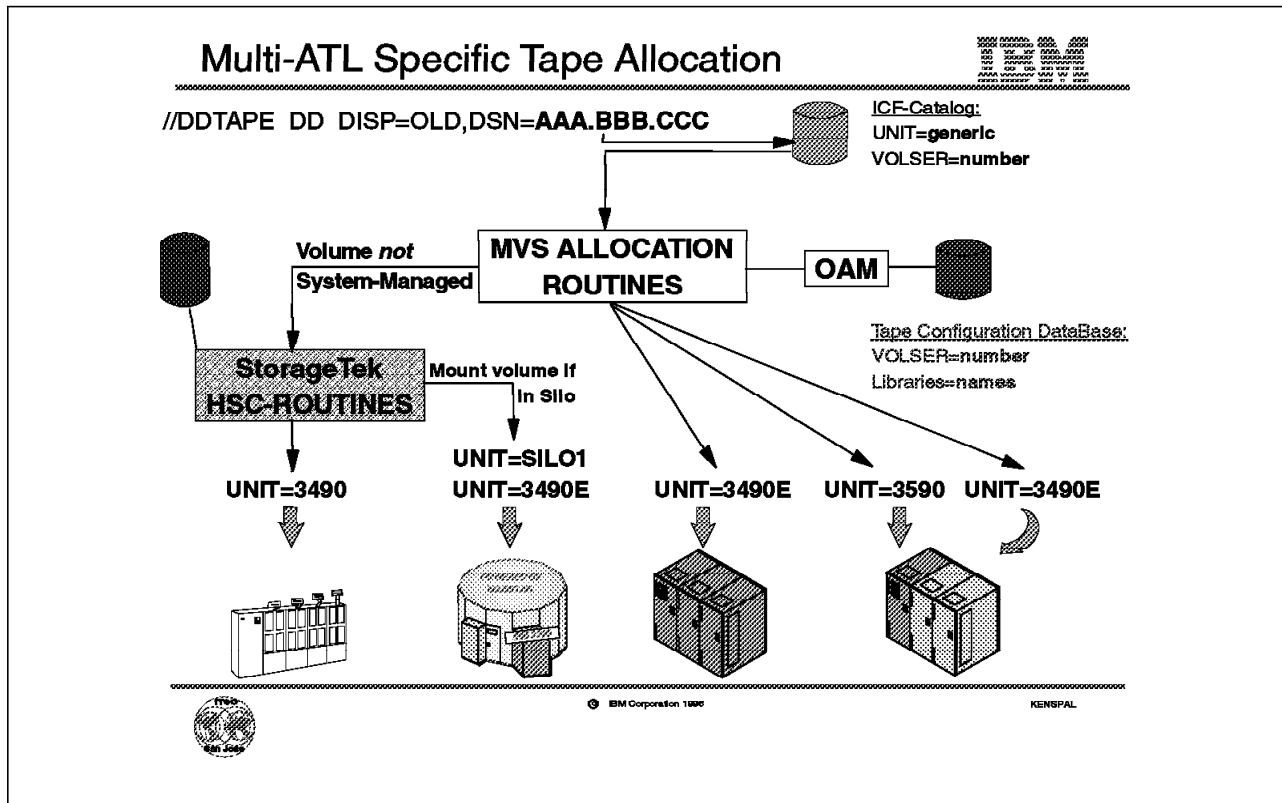

Figure 103. Multi-ATL Specific Tape Allocation

8.8 Multi-ATL Specific Tape Allocation

As described in Section 8.7, “Multi-ATL Scratch Tape Allocation” on page 229 you can use system managed tape together with a StorageTek Silo for scratch requests, once data is created. This section describes how stored data can then be retrieved.

The most common request for data already stored in your system is to specify the name of the data set and specify disposition OLD or SHR, as shown in Figure 103. MVS routines extract the unit and volume information from the system catalog, if it is not specified in the allocation request.

MVS allocation together with the library support routines included in DFSMS Object Access Method (OAM) component and information in the Tape Configuration Database (TCDB), will see if this is a system-managed tape, and if so, in which library the tape is stored. For all system-managed tapes, MVS allocation directs the allocation to the drives installed in the library containing the tape.

If the tape is not system managed, the StorageTek HSC routines see the allocation request afterward. The HSC routines check the control data set to find in which Silo the tape is stored and which drives to use in order to mount the volume. The HSC routines update the allocation information and send the mount order to the robotics in the Silo.

If the tape is not system-managed, and is not defined in the HSC control data set, the allocation is directed to any stand-alone tape drive that can satisfy the

| request. The operator is then requested to mount the tape on the allocated tape
| drive.

Installation and Operation

0000 000000 000 0000
0000 000000 000 0000
00 00 00 0000 0000
00 00000 00000000
00 000000 00000000
00 00 00 000000
0000 000000 000 0000
0000 000000 000 0000

Steps to install

1. Install PTFs
2. DFSMS/MVS IOGEN
3. Cleaning program
4. HSC updates
5. Hardware installation
6. Restart HSC

Operational procedures

- Manual mode
- Drive cleaning
- External labels
- Inventories and catalogs



© IBM Corporation 1990

KENSIAD

Figure 104. Installation and Operation

8.9 Installation and Operation

This section describes the installation of the IBM 3590-C12 and IBM 3591-A01 and explains operation procedures for the installation.

8.9.1 Installation

We describe six installation steps:

1. *Install PTFs*

No new software releases are required to use the IBM 3590-C12. The IBM 3591-A01 ESCON controller emulates the IBM 3490E, and functions with existing system-level and application software. The software restrictions, limitations, and maintenance associated with IBM 3591-A01 apply to IBM 3590-C12.

Table 17 on page 234 shows the Authorized Program Analysis Reports (APARs) that should be installed in order to exploit the full capacity of the IBM 3590 Magstar Cartridges.

<i>Table 17. APARs</i>	
Software Component	APAR number
DFHSM	OW20500
DFSMSHsm	OW20192
DFDSS V2.5 (FMID HAE2502)	PN74583 PN77830
DFSMSdss 1.1.0, 1.2.0, 1.3.0 (FMID JDZ1120, HDZ11B0, HDZ11C0)	OW14835 OW16802

The APARs are described as followed:

- **APARS OW20500 and OW20192**

These allow the TAPE UTILIZATION to be specified with four digits, that is up to 9999. This function is needed in order to utilize the Magstar cartridge capacity if the tape utilization option is not NOLIMIT.

- **APARS PN74583 and OW14835**

These implement the new BUILDSA command and provide stand-alone support for restoration from a file that is not the first file on the tape.

- **APARS PN77830 and OW16802**

provide support for restoration from a file that is not the first file on the tape.

For more information refer to:

- *IBM 3591 Tape Control Unit Model A01 Introduction, Planning, and User's Guide.*

Your IBM installation planning representative and IBM marketing representative can determine the latest levels of software, microcode, and hardware available for your subsystem.

2. **Install DFSMS/MVS IOGEN**

Each IBM 3591-A01 ESCON control unit can have only one logical path specified to each host image. Specify four addresses for all IBM 3591-A01 control units, even if only two devices are attached.

Specify the IBM 3590-B1A drives as 3490E devices.

You also need to define an esoteric unit name for the devices as the StorageTek HSC uses it to direct the allocations.

3. **Set Cleaning program**

The drive cleaning mode is determined at installation; the service representative either enables or disables automatic cleaning for each IBM 3590-B1A drive. In automatic cleaning, a drive informs the Automated Cartridge System that cleaning is required; the Automated Cartridge System then delivers a cleaning cartridge to the drive. When automatic cleaning is disabled, the operator runs a job that mounts a cleaning cartridge (see Appendix A, "Sample Cleaning Program" on page 241 and Figure 106 on page 241).

In a mixed-drive environment, automatic cleaning is performed for non-3590 drives, while cleaning jobs are scheduled at regular intervals for IBM 3590-B1A drives. If there are no mixed media in the Automated Cartridge

System and only 3590 drives are present, then automatic cleaning can be enabled.

Install the cleaning job and the cleaning program even if automatic cleaning is enabled. You find information on how to obtain the necessary MVS JCL and source code of the cleaning program in Appendix A, "Sample Cleaning Program" on page 241.

4. ***Make HSC updates possible***

Define one or more statements for IBM 3590 Data Cartridges to identify tapes as:

- Long media operated with 36-track recording technology if HSC 1.2 is used
- A unique media type associated exclusively with the recording technology of the model type they emulate (4490 or 9490) if HSC 2.x is used.

Define one statement for IBM 3590 Cleaning Cartridges (prefix **MGC**); the same media and recording technology attributes used for IBM 3590 Data Cartridges should be applied.

The IBM 3590 Diagnostic Cartridges (prefix **DGC**) are not to be defined to the HSC.

Define unit attribute statements to associate IBM 3590-B1A drives with the model type they emulate.

Add statements as required to associate media for other drive types with their appropriate recording technology. Esoteric unit names are used to steer allocation inside and outside the StorageTek Automated Cartridge System.

Add one statement to designate a default recording technology. In a mixed configuration do not specify the IBM 3590 media as the default.

In an Automated Cartridge System that has only IBM 3590-B1A drive, the cleaning prefix for autocleaning can be set to **MGC**, and the drives themselves can be configured to request autocleaning. See also Section 8.9.2, "Operation" on page 236.

5. ***Install Hardware***

Relocate the cartridges in the LSM drive panel (top four and bottom four cartridge arrays) into which the IBM 3590-C12 is to be installed. This action is not necessary if you audit the LSM panel when the LSM is varied online.

Setup and verify the IBM 3590-C12 and IBM 3591-A01 before the LSM is taken offline. During installation, the LSM is offline for approximately 2 hours. Total installation time is 6.5 hours.

6. ***Restart the Host Component Software***

After the hardware is installed:

- a. Stop the HSC
- b. Run the reconfiguration program.
- c. Start HSC, with new LIBGEN and control statements in place.
- d. Enter IBM 3590 Magstar data and cleaning cartridges into the LSM.

8.9.2 Operation

Four types of operation are described:

- **Manual mode**

Varying the Library Storage Module (LSM) offline while the HSC is active allows you to enter the LSM and load cartridges manually into the IBM 3590-B1A drives. To load a cartridge manually, with the metal washer facing down, gently slide the cartridge into the drive's loading slot until it stops. Then, push the cartridge into the drive; after you push the cartridge about 1.5 cm into the drive, the loading mechanism pulls the cartridge into the drive and completes the load.

Some LSM actions can leave the drive unable to load a cartridge on the first mount after opening the LSM door. If pushing the cartridge into the drive fails to start the loader, leave the cartridge in the slot and select ALLOW LOAD on the display panel main menu. This should start the load. If it does not, remove the cartridge and repeat the manual loading procedure.

In manual mode, the panel displays the cartridge VOLSER and LSM cell coordinates.

- **Drive cleaning**

When IBM units are intermixed with StorageTek drives and media in an Automated Cartridge System, special measures are required to ensure that the IBM 3590 cleaning cartridges are mounted on IBM 3590-B1A drives, and StorageTek cleaning cartridges are mounted on StorageTek drives. Since a single cleaning prefix is available in support of all tape drives in an Automated Cartridge System, either IBM 3590-B1A drives or StorageTek drives, but not both, can be enabled for automatic cleaning.

At installation, the IBM 3590-B1A drives are configured to either enable or disable autocleaning in the Automated Cartridge System environment. It is recommended that IBM 3590 drives be enabled for autocleaning only when they are in an Automated Cartridge System containing only IBM 3590 drives and media. In a mixed-drive or mixed media Automated Cartridge System, the IBM 3590 drives are configured so that they do not request cleaning. Autocleaning is enabled for the Automated Cartridge System, but will be requested only by the StorageTek drives. IBM 3590-B1A drive cleaning is accomplished through special, regularly scheduled jobs that request mounting of an IBM 3590 cleaning cartridge on a specific IBM 3590 drive. Typically, once every day is sufficient; customize your cleaning schedule based on drive usage.

An example of a drive cleaning program and job control language can be obtained through FTP service. See Appendix A, "Sample Cleaning Program" on page 241 for more information. The cleaning program in that example receives a drive address as an input parameter. Defined constants in the program specify the cleaning prefix **MGC** and the high and low sequence numbers, 000-020, for the range of available cleaning cartridges. An additional defined constant specifies the maximum number of times that a cleaning cartridge should be used.

The example program searches for a suitable cleaning cartridge by starting at the low end of the range and issuing an SLSXREQ QVOLUME command for the VOLSER. If a cartridge is encountered that has been mounted for the maximum number of times, it is ejected from the library by means of SLSXREQ EJECT.

The sample cleaning program and the JCL are optimized for cleaning drives successively rather than concurrently. Four job steps are used to request the cleaning of each IBM 3590 tape drive in the IBM 3590-C12 frame.

- **External labels**

Typically, J is the media identification character for the IBM Magstar 3590 High Performance Tape Cartridge and is in the seventh character position. For IBM 3590-C12, cartridges without a media identification character are recommended for the reasons listed below.

The following consequences occur when using J-labeled cartridges:

- Warning messages appear on the operator console when the library vision system encounters this unexpected J media type
- Redundant robotic movements occur during the physical mounting of J-labeled cartridges
- J-labeled cartridges cannot be entered temporarily into the Automated Cartridge System to satisfy specific mount requests.

You can use J-labeled cartridges that are already present, but be aware of the effects listed above. It is recommended that the J labels be removed.

When existing J-labeled cartridges associated with IBM automated or stand-alone libraries or drives are requested for temporary or permanent entry in an Automated Cartridge System, the J can be removed or temporarily concealed to allow the cartridge to be used without the effects listed above.

Note: IBM Magstar 3590 cartridges without J-labels can be used effectively in IBM tape libraries and distinguished from other media types.

- **Inventories and catalogs.**

Inventories and catalogs that associate 3590 datasets with emulated 3490E tape units require future modification when the 3590 device type is introduced as a native device.

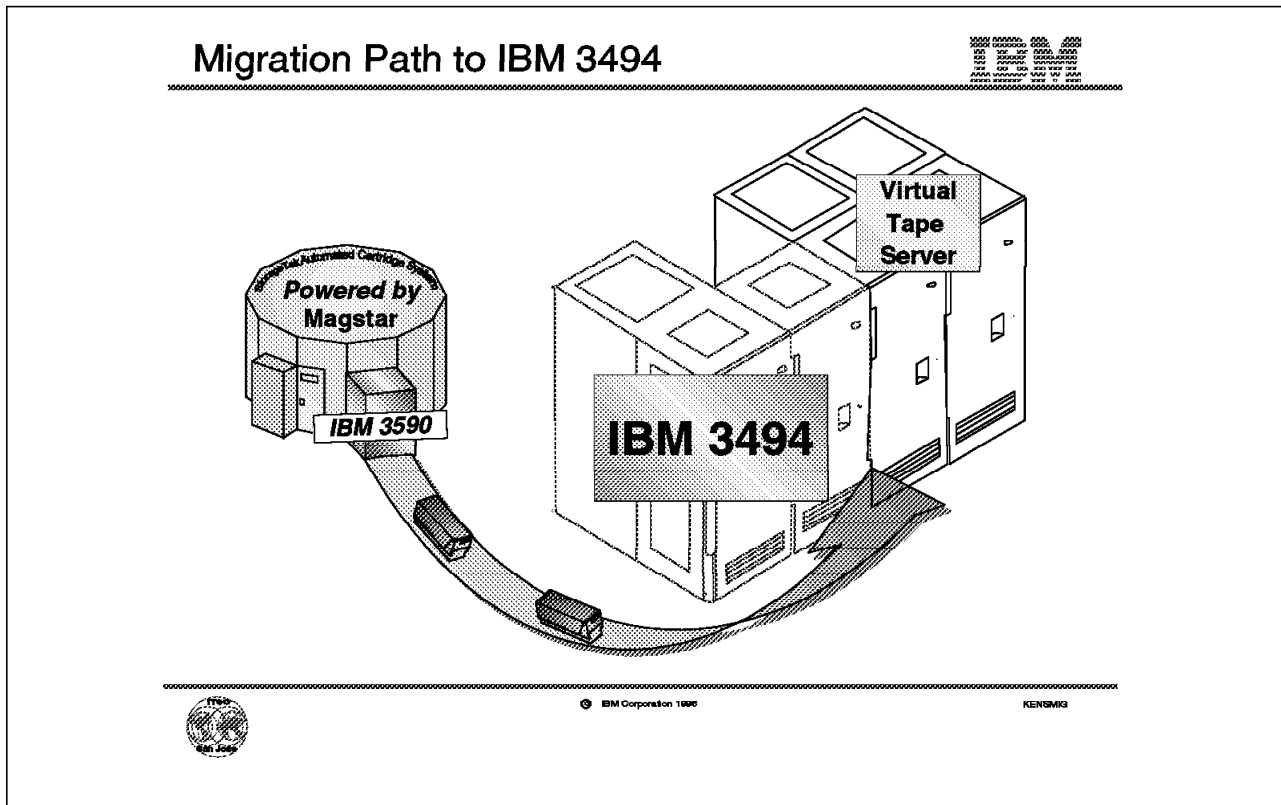

Figure 105. Migration Path to IBM 3494

8.10 Migration Path to IBM 3494

Even if attaching IBM 3590-B1A Magstar tape drives to a StorageTek Silo gives your installation many benefits, you may consider migrating to an IBM Automatic Tape Library. Such a migration will give your tape subsystem many additional functions and enhancements:

- **Investment protection**

The investment you have already made in the IBM Magstar technology can now be further exploited by, for example, using the IBM 3590 drives and cartridges in a Virtual Tape Server to improve the utilization of already installed tape space.

- **Native IBM 3590 support**

Moving the installed IBM 3590-B1A drives from the IBM 3590-C12 frame and installing them in an IBM 3494-L14, IBM 3494-D14, or IBM 3590-A14 frame gives you native 3590 support.

- **Reduced floor space**

Installing the IBM 3590-C12 frame in your StorageTek Silo drastically reduces the number of cartridges needed, perhaps by as much as 50 times. For this reason, you may not need more than one or a few IBM 3494 frames to host all the cartridges in your installation.

- **System-managed tape**

System-management of tape gives tape allocations all the benefits of system-managed dataset. DFSMS automatically stores your tape data,

| application data, DFHSM/ADSM or other migrated data, interchange data,
| archive data, local backup copies, or disaster backups copies, in the
| appropriate tape library or the real or virtual tape server. It does all of this
| using the technology of your choice, IBM 3490, IBM 3490E (real or virtual), or
| IBM 3590, and selects the cartridge type defined in DFSMS without any JCL
| changes.

- ***Virtual Tape Server***

| The IBM 3590-B1A drives can also be moved into an IBM 3494-D12 frame.
| Used together with an IBM 3494-B16 frame, the combination forms a IBM
| Virtual Tape Server. This configuration will give you all the benefits of virtual
| tape support described in this book.

Appendix A. Sample Cleaning Program

An example of a drive cleaning program, and job control language, can be obtained over the Internet through file transfer protocol (FTP) server. The name of the anonymous FTP server is *index.storsys.ibm.com*. Access the FTP server as you would an anonymous service. The driver and documentation are in directory */devdrv*.

In summary:

FTP site: index.storsys.ibm.com
URL: ftp://index.storsys.ibm.com/devdrv
User: anonymous
Password: <email>
Files: /devdrv/3590_C12/README
/devdrv/3590_C12/clean_asm /* 370 assembler source example */

```
//CLEANMAG JOB 000,MSGLEVEL=(1,1)
//*
//CLNMAG PROC DEVNO=
//CLNDRV EXEC PGM=CLEANDRV,PARM='&DEVNO'
//STEPLIB DD DISP=SHR,DSN=YOUR.LINKLIB * LIBRARY CONTAINING PROGRAM
// DD DISP=SHR,DSN=SLS.SLSLINK * LIBRARY CONTAINING STK-CODE
//DUMDD DD UNIT=(&DEVNO,,DEFER) * STOP OTHERS USING DRIVE
// PEND
//
//*
//CLNE50 EXEC CLNMAG,DEVNO=E50
//CLNE51 EXEC CLNMAG,DEVNO=E51
//CLNE52 EXEC CLNMAG,DEVNO=E52
//CLNE53 EXEC CLNMAG,DEVNO=E53
//
```

Figure 106. JCL for Sample Cleaning Program

The sample program requires the device number of the tape drive to be cleaned as a parameter. The device number may be specified with three or four characters.

The return code from this program is:

104	Invalid input
108	Cleaner cartridge not available
R15 after SLSXREQ call	HSC not active
Value of SLXCMDRC	Mount of cleaner cartridge failed

Appendix B. Special Notices

This publication is intended to help customers and IBM technical professionals understand the IBM 3590 High Performance Tape Subsystem that uses the Magstar tape drive. The information in this publication is not intended as the specification of any programming interfaces that are provided by IBM 3590 High Performance Tape Subsystem. See the PUBLICATIONS section for more information about what publications are considered to be product documentation.

References in this publication to IBM products, programs or services do not imply that IBM intends to make these available in all countries in which IBM operates. Any reference to an IBM product, program, or service is not intended to state or imply that only IBM's product, program, or service may be used. Any functionally equivalent program that does not infringe any of IBM's intellectual property rights may be used instead of the IBM product, program or service.

Information in this book was developed in conjunction with use of the equipment specified, and is limited in application to those specific hardware and software products and levels.

IBM may have patents or pending patent applications covering subject matter in this document. The furnishing of this document does not give you any license to these patents. You can send license inquiries, in writing, to the IBM Director of Licensing, IBM Corporation, 500 Columbus Avenue, Thornwood, NY 10594 USA.

Licensees of this program who wish to have information about it for the purpose of enabling: (i) the exchange of information between independently created programs and other programs (including this one) and (ii) the mutual use of the information which has been exchanged, should contact IBM Corporation, Dept. 600A, Mail Drop 1329, Somers, NY 10589 USA.

Such information may be available, subject to appropriate terms and conditions, including in some cases, payment of a fee.

The information contained in this document has not been submitted to any formal IBM test and is distributed AS IS. The information about non-IBM ("vendor") products in this manual has been supplied by the vendor and IBM assumes no responsibility for its accuracy or completeness. The use of this information or the implementation of any of these techniques is a customer responsibility and depends on the customer's ability to evaluate and integrate them into the customer's operational environment. While each item may have been reviewed by IBM for accuracy in a specific situation, there is no guarantee that the same or similar results will be obtained elsewhere. Customers attempting to adapt these techniques to their own environments do so at their own risk.

Any performance data contained in this document was determined in a controlled environment, and therefore, the results that may be obtained in other operating environments may vary significantly. Users of this document should verify the applicable data for their specific environment.

The following document contains examples of data and reports used in daily business operations. To illustrate them as completely as possible, the examples contain the names of individuals, companies, brands, and products. All of these

names are fictitious and any similarity to the names and addresses used by an actual business enterprise is entirely coincidental.

Reference to PTF numbers that have not been released through the normal distribution process does not imply general availability. The purpose of including these reference numbers is to alert IBM customers to specific information relative to the implementation of the PTF when it becomes available to each customer according to the normal IBM PTF distribution process.

The following terms are trademarks of the International Business Machines Corporation in the United States and/or other countries:

ACF/VTAM	ADSTAR
AIX	AIX/ESA
AIX/6000	Application System/400
AS/400	CICS
CICS/ESA	DB2
DFSMS	DFSMS/MVS
DFSMS/VM	DFSMSdfp
DFSMSdss	DFSMShsm
DFSMSrmm	DFSORT
Enterprise System/3090	Enterprise System/4381
Enterprise System/9000	Enterprise System/9370
Enterprise Systems Architecture/370	Enterprise Systems Architecture/390
Enterprise Systems Connection Architecture	ES/3090
ES/4381	ES/9000
ES/9370	ESA/370
ESA/390	ESCON XDF
ESCON	IBM
IMS	IMS/ESA
Magstar	MVS (logo)
MVS/DFP	MVS/ESA
MVS/SP	MVS/XA
OS/390	OS/400
POWERparallel	PR/SM
RISC System/6000	RMF
RS/6000	S/370
S/390	S/390 Parallel Enterprise Server
Scalable POWERparallel Systems	SP2
System/360	System/370
System/390	S/390 Parallel Enterprise Server
Virtual Machine/Enterprise Systems Architecture	VM/ESA
VSE/ESA	VTAM
3090	9076 SP2

The following terms are trademarks of other companies:

C-bus is a trademark of Corollary, Inc.

PC Direct is a trademark of Ziff Communications Company and is used by IBM Corporation under license.

UNIX is a registered trademark in the United States and other countries licensed exclusively through X/Open Company Limited.

Microsoft, Windows, and the Windows 95 logo are trademarks or registered trademarks of Microsoft Corporation.

Java and HotJava are trademarks of Sun Microsystems, Inc.

SunOS, SPARCstation, Network File System, NFS.* Sun Microsystems, Inc.

Other trademarks are trademarks of their respective companies.

Appendix C. Related Publications

The publications listed in this section are considered particularly suitable for a more detailed discussion of the topics covered in this redbook.

C.1 International Technical Support Organization Publications

For information on ordering these ITSO publications see "How To Get ITSO Redbooks" on page 249.

- *Guide to Sharing and Partitioning IBM Automated Tape Library Dataservers*, SG24-4409
- *Magstar and IBM 3590 High Performance Tape Subsystem: Multiplatform Implementation*, SG24-2594.
- *The IBM Magstar Virtual Tape Server and Enhancements to Magstar: New Era in Tape*, SG24-4917.

C.2 Redbooks on CD-ROMs

Redbooks are also available on CD-ROMs. **Order a subscription** and receive updates 2-4 times a year at significant savings.

CD-ROM Title	Subscription Number	Collection Kit Number
System/390 Redbooks Collection	SBOF-7201	SK2T-2177
Networking and Systems Management Redbooks Collection	SBOF-7370	SK2T-6022
Transaction Processing and Data Management Redbook	SBOF-7240	SK2T-8038
AS/400 Redbooks Collection	SBOF-7270	SK2T-2849
RISC System/6000 Redbooks Collection (HTML, BkMgr)	SBOF-7230	SK2T-8040
RISC System/6000 Redbooks Collection (PostScript)	SBOF-7205	SK2T-8041
Application Development Redbooks Collection	SBOF-7290	SK2T-8037
Personal Systems Redbooks Collection	SBOF-7250	SK2T-8042

C.3 Other Publications

These publications are also relevant as further information sources:

- *IBM 3590 High Performance Tape Subsystem Introduction and Planning Guide*, GA32-0329
- *IBM 3590 High Performance Tape Subsystem User's Guide*, GA32-0330
- *IBM 3590 High Performance Tape Subsystem Hardware Reference*, GA32-0331
- *IBM 3590 Magstar High Performance Tape Subsystem Silo-Compatible Frame Model C12 Introduction, Planning, and User's Guide*, GA32-0366.
- *IBM 3591 Tape Control Unit Model A01 Introduction, Planning, and User's Guide*, GA32-0358.
- *IBM 3494 Tape Library Dataserver Introduction and Planning Guide*, GA32-0279
- *IBM 3495 Tape Library Dataserver Introduction and Planning Guide*, GA32-0234

- *IBM SCSI Tape Drive, Medium Changer and Library Device Drivers Installation and User's Guide, GC35-0154*
- *AS/400 Automated Tape Library Planning and Management Version 3, SC41-3309*
- *DFSMS/MVS Version 1 Release 3 Object Access Method Planning, Installation, and Administration Guide for Tape Libraries, SC26-3051*

How To Get ITSO Redbooks

This section explains how both customers and IBM employees can find out about ITSO redbooks, CD-ROMs, workshops, and residencies. A form for ordering books and CD-ROMs is also provided.

This information was current at the time of publication, but is continually subject to change. The latest information may be found at URL <http://www.redbooks.ibm.com>.

How IBM Employees Can Get ITSO Redbooks

Employees may request ITSO deliverables (redbooks, BookManager BOOKs, and CD-ROMs) and information about redbooks, workshops, and residencies in the following ways:

- **PUBORDER** — to order hardcopies in United States
- **GOPHER link to the Internet** - type GOPHER.WTSCPOK.ITSO.IBM.COM
- **Tools disks**

To get LIST3820s of redbooks, type one of the following commands:

```
TOOLS SENDTO EHONE4 TOOLS2 REDPRINT GET SG24xxxx PACKAGE
TOOLS SENDTO CANVM2 TOOLS REDPRINT GET SG24xxxx PACKAGE (Canadian users only)
```

To get lists of redbooks:

```
TOOLS SENDTO WTSCPOK TOOLS REDBOOKS GET REDBOOKS CATALOG
TOOLS SENDTO USDIST MKTTOOLS MKTTOOLS GET ITSOCAT TXT
TOOLS SENDTO USDIST MKTTOOLS MKTTOOLS GET LISTSERV PACKAGE
```

To register for information on workshops, residencies, and redbooks:

```
TOOLS SENDTO WTSCPOK TOOLS ZDISK GET ITSOREGI 1996
```

For a list of product area specialists in the ITSO:

```
TOOLS SENDTO WTSCPOK TOOLS ZDISK GET ORGCARD PACKAGE
```

- **Redbooks Home Page on the World Wide Web**

<http://w3.itso.ibm.com/redbooks>

- **IBM Direct Publications Catalog on the World Wide Web**

<http://www.elink.ibm.link.ibm.com/pb1/pb1>

IBM employees may obtain LIST3820s of redbooks from this page.

- **REDBOOKS category on INEWS**
- **Online** — send orders to: USIB6FPL at IBMMAIL or DKIBMBSH at IBMMAIL
- **Internet Listserver**

With an Internet E-mail address, anyone can subscribe to an IBM Announcement Listserver. To initiate the service, send an E-mail note to announce@webster.ibm.link.ibm.com with the keyword subscribe in the body of the note (leave the subject line blank). A category form and detailed instructions will be sent to you.

How Customers Can Get ITSO Redbooks

Customers may request ITSO deliverables (redbooks, BookManager BOOKs, and CD-ROMs) and information about redbooks, workshops, and residencies in the following ways:

- **Online Orders** (Do not send credit card information over the Internet) — send orders to:

	IBMMAIL	Internet
In United States:	usib6fpl at ibmmail	usib6fpl@ibmmail.com
In Canada:	caibmbkz at ibmmail	lmannix@vnet.ibm.com
Outside North America:	dkibmbsh at ibmmail	bookshop@dk.ibm.com

- **Telephone orders**

United States (toll free)	1-800-879-2755
Canada (toll free)	1-800-IBM-4YOU
Outside North America	(long distance charges apply)
(+45) 4810-1320 - Danish	(+45) 4810-1020 - German
(+45) 4810-1420 - Dutch	(+45) 4810-1620 - Italian
(+45) 4810-1540 - English	(+45) 4810-1270 - Norwegian
(+45) 4810-1670 - Finnish	(+45) 4810-1120 - Spanish
(+45) 4810-1220 - French	(+45) 4810-1170 - Swedish

- **Mail Orders** — send orders to:

IBM Publications Publications Customer Support P.O. Box 29570 Raleigh, NC 27626-0570 USA	IBM Publications 144-4th Avenue, S.W. Calgary, Alberta T2P 3N5 Canada	IBM Direct Services Sortemosevej 21 DK-3450 Allerød Denmark
--	--	--

- **Fax** — send orders to:

United States (toll free)	1-800-445-9269
Canada	1-403-267-4455
Outside North America	(+45) 48 14 2207 (long distance charge)

- **1-800-IBM-4FAX (United States) or (+1) 415 855 43 29 (Outside USA)** — ask for:

Index # 4421 Abstracts of new redbooks
Index # 4422 IBM redbooks
Index # 4420 Redbooks for last six months

- **Direct Services** - send note to softwareshop@vnet.ibm.com

- **On the World Wide Web**

Redbooks Home Page	http://www.redbooks.ibm.com
IBM Direct Publications Catalog	http://www.elink.ibm.com/pbl/pbl

- **Internet Listserver**

With an Internet E-mail address, anyone can subscribe to an IBM Announcement Listserver. To initiate the service, send an E-mail note to announce@webster.ibm.com with the keyword `subscribe` in the body of the note (leave the subject line blank).

IBM Redbook Order Form

Please send me the following:

Title	Order Number	Quantity
-------	--------------	----------

- Please put me on the mailing list for updated versions of the IBM Redbook Catalog.
-

First name	Last name
------------	-----------

Company

Address

City	Postal code	Country
------	-------------	---------

Telephone number	Telefax number	VAT number
------------------	----------------	------------

- Invoice to customer number _____

- Credit card number _____
-

Credit card expiration date	Card issued to	Signature
-----------------------------	----------------	-----------

We accept American Express, Diners, Eurocard, Master Card, and Visa. Payment by credit card not available in all countries. Signature mandatory for credit card payment.

DO NOT SEND CREDIT CARD INFORMATION OVER THE INTERNET.

Index

Numerics

- 128TRACK
 - ALTER AMS command 108
 - CREATE AMS command 108
 - data class 107
 - dynamic allocation 103
- 16-track 15
- 18-track 15
- 3590-1
 - generic unit name 102
- 3M Corporation
 - IBM 3590 High Performance Tape Cartridge 37
- 8B3166
 - RPQ 84
- 8B3167
 - RPQ 84
- 8B3168
 - RPQ 84

A

- Access Method Services
 - See AMS
- accumulate mode
 - ACF 6, 48, 53, 55
 - disabling conditions 54, 56
 - operational flow 53, 56
- ACF 6, 28
 - accumulate mode 6, 48, 53, 55
 - ADSM 127
 - automatic mode 49
 - cartridge magazine 6
 - device driver 123, 125
 - enabling and disabling 62
 - export position 46, 98
 - import position 46, 99
 - load order 98
 - locking bar 47
 - magazine 41, 46
 - manual mode 48, 51
 - modes of operation 48
 - move order 99
 - operation 39
 - operator panel 40
 - priority cell 40
 - random mode 6, 49, 59, 122
 - read cell status order 99
 - read volume loader data order 99
 - Stage CCW 98
 - status light 41
 - system mode 49, 57
 - transport mechanism 41
 - unload order 98

- ACF mode
 - summary 62
- ACL 6
- ACS 108
- ACS routine
 - scratch allocation 229
 - SMS 108
 - storage class 229
 - storage group 229
- ADSM 4, 18
 - AIX/6000 95, 127
 - high-speed search 100
 - MVS/ESA 94
 - OS/400 95, 122
 - Solaris 127
 - Sun Solaris 95
 - SunOS 127
 - tape space utilization 20
 - VM/ESA 95
 - VSE/ESA 95
- ADSTAR Distributed Storage Manager
 - See ADSM
- AIX/6000 95
 - ADSM 127
 - block size 124
 - IBM 3590 support 123
 - supported configurations 91
 - tape command 124
- algorithm
 - compression 25
- allocation
 - automatic class selection routine 229
 - Host Software Component 231
 - scratch request 229
 - Silo 229, 231
 - specific request 231
 - tape library 229, 231
- alternate IPL
 - OS/400 122
- AMS 108
- AMS command
 - ALTER 108
 - CREATE 108
 - LISTCAT 108
- AS/400
 - configuration 73
 - data rate chart 142
 - Feature 6501 74
 - IBM 3494 Automated Tape Library Dataserver 73
 - Library Manager 74
 - SCSI consideration 74
 - special feature 74
 - supported configurations 91

- autoblocking 25, 143
- Automated Cartridge System
 - cleaning program 234
 - drive cleaning 236
 - operation 236
- Automatic Cartridge Facility
 - See ACF
- Automatic Cartridge Loader
 - See ACL
- automatic class selection
 - See ACS
- automatic mode
 - ACF 49
- automation
 - IBM 3590 High Performance Tape Subsystem 10
 - IBM tape products 19

B

- BAC 7, 25, 133, 144
- Backup Recovery and Media Services/400
 - See BRMS/400
- basic control program
 - See BCP
- Basic Tape Library Support
 - See BTLS
- BCP 101
- binary arithmetic compression
 - See BAC
- block ID 100
 - Virtual Tape Server 205
- block size
 - AIX/6000 124
 - IBM 3490E 138
 - performance 145
 - RISC/6000 76
 - Sun systems 77, 126
- BRMS/400 4, 18, 95, 122
 - high-speed search 100
 - tape space utilization 20
- BTLS 95
 - IBM 3590 support 104
 - supported configurations 91
 - Virtual Tape Server 163, 201

C

- capacity
 - IBM 3490E 19
 - IBM 3590 19
 - IBM 7206 19
 - IBM 7207 19
 - IBM 7208 19
 - IBM 7331 19
 - IBM 7332 19
 - IBM tape products 18
 - TCDB 113
- cartridge capacity 143
 - IBM 3494 85

- cartridge eject exit
 - CBRUXEJC 115
- cartridge eject processing 116
- cartridge entry exit
 - CBRUXENT 115
- cartridge entry processing 116
- cartridge load time 24
- cartridge magazine
 - ACF 6
- cartridge system tape
 - See CST
- cartridge type 37
- casing
 - IBM 3590 High Performance Tape Cartridge 37
- CBROAMxx
 - SYS1.PARMLIB member 113
- CBRTDSI macro
 - TDSI 114
- CBRUXCUA
 - change use attribute exit 115
- CBRUXEJC
 - cartridge eject exit 115
- CBRUXENT
 - cartridge entry exit 115
- CBRUXVNL
 - volume not in library exit 115
- CBRXLCS macro
 - LCS external services 114
- CCW 96
 - IPL Read 97
 - Read Backward 97, 105, 106
 - Read Block ID 97
 - Read Buffered Log 97
 - Read Configuration Data 97, 102
 - Read Device Characteristics 97
 - Read Forward 97, 105, 119
 - Read IPL 119
 - Read Media Characteristics 97
 - Read Previous 97, 105, 106
 - Stage 49, 59, 60, 98
- change use attribute exit
 - CBRUXCUA 115
- channel attachment
 - Virtual Tape Server 151
- channel command 96
- channel command word
 - See CCW
- Checkpoint/Restart
 - IBM 3590 support 106
 - Read Previous CCW 106
- chromium dioxide
 - medium 13, 19
- cleaner cartridge 37
- cleaning program
 - Automated Cartridge System 234
 - IBM 3590 241
 - IBM 3590-B1A 234
 - IBM 3590-C12 241

- cleaning program (*continued*)
 - IBM 3591 tape subsystem 241
 - Silo 234
- CLIO/S 95, 128
- CMS
 - IBM 3590 support 120
- compaction ratio
 - Virtual Tape Server 205
- compression 143
 - algorithm 25
 - BAC 7, 25, 144
 - history buffer 25
 - IBM 3590 25
 - IBMLZ1 7, 25, 144, 145
 - IDRC 25, 144
 - Magstar 25
 - performance 145
 - physical volume 189
 - virtual volume 188
 - Ziv-Lempel 7, 25
- configuration
 - 3495 RS-422 Connections 72
 - AS/400 73
 - ES/9000 66
 - IBM 3494 Automated Tape Library Dataserver 78
 - IBM 3494 Automated Tape Library Dataserver VTS 78
 - IBM 3495 72
 - IBM 3495 Automated Tape Library Dataserver 69, 70, 71
 - IBM 3590 High Performance Tape Subsystem 65
 - IBM 3590-C12 218
 - IBM Magstar Virtual Tape Server (VTS) 70
 - POWERparallel SP2 75, 77
 - RISC/6000 75
 - S/390 Parallel Server 66
 - Silo 218
 - software and hardware support matrix 91
 - StorageTek Automated Cartridge System 218
 - Sun systems 77
 - Virtual Tape Server 72, 154
- control unit frame
 - IBM 3494 Automated Tape Library Dataserver 78
 - IBM 3494-L10 82
 - IBM 3494-L12 82
 - IBM 3494-L14 82
- control unit function
 - IBM 3490-A10 27
 - IBM 3490-C10 27
 - IBM 3590 27
 - Magstar 25, 27
 - schematic comparison 27
 - SCSI-3 25
- control unit initiated reconfiguration
 - See CUIR
- cooling 35
- CST 36
 - logical volume 154

- CST (*continued*)
 - media type 37
 - virtual volume 189
- CUIR 102

D

- DASD data rate
 - performance 145
- DASD Dump Restore
 - See DDR
- data class
 - See also DC
 - 128TRACK 107
 - MEDIA3 107
 - SMS 107
- data compression
 - IBM 3490E 133
- data integrity
 - ECC 17
 - longitudinal recording 17
- data invalidation
 - logical volume 182
 - Virtual Tape Server 182
- data rate
 - IBM 3490E ESCON 132
 - IBM 3490E SCSI 137
 - IBM 3590 ESCON 139
 - IBM 3590 SCSI 140
 - Magstar 25
- data rate chart
 - AS/400 142
 - IBM 3490E 142
 - IBM 3490E ESCON 135
 - IBM 3490E SCSI 138
 - IBM 3590 142
 - IBM 3590 SCSI 141
- Data Security Erase command
 - Virtual Tape Server 205
- data set striping 145
- data transfer rate
 - IBM 3490E 19
 - IBM 3590 19
 - IBM 7206 19
 - IBM 7207 19
 - IBM 7208 19
 - IBM 7331 19
 - IBM 7332 19
- DB2
 - OAM optical configuration database 112
- DC 107
- DCE 102, 103
- DDR 120, 204
 - IBM 3590 support 120
- definition
 - logical volume 198
 - physical volume 199
- degaussing
 - servo track 38

- density
 - IBM 3590 tape 13
 - linear 13
 - track 13
- design targets
 - IBM 3590 High Performance Tape Subsystem 9
- device class extension
 - See DCE
- device coexistence
 - Virtual Tape Server 195
- device driver
 - ACF 123
 - AIX/6000 123
 - feature 5212 for IBM 3590-B1A 123
 - feature 9204 for IBM 3590-B1A 125
 - feature 9603 for IBM 3590-B11 123
 - feature 9710 for IBM 3590-B11 125
 - Library Manager 123, 125
 - service aids 124, 125
 - SunOS 125
- device management command
 - AIX/6000 124
- device preference table 102
- device serial number 106
- DFDSS 95
- DFSMS system-managed tape
 - Virtual Tape Server 200
- DFSMS/MVS 3
 - IBM 3590 support 104
 - random mode 50, 59, 99, 104
 - toleration PTF 94, 104
 - Virtual Tape Server 163
- DFSMS/MVS 1.1.0
 - supported configurations 91
 - toleration PTF 104
- DFSMS/MVS 1.2.0
 - supported configurations 91
 - toleration PTF 104
- DFSMS/VM
 - Virtual Tape Server 164
- DFSMS/VM RMS
 - IBM 3590 support 120
- DFSMSShsm 4, 18
 - command 110
 - high-speed search 100
 - tape space utilization 20
- DFSMSrmm 3, 110
- DFSORT
 - MVS/ESA 94
- dimension
 - IBM 3494-B16 172
 - IBM 3495-B16 179
 - Virtual Tape Server 172, 179
- disabling
 - ACF 62
- disabling conditions
 - accumulate mode 54, 56
 - manual mode 52
- disabling conditions (*continued*)
 - random mode 61
 - system mode 58
- display
 - IBM 3590-C12 221
 - Texas Digital Systems, Inc. (TDS) 221
- DISPLAY SMS,LIBRARY operator command
 - tape library support 115
- DISPLAY SMS,VOLUME operator command
 - tape library support 115
- DITTO/ESA
 - MVS/ESA 94
 - VM/ESA 95
 - VSE/ESA 95
- DJ 118
- drive cleaning
 - Automated Cartridge System 236
 - IBM 3590-B1A 236
 - IBM 3590-C12 236
 - Silo 236
- drive models
 - IBM 3590-B11 28
 - IBM 3590-B1A 28
- drive unit frame
 - IBM 3494 Automated Tape Library Dataserver 78
 - IBM 3494-D10 83
 - IBM 3494-D12 83
 - IBM 3494-D14 83
- DSP 118
- DTYPE
 - IBM 3590 117
- Dump Job
 - See DJ
- dynamic allocation 103
- dynamic device reconfiguration
 - See DDR
- Dynamic Support Program
 - See DSP

E

- ECC 12, 15
 - longitudinal recording 17
- ECCST 19, 36
 - logical volume 154
 - media type 37
 - virtual volume 189
- EDGINERS
 - Virtual Tape Server 181
- effective data rate
 - IBM 3490E 133
- enabling
 - ACF 62
- end-of-data
 - See EOD
- enhanced capacity cartridge system tape
 - See ECCST
- Enterprise Systems Connection
 - See ESCON

Environmental Record Editing and Printing
 See EREP

environmentals 34
 IBM 3494-B16 172
 IBM 3495-B16 179
 Virtual Tape Server 172, 179

EOD
 Virtual Tape Server 205

Erase Gap command
 Virtual Tape Server 205

EREP
 MVS/ESA 94
 Virtual Tape Server 163, 164
 VM/ESA 95
 VSE/ESA 95

ERP 97
 IBM 3590 97, 105

error correcting code
 See ECC

error recovery
 physical volume 211
 Virtual Tape Server 211

error recovery procedure
 See ERP

Error Statistics by Volume 103

ES/9000
 software support 94
 supported configurations 91

ES/9000 configuration
 IBM 3494 Automated Tape Library Dataserver 66
 IBM 3495 Automated Tape Library Dataserver 67
 IBM 3495 Model M10 Manual Tape Library
 Dataserver 67
 IBM 3590-A14 66
 Library Manager 68

ESCON 7
 IBM 3590-A00 30
 supported distance 67
 XDF 67

ESCON adapter
 IBM 3591-A01 226

ESCON channel
 Virtual Tape Server 165

ESCON data rate
 IBM 3490E 132
 IBM 3590 139

ESCON data rate chart
 IBM 3490E 135

ESCON extended distance facility
 See XDF

event logging
 Virtual Tape Server 206
 virtual volume 207

export position 46, 98

extended capacity cartridge system tape
 See ECCST

external label
 IBM 3590 cartridge 237

external label (*continued*)
 IBM 3590-C12 222, 237
 Silo 222, 237

F

Fast-Ready attribute
 logical volume 158, 182
 scratch mount 199
 setting 199
 Virtual Tape Server 182

Feature
 2416 76
 2420 76
 5212 123
 5300 83, 84
 5302 83, 84
 5304 83, 84
 5400 83, 84
 6501 74
 9204 125
 9603 123
 9701 76
 9702 76
 9710 125
 IBM 3494-L10 83

Features
 IBM 3494 169
 IBM 3494-B16 170
 IBM 3495 177
 IBM 3495-B16 177
 IBM 3590 86
 IBM 3590-B1A 223
 IBM 3590-C12 222
 IBM 3591-A01 226
 Remote Support Facility 226
 Virtual Tape Server 169, 177

FID 45
 message 45

field replaceable unit
 See FRU

FILEDEF
 CMS command 120

forward space 24

FRU 45

FRU identification
 See FID

G

generic unit name
 3590-1 102

guest operating system support
 IBM 3590 119

H

half-inch cartridge tape
 helical scan 5

- half-inch cartridge tape (*continued*)
 - history 5
 - IBM 3590 High Performance Tape Subsystem 5
 - longitudinal recording 5
- hardware configuration definition
 - See HCD
- HCD 67, 101
 - library device group name 117
 - virtual device 157
 - Virtual Tape Server 157, 198
- HDR2/EOV2/EOF2 106
- head wear
 - longitudinal recording 17
- heads 15
- helical scan 12
 - half-inch cartridge tape 5
 - IBM 3850 Mass Storage System (MSS) 5
 - RedWood SD-3 Helical Cartridge Tape Subsystem 215
- Hierarchical Storage Manager 110
 - See also HSM
- high-speed locate 24
- high-speed search 16, 100
 - ADSM 127
- history
 - half-inch cartridge tape 5
 - IBM 3480 3
 - IBM 3490E 3
 - IBM 3590 3
 - IBM 3590 High Performance Tape Subsystem 4
 - IBM 726 3
 - tape technology 2
- history buffer 25
- host connection
 - performance 145
- host interface
 - IBM 3490E 90
 - IBM 3590 90
- HSC
 - device combination 227, 228
 - IBM 3590 227, 228
 - installation 235
 - level 2.1 227
 - level 2.x 228
 - specific allocation 231
 - StorageTek 4480 228
 - StorageTek 4490 228
 - StorageTek 9490 228
 - StorageTek SD-3 228
- HSM 3

I

- I/O configuration program
 - See IOCP
- IBM 2401 2
- IBM 2420 2
- IBM 3420 2
- IBM 3480
 - history 3
- IBM 3480 compatible
 - 4480 Cartridge Tape Subsystem 214
- IBM 3490 2
 - ICL 40
- IBM 3490-A10 27
- IBM 3490-C10 27
- IBM 3490E 19
 - AS/400 data rate chart 142
 - data compression 133
 - effective data rate 133
 - ESCON data rate 132
 - ESCON data rate chart 135
 - history 3
 - host interface 90
 - native data rate 132
 - SCSI data rate 137
 - SCSI data rate chart 138
 - Silo 216
 - supported configurations 91
- IBM 3490E compatible
 - Silverton 4490 Cartridge Subsystem 215
 - Timberline 9490 Cartridge Tape Subsystem 215
- IBM 3494
 - cartridge capacity 85
 - features 169
 - media type 37
 - model upgrades 171
 - scratch allocation 229
 - Virtual Tape Server 151
 - Virtual Tape Server configuration 154, 160, 167
- IBM 3494 Automated Tape Library Dataserver 28
 - AS/400 configuration 73
 - configuration 78
 - control unit frame 78, 82
 - drive unit frame 78, 83
 - ES/9000 and S/390 configuration 66
 - IBM 3494-B16 80, 83
 - mixed configuration 80
 - POWERparallel SP2 configuration 75
 - RISC/6000 configuration 75
 - sharing 81
 - storage unit frame 78, 83
 - summary 82
 - Virtual Tape Server 80
 - VTS unit frame 83
- IBM 3494 support
- IBM 3494-B16
 - dimension 172
 - environmentals 172
 - features 170
 - Library Manager attachment 165
 - Remote Support Facility 168
 - Virtual Tape Server 21, 80, 148
 - Virtual Tape Server configuration 161, 167
- IBM 3494-D10 83
 - Virtual Tape Server configuration 161

- IBM 3494-D12 83
 - Library Manager attachment 165
 - Virtual Tape Server configuration 161
- IBM 3494-D14 83
 - Virtual Tape Server configuration 161
- IBM 3494-L10 79, 82
 - Feature 83
 - model upgrade 83
 - Virtual Tape Server configuration 160
- IBM 3494-L12 79, 82
 - Virtual Tape Server configuration 160
- IBM 3494-L14 79, 82
 - Virtual Tape Server configuration 160
- IBM 3494-S10 83
 - Virtual Tape Server configuration 161
- IBM 3495
 - Configuration 72
 - features 177
 - frame replacement 175
 - Library Manager attachment 174
 - media type 37
 - RS-422 Connections 72
 - RTIC Ports 72
 - scratch allocation 229
 - Virtual Tape Server 22, 72, 149, 151
 - Virtual Tape Server configuration 155, 161, 173
- IBM 3495 Automated Tape Library Dataserver
 - configuration 69
 - ES/9000 and S/390 configuration 67
 - IBM 3590-A00 32
 - IBM 3590-A14 32
 - IBM 3590-B11 32
 - IBM Magstar Virtual Tape Server (VTS) 70
 - Library Manager 70
 - mixed configuration 71
- IBM 3495 Model M10 Manual Tape Library Dataserver
 - AS/400 7
 - ES/9000 7
 - ES/9000 and S/390 configuration 67
 - IBM 3590 High Performance Tape Subsystem 7, 32
 - POWERparallel SP2 7
 - RISC/6000 7
 - S/390 Parallel Server 7
 - Sun systems 7
- IBM 3495 support
- IBM 3495-B16
 - dimension 179
 - environmentals 179
 - features 177
 - Remote Support Facility 174
 - Virtual Tape Server 22, 149
 - Virtual Tape Server configuration 173
- IBM 3495-L20 69
- IBM 3495-L30 69
- IBM 3495-L40 69
- IBM 3495-L50 69
- IBM 3590 19
 - alternate IPL 122
 - AS/400 data rate chart 142
 - Checkpoint/Restart 106
 - cleaning cartridge 227
 - data cartridge 227
 - drive models 28
 - ESCON data rate 139
 - Features 86
 - host interface 90
 - Host Software Component 227
 - menu control switch 43
 - mode switch 42
 - OPEN/CLOSE/EOV 106
 - operator panel 42
 - operator panel screen 44
 - power-on reset 42
 - reset switch 42
 - sample cleaning program 241
 - schematic comparison 27
 - SCSI data rate 140
 - SCSI data rate chart 141
 - supported configurations 91
 - Virtual Tape Server 21, 148, 151
- IBM 3590 cartridge
 - external label 237
- IBM 3590 High Performance Tape Cartridge
 - 3M Corporation 37
 - cartridge type 37
 - casing 37
 - characteristics 36
 - cleaner cartridge 37
 - density 13
 - design 36
 - media type 37
 - medium 13
 - metal particle medium 37
 - servo track 38
 - tape space utilization 20
- IBM 3590 High Performance Tape Subsystem
 - ACF 6
 - automation 10
 - configuration 65
 - design targets 9
 - hardware description 23
 - helical scan 12
 - history 4
 - IBM 3495 7
 - IBM 3495 Model M10 Manual Tape Library Dataserver 7, 32
 - IBM 3590-A00 7
 - IBM 3590-A14 7
 - IBM 3590-B11 7
 - IBM 3590-B1A 7
 - IBM 3590-C12 7
 - IBMLZ1 7
 - introduction 1
 - longitudinal technology 12

- IBM 3590 High Performance Tape Subsystem
 - (*continued*)
 - marketing requirements 9
 - metal particle medium 6
 - objectives 11
 - OEMI (parallel) channel 30
 - options 12
 - performance considerations 131
 - software support 93
 - technology 11
- IBM 3590 support
 - AIX/6000 123
 - BCP 101
 - BTLS 104
 - CMS 120
 - DDR 120
 - DFSMS/MVS 104
 - DFSMS/VM RMS 120
 - guest operating system 119
 - JES3 117
 - MVS/ESA 101
 - OS/400 122
 - Solaris 125
 - SPE 101
 - SPXTAPE 120
 - SunOS 125
 - TPF 121
 - VM/ESA 119
 - VSE/ESA 121
- IBM 3590 tape subsystem
 - Silo 213, 217
 - StorageTek Automated Cartridge System 213
- IBM 3590-A00 7, 30
 - ESCON 30
 - IBM 3590-A14 31
 - IBM 3590-B11 31
 - IBM 3590-B1A 31
 - Library Manager 30
 - logical path 7, 31
 - tape controller 7
 - Virtual Tape Server configuration 160
- IBM 3590-A14 7, 28, 32
 - ES/9000 and S/390 configuration 66
 - IBM 3495 Automated Tape Library Dataserver 32
 - IBM 3590-A00 31, 32
 - IBM 3590-A14 7
 - IBM 3590-B11 32
 - operator display 32
 - Virtual Tape Server configuration 161, 173
- IBM 3590-B11 7
 - IBM 3590-A00 31
- IBM 3590-B1A 7
 - cleaning program 234
 - Feature 2003 223
 - Feature 9000 223
 - features 223
 - IBM 3590-A00 31
 - IBM 3590-C12 220
- IBM 3590-B1A (*continued*)
 - Virtual Tape Server configuration 160, 161
- IBM 3590-C12 7
 - display 221
 - external label 222, 237
 - Feature 520x 222
 - Feature 8002 222
 - Feature 8210 222
 - Feature 8220 222
 - Feature 9590 222
 - Feature 9986 223
 - features 222
 - IBM 3590-B1A 220
 - IBM 3590-C12 7
 - IBM 3591-A01 220
 - installation 233
 - physical characteristics 221
 - PTF 233
 - sample cleaning program 241
 - SCSI cable 222
 - Silo 216, 217, 218
 - Silo-compatible frame 220
 - StorageTek Automated Cartridge System 218
 - Texas Digital Systems, Inc. (TDS) 221
- IBM 3591 tape subsystem
 - sample cleaning program 241
- IBM 3591-A01
 - ESCON adapter 226
 - Feature 2700 226
 - Feature 2701 226
 - Feature 2702 226
 - Feature 3311 226
 - Feature 5000 226
 - features 226
 - IBM 3590-C12 220, 224
 - logical path 7, 224
 - physical characteristics 225
 - software support 225
 - tape controller 7
- IBM 3850 Mass Storage System (MSS) 5
- IBM 7202 7, 28, 75
- IBM 7206 19
- IBM 7207 19
- IBM 7208 19
- IBM 726 3
- IBM 727 2
- IBM 729 2
- IBM 7331 19, 123
- IBM 7332 19
- IBM 9309 7, 28, 73, 75
- IBM Client Input Output/Sockets
 - See CLIO/S
- IBM Magstar Virtual Tape Server (VTS)
 - IBM 3494 Automated Tape Library Dataserver Configuration 78
 - IBM 3495 Automated Tape Library Dataserver 70
 - IBM Magstar Virtual Tape Server (VTS) 7
 - Virtual Tape Server 7

IBM Magstar Virtual Tape Server (VTS) *(continued)*
 Virtual Tape Server subsystem 7

IBM tape products
 automation 19
 capacity 18
 performance 18
 reliability 19

IBMLZ1 143, 144, 145

ICL 39
 IBM 3490 40

IDRC 3, 25, 133, 143, 144
 logical volume 154
 virtual volume 189

IECIOSxx
 SYS1.PARMLIB member 102

IEHINITT
 Virtual Tape Server 181

IFHSTATR 103

IGE0003E
 ERP 105

import position 46, 99

Improved Data Recording Capability
 See IDRC

initialization parameter
 JES3 117

installation
 Host Software Component 235
 IBM 3590-C12 233

installation tasks
 Virtual Tape Server 197

integrated cartridge loader
 See ICL

Interactive Storage Management Facility
 See ISMF

interleaved
 recording 14
 track sets 15

interposer
 Feature 9701 76
 Feature 9702 76

inventories and catalog
 Silo 237

inventory
 Virtual Tape Server 197

IOCP
 virtual device 157
 Virtual Tape Server 157

IPL Read CCW 97

ISMF 109

J

JES3 94, 101
 DJ 118
 IBM 3590 support 117
 initialization parameter 117
 library device group name 117
 tape DSP 118
 Virtual Tape Server 163

JUNIT
 IBM 3590 117

L

LCD 40
 operator panel 40

LCS 113
 external services 114
 OAM tape library support routines 113

LDG 117

library control system
 See LCS

library device group
 See LDG

library device group name
 JES3 117

LIBRARY DISPCL operator command
 tape library support 116

LIBRARY DISPDRV operator command
 tape library support 116

Library Manager
 AS/400 74
 device driver 123, 125
 displayed information 208
 ES/9000 and S/390 configuration 68
 IBM 3495 Automated Tape Library Dataserver 70
 IBM 3590-A00 30
 logical volume 158
 RISC/6000 76
 RS-422 70
 SMF record type 94 207
 statistics 207
 Virtual Tape Server 195

Library Manager attachment
 IBM 3494-B16 165
 IBM 3494-D12 165
 IBM 3495 174
 RS-232 166
 RS-422 165
 Virtual Tape Server 165, 174

LIBRARY SETCL operator command
 tape library support 116

liquid crystal display
 See LCD

Load Display command
 Virtual Tape Server 205

load order
 ACF 98

logging
 Virtual Tape Server 206
 virtual volume 207

logical block number 100, 105

logical partitioning
 Virtual Tape Server 197

logical path 67
 IBM 3590-A00 7, 31
 IBM 3591-A01 7, 224

- logical volume
 - concept 158
 - CST 154
 - data invalidation 182
 - definition 198
 - ECCST 154
 - Fast-Ready attribute 158, 182
 - IDRC 154
 - Library Manager 158
 - MEDIA1 154
 - MEDIA2 154
 - space reclamation 186
 - tape volume cache 158
 - Virtual Tape Server 154
 - virtual volume 158
- longitudinal recording
 - data integrity 17
 - head wear 17
 - horizontal damage 14
 - interleaved 14
 - media wear 17
 - reason for using 17
 - recording 5
 - start-stop operation 17
 - technology 12
 - vertical damage 14
- LZ
 - IBM 3590 7, 25
- LZ1 25
- LZ2 145

M

- magazine
 - ACF 41, 46
 - latch lock 47
 - locking bar 47
- magneto resistive (MR) heads 15
- Magstar
 - compression 25
 - control unit function 25
 - data rate 25
 - drive models 28
 - drive unit 24
 - IBM 3590-B11 7
 - IBM 3590-B1A 7
 - introduction 1
 - operating characteristics 24
 - performance considerations 131
 - schematic comparison 27
 - SCSI attachment 24
- manual mode
 - ACF 48, 51
 - disabling conditions 52
 - operational flow 51
- marketing requirements
 - IBM 3590 High Performance Tape Subsystem 9
- Mass Storage System
 - See MSS

- media
 - IBM 3490E 19
 - IBM 3590 19
 - IBM 7206 19
 - IBM 7207 19
 - IBM 7208 19
 - IBM 7331 19
 - IBM 7332 19
- media information message
 - See MIM
- media type
 - CST 37
 - ECCST 37
 - IBM 3494 37
 - IBM 3495 37
 - IBM 3590 High Performance Tape Cartridge 37
- media wear
 - longitudinal recording 17
- MEDIA1
 - logical volume 154
- MEDIA2
 - logical volume 154
- MEDIA3
 - ALTER AMS command 108
 - CREATE AMS command 108
 - data class 107
 - dynamic allocation 103
- MEDIATYP
 - TCDB 113
- medium
 - chromium dioxide 13
 - IBM 3590 High Performance Tape Cartridge 13
 - metal particle 13
- Medium Mover command
 - Move Medium 59
 - Prevent Medium Removal 59
 - Read Element Status 59
 - SCSI 49, 59, 60
- menu area
 - operator panel screen 44
- menu control switch 43
- message
 - FID 45
- metal particle medium 13, 19
 - IBM 3590 High Performance Tape Cartridge 37
 - IBM 3590 High Performance Tape Subsystem 6
- migration
 - IBM 3590 238
 - native 3490E 204
 - Silo 238
 - Virtual Tape Server 203
- MIH 102
- MIM 103
- missing interrupt handler
 - See MIH
- mixed configuration
 - IBM 3494 Automated Tape Library Dataserver 80
 - IBM 3495 Automated Tape Library Dataserver 71

- mode switch 42
- model upgrade
 - IBM 3494-L10 83
- model upgrades
 - IBM 3494 171
- modem
 - Remote Support Facility 168, 174
- MONITOR CP command
 - IBM 3590 support 120
- monitoring
 - Virtual Tape Server 206
- mount response time
 - virtual volume 189
- move order 99
 - ACF 99
- MSS 5
- MVS/DFP
 - Virtual Tape Server 163
- MVS/ESA 94
 - BCP 101
 - BTLS 201
 - DFSMS system-managed tape 200
 - IBM 3590 support 101
 - SPE 101
 - stand-alone dump program 101
 - Virtual Tape Server 163, 200
- MVSCP 101

N

- native data rate
 - IBM 3490E 132
- non-DFSMS
 - supported configurations 91
- nonspecific mount
 - Virtual Tape Server 181
- NOTE macro 105
- NSL UniTree 95, 129

O

- OAM 112
- object access method
 - See OAM
- object tape support 112
- OEMI channel
 - IBM 3590 High Performance Tape Subsystem 30
- OPEN/CLOSE/EOV
 - IBM 3590 106
- operation
 - ACF 39
 - Automated Cartridge System 236
 - drive cleaning 236
 - Silo 236
- operational flow
 - accumulate mode 53, 56
 - manual mode 51
 - random mode 60
 - system mode 58

- operator command
 - tape library support 115
- operator display
 - IBM 3590-A14 32
 - Texas Digital Systems, Inc. 32
- operator panel
 - ACF 40
 - IBM 3590 42
 - LCD 40
 - menu control switch 43
 - mode switch 42
 - power-on reset 42
 - reset switch 42
- operator panel screen
 - IBM 3590 44
 - Intervention Screen 45
 - menu area 44
 - Option/Status Screen 44
 - status area 44
 - UNLOAD 44
- optical configuration database 112
- OS/400 95
 - IBM 3590 support 122
 - software distribution 122
 - supported configurations 91

P

- panel
 - ISMF 109
- parallel channel
 - IBM 3590 High Performance Tape Subsystem 30
- partitioning
 - Library Manager 195
 - Virtual Tape Server 195
- performance
 - IBM tape products 18
- performance considerations
 - DASD data rate 145
 - IBM 3590 High Performance Tape Subsystem 131
 - Magstar 131
- physical characteristics
 - IBM 3591-A01 225
- physical device
 - concept 159
 - Virtual Tape Server 159
- physical installation
 - Virtual Tape Server 197
- physical volume
 - compression 189
 - concept 158
 - definition 199
 - error recovery 211
 - space reclamation 186
 - Virtual Tape Server 158, 199
- power consumption 34
- power control 34
- power-on reset 42

POWERparallel SP2
 AIX/6000 123
 configuration 75, 77
 IBM 3494 Automated Tape Library Dataserver 75
 supported configurations 91
priority cell
 ACF 40
PTF
 IBM 3590-C12 233

Q

QUIETIS 194

R

R/DARS for OS/400 95
rack
 EIA 75
 IBM 7202 7, 75
 IBM 9309 7, 73, 75
RAID
 Tape Volume Cache 151
random access
 virtual volume 190
random mode
 ACF 6, 49, 59
 DFSMS/MVS 50, 59, 99, 104
 disabling conditions 61
 operational flow 60
 OS/400 122
 SCSI Medium Mover command 49, 59, 60
 Stage CCW 49, 59, 60, 99
RAR 105
RDTAPE
 CMS macro 120
read alternate recovery
 See RAR
Read Backward CCW 97
 Checkpoint/Restart 106
 ERP 105
 SAM 106
Read Block ID CCW 97
Read Buffer command
 Virtual Tape Server 205
Read Buffered Log CCW 97
read cell status order 99
 ACF 99
Read Configuration Data CCW 97, 102
Read Device Characteristics CCW 97
Read Forward CCW 97
 CP 119
 SAM 105
Read IPL CCW
 CP 119
Read Media Characteristics CCW 97
Read Opposite Recovery
 See ROR

Read Previous CCW 97
 Checkpoint/Restart 106
 ERP 105
read volume loader data order 99
 ACF 99
read/write tape speed 24
recording
 helical scan 5
 longitudinal 5
Redundant Array of Inexpensive Disk
 See RAID
REELlibrarian 95, 129
reformatting
 servo track 38
reliability
 IBM tape products 19
Remote Support Facility
 See RSF
Remote Tape Application Interface
 See RTAPI
Removable Media Manager 3, 110
Removable Media Services
 See RMS
Report/Data Archive and Retrieval System
 See R/DARS for OS/400
reset switch 42
rewind speed 24
rewind time 24
RISC/6000
 AIX/6000 123
 block size 76
 configuration 75
 Feature 2416 76
 Feature 2420 76
 IBM 3494 Automated Tape Library Dataserver 75
 Library Manager 76
 SCSI consideration 76
 SCSI-2 Differential Fast/Wide Adapter/A 76
 SCSI-2 Differential High-Performance External I/O
 Controller 76
 special feature 76
 supported configurations 91
RMM TSO subcommand 110
RMS 120
ROR 105
RPQ
 843860 122
 8B3166 84
 8B3167 84
 8B3168 84
RS-232
 Library Manager attachment 166
 Virtual Tape Server 166
RS-422
 Library Manager attachment 165
 Virtual Tape Server 165
RSF
 IBM 3494-B16 168

RSF (*continued*)

- IBM 3495-B16 174
- IBM 3591-A01 226
- modem 168, 174
- RTAPI 95, 128

S

- S/390 parallel server
 - IBM 3494 Automated Tape Library Dataserver 66
 - IBM 3495 Automated Tape Library Dataserver 67
 - IBM 3495 Model M10 Manual Tape Library Dataserver 67
 - IBM 3590-A14 66
 - Library Manager 68
 - software support 94
 - supported configurations 91
- SADMP 101
- SAM 105
- scratch mount
 - Fast-Ready attribute 199
 - Virtual Tape Server 181
- SCSI 7
 - AS/400 74
 - attachment 24
 - command 96
 - IBM 3490E data rate 137
 - IBM 3490E data rate chart 138
 - IBM 3590 data rate 140
 - IBM 3590 data rate chart 141
 - Medium Mover command 49, 59, 60
 - RISC/6000 76
 - Sun SCSI Differential Ended Adapter 77
- SCSI cable
 - IBM 3590-C12 222
- SCSI-2 Differential Fast/Wide Adapter/A 76
- SCSI-2 Differential High-Performance External I/O Controller 76
- SCSI-3 25
- sequential access method
 - See SAM
- Serial Storage Architecture
 - See SSA
- service aids
 - device driver 124, 125
- service information message
 - See SIM
- servo track 16
 - degaussing 38
 - IBM 3590 High Performance Tape Cartridge 38
 - reformatting 38
- SETNAME
 - IBM 3590 117
- SETOAM command 113
- sharing
 - IBM 3494 Automated Tape Library Dataserver 81
 - TCDB 116
- Silo
 - 4410 Automated Cartridge System 214

Silo (*continued*)

- 9310 PowderHore Automated Cartridge System 214
 - cleaning program 234
 - configuration 218
 - device combination 227
 - drive cleaning 236
 - ESCON director 219
 - external label 237
 - Host Software Component 214, 219
 - IBM 3490E 216
 - IBM 3590 tape subsystem 213, 217
 - IBM 3590-C12 216, 217, 218, 220
 - IBM 3591-A01 219
 - inventories and catalog 237
 - Library Control Unit 215, 218
 - Library Management Unit 215, 219
 - Library Storage Module 215, 218
 - migration 238
 - Network Controller 219
 - operation 236
 - PowderHore 214
 - scratch allocation 229
 - specific allocation 231
 - Virtual Tape Server 239
- SIM 102, 103
- sizing
 - guidelines 191
 - tools 193
 - Virtual Tape Server 191, 193
- small computer system interface
 - See SCSI
- small programming enhancement
 - See SPE
- SMF
 - Error Statistics by Volume 103
 - IFHSTATR 103
 - type 21 103
- SMF record type 94
 - Library Manager statistics 207
 - Virtual Tape Server operational information 208
- SMS 107
 - ACS routine 108
 - data class 107
 - storage group 108
- SMT 107
- software distribution
 - IBM 3590 122
- software implementation
 - BTLS 201
 - DFSMS system-managed tape 200
 - MVS/ESA 200
 - VM/ESA 201
 - VSE/ESA 201
- software support
 - ES/9000 94
 - IBM 3590 High Performance Tape Subsystem 93
 - IBM 3591-A01 225

- software support (*continued*)
 - matrix 91
 - MVS/ESA 94
 - OS/400 95
 - overview 94
 - POWERparallel SP2 95
 - RISC/6000 95
 - S/390 Parallel Server 94
 - Sun systems 95
 - TPF 95
 - Virtual Tape Server 163
 - VM/ESA 95
 - VSE/ESA 95
- Solaris 95
 - ADSM 127
 - IBM 3590 support 125
 - supported configurations 91
- space reclamation
 - logical volume 186
 - physical volume 186
 - schedule 199
 - Tape Volume Cache 185
 - Virtual Tape Server 185, 199
- SPE 101
 - IBM 3590 support 104
- special feature
 - AS/400 74
 - RISC/6000 76
- specific mount
 - Virtual Tape Server 184
- SPXTAPE
 - IBM 3590 support 120
- SSA
 - Virtual Tape Server 152
- stacked volume
 - concept 158
 - Virtual Tape Server 158
- Stage CCW
 - load order 98
 - move order 99
 - random mode 49, 59, 60, 99
 - read cell status order 99
 - read volume loader data order 99
 - unload order 98
- stand-alone dump program
 - See also* SADMP
 - MVS/ESA 101
 - VM/ESA 120
- start-stop operation
 - longitudinal recording 17
- statistics
 - Library Manager 207
 - SMF record type 94 207
 - Virtual Tape Server 206
- status area
 - operator panel screen 44
- status light
 - ACF 41
- storage capacity
 - Virtual Tape Server 155
- storage cell
 - IBM 3495 174
 - Virtual Tape Server 174
- storage class
 - scratch allocation 229
- storage group
 - scratch allocation 229
 - SMS 108
- storage unit frame
 - IBM 3494 Automated Tape Library Dataserver 78
 - IBM 3494-S10 83
- StorageTek 215
 - 4410 Automated Cartridge System 214
 - 4480 Cartridge Tape Subsystem 214
 - 4480 tape drive 227
 - 4490 tape drive 227
 - 9310 PowderHore Automated Cartridge System 214
 - 9490 tape drive 227
 - Host Software Component 214, 219
 - Library Control Unit 215
 - Library Management Unit 215, 219
 - Library Storage Module 215
 - Nearline 214
 - PowderHore 214
 - RedWood SD-3 Helical Cartridge Tape Subsystem 215
 - Silo 214, 215
 - Silverton 4490 Cartridge Subsystem 215
 - Timberline 9490 Cartridge Tape Subsystem 215
- StorageTek Automated Cartridge System
 - configuration 218
 - ESCON director 219
 - Host Software Component 219
 - IBM 3590 tape subsystem 213
 - IBM 3590-C12 218
 - IBM 3591-A01 219
 - Library Control Unit 218
 - Library Management Unit 219
 - Library Storage Module 218
 - Network Controller 219
- stub
 - Virtual Tape Server 181
 - virtual volume 181
- Sun systems
 - block size 77, 126
 - configuration 77
 - SCSI Differential Ended Adapter 77
 - supported configurations 91
- SunOS 95
 - ADSM 127
 - IBM 3590 support 125
 - supported configurations 91
- SVC 99 103
- SYNADAF macro 105

- SYS1.PARMLIB member
 - CBROAMxx 113
 - IECIOSxx 102
- System Managed Tape
 - See SMT
- system mode
 - ACF 49, 57
 - disabling conditions 58
 - operational flow 58
- System-Managed Storage
 - See SMS

T

- TAPE
 - CMS command 120
- tape cartridge
 - CST 36
 - ECCST 36
 - IBM 3590 High Performance Tape Cartridge 36
- tape command
 - AIX/6000 124
- tape configuration database
 - See TCDB
- tape control operation 31
- tape control unit
 - IBM 3590-A00 30
- tape controller
 - IBM 3590-A00 7
 - IBM 3591-A01 7
- Tape Data Set Analysis
 - See TDSA
- tape device selection information
 - See TDSI
- tape label
 - initialize 181
 - Virtual Tape Server 157, 181
- tape library
 - scratch allocation 229
- tape library support
 - installation exit 115
 - operator command 115
 - TCDB 113
- Tape Mount Management
 - See TMM
- tape positioning commands
 - virtual volume 190
- tape space utilization
 - ADSM 20
 - BRMS/400 20
 - DFSMSHsm 20
 - IBM 3590 High Performance Tape Cartridge 20
- tape technology
 - first generation 3
 - history 2
 - second generation 3
 - third generation 4
- Tape Volume Cache
 - See TVC

- TAPECTL
 - CMS macro 120
- TAPESL
 - CMS macro 120
- TCDB 113
 - sharing 116
 - specific allocation 231
- TDSA 194
- TDSI 114
- teach
 - Virtual Tape Server 197
- Texas Digital Systems, Inc.
 - IBM 3590-A14 32
 - operator display 32
- Texas Digital Systems, Inc. (TDS)
 - display 221
 - IBM 3590-C12 221
- TMM 4
- toleration PTF
 - DFSMS/MVS 94, 104
 - tape library support 113
- tools
 - DASD and Tape Magic for OS/2 194
 - Quick and easy tape investigation and simulation
 - See QUIETIS
 - Volume Mount Analyzer
 - See VMA
- TPF 95
 - IBM 3590 support 121
- track sets
 - IBM 3480 15
 - IBM 3490 15
 - IBM 3490E 15
 - IBM 3590 15
- Transaction Processing Facility
 - See TPF
- transport mechanism
 - ACF 41
- TRSAVE CP command
 - IBM 3590 support 120
- TVC
 - IBM 3494 154
 - IBM 3495 155
 - logical volume 158
 - RAID 151
 - space reclamation 185
 - Virtual Tape Server 184
 - virtual volume 151

U

- UCB 102, 103
- UCBTYPE 102
- unit name
 - 3590-1 102
- UNITNAME
 - TCDB 113
- UNLOAD
 - operator panel screen 44

unload order
ACF 98

V

vaulting
Virtual Tape Server 210

virtual device
characteristics 157
coexistence 195
concept 157
definition 157
HCD 157
IBM 3490E 195
IOCP 157
Virtual Tape Server 157

Virtual Tape Server
See VTS

virtual volume
advantage 189
capacity 189
characteristics 157
compression 188
concept 157
CST 189
ECCST 189
event logging 207
IDRC 189
logical volume 158
mount response time 189
random access 190
stub 181
tape positioning commands 190
Tape Volume Cache 151, 184

VM/ESA 95
IBM 3590 support 119
stand-alone dump 120
supported configurations 91
Virtual Tape Server 164, 201

VM/VSE or VGS
supported configurations 91

VMA 193

VMFPLC2
CMS command 120

voltage 34

volume audit processing 116

volume not in library exit
CBRUXVNL 115

volume not in library installation exit processing 116

volume serial
definition 198
logical volume 198
physical volume 199
Virtual Tape Server 183, 198

VSE/ESA 95
IBM 3590 support 121
supported configurations 91
Virtual Tape Server 164, 201

VTS

announce 21, 148
block ID 205
BTLS 163
channel attachment 151
coexistence 151
compaction ratio 205
configuration 154
configuration guidelines 167, 173
controller 150
CST 154
data invalidation 182
Data Security Erase command 205
DDR 204
DFSMS/MVS 163
DFSMS/VM 164
dimension 172, 179
ECCST 154
EDGINERS 181
environmentals 172, 179
Erase Gap command 205
EREP 163, 164
error recovery 211
ESCON channel 165
event logging 206
Fast-Ready attribute 182
features 169, 177
frame replacement 175
HCD 157, 198
IBM 3494 21, 148, 150, 151, 160
IBM 3494 Automated Tape Library Dataserver 80
IBM 3494-B16 21, 80, 148, 161
IBM 3494-D10 161
IBM 3494-D12 161
IBM 3494-D14 161
IBM 3494-S10 161
IBM 3495 72, 151, 161
IBM 3495-B16 22, 149, 173
IBM 3590 21, 148, 151
IBM 3590-A14 173
IDRC 154
IEHINITT 181
installation tasks 197
introduction 150
inventory 197
IOCP 157
JES3 163
key attributes 153
key concepts 156
Library Manager attachment 165
Load Display command 205
logging 206
logical data flow 180
logical partitioning 197
logical tape drive 153
logical volume 154, 158
MEDIA1 154
MEDIA2 154

VTS (*continued*)

- migration 203
 - monitoring 206
 - MVS/DFP 163
 - MVS/ESA 163
 - nonspecific mount 181
 - operational considerations 210
 - operational information 208
 - operational statistics 206
 - partitioning 195
 - physical device 159
 - physical installation 195, 197
 - physical tape drive 153
 - physical volume 158
 - positioning beyond EOD 205
 - Read Buffer command 205
 - scratch mount 181
 - Serial Storage Architecture 152
 - Silo 239
 - sizing 193
 - sizing guidelines 191
 - software implementation 200
 - software support 163
 - software transparency 150
 - space reclamation 185
 - specific mount 184
 - stacked volume 158
 - storage capacity 155
 - storage cell 174
 - storage management 152
 - stub 181
 - tape label 157, 181
 - Tape Volume Cache 151
 - teach 197
 - technology 151
 - vaulting 210
 - virtual device 157
 - virtual volume 157
 - VM/ESA 164
 - volume serial 183, 198
 - VSE/ESA 164
- VTS unit frame
- IBM 3494-B16 83
 - IBM 3494-D12 83
- VTS.
- IBM 3495 72

Z

- Ziv-Lempel
- See LZ

W

- WRTAPE
- CMS macro 120

X

- XDF 67



Printed in U.S.A.

SG24-2506-01

