



.....

***DAT 72 and DDS-4 Tape Drives***

.....

***CD72LWH***

.....

***CD72LWE***

.....

***STD1401LW***

.....

***STD2401LW***

.....

***STD6401LW***

.....

***Product Manual***

.....

Copyright © 2003 by Certance LLC. All Rights Reserved..

Part Number: 50000712, June 2003

Certance and the Certance logo are trademarks of Certance LLC. Seagate is a trademark of Seagate Technology LLC. Other product names are trademarks or registered trademarks of their respective owners.

Certance reserves the right to change, without notice, product offerings or specifications. No part of this publication may be reproduced in any form without written permission from Certance LLC.

Certance provides this manual "as is," without warranty of any kind, either expressed or implied, including, but not limited to, the implied warranties of merchantability and fitness for a particular purpose. Certance reserves the right to change, without notification, the specifications contained in this manual.

Certance assumes no responsibility for the accuracy, completeness, sufficiency, or usefulness of this manual, nor for any problem that might arise from the use of the information in this manual.

## FCC Notice

This equipment generates and uses radio frequency energy and, if not installed and used properly—that is, in strict accordance with the manufacturer's instructions—may cause interference to radio communications or radio and television reception. It has been tested and found to comply with the limits for a Class B computing device in accordance with the specifications in Part 15 of FCC Rules, which are designed to provide reasonable protection against such interference in a residential installation. However, there is no guarantee that interference will not occur in a particular installation. If this equipment does cause interference to radio or television reception, which can be determined by turning the equipment on and off, you are encouraged to try to correct the interference by one or more of the following measures:

- Reorient the receiving antenna.
- Relocate the computer with respect to the receiver.
- Move the computer into a different outlet so that the computer and receiver are on different branch circuits.

If necessary, you should consult the dealer or an experienced radio/television technician for additional suggestions. You may find the booklet, *How to Identify and Resolve Radio-TV Interference Problems*, prepared by the Federal Communications Commission, helpful. This booklet (Stock No. 004-000-00345-4) is available from the U.S. Government Printing Office, Washington, DC 20402.

<p><b>Warning.</b> Changes or modifications made to this equipment which have not been expressly approved by Seagate may cause radio and television interference problems that could void the user's authority to operate the equipment.</p>
--

Further, this equipment complies with the limits for a Class B digital apparatus in accordance with Canadian Radio Interference Regulations.

Cet appareil numérique de la classe B est conforme au Règlement sur brouillage radioélectrique, C. R. C., ch. 1374.

The external device drive described in this manual requires shielded interface cables to comply with FCC emission limits.

### **Additional Warnings:**

- To prevent fire or electrical shock hazard, do not expose the unit to rain or moisture.
- To avoid electrical shock, do not open the cabinet.
- Refer servicing to qualified personnel.

## About This Manual

This is the product manual for DAT 72 and DDS-4 internal and external tape drives. It describes how to use the DAT 72 and DDS-4 drives.

Following are brief descriptions of the sections in this manual.

Chapter 1, "Introduction" provides general specifications, features and an overview on DDS technology.

Chapter 2, "Specifications" contains physical, performance, environmental, reliability, and power specifications.

Chapter 3, "Installation" provides cautions, unpacking tips, inspection information and installation/connection steps.

Chapter 4, "Drive Operation and Maintenance" explains the operation of the drive and describes necessary maintenance procedures.

Chapter 5, "Theory of Operations" details the functional operation of various assemblies of the drive.

Chapter 6, "Data Compression" describes the data compression algorithm and explains pertinent information for effective use of data compression.

# Contents

---

<b>Introduction</b>	<b>1</b>
Overview.....	1
DDS Format Standard Compatibility .....	1
DAT 72 and DDS-4 Capacity and Transfer Rates .....	2
Features .....	3
DAT 72 and DDS-4 Drive Models.....	4
<b>Specifications</b>	<b>7</b>
Overview.....	7
Physical Specifications .....	7
Power Specifications .....	9
Drive Performance Specifications .....	10
Environmental Requirements .....	12
Reliability .....	12
Mean Time Between Failures .....	13
Mean Time to Repair.....	13
DDS Cartridge Specifications .....	13
Regulatory Compliance .....	14
<b>Installation</b>	<b>15</b>
Introduction.....	15
Unpacking and Inspection .....	15
Installing an Internal Drive .....	15
Guidelines and Cautions .....	16
Configuring an Internal Drive .....	16
DIP Switch Settings.....	18
Mounting an Internal Drive .....	20
Installing an External Drive .....	24
Configuring the External Drive .....	24
Connecting the SCSI Interface Cable .....	25
Connecting the Power Cord.....	25
<b>Drive Operation and Maintenance</b>	<b>27</b>
Loading a Cartridge .....	27

Unloading a Cartridge .....	27
Initializing a Blank Cartridge .....	28
DDS Cartridge Compatibility .....	28
Write-Protecting a Cartridge .....	28
LED Codes.....	29
Clean LED .....	30
Media LED.....	30
Drive LED .....	30
LED Code Summary .....	31
Cleaning the Tape Heads .....	31
When to Clean the Tape Heads .....	31
How to Clean the Tape Heads .....	32
Automatic Drive Spin-Down and Write.....	32
Operating the Drive in High-Temperature or Humidity Conditions .....	32
Data Compression .....	33
Loading Revised Firmware from Seagate Firmware Cartridges.....	33
Flash Memory.....	33
Firmware Download Process via Tape .....	33

---

## **Theory of Operations 35**

Overview .....	35
Drive Mechanism.....	35
Motors and Control Circuits .....	38
Timing Tracking Circuitry.....	38
Signal-Processing Electronics.....	38
Flash Memory .....	38
Sensors.....	39
Read-After-Write .....	39
Media Recognition System (MRS).....	40
About the DDS Data Cartridge.....	40

---

## **Data Compression 43**

Introduction .....	43
Overview .....	43
Data Compression Considerations.....	44
Hardware Compression.....	45
Data Integrity .....	45
DCLZ Algorithm .....	46
Simplified Compression Operation.....	46
Dictionary .....	47

Simplified Decompression Operation.....	48
---	----

## Figures

Figure 1. 3.5-Inch Internal Drive .....	4
Figure 2. Internal Drive with Drive Rails for Mounting in a 5.25-inch Drive Bay .....	4
Figure 3. External Drive .....	5
Figure 4. Internal Drive—Dimensions .....	8
Figure 5. Internal DDS Drive with Rails—Dimensions .....	8
Figure 6. Jumper Settings for an Internal Drive .....	17
Figure 7. DIP Switch Settings for an Internal Drive.....	18
Figure 8. Mounting an Internal Drive.....	20
Figure 9. Mounting Holes for an Internal Drive in a 3.5-inch Configuration (without mounting brackets).....	20
Figure 10. Mounting Holes for an Internal Drive in a 5.25-inch Configuration (with mounting brackets).....	21
Figure 11. Interface Connector on an Internal Drive.....	22
Figure 12. Two SCSI Termination Examples for Internal Drives .....	22
Figure 13. Power Connector on the internal Drives.....	23
Figure 14. Rear Panel of External Drives .....	24
Figure 15. SCSI Termination Examples for External Drives.....	25
Figure 16. Loading a Tape Cartridge.....	27
Figure 17. Location of the Eject Button and LEDs on internal Drives (external drive is similar).....	28
Figure 18. Write-Protect Tab on a DDS Cartridge .....	29
Figure 19. Front Panel of an Internal Drive (external drive is similar).....	29
Figure 20. Four-Head Cylinder Design .....	37
Figure 21. Alternating Azimuth Angles on Tape Tracks.....	37
Figure 22. DDS Drive Cartridge Design Features.....	41
Figure 23. Write-Protect Tab on the DDS Cartridge .....	41



# Introduction

# 1

## Overview

The Seagate® DDS-4 (digital data storage) and DAT 72 (digital audio tape) drives are designed for computer environments that require high-performance, high-capacity data storage. Based on a 3.5-inch mechanism, the internal and external models provide the following data storage capacities and native transfer rates:

	<i>DDS-4</i>	<i>DAT 72</i>
Data Storage Capacity:	20 Gbytes (40 Gbytes compressed)	36 Gbytes (72 Gbytes compressed)
Native Transfer Rate:	2.75 Mbytes per second (5.5 Mbytes per second compressed)	3.5 Mbytes per second (7.0 Mbytes per second compressed)

The DAT 72 and DDS-4 drives combine established DAT technology, high-density recording and hardware data-compression capability along with Seagate's proven computer-grade design to provide unmatched reliability and performance characteristics among DDS products. The DAT 72 and DDS-4 drives are ideal for workstation, server, and network/enterprise applications such as:

- Backup of high-capacity fixed discs
- Data interchange between systems
- Network servers
- Loader products
- Online data collection
- Near-line secondary storage for text, graphics or multimedia information of all types
- Archival storage

### **DDS Format Standard Compatibility**

The DDS drive supports the DDS-4, DDS-3, and DDS-2 recording formats. The DAT 72 drive supports the DDS 5<sup>th</sup> Generation, DDS-4, and DDS-3 recording formats. Compatibility with each of these standards ensures complete write and read interchange of recorded digital data between all compliant drive and media vendors.

The DAT 72 and DDS-4 drives support DDS data compression. Compression doubles a drive's uncompressed capacity. For example, a 20 GB uncompressed drive will be 40 GB with compression.

The DDS-4 drive complies with the following guidelines and specifications:

- The DDS-2 recording format standard, ANSI/ECMA-198, *3,81mm Wide Magnetic Tape Cartridge for Information Interchange - Helical Scan Recording - DDS-2 Format using 120 m Length Tapes*
- The DDS-3 recording format standard, ANSI/ECMA-236, *3,81mm Wide Magnetic Tape Cartridge for Information Interchange - Helical Scan Recording - DDS-3 Format using 125 m Length Tapes*
- The DDS-4 recording format specification from ECMA-288: *3,81 mm Wide Magnetic Tape Cartridge for Information Interchange - Helical Scan Recording: DDS-4 Format*

The DAT 72 drive complies with the following guidelines and specifications:

- The DDS-3 recording format standard, ANSI/ECMA-236, *3,81mm Wide Magnetic Tape Cartridge for Information Interchange - Helical Scan Recording - DDS-3 Format using 125 m Length Tapes*
- The DDS-4 recording format specification from ECMA-288: *3,81 mm Wide Magnetic Tape Cartridge for Information Interchange - Helical Scan Recording: DDS-4 Format*
- The DDS 5th Generation recording format specification from the HP DAT 72 Format Standard A5969-3050-1: *3,81 mm Wide Magnetic Tape Cartridge for Information Interchange - Helical Scan Recording - DAT 72 Format Using 170 m Length Tapes.*

**Note:** For the latest ECMA standards, see the ECMA web site at <http://www.ecma.ch>

### ***DAT 72 and DDS-4 Capacity and Transfer Rates***

The DAT 72 and DDS-4 drives provide the following capacities and transfer rates, depending on the recording mode and the tape length:

	<b>Recording Mode</b>			
	<b>DDS-2*</b>	<b>DDS-3</b>	<b>DDS-4</b>	<b>DDS 5<sup>th</sup> Generation</b>
Tape length	120 meters	125 meters	150 meters	170 meters
Capacity (native)	4.0 Gbytes	12.0 Gbytes	20.0 Gbytes	36.0 Gbytes
Capacity (compressed)	8 Gbytes	24 Gbytes	40 Gbytes	72 Gbytes
Transfer rate (native)	1.375 Mbytes/sec	2.75 Mbytes/sec	2.75 Mbytes/sec	3.54 Mbytes/sec
* Applies to the DDS-4 drive only.				

In data-compression mode, the Seagate DAT 72 and DDS-4 drives typically double the storage capacity and transfer rate of the native uncompressed operation. Tape capacity and the sustained data-transfer rate are dependent upon the characteristics of the files being compressed, the application software used, and system parameters such as the speed of the host and the operating system. The DAT 72 and DDS-4 drives also offer synchronous or asynchronous SCSI transfers with a high-speed burst data-transfer rates.

The DAT 72 and DDS-4 drives provide superb reliability through three levels of error-correction code (ECC) and the four-head design, which provides for read-after-write (RAW) error detection and correction. The DAT 72 and DDS-4 drives also include a “flying” preamplifier for greater signal-to-noise ratio.

## Features

---

The DAT 72 and DDS-4 drives represent Seagate’s commitment to reliable engineering and durable tape drive products that implement leading-edge technology. Key features of the drives include:

- A platform based on state-of-the-art sealed drive mechanism and tape-handling components for improved immunity to airborne contaminants and extended media life
- Three available form factors: 3.5-inch internal for installation in a 3.5-inch half-height space; 3.5-inch drive with factory-installed 5.25-inch mounting rails and bezel for installation in a 5.25-inch half-height space; and external subsystem with built-in, auto-sensing, worldwide power supply
- ANSI/ECMA compliance and capability to write and read DDS 5<sup>th</sup> Generation (DAT 72 only) DDS-4, DDS-3, and DDS-2 (DDS-4 only) cartridges
- Advanced onboard DDS-DC hardware using Data Compression Lempel-Ziv (DCLZ) data-compression algorithm
- High-speed transfer rates for fast backups
  - DDS-4:
    - 2.75 Mbytes per second typical—uncompressed data
    - 5.5 Kbytes per second typical—compressed data
  - DAT 72:
    - 3.5 Mbytes per second typical—uncompressed data
    - 7.0 Kbytes per second typical—compressed data
- High-performance SCSI burst transfer rate of 10 Mbytes per second asynchronous and 80 Mbytes per second synchronous
- Flash memory to store setup parameters and enable field firmware upgrades
- Four-head design with RAW error detection and rewrites
- Three levels of ECC to ensure data integrity
- Uncorrectable error rate of less than 1 in 10<sup>15</sup> bits
- LVD / Ultra Wide SCSI connection
- Automatic power-on self-test
- Support for TapeAlert™ Certified Solutions

## DAT 72 and DDS-4 Drive Models

The DAT 72 and DDS-4 3.5-inch and 5.25-inch internal drives are tailored for easy installation in today's computers, and the full-featured embedded SCSI controller facilitates easy integration into a variety of systems. DAT 72 and DDS-4 models include:

- A 3.5-inch, half-height drive that mounts internally (see Figure 1)

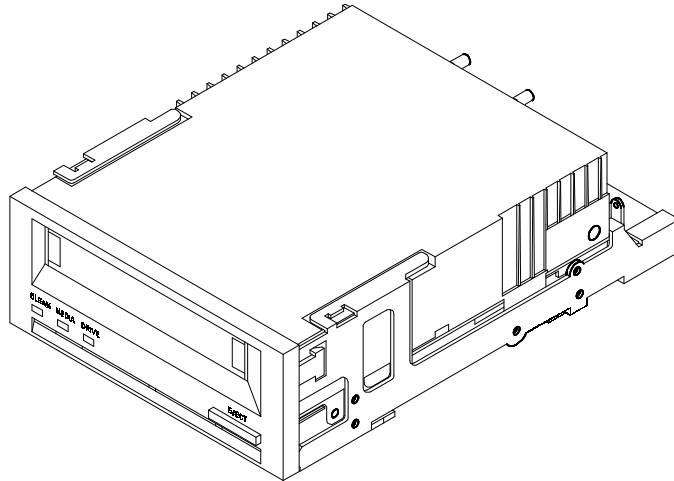

**Figure 1. 3.5-Inch Internal Drive**

- A 5.25-inch, half-height drive that consists of a 3.5-inch drive with 5.25-inch mounting rails and bezel that mounts internally in a 5.25-inch, half-height space (see Figure 2)

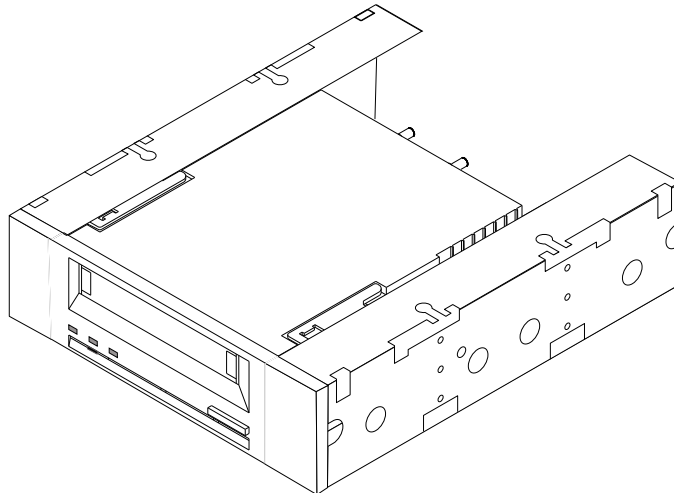

**Figure 2. Internal Drive with Drive Rails for Mounting in a 5.25-inch Drive Bay**

- A complete external subsystem that contains the 3.5-inch drive and built-in worldwide power supply (see Figure 3)

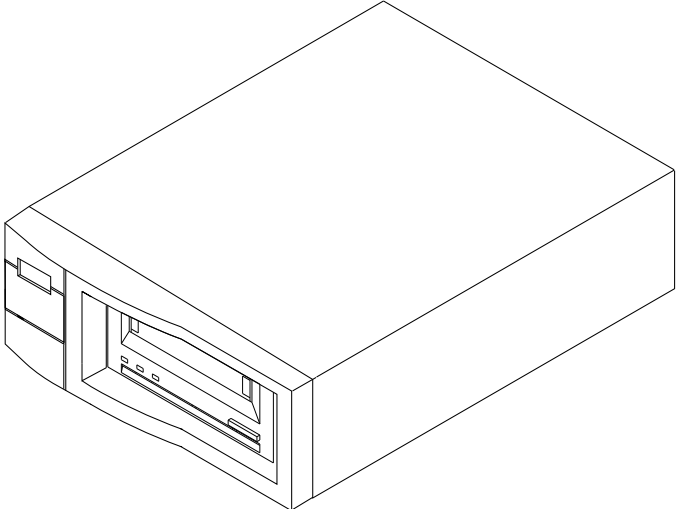

**Figure 3. External Drive**



---

# Specifications

---

# 2

---

## Overview

---

This chapter includes technical specifications for the internal and external SCSI drives. This information covers the following specifications and requirements:

- Physical specifications
- Power specifications
- Drive performance specifications
- Environmental requirements
- Reliability
- DDS cartridge specifications
- Regulatory compliance

---

## Physical Specifications

---

The physical specifications of the internal and external DAT 72 and DDS-4 models are listed in the following table:

<b>Specification</b>	<b>Internal</b>	<b>Internal with rails</b>	<b>External</b>
Height	1.6 in/41.2 mm	1.6 in/41.2 mm	2.7 in/69 mm
Width	4.0 in/101.6 mm	5.74 in/146.0 mm	6.1 in/152.0 mm
Length	5.7 in/146.0 mm	6.9 in/175.0 mm	9.3 in/235.0 mm
Weight	1.4 lb/0.62 kg	1.8 lb/0.87 kg	4.1 lb/1.8 kg

Figures 4 and 5 on the following pages show the dimensions of the internal 3.5-inch and 5.25-inch drives.

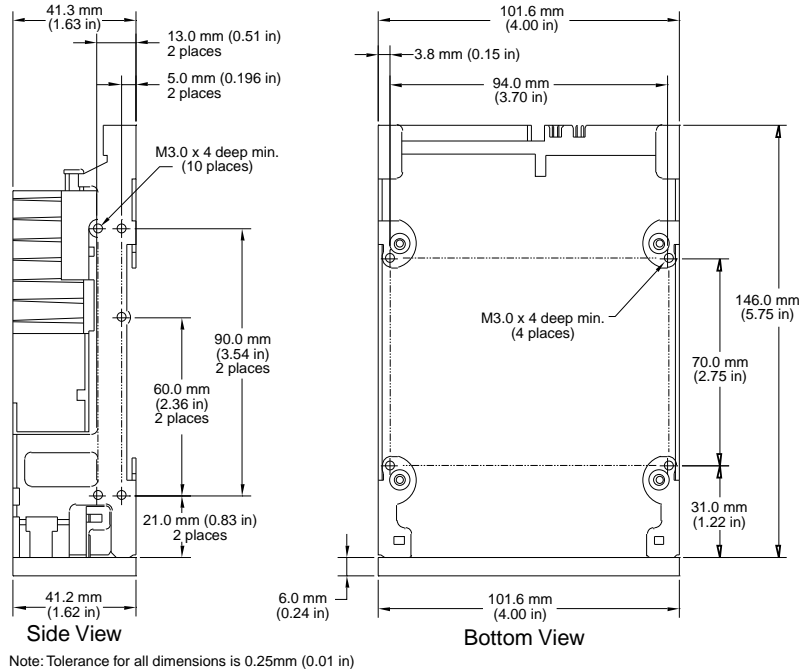

**Figure 4. Internal Drive—Dimensions**

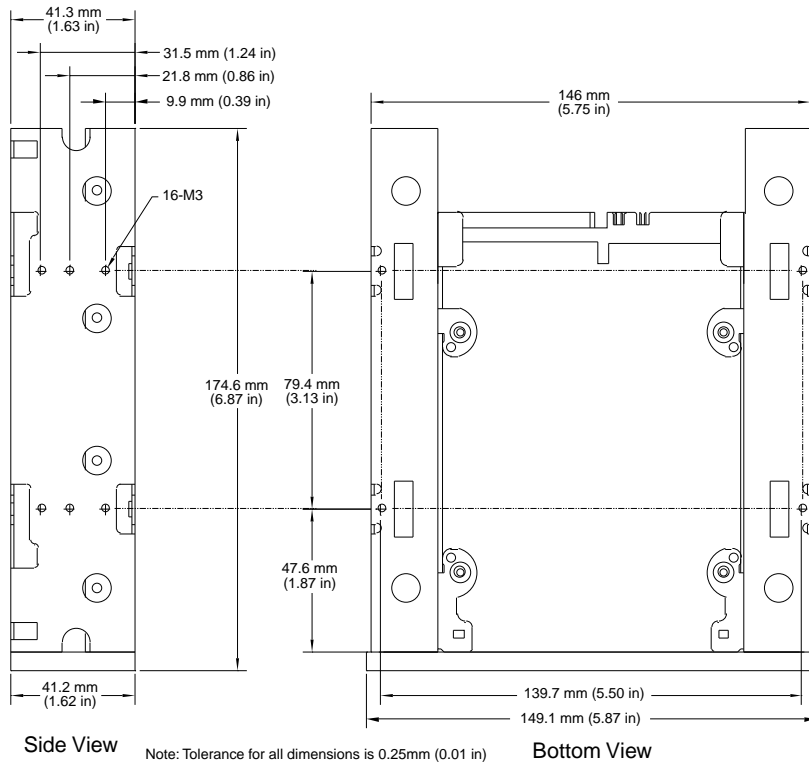

**Figure 5. Internal DDS Drive with Rails—Dimensions**



## Power Specifications

The following table lists the power specifications for the internal DAT 72 and DDS-4 drives.

<b>Specification</b>	<b>+12 VDC supply</b>	<b>+5 VDC supply</b>
Voltage Tolerance	+ or – 10% operating	+ or – 7% operating
Operational Current	250 milliamps max	1.35 Amps max
Standby Current	15 milliamps max	1.2 Amps max
Surge (peak)	600 milliamps max	1.5 Amps max
Ripple (peak-to-peak)	≤ 100 mV (peak to peak)	≤ 100 mV (peak to peak)

Total power consumption for the DAT 72 is as follows:

Standby Power	6.5 watts max
Operating Power	8.7 watts typical, 10.0 watts max
Surge (start up)	20.0 watts max (instantaneous peak)

**Note:** When measured over a 20-msec period, the maximum surge power is 14.0 watts.

Total power consumption for the DDS-4 (including both the +5V and +12V power supplies) is as follows:

Standby Power	6.0 watts max
Operating Power	9.0 watts typical, 10.0 watts max
Surge (start up)	14.0 watts max

**Note:** Surge power and current are measured over a 20-msec period.

The following table lists pin assignments of the power connector for the internal DDS.

<b>Pin</b>	<b>Assignment</b>
1	+12 VDC
2	+12 return
3	+5 return
4	+5 VDC

The external drives have a built-in power supply that senses the incoming voltage and automatically adapts to voltages within the range of 100 to 240 volts, 50 to 60 Hz. The following table lists the power specifications of the power supply.

<b>Specification</b>	<b>AC Input Voltage</b>		
	<i>100 (Japan)</i>	<i>120 (US)</i>	<i>240 (European)</i>
AC Input Current	100 milliamps	85 milliamps	170 milliamps
AC Input Power	10.0 watts	10.0 watts	10.0 watts

**Note:** The drive employs a power-sensing circuit that automatically detects a loss of supply voltage from the host. Temporary loss of supply voltage, or voltage spikes, might result in the drive electronics being reset to their initialized state, but shall under no circumstances result in a loss of recorded data.

## Drive Performance Specifications

The following table lists the specifications for the DAT 72 drive.

<b>Specification</b>	<b>Value</b>
Capacity	
125 m MP++	24.0 Gbytes
150 m MP+++	40.0 Gbytes
170 m MP++++	72.0 Gbytes
Error recovery	Read-after-write (RAW) Reed Solomon ECC (C3 - 3 levels)
Track density (DAT 72)	4704 tracks per inch (TPI)
Recording unrecoverable errors	<1 in 10 <sup>15</sup> data bits
Tape drive type	Computer-grade 4DD mechanism
Head configuration	2 read heads, 2 write heads
Recording format	DDS 5 <sup>th</sup> Generation
Recording method	Helical scan
Cartridge	73.66 mm × 53.34 mm × 10.16 mm
Transfer rate (sustained)	7.700 Kbytes per sec (DC ON)
Synchronous transfer rate (burst)	80 Mbytes per sec max
Asynchronous transfer rate (burst)	10 Mbytes per sec max
Search speed (max)	200x normal (3260 mm per sec)
Average access time	
125 m cartridge	< 30 seconds
150 m cartridge	< 30 seconds
170 m cartridge	< 40 seconds
Drum rotation speed	10,000 Revolutions per Minute (RPMs)
Tape speed	2 meters per second
Head-to-tape speed	15.75 mm/second

The following table lists the specifications for the DDS-4 drive.

<b>Specification</b>	<b>Value</b>
Capacity (with 2:1 compression)	
90 m MP	4.0 Gbytes
120 m MP+	8.0 Gbytes
125 m MP++	24.0 Gbytes
150 m MP+++	40.0 Gbytes
Track density (DDS)	147.34 tracks per mm
Error recovery	Read-after-write Reed Solomon ECC (C3 - 3 levels)
Recording unrecoverable errors	< 1 in 10 <sup>15</sup> data bits
Tape drive type	Computer grade 4DD mechanism
Head configuration	2 read heads, 2 write heads
Recording format	DDS-4
Recording method	Helical scan (R-DAT)
Cartridge	73.66 mm × 53.34 mm × 10.16 mm
Transfer rate (sustained)	5.500 Kbytes per sec (DC ON)
Synchronous transfer rate (burst)	80 Mbytes per sec max
Asynchronous transfer rate (burst)	10 Mbytes per sec max
Search speed (max)	400x normal (3260 mm per sec)
Average access time	
90 m cartridge	<30 sec
120 m cartridge	<40 sec
125 m cartridge	<40 sec
Drum rotation speed	10,000 RPM (all DDS modes)
Tape speed	20.375 mm per sec.
Head-to-tape speed	20.4 mm per sec.

## Environmental Requirements

The following table lists the environmental specifications for DAT 72 and DDS-4 drives. The internal drive should meet these standards if mounted either vertically (on its side) or horizontally (right side up).

<b>Specification</b>	<b>Operational</b>	<b>Nonoperational</b>
Temperature	+41° to +113°F <sup>1</sup> (+5° to + 45°C)	-40° to +149°F <sup>2</sup> (-40° to + 65°C)
Thermal gradient	2°C per minute (no condensation)	Below condensation
Relative humidity	20% to 80% noncondensing <sup>1</sup>	0% to 90% noncondensing <sup>2</sup>
Maximum wet bulb temperature	82.4°F (28°C)	No condensation
Altitude	-100 to +4,575 meters	-300 to +15,200 meters (power off)
Vibration	1.20 mm peak-to-peak	1.5 g (5 to 500 Hz)
Sweep Test	(5–17 HZ) 0.73 G peak (17 to 150 Hz) 0.50 G peak (150–500 Hz) (sweep rate 8 decades per hour)	— — —
Acoustic level idling (A-wt sum)	47 dBA maximum	0
Acoustic level operational (A-wt sum)	53 dBA maximum	0
Shock (1/2 sine wave)	10 Gs peak, 11 msec	100 Gs peak, 11 msec

1. Mechanism and media

2. Mechanism

## Reliability

The DAT 72 and DDS-4 drives are designed for maximum reliability and data integrity. The following table summarizes the reliability specifications.

<b>Specification</b>	<b>Value</b>
Nonrecoverable error rate	< 1 in 10 <sup>15</sup> bits
Error recovery and control	Error-correction code techniques (C1, C2, & C3 ECC) Read-after-write (RAW) DDS: <i>N</i> -Group writing (DDS-2 mode only) Error monitoring and reporting (error log) Retry on read Data randomizer Track checksum
Mean time between failures (MTBF)	412,000 hr at 20% duty cycle
Mean time to repair (MTTR)	Less than 0.5 hour

### ***Mean Time Between Failures***

The mean time between failures (MTBF) is specified at 412,000 hours minimum. This specification includes all power-on and operational time but excludes maintenance periods. Operational time is assumed to be 20 percent of the power-on time. Operational time is the time the tape is loaded on the cylinder (tape moving and/or cylinder rotating).

**Note:** The MTBF rating does not represent any particular drive, but is derived from a large database of test samples. Actual rates may vary from unit to unit.

### ***Mean Time to Repair***

The mean time to repair (MTTR) is the average time required by a qualified service technician to diagnose a defective drive and to install a replacement drive. The MTTR for DAT products is less than 0.5 hour (30 minutes).

The Seagate DDS drives are field-replaceable units. If a problem occurs with a subassembly or component in the drive, you should replace the entire unit. Return the drive to the factory in its original packaging. Contact your distributor, dealer, your computer system company or your Seagate sales representative to arrange the return.

## ***DDS Cartridge Specifications***

---

DDS drives provide maximum data integrity and reliability when Seagate-qualified DDS cartridges are used as the recording media. Seagate maintains an ongoing program to qualify manufacturers of DDS cartridges.

The following cartridges are recommended:

- DDS-2 data cartridge: model STDM8, 120-meter tape (for DDS only)
- DDS-3 data cartridge: model STDM24, 125-meter tape (for DDS only; read-only for DAT 72)
- DDS-4 data cartridge: model STMD40, 150-meter tape
- DAT 72 data cartridge: model CDM72, 170-meter tape
- DDS cleaning cartridge: model STDMCL or CDMCL

Contact your Seagate sales representative for information on qualified DDS data and cleaning cartridge manufacturers and models.

---

## Regulatory Compliance

---

The DAT 72 and DDS-4 drives comply with the regulations listed in the following table.

<b>Agency</b>	<b>Regulation</b>
CSA	C22.2, No. 950-M89
TUV-RHEINLAND	EN 60 950
UL	1950
FCC	Class A and Class B <sup>1</sup>
CE	CE compliance

1. Required compliance for external model; verification on file for internal models.

Use these drives only in equipment where the combination has been determined to be suitable by an appropriate certification organization (for example, Underwriters Laboratories Inc. or the Canadian Standards Association in North America). You should also consider the following safety points:

- Install the drive in an enclosure that limits the user's access to live parts, gives adequate system stability and provides the necessary grounding for the drive.
- Provide the correct voltages (+5 VDC and +12 VDC) based on the regulation applied—Extra Low Voltage (SELV) for UL and CSA and Safety Extra Low Voltage for BSI and VDE (if applicable).

---

# Installation

---

# 3

---

## Introduction

---

This chapter explains how to install the DAT 72 and DDS-4 drives. Some of the information relates to all models; other information is specifically aimed at either the internal or external models. The following paragraphs briefly outline the organization of this chapter.

- **Unpacking and Inspection:** contains general information that you should read before installation.
- **Installing an Internal Drive:** describes how to install a 3.5-inch internal drive and a 3.5-inch drive with 5.25-inch mounting rails and bezel.
- **Installing an External Drive:** describes how to install the external drive.

---

## Unpacking and Inspection

---

Although drives are inspected and carefully packaged at the factory, damage may occur during shipping. Follow these steps while unpacking the drive:

1. Visually inspect the shipping containers and notify your carrier immediately of any damage.
2. Place shipping containers on a flat, clean, stable surface; then carefully remove and verify the contents against the packing list.

If parts are missing or the equipment is damaged, notify your Seagate representative.

3. Always save the containers and packing materials for a future reshipment.

---

## Installing an Internal Drive

---

Internal drive installation involves three main steps:

1. Configuring the drive
2. Mounting the drive
3. Connecting the power and interface cables

**Note:** Internal drives come in two mounting configurations for 3.5-inch and 5.25-inch drive bays, respectively. Drives configured for 5.25-inch bays are identical to those used for 3.5-inch bays, except for the addition of drive mounting brackets on each side of the drive and a different front bezel. Installation procedures are the same for both drive configurations.

## **Guidelines and Cautions**

The following guidelines and cautions apply to handling and installing the internal drive. Keep them in mind as you install the drive.

- Internal drives contain some exposed components that are sensitive to static electricity. To reduce the possibility of damage from static discharge, the drives are shipped in a protective antistatic bag.
- Do not remove the drive from the antistatic bag until you are ready to install it.
- Before you remove the drive from the antistatic bag, touch a metal or grounded surface to discharge any static electricity buildup from your body.
- Hold the drive by its edges only, and avoid direct contact with any exposed parts of the printed circuit board (PCB).
- Always lay the drive either on top of the antistatic bag or place it inside of the bag to reduce the chance of damage from static discharge.

## **Configuring an Internal Drive**

Before you install the tape drive in your computer, you may need to configure the drive's SCSI ID or other drive features. Jumpers located on the back of the drive (between the SCSI interface and power connectors) are used to configure the SCSI ID and to set parity checking and termination power. Other drive features are set using a bank of DIP switches on the underside of the drive.

### **Default Settings**

The default drive settings for the internal drive are listed below:

- SCSI ID: 6
- Media Recognition System (MRS) checking: enabled.
- Parity checking: enabled.
- Data compression: enabled.
- Power-on self-test diagnostics: enabled.
- Host operating system: Windows 98/Me/XP/NT/2000/2003 Server
- SCSI interface compatibility: Wide SCSI supported (LVD and single ended).

If these default settings are appropriate for your needs, skip ahead to "Mounting an Internal Drive" on page 20.

### **Jumper Settings**

Configuration jumpers on the back of the drive are used to control the drive's SCSI ID, parity checking, and SCSI terminator power. The jumpers can also be used for remote SCSI address selection. Figure 6 shows the locations of the jumper blocks for the internal drive.



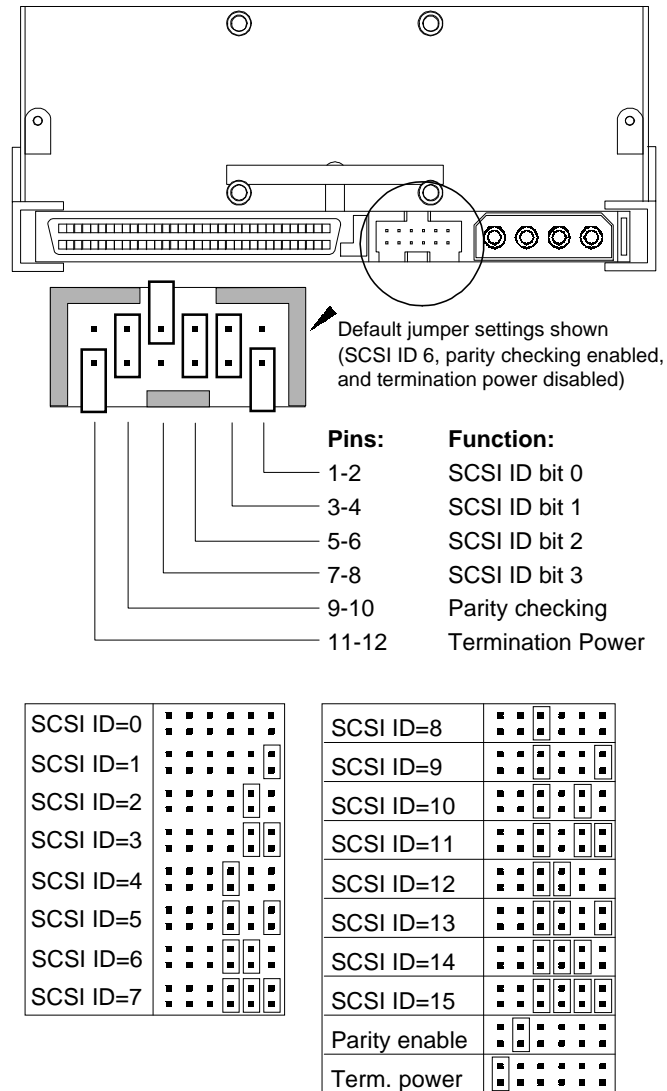

Figure 6. Jumper Settings for an Internal Drive

**SCSI Address Selection (Pins 1 through 8)**

You can select the SCSI address used by the drive by placing the appropriate jumpers on pins pairs 1-2 through 7-8, as shown in Figure 6. The SCSI address can also be selected remotely by connecting a SCSI address-selection switch to pins 1 through 8.

Each SCSI device on a bus must have a unique SCSI ID. The SCSI controller or host adapter generally uses ID 7. In some systems, the boot drive uses ID 0.

**Note:** In an 8-bit SCSI mode, the drive only uses SCSI addresses 0 through 7.

**Parity Checking (Pins 9 and 10)**

If a jumper is installed on pins 9 and 10 (the default setting), parity checking is enabled. If no jumper is installed, parity checking is disabled, but parity is still generated by the drive.

### Terminator Power (Pins 11 and 12)

Internal DAT 72 and DDS-4 drives are shipped with terminator power disabled (no jumper across pins 11 and 12, as shown in Figure 6). You can enable terminator power, if necessary, by placing a jumper across pins 11 and 12.

**Note 1:** If the termination power jumper is installed, be careful not to short the TERMPWR signal to ground (for example, by attaching the SCSI cable upside down). If this occurs, the drive no longer supplies terminator power to the bus. The fuse resets automatically after the short is corrected.

**Note 2:** The internal DAT 72 and DDS-4 do not provide SCSI termination, and therefore should not be installed as the last device in a SCSI chain. See “Connecting the SCSI interface cable” for details.

### DIP Switch Settings

Figure 7 shows the location of DIP switches on the *underside* of the internal drive. Each of these switches is described in detail on the following pages.

If you change a DIP switch, the new setting does not take effect until you turn the drive off, and then on again.

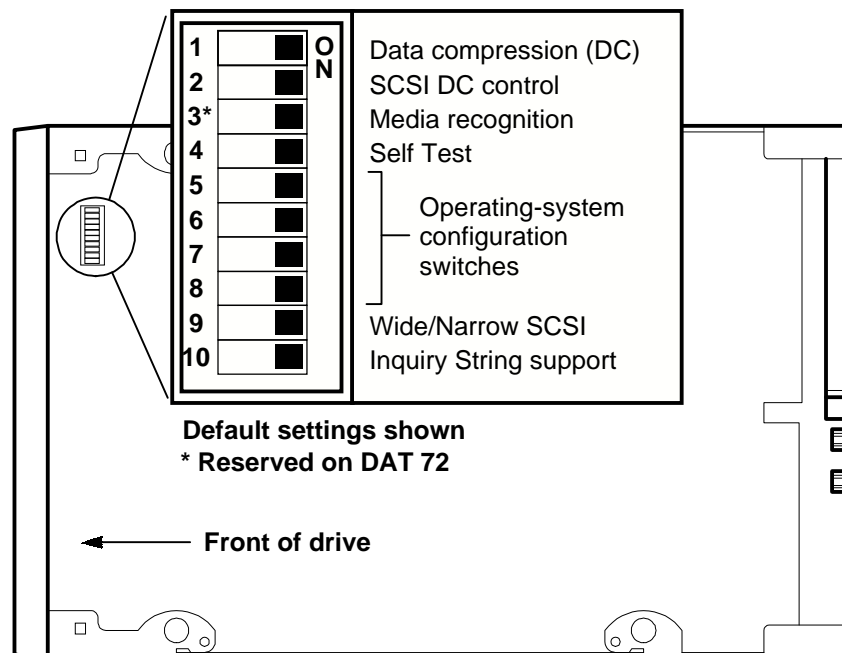

Figure 7. DIP Switch Settings for an Internal Drive

### Data Compression (Switches 1 and 2)

If switch 1 is ON (the default setting), hardware data compression is enabled. If switch 1 is OFF, hardware data compression is disabled.

If DIP switch 2 is ON (the default setting), SCSI commands can be used to enable or disable hardware data compression. To prevent hardware data compression from being enabled or disabled by SCSI commands, set DIP switch 2 to OFF.

### Media-Recognition System (Switch 3)

The media-recognition system allows the drive to determine whether a given tape cartridge conforms to the DDS tape standard. Use of non-DDS media may appear to give satisfactory results, but the inferior specifications of such media can cause data-integrity problems.

Switch 3 is reserved on DAT72 drives. On DDS-4 drives, switch 3 enables or disables the media-recognition system (MRS). If switch 3 is ON (the default setting), the drive reads and writes to MRS media and reads from but does not write to non-MRS media. If switch 3 is OFF, the drive reads or writes both MRS and non-MRS media.

### Power-on Self-Test Enable/Disable (Switch 4)

Switch 4 enables or disables execution of power-on self-test diagnostics when the drive is powered on. If switch 4 is ON (the default setting), the drive responds to SCSI commands only after successful completion of the self-test (about 5 seconds). If switch 4 is OFF, the drive does not perform a power-on self-test.

### Operating System Configuration (Switches 5 through 8)

Switches 5 through 8 configure the drive for use with UNIX and other non-Windows operating systems. See the *DAT 72 Configuration Guide* or *DDS-4 Installation Manual* for details. The default setting for all four of these switches is ON.

### SCSI Wide/Narrow (Switch 9)

Switch 9 is reserved on DAT72 drives. On DDS-4 drives, switch 9 enables or disables SCSI Wide operation on the SCSI bus. When switch 9 is ON (the default setting), the drive is capable of operating in Wide (16-bit) SCSI mode. When switch 9 is OFF, the drive operates only as a Narrow (8-bit) SCSI device.

**Note:** If switch 9 is set to OFF, the drive can use SCSI ID values 0 through 7 only.

### Inquiry String Switch (Switch 10)

Switch 10 is used to select the Vendor ID that the drive returns when queried with a SCSI Inquiry command. When switch 10 is ON (the default setting), the Vendor ID is "SEAGATE DAT." When switch 10 is OFF the Vendor ID is "ARCHIVE Python." The "ARCHIVE Python" Vendor ID may be used by independent software vendors to provide software compatibility with previous Seagate DDS tape drives.

### Mounting an Internal Drive

You can install your Seagate internal DDS drive horizontally or vertically (on its side). Figure 8 shows a 3.5-inch drive being installed in a typical system using side mounting screws.

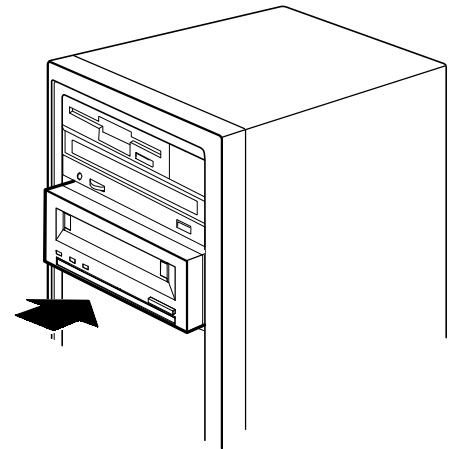

#### Mounting the Drive in a 3.5-Inch Drive Bay

Mount the drive in a 3.5-inch drive bay and secure it using two M3.0 metric screws on each side of the drive. Do not use nonmetric screws or screws longer than 4 mm or you might damage the drive. As shown in Figure 9, the 3.5-inch drive has four screw holes on the bottom and five on each side.

Figure 8. Mounting an Internal Drive

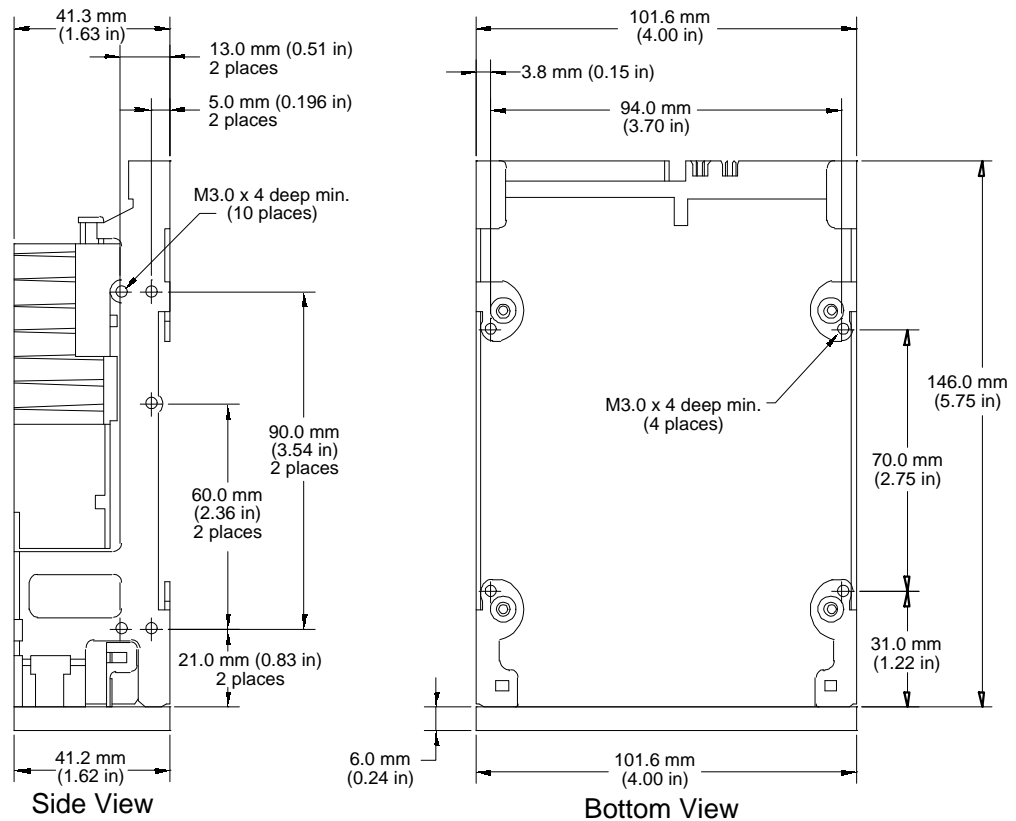

Note: Tolerance for all dimensions is 0.25mm (0.01 in)

Figure 9. Mounting Holes for an Internal Drive in a 3.5-inch Configuration (without mounting brackets)

### Mounting the Drive in a 5.25-Inch Drive Bay

If you are mounting the drive in a 5.25-inch drive bay, you must use a drive with mounting brackets attached. As shown in Figure 10, the 5.25-inch drive brackets have four screw holes on the bottom and six on each side.

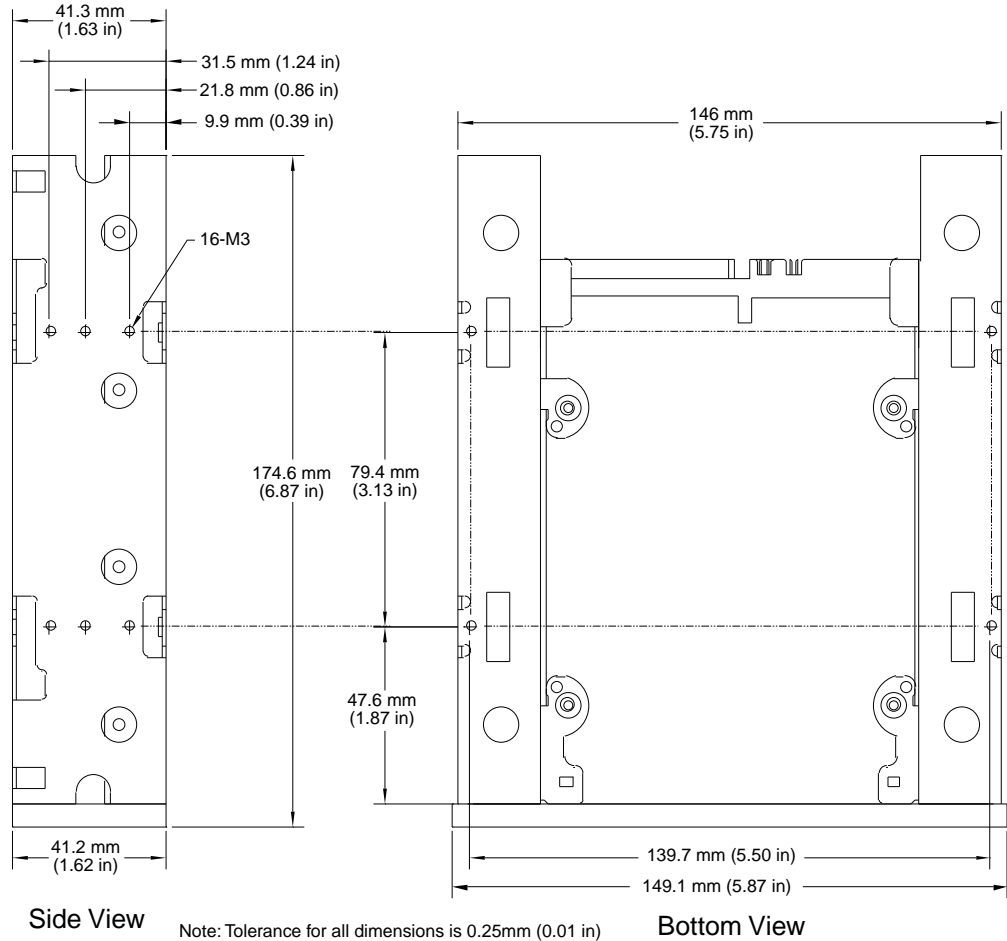

**Figure 10. Mounting Holes for an Internal Drive in a 5.25-inch Configuration (with mounting brackets)**

### Connecting the SCSI Interface Cable

DAT 72 and DDS-4 drives can be used with two different types of SCSI interfaces: Ultra2 SCSI (LVD) or "Wide" (16-bit) single-ended SCSI bus. The drive can automatically detect whether it is connected to an LVD or single-ended wide SCSI bus.

**Note:** The DAT 72 and DDS-4 drives do not work in a SCSI-1 environment.

### Connecting to a 68-pin Wide SCSI or LVD Bus

To connect the drive to an LVD or wide SCSI bus, first turn off all power to the drive and computer. Then attach the interface cable to the SCSI interface connector on the back of the drive (see Figure 11).

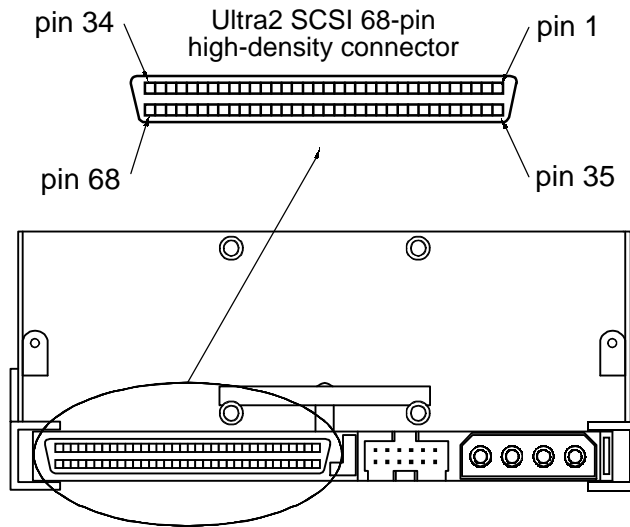

Figure 11. Interface Connector on an Internal Drive

**SCSI Termination**

The internal DAT 72 and DDS-4 drives do *not* provide SCSI termination. For this reason, they should not be the last device on a SCSI chain. Two termination examples are shown in Figure 12. If the drive is the only SCSI device, attach the drive to the connector which is next to last on the SCSI chain and attach a multimode terminator to the last connector in the chain.

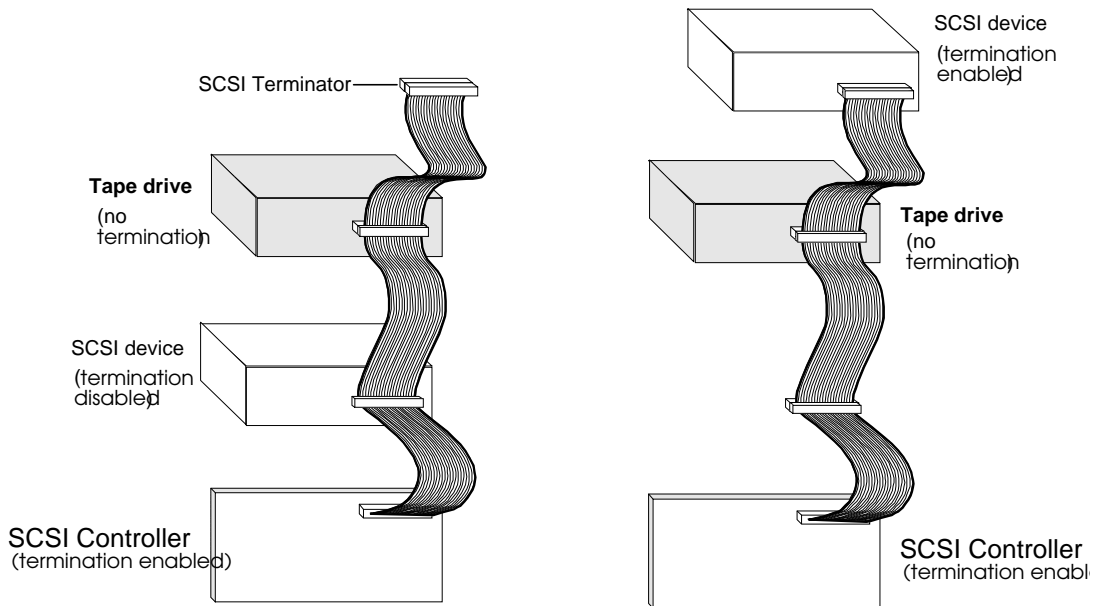
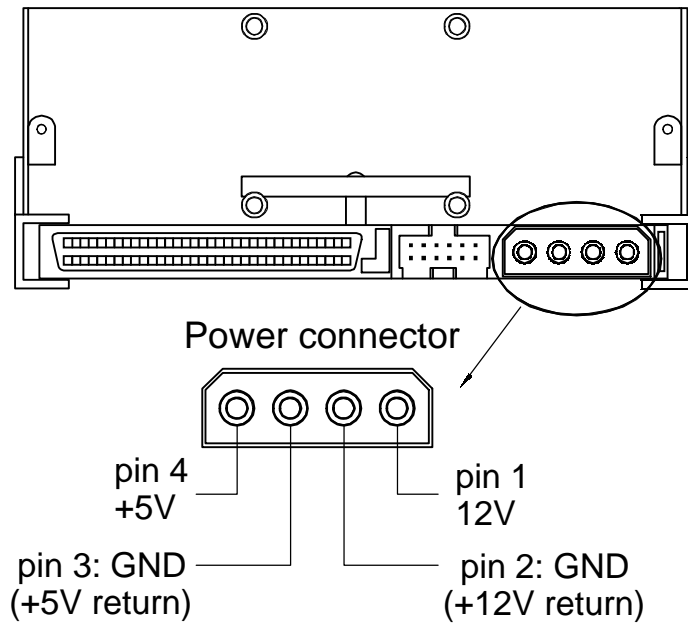

Figure 12. Two SCSI Termination Examples for Internal Drives

**Connecting a Power Cable**

Attach a four-pin power cable to the power connector on the back of the drive. Figure 13 shows the location of the power connector.

The recommended 4-pin power connector for the internal drive is an AMP 1-48024-0 housing with AMP 60617-1 pins or their equivalent.



**Figure 13. Power Connector on the internal Drives**

## Installing an External Drive

The external drive is a compact external SCSI device that connects to the host computer as a turnkey subsystem. Installing the external drive involves three simple steps:

1. Configuring the drive
2. Connecting the SCSI interface cable
3. Connecting the power cord

### Configuring the External Drive

The following is the default configuration for the external drive:

- The SCSI ID: 6
- Media Recognition System (MRS) checking: enabled
- Parity checking: enabled
- Data compression: enabled
- Power-on self-test diagnostics: enabled
- Host operating system: Windows 98/Me/XP/NT/2000/2003 Server
- Termination power: supplied to the SCSI bus

**Note:** Some of these configuration settings can be changed using the SCSI Mode Select command. SCSI command information for these drives is provided in the product description manual.

### Setting the SCSI ID

Make sure that the drive is turned off; and then set the SCSI ID for the drive using the push-button switch on the back of the external drive. Figure 14 shows this switch, as well as the two SCSI interface connectors, on/off switch, and the power-cord connector.

**Note:** The drive must be restarted, or a bus reset must occur for any change in a SCSI ID to take effect.

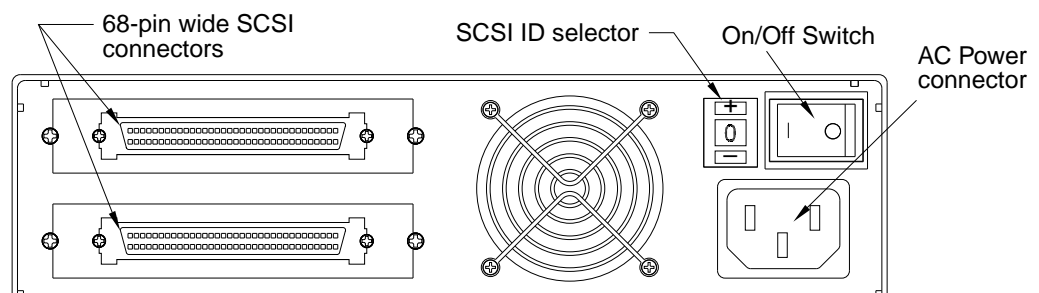

Figure 14. Rear Panel of External Drives



## Connecting the SCSI Interface Cable

The external drive provides two 68-pin, shielded connectors on the rear panel of the enclosure. Either connector can be used as a SCSI IN or SCSI OUT connection (you can use either connector to attach the drive to the host computer or to another SCSI device).

Turn off your computer and all SCSI devices. Then attach a SCSI cable from the host adapter or from another (unterminated) SCSI device to the external drive.

**Note:** The DAT 72 and DDS-4 drives do not work in a SCSI-1 environment.

### SCSI Termination

If the DAT 72 or DDS-4 drive is the last device or the only device in a SCSI chain, you must install a terminating plug on the unused SCSI connector. See Figure 15 for two SCSI termination examples.

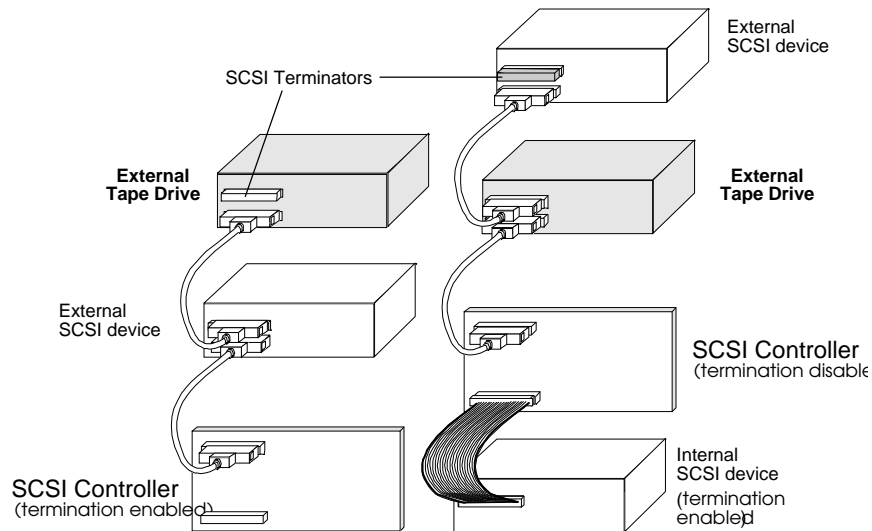

Example 1: SCSI termination in a system that has only external SCSI devices.

Example 2: SCSI termination in a system that has both internal and external SCSI devices.

Figure 15. SCSI Termination Examples for External Drives

## Connecting the Power Cord

Attach the power cord securely to the power connector on the back of the drive. The location of the power connector is shown in Figure 14.



## Drive Operation and Maintenance

# 4

### Loading a Cartridge

Seagate DAT drives have a front-loading cartridge bay for easy operation. The drive-bay door opens automatically when a cartridge is inserted. Figure 16 shows a cartridge being inserted into a 3.5-inch internal drive. After you insert the cartridge, there is a brief delay while the drive identifies the cartridge type and state and moves the tape to the data area.

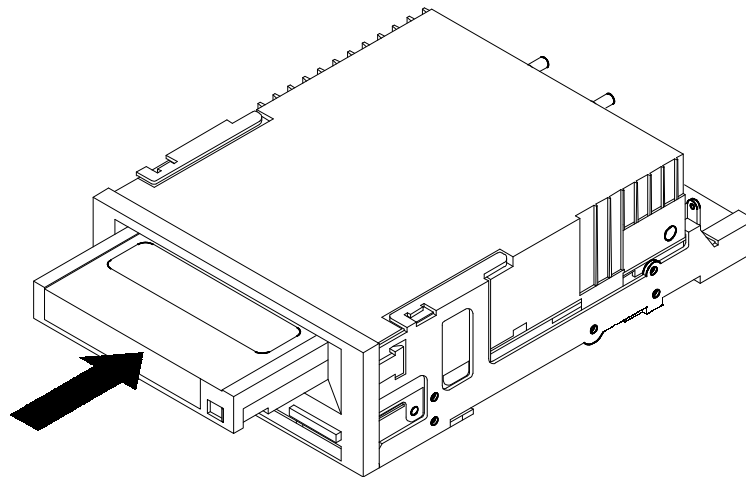

Figure 16. Loading a Tape Cartridge

### Unloading a Cartridge



**Caution.** To ensure the integrity of your backups and restores, do not push the eject button while the drive-status light-emitting diode (LED) is ON. See Figure 17 for the location of drive LEDs.

Make sure that the amber drive-status LED is not lit. Then unload the cartridge by pressing the eject button. For the location of the eject button, see Figure 17. After you press the eject button, the drive automatically flushes the drive buffer to tape, rewinds the cartridge, and updates the system log before ejecting the cartridge.

Up to three minutes may elapse between the time you press the eject button and the time the cartridge is ejected. Do not power down the tape drive or the host computer during this time.

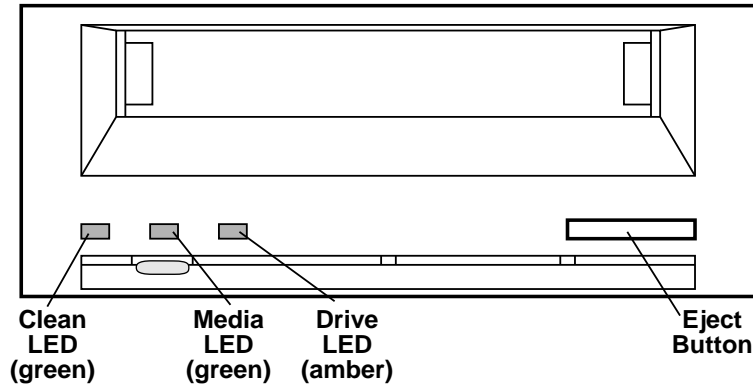

Figure 17. Location of the Eject Button and LEDs on internal Drives (external drive is similar)

## ***Initializing a Blank Cartridge***

---

When you insert a blank cartridge into the drive for the first time, the drive takes about 10 to 12 seconds to determine that the tape is blank. The drive automatically initializes the tape as soon as it receives a Write command from the host computer. Initializing a blank tape takes about 30 seconds.

## ***DDS Cartridge Compatibility***

---

The Seagate DAT 72 and DDS-4 drives are designed to use data-grade DAT cartridges, which comply with ANSI specifications listed in the "3.81 mm Helical-Scan Digital Computer Tape Cartridge for Information Interchange," ANSI X3B5/89-156 standard.

MRS cartridges have a series of alternate opaque and clear stripes at the beginning of the tape. These stripes classify the media as datagrade.

## ***Write-Protecting a Cartridge***

---

Figure 18 shows how to write-protect or write-enable a DAT tape using the sliding write-protect tab. You can only write data to the tape when the tab is in the write-enabled (closed) position.

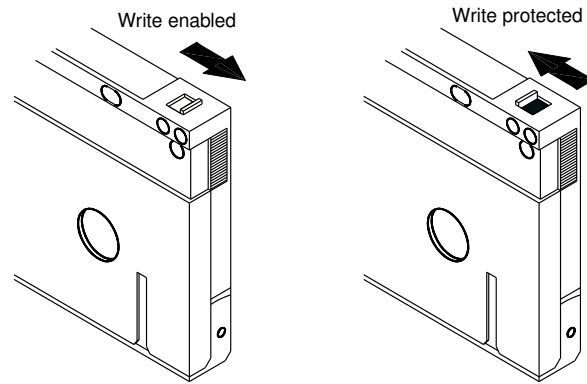

Figure 18. Write-Protect Tab on a DDS Cartridge

## LED Codes

As shown in Figure 19, the front panel of the DDS drive contains three LEDs that provide information about both normal and error conditions. The external drive also includes a green power-on LED on the front panel.

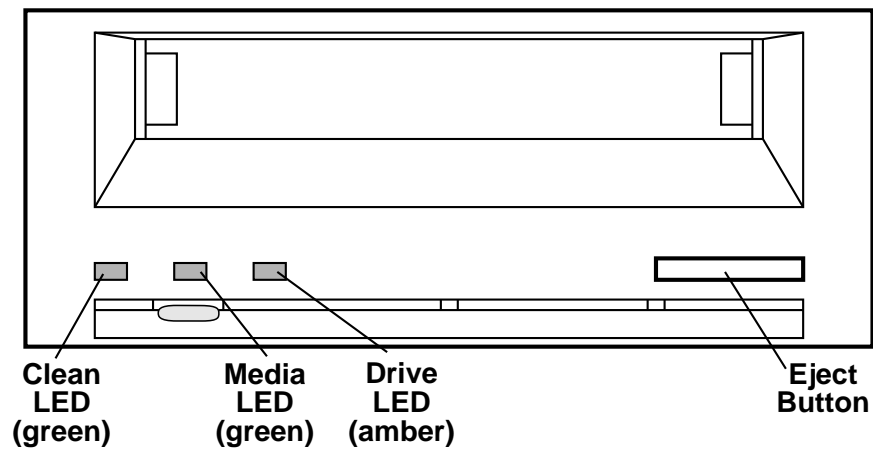

Figure 19. Front Panel of an Internal Drive  
(external drive is similar)

## **Clean LED**

If the Clean LED is ON continuously, the drive requires cleaning. Use only an approved DDS cleaning cartridge. Following is a guideline for cleaning intervals based upon drive type:

- **DDS-4**  
DDS2, DDS3, or DDS4 media has been operating in the drive for at least 50 hours.
- **DAT 72**  
DDS3, DDS4, or DAT 72 media has been operating in the drive for at least 50 hours.

If the Clean LED is flashing slowly (approximately ON 2 seconds, OFF 1 second), the tape cartridge currently in use has exceeded a predefined soft-error threshold. This signal is a warning only and does not indicate that data has been compromised. If you see this signal, remove the tape at your earliest convenience and clean the drive using an approved DDS cleaning cartridge. If, after cleaning the drive and reinserting the original data cartridge, the Clean LED still flashes, you should use a new cartridge for future backups.

If the Clean LED flashes rapidly, a cleaning cartridge that has exceeded its useful life has been inserted into the drive. Replace the cleaning cartridge with a new approved DDS cleaning cartridge.

## **Media LED**

The Media LED functions as follows:

- If the Media LED is ON (lit) continuously, a DDS cartridge has been inserted and the drive is operating normally.
- If the Media LED is flashing rapidly, the drive could not write to the tape correctly (maximum rewrite count exceeded), and the write operation failed. Clean the drive heads using an approved DDS cleaning cartridge. If you reinsert the original data cartridge and the LED continues flashing, insert a new data cartridge and retry the operation.

**Note:** As routine maintenance, you should clean the drive heads after every 50 hours of operation.

## **Drive LED**

- If the Drive LED is ON continuously, the drive is reading from or writing to the tape (that is, SCSI or tape movement is present). If you push the eject button while the Drive LED is ON, you might lose data.

**Note:** If your backup software issues a SCSI Prevent Media Removal command, the Drive LED remains ON and the eject button is disabled so that the tape cannot be accidentally ejected. To eject the tape, use your backup software's Eject function.

- If the Drive LED is flashing rapidly, a hardware fault has occurred. If this fault occurs immediately after powering on the drive, then the Power-On Self-Test switch is enabled and a Power-On Self-Test has failed. If the front panel LEDs flash together, contact the Seagate Technical Support department for information. If the Drive LED is flashing rapidly during drive operation, attempt to remove the tape by pressing the eject button. If the tape does not eject within 2 minutes, press and hold the eject button continuously for more than 5 seconds. The tape should eject within 40 seconds. Contact Seagate Technical Support for more information.

### ***LED Code Summary***

The following table summarizes LED flash codes for the DAT 72 and DDS-4 drives.

<b><i>LED</i></b>	<b><i>Action</i></b>	<b><i>Meaning</i></b>
<b>Clean</b>	ON (lit)	Cleaning is required because the drive has been operating for at least 50 hours.
	Flashing Slowly	The internal error rate threshold has been exceeded and cleaning is required.
	Flashing	The cleaning cartridge in the drive has exceeded its useful life. Replace the old cleaning cartridge with a new one.
<b>Media</b>	ON (lit)	A cartridge is inserted and is not generating excessive errors.
	Flashing	The drive could not write to the tape correctly (a write error has occurred). Use a DDS cleaning cartridge to clean the drive.
<b>Drive</b>	ON (lit)	The drive is reading from or writing to the tape normally.
	Flashing Rapidly	A hardware fault occurred.

## ***Cleaning the Tape Heads***

### ***When to Clean the Tape Heads***

If excessive dust or debris from the tape media collects at one or more of the tape heads, your drive might not be able to read from or write to the tape. To avoid this situation, you must clean the tape heads on your DDS in the following circumstances:

- after every 50 hours of operation
- if the Clean LED lights up or flashes
- If the Media LED flashes during drive operation.

**Note:** If cleaning the head does not correct a flashing LED condition, try using a new data cartridge.

### ***How to Clean the Tape Heads***

To clean the tape heads on your drive, use only a Seagate-qualified DDS cleaning cartridge. Seagate offers a cleaning cartridge, Model STDMCL or CDMCL, available from <http://shop.certance.com>. Do not use an audio DAT cleaning cartridge. The drive cannot recognize it.

After you insert the cleaning cartridge, the drive detects that the cartridge is a cleaning cartridge, and loads and runs the cartridge for about 30 seconds. When cleaning is complete, the drive ejects the cartridge.

Each time the cleaning cartridge is loaded, a new, unused portion of cleaning tape is advanced over the entire tape path. The drive does not rewind a cleaning cartridge. After about 30 cleaning cycles, the entire tape is used. If you insert a completely used cleaning cartridge, the Clean LED flashes rapidly. Replace the cleaning cartridge.

### ***Automatic Drive Spin-Down and Write***

---

To maximize tape and drive mechanism life, the drive automatically stops the cylinder when no tape read or write activity occurs.

If a read or write operation occurs, normal operation resumes with no affect on the host operation.

If tape write operations cease, a partially full data buffer may remain. After one minute with no activity, the drive automatically writes the partial buffer to the tape. This automatic action minimizes the possibility of lost data if the power fails.

If data to be written remains in the buffer when the eject button is pushed, the data is written to tape before the tape is rewound and ejected.

### ***Operating the Drive in High-Temperature or Humidity Conditions***

---

Being faithful to the following guidelines can minimize the possibility of damaging the drive due to operation during extreme temperature or humidity conditions (outside the specified operating environment).

- Use DDS cartridges only at temperatures between 5°C (40°F) and 40°C (113°F). The cartridges can be stored at temperatures down to -40°C (-40°F). Although the storage specifications range from 5°C to -40°C, do not leave cartridges in severe temperature conditions—such as in a car in bright sunlight. Avoid extreme changes in temperature or humidity whenever possible.
- If cartridges are exposed to temperatures or humidities outside the specified operating environment, condition the cartridges by exposure to the subsequent operating environment for a time at least equal to the period the cartridges were exposed to the out-of-spec environment.



- Place the drive in a position that provides stable temperatures. Do not place the drive near open windows, fans, heaters or doors.
- Do not read from or write to cartridges when a temperature change of 10°C per hour is occurring.

---

## **Data Compression**

---

Default operation for the DAT 72 and DDS-4 drives is to have data compression enabled—the drive automatically compresses all data written to tape and decompresses all compressed data read from tape.

The degree of compression varies with the type of data being processed.

Data with high degrees of redundancy, such as structured database files or graphics files, can be compressed most efficiently, often at a ratio of 2:1 or more. Data with little redundancy, such as executable programs, can be compressed the least.

The SCSI Mode Select command can switch the drive into compressed or uncompressed mode for writing data regardless of the position of switch number 1 (see "Data compression (switches 1 and 2)" in Chapter 3). When reading, the drive automatically selects compressed or uncompressed mode, depending on the data that is read.

---

## **Loading Revised Firmware from Seagate Firmware Cartridges**

---

### **Flash Memory**

Another technological advancement incorporated into the DAT 72 and DDS-4 drives is flash memory, which is useful if the drive's SCSI firmware needs to be upgraded. With the permanently installed, electrically upgradeable flash memory, revised SCSI firmware for the drive can be loaded through:

1. Seagate OEM firmware cartridges
2. The host SCSI bus; or
3. The drive serial port.

The flash memory feature enables qualified OEMs who need to revise DAT 72 and DDS-4 drive SCSI firmware to do so quickly and easily. Flash memory also prolongs the life cycle of a drive because many new techniques—such as increasing the capacity of the drive through support for longer tapes—may require only a firmware upgrade.

### **Firmware Download Process via Tape**

To load a firmware upgrade tape, follow these steps.

1. Power on the host system with the DAT 72 or DDS-4 drive installed.

2. Make sure that no applications are running that may try to communicate to the drive during the firmware upgrade process. Close any such applications before inserting the firmware upgrade cartridge.
3. Insert the firmware upgrade cartridge.



**Caution.** Once the firmware upgrade cartridge is inserted into the drive, it is important that no power interruption occurs while the firmware is loading. *Do not power off the drive.* If a power interruption occurs, the firmware may not be loaded correctly, and the drive may not operate properly.

4. The drive automatically recognizes the firmware upgrade cartridge and begins downloading the firmware from the cartridge into DRAM.
5. The drive ejects the firmware upgrade cartridge as soon as the firmware has been completely downloaded into DRAM and the LEDs begin blinking with a progressive pattern. When the blinking pattern stops, the firmware upgrade operation is complete.



**Caution.** Do not power down the host system or disconnect power to the drive until you have completed step 6. Doing so could render the drive inoperative.

6. Power down the system and reboot. The new firmware is immediately active and operational.

**Note:** At this time, it is recommended that you power cycle the drive to refresh any new parameter information and to execute the power-on self-test to ensure proper unit functionality.

Firmware upgrade cartridges are available only to qualified Seagate OEM customers. Contact your Seagate sales representative for information.

**Note:** The firmware can also be upgraded from a host computer via the SCSI connection using software available at <http://support.certance.com/support/tape/utis/index.html>.

---

# **Theory of Operations**

---

# **5**

---

## **Overview**

---

The Seagate DAT 72 and DDS-4 tape drive design integrates DAT technology (helical scan recording method) into a true computer-grade data-storage peripheral with industry-standard data-compression capability.

These drive designs are the result of:

- Combining the economies of scale for key components, such as the cylinder, heads, and audio Application Specific Integrated Circuits (ASICs), with a computer grade drive (3.5-inch) using four direct drive motors and electronic tape path control for the demanding computer storage environment.
- Implementing a four-head design to provide read-after-write (RAW) error correction and to maximize the benefits of the helical scan recording method, namely: (1) high-density recording (all tape space is used by dense, overlapping tracks at alternating azimuth angles) and (2) high-speed searches.
- Using 5<sup>th</sup>-generation custom ASICs for efficient circuit layout and increased reliability with low power consumption. These LSIs are quad-flat-pack (QFP) designs that use complementary metal-oxide semiconductor (CMOS) technology.
- Using flash memory devices for easy firmware upgrades.
- Storing configuration information in the parameter block of flash memory.
- Implementing custom C3 ECC 1, 2, and 3 and other error-correction techniques.
- Embedding a full-LSI SCSI controller with capability for SCSI-2 command sets in LVD SCSI DDS-DC models.
- Embedded 40 MHz (DDS-4) and 70 MHz (DAT 72) ARM CPUs with cache.
- 8-Mbyte SDRAM data buffer.

This chapter describes the DDS drive in more detail and explains implementation-specific information.

### **Drive Mechanism**

The drive uses the helical scan recording method with a four-head cylinder design. Four direct-drive motors and one brush-type motor are used in the drive. The read and write functions use LSIs. Engineering decisions—such as the modular partitioning of the electronics and use of surface-mount, low-power commercial and custom LSIs—allow the drives to conform to the industry-accepted 3.5-inch form

factor. These design features are also important contributors to the overall reliability, durability and performance of the drive.

The mechanism is designed for minimum tape wear and prevention of damage to the tape. The modes or operational states, such as stop, rewind and play, reduce mechanism and tape wear. Fewer mechanical mode changes result in less wear on key drive components. In some cases, the need for a mode change is circumvented using the Pause mode, which stops the tape without activating the mechanism. All mode selection is performed by the controller firmware. The host computer does not directly control mode selection.

A custom timing tracking design, combined with the four-head cylinder design, implements the specifics of the DAT 72 and DDS-4 recording format standards and provides the precision required to perform seamless appends, or the ability to add subsequent recorded data frames immediately adjacent to the last data frames written on the tape.

A bank of jumpers is available at the rear of the drive. These jumpers allow you to set the SCSI ID for the drive and to change configuration choices. Refer to Chapter 3 for information about setting these jumpers.

By using the jumpers, you can also enable terminator power if needed. (The default for internal models is with terminator power disabled. For external drives, the default is with terminator power enabled.)

**Note:** The DAT 72 and DDS-4 drives come with a terminator power fuse to provide protection from component damage in case the SCSI cable is connected incorrectly.

Three rectangular front-panel LEDs indicate a drive busy status and tape cartridge in place status. When blinking, these LEDs also function as fault indicators. (Refer to Chapter 4 for a summary of the function of these LEDs.) The external subsystem also provides a round, green LED on the front panel to indicate that the power is on.

### Helical Scan Recording—Four-Head Design

In helical scan recording, the heads are positioned opposite one another on a cylinder, which is tilted approximately 6 degrees from the vertical plane and rotates counterclockwise at 10,000 revolutions per minute (rpm). At the same time, the tape moves slowly (20.375 mm per second in DDS-4 mode) in a horizontal path around part of the cylinder. This simultaneous motion of cylinder and tape results in the head traveling across the width of the tape in a helix-shaped motion.

The cylinder is designed with four, long-life heads—two read and two write heads. These heads are set opposite one another with a rotation sequence of: write A, read B, write B, read A (or write A new, read B old, write B new, read A old). The advantage of this design is that a RAW check is performed immediately after the data is written.

As mentioned earlier, the cylinder rotates rapidly (10,000 rpm) in the same direction that the tape moves. The wrap angle of the tape on the cylinder is approximately 102 degrees. The combined movement of the tape and cylinder results in a relative head-tape speed of 20.4 inches per second (ips).

Figure 20 illustrates a helix track and the four-head design, and shows the 102-degree wrap angle.

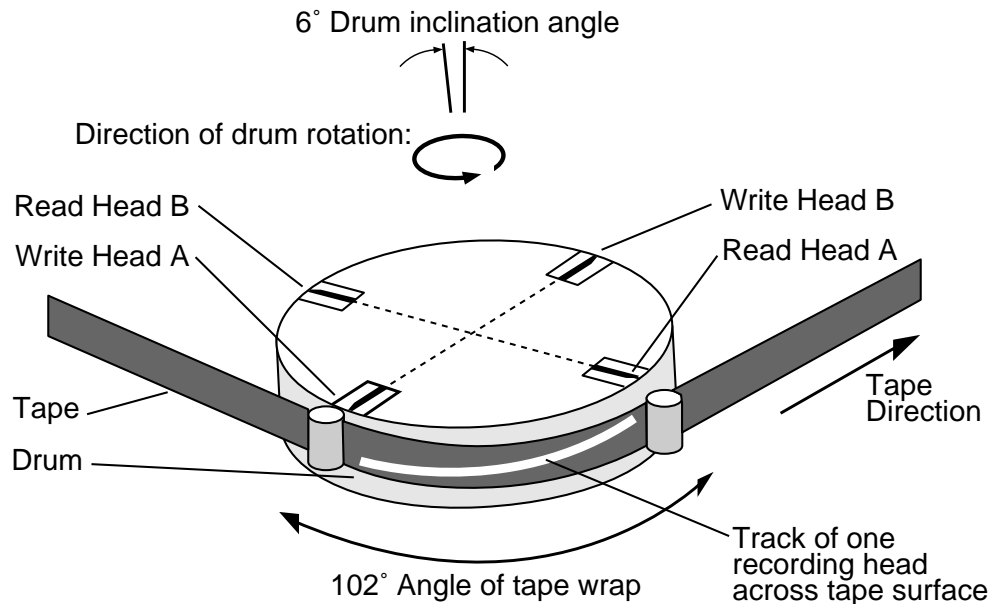

**Figure 20. Four-Head Cylinder Design**

The recorded tracks are written diagonally across the tape from bottom to top by each write head. Because the head is wider than the track written, tracks overlap with no tape space between them. In conventional recording, such overlap or even proximity results in crosstalk (signals from adjacent tracks interfering with signals from another track).

However, in helical scan recording, the heads are set at different azimuth angles so that alternate tracks on the tape are written at alternate azimuth angles. (See Figure 21) Because the read head is set to the same angle as its corresponding write head, it picks up a stronger signal from data written in the same azimuth angle as itself. So it reads the track with minimal crosstalk. At the same time, the head is maintained centered in the track by the timing tracking hardware and firmware.

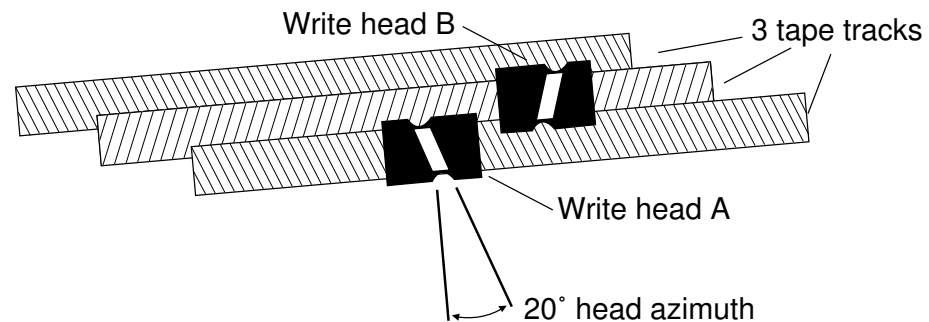

**Figure 21. Alternating Azimuth Angles on Tape Tracks**

---

## ***Motors and Control Circuits***

---

The drive uses four direct-drive, brushless motors—the capstan, cylinder and two reel motors. Using these small, direct-drive motors provides maximum reliability. The cylinder motor rotates the cylinder. The capstan motor moves the tape. The mode motor loads and ejects the cartridge. The two reel motors turn the tape reels.

The cylinder, capstan and reel servos are controlled by custom ASICs and the motor-control firmware.

The fifth motor in the mechanism is a brush-type mode motor. This motor controls (selects) the mechanism mode. Because the mode motor is not frequently used, and due to space and torque requirements, a brush-type motor is best suited to this application. The mode motor performs the mode changes as directed; for example, this motor conditions the mechanism to eject the cartridge.

### ***Timing Tracking Circuitry***

The timing tracking circuitry of the drive is designed to provide high precision tracking and head positioning. The timing tracking system, in conjunction with the four-head read-after-write (RAW) design provides for reliable high-density data recording with maximum storage efficiency.

### ***Signal-Processing Electronics***

The signal-processing electronics circuitry in the drive is made up of several components. The drive's main control microprocessor, data engine, and data buffer management circuitry are all integrated in a single IC package. A single-chip DDS formatter LSI communicates with the microprocessor and with the read and write LSIs. The C3 ECC coprocessing capability and a second buffer memory control function are also included in this IC. Other vital components are the high-performance SCSI LSI chip, the flash memory, and the DRAM buffer memory.

---

## ***Flash Memory***

---

Because the drive uses flash memory, the drive firmware can be easily upgraded when new revisions of the firmware are released. The flash memory is 1 Mbyte in size.

You can load new firmware in one of three ways:

- Using a specially encoded firmware upgrade cartridge
- Issuing a SCSI Write Data Buffer command to download the firmware to the EEPROM
- Through the drive serial port

Refer to Chapter 4 for information about loading new firmware using a Seagate firmware upgrade cartridge.

---

## Sensors

---

A number of mechanical and optical sensors are integrated in the drive design. The *cartridge in* and *cartridge loading* sensors are mechanical sensors that determine the position of the loading mechanism. The other mechanical sensors report specific information based on detecting the open or closed state of four recognition holes in the DAT cartridge. The open or closed state of these holes designates tape type, that is, whether the tape is a cleaning cartridge, whether the tape is prerecorded and whether the tape cartridge is write-protected. These mechanical sensors and the sensor for the cartridge in status comply with the DDS standard requirements for the cartridge.

The beginning-of-tape (BOT) sensor is an optical sensor that uses the light path transmissivity of leader tape, as specified in the DDS cartridge standards. The sensor is also designed to recognize media recognition system (MRS) cartridges, which have a series of alternate opaque and clear stripes at the beginning of the tape.

The reel sensors for the two reels are optical. Optical sensors also detect the mechanism position during mode changes.

The capstan sensor is a magnetoresistive Hall sensor that detects a magnetic field. The cylinder sensors are coil and magnet sensors. Each reel motor contains a high-resolution, optical-speed encoder.

---

## Read-After-Write

---

The read-after-write (RAW) technique provides a means of verifying that host data was written on the tape correctly by applying a read check immediately after writing the data to tape. The read check is a comparison of the actual signal quality versus a predetermined acceptable threshold level.

If a frame is identified as bad, it is rewritten later down the tape. The bad frame is not necessarily rewritten immediately. It can be rewritten after three, four or five other frames have been written. Any frame can be rewritten multiple times to provide for skipping over bad areas on the tape.

Excessive consecutive rewrites typically signal a degraded media condition; in these cases it is best to discontinue use of the tape in question and to continue with a new tape.

During a read or restore operation, the threshold level is reduced to maximize the likelihood that data can be successfully retrieved from tape. The combination of the elevated read threshold during write operations, and of the reduced threshold during read operations, ensures that data is written with the highest possible margin and that recorded data can be read or retrieved with the highest possible confidence.

---

## Media Recognition System (MRS)

---

The tape drive includes support for the media recognition system (MRS), which is unique to DDS products.

The MRS refers to a series of alternate opaque and clear stripes at the beginning of each tape. These stripes are used to classify the media as data- or computer-grade, rather than audio-grade, media.

Internal to the drive is a system of optical sensors and electronics to identify the MRS stripes to determine whether the tape is computer-grade media. The MRS capability can be enabled or disabled using the drive's DIP switch. When enabled, the drive does not allow any write operations to any non-MRS tape cartridges.

All DDS-4 (150 meter), DDS-3 (125 meter), DDS-2 (120 meter), and DAT 72 (170 meter) tape cartridges have MRS striping to signal that they are computer-grade media.

All DDS tape cartridges with the MRS striping either have the MRS logo, the MRS acronym or *media recognition system* printed on them to readily distinguish them from audio-grade media.

Audio-grade media is not suitable for data or computer backup purposes. Seagate DAT drives eject audio tapes.

---

## About the Data Cartridge

---

The tape drive is designed to use data-grade DDS/DAT cartridges, which comply with the specifications in the *3.81-mm Helical-Scan Digital Computer Tape Cartridge for Information Interchange, ANSI X3B5/89-156* standard. Seagate recommends Seagate-qualified, data-grade DDS/DAT cartridges to ensure optimal data integrity and reliability.

Seagate also recommends the use of a Seagate-qualified DDS head-cleaning cartridge (Model STDMCL or CDMCL).

**Note:** Proper maintenance of the drive requires that you use the DDS head-cleaning cartridge after every 50 hours of read/write operation and whenever the rectangular, green cartridge-in-place LED flashes during operation.

You can order both data and head-cleaning cartridges from Seagate. They are packaged in multiples of five.

These small (approximately 2 inches × 3 inches × 0.4 inch) cartridges house a magnetic tape that is 3.81 mm (0.150 inch) wide. The DDS cartridges are slightly bigger than a credit card. Figure 22 shows the key features of the DDS cartridge.



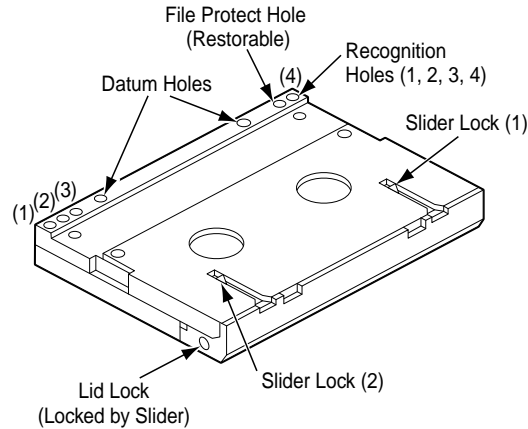

**Figure 22. DDS Drive Cartridge Design Features**

Qualified DDS cartridges are designed with specific write-protect, lid and other features for information interchange and are tested to comply with the ANSI DDS specifications.

The DAT 72 and DDS-4 drives also recognize all MRS cartridges when MRS is enabled. MRS cartridges have a series of alternate opaque and clear stripes at the beginning of the tape. These stripes classify the media as data-grade, rather than audio-grade media. Figure 23 shows the four recognition holes that allow the drive sensors to identify the type of tape, its magnetic thickness, and whether the tape is prerecorded, unrecorded or is a cleaning cartridge. Other cartridge features allow the drive to determine the cartridge in, BOT and EOT points.

The cartridge also provides for write protection so that existing data on the cartridge is not overwritten (See Figure 25). A write-protected cartridge allows the existing data to be read but does not allow new data to be written to the tape.

**Note:** A write-protected cartridge prevents the system log (in the system area) from being updated.

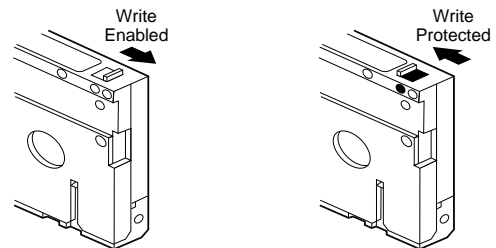

**Figure 23. Write-Protect Tab on the DDS Cartridge**



---

# Data Compression

---

# 6

---

## Introduction

---

### Overview

Typical data streams of text, graphics, software code or other forms of data contain repeated information of some sort, whether it is at the text level where you can readily recognize regular repetitions of a single word or at the binary level where the repetitions are in bits or bytes. Although most data is unique and random, the binary level data exhibits patterns of various sizes that repeat with varying degrees of regularity.

Storage efficiency is increased if the redundancies or repetitions in the data are removed before the data is recorded to tape. Data compression technology functions to significantly reduce or eliminate the redundancies in data before recording the information to tape. The compression increases the amount of data that can be stored on a finite medium and increases the overall storage efficiency of the system.

With data compression, the redundant information in a data stream is identified and then represented by codewords or symbols, which allow the same data to be recorded in a fewer number of bits. These symbols or codewords point back to the original data string, using fewer characters to represent the strings. Because these smaller symbols are substituted for the longer strings of data, more data can be stored in the same physical space.

Some important benefits result from data compression in DAT drives:

- The same amount of information can be stored on a smaller length of tape.
- Increased data density on a given length of tape.
- Performance can more closely parallel to that of high-transfer-rate computers.
- More information can be transferred in the same time interval.

## **Data Compression Considerations**

In an effective data-compression method, several factors are important:

- The amount of compression (measured by the *compression ratio*, which is a ratio that compares the amount of uncompressed data to the amount of compressed data and is obtained by dividing the size of the uncompressed data by the size of the compressed data)
- The speed with which data is compressed and decompressed in relation to the host transfer rate
- The types of data to be compressed
- The data integrity of the compressed data

The amount of compression possible in a data stream depends on factors such as the data pattern, the compression algorithm, the pattern repetition length, the pattern repetition frequency, the object size (block of information to be compressed) and the starting pattern chosen.

The transfer rate depends on factors such as the compression ratio, the drive buffer size, the host computer input/output (I/O) speed, the effective disc speeds of the host computer and the record lengths that the host computer transmits.

Data compression algorithms can be tailored to provide maximum compression on specific types of data. But because varying types of data are encountered in normal day-to-day operating circumstances, an effective data compression method for a tape drive must serve various data types. Additionally, the data compression method must *adapt* to different data types, automatically providing optimum handling for all types of data.

Considering these factors, Seagate engineers concluded:

The most effective data compression method must compress as much data as possible while assuring that

- The transfer rate of the host computer is not impeded.
- Adaptation is made to different types of data.
- Data integrity is maintained.

## **Hardware Compression**

If data compression is used in software on the host computer rather than in the hardware of the drive, you can slow down the transfer rate of the host because it must perform compression computations in addition to its regular computations. Also, any other host that wants to retrieve (decompress) the data must have the same software.

Hardware data compression (HDC) refers to the implementation of the DCLZ algorithm in the data compression engine, with the compression processing activity transparent to the host computer and the user.

Seagate's data compression engine is designed to provide a complete data compression system using the DCLZ algorithm. This IC provides support circuitry as well as the core DCLZ compression machine.

A more detailed description of the data compression engine is given later in this chapter.

## **Data Integrity**

There are various types of data-compression algorithms, but in this document they are divided into two basic types: *lossless* algorithms, such as DCLZ or ALDC, and *lossy* algorithms, such as those used in some consumer audio products.

Lossy algorithms drop out or lose some portion of repetitious data during the compression process to reduce the actual data bytes that are recorded to tape. The data lost during this process is lost forever and cannot be recovered. In consumer audio, this is not a problem because this method reduces required storage space and still provides better-than-analog recording and playback quality.

As you would expect, lossy algorithms are inappropriate for computer data storage of any type; hence the choice of lossless algorithms for computer data storage use.

Lossless algorithms are designed to compress data using a complex algorithm, ensuring that all data is compressed and recorded to tape and that all data can be decompressed and returned in the identical format as before. No bits are lost, and no data is compromised.

The DDS standards specify the use of the DCLZ algorithm, a lossless algorithm for data compression.

---

## **DCLZ Algorithm**

---

Within the computer industry, algorithms developed by Abraham Lempel and Jacob Ziv (enhanced later by Terry Welch) are popular, versatile and powerful compression methods. These LZ algorithms are basically of two types—LZ1, a sliding window method, and LZ2/LZW, a hashed directory method.

*LZ2* and *LZW* (Lempel-Ziv-Welch) are algorithms based on the *hashed dictionary* method; these algorithms offer an acceptable compromise between speed and compression ratio. This type of algorithm builds a symbol dictionary to represent strings as the data is processed and then looks up matching patterns in the dictionary. By monitoring the compression ratio in this type of algorithm, a new dictionary can be started when the ratio drops, indicating a change in the data type. This type of algorithm is responsive to changing data patterns while maintaining acceptable speed.

Although dependent on the particular implementation, the LZ2/LZW type of algorithm is generally faster than the LZ1 type because the dictionary structure promotes efficient searching.

The DCLZ algorithm used in the DDS tape drive is based on the LZ2/LZW algorithm type described earlier in this chapter. This algorithm has been approved by the US ANSI standards group and the European ECMA standards group. Both the DDS Manufacturers Group and QIC tape industry-standards committees accept DCLZ as an approved standard. Within the DDS Manufacturers Group, DCLZ is the only approved standard, ensuring complete interchange across all DDS drives and media.

### ***Simplified Compression Operation***

The following steps describe a simplified version of operation of the algorithm for compressing data:

1. From the current position in the input data stream, the algorithm fetches bytes (characters) until a string is formed that does not have a matching entry in the dictionary.
2. The codeword for the longest string that has an entry in the dictionary (all bytes except the last) is output.
3. A dictionary entry for the string formed in step 1 is created.
4. The current position is moved to the last byte of that string.
5. Steps 1 through 4 are repeated until the input data stream is completely processed.

The following table illustrates this simplified operation.

<b>Input Byte</b>	<b>Current String</b>	<b>Match</b>	<b>Build Entry</b>	<b>Output Code Value</b>
R	R	Y	—	—
I	RI	N	RI	(R)
—	I	Y	—	—
N	IN	N	IN	(I)
—	N	Y	—	—
T	NT	N	NT	(N)
—	T	Y	—	—
I	TI	N	TI	(T)
—	I	Y	—	—
N	IN	Y	—	—
T	INT	N	INT	(IN)
—	T	Y	—	—
I	TI	Y	—	—
N	TIN	N	TIN	(TI)
—	N	Y	—	—

## Dictionary

The dictionary is built and contained logically in external RAM and is not output as a distinct item. Rather, the decompressor recreates the dictionary to recreate the original data.

The dictionary allows up to 4,096 entries with each entry made up of:

- The unique string found in the data stream
- The codeword for that string

Codewords represent strings of up to 128 characters and are formed by adding a new character to an existing codeword. These codewords range from 9 through 12 bits in size and are assigned a number in the range 0 through 4,095.

These codewords are either control flags, encoded bytes or dictionary codes:

- **Control Flags, codewords 0 through 7:** These control flags are reserved codewords that flag specific conditions as follows:
  - 0 Dictionary frozen
  - 1 Dictionary reset
  - 2 Increment codeword size
  - 3 End of record (EOR)
  - 4–7 Reserved
- **Encoded bytes, codewords 8 through 263:** These encoded bytes represent single bytes of the input data stream and contain the values 0 through 255.

- **Dictionary codes, codewords 264 through 4,095:** The dictionary codes refer to dictionary entries and represent multiple bytes (a string of characters) in the input data stream. These codes are built as the input stream is processed. These codes are pointers to other locations and eventually end by pointing to one of the byte values 0 through 255. A linked chain is created that builds up a string of characters.

Each dictionary entry is 23 bits long and comprises a logical RAM address. The information is stored in 8-bit-wide static RAM chips that are 8K, 10K, or 16K by 22 bits. The structure of each dictionary entry is as follows:

- **Bits 0 through 7** contain the byte value of the entry.
- **Bits 8 through 19** contain the codeword that represents the entry or that points to a previous entry (encoded byte or dictionary code).
- **Bits 20 through 22** are condition flag bits.

Dictionary codewords range from 9 through 12 bits in length and correspond to dictionary entries from 0 through 4,095. These entries are divided as follows:

- First 512 entries are 9-bit codewords.
- Second 512 entries are 10-bit codewords.
- Next 1,024 entries are 11-bit codewords.
- Final 2,048 entries are 12-bit codewords.

### ***Simplified Decompression Operation***

The DCLZ algorithm requires that compression and decompression be tied together through:

- The compression and decompression processes (requires synchronization)
- The packing and unpacking of codewords into a byte stream (requires synchronization)

That is, decompression of the data does not begin at an arbitrary point; rather, it begins at a point where the dictionary is reset—known to be empty. This stipulation is vital because the dictionary is embedded in the codewords, which saves time and space as it is not recorded separately.

Likewise, the packing and unpacking processes require synchronization so that the compressed data is presented to the algorithm in the proper order.



The following steps describe a simplified version of the operation of the algorithm for decompressing data.

1. From a reset dictionary point, (which contains only control codes and encoded bytes) codewords are fetched from the input stream and looked up in the dictionary.
2. New dictionary codes are built by combining the previously received codewords. (The dictionary created during compression is recreated, guaranteeing that any codeword received is contained in the dictionary.)

Codewords that are encoded bytes are output directly. Codewords that are dictionary codes lead the algorithm through a series of bytes and codewords that point to other dictionary entries. Bytes are stacked until an encoded byte occurs; then, the stack is output.

The following table illustrates the reverse process of compression, showing a simplified decompression operation.

Input Code Value	Byte Value	Pointer	Root?	LIFO	Entry	Output Byte
(R)	R	—	Y	R	—	R
(I)	I	—	Y	I	RI	I
(N)	N	—	Y	N	IN	N
(T)	T	—	Y	T	NT	T
(IN)	N	(I)	N	N	—	—
—	I	—	Y	NI	TI	I
(TI)	I	(T)	N	I	—	—
—	T	—	Y	IT	INT	T
—	—	—	—	—	—	I
(N)	N	—	Y	N	TIN	N

The following table shows the dictionary based on the preceding table.

Codeword	Byte Value	Code Value (Pointer)
(RI)	I	(R)
(IN)	N	(I)
(NT)	T	(N)
(TI)	I	(T)
(INT)	T	(IN)
(TIN)	N	(TI)



