



RS/6000 7024 E Series

Service Guide

Fourth Edition (April 1997)

The following paragraph does not apply to the United Kingdom or any country where such provisions are inconsistent with local law: THIS PUBLICATION IS PROVIDED "AS IS" WITHOUT WARRANTY OF ANY KIND, EITHER EXPRESS OR IMPLIED, INCLUDING, BUT NOT LIMITED TO, THE IMPLIED WARRANTIES OF MERCHANTABILITY OR FITNESS FOR A PARTICULAR PURPOSE. Some states do not allow disclaimer of express or implied warranties in certain transactions, therefore, this statement may not apply to you.

This publication could include technical inaccuracies or typographical errors. Changes are periodically made to the information herein; these changes will be incorporated in new editions of the publication. The manufacturer may make improvements and/or changes in the product(s) and/or the program(s) described in this publication at any time, without notice.

It is possible that this publication may contain reference to, or information about, products (machines and programs), programming, or services that are not announced in your country. Such references or information must not be construed to mean that these products, programming, or services will be announced in your country. Any reference to a specific licensed program in this publication is not intended to state or imply that you can use only that licensed program. You can use any functionally equivalent program instead.

Requests for technical information about products should be made to your authorized reseller or marketing representative.

© International Business Machines Corporation 1995, 1997. All rights reserved.

Note to U.S. Government Users -- Documentation related to restricted rights -- Use, duplication or disclosure is subject to restrictions set forth in GSA ADP Schedule Contract with IBM Corp.

Contents

Communications Statements	vii
Federal Communications Commission (FCC) Statement	vii
European Union (EU) Statement	viii
International Electrotechnical Commission (IEC) Statement	viii
United Kingdom Telecommunications Safety Requirements	viii
Avis de conformité aux normes du ministère des Communications du Canada	ix
Canadian Department of Communications Compliance Statement	ix
VCCI Statement	ix
Radio Protection for Germany	x
Federal Communications Commission (FCC) Statement	xi
European Union (EU) Statement	xi
International Electrotechnical Commission (IEC) Statement	xii
United Kingdom Telecommunications Safety Requirements	xii
Avis de conformité aux normes du ministère des Communications du Canada	xii
Canadian Department of Communications Compliance Statement	xii
VCCI Statement	xiii
Radio Protection for Germany	xiv
Safety Notices	xv
Electrical Safety	xv
Laser Safety Information	xvii
About This Book	xix
ISO 9000	xix
Related Publications	xix
Chapter 1. Reference Information	1-1
System Unit Locations	1-1
System Board Locations	1-5
Specifications	1-7
Power Switch and Indicator LEDs	1-8
Power Cables	1-10
Service Inspection Guide	1-11
Chapter 2. Maintenance Analysis Procedures (MAPs)	2-1
Entry Map	2-1
Quick Entry MAP	2-2
MAP 1020: Problem Determination	2-7
MAP 1520: Power	2-12
MAP 1540: Minimum Configuration	2-18

Chapter 3. Error Code to FRU Index	3-1
Chapter 4. Loading the System Diagnostics	4-1
Chapter 5. System Management Services	5-1
Graphical System Management Services	5-2
Start Up	5-4
Test	5-5
Tools	5-7
Text-Based System Management Services Programs	5-11
Select Boot Devices	5-12
Test the Computer	5-13
Utilities	5-14
ASCII Terminal System Management Services Programs	5-16
Select Boot Devices	5-17
Test the Computer	5-18
Utilities	5-19
Chapter 6. Firmware	6-1
Boot Block	6-1
Firmware Core	6-2
Virtual Disk	6-2
Password Design Description	6-6
Firmware Flash Update Design	6-7
Power On Self Test (POST)	6-9
Post Indicators	6-11
Chapter 7. Removal and Replacement Procedures	7-1
Handling Static-Sensitive Devices	7-2
Acclimation	7-2
Covers	7-3
Power Supply	7-7
Media Drive in Bays 3 through 8	7-9
Diskette Drive and Lower Hard Disk Drive	7-12
Adapters	7-15
Memory Modules	7-17
CPU Card	7-22
Service Processor	7-23
Battery	7-25
Fan and Speaker Assembly	7-27
Operator Panel Display	7-28
System Board	7-31
Chapter 8. Parts Information	8-1

Power Cables	8-5
Appendix A. Firmware Checkpoint Three-Digit Codes	A-1
Index	X-1

Communications Statements

The following statement applies to this product. The statement for other products intended for use with this product appears in their accompanying manuals.

If Feature Codes 2743, 3615, 6218, 8130 or 8134 are NOT installed, this system complies with the limits for a Class B digital device, pursuant to Part 15 of the FCC Rules.

Federal Communications Commission (FCC) Statement

Note: The *IBM RS/6000 7024 E Series Server* has been tested and found to comply with the limits for a Class B digital device, pursuant to Part 15 of the FCC Rules. These limits are designed to provide reasonable protection against harmful interference in a residential installation. This equipment generates, uses, and can radiate radio frequency energy and, if not installed and used in accordance with the instructions, may cause harmful interference to radio communications. However, there is no guarantee that interference will not occur in a particular installation. If this equipment does cause harmful interference to radio or television reception, which can be determined by turning the equipment off and on, the user is encouraged to try to correct the interference by one or more of the following measures:

- Reorient or relocate the receiving antenna.
- Increase the separation between the equipment and receiver.
- Connect the equipment into an outlet on a circuit different from that to which the receiver is connected.
- Consult an authorized dealer or service representative for help.

Properly shielded and grounded cables and connectors must be used in order to meet FCC emission limits. Proper cables and connectors are available from authorized dealers. Neither the provider nor the manufacturer are responsible for any radio or television interference caused by using other than recommended cables and connectors or by unauthorized changes or modifications to this equipment. Unauthorized changes or modifications could void the user's authority to operate the equipment.

This device complies with Part 15 of the FCC Rules. Operation is subject to the following two conditions: (1) this device may not cause harmful interference, and (2) this device must accept any interference received, including interference that may cause undesired operation.

Responsible Party:

International Business Machines Corporation

Old Orchard Road
Armonk, New York 10504
Telephone: (919) 543-2193

European Union (EU) Statement

This product is in conformity with the protection requirements of EU Council Directive 89/336/EEC on the approximation of the laws of the Member States relating to electromagnetic compatibility. The manufacturer cannot accept responsibility for any failure to satisfy the protection requirements resulting from a non-recommended modification of the product, including the fitting of option cards supplied by third parties. Consult with your dealer or sales representative for details on your specific hardware.

This product has been tested and found to comply with the limits for Class B Information Technology Equipment according to CISPR 22 / European Standard EN 55022. The limits for Class B equipment were derived for typical residential environments to provide reasonable protection against interference with licensed communication devices.

International Electrotechnical Commission (IEC) Statement

This product has been designed and built to comply with IEC Standard 950.

United Kingdom Telecommunications Safety Requirements

This equipment is manufactured to the International Safety Standard EN60950 and as such is approved in the UK under the General Approval Number NS/G/1234/J/100003 for indirect connection to the public telecommunication network.

The network adapter interfaces housed within this equipment are approved separately, each one having its own independent approval number. These interface adapters, supplied by the manufacturer, do not use or contain excessive voltages. An excessive voltage is one which exceeds 70.7 V peak ac or 120 V dc. They interface with this equipment using Safe Extra Low Voltages only. In order to maintain the separate (independent) approval of the manufacturer's adapters, it is essential that other optional cards, not supplied by the manufacturer, do not use main voltages or any other excessive voltages. Seek advice from a competent engineer before installing other adapters not supplied by the manufacturer.

Avis de conformité aux normes du ministère des Communications du Canada

Cet appareil numérique de la classe B respecte toutes les exigences du Règlement sur le matériel brouilleur du Canada.

Canadian Department of Communications Compliance Statement

This Class B digital apparatus meets the requirements of the Canadian Interference-Causing Equipment Regulations.

VCCI Statement

この装置は、第二種情報装置（住宅地域又はその隣接した地域において使用されるべき情報装置）で住宅地域での電波障害防止を目的とした情報処理装置等電波障害自主規制協議会（VCCI）基準に適合しております。

しかし、本装置をラジオ、テレビジョン受信機に近接してご使用になると、受信障害の原因となることがあります。

取扱説明書に従って正しい取り扱いをして下さい。

The following is a summary of the VCCI Japanese statement in the box above.

This equipment is in the Class 2 category (information equipment to be used in a residential area or an adjacent area thereto) and conforms to the standards set by the Voluntary Control Council For Interference by Data Processing Equipment and Electronic Office Machines aimed at preventing radio interference in such residential area.

When used near a radio or TV receiver, it may become the cause of radio interference.

Read the instructions for correct handling.

Radio Protection for Germany

Dieses Gerät ist berechtigt in Übereinstimmung mit dem deutschen EMVG vom 9.Nov.92 das EG-Konformitätszeichen zu führen.

Der Aussteller der Konformitätserklärung ist die IBM Germany.

Dieses Gerät erfüllt die Bedingungen der EN 55022 Klasse B.

If Feature Codes 2743, 3615, 6218, 8130 or 8134 are installed, this system complies with the limits for a Class A digital device, pursuant to Part 15 of the FCC Rules.

Federal Communications Commission (FCC) Statement

Note: This equipment has been tested and found to comply with the limits for a Class A digital device, pursuant to Part 15 of the FCC Rules. These limits are designed to provide reasonable protection against harmful interference when the equipment is operated in a commercial environment. This equipment generates, uses, and can radiate radio frequency energy and, if not installed and used in accordance with the instruction manual, may cause harmful interference to radio communications. Operation of this equipment in a residential area is likely to cause harmful interference in which case the user will be required to correct the interference at his own expense.

Properly shielded and grounded cables and connectors must be used in order to meet FCC emission limits. Neither the provider nor the manufacturer are responsible for any radio or television interference caused by using other than recommended cables and connectors or by unauthorized changes or modifications to this equipment. Unauthorized changes or modifications could void the user's authority to operate the equipment.

This device complies with Part 15 of the FCC Rules. Operation is subject to the following two conditions: (1) this device may not cause harmful interference, and (2) this device must accept any interference received, including interference that may cause undesired operation.

European Union (EU) Statement

This product is in conformity with the protection requirements of EU Council Directive 89/336/EEC on the approximation of the laws of the Member States relating to electromagnetic compatibility. The manufacturer cannot accept responsibility for any failure to satisfy the protection requirements resulting from a non-recommended modification of the product, including the fitting of option cards supplied by third parties. Consult with your dealer or sales representative for details on your specific hardware.

This product has been tested and found to comply with the limits for Class A Information Technology Equipment according to CISPR 22 / European Standard EN 55022. The limits for Class A equipment were derived for commercial and industrial environments to provide reasonable protection against interference with licensed communication equipment.

Attention: This is a Class A product. In a domestic environment this product may cause radio interference in which case the user may be required to take adequate measures.

International Electrotechnical Commission (IEC) Statement

This product has been designed and built to comply with IEC Standard 950.

United Kingdom Telecommunications Safety Requirements

This equipment is manufactured to the International Safety Standard EN60950 and as such is approved in the UK under the General Approval Number NS/G/1234/J/100003 for indirect connection to the public telecommunication network.

The network adapter interfaces housed within this equipment are approved separately, each one having its own independent approval number. These interface adapters, supplied by the manufacturer, do not use or contain excessive voltages. An excessive voltage is one which exceeds 70.7 V peak ac or 120 V dc. They interface with this equipment using Safe Extra Low Voltages only. In order to maintain the separate (independent) approval of the manufacturer's adapters, it is essential that other optional cards, not supplied by the manufacturer, do not use main voltages or any other excessive voltages. Seek advice from a competent engineer before installing other adapters not supplied by the manufacturer.

Avis de conformité aux normes du ministère des Communications du Canada

Cet appareil numérique de la classe A respecte toutes les exigences du Règlement sur le matériel brouilleur du Canada.

Canadian Department of Communications Compliance Statement

This Class A digital apparatus meets the requirements of the Canadian Interference–Causing Equipment Regulations.

VCCI Statement

電波障害自主規制 届出装置の記述

この装置は、第一種情報装置（商工業地域において使用されるべき情報装置）で商工業地域での電波障害防止を目的とした情報処理装置等電波障害自主規制協議会（VCCI）基準に適合しております。

従って、住宅地域またはその隣接した地域で使用すると、ラジオ、テレビジョン受信機等に受信障害を与えることがあります。

取扱説明書に従って正しい取り扱いをしてください。

The following is a summary of the VCCI Japanese statement in the box above.

This equipment is in the Class 1 category (information equipment to be used in commercial and/or industrial areas) and conforms to the standards set by the Voluntary Control Council For Interference by Data Processing Equipment and Electronic Office Machines aimed at preventing radio interference in commercial and/or industrial areas.

Consequently, when used in a residential area or in an adjacent area thereto, radio interference may be caused to radios and TV receivers, etc.

Read the instructions for correct handling. VCCI-1.

Radio Protection for Germany

Dieses Gerät ist berechtigt in Übereinstimmung mit dem deutschen EMVG vom 9.Nov.92 das EG–Konformitätszeichen zu führen.

Der Aussteller der Konformitätserklärung ist die IBM Germany.

Dieses Gerät erfüllt die Bedingungen der EN 55022 Klasse A. Für diese von Geräten gilt folgende Bestimmung nach dem EMVG:

Geräte dürfen an Orten, für die sie nicht ausreichend entstört sind, nur mit besonderer Genehmigung des Bundesministers für Post und Telekommunikation oder des Bundesamtes für Post und Telekommunikation betrieben werden. Die Genehmigung wird erteilt, wenn keine elektromagnetischen Störungen zu erwarten sind.

(Auszug aus dem EMVG vom 9.Nov.92, Para.3, Abs.4)

Hinweis

Dieses Genehmigungsverfahren ist von der Deutschen Bundespost noch nicht veröffentlicht worden.

Safety Notices

A *danger* notice indicates the presence of a hazard that has the potential of causing death or serious personal injury.

A *caution* notice indicates the presence of a hazard that has the potential of causing moderate or minor personal injury.

Electrical Safety

Observe the following safety instructions any time you are connecting or disconnecting devices attached to the workstation.

DANGER

An electrical outlet that is not correctly wired could place hazardous voltage on metal parts of the system or the devices that attach to the system. It is the responsibility of the customer to ensure that the outlet is correctly wired and grounded to prevent an electrical shock.

Before installing or removing signal cables, ensure that the power cables for the system unit and all attached devices are unplugged.

When adding or removing any additional devices to or from the system, ensure that the power cables for those devices are unplugged before the signal cables are connected. If possible, disconnect all power cables from the existing system before you add a device.

Use one hand, when possible, to connect or disconnect signal cables to prevent a possible shock from touching two surfaces with different electrical potentials.

During an electrical storm, do not connect cables for display stations , printers, telephones, or station protectors for communication lines.

CAUTION:

This product is equipped with a three-wire power cable and plug for the user's safety. Use this power cable with a properly grounded electrical outlet to avoid electrical shock.

DANGER

To prevent electrical shock hazard, disconnect the power cable from the electrical outlet before relocating the system.

Laser Safety Information

The optical drive in this system unit is a laser product. The optical drive has a label that identifies its classification. The label, located on the drive, is shown below.

CLASS 1 LASER PRODUCT LASER KLASSE 1 LUOKAN 1 LASERLAITE APPAREIL À LASER DE CLASSE 1 IEC 825:1984 CENELEC EN 60 825:1991

The optical drive in this system unit is certified in the U.S. to conform to the requirements of the Department of Health and Human Services 21 Code of Federal Regulations (DHHS 21 CFR) Subchapter J for Class 1 laser products. Elsewhere, the drive is certified to conform to the requirements of the International Electrotechnical Commission (IEC) 825 (1st edition 1984) and CENELEC EN 60 825:1991 for Class 1 laser products.



CAUTION:

A class 3 laser is contained in the device. Do not attempt to operate the drive while it is disassembled. Do not attempt to open the covers of the drive as it is not serviceable and is to be replaced as a unit.

Class 1 laser products are not considered to be hazardous. The optical drive contains internally a Class 3B gallium-arsenide laser that is nominally 30 milliwatts at 830 nanometers. The design incorporates a combination of enclosures, electronics, and redundant interlocks such that there is no exposure to laser radiation above a Class 1 level during normal operation, user maintenance, or servicing conditions.

About This Book

This book provides maintenance information that is specific to the system unit, adapters, and devices that do not have their own service information. It also contains Maintenance Analysis Procedures (MAPs) that are not common to other systems.

MAPs that are common to all systems are contained in the *IBM RS/6000 Diagnostic Information for Multiple Bus Systems*.

This book is used by the service technician to repair system failures. This book assumes that the service technician has had training on the system unit.

ISO 9000

ISO 9000 registered quality systems were used in the development and manufacturing of this product.

Related Publications

The following publications are available for purchase:

- The *IBM RS/6000 7024 E Series User's Guide* contains information to help users set up, install options, configure, modify, and solve minor problems.
- The *IBM RS/6000 Diagnostic Information for Multiple Bus Systems* contains common diagnostic procedures, error codes, service request numbers, and failing function codes. This manual is intended for trained service technicians.
- The *IBM RS/6000 Adapters, Devices, and Cable Information for Multiple Bus Systems* contains information about adapters, external devices, and cabling. This manual is intended to supplement information found in the *IBM RS/6000 Diagnostic Information for Multiple Bus Systems*.
- The *Site and Hardware Planning Information* contains information to help you plan your installation.

Chapter 1. Reference Information

System Unit Locations

Front View with Door Open

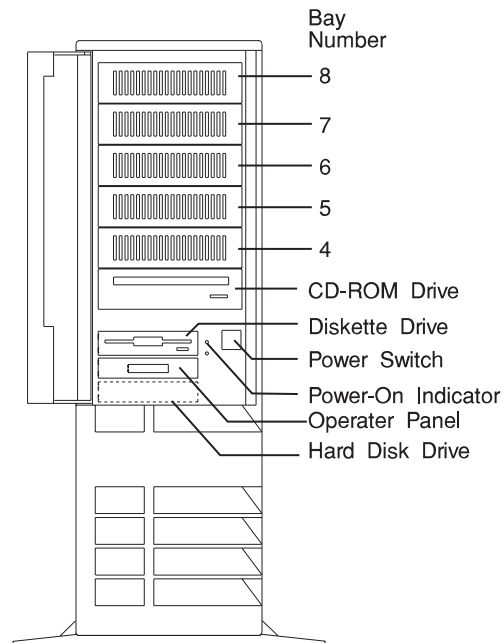

Rear View

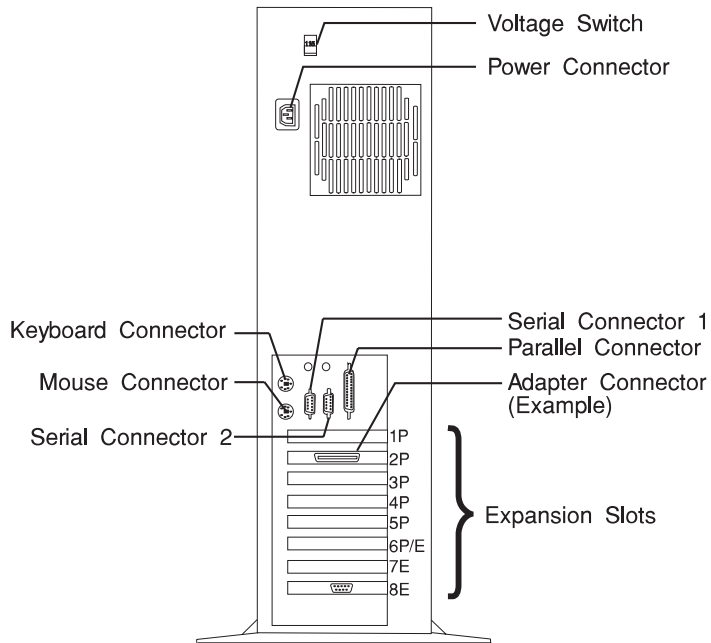

Side View with Covers Removed

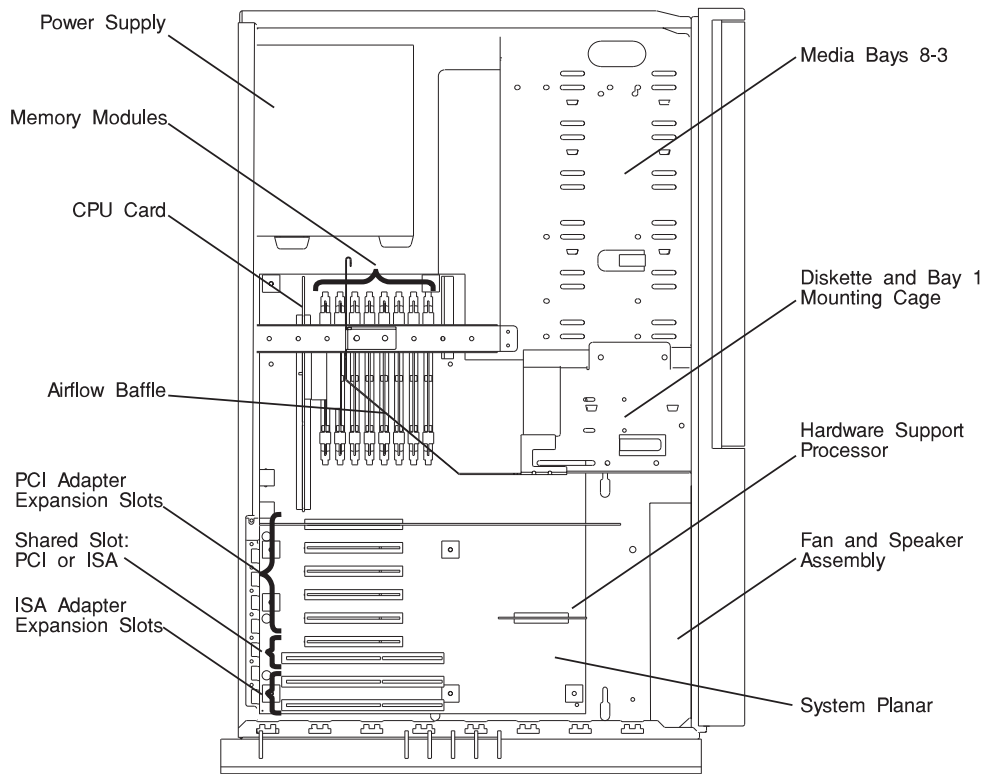

Recommended SCSI IDs

Early Systems

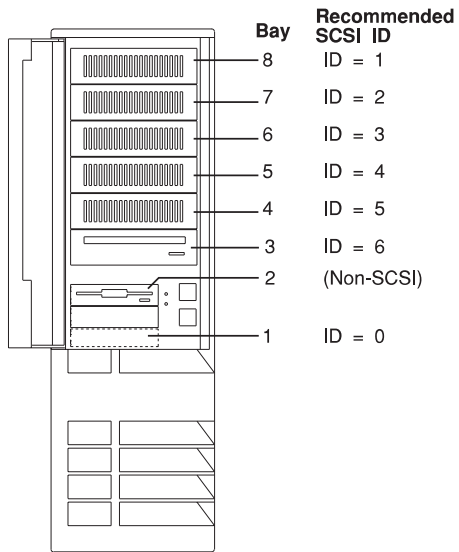

Current Systems

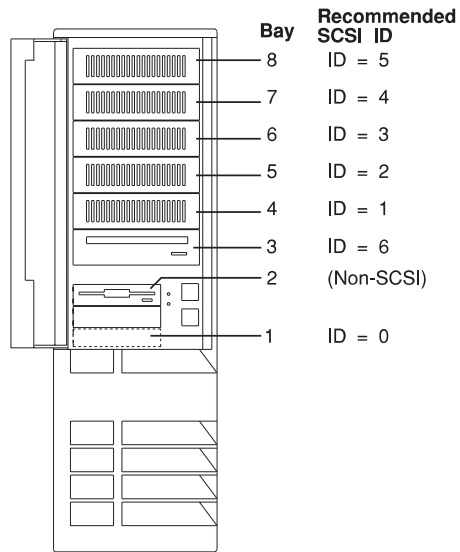

System Board Locations

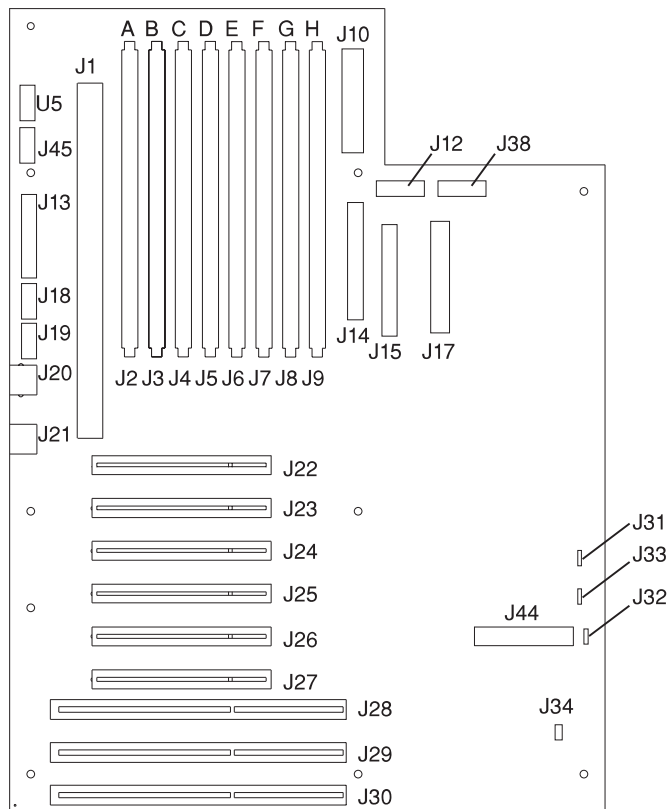

- J1** CPU Card Connector
- J2 through J9** Memory Module (DIMM) Connectors
- J10** Power Supply (P1 and P2)
- J12** Power Supply
- J13** Parallel Port Connector
- J14** 16-bit SCSI Connector (16-bit and 8-Bit SCSI connectors are mutually exclusive)
- J15** 8-bit SCSI Connector (8-bit and 16-Bit SCSI connectors are mutually exclusive)
- J17** Diskette Connector
- J18** Serial Port 1 Connector

J19	Serial Port 2 Connector
J20	Keyboard Connector
J21	Mouse
J22 through 27	PCI Adapter Connectors
J28 through J30	ISA Adapter Connectors
J31	Disk Drive LED Connector
J32	Power LED Connector
J33	Speaker Connector
J34	Fan Connector
J38	Power Supply
J44	Hardware Service Processor Connector
J45	Operator Panel Connector
U5	VPD Module

Specifications

The mechanical packaging, cooling, power supply, and environmental requirements for the server is shown in the following:

Dimensions

Height - 648 mm (25.5 inches)

Depth - 450 mm (17.7 inches)

Width - 315 mm (12.4 inches)

Weight - Configuration dependent

Operating Environment - Class B

Temperature - 16° to 32°C (60° to 90°F)

Humidity - 8% to 80% noncondensing

Maximum Altitude - 2135 m (7000 feet)

Power Source Loading

0.32 kVA

Power Supply

300 watts

Operating Voltage (Selectable)

100 to 125V ac; 50 to 60 Hz

200 to 240V ac; 50 to 60 Hz

Heat Output (Maximum)

1020 BTU/hr

Power Switch and Indicator LEDs

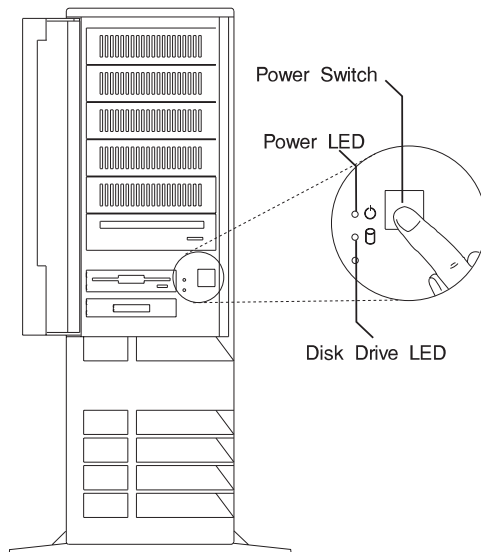

The power switch and light-emitting diodes (LEDs) on the front of your server allow you control power to the server, observe system power status, and observe disk activity.

These features also have other built-in capabilities to assist you in diagnosing system problems and observing system status:

- As soon as the system unit is connected to a power source, the power LED will begin blinking slowly (about 2 flashes per second) to indicate that Standby Power is on, even though the system unit is **not** powered on or running.
- When the system unit is turned on by pressing the power switch, the power LED lights steadily.

If the operating system is loaded and running, a memory dump of system information can be requested.

- To enable this function, the **sysdumpdev -K** command must be executed before an error condition exists.
- To request a memory dump, press and hold the power switch for longer than two seconds. Requesting a memory dump directs the operating system to save system information to a predefined file before turning off the system. This feature can be used to assist in recovery from system problems.

- When a memory dump has been requested the power LED will blink quickly (about 10 flashes per second) to indicate that the dump has been started. This blinking will cease after about a minute whether or not the dump is complete, and the LED will return to its steady, lit state until the system turns off or reboots when the dump is complete.
- The memory dump file can be viewed by entering the the operating system command:
sysdumpdev -L

The disk drive LED lights whenever the hard disk drives within the server are being used.

The disk drive LED also provides basic system diagnostic information:

- If no memory can be found as the system boots, the disk drive LED lights and the system stops the boot process.
- If an error is detected in the firmware boot program, this LED lights and the system stops, and the diskette activity LED begins blinking. This condition indicates that the system is requesting a Firmware Recovery Diskette, which should be made to facilitate resolution of system problems. For instructions on creating a Firmware Recovery Diskette, see Chapter 5, "System Management Services" on page 5-1.

Power Cables

To avoid electrical shock, a power cable with a grounded attachment plug is provided. Use only properly grounded outlets.

Power cables used in the United States and Canada are listed by Underwriter's Laboratories (UL) and certified by the Canadian Standards Association (CSA). These power cords consist of:

- Electrical cables, Type SVT or SJT.
- Attachment plugs complying with National Electrical Manufacturers Association (NEMA) 5-15P. That is:

"For 115 V operation, use a UL listed cable set consisting of a minimum 18 AWG, Type SVT or SJT three-conductor cord a maximum of 15 feet in length and a parallel blade, grounding type attachment plug rated at 15 A, 125 V."

"For 230 V operation in the United States use a UL listed cable set consisting of a minimum 18 AWG, Type SVT or SJT three-conductor cable a maximum of 15 feet in length, and a tandem blade, grounding type attachment plug rated at 15 A, 250 V."

- Appliance couplers complying with International Electrotechnical Commission (IEC) Standard 320, Sheet C13.

Power cables used in other countries consist of the following:

- Electrical cables, Type HD21.
- Attachment plugs approved by the appropriate testing organization for the specific countries where they are used.

"For units set at 230 V (outside of U.S.): use a cable set consisting of a minimum 18 AWG cable and grounding type attachment plug rated 15 A, 250 V. The cable set should have the appropriate safety approvals for the country in which the equipment will be installed and should be marked HAR'."

Service Inspection Guide

Perform a service inspection on the system when:

The system is inspected for a maintenance agreement.

- Service is requested and service has not recently been performed.
- An alterations and attachments review is performed.
- Changes have been made to the equipment that may affect the safe operation of the equipment.
- External devices with their own power cables have those cables attached.

If the inspection indicates an unacceptable safety condition, the condition must be corrected before anyone can service the machine.

Note: The correction of any unsafe condition is the responsibility of the owner of the system.

Perform the following checks:

1. Check the covers for sharp edges and for damage or alterations that expose the internal parts of the system unit.
2. Check the covers for proper fit to the system unit. They should be in place and secure.
3. Gently rock the system unit from side to side to determine if it is steady.
4. Set the power switch of the system unit to Off.
5. Remove the covers.
6. Check for alterations or attachments. If there are any, check for obvious safety hazards such as broken wires, sharp edges, or broken insulation.
7. Check the internal cables for damage.
8. Check for dirt, water, and any other contamination within the system unit.
9. Check the voltage label on the back of the system unit to ensure that it matches the voltage at the outlet.
10. Check the external power cable for damage.
11. With the external power cable connected to the system unit, check for 0.1 ohm or less resistance between the ground lug on the external power cable plug and the metal frame.
12. Perform the following checks on each device that has its own power cables:
 - a. Check for damage to the power cord.

b. Check for the correct grounded power cable.

c. With the external power cable connected to the device, check for 0.1 ohm or less resistance between the ground lug on the external power cable the metal frame of the device.

13. Install the covers.

Chapter 2. Maintenance Analysis Procedures (MAPs)

Entry Map

Use the following table to determine your starting point.

Note: When possible, run Online Diagnostics in Service Mode. Online Diagnostics perform additional functions, compared to Standalone Diagnostics. This will ensure that the error state of the system is captured in NVRAM for your use in fixing the problem. The AIX error log and SMIT are only available when running online diagnostics.

Symptom	Starting Point
You have a problem that does not prevent the system from booting.	Go to the Fast Path MAP in the <i>IBM RS/6000 Diagnostic Information for Multiple Bus Systems</i> .
You do not have a symptom.	Go to MAP 0020 in the <i>IBM RS/6000 Diagnostic Information for Multiple Bus Systems</i> .
You have an SRN.	Go to the Fast Path MAP in the <i>IBM RS/6000 Diagnostic Information for Multiple Bus Systems</i> .
The system stops and a 3-digit number is displayed in the operator panel display.	Record SRN 101-xxx, where xxx is the 3-digit number displayed in the operator panel display, then go to the Fast Path MAP in the <i>IBM RS/6000 Diagnostic Information for Multiple Bus Systems</i> .
You have an 8-digit error code.	Go to "Quick Entry MAP" on page 2-2.
The system will not boot.	Go to "Quick Entry MAP" on page 2-2.

Quick Entry MAP

Quick Entry MAP Table of Contents

Problem Description	Page No.
Service Actions	2-3
8-Digit Error Codes	2-3
System Stops With an 8-Digit Number Displayed	2-3
There Appears to be a Display Problem (Distortion, Blurring,Etc.)	2-3
Power and Cooling Problems	2-3
Intermittent Memory Problems	2-4
Other Symptoms	2-4
Miscellaneous Problems	2-6
Flashing 888 in Operator Panel Display	2-6

Symptoms	What You Should Do
Service Actions	
You have parts to exchange or a corrective action to perform.	<ol style="list-style-type: none"> 1. Go to the <i>Removal and Replacement Procedures</i>. 2. Go to the <i>Repair Checkout Procedure</i> in the <i>IBM RS/6000 Diagnostic Information for Multiple Bus Systems</i>.
You need to verify that a part exchange or corrective action corrected the problem.	Go to the <i>Repair Checkout Procedure</i> in the <i>IBM RS/6000 Diagnostic Information for Multiple Bus Systems</i> .
You need to verify correct system operation.	Go to the <i>System Checkout Procedure</i> in the <i>IBM RS/6000 Diagnostic Information for Multiple Bus Systems</i> .
8-Digit Error Codes	
You have an 8-Digit Error Code.	Look up "8-Digit Error" in Chapter 3, "Error Code to FRU Index" and do the listed action.
System Stops With a 8-Digit Number Displayed	
The system stops with an 8-Digit Error Code displayed when booting.	<ol style="list-style-type: none"> 1. Record the 8-Digit Error Code. 2. Look up "8-Digit Error" in Chapter 3, "Error Code to FRU Index" and do the listed action.
There Appears to be a Display Problem (Distortion, Blurring, Etc.)	
A long beep followed immediately by a short beep is heard.	<p>A display adapter problem is indicated.</p> <ol style="list-style-type: none"> 1. Replace the graphics adapter.
All other display problems.	<ol style="list-style-type: none"> 1. If using a graphics display, go to the <i>Problem Determination Procedures</i> for the display. 2. If you do not find a problem then replace the display adapter. 3. If the problem is with the ASCII terminal go to the <i>Problem Determination Procedures</i> for the terminal. 4. If you do not find a problem then replace the system board.
Power and Cooling Problems	
You cannot power on the system	Go to "MAP 1520: Power" on page 2-12.
The power light does not come on, or stay on.	Go to "MAP 1520: Power" on page 2-12.

Symptoms	What You Should Do
Intermittent Memory Problems	
"Loop on Memory Test" is provided by SMS. It can be used to test for intermittent memory problems.	Refer to Chapter 5, "System Management Services" on page 5-1 for more information.
Other Symptoms	
The system stops with the disk activity indicator LED OFF and no beep occurred.	<p>The processor POST failed or did not execute. There may be a problem with the CPU card or system board.</p> <ol style="list-style-type: none"> 1. Replace the CPU card. If the problem still exists after replacing the CPU card, go to "MAP 1540: Minimum Configuration" on page 2-18.
The system stops with the disk activity indicator LED ON continuously and no beep occurred.	<p>No good memory could be found.</p> <ol style="list-style-type: none"> 1. If there is only one memory module installed, replace it. 2. If there is more than one memory module installed, go to "MAP 1540: Minimum Configuration" on page 2-18.
The system stops after issuing one short beep and the disk activity indicator LED is ON.	<p>Less than 3MB of memory tested good.</p> <ol style="list-style-type: none"> 1. If there is only one memory module installed, replace it. 2. If there is more than one memory module installed, go to "MAP 1540: Minimum Configuration" on page 2-18.
The disk activity indicator LED is blinking rapidly.	The flash EPROM data is corrupted. The recovery procedure for the flash EPROM should be executed.
The system stops and POST indicators are displayed.	<ol style="list-style-type: none"> 1. Use "MAP 1540: Minimum Configuration" on page 2-18 to isolate the problem.
The system stops and the message "STARTING SOFTWARE PLEASE WAIT..." is displayed.	Go to "MAP 1020: Problem Determination" on page 2-7.

Symptoms	What You Should Do
<p>The System Management Services menu is displayed.</p>	<p>The device or media you are attempting to boot from may be faulty.</p> <ol style="list-style-type: none"> 1. Check the SMS error log for any errors. To check the error log: <ul style="list-style-type: none"> • Choose tools • Choose error log • If an error is logged, check the time stamp. • If the error was logged during the current boot attempt, record it. • Look up the error in Chapter 3, "Error Code to FRU Index" and do the listed action. • If no recent error is logged in the error log, continue to the next step below. 2. Try to boot from an alternate boot device connected to the same controller as the original boot device. If the boot succeeds, replace the original boot device (for removable media devices try the media first). 3. Go to "MAP 1540: Minimum Configuration" on page 2-18.
<p>The system will not respond to the password being entered or the system login prompt is displayed when booting in service mode.</p>	<p>The keyboard or it's controller may be faulty.</p> <ol style="list-style-type: none"> 1. If entering the password from the keyboard which is attached to the system, replace the keyboard. If replacing the keyboard does not fix the problem, replace the system board. 2. If entering the password from a keyboard which is attached to a ASCII terminal, suspect the ASCII terminal. Use the Problem Determination Procedures for the terminal. Replace the system board if these procedures do not reveal a problem.
<p>A short and long beep are heard. However, nothing is displayed.</p>	<ol style="list-style-type: none"> 1. If using a graphic display, go to the <i>Problem Determination Procedures</i> for the display. 2. If you do not find a problem then replace the display adapter. 3. Go to "MAP 1540: Minimum Configuration" on page 2-18.
<p>Only a short beep, disk activity indicator LED is OFF, and no POST indicators are displayed.</p>	<p>Go to "MAP 1540: Minimum Configuration" on page 2-18.</p>

Symptoms	What You Should Do
Miscellaneous Problems	
You suspect a cable problem.	See the <i>IBM RS/6000 Adapters, Devices, and Cable Information for Multiple Bus Systems</i> .
Flashing 888	
Flashing 888 in Operator Panel Display	Go to the Fast Path MAP in the <i>IBM RS/6000 Diagnostic Information for Multiple Bus Systems</i> .
You Cannot Find the Symptom in this Table	
All other problems.	Go to "MAP 1020: Problem Determination" on page 2-7.

MAP 1020: Problem Determination

Purpose of This MAP

Use this MAP to get a eight-digit error code if you were not provided with one by the customer or you are unable to load diagnostics. If you are able to load the diagnostics, go to MAP 0020 in the *IBM RS/6000 Diagnostic Information for Multiple Bus Systems*.

Be prepared to record code numbers and use those numbers in the course of analyzing a problem. Go to "Step 1020-1."

Step 1020-1

The following steps analyze a failure to load the diagnostic programs.

Note: You will be asked questions regarding whether the system produced a beep or beeps. You will also be asked to perform certain actions based on displayed POST indicators. Please be observant of these conditions.

1. Turn the power off.
2. Turn the power on.
3. Insert the diagnostic CD-ROM disc into the CD-ROM drive.
4. If the keyboard POST indicator appears, press F5 on the direct attached keyboard or number 5 on an ASCII terminal.

5. Enter any requested passwords.
6. Follow displayed instructions until diagnostic operating instructions are displayed or the system appears to stop.
7. Find your symptom in the following table; then follow the instructions given in the Action column.

Symptom	Action
The disk activity indicator LED is blinking rapidly.	The flash EPROM data is corrupted. The recovery procedure for the flash EPROM should be executed.
The system stops with a prompt to enter a password.	Enter the password. You will not be allowed to continue until a correct password has been entered. When you have entered a valid password go to the beginning of this table and wait for one of the other conditions to occur.
The diagnostic operating instructions are displayed.	Go to MAP 0020 in the <i>IBM RS/6000 Diagnostic Information for Multiple Bus Systems</i> .
The power good LED does not come on or does not stay on.	Go to "MAP 1520: Power" on page 2-12.
The system stops with an eight-digit error code(s) displayed on the console.	Record the error code(s), then go to "Step 1020-3" on page 2-10.
The system login prompt is displayed.	<p>You may not have pressed the correct key or you may not have pressed the key soon enough when you were to indicate a Service Mode IPL of the diagnostic programs. If this was the case start over at the beginning of this Step.</p> <p>Note: Perform the systems shutdown procedure before turning off the system.</p> <p>If you are sure you pressed the correct key in a timely manner, go to "Step 1020-2" on page 2-10.</p>
The system unit produces one long beep immediately followed by a short beep.	Record error code M0GA0000, then go to "Step 1020-3" on page 2-10.
A continuous beep is heard from the system unit.	Record error code M0SPK000, then go to "Step 1020-3" on page 2-10.
A short and long beep are heard. However, nothing is displayed.	<ol style="list-style-type: none"> 1. If using a graphic display, go to the <i>Problem Determination Procedures</i> for the display. 2. If you do not find a problem then replace the display adapter. 3. Go to "MAP 1540: Minimum Configuration" on page 2-18.
The system appears to be stopped, the disk activity indicator LED is OFF and a beep was NOT heard from the system unit.	Record error code M0CPU000, then go to "Step 1020-3" on page 2-10.

Symptom	Action
Only a short beep, disk activity indicator LED is OFF, and no POST indicators are displayed.	Go to "MAP 1540: Minimum Configuration" on page 2-18.
The system appears to be stopped and the disk activity indicator LED is ON continuously and a beep was NOT heard from the system unit.	Record error code M0MEM000, then go to "Step 1020-3" on page 2-10.
The system appears to be stopped and the disk activity indicator LED is ON continuously and a beep was heard from the system unit.	Record error code M0MEM001, then go to "Step 1020-3" on page 2-10.
The System Management Services menu is displayed.	Go to "Step 1020-4" on page 2-11.
The system stops and POST indicators are displayed.	Go to "MAP 1540: Minimum Configuration" on page 2-18.
The diagnostics are loaded and there was no beep heard from the system unit during the IPL sequence.	Record error code M0SPK001, then go to "Step 1020-3" on page 2-10.
The system does not respond when the password is entered.	Go to "Step 1020-2" on page 2-10.
The system stops and the message "STARTING SOFTWARE PLEASE WAIT..." is displayed or only a cursor is displayed.	Go to "MAP 1540: Minimum Configuration" on page 2-18.
The system stopped and a POST indicator is displayed on the system console and an eight-digit error code is not displayed.	<p>If the POST indicator represents:</p> <ul style="list-style-type: none"> • a keyboard, record error code M0KBD000. • boot disk, record error code M0HD0000. • memory, record error code M0MEM002. • a diskette drive, record error code M0FD0000. • SCSI, record error code M0CON000. <p>Go to "Step 1020-3" on page 2-10.</p>

Step 1020-2

There is a problem with the keyboard.

Find the type of keyboard you are using in the following table; then follow the instructions given in the Action column.

Keyboard Type	Action
Type 101 keyboard (U.S.). Identify by the size of the Enter key. The Enter key is in only one horizontal row of keys.	Record error code MOKBD001; then go to "Step 1020-3."
Type 102 keyboard (W.T.). Identify by the size of the Enter key. The Enter key extends into two horizontal rows.	Record error code MOKBD002; then go to "Step 1020-3."
Kanji-type keyboard. (Identify by the Japanese characters.)	Record error code MOKBD003; then go to "Step 1020-3."
ASCII terminal keyboard	Go to the documentation for this type of ASCII terminal and continue problem determination.

Step 1020-3

Take the following actions:

1. Find the eight-digit error code in Chapter 3, "Error Code to FRU Index" on page 3-1.

Note: If the eight-digit error code is not listed in Chapter 3, "Error Code to FRU Index," look for it in the following:

- Any supplemental service manual for the device
- The diagnostic problem report screen for additional information
- The Service Hints service aid
- The CEREA.DME file (by using the Service Hints service aid).

2. Perform the action listed.

Step 1020-4

1. Check the SMS error log for any errors. To check the error log:

- Choose tools
- Choose error log
- If an error is logged, check the time stamp.
- If the error was logged during the current boot attempt, record it.
- Look up the error in the Error-Code-to FRU Index and do the listed action.
- If no recent error is logged in the error log, go to “MAP 1540: Minimum Configuration” on page 2-18.

MAP 1520: Power

Note: This is not a start of call MAP. Use this Power MAP only if you have been directed here from a MAP step in the *IBM RS/6000 Diagnostic Information for Multiple Bus Systems*.

This procedure is used to locate power problems in system units. If a problem is detected, this procedure helps you isolate the problem to a failing unit.

Observe the following safety notice during service procedures.

DANGER

An electrical outlet that is not correctly wired could place hazardous voltage on metal parts of the system or the devices that attach to the system. It is the responsibility of the customer to ensure that the outlet is correctly wired and grounded to prevent and electrical shock.

Before installing or removing signal cables, ensure that the power cables for the system unit and all attached devices are unplugged.

When adding or removing any additional devices to or from the system, ensure that the power cables for those devices are unplugged before the signal cables are connected. If possible, disconnect all power cables from the existing system before you add a device.

Use on hand, when possible, to connect or disconnect signal cables to prevent a possible shock from touching two surfaces with different electrical potentials.

During an electrical storm, do not connect cables for display stations, printers, telephones, or station protectors for communication lines.

CAUTION:

This product is equipped with a three-wire power cable and plug for the user's safety. Use this power cable with a properly grounded electrical outlet to avoid electrical shock.

DANGER

To prevent electrical shock hazard, disconnect the power cable from the electrical outlet before relocating the system.

Step 1520-1

You may be directed to this MAP for one of these reasons:

1. There is no indication of activity, even when the start/stop switch is pressed.
None of the LEDs light and the power supply fan does not turn.
Go to "Step 1520-2."
2. With the power good LED blinking slowly when the start/stop switch is pressed, the system begins to power on, but the power good LED does not stay on.
Go to "Step 1520-3" on page 2-14.

Step 1520-2

1. Turn the power off.
2. Check that the external power cable to the system unit has continuity.
3. Check that the power outlet has been wired correctly with the correct voltage.
4. Check that the external power cable is plugged into both the system unit and the power outlet.

Did you find a problem?

- NO** Go to "Step 1520-3" on page 2-14.
- YES** Correct the problem. Go to "Map 0410: Repair Checkout" in the *IBM RS/6000 Diagnostic Information for Multiple Bus Systems*.

Step 1520-3

Note: Either the power supply, the system board or the start/stop switch is defective. Check the power supply first.

1. Unplug the power cord from the system. Press and hold the start/stop switch for a few seconds (to discharge the power supply).
2. Connect the power cord to the system.
3. There is a small black and white cable with a 2-pin connector hanging from the main power supply. With a small screwdriver or similar tool, short the two pins together for a few seconds.

Does the system power up while you short the pins? (You will hear the fan and see the power good LED turn on. When you release the short, the system will power down).

NO Replace the power supply and go to "Step 1520-5" on page 2-15.

YES Go to "Step 1520-4."

Step 1520-4

The power supply is working properly.

Ensure that the start/stop switch is securely connected to the system board connector (J37).

Did you find the problem?

NO Go to "Step 1520-5" on page 2-15.

YES Go to "Map 0410: Repair Checkout" in the *IBM RS/6000 Diagnostic Information for Multiple Bus Systems*.

Step 1520-5

Unplug the start/stop switch connector from J37. Check the operation of the start/stop switch with an Ohm meter. (The switch is normally open and closes when pressed.)

Does the switch operate correctly?

- NO** Replace the start/stop switch (Be sure to connect it to the system board connector (J37). Go to "Step 1520-6."
- YES** Go to "Map 0410: Repair Checkout" in the *IBM RS/6000 Diagnostic Information for Multiple Bus Systems*.

Step 1520-6

Turn the power on.

Does the fan in the power supply turn on and the power good LED come on and stay on?

- NO** Reinstall the original operator panel electronics assembly and go to "Step 1520-7" on page 2-16.
- YES** Go to "Map 0410: Repair Checkout" in the *IBM RS/6000 Diagnostic Information for Multiple Bus Systems*.

Step 1520-7

1. Turn the power off.
2. Unplug the system unit power cable from the wall outlet.
3. Record the slot numbers of all the ISA and PCI adapters. Label and record the location of any cables attached to the adapters. Remove all the adapters.
4. Remove all the memory modules.
5. Remove the CPU card.
6. Unplug the power cables from all the SCSI devices.
7. Unplug all the fans, except the fan in the power supply.
8. Connect the system unit power cable to the wall outlet.
9. Turn the power on.

Does the fan in the power supply turn on and the power good LED come on and stay on?

- NO** Replace the system board. Go to "Map 0410: Repair Checkout" in the *IBM RS/6000 Diagnostic Information for Multiple Bus Systems*.
- YES** Go to "Step 1520-8" on page 2-17.

Step 1520-8

One of the parts that was removed or unplugged is causing the problem. Install or connect the parts in the following order.

1. CPU card.
2. Memory modules.
3. SCSI devices, lowest bay to highest bay.
4. PCI cards, lowest slot to highest slot.
5. ISA cards, lowest slot to highest slot.
6. Fans.

Turn the power on after each part is installed or connected. If the system does not power on or the power good LED does not stay on, the most recently installed or connected part is causing the failure.

1. Turn the power off.
2. Unplug the system unit power cable from the wall outlet.
3. Install or connect one of the parts in the list.
4. Connect the system unit power cable to the wall outlet.
5. Turn the power on.

Does the fan in the power supply turn on and the power good LED come on and stay on?

NO Replace the last part you installed.

Repeat these steps until all the parts have been installed.

If the symptom did not change and all the parts have been replaced, call your service support person for assistance.

If the symptom has changed, check for loose cards, cables, and obvious problems. If you do not find a problem, return to "Step 1520-1" on page 2-13 in this MAP and follow the instructions for the new symptom.

YES Go to "Map 0410: Repair Checkout" in the *IBM RS/6000 Diagnostic Information for Multiple Bus Systems*.

MAP 1540: Minimum Configuration

Notes:

1. This MAP assumes that a CD-ROM drive is installed and connected to the integrated SCSI adapter, and a Diagnostics CD-ROM disc is available.
2. If a power-on password or privileged-access password is installed, you will be prompted to enter the password before the diagnostic CD-ROM will load.
3. The term "POST indicators" refer to the ICONs (graphic display) or device mnemonics (ASCII terminal) that display while the POST is executing.

Purpose of this MAP

This MAP is used to locate defective FRUs not found by normal diagnostics. For this procedure, diagnostics are run on a minimally-configured system. If a failure is detected on the minimally-configured system, the remaining FRUs are exchanged one at a time until the failing FRU is identified. If a failure is not detected, FRUs are added back until the failure occurs. The failure is then isolated to the failing FRU.

The MAP steps on the following pages instruct you to reduce the system to one or more of the following configurations:

- System board, CPU card, 1 memory module.
If no failure is detected, the green power LED will be on and the system will beep twice (one short beep, followed by one long beep up to a minute or more later). Any other response means one of the remaining FRUs is failing.
- System board, CPU card, all memory modules and a terminal attached to the S1 port or a keyboard, display, and graphics adapter.
If no failure is detected, The power LED will be on and the system will beep twice (one short, followed by one long beep up to a minute or more later). The SMS screen will be displayed.
- System board, CPU card, all memory modules, CD-ROM drive, and a terminal attached to the S1 port or a keyboard, display, and graphics adapter.
If no failure is detected, The power LED will be on and the system will beep twice (one short, followed by one long beep up to minute or more later). The POST indicators will be displayed. After the CD-ROM loads a screen titled "Please define the System Console" will be displayed. Any other response means one of the remaining FRUs is failing.

Step 1540-1

1. Ensure that the diagnostics and the operating system are shut down.
2. Turn the power off.
3. Turn the power on.
4. Insert the diagnostic CD-ROM into the CD-ROM drive.
5. When the POST indicators are displayed and before the long beep, press the F5 key (Graphics) or number 5 key (ASCII terminal).
6. Wait until the "Please define the system console" screen is displayed or the system appears to stop.

Is the "Please define the System Console" screen displayed?

- NO** Go to "Step 1540-2" on page 2-20.
- YES** Go to "Step 1540-13" on page 2-30.

Step 1540-2

1. Turn the power off.
2. Record the slot numbers of the ISA and PCI adapters. Label and record the location of any cables attached to the adapters. Remove all the adapters.
3. Record the slot numbers of the memory modules, and then remove all but one of the memory modules.
4. Remove the service processor (if present).
5. Disconnect the SCSI cable from the SCSI connector on the system board.
6. Disconnect the diskette drive cable from the diskette drive connector on the system board.
7. Disconnect the serial and parallel port cables from the rear of the system unit.
8. Disconnect the keyboard and mouse cables from the rear of the system unit.
9. Turn the power on.
10. Wait until the system beeps twice (one short, followed by one long beep up to a minute or more later) or the system appears to stop.

Did the system beep twice?

NO Go to "Step 1540-3" on page 2-21.

YES Go to "Step 1540-4" on page 2-22.

Step 1540-3

One of the FRUs remaining in the system unit is defective.

If the disk activity indicator LED is ON, exchange FRU's in this order:

1. System board
2. Memory module
3. CPU card

If the disk activity indicator LED is OFF, exchange FRU's in this order:

1. CPU card
2. System board
3. Memory module

The system is working correctly if it beeps twice (one short, and a minute or more later, one long).

1. Turn the power off.
2. Exchange one of the FRUs in the list, based on the order you determined above.
3. Turn the power on.

Did the system beep twice?

NO Reinstall the original FRU.

Repeat the FRU replacement steps until the defective FRU is identified or all the FRUs have been exchanged.

If the symptom did not change and all the FRUs have been exchanged, call your service support person for assistance.

If the symptom has changed, check for loose cards, cables, and obvious problems. If you do not find a problem, return to "Step 1540-1" on page 2-19 in this MAP and follow the instructions for the new symptom.

YES Go to "Map 0410: Repair Checkout" in the *IBM RS/6000 Diagnostic Information for Multiple Bus Systems*.

Step 1540-4

No failure was detected with this configuration.

1. Turn the power off.
2. Install a memory module.
3. Turn the power on.
4. Wait until the system beeps twice or the system appears to stop.
5. The system beeps once (one short).
6. The system does not beep.

Did the system beep twice?

NO Go to "Step 1540-5."

YES Repeat this step until all the memory modules are installed and tested.

After all the memory modules are installed and tested, turn the power to off.

Go to "Step 1540-7" on page 2-24.

Step 1540-5

The failure may be caused by the last memory module installed. To isolate the failing FRU, do the following:

1. Turn the power off.
2. Exchange the last memory module installed.
3. Turn the power on.

Did the system beep twice?

NO Go to "Step 1540-6" on page 2-23.

YES Go to "Map 0410: Repair Checkout" in the *IBM RS/6000 Diagnostic Information for Multiple Bus Systems*.

Step 1540-6

One of the FRUs remaining in the system unit is defective.

To test each FRU, exchange the FRUs that have not already been exchanged in the following order:

- System board
- Power supply.

The system is working correctly if it beeps twice (one short, and a minute or more later, one long).

1. Turn the power off.
2. Exchange one of the FRUs in the list.
3. Turn the power on.

Did the system beep twice?

NO Reinstall the original FRU.

Repeat this step until the defective FRU is identified or all the FRUs have been exchanged.

If the symptom did not change and all the FRUs have been exchanged, call your service support person for assistance.

If the symptom has changed, check for loose cards, cables, and obvious problems. If you do not find a problem, return to "Step 1540-1" on page 2-19 in this MAP, and follow the instructions for the new symptom.

YES Go to "Map 0410: Repair Checkout" in the *IBM RS/6000 Diagnostic Information for Multiple Bus Systems*.

Step 1540-7

If you removed a service processor in “Step 1540-2” on page 2-20, continue with this step.

If you did not remove a service processor in “Step 1540-2” on page 2-20, go to “Step 1540-8” on page 2-25.

1. Turn the power off.
2. Install the service processor.
3. Turn the power on.
4. Wait until the system beeps twice or the system appears to stop.

Did the system beep twice?

- NO** Replace the service processor.
- YES** Go to “Step 1540-8” on page 2-25.

Step 1540-8

1. Turn the power off.
2. Reconnect the system console.

Notes:

- a. If a terminal attached to S1 or S2 is the system console, plug the terminal cable into the S1 or S2 connector on the rear of the system unit.
 - b. If a display attached to a display adapter is the system console, install the display adapter and connect the display to it. Plug the keyboard into the keyboard connector on the rear of the system unit.
3. Turn the power on.
 4. Wait until the SMS screen is displayed or the system appears to stop.

Is the SMS screen displayed?

NO One of the FRUs remaining in the system unit is defective.

In the following order, exchange the FRUs that have not been exchanged:

1. Go to the Problem Determination Procedures (test procedures) for the device attached to the SIO serial port or the display attached to the graphics adapter, and test those devices. If a problem is found, follow the procedures for correcting the problem on that device.
2. Graphics adapter (if installed).
3. Cable (async or graphics).
4. System board.

Repeat this step until the defective FRU is identified or all the FRUs have been exchanged.

If the symptom did not change and all the FRUs have been exchanged, call your service support person for assistance.

If the symptom changed, check for loose cards and obvious problems. If you do not find a problem, return to "Step 1540-1" on page 2-19 and follow the instructions for the new symptom.

YES Go to "Step 1540-9" on page 2-26.

Step 1540-9

1. Turn the power off.
2. Plug the SCSI cable into the SCSI connector on the system board.
3. Disconnect the signal and power connectors from all the SCSI devices except the CD-ROM drive.
4. Turn the power on.
5. Insert the diagnostic CD-ROM into the CD-ROM drive.
6. After the POST indicators are displayed and before the long beep press the F5 key on a direct attached keyboard or the number 5 key on a ASCII terminal keyboard.
7. Wait until the "Please define the System Console" screen is displayed or the system appears to stop.

Is the "Please define the System Console" screen displayed?

- NO** One of the FRUs remaining in the system unit is defective.
- In the following order, exchange the FRUs that have not been exchanged:
1. System board
 2. CPU card
 3. Last SCSI device connected (CD-ROM drive, tape drive, etc)
 4. SCSI cable
- Repeat this step until the defective FRU is identified or all the FRUs have been exchanged.
- If the symptom did not change and all the FRUs have been exchanged call your service support person for assistance.
- If the symptom has changed check for loose cards, cables, and obvious problems. If you do not find a problem return to "Step 1540-1" on page 2-19 in this MAP and follow the instructions for the new symptom.
- YES** Repeat this step until all the SCSI devices that were attached to the integrated SCSI adapter are connected and tested.
- Go to "Step 1540-10" on page 2-27.

Step 1540-10

The system is working correctly with this configuration. One of the FRUs (adapters) that you removed is probably defective.

1. Turn the power off.
2. Plug the diskette drive cable into the diskette drive connector on the system board.
3. Turn the power on.
4. Insert the diagnostic CD-ROM disc into the CD-ROM drive.
5. After the POST indicators are displayed and before the long beep press the F5 key on a direct attached keyboard or the number 5 key on a ASCII terminal keyboard.
6. Wait until the "Please define the System Console" screen is displayed or the system appears to stop.

Is the "Please define the System Console" screen displayed?

NO One of the FRUs remaining in the system is defective.

In the following order, exchange the FRUs that have not been exchanged.

1. Diskette drive
2. Diskette drive cable
3. System board
4. Power supply

Repeat this step until the defective FRU is identified or all the FRUs have been exchanged.

If the symptom did not change and all the FRUs have been exchanged, call your service support person for assistance.

If the symptom has changed check for loose cards, cables, and obvious problems. If you do not find a problem return to "Step 1540-1" on page 2-19 in this MAP and follow the instructions for the new symptom.

YES Go to "Step 1540-11" on page 2-28.

Step 1540-11

The system is working correctly with this configuration. One of the FRUs (adapters) that you removed is probably defective,

1. Turn the power off.
2. Install a FRU (adapter) and connect any cables and devices that were attached to it.
3. Turn the power on.
4. Insert the diagnostic CD-ROM disc into the CD-ROM drive.
5. After the POST indicators are displayed and before the long beep press the F5 key on a direct attached keyboard or the number 5 key on a ASCII terminal keyboard.
6. Wait until the "Please define the System Console" screen is displayed or the system appears to stop.

Is the "Please define the System Console" screen displayed?

NO Go to "Step 1540-12" on page 2-29.

YES Repeat this step until all of the FRUs (adapters) are installed. If you have exchanged all of the FRUs (adapters) and the symptom did not change, go to MAP 0020 in the *IBM RS/6000 Diagnostic Information for Multiple Bus Systems*.

Step 1540-12

1. Turn the power off.
2. Starting with the last installed adapter, disconnect one attached device and cable.
3. Turn the power on.
4. Insert the diagnostic CD-ROM disc into the CD-ROM drive.
5. After the POST indicators are displayed and before the long beep press the F5 key on a direct attached keyboard or the number 5 key on a ASCII terminal keyboard.
6. Wait until the "Please define the System Console" screen is displayed or the system appears to stop.

Is the "Please define the System Console" screen displayed?

NO Repeat this step until the defective device or cable is identified or all the devices and cables have been disconnected.

If all the devices and cables have been removed, then one of the FRUs remaining in the system unit is defective.

To test each FRU, exchange the FRUs in the following order:

1. Adapter (last one installed)
2. System board
3. Power supply

If the symptom did not change and all the FRUs have been exchanged, call your service support person for assistance.

If the symptom has changed check for loose cards, cables, and obvious problems. If you do not find a problem return to "Step 1540-1" on page 2-19 in this MAP and follow the instructions for the new symptom.

YES The last device or cable that you disconnected is defective.

Exchange the defective device or cable.

Go to "Map 0410: Repair Checkout" in the *IBM RS/6000 Diagnostic Information for Multiple Bus Systems*.

Step 1540-13

1. Turn the power off.
2. Record the slot numbers of the ISA and PCI adapters. Label and record the location of any cables attached to the adapters. Remove all the adapters except the display adapter (if installed and the attached display will be the system console).
3. Disconnect any cables that are plugged into connectors S1, S2, P, K, and M on the rear of the system unit.

Note: If a terminal attached to S1 or S2 will be the system console, do not disconnect it. If a display attached to a display adapter will be the system console, do not disconnect the keyboard.

4. Turn the power on.
5. Insert the diagnostic CD-ROM disc into the CD-ROM drive.
6. After the POST indicators are displayed and before the long beep press the F5 key on a direct attached keyboard or the number 5 key on a ASCII terminal keyboard.
7. Wait until the "Please define the System Console" screen is displayed or the system appears to stop.

Is the "Please define the System Console" screen displayed?

- NO** The symptom has changed. Check for loose cards, cables, and obvious problems. If you do not find a problem return to "Step 1540-1" on page 2-19 in this MAP and follow the instructions for the new symptom.
- YES** Go to "Step 1540-14" on page 2-31.

Step 1540-14

1. Follow the instructions on the screen to select the system console.
2. When the DIAGNOSTIC OPERATING INSTRUCTIONS screen is displayed, press Enter.
3. If the terminal type has not been defined, you must use the Initial Terminal option on the FUNCTION SELECTION menu to initialize the AIX operating system environment before you can continue with the diagnostics. This is a separate and different operation than selecting the console display.
4. Select Advanced Diagnostic Routines.
5. When the DIAGNOSTIC MODE SELECTION menu displays, select System Verification.
6. Start with the first item on the list and test all the adapters and devices.

Did you get an SRN?

- NO** Go to "Step 1540-16" on page 2-32.
- YES** Go to "Step 1540-15."

Step 1540-15

Look at the FRU part numbers associated with the SRN.

Have you exchanged all the FRUs that correspond to the failing function codes?

- NO** Exchange the FRU with the highest failure percentage that has not been changed.
- Repeat this step until all the FRUs associated with the SRN have been exchanged or diagnostics run with no trouble found. Run diagnostics after each FRU is exchanged.
- Go to "Map 0410: Repair Checkout" in the *IBM RS/6000 Diagnostic Information for Multiple Bus Systems*.
- YES** If the symptom did not change and all the FRUs have been exchanged, call your service support person for assistance.

Step 1540-16

One of the adapters or devices you removed is causing the problem.

Install the adapters and devices one at a time to determine the failing adapter or device. If the adapter you are installing is an ISA adapter, go to the Service Aids to configure it. If the adapter or device you are installing (ISA or PCI) will not configure or causes the system to stop, replace the adapter or device. Test each adapter or device after installing it.

Repeat this step until all the adapters and devices you removed are installed.

Go to "MAP 0410: Repair Checkout" in the *IBM RS/6000 Diagnostic Information for Multiple Bus Systems*.

If the symptom did not change and all the FRUs have been exchanged, call your service support person for assistance.

Chapter 3. Error Code to FRU Index

The Error Code to FRU Index lists error symptoms and possible causes. The most likely cause is listed first. Use this index to help you decide which FRUs to replace when servicing the system. If you replace FRUs and the problem is still not corrected, go to MAP 0030 in the *IBM RS/6000 Diagnostic Information for Multiple Bus Systems*.

Some three digit Fxx codes may appear to the left of the top row on the Liquid Crystal Display(LCD) which is located on the front panel of the system. The intended use of the three digit Fxx codes is to assure the observer that the Firmware is operational after power on, and before information appears on the console display.

If any action is to be taken, it is listed in column two of the following table. If the three digit Fxx code is not in the following table, and an action is still required, go to "MAP 1540: Minimum Configuration" on page 2-18.

See Appendix A, "Firmware Checkpoint Three-Digit Codes" on page A-1 for the complete list of three digit Fxx codes.

<i>Table 3-1. POST Error Codes</i>			
Error Code	F Code / Description		Action / Possible Failing FRU
00010000	An error occurred during the CPU test.		CPU card
0001000A	Machine check occurred.		Go to MAP 1540.
0001500x	An error occurred while erasing the system firmware. Firmware update was not completed.		CPU card
00016000	F46	Interrupt (IRQ13) stuck high	1. System board; swap old VPD module to new system board 2. Service processor, if present
	F47	No system board VPD data. Module missing or bad CRC.	System board; swap old VPD module to new system board
	F49	Environmental condition 40111022/40111082, 5V high/low. EPOW register could not be cleared.	1. Power supply 2. CPU card 3. System board; swap old VPD module to new system board

Table 3-2. POST Error Codes

Error Code	F Code / Description		Action / Possible Failing FRU
00016000 (continued)	F4A	Environmental condition 40111052/401110B2/40111062/401110C2, +-12V high/low. EPOW register could not be cleared.	<ol style="list-style-type: none"> 1. Power supply 2. CPU card 3. System board; swap old VPD module to new system board
	F4B	Environmental condition 40200021. CPU card over temperature. EPOW register could not be cleared.	<ol style="list-style-type: none"> 1. Check for cool air flow obstructions to the system 2. System board; swap old VPD module to new system board
	F4F	Environmental condition 40200031/40200041, system board/memory over temperature. EPOW register could not be cleared.	System board; swap old VPD module to new system board
	F51	Environmental condition 40200023. CPU card critical temperature. EPOW register could not be cleared.	<ol style="list-style-type: none"> 1. Check for cool air flow obstructions to the system 2. Replace CPU card if the problem persists 3. System board; swap old VPD module to new system board
	F51	Environmental condition 40200033/40200043, system board/memory critical temperature. EPOW register could not be cleared.	<ol style="list-style-type: none"> 1. Check for cool air flow obstructions to the system 2. System board; swap old VPD module to new system board

<i>Table 3-3 (Page 1 of 13). POST Error Codes</i>			
Error Code	F Code / Description		Action / Possible Failing FRU
00016000 (continued)	F52	Environmental condition 40210011/40210014, slow/locked fan. EPOW register could not be cleared.	<ol style="list-style-type: none"> 1. Room operating temperature 2. System fans 3. System board; swap old VPD module to new system board
	F53	Environmental condition 40210011/40210014, slow/locked fan. EPOW register successfully cleared.	<ol style="list-style-type: none"> 1. Fan(s) 2. System board; swap old VPD module to new system board 3. Service processor if present
	F55	Unsupported EPOW	<ol style="list-style-type: none"> 1. System board; swap old VPD module to new system board 2. Service processor if present
	F56	Environmental condition 40111032/40111092/40111042/401110A2, 3.3V/2.5V high/low. EPOW register could not be cleared.	<ol style="list-style-type: none"> 1. CPU card 2. Power supply 3. System board; swap old VPD module to new system board 4. Service processor if present
00016010	System VPD access failure		<ol style="list-style-type: none"> 1. System board; swap old VPD module to new system board 2. If problem persists, swap new VPD module onto new system board; also see step 3) 3. If customer has protected licensed software installed then advise customer to contact all protected software suppliers for a licence update.
00017001	CMOS error was detected due to battery drainage.		Replace your battery
00017002	Error was detected in CMOS, CMOS data is gone! CMOS not yet initialized if battery just replaced.		Replace battery if you haven't done so.
00017003	Power interruption occurred during last Boot Sequence update.		Update the Boot Sequence again.
00017006	Tamper Evident is detected or new battery was just being installed.		Security violation possible.

Table 3-3 (Page 2 of 13). POST Error Codes

Error Code	F Code / Description	Action / Possible Failing FRU
00017007	Maximum number of tries was reached!! Time and Date are logged! Computer is stopping.	Turn machine off and back on, re-enter password
00017008	Maximum number of tries was reached!! Computer is stopping.	Turn machine off and back on, re-enter password
00017013	No power on password entered. Unattended mode can not be set.	<ol style="list-style-type: none"> 1. Quit unattended mode 2. Set power-on password 3. Retry operation
00017015	Tamper Evident is detected.	Security violation or Bad CMOS battery.
00018000	Bad flash image discovered during system start-up	CPU card
00020000	An error occurred during the memory test.	Use System Management Services to test the memory.
000210y0	An error occurred during the memory test. y represents memory module slot number	Memory module slot number y (y = 1 to 8) is bad or unsupported.
00031100	The keyboard is in the wrong port.	Check keyboard cable and connector.
00031300	Failed to register keyboard interrupt	<ol style="list-style-type: none"> 1. Keyboard 2. System board; swap old VPD module onto new system board.
00070000	Service processor POST failure	<ol style="list-style-type: none"> 1. Service processor 2. System board; swap old VPD module onto new system board
00070001	CPU card or power supply failure	<ol style="list-style-type: none"> 1. CPU card 2. Power supply
00070006	Slow or stuck fan	<ol style="list-style-type: none"> 1. Fans 2. Service processor, if present 3. System board; swap old VPD module onto new system board
00070007	System over temperature	<ol style="list-style-type: none"> 1. Check for cool air flow obstructions to the system 2. Replace system board if the problem persists; also swap old VPD module onto new system board 3. CPU card

<i>Table 3-3 (Page 3 of 13). POST Error Codes</i>			
Error Code	F Code / Description		Action / Possible Failing FRU
00070008	F4F	Environmental condition 40200031/40200041, system board/memory over temperature. EPOW register successfully cleared.	<ol style="list-style-type: none"> 1. Check for cool air flow obstructions to the system 2. Replace system board if the problem persists; also swap old VPD module onto new system board 3. Memory
	F51	Environmental condition 40200033/40200043, system board/memory critical temperature. EPOW register successfully cleared.	<ol style="list-style-type: none"> 1. Check for cool air flow obstructions to the system 2. Replace system board if the problem persists; also swap old VPD module onto new system board 3. Memory
00070009	F4B	Environmental condition 40200021, CPU card over temperature. EPOW register successfully cleared.	<ol style="list-style-type: none"> 1. Check for cool air flow obstructions to the system 2. Replace CPU card if the problem persists 3. System board; swap old VPD module onto new system board
	F51	Environmental condition 40200023, CPU card critical temperature. EPOW register successfully cleared.	<ol style="list-style-type: none"> 1. Check for cool air flow obstructions to the system 2. Replace CPU card if the problem persists 3. System board; swap old VPD module onto new system board
00070010	F48	Environmental condition 40100005. AC loss eminent.	<ol style="list-style-type: none"> 1. Power supply 2. System board; swap old VPD module onto new system board 3. Service processor, if present
	F4A	Environmental condition 40111052/401110B2/40111062/401110C2, +-12V high/low. EPOW register successfully cleared.	<ol style="list-style-type: none"> 1. Power supply 2. System board; swap old VPD module onto new system board

Table 3-3 (Page 4 of 13). POST Error Codes

Error Code	F Code / Description	Action / Possible Failing FRU
00070011	Environmental condition 40111022/40111082, 5V high/low. EPOW register successfully cleared.	<ol style="list-style-type: none"> 1. Power supply 2. CPU card 3. System board; swap old VPD module onto new system board
00070012	Service processor reports self-test failure	<ol style="list-style-type: none"> 1. Service processor, if present 2. System board; swap old VPD module onto new system board
00070013	Bad NVRAM CRC error	<ol style="list-style-type: none"> 1. Battery 2. System board; swap old VPD module onto new system board
00070014	Bad service processor firmware	Use service processor firmware diskette to re-program firmware
00070015	Bad service processor VPD	<ol style="list-style-type: none"> 1. Service processor, if present 2. System board; swap old VPD module onto new system board
00070016	Service processor firmware failure	<ol style="list-style-type: none"> 1. Retry service processor firmware update 2. Service processor, if present
00070017	Bad or low battery	<ol style="list-style-type: none"> 1. Battery 2. Service processor, if present 3. System board; swap old VPD module onto new system board
00070018	EPOW test failure	<ol style="list-style-type: none"> 1. Service processor, if present 2. System board; swap old VPD module onto new system board
00070019	Interrupt (IRQ13) test failure	<ol style="list-style-type: none"> 1. System board; swap old VPD module onto new system board 2. Service processor, if present

Table 3-3 (Page 5 of 13). POST Error Codes

Error Code	F Code / Description	Action / Possible Failing FRU
0037cyi	<p>SCSI controller interface error.</p> <p>c = SCSI Controller ID assigned by search order PCI slot 1, 2, integrated controller, PCI slot 3 through last.</p> <p>Example: #1 1st SCSI controller card in slot 2 = ID 0 Integrated SCSI controller = ID 1</p> <p>Example: #2 Integrated SCSI controller = ID 0 1st SCSI controller card in slot 3 = ID 1</p> <p>yy = See Table 3-4 on page 3-16</p> <p>i = SCSI ID(0 to 9 or A through F). F normally indicates the controller.</p>	<ol style="list-style-type: none"> 1. Ensure that the controller and each device on the SCSI bus is assigned a unique SCSI ID. 2. Ensure SCSI bus terminator is installed properly. 3. Ensure SCSI cable/connector are securely connected and not damaged. 4. SCSI controller or Integrated SCSI Controller on system board as identified by "c" in the error code.
01291000	An error occurred during the L2 Cache tests.	CPU Card

Table 3-3 (Page 6 of 13). POST Error Codes

Error Code	F Code / Description	Action / Possible Failing FRU
0208cyyi	<p>SCSI device/adapter error.</p> <p>c = SCSI Controller ID assigned by search order PCI slot 1, 2, integrated controller, PCI slot 3 through last.</p> <p>Example: #1 1st SCSI controller card in slot 2 = ID 0 Integrated SCSI controller = ID 1</p> <p>Example: #2 Integrated SCSI controller = ID 0 1st SCSI controller card in slot 3 = ID 1</p> <p>yy = See Table 3-4 on page 3-16</p> <p>i = SCSI ID(0 to 9 or A through F). F normally indicates the controller.</p>	<ol style="list-style-type: none"> 1. Ensure that the controller and each device on the SCSI bus is assigned a unique SCSI ID. 2. Ensure SCSI bus terminator is installed properly. 3. Ensure SCSI cable/connector are securely connected and not damaged. 4. SCSI device as identified by "i". <p>If the device is not the CD-ROM drive, remove the device. Try loading standalone diagnostics. If the diagnostics load, replace the device identified by "i".</p> <p>If the device is the CD-ROM drive or the diagnostics will not load with the device identified by "i" removed, remove all devices except the CD-ROM drive. Try loading standalone diagnostics. If the diagnostics load, add the devices back one at a time until the failing device is identified. Check each device by loading standalone diagnostics.</p> <p>If the diagnostics do not load, replace the CD-ROM drive. If the diagnostics still do not load, then replace the SCSI controller identified by "c".</p>

Table 3-3 (Page 7 of 13). POST Error Codes

Error Code	F Code / Description	Action / Possible Failing FRU
0210cyi	<p>SCSI DASD error.</p> <p>c = SCSI Controller ID assigned by search order PCI slot 1, 2, integrated controller, PCI slot 3 through last.</p> <p>Example: #1 1st SCSI controller card in slot 2 = ID 0 Integrated SCSI controller = ID 1</p> <p>Example: #2 Integrated SCSI controller = ID 0 1st SCSI controller card in slot 3 = ID 1</p> <p>yy = See Table 3-4 on page 3-16</p> <p>i = SCSI ID(0 to 9 or A through F). F normally indicates the controller.</p>	<ol style="list-style-type: none"> 1. Ensure that the controller and each device on the SCSI bus is assigned a unique SCSI ID. 2. Ensure SCSI bus terminator is installed properly. 3. Ensure SCSI cable/connector are securely connected and not damaged. 4. SCSI Disk Device connected to SCSI adapter "c" and assigned SCSI ID="i".
0211cyi	<p>SCSI tape error.</p> <p>c = SCSI Controller ID assigned by search order PCI slot 1, 2, integrated controller, PCI slot 3 through last.</p> <p>Example: #1 1st SCSI controller card in slot 2 = ID 0 Integrated SCSI controller = ID 1</p> <p>Example: #2 Integrated SCSI controller = ID 0 1st SCSI controller card in slot 3 = ID 1</p> <p>yy = See Table 3-4 on page 3-16</p> <p>i = SCSI ID(0 to 9 or A through F). F normally indicates the controller.</p>	<ol style="list-style-type: none"> 1. Ensure that the controller and each device on the SCSI bus is assigned a unique SCSI ID. 2. Ensure SCSI bus terminator is installed properly. 3. Ensure SCSI cable/connector are securely connected and not damaged. 4. SCSI Tape Device connected to SCSI adapter "c" and assigned SCSI ID="i".

Table 3-3 (Page 8 of 13). POST Error Codes

Error Code	F Code / Description	Action / Possible Failing FRU
0215cyi	<p>SCSI CDROM error.</p> <p>c = SCSI Controller ID assigned by search order PCI slot 1, 2, integrated controller, PCI slot 3 through last.</p> <p>Example: #1 1st SCSI controller card in slot 2 = ID 0 Integrated SCSI controller = ID 1</p> <p>Example: #2 Integrated SCSI controller = ID 0 1st SCSI controller card in slot 3 = ID 1</p> <p>yy = See Table 3-4 on page 3-16</p> <p>i = SCSI ID (0 to 9 or A through F). F normally indicates the controller.</p>	<ol style="list-style-type: none"> 1. Ensure that the controller and each device on the SCSI bus is assigned a unique SCSI ID. 2. Ensure SCSI bus terminator is installed properly. 3. Ensure SCSI cable/connector are securely connected and not damaged. 4. SCSI CDROM Device connected to SCSI adapter "c" and assigned SCSI ID="i".
0243025y	The Graphics Controller, DAC, Frame Buffer, Graphics Function test failed.	Graphic PCI card in slot y
40100005	A loss of system power detected.	Possible main power loss. If not, replace power supply.
40111002	An unknown power problem detected.	<ol style="list-style-type: none"> 1. Power supply 2. System board; swap old VPD module to new system board 3. Service processor, if present
40111022	A high 5.0 voltage reading detected.	<ol style="list-style-type: none"> 1. Power supply 2. CPU card
40111032	A high 3.3 voltage reading detected.	<ol style="list-style-type: none"> 1. CPU card 2. Power supply
40111042	A high 2.5 voltage reading detected.	<ol style="list-style-type: none"> 1. CPU card 2. Power supply
40111052	A high +12 voltage reading detected.	<ol style="list-style-type: none"> 1. Power supply 2. System board; swap old VPD module to new system board
40111062	A high -12 voltage reading detected.	<ol style="list-style-type: none"> 1. Power supply 2. System board; swap old VPD module to new system board
40111082	A low 5.0 voltage reading detected.	<ol style="list-style-type: none"> 1. Power supply 2. CPU card

<i>Table 3-3 (Page 9 of 13). POST Error Codes</i>		
Error Code	F Code / Description	Action / Possible Failing FRU
40111092	A low 3.3 voltage reading detected.	1. CPU card 2. Power supply
401110A2	A low 2.5 voltage reading detected.	1. CPU card 2. Power supply
401110B2	A low +12 voltage reading detected.	1. Power supply 2. System board; swap old VPD module to new system board
401110C2	A low -12 voltage reading detected.	1. Power supply 2. System board; swap old VPD module to new system board
40200001	An unknown cooling problem detected.	Cooling problem; check system fans.
40200021	A CPU temperature warning detected.	Over temperature on CPU card.
40200023	A critical CPU temperature condition detected.	Critical temperature on CPU card.
40200031	An I/O planar temperature warning detected.	Over temperature on system board.
40200033	A critical I/O planar temperature condition detected.	Critical temperature on system board.
40200041	A memory temperature warning detected.	Over temperature on system board.
40200043	A critical memory temperature condition detected.	Critical temperature on system board.
40210011	A slow fan detected.	Check: 1. Room operating temperature 2. System fans
40210014	A stopped fan detected.	Failing fan.

Table 3-3 (Page 10 of 13). POST Error Codes

Error Code	F Code / Description	Action / Possible Failing FRU
40A00000	System firmware IPL failure.	<ol style="list-style-type: none"> 1. Surveillance mode control is from the Service Processor (SP) Menus. 2. Verify that the system firmware supports SP surveillance. 3. CPU card 4. System board 5. Service processor 6. If the problem still exists, go to MAP 1540. 7. If the problem persists, call the support center for assistance.
40B00000	The operating system surveillance interval exceeded.	<ol style="list-style-type: none"> 1. Surveillance mode control is from the Service Processor(SP) Menus. 2. Verify that the Operating System (OS) Heartbeat Utility is installed and has been activated. 3. Check for errors or unusual conditions that might prevent the OS from reporting Heartbeat messages; such as system dump, machine check or checkstop error. Review the error log. 4. System board; swap old VPD module to new system board 5. Service processor 6. If the problem persists, call the support center for assistance.
40D00003	An unknown slow shutdown commanded.	Critical cooling problem.
40D00004	An unknown fast shutdown commanded.	Locked fan failure detected.
80001200	The firmware recovery information could not be written to the diskette.	<ol style="list-style-type: none"> 1. Check diskette media write protect tab. 2. Diskette drive

<i>Table 3-3 (Page 11 of 13). POST Error Codes</i>		
Error Code	F Code / Description	Action / Possible Failing FRU
80001300	The firmware update file is the same level as the system firmware. Firmware update cancelled.	<ol style="list-style-type: none"> 1. Obtain new level of firmware 2. Retry operation
80001400	The firmware update file does not support this system. Firmware update cancelled.	<ol style="list-style-type: none"> 1. Obtain the correct firmware file 2. Retry operation
80001500	The firmware update file on the current drive is corrupted. Firmware update cancelled.	<ol style="list-style-type: none"> 1. Obtain new firmware file 2. Retry operation
80001600	The firmware update file could not be located on the current drive. Firmware update cancelled.	Specify the correct drive and path name for firmware file.
80001700	The firmware update file on the current drive is corrupted. Firmware update cancelled.	<ol style="list-style-type: none"> 1. Obtain new firmware file 2. Retry operation
80001800	A valid firmware update file could not be located on the current drive. Firmware update cancelled.	<ol style="list-style-type: none"> 1. Specify the correct drive and path name for firmware file. 2. Obtain new firmware file 3. Retry operation
80001900	The firmware update file does not support this system. Firmware update cancelled.	<ol style="list-style-type: none"> 1. Obtain new firmware file 2. Retry operation
80002000	Two flash images found. User cancelled out of file select	Retry operation
80002100	The firmware update file could not be loaded from the current drive. Firmware update cancelled.	Specify the correct drive and path name for firmware file.
80002200	The firmware update module is write protected. Firmware update cancelled.	<ol style="list-style-type: none"> 1. Turn the system off and then back on. 2. Retry operation 3. CPU card 4. If problem persists, call support center for assistance.
80002300	This version of the update utility does not support this system. Firmware update cancelled.	<ol style="list-style-type: none"> 1. Turn the system off and then back on. 2. Retry operation 3. CPU card 4. If problem persists, call support center for assistance.

Table 3-3 (Page 12 of 13). POST Error Codes

Error Code	F Code / Description	Action / Possible Failing FRU
80002400	The firmware module is not supported. Firmware update cancelled.	Flash module on CPU card is malfunctioning.
80002500	The firmware module is not supported. Firmware update cancelled.	Flash module on CPU card is malfunctioning.
80002600	The firmware module is write protected.	<ol style="list-style-type: none"> 1. Turn the system off and then back on. 2. Retry operation 3. CPU card 4. If problem persists, call support center for assistance.
80002700	Backup recovery diskette is not inside the drive.	Insert backup diskette
80002800	Update system firmware diskette is not inside the drive.	Insert diskette
80072000	The service processor is not installed. Service processor update cancelled.	<ol style="list-style-type: none"> 1. Install the service processor 2. Retry operation
91001100	Remote IPL error. Insufficient memory.	<ol style="list-style-type: none"> 1. Run memory test, replace defective memory module. 2. This system has insufficient memory for this operation.
91001200	Remote IPL error. Incorrect IP format for client IP address.	Change/Update IP format
91001300	Remote IPL error. Incorrect IP format for server IP address.	Change/Update IP format
91001400	Remote IPL error. Incorrect IP format for gateway IP address.	Change/Update IP format
91001500	Remote IPL error. Incorrect IP format for netmask.	Change/Update IP format
91001600	Remote IPL error. Error writing to NVRAM.	System board; swap old VPD module onto new system board
91001700	Remote IPL error. Ethernet adapter not found.	Ensure network card is properly installed.
91001900	Remote IPL error. Token-Ring adapter not found.	Ensure network card is properly installed.
91002000	Remote IPL error. No network adapters recognized.	Ensure network card is properly installed.
91002200	Remote IPL error. Ping failed.	Possible IP address or network problem.
M0CON000	The system hung during POST.	Go to MAP 1540.

<i>Table 3-3 (Page 13 of 13). POST Error Codes</i>		
Error Code	F Code / Description	Action / Possible Failing FRU
M0CPU000	The CPU POST failed.	1. CPU Card 2. System Board
M0CPU001	Checkstop occurred.	1. CPU card 2. System board
M0FD0000	The system hung during diskette POST.	1. System board 2. Diskette drive.
M0GA0000	Graphics adapter POST failed.	Graphics adapter
M0HD0000	The system hung during boot POST.	Go to MAP 1540.
M0KBD000	The system hung during keyboard POST.	1. System board 2. Keyboard
M00KBD01	The system did not respond to a keyboard entry.	Type 101 keyboard
M0KBD002	The system did not respond to a keyboard entry.	Type 102 keyboard
M0KBD003	The system did not respond to a keyboard entry.	Kanji-type keyboard
M0MC0001	A machine check occurred.	Go to MAP 1540.
M0MEM000	No good memory could be found.	1. Memory 2. System board Note: If only one memory module is installed, replace it. If there are multiple memory modules installed, go to MAP 1540.
M0MEM001	No good memory could be found.	1. Memory 2. System board.
M0MEM002	The system hung during memory POST.	Go to MAP 1540.
M0PS0000	Power failure.	Go to MAP 1520.
M0SCSI00	Unable to load diagnostics.	Go to MAP 1540.
M0SCSI01	Unable to load diagnostics.	Go to Map 1540.
M0SPK000	A continuous beep is heard from the system.	System board
M0SPK001	The system does not beep.	1. System board 2. Speaker

Table 3-4 (Page 1 of 2). POST Error Status Codes

Error	Status
08	Invalid device number
11	No SCSI card
13	Command failed
28	Reservation conflict
29	Device not available
43	Not enough memory
47	Waiting for completion
49	Sense needed
51	Reset needed
55	Not ready or no media
56	Invalid (unsupported) command
57	Write protected
59	Media error
60	Hardware error
61	Unit attention
62	Blank check
63	Command abort
64	Busy
65	Media
66	Script error
67	Invalid address
68	Media changed
69	Device reset
70	Format in progress
71	Format corrupt
72	Start required
73	Device ID conflict
74	Manual intervention
75	Media not found
76	In progress
77	Media eject failed
78	Write protect failed
79	Controller memory to memory transfer test failed
80 - 81	SCSI Controller interface error
82	SCSI bus access error

Table 3-4 (Page 2 of 2). POST Error Status Codes

Error	Status
83	SCSI fuse bad or PTC
84	SCSI Device command failed
85 - 86	SCSI Controller interface error
87	Short record error
88	SCSI bus parity error
89	SCSI device no reset
90	Time out error
91	SCSI no audio
92	SCSI incompatible media
93	Tape requested/actual block size mismatch (normally)
94	Filemark or setmark read on tape device
95	Wide data transfer data miscompare error
96	Wide data transfer error other than data miscompare
97	Command not supported by device (eg. wide data transfer)
99	SCSI Controller interface error

Chapter 4. Loading the System Diagnostics

The system unit can be booted either from the default boot list or from the custom boot list. (See Chapter 5, "System Management Services" on page 5-1 for instructions on defining the custom boot list.)

To load **Standalone** diagnostics from the default boot list, perform the following procedure:

1. Verify with the system administrator and users that all programs may be stopped, then do so.
2. Turn off the system.
3. Wait 30 seconds, and turn on the system.
4. Immediately insert the diagnostic CD-ROM into the CD-ROM drive.
5. When or after the diskette indicator appears during startup, press the F5 key on a directly-attached keyboard (or the number 5 key on an ASCII terminal).
6. Enter any requested passwords.

Online diagnostics can be loaded by booting from the custom boot list by pressing the F6 key (on a directly-attached keyboard) or the number 6 key on an ASCII terminal.

The procedure for booting from the devices listed in the custom boot list (Online diagnostics) is the following:

1. Verify with the system administrator and users that all programs may be stopped, then do so.
2. Turn off the system.
3. Wait 30 seconds, and turn on the system.
4. When or after the diskette indicator appears during startup, press the F6 key on a directly-attached keyboard (or the number 6 key on an ASCII terminal).
5. Enter any requested passwords.

After any requested passwords have been entered, the system will attempt to boot from the first device of each type found on the list. If no bootable image is found on the first device of each type on the list, the system does not search through the other devices of that type for a bootable image; instead, it will poll the first device of the next type.

If all types of devices in the boot list have been polled without finding a bootable image, the system will restart, this gives the user the opportunity to start the System Management Services (by pressing the F1 key on a directly attached keyboard or the number 1 on an ASCII terminal) before the system attempts to boot again.

Custom Boot List and Default Boot List

The default boot list is:

1. Diskette
2. CD-ROM
3. Hard File
4. Network
 - Token-Ring
 - Ethernet

Pressing the F5 key on a directly-attached keyboard (or the number 5 key on an ASCII terminal) causes the system to boot in service mode from this list.

Pressing the F6 key on a directly-attached keyboard (or number 6 key on an ASCII terminal) selects a service mode boot from the custom boot list, which is the boot list defined using the System Management Services described in Chapter 5, "System Management Services" on page 5-1. Like the default boot list, the custom boot list can contain four entries. The F6 or 6 keys work like the F5 or 5 keys, with the following exceptions:

- The system will search for a boot record according to the custom boot list.
- If the custom boot list is discovered by a cyclical redundancy check to be corrupted, the system will rebuild the custom boot list according to the default boot list. (The default boot list contains four entries, and for each matching device type found in the system unit, the system makes an entry in the custom boot list.)
- If no custom boot list is present, the system enters "none" in the corresponding location within the custom boot list.

Chapter 5. System Management Services

These programs make it possible for you to view information about your system, run memory tests, and set the storage device from which the server boots.

If you have a graphical display connected to a display adapter in your system unit, then you can use the graphical System Management Services. Otherwise, you must use the text-based version of the System Management Services.

The graphical System Management Services is described in “Graphical System Management Services” on page 5-2; the text-based System Management Services is described beginning in “Text-Based System Management Services Programs” on page 5-11; the ASCII terminal is described beginning in “ASCII Terminal System Management Services Programs” on page 5-16.

To start the programs:

1. Turn on or shutdown and restart the system.
2. When the first screen appears, press the **F1** key to use the graphical System Management Services. To use the text-based System Management Services, press the **F4** key or number 4 key on an ASCII terminal.

Note: You must press **F1** or **F4** key after the diskette indicator appears on the screen, but before the last indicator appears. After you have pressed the F1 or F4 key, the initialization indicators continue to display, and the System Management Services screen displays after the last indicator.

Note: It is recommended that you create a Firmware Recovery Diskette using the Update Firmware selection in the System Management Services Tools section described in this chapter.

Graphical System Management Services

When the graphical System Management Services program begins, the following screen appears.



The System Management Services screen contains the following objects.



Start Up: This function allows you to define a custom boot list, which defines the sequence in which devices are searched by the operating system for a bootable image.



Test: Allows you to repeatedly test the memory in your system.



Tools: Enables you to set and remove passwords and to set the unattended start mode. In addition, you can view information about your system and update system programs.

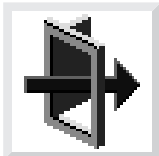

Exit: Returns you to the previous screen.

To select an object, use the arrow keys to highlight an object and then press **Enter** or the **Spacebar**. To leave the current screen, either press the **Esc** or select the **Exit** object.

Start Up

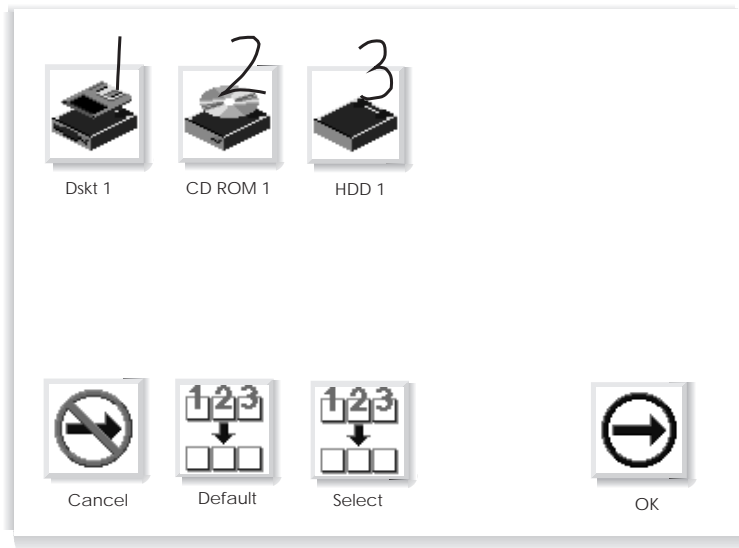

This selection enables you to define a custom boot list or reset default list, which determines the order in which devices are searched by the firmware for a bootable image. The screen may show the following objects.



Diskette: Diskette drive.



CD-ROM: CD-ROM drive.



HDD: Hard disk drive.

Highlight the device which the system will search for first when booting, and press the **Spacebar**. Notice that numbers appear over the objects, indicating the order of the startup sequence. Up to four devices can be specified. To cancel your selection, select the **Cancel** object. The **Default** object sets the sequence to:

- Diskette drive
- CD-ROM drive
- Hard disk drive
- Tape drive
- Network (if installed)

If your system has more devices than shown in the list, their objects will be displayed after those in the default sequence.

Attention: If you change your custom boot list, you must be extremely careful when doing *write* operations (for example, saving or formatting). You can accidentally overwrite data or programs if you select the wrong drive.

Test

Selecting this object enables you to test the memory in your system unit.

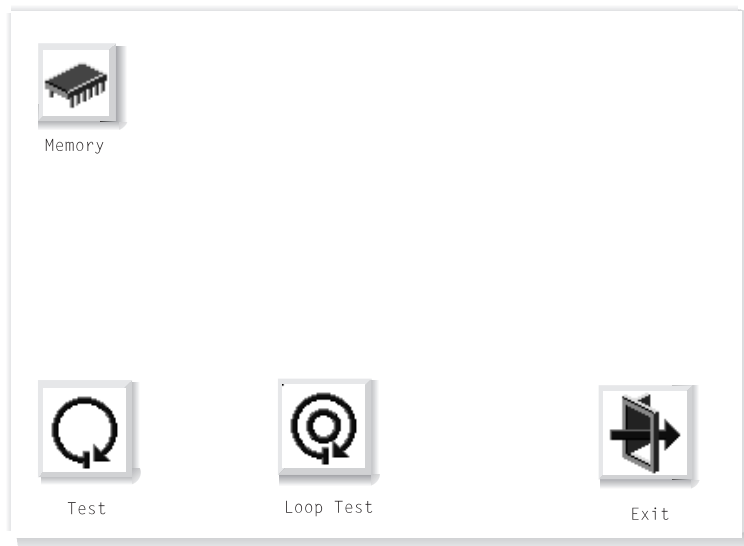

To begin the test, select the **Test** object.



The **Loop Test** object, when selected, allows the memory to be tested in a continuous loop. The test can be stopped by pressing the **S** key.



If a problem is detected during testing, an error code similar to the one below will be displayed under the object for the failing device.

00020000

If an error code appears, make a written record of the error code.

Tools

Selecting this object enables you to perform various tasks and view additional information about your system. The following screen appears with objects presented for your selection.

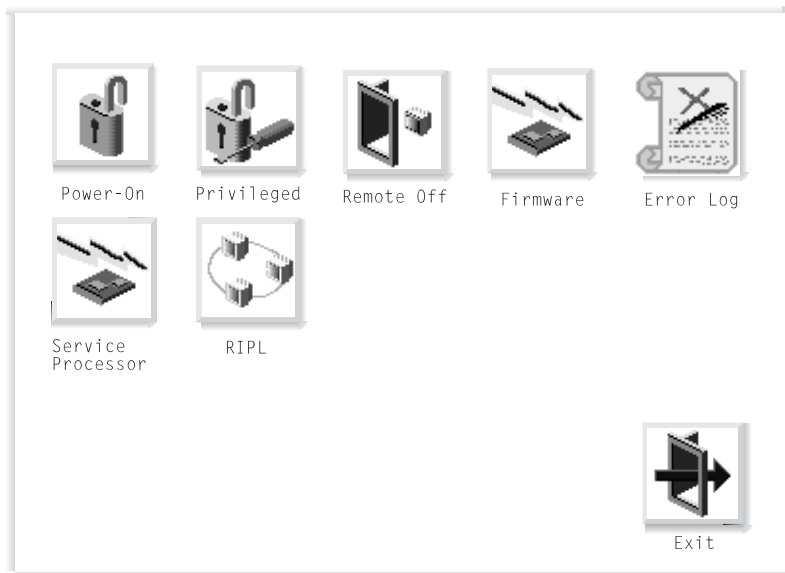

The following describes the objects on this screen.



Power-On Password: Setting a power-on password helps protect information stored in your system. When you select this object, a screen with 8 empty boxes appears. Type your password in these boxes. You can use any combination of up to eight characters (A–Z, a–z, and 0–9) for your password. As you type a character, a key appears in the box. Press **Enter** when you are finished; you will be required to type the password again for verification. If you make a mistake, select the **Cancel** object and start again.

If you already had set a power-on password and wanted to remove it, select the following object.



Note: If you *forget* your password, you will have to remove the battery for at least 30 seconds to disable the password. See “Battery” on page 7-25.

A password can be set only after system power has been turned off and then on again. You cannot set a password after using the **Ctrl+Alt+Del** combination (or *warm boot*) to restart the system.

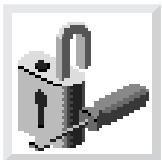

Privileged-Access Password: The privileged-access password protects against the unauthorized starting of the system programs. Follow the same procedure described for the power-on password.

As with the power-on password, you must turn system power off and then on again before setting a privileged-access password.

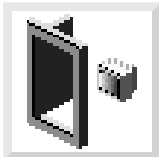

Remote Mode: The remote mode, when enabled, allows the system to start from the defined boot device. This mode is ideal for network servers and other systems that operate unattended. You *must* set a power-on password before you can enable the remote mode. When the remote mode is set, the object changes to **Remote On**.

If you remove the power-on password, the remote mode is automatically reset, and the object returns to **Remote Off**.

Selecting **Remote On** resets the startup mode to the normal startup sequence.



Firmware: Enables you to update system firmware.

Firmware should be selected only when a change to the system firmware is needed. A *Firmware Update* diskette will be made available to you when such an update is needed.

Firmware updates take several minutes, and you need a DOS formatted 1.44MB diskette. The procedure for updating the firmware is as follows.

Attention: Do not turn off power to your system during this procedure.

1. Select **Tools**, and then **Firmware**.
2. Make a backup copy of the system firmware using a DOS formatted 1.44MB diskette as prompted. This backup is a Firmware Recovery Diskette that may be used later to recover from system problems.
3. When the backup is complete, insert the *Firmware Update* diskette. The system firmware will be updated, and the system will automatically restart upon completion.



Error Log: Enables you to view error log information that is stored if an error occurs.



Service Processor: Enables you to update service processor firmware.

Service Processor should be selected only when a change to the service processor firmware is needed. A *Service Processor Update* diskette will be made available to you when such an update is needed.

Service processor updates take several minutes, and you need a DOS formatted 1.44MB diskette. The procedure for updating the service processor firmware is as follows.

Attention: Do not turn off power to your system during this procedure.

1. Select **Tools**, and then **Service Processor**.
2. Make a backup copy of the service processor firmware using a DOS formatted 1.44MB diskette as prompted. This backup is a Service Processor Firmware Diskette that may be used later to recover from system problems.
3. When the backup is complete, insert the *Service Processor Firmware Update* diskette. The service processor firmware will be updated, and the system will automatically restart upon completion.

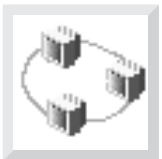

RIPL: Allows you to select a remote system to load programs from when your system is first powered on.

Overriding the Stored Boot Sequence

In order to override the stored boot sequence for the current boot, press **F5** after the keyboard indicator appears on the screen, but before the last indicator appears. This forces the firmware to search for startup code on the devices listed in the default sequence, either diskette, CD-ROM, hard disk drive, or token-ring (if installed) or ethernet (if token-ring is not installed). Pressing **F5** does not modify what has already been selected through “Start Up” on page 5-4. That information is still stored in the system. Pressing **F5** is limited to the current boot.

Text-Based System Management Services Programs

To start the programs:

1. Turn on or shutdown and restart the system.
2. As soon as the first screen appears, press the **F4** key.

Note: You must press **F4** after the diskette indicator appears on the screen, but before the last indicator appears.

The System Management Services screen appears.

```
System Management Services

Select one:

  1. Select Boot Devices
  2. Test the Computer
  3. Utilities
  4. Select Language

Enter   Esc=Quit  F1=Help  F3=Reboot  F9=Start OS
```

Use the Up Arrow and Down Arrow keys (↑ or ↓) to highlight your selection; then press **Enter**.

You can get help information about any item on a menu by highlighting the item and pressing F1. The bottom of the screen shows which keys are active.

Select Boot Devices

```
System Management Services

Select one:

  1. Select Boot Devices
  2. Test the Computer
  3. Utilities
  4. Select Language

Enter   Esc=Quit  F1=Help  F3=Reboot  F9=Start OS
```

This selection enables you to view and change the sequence in which devices are read at startup time. You also can set or change a particular startup device, or specify the device the system is to start from.

```
Boot Sequence Selection

  1. Display Current Settings
  2. Restore Default Settings
  3. Configure 1st Boot Device
  4. Configure 2nd Boot Device
  5. Configure 3rd Boot Device
  6. Configure 4th Boot Device
  7. Boot Other Device

Enter   Esc=Quit  F1=Help  F3=Reboot  F9=Start OS
```

Test the Computer

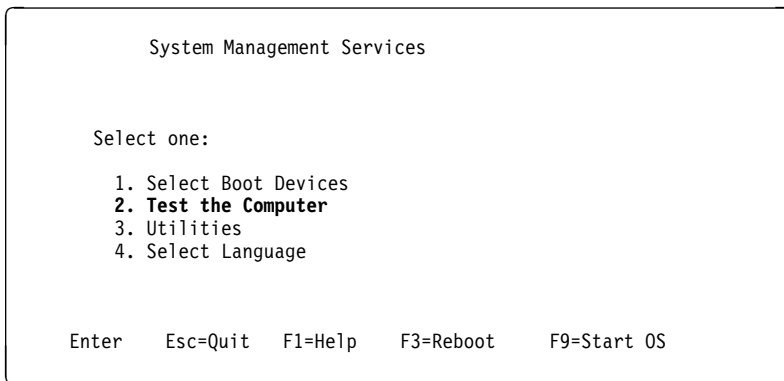

This selection enables you to test devices and functions of your system. The screen that displays, is similar to the screen that follows.

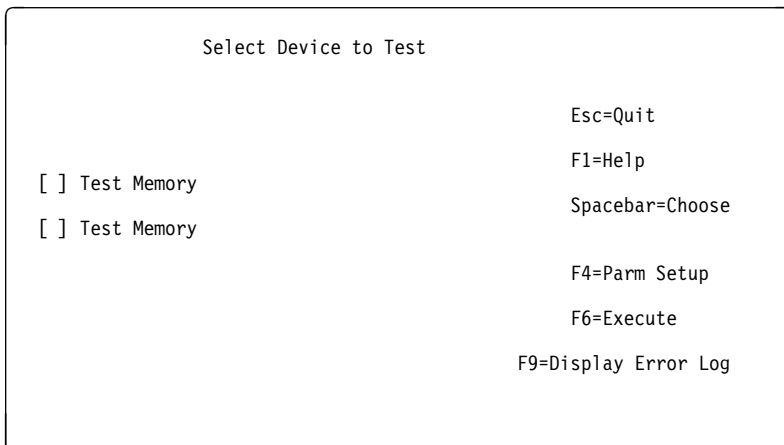

When you have selected the devices you want to test, press **F4** to set the test requirements, such as the number of times the tests are to be run, and whether testing should stop if an error occurs. After you set the requirements, press **Enter** to return to the Select the Device to Test screen; then press **F6** to start the tests.

To see if any errors were recorded in previous tests, press **F9** to display the error log.

Utilities

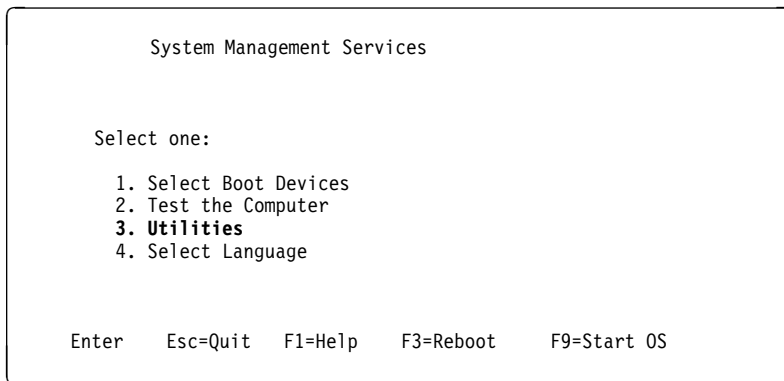

Selecting **Utilities** enables you to select from the System Management Utilities window. It has the following choices.

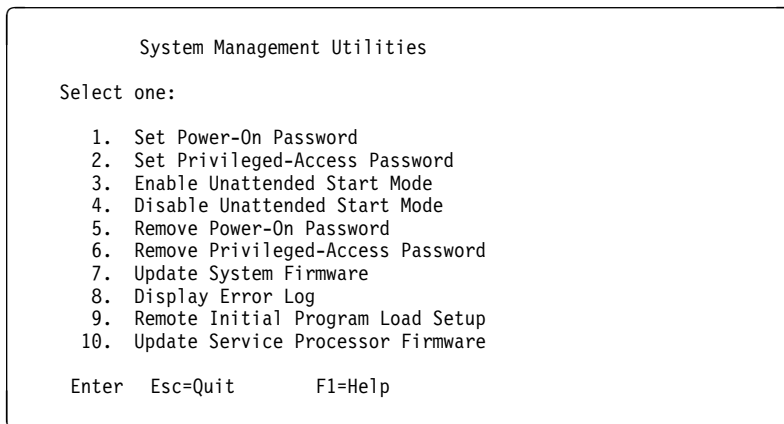

The **Power-On** and **Privileged-Access Password** are security features that help protect your system and stored information.

The **Unattended Start Mode**, when enabled, allows the system to start from the defined boot device.

Update System Firmware enables you to make these changes to the firmware of your system. To receive the latest updates, contact your authorized reseller or marketing representative. Firmware updates take several minutes, and you need a DOS formatted 1.44MB diskette. The procedure for updating the firmware is as follows.

Attention: Do not turn off power to your system during this procedure.

1. Select **Utilities**, and then **Update System Firmware**.
2. Make a backup copy of the system firmware using a DOS formatted 1.44MB diskette as prompted. This backup is a Firmware Recovery Diskette that may be used later to recover from system problems.
3. When the backup is complete, insert the *Firmware Update* diskette. The system firmware will be updated, and the system will automatically restart upon completion.

Display Error Log lets you see what problems have been recorded in previous tests.

Remote Initial Program Load Setup allows you to view parameters.

Update Service Processor Firmware enables you to make changes to the service processor firmware of your system. To receive the latest updates, contact your authorized reseller or marketing representative. Service processor updates take several minutes, and you need a DOS formatted 1.44MB diskette. The procedure for updating the firmware is as follows.

Attention: Do not turn off power to your system during this procedure.

1. Select **Utilities**, and then **Update Service Processor Firmware**.
2. Make a backup copy of the service processor firmware using a DOS formatted 1.44MB diskette as prompted. This backup is a Service Processor Firmware Recovery Diskette that may be used later to recover from system problems.
3. When the backup is complete, insert the *Service Processor Firmware Update* diskette. The service processor firmware will be updated, and the system will automatically restart upon completion.

ASCII Terminal System Management Services Programs

To start the programs:

1. Turn on or shutdown and restart the system.
2. As soon as the first screen appears, press the **1 or 4** key.

Note: You must press **1 or 4** key before the last indicator (boot) appears.

The System Management Services screen appears.

```
System Management Services

Select one:

1. Select Boot Devices
2. Test the Computer
3. Utilities
4. Select Language

Enter - q=Quit - h=Help - r=Reboot - s=Start OS - p=prev-item -
-----
n=next-item -
-----
Press enter to select item number 1.
```

Use the next (n) and previous (p) keys to make your selection; then press **Enter**.

You can get help information about any item on a menu by pressing the h key. The bottom of the screen shows which keys are active.

Select Boot Devices

```
System Management Services

Select one:

  1. Select Boot Devices
  2. Test the Computer
  3. Utilities
  4. Select Language

Enter - q=Quit - h=Help - r=Reboot - s=Start OS - p=prev-item -
-----
n=next-item -
-----
Press enter to select item number 1.
```

This selection enables you to view and change the sequence in which devices are read at startup time. You also can set or change a particular startup device, or specify the device the system is to start from.

```
Boot Sequence Selection

1. Display Current Settings      Enter -
2. Restore Default Settings    -----
3. Configure 1st Boot Device    q=Quit -
4. Configure 2nd Boot Device    -----
5. Configure 3rd Boot Device    h=Help -
6. Configure 4th Boot Device    -----
7. Boot Other Device           p=prev-item -
                                -----
                                n=next-item -
                                -----

Press enter to select item number 1.
```

Test the Computer

```
System Management Services

Select one:

1. Select Boot Devices
2. Test the Computer
3. Utilities
4. Select Language

Enter - q=Quit - h=Help - r=Reboot - s=Start OS - p=prev-item -
-----
n=next-item -
-----
Press enter to select item number 2.
```

This selection enables you to test devices and functions of your system. The screen that displays, is similar to the screen that follows.

```
Select Device to Test

[>] Test Memory

1. Test Memory

q=Quit -
-----
h=Help -
-----
Spacebar=Choose -
-----

p=Parm Setup -
-----
E=Execute -
-----
d=Display Error Log -
-----
```

When you have selected the devices you want to test, press **p** to set the test requirements, such as the number of times the tests are to be run, and whether testing should stop if an error occurs. After you set the requirements, press **Enter** to return to the Select the Device to Test screen; then press **E** to start the tests.

To see if any errors were recorded in previous tests, press **d** to display the error log.

Utilities

```
System Management Services

Select one:

  1. Select Boot Devices
  2. Test the Computer
  3. Utilities
  4. Select Language

Enter - q=Quit - h=Help - s=Start OS - p=prev-item - n=next-item -
-----
Press enter to select item number 3.
```

Selecting **Utilities** enables you to select from the System Management Utilities window. It has the following choices.

```
System Management Utilities

Select one:

  1. Set Power-On Password
  2. Set Privileged-Access Password
  3. Enable Unattended Start Mode
  4. Disable Unattended Start Mode
  5. Remove Power-On Password
  6. Remove Privileged-Access Password
  7. Update System Firmware
  8. Display Error Log
  9. Remote Initial Program Load Setup
 10. Update Service Processor Firmware

Enter - q=Quit - h=Help - r=Reboot - p=prev-item - n=next-item -
-----
Press enter to select item number 1.
```

The **Power-On** and **Privileged-Access Password** are security features that help protect your system and stored information.

The **Unattended Start Mode**, when enabled, allows the system to start from the defined boot device.

Update System Firmware enables you to make these changes to the firmware of your system. To receive the latest updates, contact your authorized reseller or marketing representative. Firmware updates take approximately 30 seconds, and you need a DOS formatted 1.44MB diskette. The procedure for updating the firmware is as follows.

Attention: Do not turn off power to your system during this procedure.

1. Select **Utilities**, and then **Update System Firmware**.
2. Make a backup copy of the system firmware using a DOS formatted 1.44MB diskette as prompted. This backup is a Firmware Recovery Diskette that may be used later to recover from system problems.
3. When the backup is complete, insert the *Firmware Update* diskette. The system firmware will be updated, and the system will automatically restart upon completion.

Display Error Log lets you see what problems have been recorded in previous tests.

Remote Initial Program Load Setup allows you to view parameters.

Update Service Processor Firmware enables you to make these changes to the system processor firmware of your system. To receive the latest updates, contact your authorized reseller or marketing representative. Service processor updates take several minutes, and you need a DOS formatted 1.44MB diskette. The procedure for updating the firmware is as follows.

Attention: Do not turn off power to your system during this procedure.

1. Select **Utilities**, and then **Update Service Processor Firmware**.
2. Make a backup copy of the service processor firmware using a DOS formatted 1.44MB diskette as prompted. This backup is a Service Processor Firmware Recovery Diskette that may be used later to recover from system problems.
3. When the backup is complete, insert the *Service Processor Firmware Update* diskette. The service processor firmware will be updated, and the system will automatically restart upon completion.

Chapter 6. Firmware

The firmware is organized into three major sections:

- **Boot Block:** Receives control at power on, and is able to perform a soft firmware recovery from diskette when necessary.
- **Firmware Core:** Brings the system up to where the compressed image has been decompressed into memory and running.
- **Virtual Disk:** Contains the firmware modules required to support each hardware subsystem.

Boot Block

- Power-On the system, the power **LED** begins to glow on the front panel.
- Hardware passes control to storage address 0xFFFF00100, the firmware entry point.

Processor POST

- An uncompressed instruction -- "Branch to the System Environment" resides at address 0xFFFF00100. This will test that "Branch" works. If it fails, then the next instruction is executed(which is data). A program check interrupt occurs, where another branch is encountered followed by a program check. The system has essentially come to a **STOP**, with no signs of life (no beep, no hard file LED).
- At the branch target address -- initialize the 60X Processor Registers.
- If the 60X fails, the code will **STOP** by performing a Branch to itself instruction. The system will appear to be doing nothing; but cooling fans might be observed running.

Setup the Firmware Environment

Prepare for the compressed image of the firmware to be uncompressed and run from memory by doing the following:

1. Initialize the memory controller; find a small amount of good memory.
2. When no memory to configure then turn on the hard file **LED** and **STOP**.
3. Setup the C Environment in the small amount of good memory.
4. Everything is going OK so give **One Short Beep** on the speaker.
5. Check CRC of the compressed firmware.

Firmware Core

Establish Active RAM Area

1. Copy a part of the firmware code into the small amount of memory.
2. Run the firmware code now in the memory's C environment. The RAM POST will test and configure larger amount of good memory.
3. When larger amount of memory is not found, then the hard file **LED** is activated and the system is made to **STOP**. At this point there has been a beep and now the hard file LED is has been lit, and the system is halted.
4. The L2 CACHE POST executes. If it passes, everything is OK. If it fails the system does not stop, nor beep, but there is an indicator set so that when the display is available and the RAM POST is testing the remainder of memory, there is an icon with the 8 digit error code -- 01291000 displayed; to see where timing of the icon appears with respect to the firmware flow -- see "Load the Virtual Disk," item 3g on page 6-3. If a ASCII terminal is present there is a window with the error code.
5. Copy the compressed firmware code into the larger amount of good RAM and uncompress.
6. Setup a new C Environment in the larger amount of good memory; a user stack, an interrupt stack, and a debugger stack, plus a TOC pointer.

Virtual Disk

Initialize Individual Subsystems

- Bring the VDISK Online.
- UART initialization. If NVRAM BAD CRC error -- display with 8 digit error code 0x00016000.
- PCI setup
- Interrupts initialization -- interrupts are not tested. SMS program only tests RAM.
- Real time clock initialization
- Keyboard/Mouse controller (8042 chip) initialization
- Password initialization
- Debugger initialization

Load the Virtual Disk

1. Manager (system level) initialization
2. VDISK file system initialization
3. Run V: autoexec.6md (Resident Monitor) to Load all DEVICE drivers
 - a. video -- initialize ASCII terminal and/or VGA adapter
 - as -- Async Console Support (ASCII terminal S1 serial port)

- Execute the VGA adapter POST(s). If there is an error then issue **One Long Beep and One Short Beep** on the Speaker, and continue.
 - PCI graphics POST and initialization.
- b. On VGA display the "Brand" Logo, or POST indicators on ASCII terminal.
- c. Icons will start appearing on the VGA.
- d. Keyboard icon appears -- initialize the keyboard and mouse.
- e. The window for pressing the F1 (GUI) or F4 (English) keys is now open.
- f. The Diskette icon appears -- initialize the adapter.
- g. Extended memory icon -- test the remainder of memory. Memory module failures are displayed on the VGA as a triangle with an "!" inside and an 8 digit error code -- 00020000 or if L2 Cache failed, the same triangle displays with the 8 digit error code 01291000. On an ASCII terminal there is no triangle and an 8 digit error code message will display.
- h. The SCSI icon appears while adapters are being initialized. SCSI, Ethernet, pci_c970, trpci, tcpip -- initialize Network when present.
- i. The last icon -- the boot disk icon is displayed. If the graphics screen gets cleared, then none of the previous icons will get re-displayed until the next boot of the system.
- j. **One Long Beep** on the Speaker.
- k. If the "Power-On Password" (**POP**) or the Privileged Access Password (**PAP**) option(s) are in effect then the Password screen appears; enter the password and press enter. Three attempts are allowed to enter the correct password before the system locks up and gives the PAP 8 digit error code 00016004 or the POP 8 digit error code 00016005. The only recovery for password 8 digit error code is to cycle system power. See "Power On Password" on page 6-7 and see "Privileged Utilities Password" on page 6-7 for more information about passwords.

Attention: If no one is able to provide the password, the only recovery is to remove the NVRAM Battery for awhile; this could be detrimental to the customer, any data in NVRAM could be corrupted, and may have to be regenerated by the customer. One item might be the preferred/service bootlist.

Start of boot sequence boot(0)

- Boot using the custom bootlist set by the SMS utility.
- See "Function Keys" on page 6-5 for information on how to choose a boot path device along with Normal and Service mode.

End of boot sequence boot(0)

- On the VGA only the icons are cleared from the screen.

Firmware Beeps

The firmware will use the speaker as a means to communicate the result of certain tests. The following list describes the type of beeps.

- **No Beeps:** This is a hardware failure not involving the firmware. "The speaker may be bad or disconnected, or the system board may be bad."
- **One Beep:** Has been redefined as:
 - **One Short Beep(9/32 sec.):** Is used at Power-On when the hardware passes control to the firmware.
 - **One Long Beep(1 3/4 sec.):** It means initialization completed and no fatal errors occurred, so continue the boot process.
- **Continuous Beep:** This is a hardware failure not involving the firmware. "The system board has a failing component or a failure related to the speaker subsystem has occurred."
- **One Long and One Short Beep:** Firmware "... has detected an error on the video adapter card. ..."

Console Strategy

If the graphics adapter is present, the user interface will be GUI. If the graphics adapter is NOT present AND there is an active device in Serial Port 1, the active device will be assumed ASCII terminal, and the user interface will be text. The user interface will be either the graphics system or the ASCII terminal, but NOT BOTH. Graphics interface will default to GUI with the option to switch to text. ASCII terminal interface will always be text. The PF keys will not be used to initiate Maintenance Mode on ASCII terminal consoles, numeric keys will be used instead (see key equivalent in each PF key definition below).

Normal Mode Boot Responses

The following assumes successful entry of the Power On Password (POP) if set. This applies to both normal and service modes.

In the case that no boot device is found during a normal boot attempt, the firmware will request the PAP if set, then it will initiate the System Maintenance Services (SMS).

If the custom bootlist is discovered to be CRC corrupted, Firmware will rebuild the custom bootlist according to the default boot list. The custom bootlist is four deep, and for each matching device type found to be present in the system, firmware

makes an entry in the custom bootlist. If a default boot list device is missing from the system, firmware enters 'none' in the corresponding location of custom bootlist.

Function Keys

PF1 Key

- PF1, when operated from a directly attached keyboard, will invoke the System Management Services (SMS) GUI interface.
- The "key-switch" will be set to **Normal mode**.
- Numerical **1 key** will be the equivalent key on an ASCII terminal. The result, however, will be the same as the function of PF4, as described below.

PF4 Key

- PF4, when operated from a graphics console, will invoke the SMS program and present the text interface.
- The "key-switch" will be set to **Normal mode**.
- Numerical **4 key** will be the equivalent key on an ASCII terminal.

PF5 Key

- The default boot list, located in firmware, will be used.
- The "key-switch" will be set to **Service mode**.
- Numerical **5 key** will be the equivalent key on an ASCII terminal.

This mode will attempt to boot from the first device of each type found in the list. It will not search for other bootable devices of that type if the first device is not bootable. It will, instead, continue to the next device type in the list. If after one pass through the boot list no boot record is found, Firmware will invoke the SMS program. The firmware supports up to four entries in the boot list.

The default boot order is:

1. Diskette
2. CD ROM
3. Hard File
4. Tape Drive
5. Network
 - a. Token Ring
 - b. Ethernet

PF6 key: PF6 will work like PF5 with some exceptions

- Firmware will look for a boot record according to the custom bootlist that was setup by System Management Services.

- If after one pass through the custom bootlist no boot record is found, firmware will invoke the SMS program.
- The "key-switch" will be set to **Service mode**.
- Numerical **6 key** will be the equivalent key on an ASCII terminal.

Password Design Description

Password Design Overview

The owner of the system has the option to limit access to the system. The system limits access by requiring the user to enter a password. There are three categories of restricted access.

The first category is power-on. If this category is enabled, the system will prompt the user to enter the Power-On password (POP) when the system is powered on. The user must supply the Power-On password.

The second category is privileged access. Privileged access is needed to perform functions on the SMS, or boot from a device that isn't in the boot path. When the user attempts to do one of these things, the system will prompt for the Privileged Access Password (PAP). The user must supply the PAP.

The third category is unattended start mode. In unattended start mode, the system will boot from a defined boot device, but the keyboard will be locked until the user enters the Power-On password.

Enabling Security

Utilities are provided to allow the system owner to enable any of the above security modes and to enter or change the Power-On or Privileged-Access passwords. The passwords can be up to 8 characters long. After entering a password, the user is prompted to verify it by entering it a second time. After the password has been entered two consecutive times, it is saved in CMOS.

Storing of Password

The POP and PAP are stored in CMOS. The time that each password was saved, and the time that each password is read is also stored. If for any reason the contents of CMOS are suspect (bad battery or CRC), the passwords will be considered valid, but unusable. The areas in CMOS that contain the password are locked before the operating system is booted. After the passwords have been locked, the user must power off the system before the passwords can be accessed again.

Power On Password

When the system is powered on, it will check whether a Power-On password is present. If there is one present, and unattended start mode (see “Unattended Start Mode” on page 6-7) is not set, the owner has specified that the system cannot be used unless the Power-On password is supplied. The system prompts for the Power-On password. The user is given three attempts to enter the password. If the user fails to supply the password, the system will go to a hang state and must be powered off before continuing.

Privileged Utilities Password

If a user wants to boot, change or remove the Privileged-Access password, or use any of the other “Privileged” utilities, the system will check whether a Privileged Access password exists. If it does, the user is prompted to either enter the Privileged Access password. The user is given three tries to supply the correct password. If the user fails to do so, the system will go to a hang state and must be powered off before continuing.

Unattended Start Mode

If Unattended Start Mode is enabled, the system will boot from the defined boot device without requiring any input from the user. The keyboard controller will be programmed to lock up until the Power-On password is entered.

Firmware Flash Update Design

The firmware flash update can be performed in normal mode and recovery mode. The type of update mode will determine what portions of the flash code is updated, whether the update is done "quietly" (no messages), and whether the original VPD information is merged into the new image before updating.

The default is a "normal" update, where the firmware flash update is performed from the System Management Services Menu. Messages and errors are communicated through the menu pop-up interface. The system user selects the Update Firmware option, and the composite image is loaded using the default file name and default media. The original system VPD information is merged in before the image is programmed. Only the sectors containing the composite image are programmed; those containing the recovery block are considered "read-only".

A "recovery" update, is executed automatically when a bad composite image is detected during early system initialization. Most messages and errors are suppressed; fatal errors are displayed in a serial interface compatible format. The default file name and default flash update media is assumed. The selected media

drive (diskette drive) is continuously polled until a valid firmware image can be found and loaded. The original system VPD information is merged in before the composite image is programmed. The recovery block flash sectors are not modified during a recovery update.

For any update, the firmware flash update routine checks if the system flash part can be updated. The flash ID and sector protection bits are retrieved from the part. If the flash ID could not be read or the flash ID indicates an unsupported part, then the update routine is terminated. If the ID indicates a supported part, then the sector programming data structures are initialized. The sector protection bits are examined, to ensure that the sectors to be updated are not write-protected. If a sector to be updated is write-protected, then the update routine is terminated. If the flash part passes all of these validity tests, then the routine moves onto file operations.

The firmware flash update routine checks the selected flash media for the flash file. If the file is located and loaded successfully from the media, it is then examined to ensure it is a valid firmware image. A firmware image is verified by checking if it has a valid CRC, valid file length, valid flash table/system ID structure. If the firmware image could not be loaded or is invalid, then the update routine is terminated.

For normal or recovery mode, once a valid firmware image is loaded successfully, the VPD information is merged from the flash ROM to the image. The VPD information is duplicated in the recovery block and composite image, which ensures that there is a protected copy of the VPD in case the composite image is corrupted.

Now that the firmware image is ready for programming, the firmware flash update routine begins the section of code that erases and programs the flash part. During this section of code, a system power-down results in a corrupted flash ROM. Notice that for normal and recovery mode, only the composite image sectors are erased and reprogrammed, so those sectors would be the only ones that could be corrupted. Since the recovery block is protected in these modes, the system can still be restored through a recovery flash update. A system power down at the wrong time could result in a completely corrupted flash ROM and a dead system. To minimize the risk when in text mode, the routine displays a message warning the user "Flash update in progress. Do not power down the system...".

Before the flash part can be programmed with the new image, the firmware flash update routine must erase the appropriate sectors. For all modes, the composite image sectors are erased and reprogrammed first. If an erase operation fails, it is retried according to the flash part spec. If the flash part won't erase even after retries, the update routine is terminated. If the erase operation was successful, the firmware flash update routine programs the composite image into the corresponding flash sectors. If a byte in the flash part cannot be programmed with a new value, even after the specified retries, the update routine is terminated. If the composite

image was programmed successfully, the routine checks if it still needs to update the recovery block portion.

The firmware has now been successfully updated. The firmware flash update routine removes any "in process" messages, performs some general clean-up and then reboots the system. Once the system is re-booted, the new flash image is active and executed.

Power On Self Test (POST)

Processor POST:

The firmware tests the processor. If there is a failure the system will Check-Stop (stop) and the initial beep of the speaker will not be heard.

Memory Module and L2 cache POST:

The firmware RAM POST will test all of memory; it is done in segments. After the initial short beep, if the system stops with the hard file indicator on solid, then this is the indication that no memory was found.

If any memory is found then a small segment is used. If the segment cannot be found then the system stops with the hard file indicator on solid.

A larger amount of memory is tested for stuck or coupled bits. The L2 cache is tested, if it fails there will be a momentary indication when the display becomes available, the error is also put in the SMS error log.

During system initialization when icons are being displayed for the various components of the system, one of the icons will be the memory module icon. During display of this icon an L2 cache, 8 digit error code would be displayed if L2 is not fully functional; also the remainder of memory is tested and if a failure is detected, an 8 digit error code is posted. This error indicates which memory module slot is at fault.

A separate memory test is provided in the System Management Services (SMS). This test can be made to loop. It tests memory similar to the POST and will also give an 8 digit error indications for the memory module slot. The L2 cache is not retested in the SMS memory test.

Update Flash CRC

The firmware will perform a Cyclic Redundancy Check (CRC) on the update portion of the flash module. If the check is not good, the firmware goes into recovery mode. This mode is recognized by the hard file indicator being on continuously (or blinking), and the diskette drive indicator blinking periodically.

Video/Graphics Adapter POST:

The firmware does test the VGA adapter but not the display. The system gives a speaker beep sequence when the VGA adapter is found to be non-functional. The beep sequence is a one long beep followed by one short beep; the error is logged and the system continues.

SCSI subsystem POST:

The SCSI POST opens the adapter and runs several test scripts which check and exercise the various functions related to the chips on the SCSI adapter, such as DMA, and simulate mailbox commands. If an error is detected, an 8 digit error code is displayed, and the error is entered in the SMS error log and the system continues.

Keyboard/Mouse Adapter:

The keyboard/mouse adapter has a built in power on test, and the firmware checks the results. If an error is detected, an 8 digit error code is displayed and the error is entered in the SMS error log and the system continues.

Post Indicators

When the POST is finished, the following screen displays.

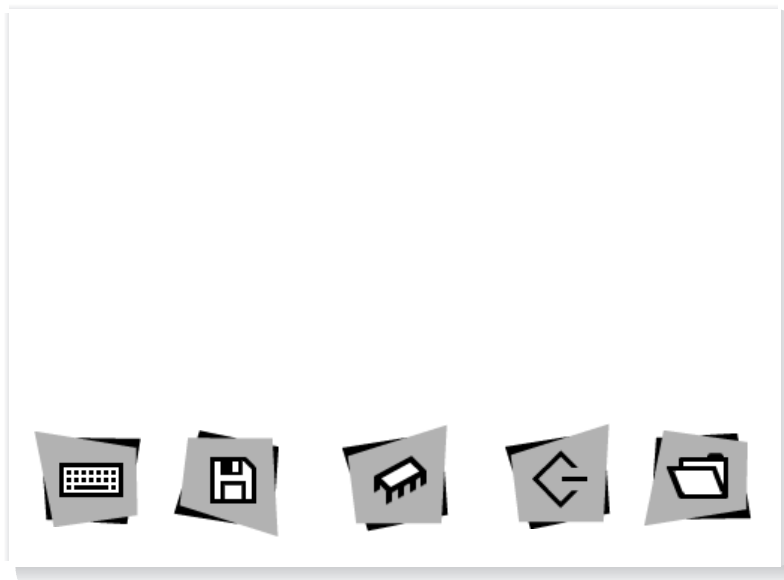

The POST screen displays the following objects.



Keyboard: Initialize the keyboard and mouse. The window for pressing the F1 (GUI) and F4 (English) keys is now open.



Diskette: Initialize the adapter.



Memory Module: Test all memory greater than 3 Meg.



SCSI: Adapters are being initialized. Network is also initialized if present.



Boot Disk: System is attempting to boot from the default boot list.

If using an ASCII terminal, the following text is displayed.

- dskt
- mem
- scsi
- boot

If the POST completes successfully, the text will display "OK" such as dskt OK.

Chapter 7. Removal and Replacement Procedures

Before performing any of the removal or replacement procedures in this chapter, read the following notice.

DANGER

An electrical outlet that is not correctly wired could place hazardous voltage on metal parts of the system or the devices that attach to the system. It is the responsibility of the customer to ensure that the outlet is correctly wired and grounded to prevent an electrical shock.

Before installing or removing signal cables, ensure that the power cables for the system unit and all attached devices are unplugged.

When adding or removing any additional devices to or from the system, ensure that the power cables for those devices are unplugged before the signal cables are connected. If possible, disconnect all power cables from the existing system before you add a device.

Use one hand, when possible, to connect or disconnect signal cables to prevent a possible shock from touching two surfaces with different electrical potentials.

During an electrical storm, do not connect cables for display stations , printers, telephones, or station protectors for communications lines.

CAUTION:

This product is equipped with a 3-wire power cable and plug for the user's safety. Use this power cable in conjunction with a properly grounded electrical outlet to avoid electrical shock.

Handling Static-Sensitive Devices

Attention: Adapters, planars, diskette drives, and disk drives are sensitive to static electricity discharge. These devices are wrapped in antistatic bags, as shown in this illustration, to prevent this damage.

Take the following precautions:

- If you have an antistatic wrist strap available, use it while handling the device.
- Do not remove the device from the antistatic bag until you are ready to install the device in the system unit.
- With the device still in its antistatic bag, touch it to a metal frame of the system.
- Grasp cards and boards by the edges. Hold drives by the frame. Avoid touching the solder joints or pins.
- If you need to lay the device down while it is out of the antistatic bag, lay it on the antistatic bag. Before picking it up again, touch the antistatic bag and the metal frame of the system unit at the same time.
- Handle the devices carefully in order to prevent permanent damage.

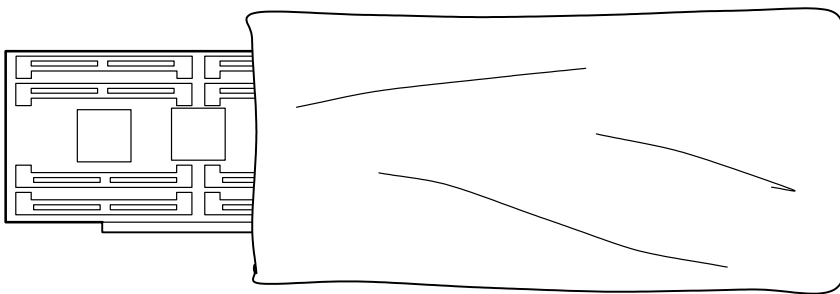

Acclimation

Before using a drive or cartridge, always let these items adjust (acclimate) to the operating environment by placing the drive or cartridge in the operating environment for as long as it was away from this environment, or for 24 hours.

Acclimation is necessary for any device or cartridge that is exposed to a different environment or temperature change of 11°C (20°F).

Covers

Removal

1. Remove all media (diskettes, CD-ROMs, or tapes) from the drives.
2. Shut down the system unit:
 - a. If the operating system is responding to commands, enter the correct **shutdown** command. Failure to do so may result in loss of data. If you need information on the shutdown procedure for your operating system, refer to your operating system documentation.
 - b. After you shut down the operating system, set the power switches of the attached devices to Off.
 - c. Turn off the system unit.
 - d. Open the door.

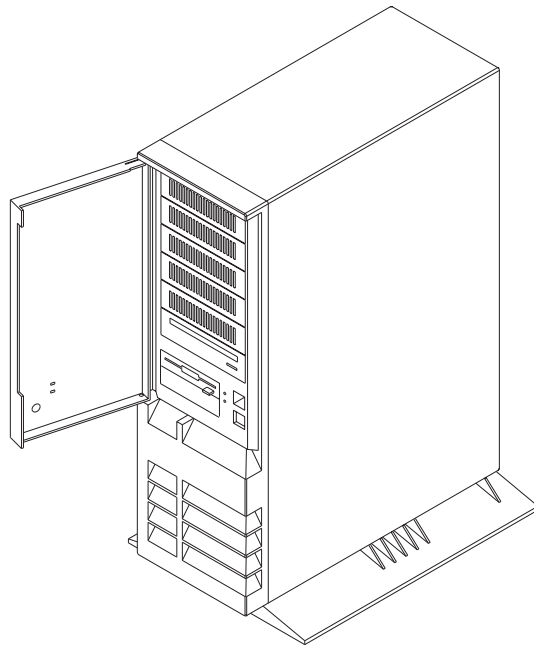

- e. If you have a modem or fax machine attached to the server, disconnect the telephone line from the wall outlet and the server.
- f. Unplug all power cords (cables) from electrical outlets.

g. Note the locations of the following; then, disconnect them from the back of the server:

- Power cord
- Display cable
- Keyboard cable
- Any other cables and cords

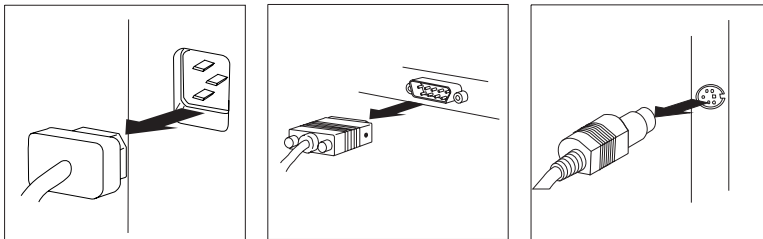
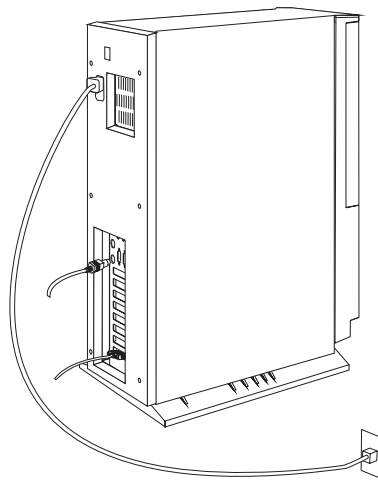

h. Remove the cover:

- 1) Loosen the six screws in the recessed holes on the back of the cover.

Note: The screws stay in place; do not attempt to remove them.

- 2) Grasp the sides of the cover, pull it back slightly, then tilt it back a few inches.
- 3) Grasp the cover at the top front edge with one hand, and just above the I/O slots with the other hand.
- 4) Remove the cover gently, in a rotating motion, as shown.
- 5) Store the cover in a safe place.

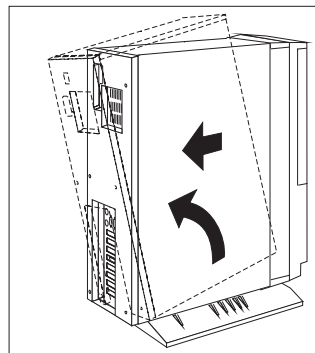
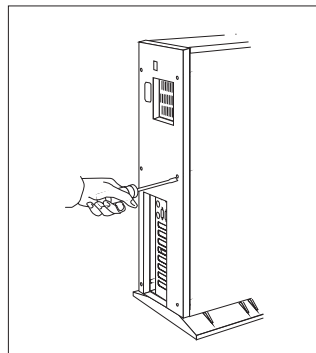
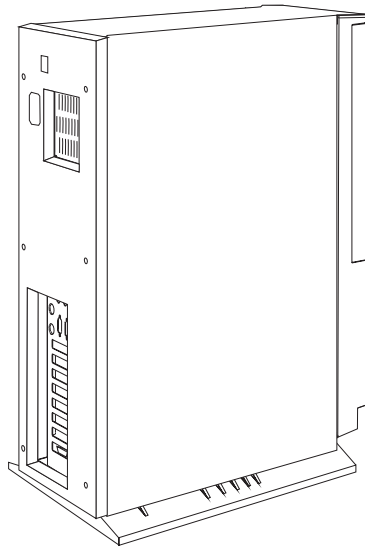

Replacement

To replace the cover, perform the removal steps in reverse order.

Power Supply

DANGER

Do not attempt to open the covers of the power supply. Power supplies are not serviceable and are to be replaced as a unit.

Removal

1. If you have not already done so, remove the covers as described in “Covers” on page 7-3.
2. Disconnect all leads from the power supply to the drives in bays 1 through 8.
3. Disconnect all leads from the power supply to the system planar.
4. While supporting the power supply with one hand, remove the four screws securing the power supply to the rear of the system unit.

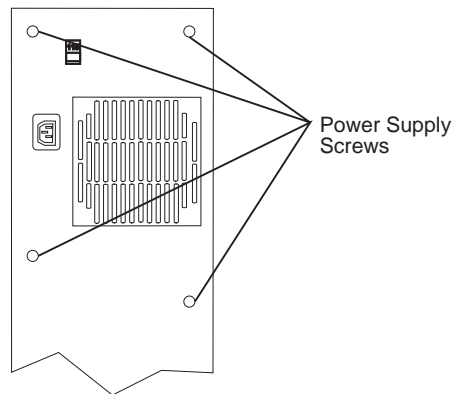

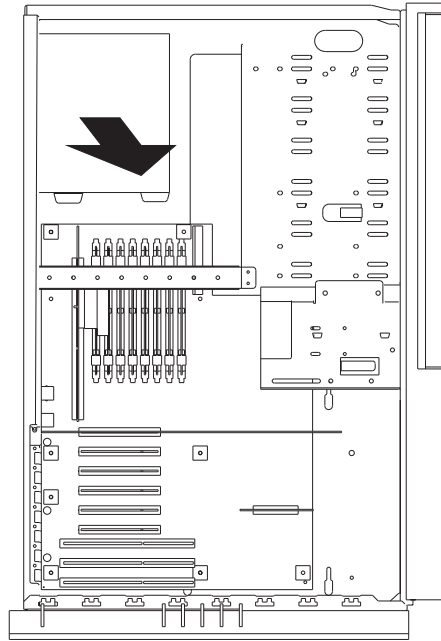

Replacement

To replace the power supply, perform the removal steps in reverse order.

Note: Make sure that the voltage switch setting on the new power supply matches the voltage provided by the electrical outlets.

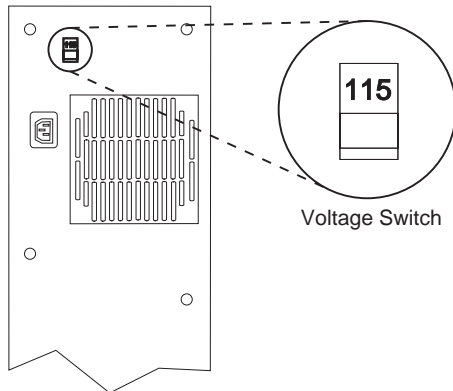

Media Drive in Bays 3 through 8



CAUTION:

A class 3 laser is contained in the device. Do not attempt to operate the drive while it is disassembled. Do not attempt to open the covers of the drive as it is not serviceable and is to be replaced as a unit.

Removal

1. If you have not already done so, remove the covers as described in “Covers” on page 7-3.
2. Remove the cover plate from the target bay if installed:
 - a. Insert a small flat-blade screwdriver under the side of the cover plate.
 - b. Lift the cover plate and remove it from the server's front panel. (Save the cover plate for future use.)

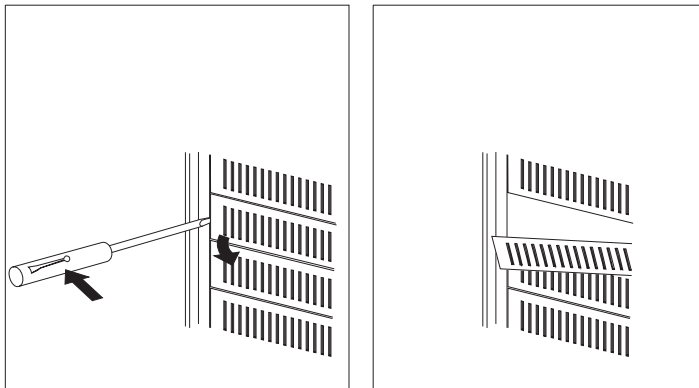

3. Complete the following steps:
 - a. Find the drive you plan to remove.
 - b. Disconnect the cables (signal and power) from the rear of the drive.
 - c. If you are removing a 3.5-inch drive, remove the screws that hold the drive tray in place. Then remove the drive from the tray.
 - d. If you are removing a 5.25-inch drive, slide the drive out of the bay.

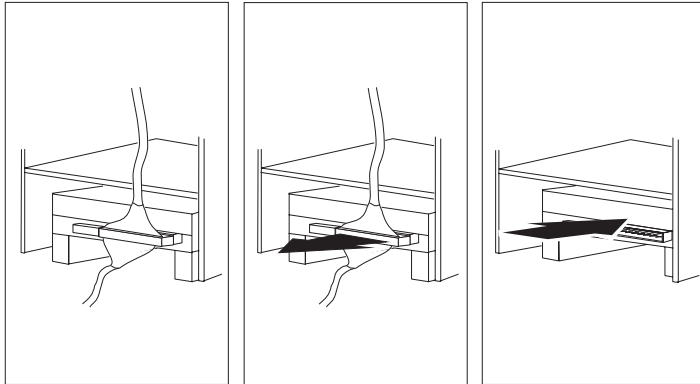

4. Note the setting of the SCSI address jumpers of the drive you have just removed.
5. If you are not installing a replacement drive, reinstall the cover plate:
 - a. Locate the original blank cover plate that was shipped with your server.
 - b. Insert the tabs on the right end of the cover plate into the target bay opening in the server's front panel.
 - c. Pivot the plate and press it into place.

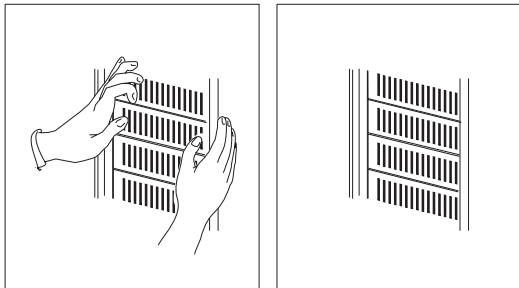

Replacement

To replace a media drive, perform the removal steps in reverse order.

Note: Be sure to set the SCSI address jumpers of the new drive to match those of the drive that was just removed.

Diskette Drive and Lower Hard Disk Drive

1. If you have not already done so, remove the covers as described in “Covers” on page 7-3.
2. Remove the three screws that secure the airflow baffle to the system chassis, slide the airflow baffle to the front of the system unit, and remove the airflow baffle.

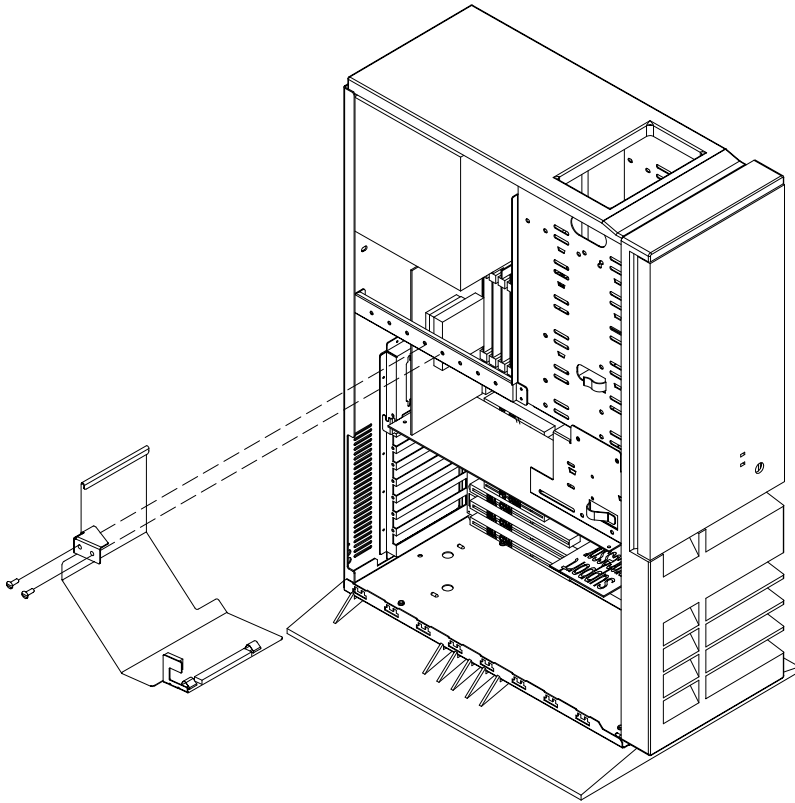

3. Remove the operator panel display as described in “Operator Panel Display” on page 7-28.

4. Remove the four screws from the drive housing containing bays 1 and 2.

Note: Three screws are shown near the screwdriver in the following illustration. The fourth screw is located under the housing, on the left-hand side.

5. Gently pull the housing away from the bracket that holds its other side in place.

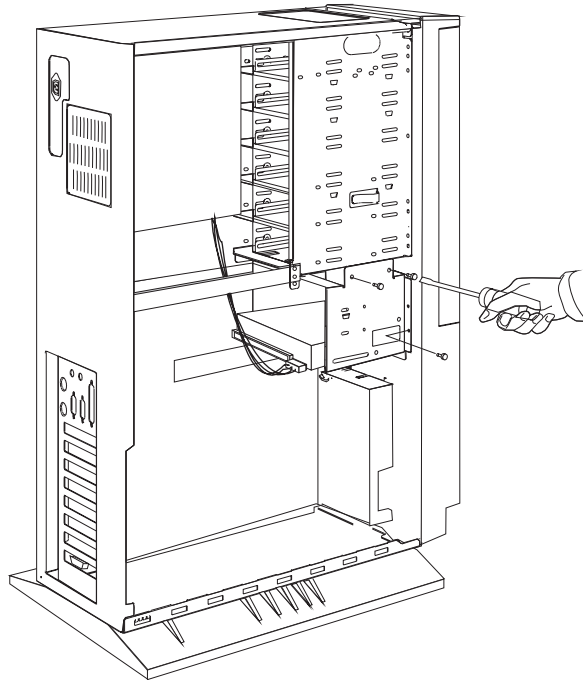

6. To remove a drive from bay 1 or 2, complete the following steps:
 - a. Find the drive you plan to remove.
 - b. Disconnect the cables (flat and power) from the rear of the drive.
 - c. Remove the screws that hold the drive in the housing.
 - d. Slide the drive out of the bay.
7. If you are replacing a disk drive from bay 1, note the SCSI address of the disk drive you just removed.

Replacement

To replace a diskette or lower hard drive, perform the removal steps in reverse order.

Note: If you are replacing a disk drive in bay 1, make sure the address of the new drive matches the address of the drive you just removed.

Adapters

Removal

1. If you have not already done so, remove the covers as described in "Covers" on page 7-3.
2. Note the slot number of the adapter you are removing.

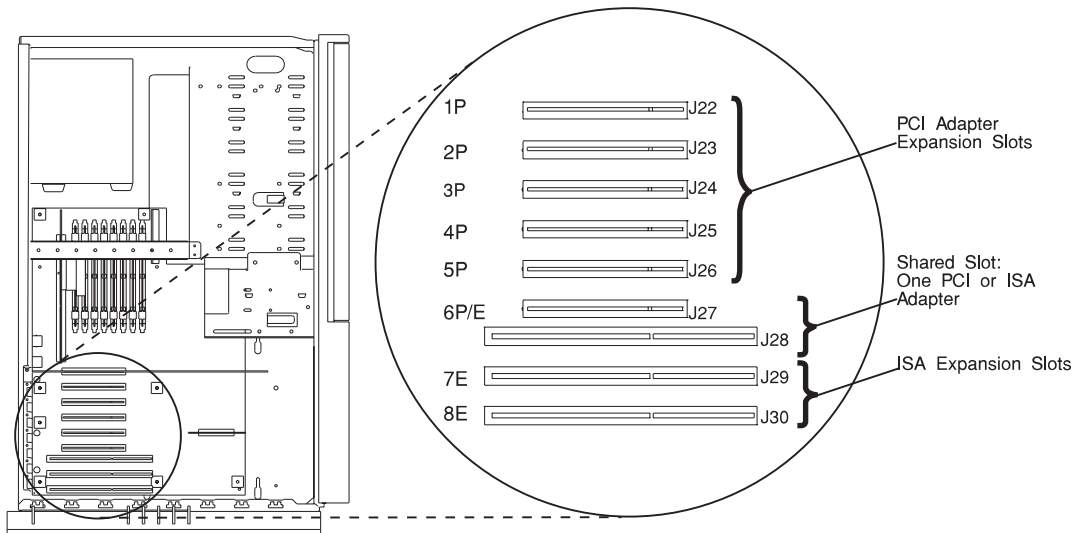

3. Loosen and remove the screw on top of the adapter's bracket.

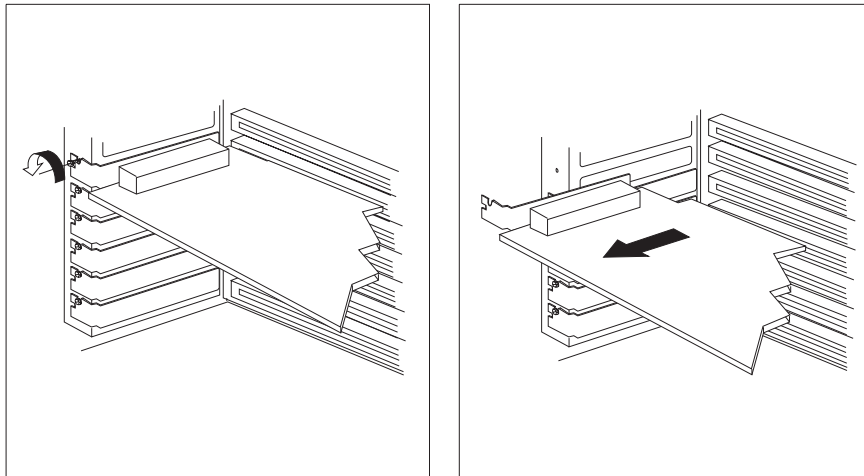

4. If there are any internal cables attached to the adapter, disconnect them.

5. Put one hand on top of the server for support, and with the other hand, carefully pull the adapter out of the slot.
6. If you are installing another adapter in this expansion slot, follow the instructions given under “Replacement.”
7. If you are not installing another adapter in this expansion slot, replace the expansion-slot cover:
 - a. Slide the cover over the open expansion slot.
 - b. Tighten the expansion-slot screw on the top of the expansion-slot cover.

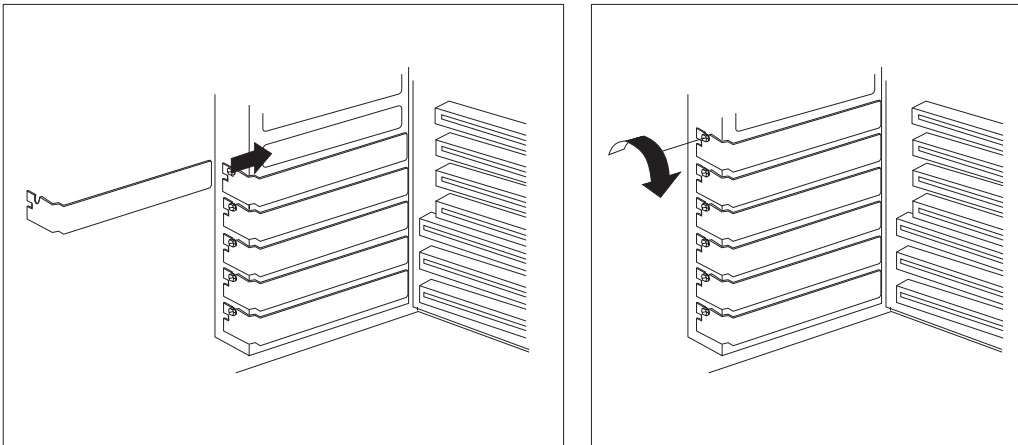

Replacement

To replace an adapter, perform the removal steps in the reverse order.

Memory Modules

Removal

1. If you have not already done so, remove the covers as described in “Covers” on page 7-3.
2. Remove the three screws that secure the airflow baffle to the system chassis, slide the airflow baffle to the front of the system unit, and remove the airflow baffle.

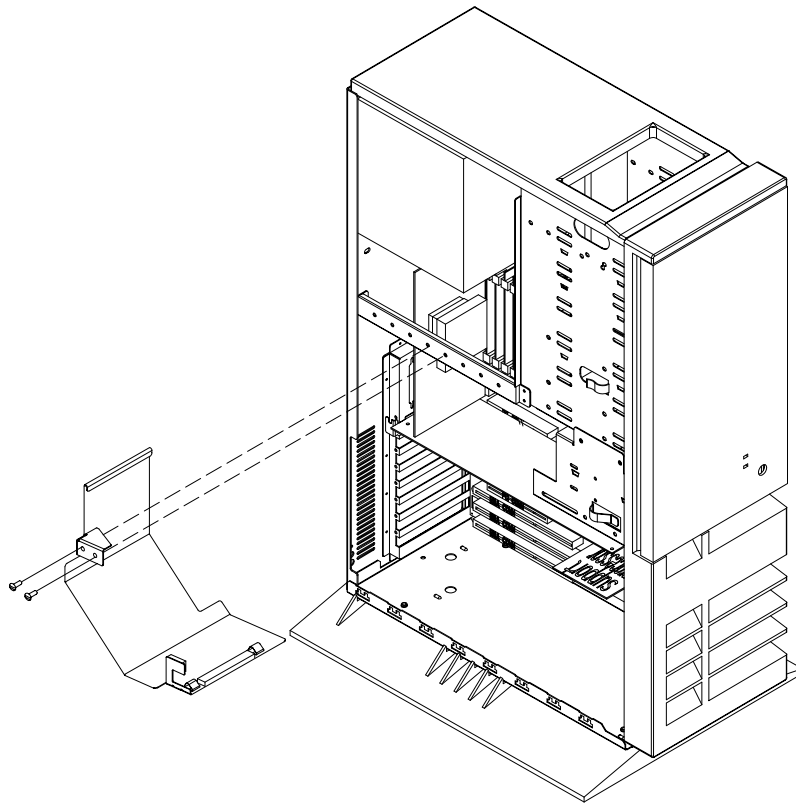

3. Locate the memory module connectors and determine which memory module you want to remove.

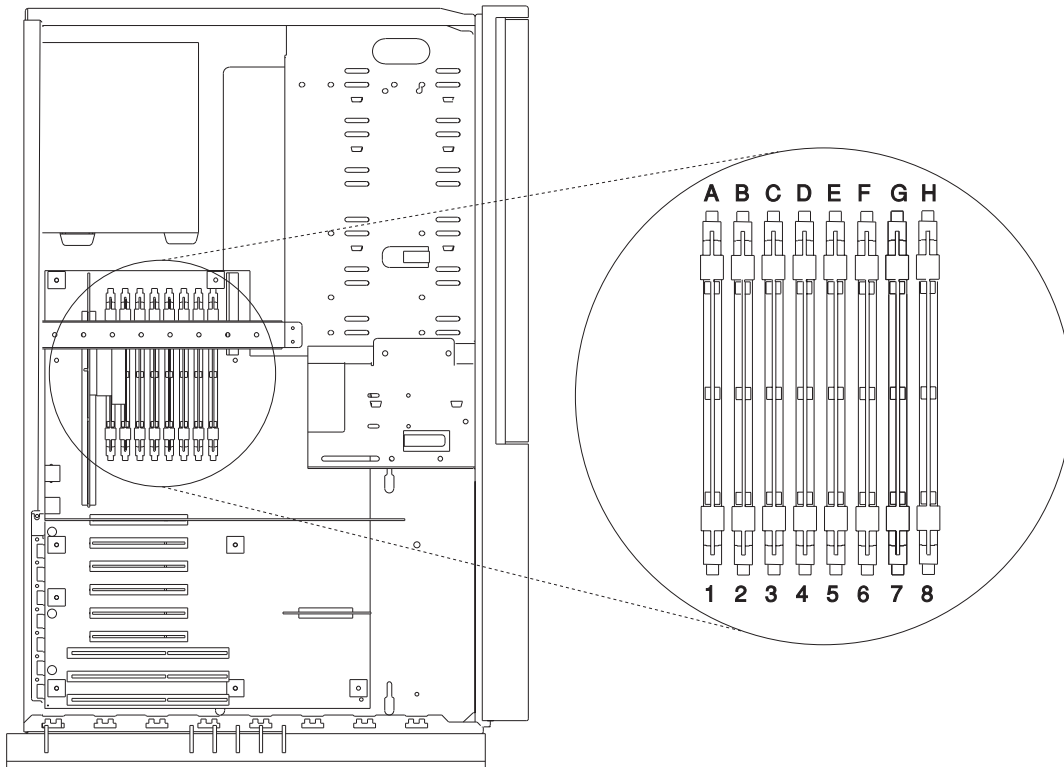

4. Remove the memory module:

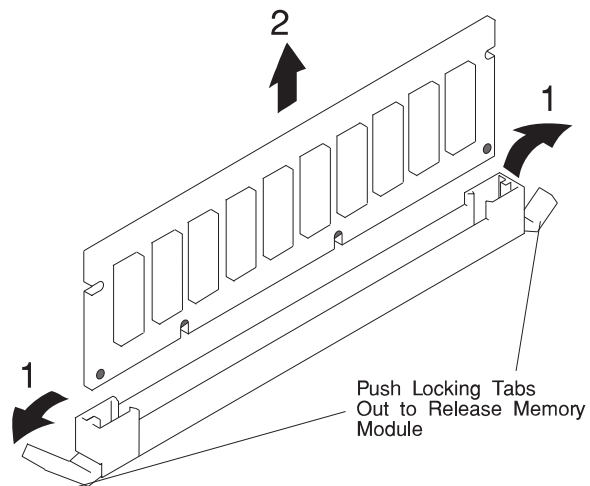

5. Store any memory modules you are no longer using in a static-protective package. Make a note of the kit size and speed for future reference.

Replacement

Attention: This system does not support channel memory, such as memory expansion adapters.

Note: New memory modules must be installed in the first available vacant connector, starting at A and progressing to H. The only exception is the 128MB memory module which cannot be installed in connector A due to space limitations.

1. The memory modules are keyed so that they can only be inserted one way. Align the memory module notches with the keys in the memory connectors.

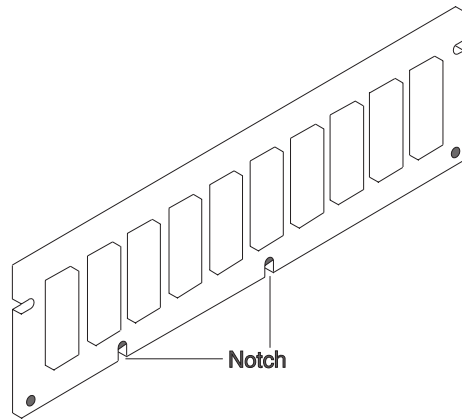

2. Insert the memory module into the next unused memory connector. Push down on the memory module until the latch tabs lock the memory module into the connector. (Do not attempt to move the latch tabs yourself. They lock automatically when you have fully inserted the memory module.)

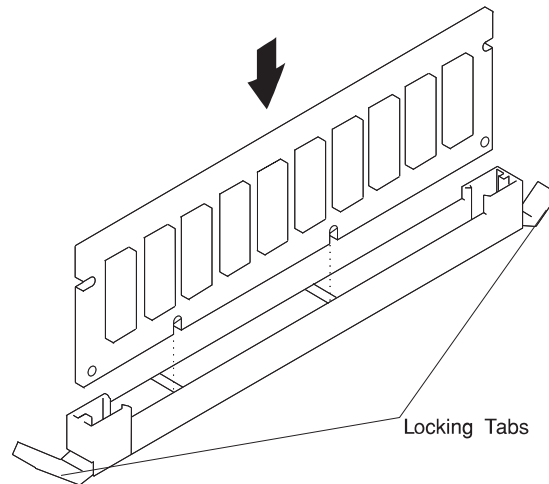

Attention: Inserting the memory module diagonally may damage the memory module.

3. If you have no more removal and replacement procedures to perform, replace the airflow baffle:
 - a. Insert the airflow baffle toward the front of the system unit.
 - b. Slide the airflow baffle toward the rear of the system unit, being careful not to disturb already-installed memory modules.
 - c. Insert and tighten the three screws that secure the airflow baffle to the system unit chassis.
4. Replace the system unit covers.

CPU Card

Removal

1. If you have not already done so, remove the covers as described in “Covers” on page 7-3.

Attention: Make sure you have unplugged the power cord and the standby power (Power LED) is Off before removing the CPU card.

2. Remove the two screws that secure the top and bottom CPU brackets to the system chassis, then remove the CPU brackets.
3. Remove the CPU card.

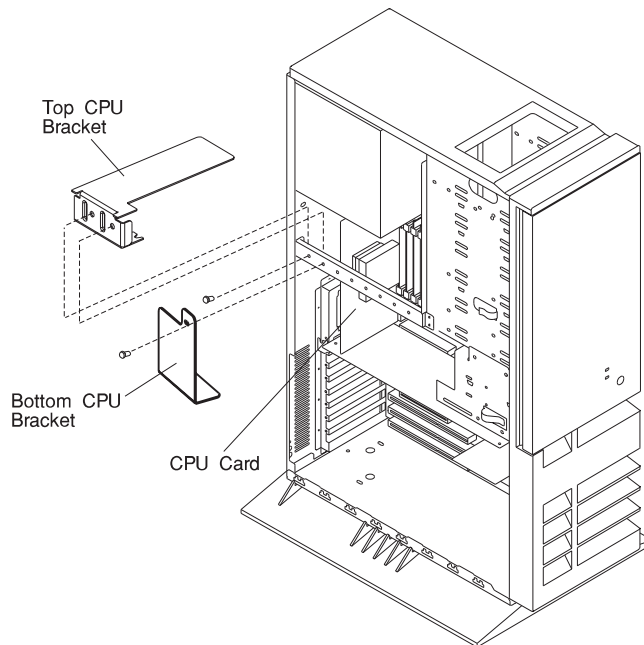

Replacement

To replace the CPU Card, perform the removal steps in the reverse order.

Service Processor

Removal

1. If you have not already done so, remove the covers as described in “Covers” on page 7-3.
2. Remove the screw that secures the retainer to the service processor bracket.

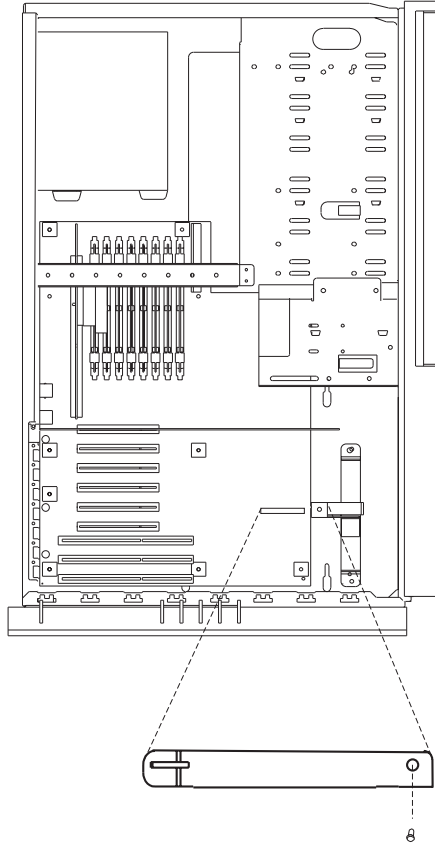

Attention: Make sure you have unplugged the power cord and the standby power (Power LED) is Off before removing the service processor.

3. Remove the service processor.

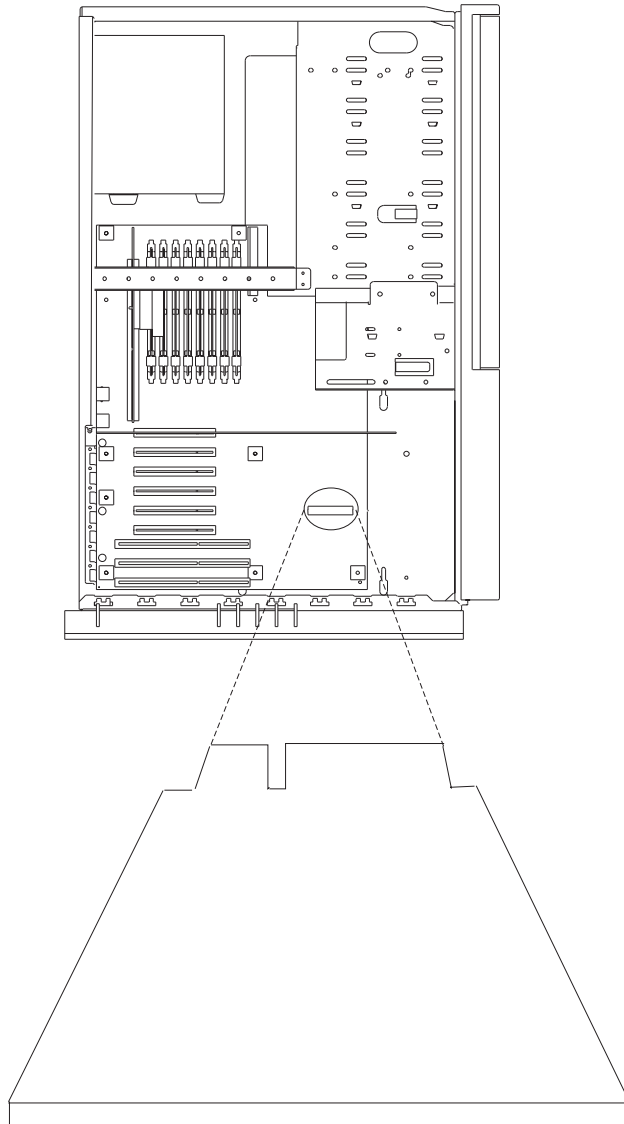

Replacement

To replace the service processor, perform the removal steps in the reverse order.

Battery

CAUTION:

A lithium battery can cause fire, explosion, or a severe burn. Do not recharge, disassemble, heat above 100°C (212°F), solder directly to the cell, incinerate, or expose cell contents to water. Keep away from children. Replace only with the part number specified for your system. Use of another battery may present a risk of fire or explosion.

Removal

1. If you have not already done so, remove the covers as described in “Covers” on page 7-3.
2. Locate the battery on the system board.

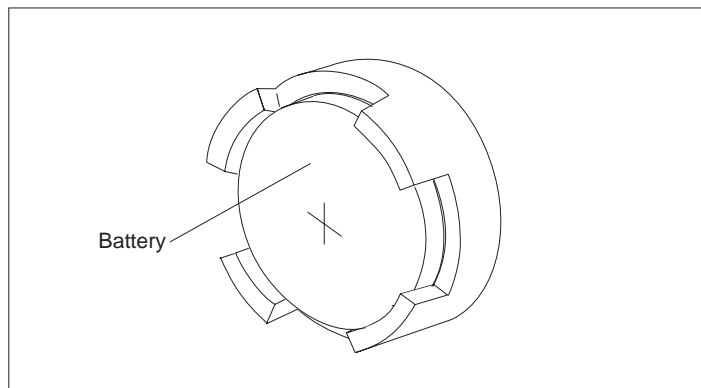

3. Use one finger to slightly slide the battery toward the front of the server. (The spring mechanism behind the battery pushes it out toward you as you slide it forward.) Use your thumb and index finger to hold the battery as it pushes out of the socket.

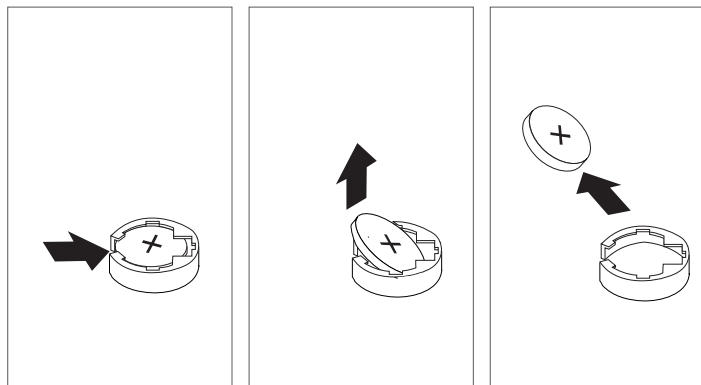

Replacement

Tilt the battery so that you can insert it into the front of the socket. As you slide the battery toward the front of the server, push it down into the socket.

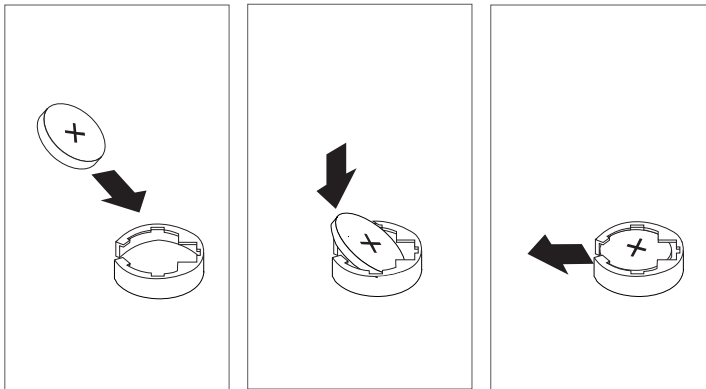

Notes:

1. Be sure to tell the customer that the time and date need to be reset.
2. Ensure that the battery polarity is correct; place the battery in the holder with the positive side facing up.

Fan and Speaker Assembly

Removal

1. If you have not already done so, remove the covers as described in “Covers” on page 7-3.
2. Remove the fan and speaker leads from the system planar.
3. Using a flat-head screwdriver, push upward on the lower set of plastic tabs that protrude through the front of the system unit chassis.
4. Swing the bottom of the speaker and fan assembly away from the front of the system unit, then remove the entire speaker and fan assembly.

Replacement

To replace the speaker and fan assembly, perform the removal steps in the reverse order.

Operator Panel Display

Removal

1. If you have not already done so, remove the front covers as described in "Covers" on page 7-3.
2. Remove the three screws that secure the airflow baffle to the system chassis, slide the airflow baffle to the front of the system unit, and remove the airflow baffle.

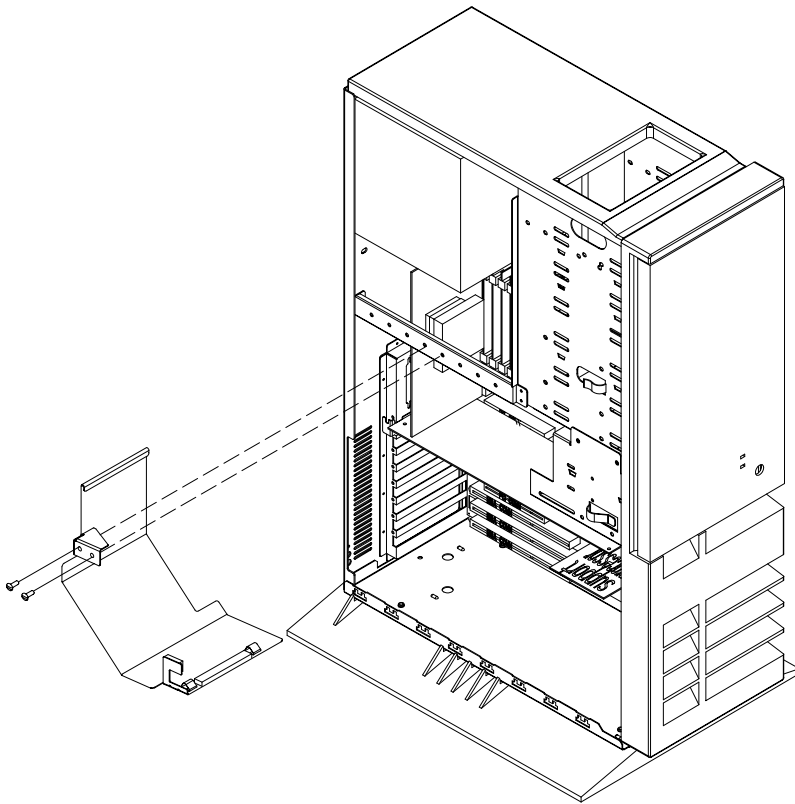

3. Remove the screws that secure the operator panel display assembly to the system chassis.

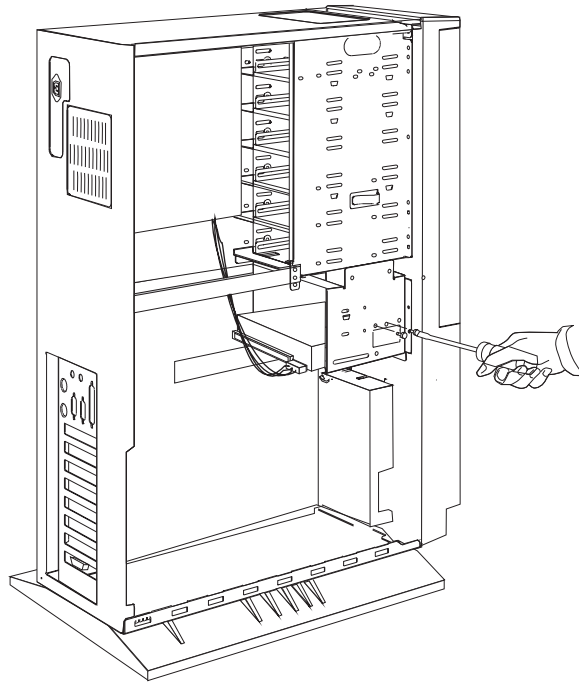

4. Open the door.
5. Pull the display panel from the front of the system unit and unplug the operator panel display cable from the rear of the operator panel display.

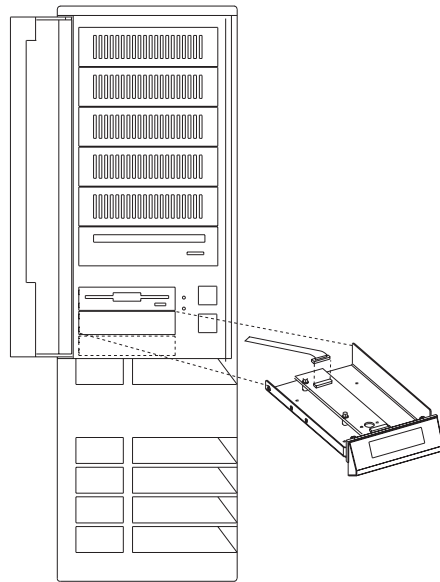

Replacement

Replace in reverse order.

System Board

Removal

1. If you have not already done so, remove the front covers as described in "Covers" on page 7-3.
2. Remove the three screws that secure the airflow baffle to the system chassis, slide the airflow baffle to the front of the system unit, and remove the airflow baffle.
3. Do the removal procedure in "Operator Panel Display" on page 7-28.
4. Do the removal procedure in "Adapters" on page 7-15.
5. Do the removal procedure in "Memory Modules" on page 7-17.
6. Do the removal procedure in "CPU Card" on page 7-22.
7. Unplug the operator panel display cable from the system planar.
8. Unplug the diskette drive cable from the system planar, and unplug the signal and power cables from the rear of the hard drive in bay 0.
9. Remove the two screws that secure the mounting cage for the diskette drive and hard drive in bay 0. Remove the mounting cage and set it aside.
10. Unplug the serial 1, serial 2, and parallel cables from the system board.
11. Unplug the power supply, speaker, and fan cables from the system board.
12. Unplug the power, SCSI, and hard drive LED cables from the system board.
13. Remove the screws that attach the system board to the system unit frame.
14. Slide the system board toward the front of the system unit, tip the bottom of the system board outward, and remove the system board.
15. Swap the old VPD module (U5) to the new system board.

Replacement

To replace the system board, do the removal steps in the reverse order.

Be sure to tell the customer that the time and date need to be reset.

Chapter 8. Parts Information

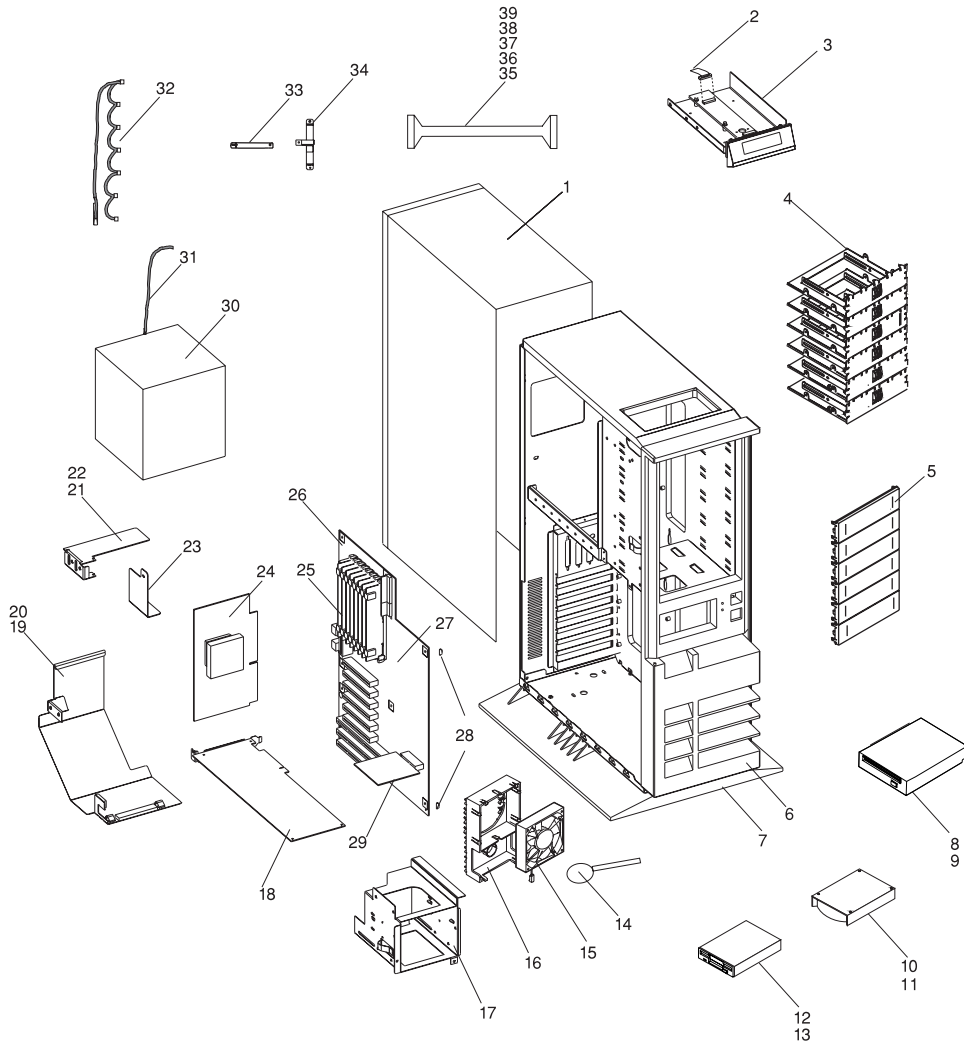

Index Number	Part Number	Units Per Assy	Description
1	40H6597	1	Chassis and cover
2	40H5434	1	LCD cable
3	40H2359	1	LCD assembly
4	06H2651	Up to 5	Media tray
5	06H2187	Up to 5	Media bezel
6	40H2344	1	Front bezel assembly (IBM)
	52G0208	1	Front bezel assembly (OEM)
7	06H9106	1	Pedestal
8	See note	1	CD-ROM
9	1621187	4	Screw
10	See note	1	Disk drive
11	1147429	4	Screw
12	See note	1	Diskette
13	1621187	4	Screw
14	06H2649	1	Speaker
15	06H2647	1	Fan
16	06H2645	1	Adapter card guide
17	06H4394	1	Diskette and disk drive cage
18	See Note	Up to 8	Adapter card
19	40H6596	1	Airflow baffle
20	06H2169	3	Screw (air baffle)
21	40H6672	1	Top CPU bracket
22	0322550	2	Screw (CPU card bracket)
23	73H3254	1	Bottom CPU bracket
24	40H6616	1	CPU card (Model E20, 100 Mhz)
	40H5381	1	CPU card (Model E30, 133 Mhz)
	12H1702	1	CPU card (Model E30, 166 Mhz)
25	065G4615	Up to 8	8MB memory module
	19H0288	Up to 8	16MB memory module
	065G4617	Up to 8	32MB memory module
	039H9837	Up to 8	64MB memory module
	073H3451	Up to 8	128MB memory module
26	40H6217	1	System planar
27	33F8354	1	Battery
28	06H7697	2	Standoffs
29	40H6675	1	Service processor
30	40H2115	1	Power supply
31	40H2120	1	Power supply cable (includes Start/Stop switch)
32	52G0170	1	Cable (7-drop)
33	73H3139	1	Service processor retainer
34	73H3138	1	Service processor bracket
35	11H8073	1	Diskette cable
36	40H2209	1	Cable (Parallel)
37	40H2210	1	Cable (S1-Serial)
38	40H2211	1	Cable (S2-Serial)
39	52G0172	1	Cable (SCSI 4-drop)

Note: See *IBM RS/6000 Diagnostic Information for Multiple Bus Systems* for part numbers.



Index Number	Part Number	Units Per Assy	Description
1	82G3278	1	Keyboard, United States English
	1391402	1	Keyboard, French
	1393395	1	Keyboard, Italian
	1391403	1	Keyboard, German/Austrian
	1391406	1	Keyboard, United Kingdom English
	1391405	1	Keyboard, Spanish
	79F0167	1	Keyboard, Japanese
	64F7707	1	Keyboard, Brazilian Portuguese
	82G3279	1	Keyboard, Canadian French
	1391526	1	Keyboard, Belgian French/Dutch
	1391411	1	Keyboard, Finnish
	1391407	1	Keyboard, Danish
	1399583	1	Keyboard, Bulgarian
	1395881	1	Keyboard, Swiss French
	1385882	2	Keyboard, Swiss German
	1391409	1	Keyboard, Norwegian
	1391511	1	Keyboard, Dutch
	1391410	1	Keyboard, Portuguese
	1399046	1	Keyboard, Greek
	1391408	1	Keyboard, Hebrew
	1399581	1	Keyboard, Hungarian
	1391407	1	Keyboard, Icelandic
	1399580	1	Keyboard, Polish
	1399582	1	Keyboard, Romanian
	1399571	1	Keyboard, Slovakian
	1399570	1	Keyboard, Czechoslovakian
	1393286	1	Keyboard, Turkish (ID 179)
	8125409	1	Keyboard, Turkish (ID 440)
	8131596	1	Keyboard, Arabic
	06H5286	1	Keyboard, Korean
	1393990	1	Keyboard, Chinese
	006H3048	1	Keyboard, United States (OEM)
2	11H4878	1	Mouse, 3-button

Power Cables

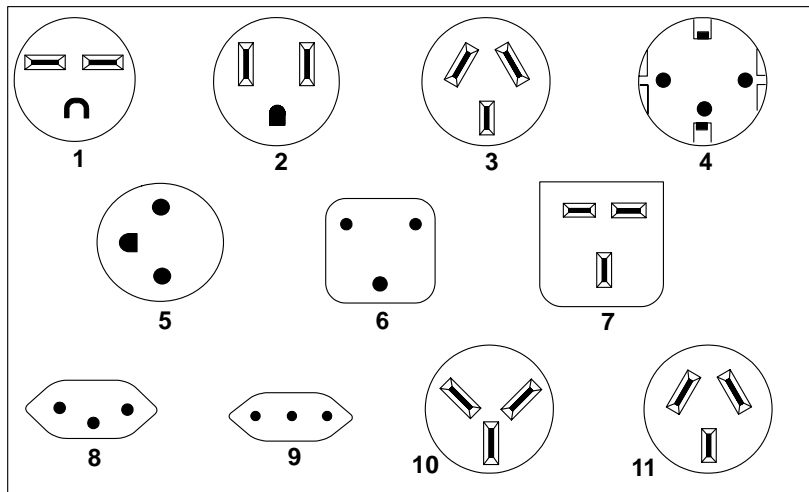

Index	Part Number	Country
1	1838574	Bahamas, Barbados, Bolivia, Brazil, Canada, Costa Rica, Dominican Republic, El Salvador, Ecuador, Guatemala, Guyana, Haiti, Honduras, Jamaica, Japan, Netherlands Antilles, Panama, Peru, Philippines, Taiwan, Thailand, Trinidad, Tobago, U.S.A. (except Chicago), Venezuela
2	6952300	Bahamas, Barbados, Bermuda, Bolivia, Brazil, Canada, Cayman Islands, Colombia, Costa Rica, Dominican Republic, Ecuador, El Salvador, Guatemala, Guyana, Haiti, Honduras, Jamaica, Japan, Korea (South), Mexico, Netherlands Antilles, Nicaragua, Panama, Peru, Philippines, Puerto Rico, Saudi Arabia, Suriname, Trinidad, Taiwan, U.S.A. (except Chicago), Venezuela
2	62X1045	Chicago, U.S.A.
3	6952311	Argentina, Australia, New Zealand
4	13F9979	Abu Dhabi, Austria, Belgium, Bulgaria, Botswana, Egypt, Finland, France, Germany, Greece, Iceland, Indonesia, Korea (South), Lebanon, Luxembourg, Macau, Netherlands, Norway, Portugal, Saudi Arabia, Spain, Sudan, Sweden, Turkey, Yugoslavia
5	13F9997	Denmark
6	14F0015	Bangladesh, Burma, Pakistan, South Africa, Sri Lanka
7	14F0033	Bahrain, Bermuda, Brunei, Channel Islands, Cyprus, Ghana, Hong Kong, India, Iraq, Ireland, Jordan, Kenya, Kuwait, Malawi, Malaysia, Nigeria, Oman, People's Republic of China, Qatar, Sierra Leone, Singapore, Tanzania, Uganda, United Arab Emirates (Dubai), United Kingdom, Zambia

Index	Part Number	Country
8	14F0051	Liechtenstein, Switzerland
9	14F0069	Chile, Ethiopia, Italy
10	14F0087	Israel
11	6952291	Paraguay, Colombia, Uruguay

Appendix A. Firmware Checkpoint Three-Digit Codes

These three digit codes will appear to the left of the top row on the Liquid Crystal Display(LCD) which is located on the front panel of the system. The intended use of the three digit codes is to assure the observer that the Firmware is operational after power on, and before information appears on the console display; there is no other diagnostic intent implied by the values of the three digit codes. If an Fxx code requires any action, it will be listed in Chapter 3, "Error Code to FRU Index" on page 3-1.

Checkpoint (hex)	Description
F00	Manufacturing - Reserved for Parallel port download protocol
F01	Clear the EPOW register
F02	Determine system bus speed, set ISA divisor
F04	Set memory refresh
F06	Jump to set environment or check flash
F08	Run recovery block base memory, test 2k, then set stack
F09	Copy CRC verification code to RAM
F0A	Turn on cache
F0B	Flush cache
F0C	Jump to CRC verification code in RAM
F0D	Compute composite image CRC
F0E	Jump back to ROM
F0F	Turn off cache
F10	Check if composite image CRC is valid
F11	GOOD CRC - jump to composite image
F12	BAD CRC - initialize base memory, stack
F13	BAD CRC - copy uncompressed recovery block code to RAM
F14	BAD CRC - jump to code in RAM
F15	BAD CRC - turn on cache
F16	BAD CRC - copy recovery block data section to RAM
F17	BAD CRC - Invalidate and flush cache, set TOC
F18	BAD CRC - branch to high level recovery control routine
F19	Initialize base memory, stack
F1A	Copy uncompressed recovery block code to RAM
F1B	Jump to code in RAM
F1C	Turn on cache
F1D	Copy recovery block data section to RAM
F1E	Invalidate and flush cache, set TOC
F1F	Branch to high level control routine
F20	Initialize System I/O
F21	Run a console diagnostic routine
F22	No memory found
F23	No DIMM found in the socket
F24	Remove bad DIMM found from DIMM information
F25	Unsupported DIMM detected
F26	Check valid image - start
F27	Check valid image - successful
F28	Wait for interrupt

Checkpoint Description (hex)	
F29	Transfers information to the business audio chip
F2B	Wait till sound chip has been initialized
F2C	Initialize the current input/pointer device
F2D	Initialize the current output
F2E	Register a console driver
F30	Set up early memory allocation heap, Initialize Super I/O
F31	Determine system bus speed, set ISA divisor
F32	Resync to SP (Composite Image)
F33	Set memory refresh
F35	Jump to set environment
F40	Initialize interrupt subsystem and 8259s
F41	SP command setup
F42	SP Mailbox interface
F43	get_vpd entry
F44	init_sp entry
F45	sp_recovery -> resync SP & CPU
F46	IRQ13 stuck high
F47	Entry to error checking routine
F48	Power Supply or System Board problem
F49	Voltage problem. System Board, Power Supply or CPU
F4A	Voltage problem. System Board or Power Supply
F4B	CPU over temperature or bad System Board
F4C	Start bit-map display function
F4D	Bit-map file read into memory, start processing
F4E	End bit-map display function
F4F	IO/MEM over temperature or bad System Board
F50	Initialize CMOS RTC periodic interrupt
F51	System Board or System over temperature
F52	Bad System Board (Fan Fail reported)
F53	Bad System Board
F54	Fan fail warning
F55	Bad System Board (Unsupported EPOW)
F56	Voltage problem. System Board, Power Supply or CPU
F57	Bad or low battery
F58	IRQ13 test failure
F59	EPOW test failure
F5A	Spurious IRQ 7 interrupt (ie: interrupt glitch)
F5B	Fan failure warning
F5C	Clear EPOW register failure
F5D	Clear EPOW register failure
F60	Initialize keyboard/mouse controller, and password
F61	Extended memory initialization command
F62	Diskette initialization command
F64	Test of day routine
F6A	SCSI Initialization command
F70	Initialize debugger
F71	Start Checking whether CMOS contents are valid
F72	End Checking whether CMOS contents are valid
F73	Dumps contents of CMOS data area to a file
F74	CMOS Initialization
F75	Loads contents of CMOS from file

Checkpoint (hex)	Description
F77	Resync to SP (Recovery Image)
F79	Dumps contents of NVRAM data area to a file
F7A	NVRAM Initialization
F7B	Check NVRAM validity CRC
F7C	Loads contents of CMOS from file
F80	Initialize system call table
F82	Register a manager for use by the system
F88	Halt. System locked by error condition -- power off.
F90	Initialize VDISK file system
F91	Low-level initialize VDISK file systems
F94	Start SCSI initialization
F96	SCSI bus scan start
F97	SCSI polling interrupt
F98	SCSI device detected
F9F	Exit SCSI initialization
FA0	Start resident monitor, run V:autoexec.6md - initializes various subsystems - video, keyboard/mouse, extended memory, diskette, SCSI, etc.
FA1	Enter resident monitor
FA2	Resident monitor process
FA3	Resident monitor process
FA4	Exit resident monitor
FA5	ASCII terminal initialization
FA6	ASCII terminal initialization exit
FA9	p9 driver initialization
FAA	p9 driver exit
FAB	Keyboard driver initialization
FAC	Keyboard driver exit
FAD	Mouse driver initialization
FAE	Mouse driver exit
FB0	Initialize rest of file system
FB1	Diskette initialization
FB2	Diskette drive type determination
FB3	Diskette initialization complete
FC0	Check if flash ROM OK
FCA	Build boot table - Networks
FCB	Build boot table - DASD
FCC	Build boot table - CD ROM
FCD	Build boot table - diskettes
FCE	No Operating System boot, exit normal boot sequence
FD0	Start of boot sequence
FD2	No Operating System boot - ensure CMOS RTC periodic clock updates displayed
FD4	Initialize console for loading diagnostics
FD8	Exit from diagnostic - run resident monitor
FDA	IRQ 15
FDB	Unexpected processor exception
FDC	Unexpected external interrupt exception
FDD	Early processor exception
FDE	Shutdown entire file system
FE1	Test Timeout
FE2	Initialize System I/O
FE4	Initialize Super I/O with default values

Checkpoint Description (hex)	
FE6	Set up early memory allocation heap
FE8	Initialize primary diskette drive in polled mode
FEA	Try to load in recovery image from diskette
FEB	Verify recovery image is valid
FEC	Get recovery image entry point
FED	Invalidate instruction cache
FEE	Jump to composite image
FF0	Manufacturing - Check for Parallel Port hook
FF4	Manufacturing - Start flag not received
FF5	Manufacturing - Invalid Start flag received
FF6	Manufacturing - Receive character timeout
FF7	Manufacturing - CRC value mismatch
FFA	Error during flash update
FFC	Operating System boot - No errors reported by IPL ROS
FFD	Operating System boot - Non-critical errors reported by IPL ROS
FFE	No boot - Critical error(s) reported by IPL ROS or "F1" key pressed

Index

A

- about this book xix
- adapters
 - removal and replacement 7-15
- ASCII Terminal System Management Services programs 5-16
 - Select Boot Devices program 5-17
 - Test the Computer program 5-18
 - Utilities program 5-19

B

- battery
 - removal and replacement 7-25
- boot list 4-2

C

- cables
 - power 1-10
- covers
 - removal and replacement 7-3
- CPU card
 - removal and replacement 7-22

D

- devices, startup 5-4
- diagnostics, online 4-1
- diagnostics, standalone 4-1
- diskette drive and lower hard disk drive
 - removal and replacement 7-12

E

- Enable Unattended Start Mode program 5-14, 5-19

- error code to FRU index 3-1
- error codes
 - POST 3-1

F

- fan and speaker assembly
 - removal and replacement 7-27
- firmware 6-1
- firmware beeps 6-4
- firmware flash update 6-7
- function keys 6-5

G

- graphical System Management Services 5-2
 - Start Up program 5-4
 - Test program 5-5
 - Tools program 5-7

H

- handling static-sensitive devices 7-2

I

- index, error code to FRU 3-1

L

- laser safety information xvii
- loading the system diagnostics 4-1
- locations
 - system unit 1-1
 - system board 1-5

M

maintenance analysis procedures
(MAPs) 2-1
 minimum configuration Map 2-18
 power MAP 2-12
 problem determination MAP 2-7
 quick entry MAP 2-2
media drive in bays 4 through 8
 removal and replacement 7-9
memory modules
 removal and replacement 7-17
minimum configuration Map 2-18

O

online diagnostics 4-1
operator panel display
 removal and replacement 7-28

P

parts information 8-1
password design 6-6
POST (power on self test) 6-9
POST error codes 3-1
POST error status codes 3-16
POST indicators 6-11
power cables 1-10
power MAP 2-12
power on self test (POST) 6-9
power supply
 removal and replacement 7-7
power switch and indicator LEDs 1-8
power-on password 5-14, 5-19
preface xix
privileged-access password 5-14, 5-19
problem determination MAP 2-7
programs, ASCII Terminal System
 Management Services 5-16

Q

quick entry MAP 2-2

R

related publications xix
removal and replacement
 adapters 7-15
 battery 7-25
 covers 7-3
 CPU card 7-22
 diskette drive and lower hard disk
 drive 7-12
 fan and speaker assembly 7-27
 media drive in bays 4 through 8 7-9
 memory modules 7-17
 operator panel display 7-28
 power supply 7-7
 service processor 7-23
 system board 7-31
RIPL (remote initial program
 load) 5-14, 5-19

S

select boot devices
 Text-Based System Management
 Services programs 5-12
Select Boot Devices program
 ASCII Terminal System Management
 Services programs 5-17
sequence, startup 5-4
service inspection guide 1-11
service processor 7-23
 removal and replacement 7-23
Set Power-On Password 5-14, 5-19
Set privileged-access password 5-14,
 5-19
specifications 1-7

- speed, memory 7-20
- standalone diagnostics 4-1
- start mode 5-14, 5-19
- Start Up program
 - graphical System Management Services 5-4
- starting system programs 5-1
- system board
 - removal and replacement 7-31
- system board locations 1-5
- System Management Services 5-1
- System Management Services, ASCII terminal 5-16
- System Management Services, text-based 5-11
- System Management Services, graphical 5-2
- system programs 5-1
 - starting 5-1
- system unit locations 1-1

T

- Test program
 - graphical System Management Services 5-5
- Test the computer
 - Text-Based System Management Services programs 5-13
- Test the Computer program
 - ASCII Terminal System Management Services programs 5-18
- Text-Based System Management Services programs 5-11
 - select boot devices 5-12
 - Test the computer 5-13
 - utilities 5-14
- Tools program
 - graphical System Management Services 5-7

U

- unattended start mode 5-14, 5-19
- updating service processor firmware 5-15, 5-20
- updating system firmware 5-20
- utilities
 - Text-Based System Management Services programs 5-14
- Utilities program
 - ASCII Terminal System Management Services programs 5-19

V

- virtual disk 6-2



Part Number: 93H4991



Printed in the United States of America
on recycled paper containing 10%
recovered post-consumer fiber.

April 1997

SA38-0502-03



93H4991

