







## Listing of Current Intervention Devices

Company Contact Information	Illustration of Product	Description of Product
<p><b>SAFE MARINE LTD</b>                      P.O. Box 100954                      N.S.M.C                      Auckland, New Zealand                      Mobile: 0274 866-850  <a href="mailto:safemarine@xtra.co.nz">safemarine@xtra.co.nz</a>  <a href="http://www.propguard.co.nz/index.html">http://www.propguard.co.nz/index.html</a></p>	 <p style="text-align: center;"><b>PropGuard</b></p>	<p><b>Propeller Guard System:</b></p> <p><b>PropGuard</b> uses the Kort Nozzle system helps to make this happen. A Kort Nozzle is specifically designed around this principle. Taking into consideration Bernoulli's continuity equation for incompressible flow between cross sectional areas.</p> <p>Developed to assist in the:</p> <ul style="list-style-type: none"> <li>Protection of swimmers and divers in the water</li> <li>Prevention of rope entanglement</li> <li>Protect propeller when used in and around rocks and other underwater hazards</li> <li>Allowing for safe operation in shallow water</li> <li>Give protection to family and friends against serious injury when using an outboard motor</li> </ul> <p><b>PropGuard</b> is supplied with attaching screws, allen key and simple instructions for easy installation.</p> <p>For Outboards from 2-40 HP (see Attachment A)</p> <p>Price: <b>\$195</b></p>
<p><b>Propeller Safety Guard</b>                      Phone: 604-533-0990                      Fax: 604-533-0611                      Email: <a href="mailto:info@allinflatables.com">info@allinflatables.com</a>  <a href="http://www.allinflatables.com/shopping/custom/guards.html">www.allinflatables.com/shopping/custom/guards.html</a></p>	 <p style="text-align: center;"><b>Propeller Safety Guard</b></p>	<p><b>Propeller Guard System:</b></p> <p>The propeller safety guard is an ideal accessory for rescue boats, life boats, water ski boats, dive boats, rental boats, houseboats, children &amp; swimmers in water around boats, etc. The entire guard and fasteners are electro-polished stainless steel. Mounting hardware included. Model 9000 Safety Guards:</p> <ul style="list-style-type: none"> <li>For 8 HP - Max Speed 30 mph:</li> <li>For 120 HP - Max Speed 40 mph:</li> <li>For 200 HP - Max Speed 30 mph:</li> </ul> <p>Price: <b>\$279 to \$375</b> (see Attachment B)</p>

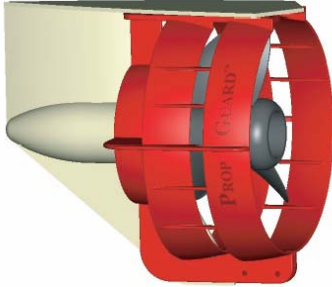

## Listing of Current Intervention Devices

Company Contact Information	Illustration of Product	Description of Product
<p><b>PROP GUARD MARINE, INC.</b>            P.O. BOX 630            WESTCLIFFE, CO 81252            Phone: (719) 783-2639            Fax (719) 783-0230            Email: <a href="mailto:info@propguardmarine.com">info@propguardmarine.com</a>  <a href="http://www.propguardmarine.com/index.html">www.propguardmarine.com/index.html</a></p>	<div style="text-align: center;">  <p><b>PROP GUARD®</b></p> </div>	<p><b>Propeller Guard System:</b></p> <p>Prop Guards will fit all Manufacturers Outboards and Stern Drives. Note: All hp's with Big Foot &amp; High Thrust applications require next size up.</p> <p>ALL APPLICATIONS of the 13", 14", and 16" Prop Guards are for PONTOON AND DECK BOATS, and any other application that the <b>vessel does not exceed 25 mph</b> (until our new design comes out).</p> <p>To obtain optimal performance out of your motor with the Prop Guard® installed, you may need to change your propeller diameter.</p> <p>Claim they have solved the High speed issues and are currently tooling for a new design which should be available soon</p> <p>Price: from <b>\$116.95</b> to <b>\$175.95</b> (see Attachment C)</p>
<p>MariTech Industries            6680 Lockheed Dr.            Redding, CA 96002-9003            Phone: 530-226-7414            Email: <a href="mailto:info@maritechsafety.com">info@maritechsafety.com</a>  <a href="http://www.maritechsafety.com/main.php?p=home">http://www.maritechsafety.com/main.php?p=home</a></p>	<div style="text-align: center;">  <p><b>SwimGuard Pro</b></p>   <p><b>SwimGuard</b></p> </div>	<p><b>Propeller Guard System:</b></p> <p>SwimGuard - Designed to maximize human protection from propeller related accidents. 360-degree encasement of the propeller provides the surest form of protection available. Installation is quick, easy, and no drilling is required. Each SwimGuard is custom made out of durable stainless steel according to your specifications and powder coated for added life.</p> <p>Customized for a perfect fit from the smallest (9.9 hp) to the largest motors -- single and dual propellers.</p> <p>High grade stainless steel construction</p> <p><b>No drilling or mounting holes required</b></p> <p>Ease of installation</p> <p>One year manufacturer's warranty</p> <p>Price: <b>\$399</b> Both SwimGuard and SwimGuard Pro            (see Attachment D)</p>

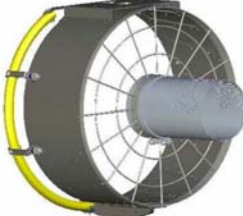

## Listing of Current Intervention Devices

Company Contact Information	Illustration of Product	Description of Product
<p><b>PropBuddy™</b>            Propeller Guard and Thruster            Phone: 321- 636-8509            Email to <a href="mailto:MoreInfo@PropBuddy.com">MoreInfo@PropBuddy.com</a>  <a href="http://www.propbuddy.com">http://www.propbuddy.com</a></p>	 <p style="text-align: center;"><b>PROP BUDDY® &amp; THRUSTER™</b></p>	<p><b>Propeller Guard System:</b></p> <p>The PROP BUDDY® propeller guard is a device that fits over the open-blade propeller on a boat, and is made of 304 stainless steel.</p> <p>Price: <b>\$1,100 to \$1,200</b> (made to order)</p>
<p>EnviroProp Corporation            8466 N.Lockwood Ridge Road            Suite 261            Sarasota, FL 34243            Phone: 888- 788-5516            Email: <a href="mailto:enviroprop@aol.com">enviroprop@aol.com</a>  <a href="http://www.enviroprop.com">www.enviroprop.com</a></p> <p style="text-align: center;">Patents Pending</p>	 <p style="text-align: center;"><b>UNIVERSAL GUARD WITH BUMPERGUARD</b></p>	<p><b>Propeller Guard System:</b></p> <p>EnviroProp™ with Turbo Thrust &amp; Anti-Theft is aerodynamically engineered to increase the maneuverability of a boat through the performance of EnviroProp™ by increasing the number of lbs of thrust without increasing a fixed RPM, utilizing the existing propeller. Greater propeller thrust at any fixed RPM should also result in substantial fuel savings.</p> <p>Utilize light weight high impact materials including 60 series aluminum, or state-of-the-art polypropylene in a multiple choice of colors, or stainless steel.</p> <p>Available for immediate delivery for most propeller driven power trains, sizes (10" to 20.5" DIA.) fitting most Outboards and Sterndrives/I/O's. Custom order available for all other types/sizes of propeller driven marine craft.</p> <p>Price: <b>\$400</b></p>
<p>EnviroProp Corporation            8466 N.Lockwood Ridge Road            Suite 261            Sarasota, FL 34243            Phone: 888- 788-5516            Email: <a href="mailto:enviroprop@aol.com">enviroprop@aol.com</a></p> <p style="text-align: center;">Patents Pending</p>	 <p style="text-align: center;"><b>Supro Guard with CO Dispenser</b></p>	<p><b>Propeller Guard System:</b></p> <p>The Supro Guard with CO-Dispenser, protecting against the ever present danger of Carbon Monoxide (CO) exhaust thru the propeller hub. (Dispersing the CO exhaust into approximately 2000 opulets). Fabricated from light weight high impact materials.</p> <p>Price: <b>\$200 to \$300</b>            New CO-Dispenser: <b>\$50</b></p>



## Listing of Current Intervention Devices

Company Contact Information	Illustration of Product	Description of Product
<p>EnviroProp Corporation            8466 N.Lockwood Ridge Road            Suite 261            Sarasota, FL 34243            Phone: 888- 788-5516            Email: <a href="mailto:enviroprop@aol.com">enviroprop@aol.com</a></p> <p style="text-align: center;">Patents Pending</p>	<div style="text-align: center;">  </div> <p style="text-align: center;"><b>Trolling Motor Guard with Impeller</b></p>	<p><b>Propeller Guard System:</b></p> <p>Up to 50% increased performance, draws 6 to 8 less volts, no bubbles, totally silent. High Impact Nylon Poly, Guard and 9 Blade Impeller.</p> <p>Note, this device not shown on their Website.</p> <p>Price: <b>\$125</b></p>
<p>Superior Marine Systems            Phone: 520-266-0520            Email: <a href="mailto:smsthruster@yahoo.com">smsthruster@yahoo.com</a></p> <p style="text-align: center;">Patent Pending "Tandem Propeller Nozzle for Water Craft"</p>	<div style="text-align: center;">  </div> <p style="text-align: center;"><b>THRUSTOR™</b></p>	<p><b>Propeller Guard System:</b></p> <p>THRUSTOR™ is a Tandem Propeller Nozzle, Thrust-Guard System for Watercraft.</p> <p>Manufacturer's Claim: "ABSOLUTELY and totally enhances the performance of all outboard and stern drive vessels. It is suitable for application to all OB and SD watercraft. The unique fitting method creates the capability to adapt the propeller protection system to fit all motor types and sizes."</p> <p>Production models are in process, via Soft Tooling (RTV molding).</p> <p>Sizes: (In order of production demand) 14.5", 16.5", 12.5" (Greater Europe), 15.5" (stern drives &amp; 150-250 hp), 13.5"; these will be followed by 4-5 additional sizes.</p> <p>Price: Unknown</p>



## Listing of Current Intervention Devices

Company Contact Information	Illustration of Product	Description of Product
<p><b>RingProp PLC</b>                      Haslar Marine Technology Park                      Gosport, Hants P012 2AG                      England                      Phone: +44 239 233 5788                      Fax: +44 239 233 5787                      Email: <a href="mailto:Info@ringprop.com">Info@ringprop.com</a>  <a href="http://www.ringprop.com">http://www.ringprop.com</a></p> <p>Patented Torc-Loc® universal hub system</p> <p>Claims a range of patented ringed propellers, but no patent references provided at Website.</p>	 <p style="text-align: center;"><b>RingProp™</b></p>	<p><b>Propeller Ring System:</b></p> <p>RingProp's patented Torc-Loc® universal hub system is provided with the propeller and allows one prop to fit a number of engine brands. It also allows the hub to be fitted at home without the need for specialized equipment. The patented ring design provides structural support to the propeller blades and provides them some protection from striking underwater objects, since the blade tips are not exposed. The propellers are manufactured from corrosion resistant alloy by RingProp's manufacturing partner - one of the world's leading die casting companies. RingProps have a two stage, high gloss powder coat finish.</p> <p>Dealers Discount Prices: (see Attachment E)</p> <p style="padding-left: 40px;"><b>\$196</b> - 20hp through to 60 hp aluminium  <b>\$240</b> - Over 60 hp to 115 hp aluminium  <b>\$399</b> - 135 hp plus Stainless steel</p>
<p>Typical MerCruiser Remote Control</p>	 <p style="text-align: center;"><b>Commander 3000 Classic Panel Mount</b></p>	<p><b>Lanyard Kill Switch</b></p> <p>Lanyard Stop Switch (if equipped) turns ignition "Off" whenever the operator (when attached to the lanyard) moves far enough away from the operator's position to activate the switch.</p> <p>Currently installed on all new power boats.</p>



## Listing of Current Intervention Devices

Company Contact Information	Illustration of Product	Description of Product
<p>MariTech Industries            6680 Lockheed Dr.            Redding, CA 96002-9003            Phone: 530-226-7414            Email: <a href="mailto:info@maritechsafety.com">info@maritechsafety.com</a>  <a href="http://www.maritechsafety.com/main.php?p=home">http://www.maritechsafety.com/main.php?p=home</a></p> <p style="text-align: center;">Patent Pending</p>	<div style="text-align: center;">  <p><b>CAST - Wireless Lanyard</b></p> </div>	<p><b>Wireless Lanyard Kill Switch:</b></p> <p>CAST - Wireless Lanyard - This wireless solution eliminates hitch and un-hitch time, accidental disconnects, and annoying entanglements commonly found with lanyards kill switch. Marketed for tournament and competition fishing. Includes: System Control Module, 2 Transmitters, Installation Instructions, and Owner's Manual.</p> <p>Price: <b>\$469</b> (see Attachment F)            Additional transmitter priced <b>\$69</b> each</p>
<p>MariTech Industries            6680 Lockheed Dr.            Redding, CA 96002-9003            Phone: 530-226-7414            Email: <a href="mailto:info@maritechsafety.com">info@maritechsafety.com</a>  <a href="http://www.maritechsafety.com/main.php?p=home">http://www.maritechsafety.com/main.php?p=home</a></p> <p style="text-align: center;">Patent Pending</p>	<div style="text-align: center;">  <p><b>Virtual Lifeline</b></p> </div>	<p><b>Wireless Lanyard Kill Switch:</b></p> <p>Virtual Lifeline is designed to reduce injuries and damage associated with falls overboard ... the #1 cause of injury in recreational boating. Each unit consists of four sensors (about the size of a watch) and an ignition control module that is easily installed, usually in an hour or less. The sensors can be worn in a variety of ways, such as attached to a PFD or swim suit, to a belt loop, etc. and is activated when anyone is ejected into the water. Once submerged, the sensor transmits a signal to the control module, which sounds an alarm and immediately shuts off the motor -- stopping the propeller. The unit can quickly be put into rescue mode for retrieval of the overboard passenger. Solo boaters will feel confident by knowing that the unit reduces risks due to a boat running without a skipper.</p> <p>Price: <b>\$549</b> (see Attachment F)            Additional sensors priced <b>\$59</b> each</p>

# Listing of Current Intervention Devices

Company Contact Information	Illustration of Product	Description of Product
<p>MOBi-lert  P.O. Box 1533 APPLECROSS  Western Australia 6953  Phone: +61 08 9315 3511  <a href="mailto:gabyh@mobilert.com">gabyh@mobilert.com</a>  <a href="http://www.mobilert.com/default.asp?id=home">http://www.mobilert.com/default.asp?id=home</a></p> <p style="text-align: center;">(Sold in USA at West Marine)</p>	<div style="text-align: center;">  <p><b>CrewSafe 7000 Series</b></p>  <p><b>CrewSafe 7200      CrewSafe 7600</b></p> </div>	<p><b>Wireless Lanyard Kill Switch:</b></p> <p>The CrewSafe 7000 series is designed to enable a quick rescue in a man overboard emergency. The heart of the system is a rechargeable and waterproof Personal Transmitter (PTX) worn by every person on board. Each PTX maintains a constant link with a central <a href="#">Console</a> unit on your boat. The instant one of your crew is in the water, an automatic alarm is sounded and the vessel's position is logged. The MOBi-lert Console will immediately provide a graphic Track-Back Screen to guide even the most inexperienced helmsperson back to the exact point where your crew member was lost. Supports a second switched relay output which can be used for the following:</p> <ul style="list-style-type: none"> <li>• Second alarm (audible or visual);</li> <li>• <b>Engine cut-out/self-steering disable</b>; or</li> <li>• EPIRB or Dan Buoy release</li> </ul> <p>Price: <b>\$1,499.99</b> Model 7200 (two PTX)  <b>\$2,499.99</b> Model 7600 (six PTX &amp; own GPS.)</p>
<p>MariTech Industries  6680 Lockheed Dr.  Redding, CA 96002-9003  Phone: 530-226-7414  Email: <a href="mailto:info@maritechsafety.com">info@maritechsafety.com</a>  <a href="http://www.maritechsafety.com/main.php?p=home">http://www.maritechsafety.com/main.php?p=home</a></p> <p style="text-align: center;"><u>U.S. Patent No. 6,276,974 "Switch system for preventing marine propeller injuries"</u></p>	<div style="text-align: center;">  <p><b>The Prop Stopper</b></p> </div>	<p><b>Engine Stop/Prevent Start System:</b></p> <p><b>The Prop Stopper</b> protects swimmers by preventing the motor from starting while the ladder is down where swimmers are closest to the boat's propeller and exhaust. Also can be installed on swimmer access doors.</p> <ul style="list-style-type: none"> <li>Operates on all 12V DC systems</li> <li>Ease of installation</li> <li>May be used for multiple ladders and locations</li> <li>ABYC compliant</li> <li>One year manufacturer's warranty</li> </ul> <p>Priced: <b>\$129</b> (see Attachment G)</p>

# Listing of Current Intervention Devices

Company Contact Information	Illustration of Product	Description of Product
<p>IntelliJet Marine, Inc.            4805 158th Court NE            Redmond, WA 98052-5261            Phone: 425-869-2723            Email: <a href="mailto:info@intelliJetMarine.com">info@intelliJetMarine.com</a>  <a href="http://marinejettech.com/index.html">http://marinejettech.com/index.html</a></p> <p>U.S. Patent No. 5,658,176 "Marine Jet Propulsion System"            U.S. Patent No. 5,679,035 "Marine Jet Propulsion Nozzle and Method"            U.S. Patent No. 5,683,276 "Marine Jet Propulsion Inlet Duct and Method"</p>	 <p style="text-align: center;"><b>IntelliJET The 2nd Generation</b></p>	<p><b>Water Jet Propulsion System:</b></p> <p>Based on hydraulic lab data and simulation, it will offer better acceleration than a propeller with the same top speed, better fuel efficiency, better maneuverability (including ease of control), shallow water operation, and no problem with submerged logs, in addition to the much improved safety and environmental aspects.</p> <p>Price: Unknown</p> <p>They have not established pricing for their initial product, but expect to be cost competitive with propeller based systems in large-scale production.</p>
<p>ACT, Inc.            Marine Propulsion Division            6831 Edgewater Commerce Parkway            Orlando, FL 32810            Phone: 877-786-7538            Email: <a href="mailto:pumpjet2@bellsouth.net">pumpjet2@bellsouth.net</a>  <a href="http://www.actorlando.com/default.htm">www.actorlando.com/default.htm</a></p> <p>Also know under following Trade Names:  <b>Dura Jet</b> – Recreational Market  <b>Enforcer</b>- Military Market  <b>Rescue Pro</b> – Search &amp; Rescue Market</p> <p>U.S. Patent No. 5,273,467 Exhaust discharge for a pump jet            U.S. Patent No. 5,325,662 Advanced exhaust discharge for pump jet propulsion apparatus            U.S. Patent No. 6,887,117 Pump jet with an exhaust bypass and associated methods</p>	 <p style="text-align: center;"><b>1st Generation</b></p>  <p style="text-align: center;"><b>2nd Generation The Pump Jet</b></p>	<p><b>Water Jet Propulsion System:</b></p> <p>The Pump Jet is an advanced design propulsion system. The innovative design replaces the conventional propulsion system, the open propeller. The Pump Jet is NOT a propeller guard or a shallow water pumping system. The forward-looking orientation of the Pump Jet allows 100% of the power to go into propelling the boat. No loss of power is experienced from the use of feeding scoops or directional change to the water. The Pump Jet offers a significant decrease in the propeller projected frontal area, in addition to reducing the risk of personal injury due to contact from the conventional open propeller.</p> <p>Through the years several models have been build for the following motors:  <b>Johnson/Evinrude</b> (25, 30, 40, 50, 55, 60, 70, &amp; 140 HP); <b>Mercury</b> (9.9, 25, 40, &amp; 90 HP); <b>Mariner</b> (40 &amp; 50 HP); <b>Honda</b> (45 HP); <b>Suzuki</b> (40 HP); <b>Tohatsu</b> (25 &amp; 30 HP); and <b>Yanmar Diesel</b> (36 HP).            Work continues on 2 &amp; 4 stroke in other sizes as markets directs.</p> <p>To convert Johnson/Evinrude Outboards.</p> <p>Price: <b>\$1,000</b> to Convert 25 to 30 HP Outboards  <b>\$1,200</b> to Convert 40-60 HP Outboards</p>



## Listing of Current Intervention Devices

Company Contact Information	Illustration of Product	Description of Product
<p>Sword Marine Technology            1815 N. US Highway 1,            Ormond Beach, FL 32174            Phone: 386-676-7685            Fax: 386-676-0164            Email: <a href="mailto:info@swordmarine.com">info@swordmarine.com</a>  <a href="http://www.swordmarine.com/default.htm">http://www.swordmarine.com/default.htm</a></p> <p style="text-align: center;">Patented water jet drive system</p>	<div style="text-align: center;">  <p><b>The JetPac™</b></p> </div>	<p><b>Water Jet Propulsion System:</b></p> <p>The JetPac™ uses clean automotive engines, both diesel and gasoline, to power it's patented water jet drive system. Manufacturer claims: it's low emissions, low noise, low fuel consumption and low draft are just some of the advantages that make the JetPac™ outboard the best choice for consumers and the environment.</p> <p style="text-align: center;">150 HP &amp; 200 HP Diesel            275 HP &amp; 300 HP Gasoline</p> <p>Price: <b>\$18,000 to \$22,000</b>, complete (this includes cables, controls, gauges, etc., about everything but the boat and battery).</p>

## **SAFE MARINE LTD**

P.O. Box 100954

N.S.M.C

Auckland, New Zealand [safemarine@xtra.co.nz](mailto:safemarine@xtra.co.nz)

<http://www.propguard.co.nz/index.html>

### **General Description:**

The damage an unguarded propeller can do in seconds lasts a lifetime!

Prop Guard provides the following great features:

Protection to swimmers and divers in the water.

Protects propeller from prop strikes when used in and around rocks and other water hazards allowing safe operation in shallow water.

Reduces the chances of rope entanglement.

Easy installation.

#### Size Chart

Prop Guard 001

Yamaha 3AMH,4ACMH,5CMH,F4A

Mercury 2.5, 3.3

OMC 2.3, 4, 5.5

Honda BF2DX

Prop Guard 002

Yamaha 8CMH

Mercury 4, 5

OMC 2.3, 4, 5.5

Honda BF5K

Prop Guard 003

Yamaha 8CMH,FT8D/F8C,F15A

Mercury 8, 15

OMC 9.9, 15

Honda BF8D1, BF10D1, BFP10D1, BF15AX

Prop Guard 004

Yamaha 25NMH, 25A

Mercury 25, 20 4 stroke

OMC

Honda BF25

## Propeller Safety Guard

Email: [info@allinflatables.com](mailto:info@allinflatables.com)

[www.allinflatables.com/shopping/custom/guards.html](http://www.allinflatables.com/shopping/custom/guards.html)

### 90709 Propeller Safety Guard

Guard = 9" diameter (['A' measurement](#)) for prop. 7" to 8" diameter

**Sale Price: \$279 (US)**

### 90910 Propeller Safety Guard

Guard = 10" diameter (['A' measurement](#)) for prop. 8" to 9" diameter

**Sale Price: \$289 (US)**

### 91011 Propeller Safety Guard

Guard = 11" diameter (['A' measurement](#)) for prop. 9" to 10" diameter

**Sale Price: \$295 (US)**

### 91112 Propeller Safety Guard

Guard = 12" diameter (['A' measurement](#)) for prop. 10" to 11" diameter

**Sale Price: \$299 (US)**

### 91213 Propeller Safety Guard

Guard = 13" diameter (['A' measurement](#)) for prop. 11" to 12" diameter

**Sale Price: \$309 (US)**

### 91314 Propeller Safety Guard

Guard = 14" diameter (['A' measurement](#)) for prop. 12" to 13" diameter

**Sale Price: \$319 (US)**

### 91516 Propeller Safety Guard

Guard = 16" diameter (['A' measurement](#)) for prop. 14" to 15" diameter

**Sale Price: \$349 (US)**

### 91617 Propeller Safety Guard

Guard = 17" diameter (['A' measurement](#)) for prop. 15" to 16" diameter

**Sale Price: \$375 (US)**

**ATTENTION:** Maximum HP and Speed Ratings

<b>Recommended</b>	<b>Max. HP</b>	<b>Max. MPH</b>	<b>Max. KPH</b>
90709	8	20	32
90910 to 91415	120	40	64
91516 & 91617	200	30	48

**Important Sizing Instructions - For Propeller Safety and Line Guards (Measurement "A" is the important one)**

**To select correct guard:**

Measure the distance from under the anti-cavitation plate to the bottom of the skeg. **See "A" on drawing.**

**Example:**

If this distance measures 12", the Guard diameter should be 12".

**Select:** Model 91112 Safety Guard

**Or:** Model 91112-4 Line Guard

The propeller diameter is always less than the distance from under the anti-cavitation plate to the bottom of the skeg, usually at least 1" to allow for ½" clearance below anti-cavitation plate and ½" above the bottom of the skeg. **To select Guard size by propeller diameter only is not recommended.** The above mentioned example is the correct selection guide.

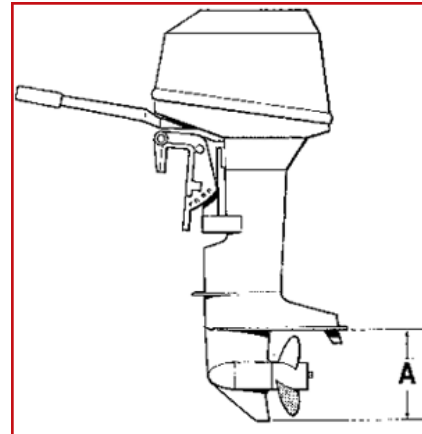

**PROP GUARD MARINE, INC.**  
P.O. BOX 630  
WESTCLIFFE, CO 81252  
Phone: (719) 783-2639  
Fax (719) 783-0230  
Email: [info@propguardmarine.com](mailto:info@propguardmarine.com)  
[www.propguardmarine.com/index.html](http://www.propguardmarine.com/index.html)

## PROP GUARD® MEASUREMENT GUIDE

To obtain and select your Prop Guard®, please select from the chart below:

Prop Guard® Chart:	Suggested Retail Price
9 -XP Prop Guard® (Safety White) fits 5hp to 9hp	<b>\$116.95</b> Plus Shipping
9" Prop Guard® (Safety Yellow) fits 9.9hp to 20hp (except Big Foot & High Thrust, Require 11")	<b>\$136.95</b> Plus Shipping
11" Prop Guard® (Safety Orange) fits 25hp to 35hp (except Big Foot & High Thrust, Require 13")	<b>\$144.95</b> Plus Shipping
13" Prop Guard® (Safety Blue) fits 40hp to 65hp (except Big Foot & High Thrust, Require 14")	<b>\$159.95</b> Plus Shipping
14" Prop Guard® (Safety Red) fits 70hp to 100hp (except Big Foot & High Thrust, Require 16")	<b>\$163.95</b> Plus Shipping
16" Prop Guard® (Safety White) fits 110hp to 350hp (All Stern Drives & Volvo Dual)	<b>\$175.95</b> Plus Shipping

**Prop Guards will fit all Manufacturers Outboards and Stern Drives. *Note: All hp's with Big Foot & High Thrust applications require next size up.***

**ALL APPLICATIONS of the 13", 14", and 16" Prop Guards are for PONTOON AND DECK BOATS, and any other application that the vessel does not exceed 25 mph (until our new design comes out).**

To obtain optimal performance out of your motor with the Prop Guard® installed, *you may need to change your propeller diameter:* 9" Prop Guard® up to 8.5" prop, 11" Prop Guard® up to 10.5" prop, 14" Prop Guard® up to 13.5" prop, and 16" Prop Guard® up to 15.5" prop.

The closer the prop blades are to the Prop Guard® rings, it will optimize your performance, handling and will not create a drag. Your motor will also have to be trimmed to a setting of optimal performance (**Refer to Fig. B**).

Be sure the Prop Guard® you purchase is the correct size. Place it on your motor with Grip Clamps first **and CHECK YOUR CLEARANCES BEFORE DRILLING HOLES AND MOUNTING.**

Manufacturer will not warrant your Prop Guard® should you drill into Prop Guard® and find you have purchased the wrong size.

Above all, please take your time in measuring and selecting the proper size Prop Guard®.

Consult your Marine Dealer or bring your motor by for an inspection for proper size.

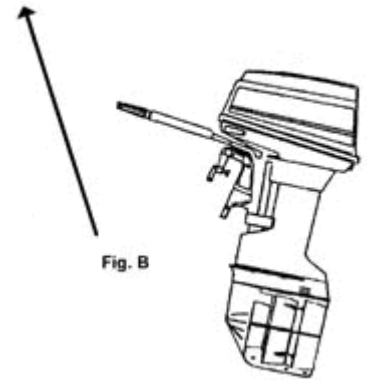

### Prop Guard Installation Instructions

**Time required: About 25-30 minutes. Don't be in a hurry!**

Tools needed: Drill, 5/16" bit, 1/2" box end or socket wrench, C-clamps or Grip clamps.

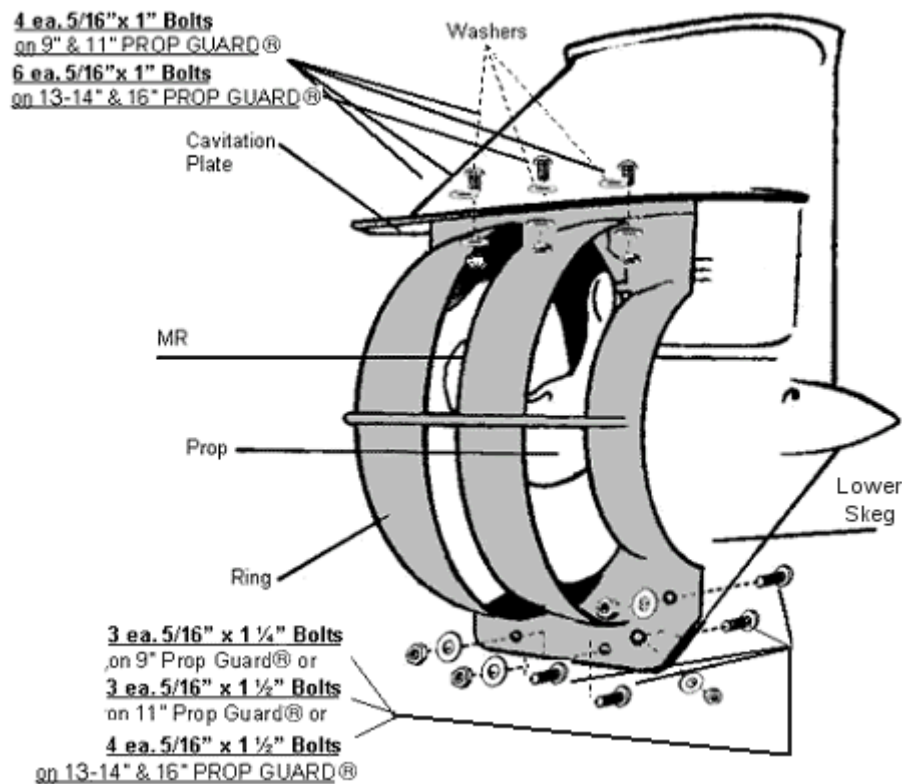

1. Place the Prop Guard on the underside of the cavitation plate. Align the guard so that equal distance exists between the guard and the prop when the propeller revolves inside the guard. The guard should be positioned as far forward on the cavitation plate as possible. Note: the mounting surface of the guard should remain flat against the cavitation plate. The use of a hand file may be needed to remove any imperfections in the lower surface of the cavitation plate and the lower skeg.

2. Clamp the guard to the cavitation plate using C-clamps or Grip clamps. Insert bolts, washers and Nyloc nuts through bottom of pre-drilled holes at bottom of rings and loosely tighten.

3. Make certain that the guard is square with the cavitation plate, propeller and lower skeg. PROPELLER MUST BE IN LINE WITH MIDDLE RING PER ILLUSTRATION (MR) MIDDLE RING.
4. Drill 2 holes through the cavitation plate and guard on each side. Insert bolts, washers and Nyloc nuts as illustrated and loosely tighten.
5. Drill 1 hole through lower skeg, per illustration. Insert bolt, washer and Nyloc nut, tighten securely. Now tighten cavitation bolts. REMOVE CLAMPS !!!
7. EXTREMELY IMPORTANT: MAKE SURE YOUR MOTOR IS TRIMMED TO OBTAIN MAXIMUM PERFORMANCE OF YOUR PROP GUARD.

MariTech Industries  
 6680 Lockheed Dr.  
 Redding, CA 96002-9003  
 Phone: 530-226-7414  
 Email: [info@maritechsafety.com](mailto:info@maritechsafety.com)  
<http://www.maritechsafety.com/main.php?p=home>



MariTech Industries - Marine Safety Innovations

**The SwimGuard Spec Sheet**

Please provide the following information when placing your order:

If you are ordering with our [On-Line Secure Order Form](#), please fill out the form below ahead of time and submit it so we will have all the important information about your needs.

Thanks !

**Measurements:**

Please measure accurately, and indicate the dimensions in inches.

NOTE: DIMENSION "A" IS FROM NOSE OF HOUSING TO END OF CAVITATION PLATE

Make:  Model:  Year:

Propeller Size:  Horsepower:

- A. Length of Cavitation Plate (from motor to end of plate)
- B. Bottom of Cavitation Plate to bottom of Skeg
- C. End of Cavitation Plate to Housing
- D. Bottom of Cavitation Plate to center of Propeller
- E. Length of Housing
- F. Width of Cavitation Plate at the end
- G. End of Cavitation Plate to Housing

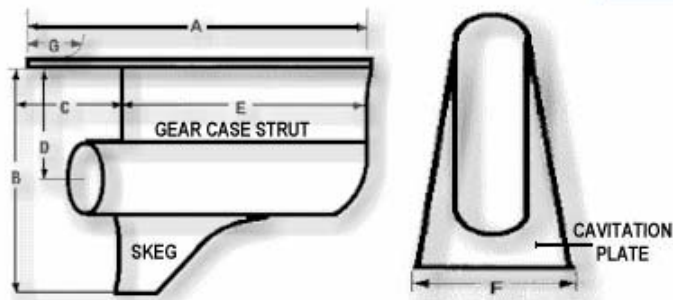

Name:  \*required field  
 E-Mail:  \*required  
 Telephone:  \*required  
 Address:   
 City:  State:  Zip:



# Product Installation Overview

## SwimGuard



### 1. Harness Installation: No Drilling Required!

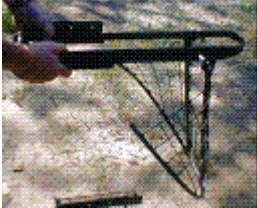

- a) Wrap the mounting harness around the front of the lower unit. The front screen can remain in place during the step.
- b) Pull the mounting harness as far forward as possible capturing the cavitation plate between the harness brackets.
- c) Bring the ends of the mounting harness together securing it with the provided hardware.

### 2. Guard Installation:



- a) Once the mounting harness is secured, place the guard into position by lining up the mounting holes. Secure the guard using the provided hardware.
- b) Bring the front screen into position and secure it to the guard frame using the provided hardware.

Note: Each SwimGuard is customized to the size and configuration of the lower unit and can be installed with the vessel in or out of the water.

**Average installation time: 30 minutes**

**RingProp PLC**  
 Haslar Marine Technology Park  
 Gosport, Hants P012 2AG  
 England  
 Email: [Info@ringprop.com](mailto:Info@ringprop.com)  
<http://www.ringprop.com>



## RingProp Range Availability.

Engine Brand	HP	Part Number	Material	Pitch	Dia.	Std. Prop Pitch	Available	Torc-Loc® Hub Kits
Mercury, Yamaha, Honda, Tohatsu	40 - 60	C03-040050	Al	12.7	9.8	14 - 15	Yes	TL-010010
Mercury, Yamaha, Honda, Tohatsu	40 - 60	C03-040020	Al	10	10.4	11 - 12	Yes	TL-010010
Mercury, Yamaha, Honda, Tohatsu	40 - 60	C03-040030	Al	11.7	10.1	13 - 14	Yes	TL-010010
Mercury	25	C03-040040	Al	10.5	9.6	11 - 12	Yes	TL-010020
Mercury	25	C03-040010	Al	9	10	10 - 11	Yes	TL-010020
Mercury, Yamaha, Honda, Tohatsu	60 - 115	C03-050060	Al	18.7	13	20 - 21	Apr	TL-010030
Mercury, Yamaha, Honda, Tohatsu	60 - 115	C03-050070	Al	17	13.3	18 - 19	May	TL-010030
Mercury, Yamaha, Honda, Tohatsu	60 - 115	C03-050080	Al	15	13.8	16 - 17	Jun	TL-010030
Mercury, Yamaha, Honda, Tohatsu	40 - 60	C03-050090	Al	11	11.6	12 - 13	Apr	TL-010010
Mercury, Yamaha, Honda, Tohatsu	40 - 60	C03-050100	Al	10	11.8	11 - 12	May	TL-010010
Mercury, Yamaha, Honda, Tohatsu	40 - 60	C03-050110	Al	9	*	10 - 11	Jun	TL-010010
Yamaha, Honda, Tohatsu	20 - 30	C03-050150	Al	8*	*	*	Jun	TL-010070†
Yamaha, Honda, Tohatsu	20 - 30	C03-050160	Al	9*	*	*	Jul	TL-010070†
Mercury, Yamaha, Honda, Tohatsu	40 - 60	C03-051010	SS	11	11.6	12 - 13	Jan	TL-010010
Mercury, Yamaha, Honda	135 - 225	C03-051030	SS	19*	*	*	May	TL-010060†
Mercury, Yamaha, Honda	135 - 225	C03-051020	SS	17*	*	*	May	TL-010060†

\* denotes "To Be Confirmed". † there may be further hub kits.

Additional engines will be covered by the above once testing has been completed.



# Product Installation Overview

Virtual Lifeline (wireless lanyard)



## 1. Control Module installation:



- a) Locate a secure, yet accessible location to mount the control module.
- b) Most prefer to place the control module at the helm.

## 2. Wiring procedure (three wires from the control module):

- a) Locate and cut/splice the boats ignition wire.
- b) Connect the red wire to the ignition side of the splice.
- c) Connect the white wire to the coil side of the splice.
- d) Connect the black wire to ground.

## 3. Sensors are worn by the operator and passengers alike

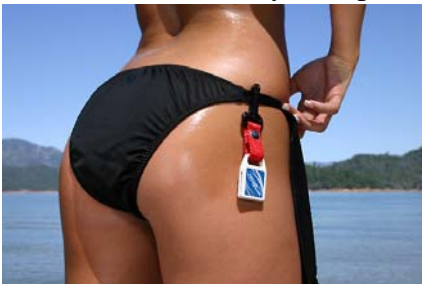

Average installation time: 1 hour

# Product Installation Overview

PropStopper (ladder interlock)



## 1. Control Module installation:



- Locate a secure, yet accessible location to mount the control module.
- Most prefer to place the control module in the engine compartment, or at the helm.

## 2. Wiring procedure (three wires from the control module):

- Locate and cut/splice the boat's ignition wire.
- Connect the purple wire to the ignition side of the splice.
- Connect the yellow wire to the coil side of the splice.
- Connect the black wire to ground.

## 3. Sensor cable installation (stationary sensor-mate):

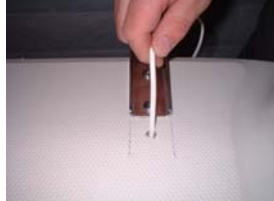

- Within the alignment of the stowed ladder position, drill a hole for the sensor cable.
- Run the sensor cable through the hole into the engine compartment.
- Secure the sensor cable housing.
- Connect the sensor cable to the control module.

## 4. Ladder sensor installation:



- Secure the ladder sensor in-line with the sensor cable (stationary sensor-mate).
- Various ladder configurations will require various sensor assemblies

**Average installation time: 1 hour**