



**INSTALLATION AND
OPERATING INSTRUCTIONS**

FOR

**THE HARDY
OUTSIDE WOOD
BURNING HEATER**

Model - H25

**HARDY MANUFACTURING
COMPANY, INC.**

12345 ROAD 505

PHILADELPHIA, MS 39350

PHONE: (601) 656-5866

FAX: (601) 656-4559

www.hardyheater.com



THIS PAGE INTENTIONALLY LEFT BLANK

INTRODUCTION

Thank you for purchasing the original all stainless steel Hardy Outside Woodburning Heater. It represents the result of many years of Hardy experience and the input of Hardy customers in the production of a top quality heater. With the purchase of this Hardy Heater, you can now appreciate the high degree of craftsmanship and reliability that have made The Hardy the leader in the Outside Woodburning Heater field. This manual will provide you with a good basic understanding of the installation and operation of this heater.

THIS MANUAL INCLUDES IMPORTANT SAFETY INFORMATION.

Your new heater should have the following:

- (1) Owner's manual complete with Installation and Hook-Up Instructions
- (2) Warranty & Return Warranty Card
- (3) A tube of silicon (located in the firebox for shipping)
- (4) Smoke stack and condenser tank stack both with trim (located in firebox for shipping)
- (5) Six cast iron grates (located in firebox)
- (6) One Air tube & Two Channel Beams (located in firebox)
- (7) Shovel (located in the firebox for shipping)
- (8) Stainless steel panel and insulation that will be located between the firebox door & ash door after installation of the heater.
- (9) Welded steel flame baffle (located in firebox)
- (10) 3/8" steel plate

Should your heater not have any of these items or if you have any questions regarding the operation or maintenance of your heater, please consult you local Hardy dealer.

Again, thank you for purchasing a Hardy Heater.

Sincerely,

Frank L. Moore
President

Hardy Manufacturing Co., Inc.

(MODEL H25)

Please fill in the following information

Hardy Model _____

Serial Number _____

Date of Purchase _____

Date of Installation _____

Dealer Purchased from _____

Dealer Address _____

Dealer Phone Number _____

Please keep this manual with all other important papers. The information in this manual is necessary for the installation, operation and proper use of this unit. If you should ever have a problem or question please refer to this manual or have it available when you call your Hardy Dealer or Hardy Manufacturing Company, Inc.

HARDY MANUFACTURING COMPANY, INC.

12345 ROAD 505
PHILADELPHIA, MS 39350
PHONE: (601) 656-5866
www.hardyheater.com

(MODEL H25)

SAFETY PRECAUTIONS WARNING

Do not operate this equipment for other than its intended purpose nor other than in accordance with the instructions contained in this manual and all other instructions accompanying the unit.

For units covered by this instruction book, it is important to observe safety precautions to protect yourself from possible injury. Among the many considerations, you are advised to:

- Observe all safety stickers on the unit.
- This unit must be wired by a qualified electrician in accordance with the National Electrical Code.
- Never use any type of petroleum product, petroleum based product, charcoal starter, lighter fluid, or any other flammable accelerant to start your unit.
- Always open the ash door (bottom) before you open the firebox door (top).
- Never leave the doors open, always latch the doors securely.
- Always use proper care when installing, operating and maintaining the unit.
- Do not modify the unit.
- Do not substitute repairs which can be provided by your dealer, distributor, or Manufacturing Company.

Failure to heed this warning or any additional warnings on the unit may result in an accident causing personal injury.

THIS PAGE INTENTIONALLY LEFT BLANK

OUTDOOR WOOD HEATER BEST BURN PRACTICES

1. Read and follow all operating instructions supplied by the manufacturer.
2. FUEL USED: Only those listed fuels recommended by the manufacturer of your unit. Never use the following: trash, plastics, gasoline, rubber, naphtha, household garbage, material treated with petroleum products (particle board, railroad ties and pressure treated wood), leaves, paper products, and cardboard.
3. LOADING FUEL: For a more efficient burn, pay careful attention to loading times and amounts. Follow the manufacturer's written instructions for recommended loading times and amounts.
4. STARTERS: Do not use lighter fluids, gasoline, or chemicals.
5. LOCATION: It is recommended that the unit be located with due consideration to the prevailing wind direction.
 - Furnace should be located no less than 100 feet from any residence not served by the furnace.
 - If located within 100 feet to 300 feet to any residence not served by the furnace, it is recommended that the stack be at least 2 feet higher than the peak of that residence.

Chimney Height Installation Scenario

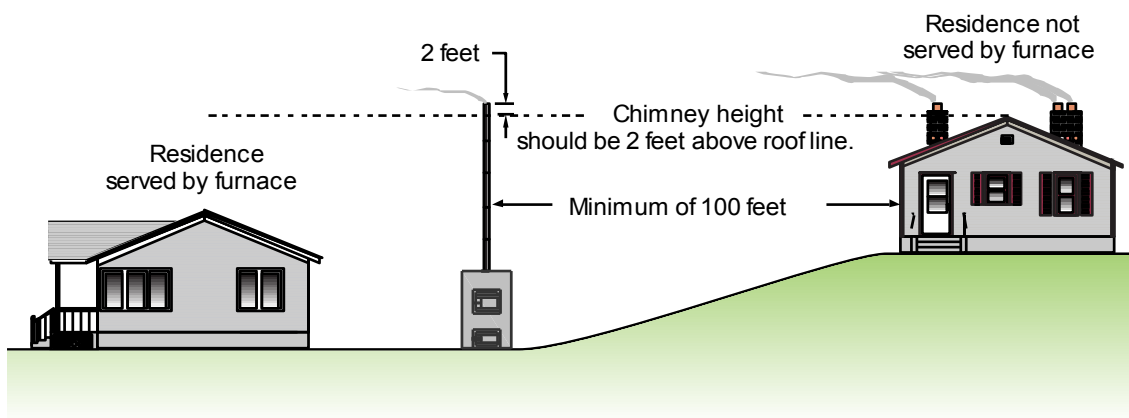

6. Always remember to comply with all applicable state and local codes.



OUTDOOR FURNACE MANUFACTURERS CAUCUS

(MODEL H25)

THE HARDY OUTSIDE WOODBURNING HEATER

How does an outside heater heat my home?

The Hardy outside wood heater is designed to save the most energy and provide the most comfortable heating available. It heats your home by heating a stainless steel tank filled with water, which surrounds the firebox of the outside heater. The heater is basically a non pressurized boiler with an atmospheric vent. This hot water is then circulated through underground hot water pipes to a water coil inside your existing central duct system. The Hardy Heater can be connected to any existing hydronic heating system that operates at 180 degrees or less.

How does THE HARDY heat water for household use?

A plate heat exchanger (optional) is installed in the hot water circulator line. When you open a hot water faucet inside your home, the cold water passes through the other side of the heat exchanger and the water going to your hot water heater is preheated. The only energy required is maintaining the hot water temperature. The plate heat exchangers can be used for pools, dairies and other domestic hot water needs.

How do the Thermostat Controls work?

The only visible addition to the heating system inside your home is the thermostat which is located neat the existing thermostat. The two thermostats are installed so that if the outside wood heater is not in operation, your existing unit will automatically take over to maintain your household temperature. The wall thermostat which regulates the heat from the outside heater performs two functions; when it senses your need for heat according to your temperature setting, it turns the water pump on to circulate the hot water through the coil and also turns the blower on inside your central unit to force air across the hot coil. This forces hot air into your central duct system. The outside heater has a hot water thermostat which senses the water temperature of the unit. If the water is not as hot as the thermostat setting then the combustion air intake is automatically opened and remains open until such temperature is attained.

Where should an Outside Wood Burning Heater be located?

The outside unit should be located at least 10 feet from your home so that all fire danger is removed from your home. The unit may be installed as much as 100 feet away and still heat your house and hot water. If the unit is located more than 100 feet away, you may experience some heat loss on the water going to your water heater. Locate the outside wood heater where it will be convenient for refueling and wood storage. All water and power lines are installed underground between the house and the outside wood heater.

TABLE OF CONTENTS

SECTION I:	General Information	
	1-1 Specifications	1
	1-2 Heater Component Parts	2
SECTION II:	Installation of Heater	
	2-1 Location of Heater	3
	2-2 Hull Removal	5
	2-3 Set-Up of Grates	6
	2-4 Location of Plumbing & Electrical Lines	7
	2-5 Connection of Power to Heater	8
	2-6 Wiring Diagram	9
	2-7 Plumbing Instructions	10
	2-8 Filling the Heater with Water	11-12
SECTION III:	Connection to Central Heating/AC System	
	3-1 Connection to Central Unit with existing Blower Coil	13-15
SECTION IV:	Connection to Hydronic Heating Systems (Baseboard)	
	4-1 Connection to Hydronic System with existing 24 Volt Transformer	18-19
	4-2 Typical Diagram for Plumbing Hydronic System	20
SECTION V:	Plumbing Options for Domestic Water	
	5-1 Plate Heat Exchanger for Domestic Water	21
SECTION VI:	Heater Operation	
	6-1 Firing the Heater	22
	6-2 Water Temperature	22
	6-3 Wood Usage	22
	6-4 Moisture in the Firebox	22
	6-5 Improper Burning	23
	6-6 Ash Removal	23
SECTION VII:	Service Information	
	7-1 Water Circulation System	24
	7-2 Temperature Control System	25
	7-3 Preseason Heater Maintenance	26
	7-4 Trouble Shooting Guide	27-29

THIS PAGE INTENTIONALLY LEFT BLANK

SECTION I

GENERAL INFORMATION

1 – 1 Specifications

Type of fuel – Wood

For outdoor use only

Electrical Rating 115 VAC/ 60 HZ / 1PH
MFS-15 AMP, MCA-15 AMP

Clearance to Combustibles

Top, Rear, Sides	18"
Chimney Connector	18"
Front	48"
Flooring	Non Combustible

Water Capacity

H25 – Holds Approximately 160 Gallons of Water

HEATER DIMENSIONS

<u>Description</u>	<u>Width</u>	<u>Depth</u>	<u>Height</u>	<u>Weight</u>
H25 – 250,000 BTU	40"	60 ¼"	59 ½"	1000 lbs.

FIREBOX SIZES

<u>Description</u>	<u>Width</u>	<u>Depth</u>	<u>Height</u>
H25 – 250,000 BTU	34"	42"	44" + 8" for Grates

Section I 1-2

Heater Component Parts (Model H25)

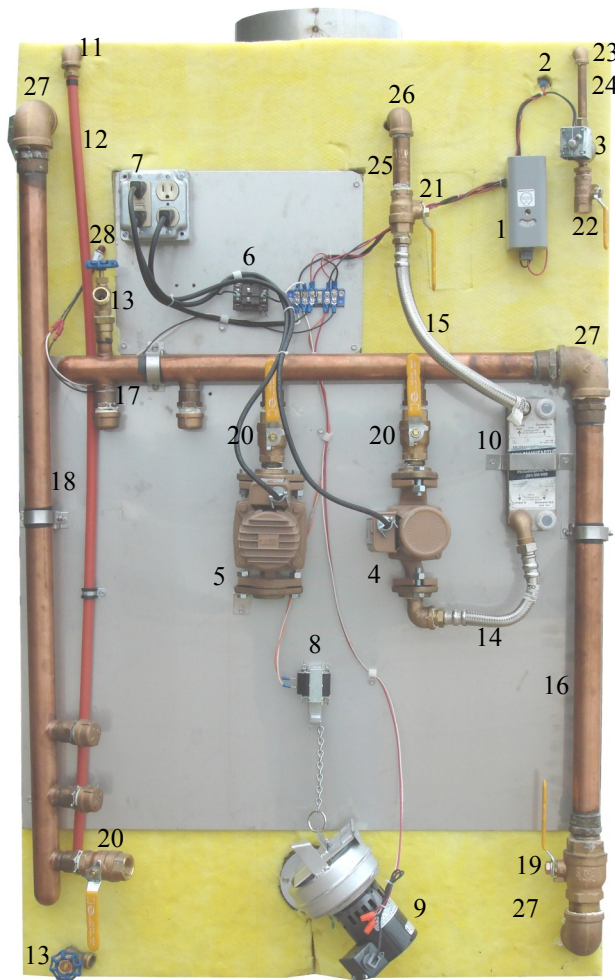

<u>Legend</u>	<u>Part No.</u>	<u>Description</u>
1)	2000.16	Aquastat
2)	1100.28	Low Water Switch
3)	1100.00	Water Solenoid
4)	508.09	Taco 008
5)	502.08	Taco 009
6)	2000.52	Relay
7)	2004.00	GFCI
8)	2001.05	Damper Solenoid
9)	2002.30	130 CFM Blower
10)	300.02	Plate Exchanger
11)	600.10	1/2" Brass elbow
12)	810.00	1/2" Overflow pipe
13)	607.42	3/4" Male Boiler Drain Valve
14)	700.05	3/4" x 10" SS Flex Line
15)	700.18	3/4" x 18" SS Flex Line
16)	900.80	1 1/2" Copper Supply
17)	900.85	1 1/2" Copper Pump Supply
18)	900.90	1 1/2" Copper Return
19)	607.47	1 1/2" Brase Ball Valve
20)	607.45	1" Brass Ball Valve
21)	607.12	3/4" Brass Ball Valve
22)	607.00	1/2" Brass Ball Valve
23)	600.05	1/4" Brass Elbow
24)	603.04	1/4" X 4" Brass Nipple
25)	603.28	3/4" X 4" Brass Nipple
26)	600.30	3/4" Brass Elbow
27)	600.48	1 1/2" Brass Elbow
28)	1100.30	Low Water Indicator Light

SECTION II

INSTALLATION OF HEATER

Section II 2-1 Location of Heater

The Hardy heater is designed to set outside the building to be heated. The unit must be located a minimum of 10 feet from the building. The unit should be installed upon a concrete pad. There are two typical options that we recommend.

Option 1 has the unit installed on concrete pad with the rear of the water tank flush with end of the pad. We recommend the pad to be 48" wide and 53" long minimum. If you add extra length it will allow ample concrete in front of the heater for loading wood and removing ashes. The space between the rear of the unit and the outside cover will allow a 4 inch water tight pipe or other means to insulate the plumbing and electrical lines to run directly into the ground. The outside cover can be removed by lifting it off the water tank on all four corners. This will allow you easy access for the connection of the plumbing and electrical lines.

Please see the illustration below for details.

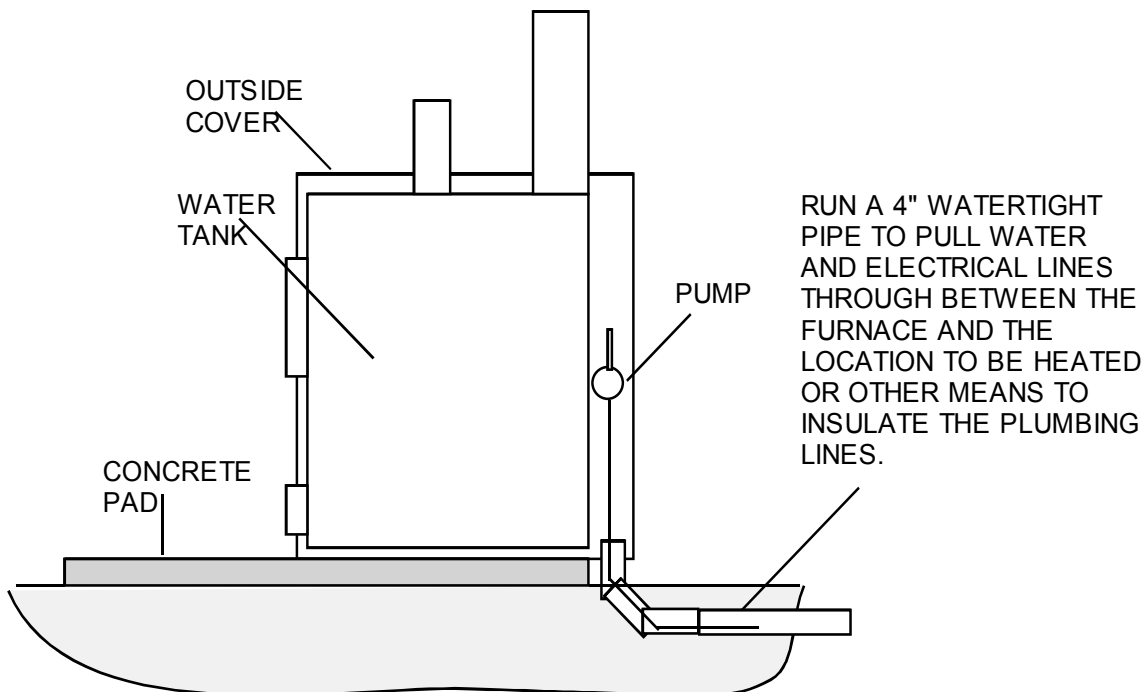

Heater over hanging pad (not to scale)

Option 2 illustrates the unit installed on a concrete pad with cut out in the pad for plumbing and electrical connection to run through. We recommend this pad to 48" wide by 65" minimum long. If you add extra length it will allow ample concrete in front of the heater for loading wood and removing the ashes. The 4" watertight pipe or other means to insulate plumbing that runs underground exits through this cut out to allow connections to the unit. The unit sits on the pad with the rear of the water tank flush or even with the front side of the cutout. The outside cover of the heater can be removed by lifting it from the water tank on all four corners. This will allow you easy access for the plumbing and electrical connections.

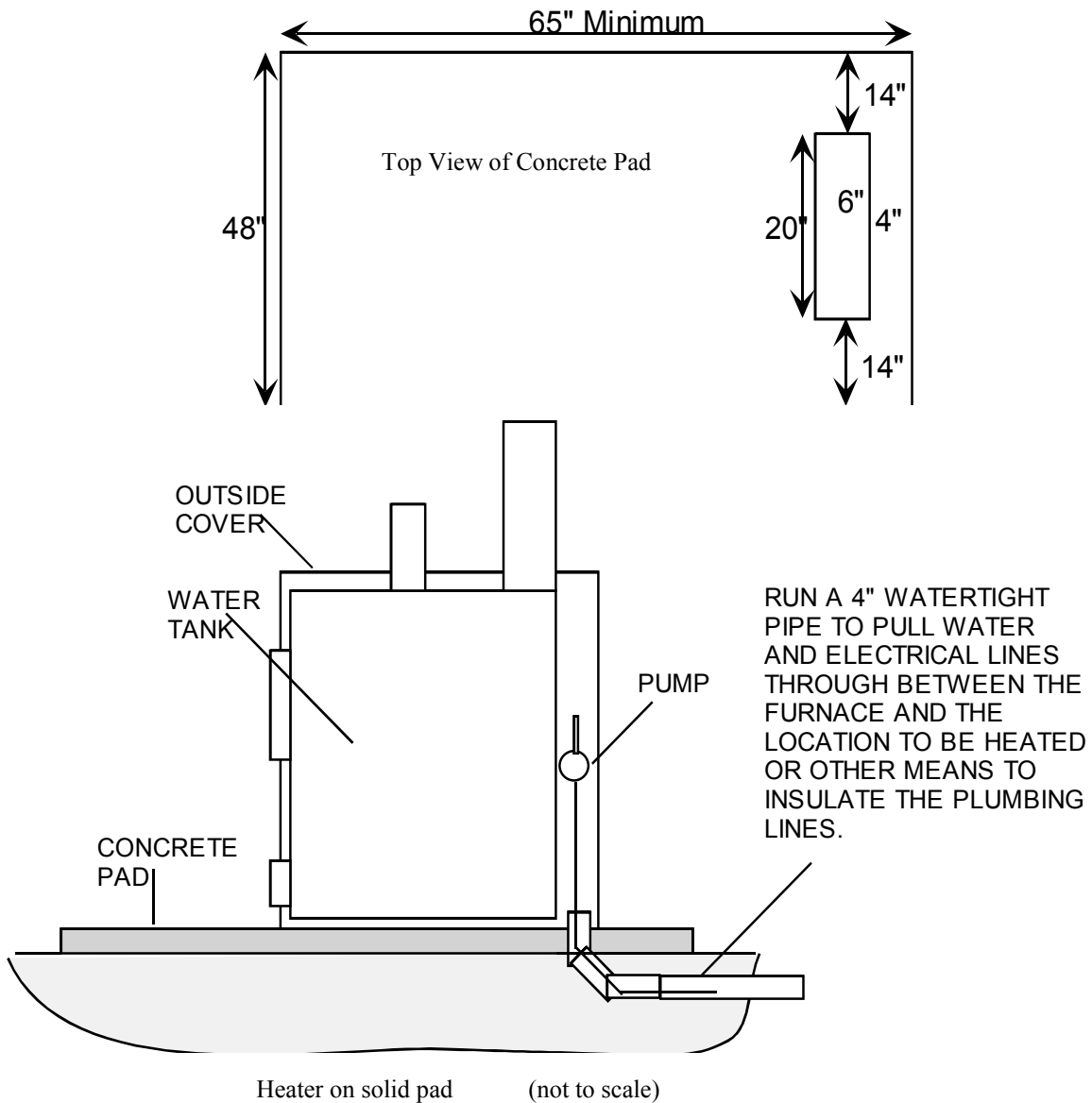

Section II 2-2 Hull Removal

After placing your new Hardy Heater upon the concrete pad, you are ready to continue the installation process. There are two methods to gain access to the rear of the heater to make plumbing and electrical connections.

The first and easiest method is to remove the screw holding the back door panel in place. The door is easily removed by lifting up on the handle and taking it out. With the back door removed, using a 5/16" wrench, remove the 8 metal screws that are located below the back door. There are four on each side that hold the panel in place. After the screws are removed, the panel should come out easily and allow access to the bottom of the unit to make plumbing and electrical connections.

The second method is the removal of the entire cover. With the back and the rectangular piece of stainless and insulation between the fire box and ash door removed, the outside cover can be lifted up and off as seen in the picture. To replace the cover simply repeat these steps in reverse order.



REAR



FRONT

First open the firebox door and remove everything from inside the heater except the air tube, two channel beams, the welded steel baffle, and the 3/8" steel plate. Stand the two channel beams up on the edge with flat side of channel over against the sides of the fire box.

Slide the 3/8" steel plate in the firebox across the air tube and channel beams under the drop down section of the fire box against the back wall. Install the grates across the air tube and the channel beams inline and end to end in front of the 3/8" steel plate. Stand the steel flame baffle up with the 5" support legs on the bottom facing the front of the heater. The openings should be facing and pushed against the drop down section. The picture below shows the proper way for grates, flame baffle and 3/8" steel plate to be installed. These grates are designed to be turned over if they warp.

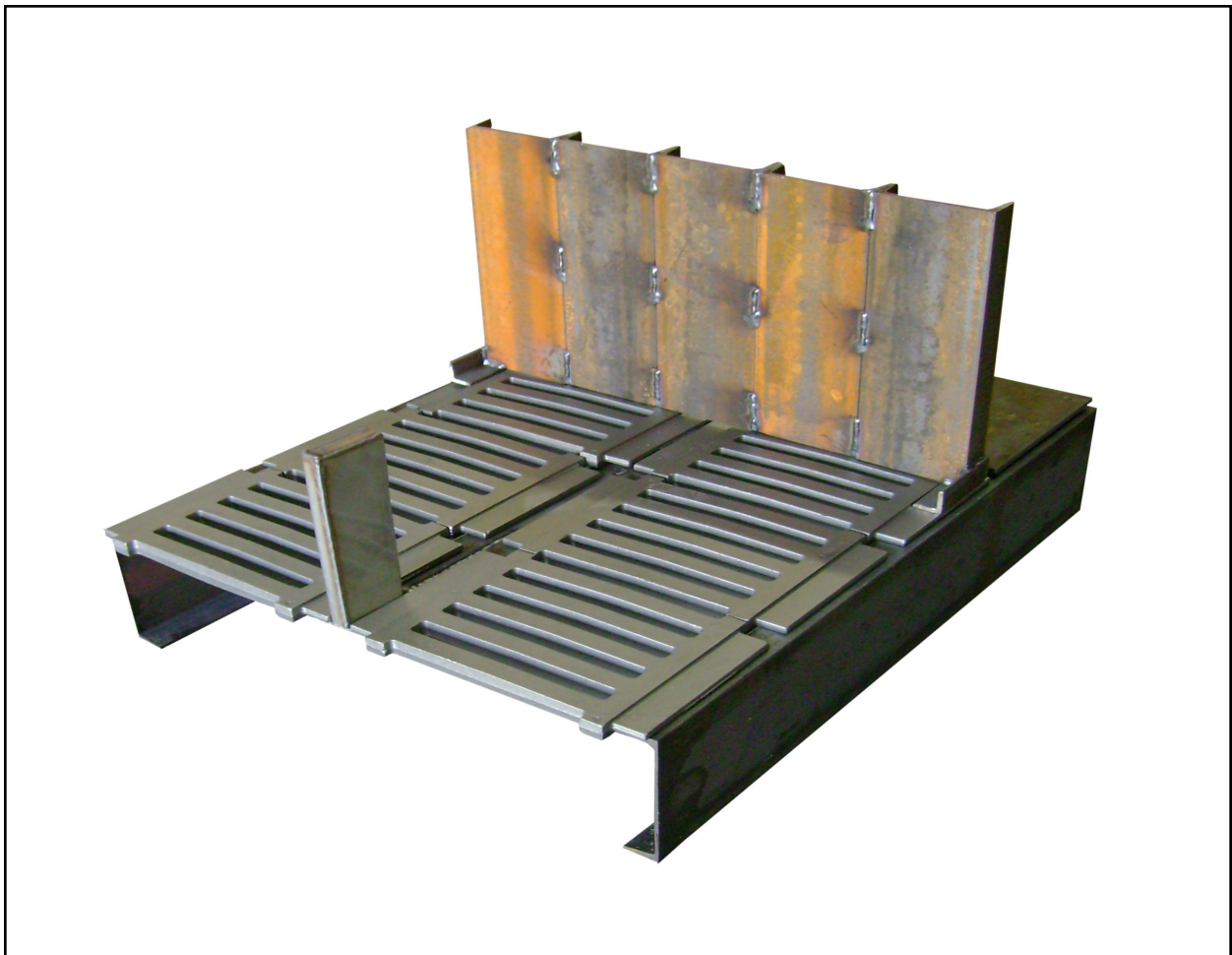

The plumbing and electrical lines for your unit must be installed underground. The water lines must be buried below the frost line to prevent freezing. The depth of the trench varies to different regions of the country. Be completely sure about the correct depth before the plumbing lines are installed underground.

A trench must be dug wide enough to accommodate a 4" watertight pipe or other insulation means. All plumbing and electrical lines should be run inside the 4" water tight pipe or other insulation means for a standard installation. If more than 1 zone is to be heated or more than 1 location is to be heated then an additional pipe, or insulation must be installed underground.

This pipe will run from the rear of the unit to the location to be heated. Inside the 4" watertight pipe is the water lines, thermostat wire, and electrical supply wire. The listing below describes each line and their function.

1. One water supply line to heating system
2. One water return line from heating system
(All of these must be at least 3/4" pipe and may require 1" because of longer distances or some hydronic applications.)
3. One 3 conductor thermostat wire
4. One #12/2 W/G UF underground Romex wire

If more than one location is to be heated, a second 4" or single 6" watertight pipe or other insulation means will need to be installed underground for the water lines and thermostat wires of the second location.

**This unit must be wired by a qualified electrician
in accordance with the National Electrical Code.**

1. The #12/2 W/G UF wire is run from the electrical system in the house through the 4" watertight pipe or other insulation means to the heater.
2. This wire will connect to the Ground Fault Circuit Interrupter (GFCI) on the back of the heater.
3. Install a Romex Connector in the bottom of the electrical makeup box, and insert Romex wire through this connector.
4. Connect the black wire to the brass screw on the line side of the GFCI receptacle.
5. Connect the white wire to the silver screw on the line side of the GFCI receptacle.
6. Connect the bare copper wire to the green screw on the GFCI receptacle.
7. After the wiring is complete check the receptacle with a circuit tester to determine if the polarity is correct, and to make sure the ground is connected. Press the test button on the GFCI receptacle the reset button should pop out indicating the interrupter is operating correctly. Push the reset button back to restore the GFCI receptacle to normal operation. This test should be done monthly to insure safe operation of the heater.
8. If moisture is allowed into Ground Fault Circuit Interrupter box, it will have a tendency to trip unwarranted. Measures should be taken to keep the box dry.

Section II 2-6 Wiring Diagrams (H25)

This equipment must be installed in accordance with the National Electrical Code.

CONNECTION DIAGRAM

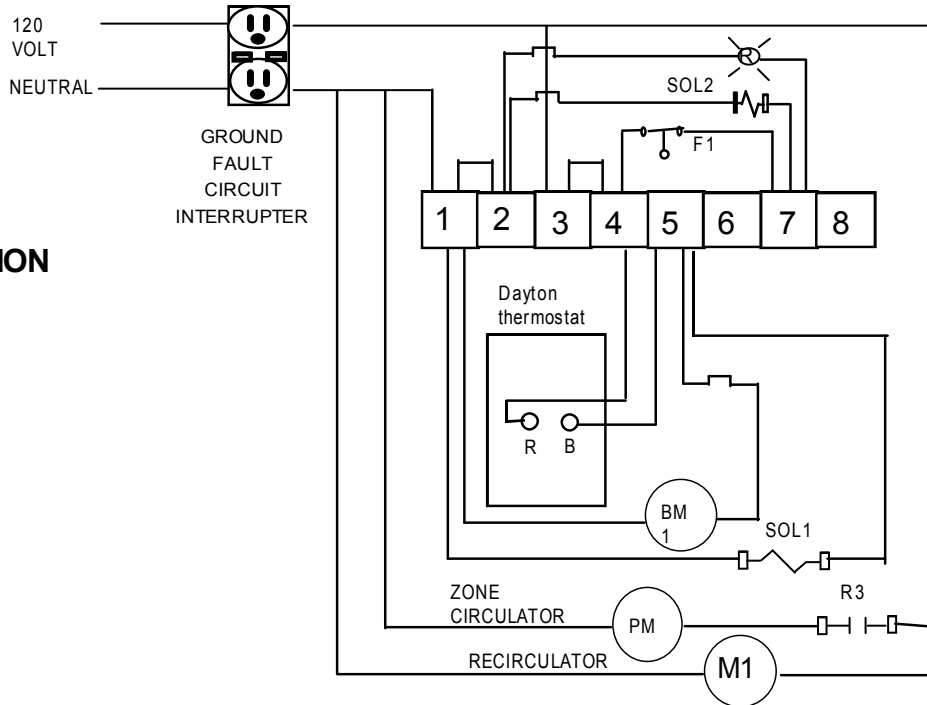

SCHEMATIC DIAGRAM

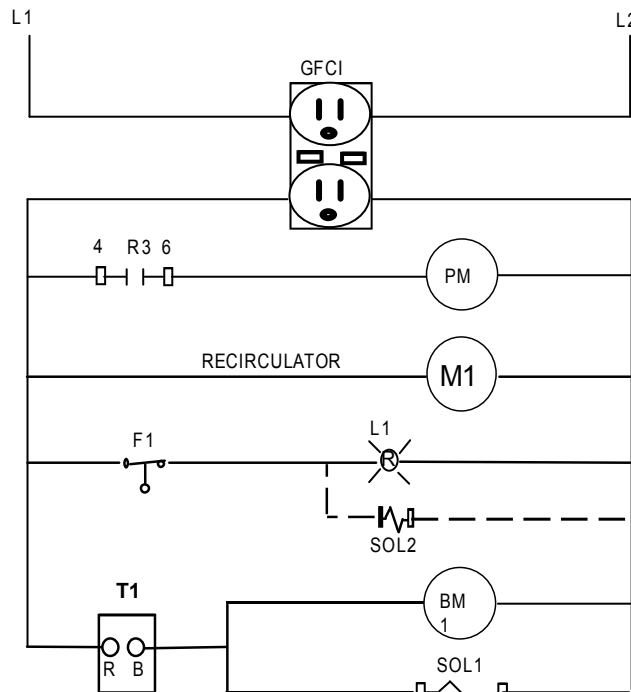

LEGEND

- GFCI GROUND FAULT CIRCUIT INTERRUPTER
- R3 CIRCULATOR PUMP RELAY
- PM WATER CIRCULATOR PUMP
- M1 RECIRCULATOR PUMP
- T1 DAYTON AQUASTAT
- BM1 DAMPER BLOWER MOTOR
- SOL1 DAMPER SOLENOID
- SOL2 WATER SOLENOID
- F1 LOW WATER SWITCH
- L1 LOW WATER LIGHT

Section II 2-7 Plumbing Instructions

Connection to Heating System

1. The pipe that will supply the heating system is connected to the under side of the pump. This pump is located on the right hand side of the heater (Noted by #3 in diagram).
2. The pipe that will carry the return water from the heating system is connected to the $\frac{3}{4}$ " brass tee located at the bottom left hand corner of the heater (noted by #4 in the diagram).

Water pipes must be designed for hot water service (ex. copper, cpvc, or Pex.) Pipes should be installed in a 4" watertight pipe or some other type of insulating means to prevent heat loss from heater to heating system. Use only copper, brass, or stainless steel fittings. Do not use galvanized or black iron.

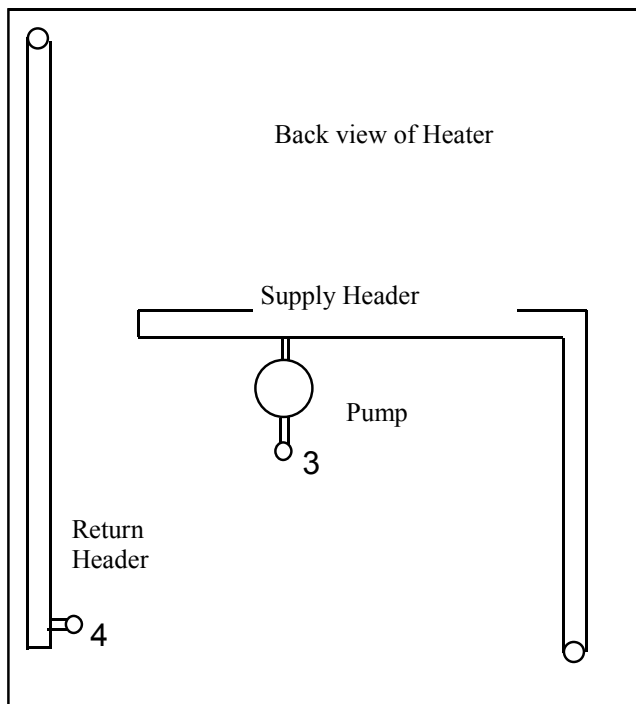

- 3) Supply to Heating System
- 4) Heating System Return

When you are ready to replace the cover, the hull can slide down over the heater. Make sure that the condenser tank and smoke stack opening come through the outside cover.

The space between the smoke stack opening and outside cover will need a bead of silicone applied to fill any openings. The condenser tank will also need to be sealed in this manner. The application of silicon to these openings is illustrated by the diagram on the next page.

Inside the firebox should be a rectangular piece of insulation and stainless steel. The insulation fits between the firebox and ash doors. The stainless steel slides between the two doors to protect the insulation.

After these steps, you can install the smoke stack which is a three foot section of pipe. The trim should be slid down the smoke stack until it sits on the outside cover.

The condenser stack must also be installed in the condenser stack opening. The trim should be slid down the smoke stack until it sits on the outside cover.

The condenser stack must also be installed in the condenser stack opening. The trim must also sit snugly upon the outside cover.

DO NOT SEAL THE CONDENSER TANK TO THE CONDENSER TANK LID. THIS IS THE WATER TANK VENT AND MUST NOT BE SEALED.

There are certain parts of the country that have high enough levels of chloride in the water to be harmful to stainless steel tanks. Even though the USDA allows up to 250 parts per million of chloride (salt) in the water as acceptable for drinking, experience has shown that chloride levels as low as 45 parts per million will eventually cause stress corrosion cracking in stainless steel tanks when water is heated. It is therefore required to use rain water or bottled water with chloride content of less than 15 parts per million or test the water supply for chloride to assure that the water supply does not exceed 45 parts per million. Call your Hardy dealer to get a chloride test on your water supply.

Fill your heater with water through the condenser stack opening. If the chloride content of your local water supply exceeds the specifications mentioned above and necessitates the use of bottled or rain water, please do so to maintain the warranty of your heater.

THE HEATER MUST BE FILLED WITH WATER BEFORE STARTING A FIRE.

There is a low water switch located in a fitting on the back of the heater. This low water switch operates a low water warning light and automatic water fill solenoid.

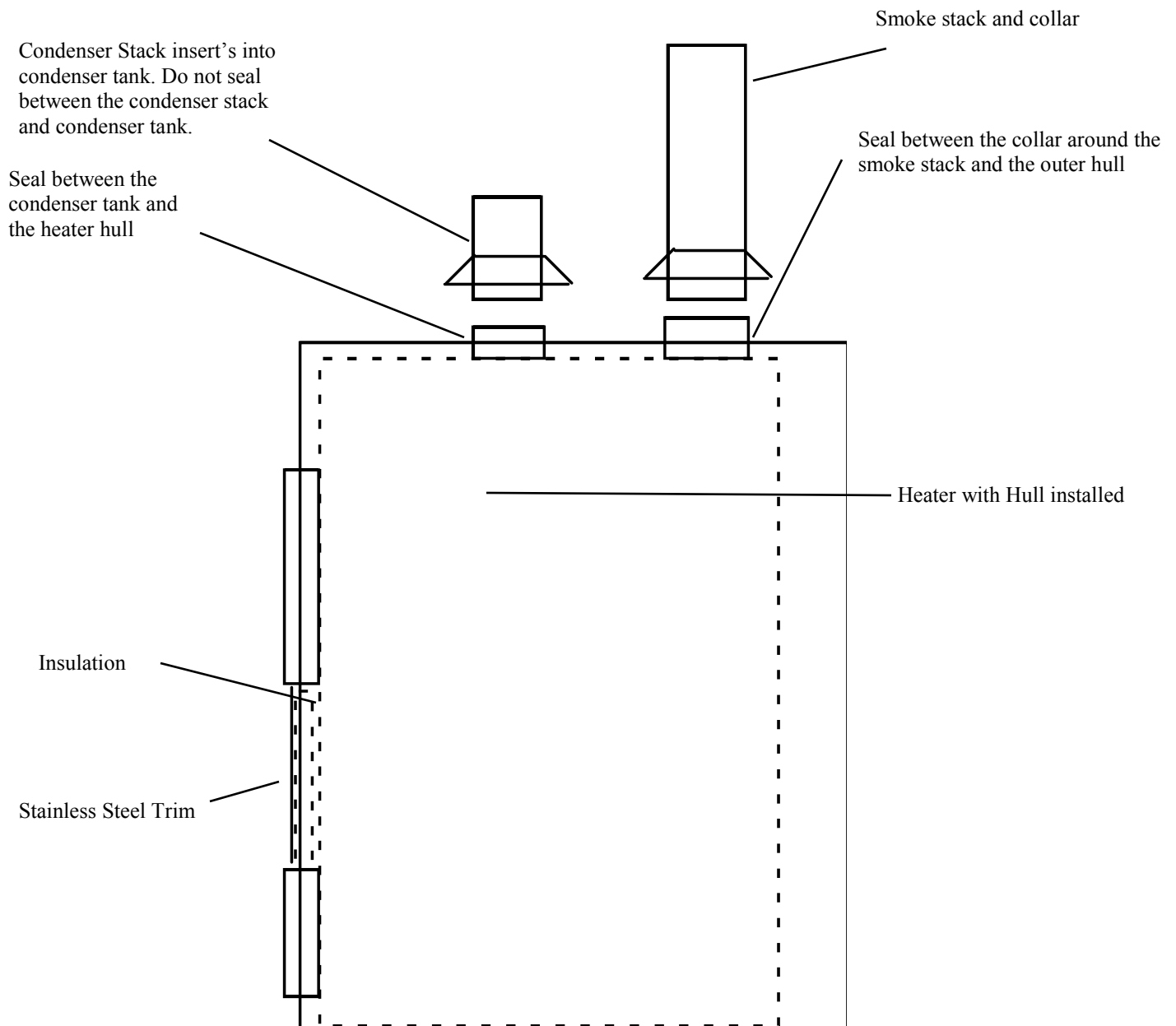

SECTION III

CONNECTION TO CENTRAL HEATING/AC SYSTEM

3-1 Connection to Central Unit with Existing Blower Relay

CONNECTED TO ONE CENTRAL HEATING/AC SYSTEMS THAT HAS AN EXISTING BLOWER RELAY AND ONE PUMP USING HONEYWELL RELAY R8222D FOR THE PUMP RELAY AND THE NEW BLOWER RELAY.

This unit must be wired by a qualified electrician in accordance with the National Electrical Code.

- 1 Run a three conductor thermostat wire from the wood heater to central unit in the house. This wire must be rated for underground use or be run inside a watertight pipe. The colors normally are red, white, and green.
- 2 At the heater connect the white wire to terminal 8 of the water pump relay (R-3).
- 3 Connect the red wire to one side of the low temperature sensor (the round disc with two terminals under the insulation near the center of the heater appx. 12" from the top). This is an option that prevents the plumbing of water less than 100°F but is not required. If you elect not to use this option, then only a two wire conductor is required, bypassing the low temperature sensor.
- 4 Connect a jumper wire from the other side of the low temperature sensor to terminal 7 of the water pump relay (R-3) and also connect the green wire to terminal 7 of R-3. If two wires are used then one is connected to terminal 7 and the other to terminal 8.
- 5 Inside the house:
 - A. Install the new wood heating thermostat next to the existing thermostat.
 1. Remove the cover on the new home heat thermostat to mount it on the wall. There is a round dial visible with an adjustable pointer. This is the heat anticipator. The dial also has a series of numbers. The pointer must be set to the highest number on the dial. On the Honeywell model # (t 822-1016), the pointer is turned counter clockwise as far as it can go.
- 6 Run a two conductor thermostat wire from the new thermostat to central unit:
 - A. The colors normally used are red and white.

NOTE: If you are not familiar with the control circuit of your central unit, do not continue beyond this point. Call a heating and air conditioning serviceman to complete the wiring. Improper wiring can cause excessive electrical usage or cause your blower motor to over heat and burn out.

Section III 3-1

**Connection to Central Unit
with Existing Blower Relay (continued)**

7. Locate the existing 24 volt transformer:
 - A. One 24 volt line (hot) should run from the transformer to the existing thermostat;
 1. Cut this wire and connect the wire going to the existing thermostat to terminal 2 of R-2 (new blower relay).
 2. Connect the wire running from the 24 volt transformer to terminal 1 of R-2 and also connect the red wire of the two conductor thermostat wire to terminal 1 of R-2.
 3. Connect the white wire of the two conductor thermostat wire to the red wire of the three conductor wire.
8. Locate the other 24 volt line (common) coming from the transformer:
 - A. Splice a white jumper wire to this wire.
 - B. Connect the other end of the white jumper wire to terminal 8 of R-2.
 - C. Also connect the white wire of the three conductor thermostat to terminal 8 of R-2.
 - D. Connect the green wire of the three conductor thermostat wire to terminal 7 of R-2.
 - E. Also connect a jumper wire from terminal 7 of R-2 to terminal 6 of R-2.
9. Locate the existing central unit blower relay (R-1):
 - A. Locate the wire running from the existing thermostat to the blower relay coil. Disconnect this wire from the existing blower relay coil and connect it to terminal 5 of the new blower relay R-2.
 - B. Connect a jumper wire from the existing blower relay coil (the point that you just disconnected) to terminal 4 of relay R-2.
10. If all connections are made properly and the water in the wood heater is hot, the unit should be ready for operation. NOTE: This is a general diagram. You may have to make various changes according to how your unit is wired.
 - A. Insure that the compressor on a heat pump or A/C unit does not run when the wood system is running.
 - B. Insure that the gas burner, oil burner, or electric elements do not come on when the wood system is running.
 - C. Insure that only one speed of the blower motor can be energized at one time. If more than one speed is energized at the same time, the blower motor will burn out.
 - D. Insure that the Volt Amp rating of the existing 24 volt transformer is not exceeded when the relays in the wood heating system are energized.

CONNECTION DIAGRAM

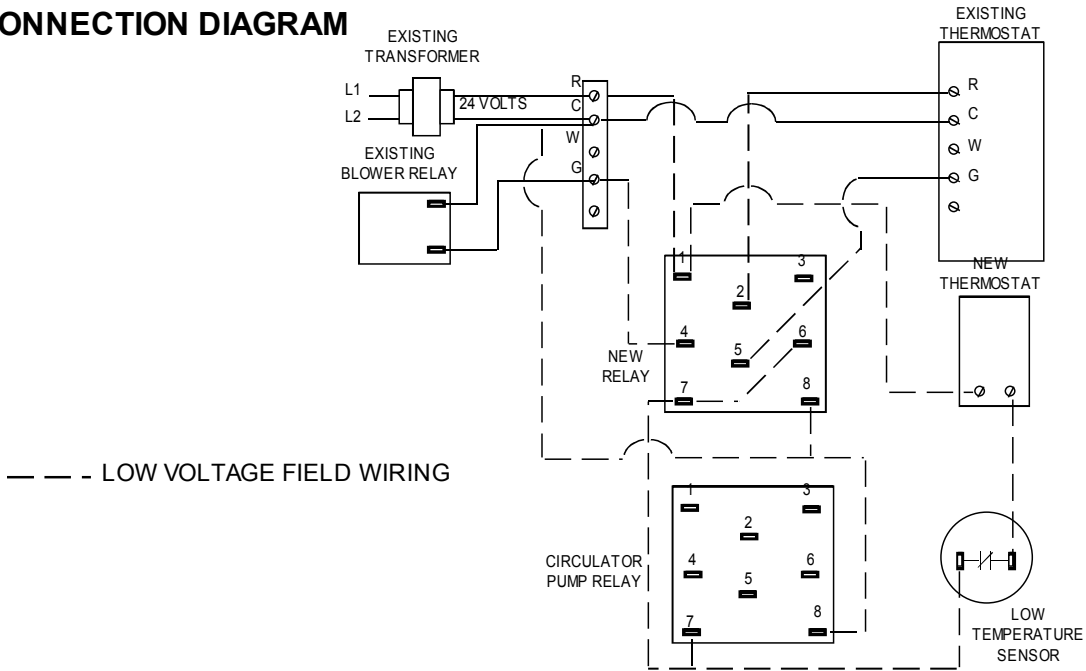

SCHEMATIC DIAGRAM

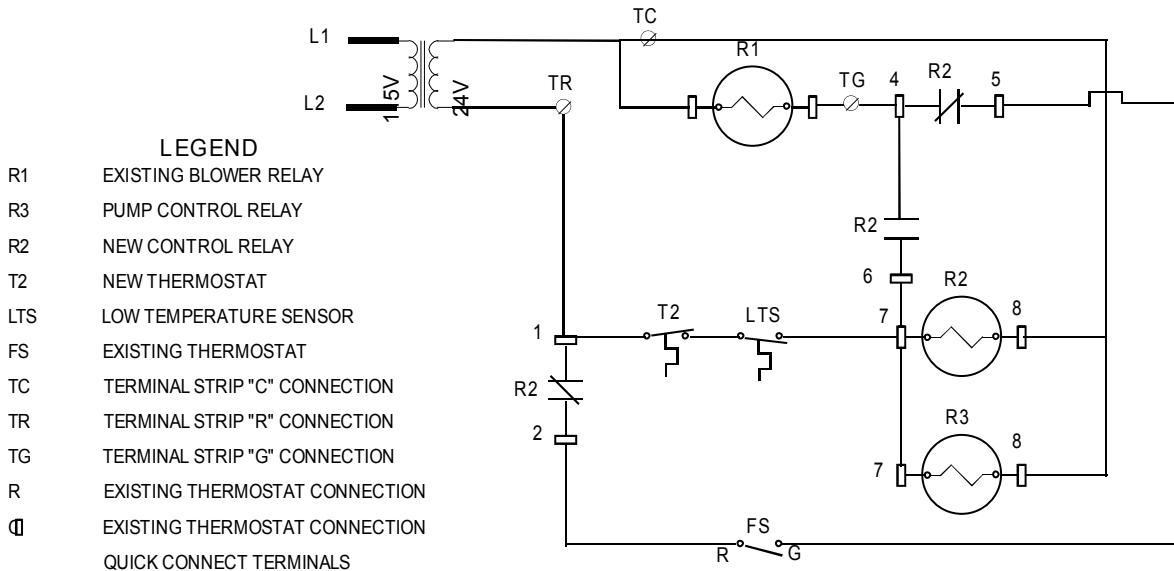

The following diagrams and pictures on this page and the following page show various methods of installing the heating coil in forced air system.

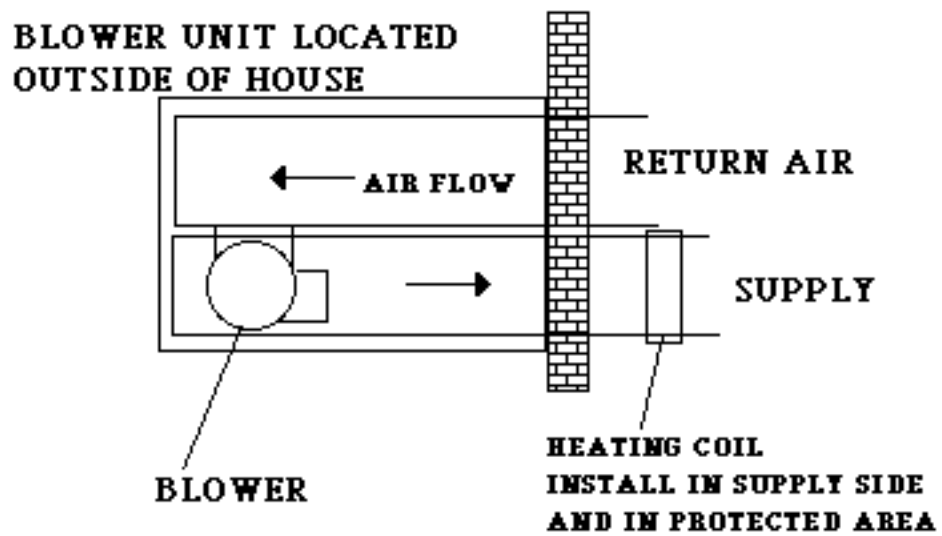

- 3) SUPPLY TO HEATING SYSTEM
- 4) HEATING SYSTEM RETURN

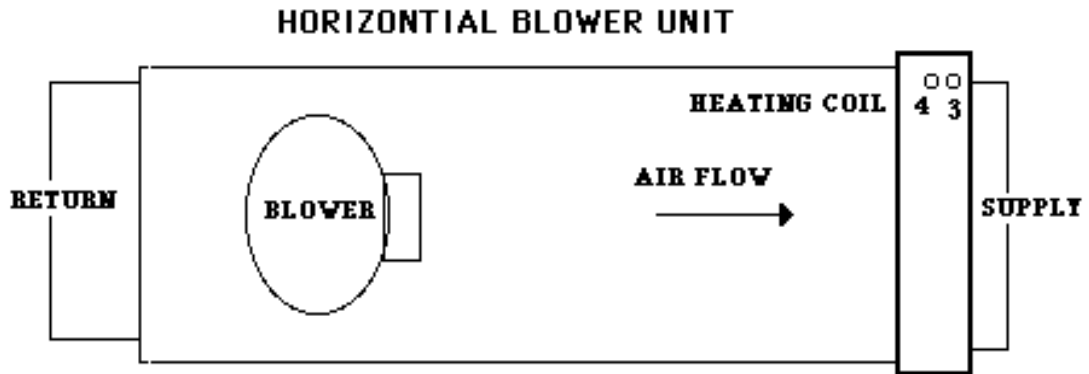
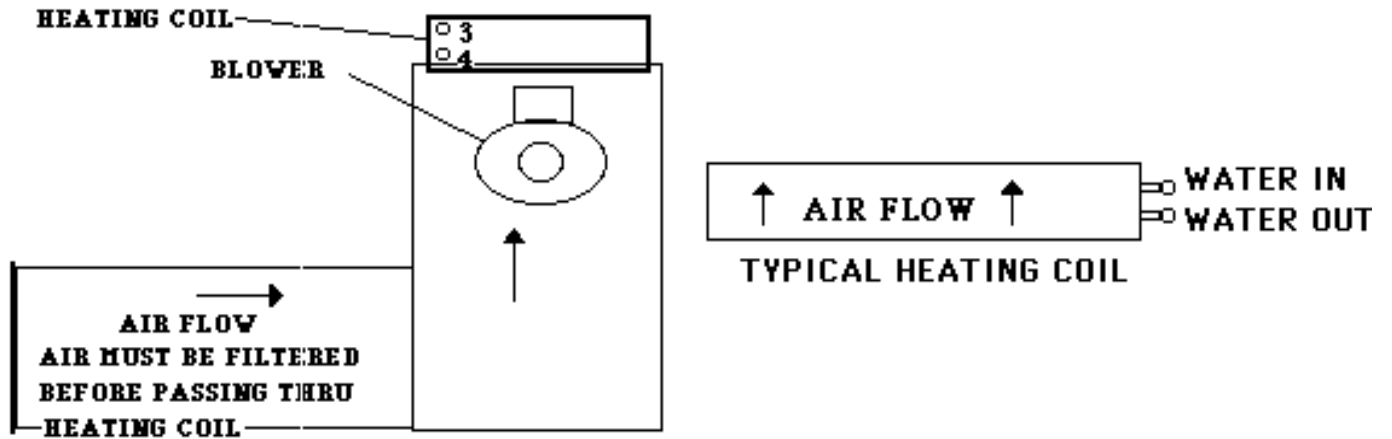

SECTION IV

CONNECTION TO HYDRONIC HEATING SYSTEMS (BASEBOARD)

4-1 Connection to Hydronic System with Existing 24 Volt Transformer

**ONE PUMP ON THE WOOD HEATER
USING HONEYWELL RELAY R8222D.
This unit must be wired by a qualified electrician in
accordance with the National Electrical Code.**

1. Run two conductor thermostat wire from the wood heater to the existing heating system in the house. This wire must be rated for underground use or be run inside a pvc pipe. The colors normally used are red and white.
2. At the heater, connect the white wire to terminal 8 of the water pump. (R-3)
3. Connect the red wire to terminal 7 of the water pump relay. (R-3)
4. In the house locate the existing pump relay. Connect the red wire of the two conductor thermostat wire to the coil of the pump relay, that is fed by the existing thermostat.
5. Connect the white wire of the two conductor thermostat wire to the coil of the pump relay on the side that is fed from the common side of the transformer.

Connection to Hydronic System
with Existing 24 Volt Transformer (continued)

CONNECTION DIAGRAM

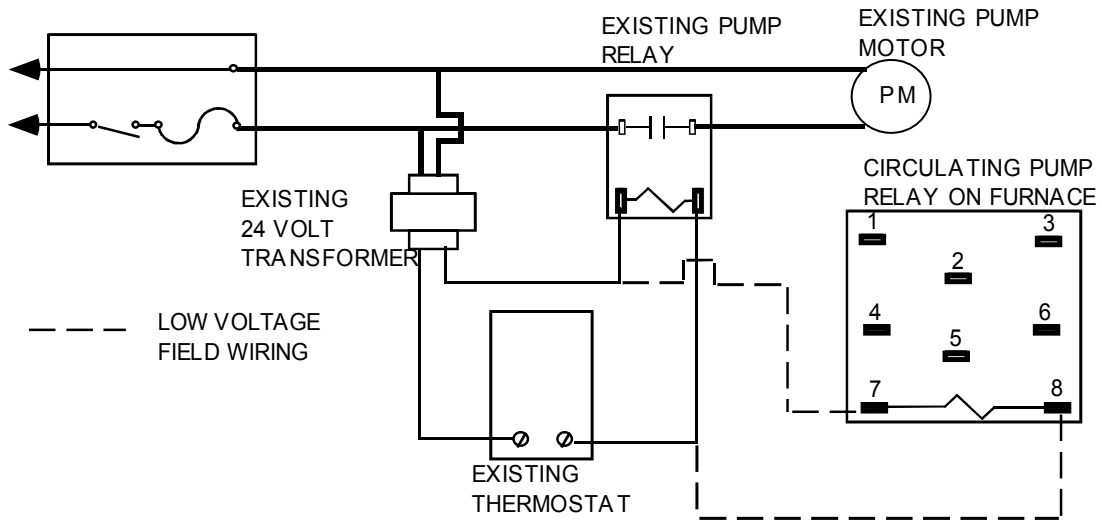

SCHEMATIC DIAGRAM

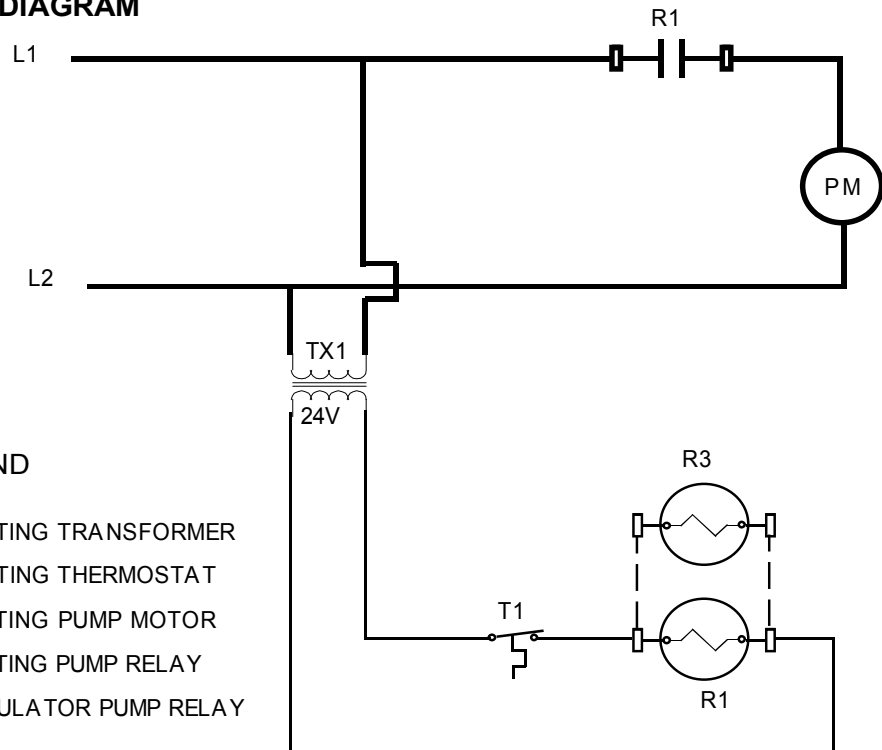

LEGEND

- TX1 EXISTING TRANSFORMER
- T1 EXISTING THERMOSTAT
- PM EXISTING PUMP MOTOR
- R1 EXISTING PUMP RELAY
- R3 CIRCULATOR PUMP RELAY

**Typical Diagram for Plumbing
Hydronic System**

Water Pipes must be designed for hot water service (ex. Copper, cpvc, or polybutylene.) Pipes should be installed in a 4" watertight pipe or some other type of insulating means to prevent heat loss from heater to heating system. Use only copper, brass, or stainless steel fittings. Do not use galvanized or black iron. Turn off the makeup water for the existing system. Manual filling of the wood heater or the electric fill option will supply makeup water for the wood heater and the existing hydronic. Close all automatic air vents on the existing system.

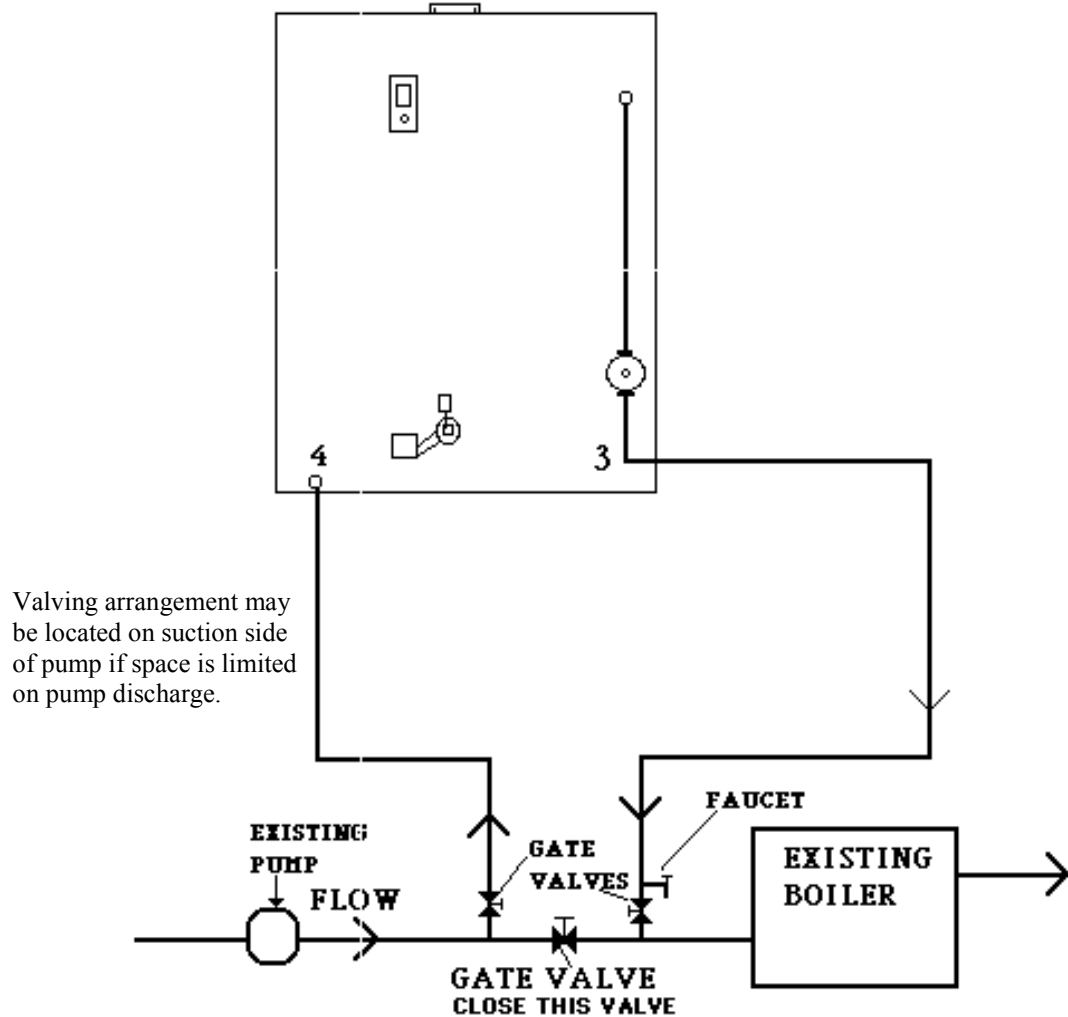

SECTION V

PLUMBING OPTIONS FOR DOMESTIC WATER

5-1 Plate Heat Exchanger for Domestic Hot Water

To add domestic hot water to the H25 model heater, a plate heat exchanger can be added into the recirculating pump circuit. This plate heat exchanger will provide preheated water to the domestic hot water. Mount a plate heat exchanger on the back of the heater and connect it as shown in the following picture. The Taco 008 pump will circulate heater water through the plate continuously. The cold water supply will be connected to the top right port on the plate heat exchanger. The bottom right port will feed into the cold side of your water heater.

Cold water feed will connect to the top port of the heat exchanger. The hot water will return from the bottom port of the heat exchanger to the cold water inlet of the water heater.

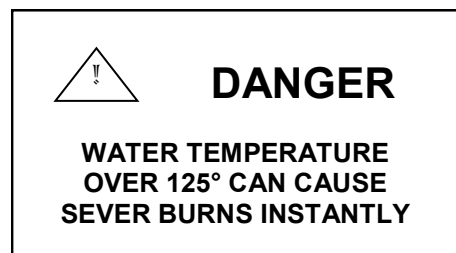
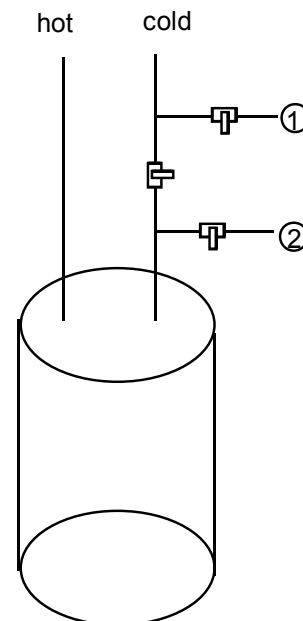
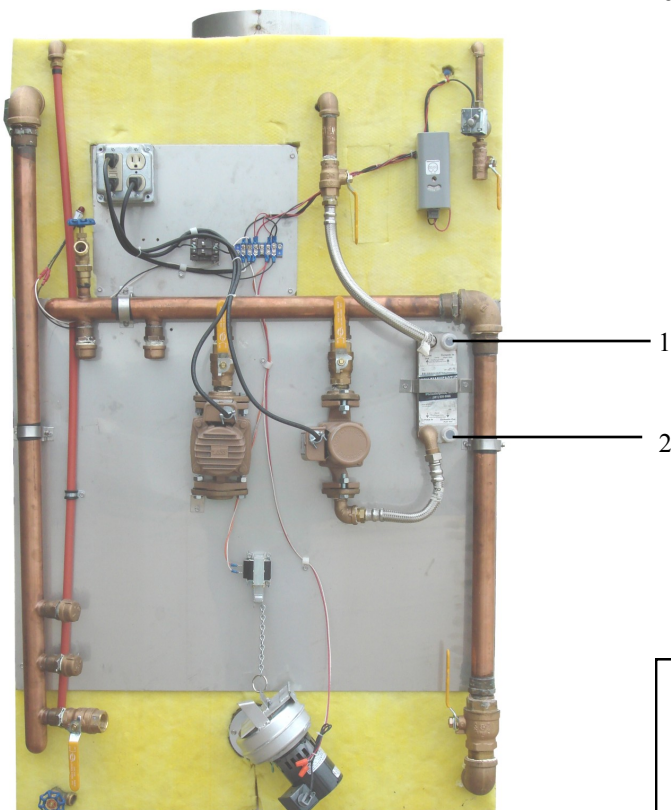

SECTION VI

HEATER OPERATION

6-1 Firing the Heater

Start the fire as you would in any other wood heater. Do not use petroleum products to start a fire. After you get an initial fire started, always stack the wood in the fire box straight. Do not cross the wood because this can cause the fire to go out. Any time you add wood, fill the fire box completely. The heater will burn only as much wood as is needed to keep the water hot.

CAUTION: ALWAYS OPEN THE BOTTOM DOOR BEFORE YOU OPEN THE TOP DOOR.

6-2 Water Temperature

In the back of the heater is a hot water aquastat. When power is supplied to the terminal strip the aquastat will send power to the damper system and draft blower as long as the heater water is below the setpoint of the aquastat. This setpoint is factory set at 170 to 180 degrees. If your heater does not operate correctly at these temperatures contact your authorized Hardy dealer for temperature adjustments.

6-3 Wood Usage

Never leave the doors open unattended because it will cause excessive wood consumption and could possibly damage the heater. If the heater is burning more wood than usual, check the seal around the front doors. If the seal is bad it will need replacing. Call your local Hardy dealer and order rope and silicone for the firebox or ash door. The fire in the heater must be out to seal the door. With door still mounted on the heater, scrape the old silicone out of the groove. Run a small bead of silicone in the groove of the door. Start installing the rope at the top edge of the wide groove (next to the hinges) running down the hinge side and continue around the door. Make sure the ends of the rope join together in the final corner, cut off any excess rope. Fill in the corners with silicone.

6-4 Moisture in the Firebox

On a new heater or the first time you start a fire each year, you will probably think you have a leak in the firebox. The firebox walls will sweat and water will run down the side. This can also happen if the water temperature drops below 100°F in the winter. This drop in temperature can be caused by improper burning due to stopped up grates. If you see moisture in the firebox, wait three days before you get alarmed. If it continues, check to see if you are burning green wood. Green wood will create a lot of moisture in the firebox, even to the extent that water can get as high as an inch or two in the ash pan.

If you still think you have a leak in your heater, remove all wood and ashes from the heater. Let it set a couple of days with doors closed. Then open the ash door. If you have a leak, water will run out of the ash box.

6-5 Improper Burning

If the fire is not burning properly, remove all of the ashes and wood from the heater. Check to see if the grates are stopped up. Check the air intake at the back of the heater to insure it is clear of ashes. Lift the damper lid to check for ashes. Check to see if the force air blower is running. If you have made these checks and the fire will not burn properly, remove the smoke stack and check for creosote buildup. Look down the smoke stack into the firebox to check for creosote buildup. Looking through the firebox door you will see an opening on the lower left and lower right corners just above the grates. These holes need to remain open for proper burn. The plate in the center is a loose plate that can be removed through the firebox door, cleaned, and reinstalled. These steps should correct the problem.

6-6 Ash Removal

Ashes must be removed before they build up to the level of the grates. Failure to keep the ash bin cleaned out will result in warped grates. The buildup of ashes in the firebox should be checked at least once a week. Allow the fire to burn down until the grates can be seen. This insures that all of the grates are clear. Failure to do this will cause your heating system to stop working and the grates to warp. If the grates warp slightly, they can be turned over and allowed to straighten out.

SECTION VII

SERVICE INFORMATION

7-1 Water Circulation System

LOW TEMPERATURE SENSOR, P/N H2000.36 – (WARNING: When working with electrical circuits, use caution to avoid electrical shock) – This sensor can be wired in the home heat thermostat circuit to prevent the pump on the heater from running when the water in the wood heater is not hot. The sensor has a set of contacts that close when the water rises to 110°F and open when the water drops to 90°F.

WATER PUMP RELAY, P/N H2000.52 - (WARNING: When working with electrical circuits, use caution to avoid electrical shock) – This is a Honeywell DPDT relay with a 24 volt coil. Terminal 4 and 6 (normally open contacts) are used to turn on the water pump. Control voltage (24 volts) connected at terminals 7 and 8 routed through a home thermostat energizes the relay.

WATER PUMP FOR HEATING SYSTEM, Taco 009 pump P/N H502.00 - (WARNING: When working with electrical circuits, use caution to avoid electrical shock) – with bronze body. If the pump will not run, first unplug the power cord then check the water pump relay. The relay can be bypassed by disconnecting the wire from terminal 6 and then connecting to terminal 5 (terminals 4 to 5 is normally closed) remove the thermostat wire from terminal 8 and plug the power cord back in. This should supply 115 vac directly to the pump. If the pump will still not run, unplug the power cord. Remove the four bolts holding the pump to the pump housing. Remove the cartridge from the pump. Spin the impeller by hand to see if the cartridge is locked up. If the impeller will not spin, replace the cartridge. If the impeller will spin, it may have been temporarily stuck (reassemble and try again) or the problem is the electrical winding or capacitor. Use an ohm meter to check the winding and capacitor. If the capacitor is defective, replace it. If the electrical winding is defective, replace the complete pump.

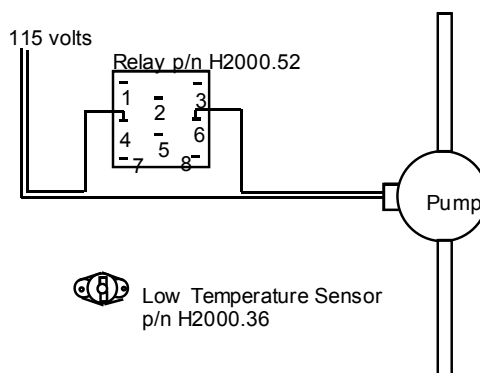

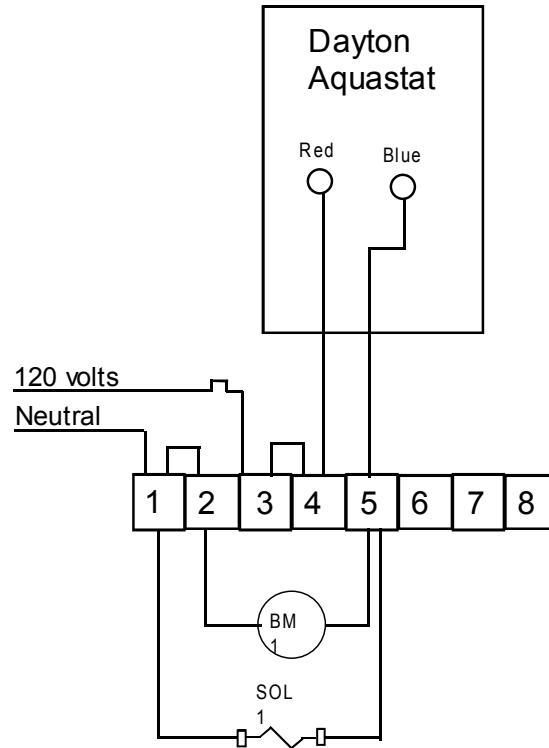

DAMPER THERMOSTAT, Dayton - (WARNING: When working with electrical circuits, use caution to avoid electrical shock) – This thermostat has a probe that is in a well in the water tank of the wood heater. It has a set of contacts that open on a temperature rise and close on a temperature fall. This thermostat is normally set at 170°F to 180°F. It controls the damper solenoid and the forced air draft. If the damper solenoid and forced air draft will not operate, place a jumper wire across the terminal strip from #4 to #5. If they operate when the correct terminals are jumpered out, and the temperature of the water in the heater is below the set point on the thermostat, the thermostat is defective. Do not leave the jumpers across the terminal strip because the heater will overheat.

DAMPER SOLENOID, P/N H 2001.05 - (WARNING: When working with electrical circuits, use caution to avoid electrical shock) – This solenoid lifts the cover off the intake to the forced air draft blower. The solenoid is controlled by the damper thermostat. It should lift the cover when the forced air blower comes on and drop the cover.

FORCED AIR DRAFT BLOWER, P/N H2002.28 - (WARNING: When working with electrical circuits, use caution to avoid electrical shock) – This blower supplies air to the fire box when the damper thermostat calls for heat. If the blower wheel or the intake to the blower is clogged, the blower will not deliver the proper amount of air to the fire. The blower can be disassembled and cleaned. Be sure to seal the blower motor back to the blower housing if the blower is disassembled. The motor should be oiled at the beginning of each heating season. When the heater is not in use, the power cord for the blower should be unplugged.

**Each year before the heating season begins,
you should check your heater to insure
that everything is ready for the heating season.**

1. **WATER QUALITY** – The Hardy Heater is designed not to lose heater water through evaporation. At times during the year, accidental overheating can occur, and the water will evaporate. The evaporation causes a concentration of chlorides (salts) and other minerals. To protect your heater from this build up of chlorides (salts) and other minerals, we recommend to drain your heater each year at time of startup for the heating season and refill with rain water or bottled water with a chloride concentration of less than 15 parts per million. This will add to the life of your stainless steel tank.

2. **DAMPER AND DRAFT SYSTEM** – When you plug in the power cord, the damper solenoid should have opened the draft lid on the draft blower. The forced air draft blower should also have come on. If both of these components are working correctly, unplug the power cord. Open the clean out lid beside the draft blower and check for any build up of ash, tar, or any other material that could restrict the amount of combustion air entering the heater. Check the seal on the clean out lid to assure a good air tight seal is still established. Lift the damper lid on the draft blower and inspect the blower wheel for any build up of lint, dust, creosote, or any other substance that could effect the performance of the draft blower. Spray the damper lid hinge, and the damper solenoid plunger with WD-40, or its equivalent. Oil the draft blower motor with electric motor oil, or 10 weight non detergent motor oil. Do not use WD-40, or machine oil. Check the grates inside the heater to see if there is any ash build up or if the grates are warped. If a grate does warp, lift that grate up and turn it over. Also at this time check the smoke stack for blockage.

3. **WATER PUMP** – Unplug the power cord going to the water pump. Close the valve above the water pump and the return water valve at the bottom of the heater. Remove the pump motor from the pump housing by removing the four bolts in the pump housing. Remove the impeller cartridge assembly from the pump housing. Check the impeller to determine if it is free by spinning the impeller in the cartridge. Check the pump housing for rust or any other build up that could impede the flow of water. Reassemble the water pump, making sure the “O” ring in the cartridge is seated right. Once the pump is reinstalled, open the water valve above the pump and the return valve.

Section VII

7-5

Trouble Shooting Guide H25

COMPLAINT	AREA OF TROUBLE	POSSIBLE CAUSES	CORRECTIVE ACTION
<p>NO HEAT</p> <p>Main power supply and ground fault interrupter receptacle "OK"</p> <p>Water temperature is "HOT"</p>	Pump Performance	Unplug pump and bypass relay by tying relay wires #4 and #6 together. Plug pump back in.	
	Pump does not run	<ol style="list-style-type: none"> 1 Defective pump cartridge 2 Defective pump capacitor 3 Defective pump motor winding 	<ol style="list-style-type: none"> 1 Unplug pump. Remove pump. Pull cartridge from pump and spin impeller by hand. If impeller will not spin, replace cartridge. 2 Use Ohmmeter. When the meter is connected to the capacitor, the needle should jump to "0" ohms and slowly drift back to infinity. Replace if defective. 3 Disconnect the wires connected to the motor terminals to test the motor independent of electrical connections. Check for ground and continuity with ohmmeter The insulator of the windings should show no breakage. If it does, replace pump
	Pump does run	<ol style="list-style-type: none"> 1 Defective 24 volt transformer 2 Defective wall thermostat (heater) 3 Defective low temperature sensor 4 Defective pump relay 	<ol style="list-style-type: none"> 1 Located at existing central unit. If 115/120 volts is being supplied to primary side check for 24 volts on secondary. If 24 volts not present, replace transformer. 2 Located inside home. Remove cover. Check for 24 volts. Level the mounting base. Blow dust from sensing bimetal. Adjust heat anticipator. See owners manual connection instructions. 3 Remove wires on sensor and connect to each other to bypass. If pump runs replace low temperature sensor. 4 Check relay terminals #7 & #8 for 24 volts. If 24 volts is present, use ohmmeter to check contacts. Connect ohmmeter to terminals #4 & #6. If no reading replace relay.

Section VII

7-5

Trouble Shooting Guide H25

COMPLAINT	AREA OF TROUBLE	POSSIBLE CAUSES	CORRECTIVE ACTION
<p>NO HEAT</p> <p>Main power supply and ground fault interrupter receptacle "OK"</p> <p>Water temperature is "COLD"</p>	Aquastat	1 Defective Aquastat	1 Place a jumper wire across terminal #4 & #5 on the terminal strip. If blower and Damper solenoid operates, replace aquastat
	Damper Solenoid	1 Defective damper solenoid	1 When bypassing aquastat if solenoid does not lift the lid off the intake to the forced air draft blower, replace the solenoid.
	Forced Air Draft Blower Motor	<p>Defective blower motor</p> <p>1 Defective electrical wiring</p> <p>2 Air passage stoppage</p> <p>3 Blower wheel clogged</p>	<p>1 Make sure all connections are secure.</p> <p>2 Clear air passages in cleanout and damper blower outlets</p> <p>3 Clear blower wheel of any lint, ashes or creosote build up.</p>
	Ash Bin	1 Ash buildup in ash bin	1 Clean out ash bin. Ash bin should be cleaned out each week. Ash build up on grates can cause grates to warp. If grates warp they can be turned over and allowed to straighten.
	Heater Stack	1 Ash and Creosote Buildup	1 Clean heater stack of any ash and creosote build up.
Excessive Wood Usage	Firebox	<p>1 Open</p> <p>2 Defective door seals</p> <p>3 Damper lid not closing properly</p> <p>4 T & P valve leaking</p>	<p>1 Close all doors and make sure they are securely fastened.</p> <p>2 If the seal is bad it will need replacing. Call your local Hardy dealer to request rope and silicone. See owners manual, (heater operation section) for replacing door seals.</p> <p>3 Remove any obstructions causing lid not to close properly.</p> <p>4 If leaking, replace.</p>

Section VII 7-5 Trouble Shooting Guide H25

COMPLAINT	AREA OF TROUBLE	POSSIBLE CAUSES	CORRECTIVE ACTION
Improper Burning Remove all the ashes and wood	Grates	1 Grates stopped up	1 Clear grates of ash buildup. If grates are warped, turn them over and allow to straighten.
	Air intake	1 Air intake stopped up	1 Clean air intake at back of heater of any obstructions.
	Damper Chamber	1 Damper chamber stopped up	1 Lift damper lid and check for obstructions.
	Forced Air Blower	1 Forced air blower not running	1 If not running see <u>No Heat</u> section in this guide
	Smoke Stack	1 Smoke stack stopped up	1 Remove smoke stack and check for creosote build up.
	Baffle	1 Baffle blocked	1 Clean out fire box and check openings to baffle plate
	Fire	1 Fire goes out	1 If fire goes completely out when damper is closed, check the holes in the damper lid for obstructions, clean out.
Moisture In Fire Box	Firebox	1 Yearly startup 2 Green Wood	1 The firebox walls will sweat and water will run down the sides. This should clear up in a few days. 2 Green wood will create excess moisture.

THIS PAGE INTENTIONALLY LEFT BLANK

25 YEAR LIMITED WARRANTY

Hardy Manufacturing Co., Inc. (HARDY), hereby warrants that HARDY products shall be free from defect in material and workmanship under normal use according to the provisions and limitations herein set forth. HARDY warrants the Fire Box/Water Tank for five (5) years from the date of purchase by the original purchaser and pro rata thereafter according to the following schedule:

- * If the defect occurs to the tank during the sixth year, customer pays 20% of repair or replacement.
- * If the defect occurs to the tank during the seventh year, customer pays 35% of repair or replacement.
- * If the defect occurs to the tank during the eighth year, customer pays 50% of repair or replacement.
- * If the defect occurs to the tank during ninth year, customer pays 65% of repair or replacement.
- * If the defect occurs to the tank during the tenth year, customer pays 80% of repair or replacement.
- * If the defect occurs to the tank during the eleventh through twenty-fifth year, customer pays 85% of repair or replacement.

HARDY warrants catalytic combusters, if standard with furnace, for a period of three (3) years from the date of purchase by the purchaser.

HARDY warrants electrical and plumbing components for a period of one (1) year from date of purchase by the purchaser.

HARDY warrants all other Hardy Manufacturing products for a period of one (1) year from the date of purchase by the purchaser.

Limitations:

The obligation of HARDY for a breach of warranty shall be limited to products manufactured by HARDY 1) that are installed, operated and maintained according to HARDY's instructions, including Best Burn Practices, furnished and/or available to the purchaser upon request; 2) that are installed according to all other applicable Federal, State and local codes or regulations; and 3) that the purchaser substantiates products were defective in material and workmanship notwithstanding that they were properly installed and correctly maintained as set forth above and were not abused or misused.

The obligation of HARDY shall be limited to repairing or replacing the defective product, at the option of HARDY. HARDY shall not be responsible for any labor or cost removal or reinstallation of its products and shall not be liable for transportation costs to and from its plant in Philadelphia, Mississippi.

Use of parts for modification or repair of the product or any component part thereof not authorized or manufactured by HARDY specifically for such product shall void this warranty. Use of water in water tank that exceeds 45 ppm chloride content shall void warranty.

This warranty shall not apply to any damage to or defect in any of HARDY's products that is directly or indirectly caused by 1) force majeure, Act of God or other accident not related to an inherent product defect, or 2) abuse, misuse or neglect of such product, including any damage caused by improper assembly, installation, adjustment, service, maintenance, or faulty instruction of the purchaser.

Other than as expressly set forth herein above, HARDY makes no other warranty, express or implied, with respect to any of HARDY's products including but not limited to any warranty of merchantability or fitness for a particular purpose.

And in no event shall HARDY be responsible for any incidental or consequential damages of any nature suffered by purchaser or any other person of entity caused in whole or in part by any defect in any HARDY's products. Any person or entity to whom this warranty extends and who claims breach of warranty against HARDY must bring suit thereon within one year from the date of occurrence of such breach of warranty or by forever barred from any and all legal or other remedies for such breach of warranty.

HARDY is not responsible for and hereby disclaims any undertaking, representation or warranty made by any dealer, distributor or other person that is inconsistent with or in any way, more expansive than the provisions of this limited warranty. The return of warranty registration, with chloride test strip, to manufacturer is required to secure warranty validation.

This warranty grants specific legal rights and shall be read in conformity with applicable state laws. In some jurisdictions, the applicable law mandates warranty provisions that provide greater legal rights than those provided for herein. In such case, this limited warranty shall be read to include such mandated provisions and any provision herein that is prohibited or unenforceable in any such jurisdiction shall, as to such jurisdiction, be ineffective to the extent of such prohibition or unenforceable without invalidating the remaining provisions and without affecting the validity or enforceability of such provision in any other jurisdiction(s).

Effective Date: 1-1-2008 • Revision Date: 1-1-2008

Section I 1-2

Heater Component Parts (Model H25)

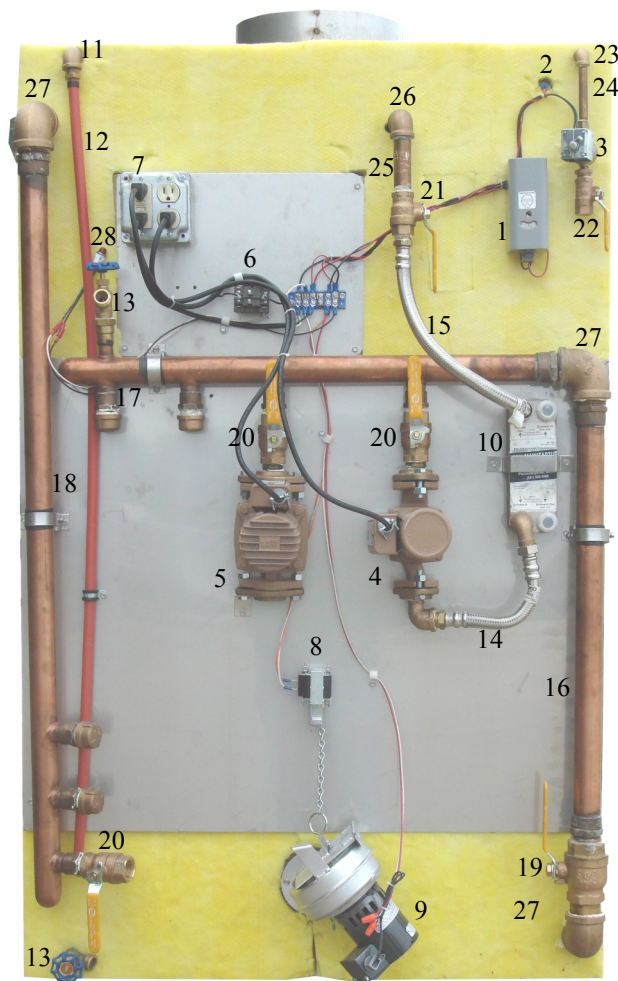

<u>Legend</u>	<u>Part No.</u>	<u>Description</u>
1)	2000.16	Aquastat
2)	1100.28	Low Water Switch
3)	1100.00	Water Solenoid
4)	508.09	Taco 008
5)	502.08	Taco 009
6)	2000.52	Relay
7)	2004.00	GFCI
8)	2001.05	Damper Solenoid
9)	2002.30	130 CFM Blower
10)	300.02	Plate Exchanger
11)	600.10	1/2" Brass elbow
12)	810.00	1/2" Overflow pipe
13)	607.42	3/4" Male Boiler Drain Valve
14)	700.05	3/4" x 10" SS Flex Line
15)	700.18	3/4" x 18" SS Flex Line
16)	900.80	1 1/2" Copper Supply
17)	900.85	1 1/2" Copper Pump Supply
18)	900.90	1 1/2" Copper Return
19)	607.47	1 1/2" Brase Ball Valve
20)	607.45	1" Brass Ball Valve
21)	607.12	3/4" Brass Ball Valve
22)	607.00	1/2" Brass Ball Valve
23)	600.05	1/4" Brass Elbow
24)	603.04	1/4" X 4" Brass Nipple
25)	603.28	3/4" X 4" Brass Nipple
26)	600.30	3/4" Brass Elbow
27)	600.48	1 1/2" Brass Elbow
28)	1100.30	Low Water Indicator Light