



MODEL H0580 PNEUMATIC GREASE GUN INSTRUCTION SHEET

⚠ WARNING



EYE INJURY HAZARD!
Always wear safety glasses during use to prevent serious personal injury.

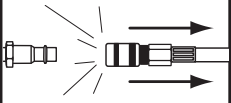

INJURY HAZARD!
When servicing, always disconnect tool from air to prevent unexpected operation.



**150 PSI
MAX AIR PRESSURE!**
Exceeding this PSI may result in injury/tool damage.

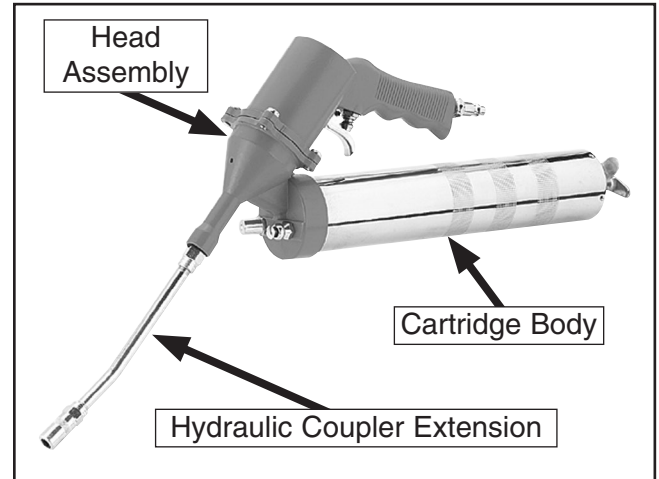

Figure 1. Model H0580.

Specifications

Air Inlet 1/4" NPT
Average Air Consumption 4 CFM
Operating Pressure 90 PSI
Capacity 14 oz., (400cc bulk grease)
Weight 3.2 lbs. (Empty)

Inventory (Figure 1)

Qty

- A. Grease Gun 1
- B. Hydraulic Coupler with Extension 1

Operation

To improve tool lifespan, use a filter/lubricator/regulator setup, as shown in **Figure 2**.

Otherwise, lubricate multiple times daily with 2–3 drops of pneumatic tool oil. Place the oil directly into the air fitting, as shown in **Figure 3**.

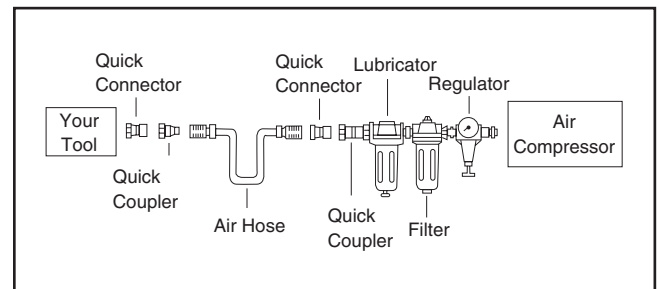

Figure 2. Installing a filter/lubricator/regulator to improve the lifespan of your tool.

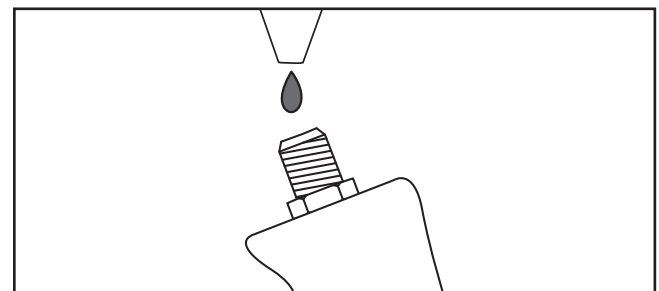

Figure 3. Lubricating directly into air fitting.

If you need help with your new pneumatic tool, call our Tech Support at: (570) 546-9663.

COPYRIGHT © MAY, 2008 BY GRIZZLY INDUSTRIAL, INC.

WARNING: NO PORTION OF THIS MANUAL MAY BE REPRODUCED IN ANY SHAPE OR FORM WITHOUT THE WRITTEN APPROVAL OF GRIZZLY INDUSTRIAL, INC.

#JM10671 PRINTED IN TAIWAN

To operate your H0580 grease gun:

1. Connect the grease gun to compressed air regulated at a pressure between 30 and 100 PSI.

Note: For quick connection type air fittings, a 1/4" NPT female plug is needed (sold separately.)

2. Wipe all fittings clean with a shop towel.
3. Pull grease gun trigger once or twice to purge the coupler of any contaminants or old grease.
4. Push the grease gun coupler onto the fitting to be lubricated.

Note: It is easier to attach the coupler to the fitting at a slight angle. Be sure to center the coupler over the fitting when applying grease.

5. Pull the trigger to inject grease.
6. After lubricating, turn the coupler at a slight angle to release it from the fitting.

NOTICE

Some mechanical systems may only require a small amount of grease, while others require much more. Understand the lubrication requirements of the part you are lubricating. Failure to follow this instruction can damage seals or under-lubricate parts, causing costly damage.

Installing a Grease Cartridge

To install a grease cartridge, the follower assembly must be fully withdrawn, allowing room for the new cartridge.

To properly load a new grease cartridge:

1. DISCONNECT THE TOOL FROM THE AIR SUPPLY!

2. Pull the follower rod back until it is fully extended; the locking tab will automatically hold it in place (**Figure 4**).

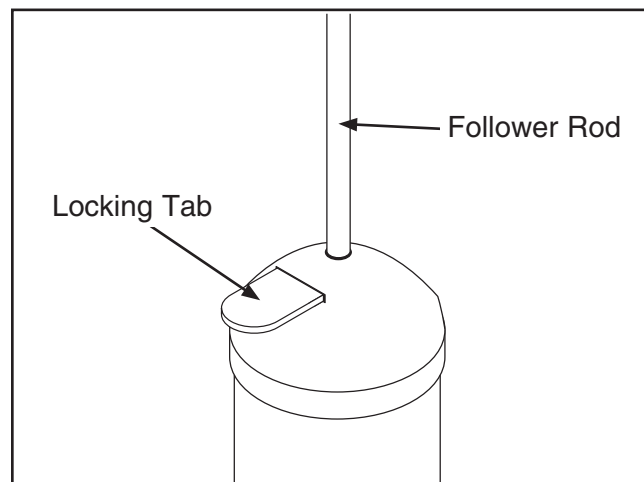

Figure 4. The follower rod and locking tab

3. Remove the head assembly (**Figure 1**) from the cartridge tube.
4. If an empty grease cartridge is in the gun, remove it by carefully pushing the locking tab and allowing the follower rod to slowly move into the cartridge tube.
5. After ejecting the used grease cartridge, pull the follower rod back until it is fully extended, and allow the locking tab to hold it in place (**Figure 4**).
6. Insert the new grease cartridge into the cartridge tube according to the instructions on the grease cartridge.
7. Securely fasten the head assembly to the cartridge tube and release the follower rod by pushing on the locking tab.
8. Push the follower rod in as far as possible.



Filling from a Bulk Grease Container

1. DISCONNECT THE TOOL FROM THE AIR SUPPLY!
2. Pull the follower rod back until it is fully extended, the locking tab will automatically hold it in place (**Figure 4**).
3. Remove the head assembly from the cartridge tube.
4. Remove any grease from the cartridge tube by pushing the locking tab and carefully releasing the follower rod, allowing it to slowly move into the cartridge tube.
5. Without introducing bubbles, pack grease into the head cavity and plunger assembly until they are full (**Figure 5**).

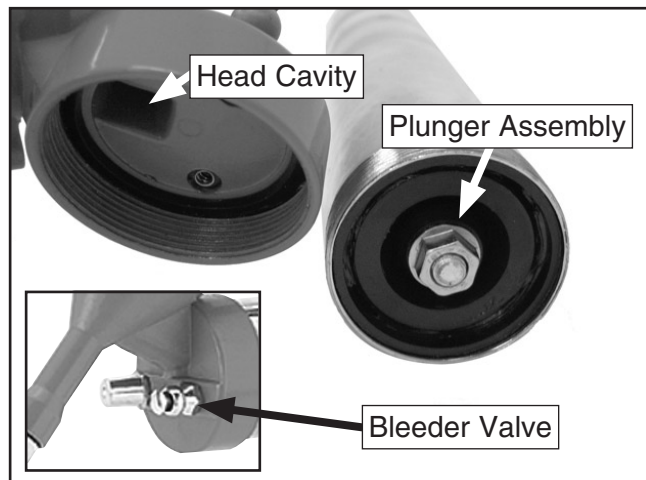

Figure 5. Grease locations and bleeder valve.

6. Insert the open end of the cartridge tube into the barrel or drum of the bulk grease to be added.
7. Slowly pull the follower handle back while pushing the cartridge tube deeper into the grease. This method will help prevent drawing in air bubbles.
8. When the follower rod is fully extended, allow the locking tab to hold it in place (**Figure 4**).
9. Securely fasten the head assembly to the cartridge tube and release the follower rod by pushing on the locking tab.
10. Push the follower rod in as far as possible.

Filling With a Bulk Grease Pump

1. DISCONNECT THE TOOL FROM THE AIR SUPPLY!
2. Pull the follower rod back until it is fully extended, the locking tab will automatically hold it in place.
3. Insert the grease gun grease inlet (part # 11) into the proper fitting on the pump operated bulk grease container.
4. Operate the bulk grease pump to fill the grease gun container.
5. Remove the grease gun from the pump and release the locking tab.
6. Push the follower rod in as far as possible.

Bleeding Air Pockets

If at any time you experience problems with the grease gun dispensing grease, especially after refilling, air is likely trapped in the head assembly.

To bleed air pockets from the grease gun:

1. DISCONNECT THE TOOL FROM THE AIR SUPPLY!
2. Pull back on the follower rod until it is fully extended (**Figure 4**).
3. Release the follower rod by pushing on the locking tab.
4. Push the follower rod all the way forward while holding down the bleeder valve shown in **Figure 5**, until the air is expelled from the gun.
5. Reconnect the grease gun to the air supply, and pull the trigger several times to release any air in the head assembly and verify the grease gun works correctly.

Note: *If the grease gun does not dispense grease correctly, repeat this procedure as many times as necessary.*



H0580 Parts Breakdown and List

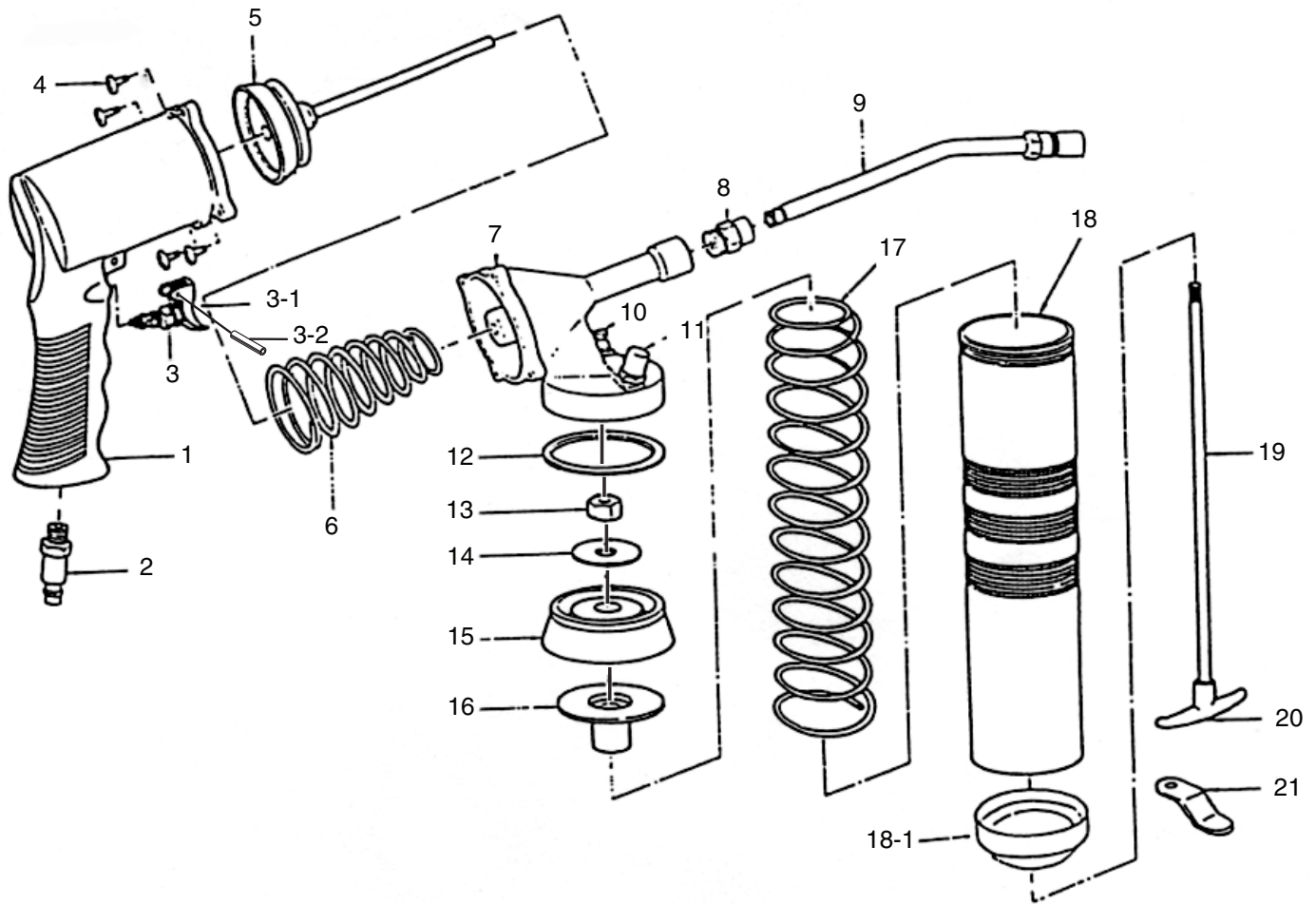

| REF | PART # | DESCRIPTION |
|-----|-------------|-----------------------------|
| 1 | PH0580001 | GREASE GUN BODY |
| 2 | PH0580002 | 1/4" NPT AIR INLET |
| 3 | PH0580003 | SWITCH |
| 3-1 | PH0580003-1 | TRIGGER AND PIN |
| 3-2 | PRP37M | ROLL PIN 3 X 14 |
| 4 | PH0580004 | SPECIAL BODY SCREW |
| 5 | PH0580005 | AIR PLUNGER |
| 6 | PH0580006 | SHORT SPRING |
| 7 | PH0580007 | HEAD |
| 8 | PH0580008 | ADAPTER |
| 9 | PH0580009 | HYDRAULIC COUPLER EXTENSION |
| 10 | PH0580010 | BLEEDER VALVE |

| REF | PART # | DESCRIPTION |
|------|-------------|-----------------|
| 11 | PH0580011 | GREASE INLET |
| 12 | PH0580012 | GASKET |
| 13 | PH0580013 | PLUNGER NUT |
| 14 | PH0580014 | PLUNGER WASHER |
| 15 | PH0580015 | PLUNGER |
| 16 | PH0580016 | BACKLASH GASKET |
| 17 | PH0580017 | LONG SPRING KIT |
| 18 | PH0580018 | CARTRIDGE TUBE |
| 18-1 | PH0580018-1 | BOTTOM CAP |
| 19 | PH0580019 | FOLLOWER ROD |
| 20 | PH0580020 | ROD HANDLE |
| 21 | PH0580021 | LOCKING TAB |