

bühler

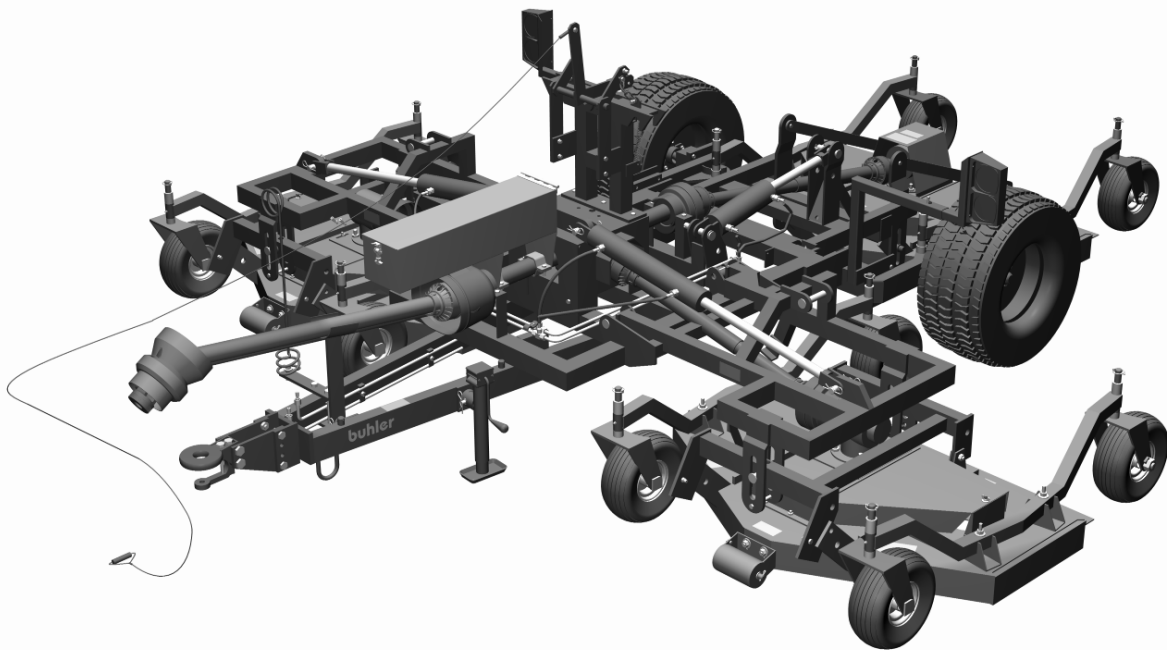

Triplex Finishing Mower

Operator's and Parts Manual
FK333

2007

TABLE OF CONTENTS

DESCRIPTION	PAGE NUMBER
OPERATION & ASSEMBLY	
Warranty.....	1
Operating Safety	2
Transport Safety.....	3
Maintenance Safety	3
Safety Signs	4
Triplex Assembly Instructions	7-12
Triplex Harness Routing	13-14
Maintenance.....	15-16
Bolt Torque.....	17
Triplex Hitch Assembly Drawing	18
4' Main Frame Drawing & Parts List	19-21
4' Side Wing Assembly Drawing and Parts List	22-23
4' Rear Wing Assembly Drawing & Parts List.....	24-25
4' Latch Assembly Drawing & Parts List.....	26-27
4' Hydraulic Assembly Drawing & Parts List.....	28-29
4' Side Mower Deck Drawing & Parts List.....	30-32
4' Center Mower Deck Drawing & Parts List.....	33-35
4' PTO Assembly Drawing & Parts List.....	36
5', 6' & 7' Main Frame Drawing & Parts List	37-39
5', 6' & 7' Side Wing Assembly Drawing & Parts List	40-41
5', 6' & 7' Rear Wing Assembly Drawing & Parts List.....	42-43
5', 6' & 7' Latch Assembly Drawing & Parts List.....	44-45
5', 6' & 7' Hydraulic Assembly Drawing & Parts List.....	46-47
5', 6' & 7' Side Mower Deck Drawing & Parts List	48-50
5', 6' & 7' Center Mower Deck Drawing & Parts List.....	51-53
5', 6' & 7' PTO Assembly Drawing & Parts List	54
Spindle Assembly Drawing & Parts List.....	55-56
Finishing Mower Gearbox Drawing & Parts List	57-58
Triplex Gearbox Drawing and Parts List	59
PTO Shaft Drawings, Parts Lists	60-67
Cylinder Assemblies.....	68-69
Shipping Bundles	70-71
MAINTENANCE	
PTO Shafts	72-75
Mower Deck Wheel Bearings Drawing & Parts List.....	76
Triplex Wheel Bearings Drawing & Parts List.....	77
Blade Height Adjustment Drawing & Parts List.....	78
Triplex Splitter Gearbox & Mower Gearbox Lubrication	79
Brass Bushing Replacement & Lubrication on Wings Drawing Drawing & Parts List.....	80
Triplex Frame Wing & Mower Spindle Lubrication.....	81
Spindle Replacement Drawing & Parts List.....	82-84
Mower Deck Belt Adjustment Drawing & Parts List.....	85-86
UHMW Bushing Replacement Drawing & Parts List	87-88
Blade Replacement Drawing & Parts List.....	89-90
Service Notes and Maintenance Check List.....	91

WARRANTY POLICY

Buhler Manufacturing products are warranted for a period of twelve (12) months (90 days for commercial application) from original date of purchase, by original purchaser, to be free from defects in material and workmanship under correct, normal agricultural use and proper applications.

Buhler Manufacturing's obligations under this warranty shall be limited to the repair or exchange, at Buhler Manufacturing's option, of any Buhler Manufacturing product or part which proves to be defective as provided. Buhler Manufacturing reserves the right to either inspect the product at the buyer's location or have it returned to the factory for inspection.

The above warranty does not extend to goods damaged or subject to accident, abuse or misuse after shipment from Buhler Manufacturing's factory, nor to goods altered or repaired by anyone other than an authorized Buhler Manufacturing representative.

Buhler Manufacturing makes no Express Warranties other than those, which are specifically described. Any description of goods, including any references and specifications in catalogues, circulars and other written material published, is for the sole purpose of identifying goods and shall conform to such descriptions. Any sample or model is for illustrative purposes only and does not create an Express Warranty that the goods conform to sample or model shown.

The purchaser is solely responsible for determining suitability of goods sold. This warranty is expressly in lieu of all other warranties expressed or implied. Buhler Manufacturing will in no event be liable for any incidental or consequential damages whatsoever. Nor for any sum in excess of the price received for the goods for which liability is claimed.

WARRANTY CLAIMS:

Warranty requests must be prepared on Buhler Manufacturing Warranty Claim Forms with all requested information properly completed. Warranty Claims must be submitted within a thirty (30) day period from date of failure repair.

WARRANTY LABOR:

Any labor subject to warranty **must** be authorized by Buhler Manufacturing. The labor rate for replacing defective parts, where applicable, will be credited at 100% of the dealer's posted shop rate. Defective parts will receive an extra 10% discount to assist with freight or other incidental costs.

GOVERNMENT LEGISLATION:

Warranty terms and conditions are subject to Provincial or State legislation.

IMPORTANT FACTS:

Buckets and Bucket Tines Carry No Warranty
Bent Spears Carry No Warranty
Snowblower Fan Shafts Carry No Warranty
Mower Blades Carry No Warranty
Portable Auger Parts Have Two (2) Year Warranty
Loader Parts Have Two (2) Year Warranty

IMPORTANT NOTE: This warranty does not apply to rentals

SAFETY INSTRUCTIONS

Do not attempt to operate the mower until you have read the operator's manual and all the safety signs on the mower.

⚠ ALERT The words danger or caution on the safety signs indicate a hazard or unsafe practice which could result in injury or death if proper precautions are not taken. Do not attempt any unauthorized modifications to the mower as this could affect the function or the safety of the mower.

OPERATING SAFETY

1. Keep all safety signs clean and legible at all times. Replace damaged or missing safety signs.
2. Ensure all shields are in place and in good condition before operating.
3. Ensure everyone is clear of the area before operating.
4. Never start or operate the mower except from the operator's station on the power unit.
5. Do not permit riders.
6. Stop engine, set brake, remove key and wait for all moving parts to stop before servicing, adjusting, repairing and unplugging.
7. Never operate over 540 rpm PTO speed.
8. Inspect and clean the cutting area before cutting.
9. Never operate the mower in the raised position.
10. Do not use loose fitting clothing during operation.
11. Keep hands, feet, clothing and hair away from moving parts.
12. Keep all bystanders away from the unit when it is operating.
13. Check to see that all controls are in neutral before starting the tractor.

TRANSPORT SAFETY

1. Inflate transport tires to recommended pressure (do not exceed 30 PSI).
2. Do not transport on a public road without a slow moving vehicle sign and appropriate lighting.
3. Never have the mower in operation during transport.
4. Travel speed with a raised triplex mower should not exceed transport tire recommendations.
5. Travel speed should be slow enough to maintain stability of the tractor.

SERVICE AND MAINTENANCE SAFETY

1. Stop engine, set brake, remove key and wait for all moving parts to stop before servicing, adjusting, repairing and unplugging.
2. Block up before working beneath unit.
3. Replace all shields removed during servicing before operating.
4. Never operate triplex in transport position as this will damage PTO universal joints.

The safety signs used on the mower and their location are shown on the following sheet along with the part number for the safety signs.

TRIPLEX MOWER SAFETY SIGNS

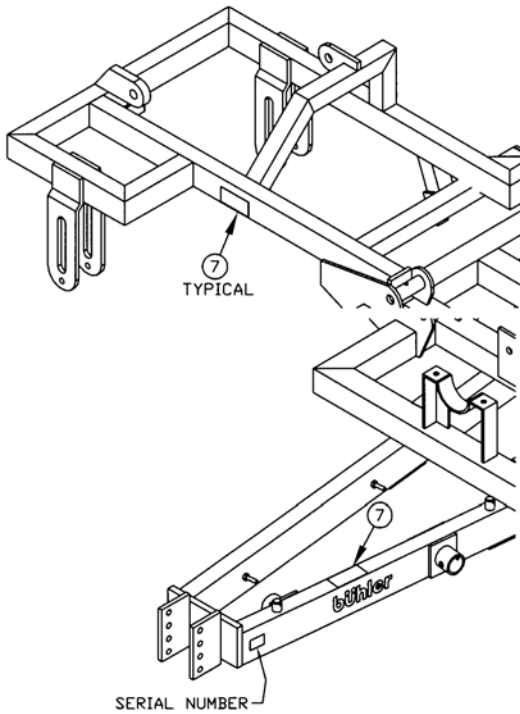

Replace safety signs immediately should they become damaged, torn or illegible. Obtain replacements from your authorized dealer using the part numbers shown.

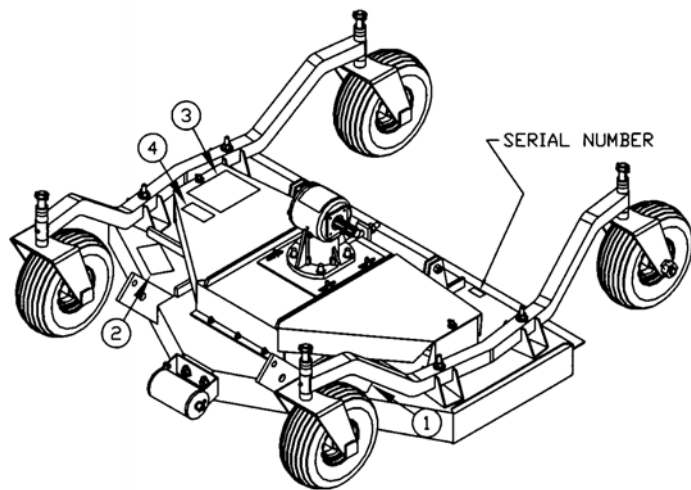
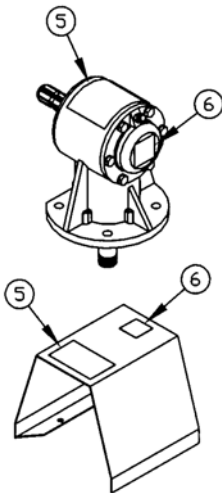
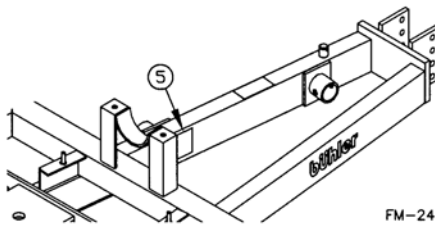

NOTES:
 - DECALS 966701 & 967388 ARE ADDED TO GEARBOX ON SIDE DECKS ONLY

FM-25

TRIPLEX MOWER SAFETY SIGNS – cont'd.

 WARNING
<p>YOU MUST NOT OPERATE THIS MACHINE UNLESS:</p> <ol style="list-style-type: none">1. YOU ARE TRAINED IN ITS SAFE OPERATION AND2. YOU KNOW AND FOLLOW MANUFACTURER'S SAFETY AND OPERATING INSTRUCTIONS AS OUTLINED IN THE OPERATOR'S MANUAL. <p>AN UNTRAINED OPERATOR SUBJECTS HIMSELF AND OTHERS TO SERIOUS INJURY OR DEATH.</p> <p style="text-align: right;"><small>966702</small></p>

#1

 CAUTION
<ul style="list-style-type: none">-READ OPERATOR'S MANUAL BEFORE USING.-ONLY TRAINED, COMPETENT PERSONS SHALL OPERATE THIS EQUIPMENT.-KEEP ALL SHIELDS IN PLACE.-KEEP HANDS, FEET, CLOTHING AND HAIR AWAY FROM MOVING PARTS.-STOP ENGINE, SET BRAKE, REMOVE KEY AND WAIT FOR ALL MOVING PARTS TO STOP BEFORE SERVICING, ADJUSTING, REPAIRING AND UNPLUGGING.-REMOVE BYSTANDERS, ESPECIALLY CHILDREN, BEFORE STARTING OR WHILE OPERATING.-BLOCK UP BEFORE WORKING BENEATH UNIT.-LOWER THE MOWER WHEN PARKING OR STORING.-REVIEW SAFETY INSTRUCTIONS ANNUALLY. <p style="text-align: right;"><small>966703</small></p>

#2

 DANGER

<p>KEEP AWAY - ROTATING BLADES</p> <p>SERIOUS INJURY OR DEATH CAN RESULT FROM THROWN OBJECTS OR BLADE CONTACT.</p> <ul style="list-style-type: none">- DO NOT STAND ON OR NEAR MACHINE WHEN IN OPERATION.- DO NOT OPERATE WITH DEFLECTORS OR GUARDS REMOVED.- USE SPECIAL CARE WHEN OPERATING IN POPULATED OR CONGESTED AREAS. <p style="text-align: right;"><small>966704</small></p>

#3

TRIPLEX MOWER SAFETY SIGNS – cont'd.



#4



#6

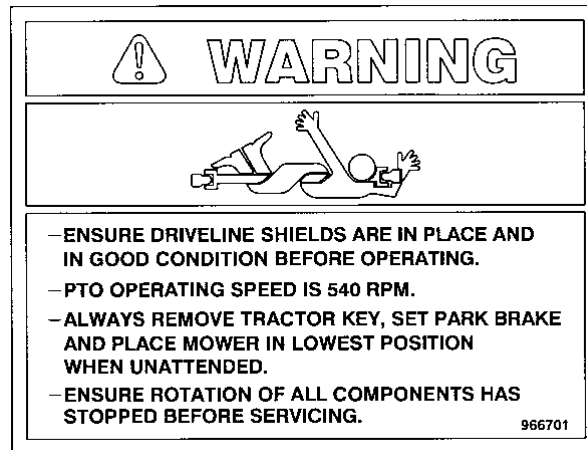

#5

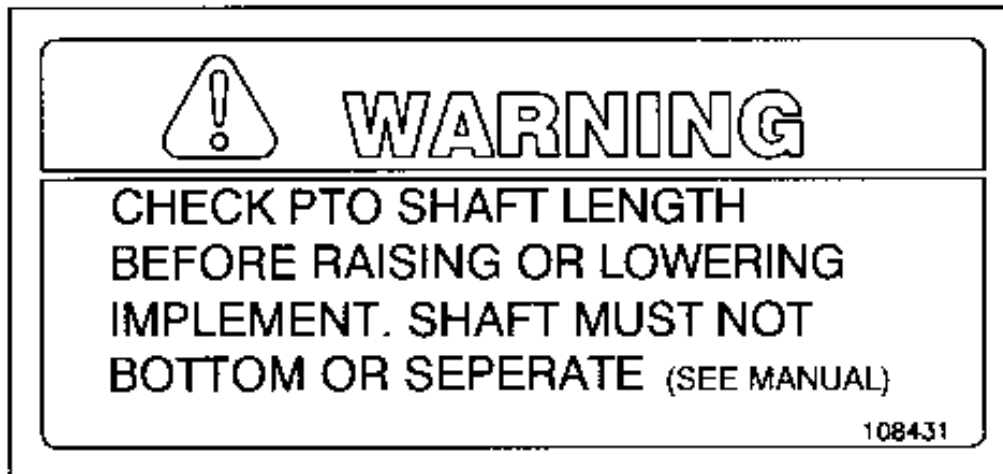

#7

TRIPLEX ASSEMBLY INSTRUCTIONS

1. Pull apart the main frame bundle and separate the parts. Identify and locate parts using drawings and parts lists.
2. Page 20 **(4')** & 38 **(5' –7')**: Mount the stub axles (#4) to both sides of the main frame (#1) using $\frac{1}{2}$ " x $1 \frac{3}{4}$ " hex bolts, lock washers and hex nuts. **5' & 6' ONLY:** Two axle extensions (#2) must be bolted to the main frame before bolting on the stub axles. The u-shaped notch on the flat plate should face the back of the frame. The stub axles then bolt to these axle extensions.

All stub axle weldments are offset to improve clearance between transport wheels and mower wheels. The narrow side of the offset is turned to the bottom of the mainframe for 4 foot mowers. The narrow side of the offset is turned to the back of the main frame for 5 foot and 6 foot mowers. For 7 foot mowers the narrow side of the offset is turned to the front of the main frame.

Mount wheels and tires to the stub axles using $\frac{1}{2}$ " wheel bolts. Level the frame by mounting the jack (#10) at the front.

3. Page 22 **(4')** & 40 **(5' – 7')**: Mount the left and right wings (#1) to the main frame using 1 " x $3 \frac{1}{4}$ " pins (#11) **(4')** or 1 " x $5 \frac{5}{8}$ " pins (#12) **(5' – 7')** and $\frac{1}{4}$ " x $1 \frac{1}{2}$ " cotter pins. The offset part of the side wing faces the front of the frame as shown in drawing. Install a 1 " x 7 " pin (#13) **(4')** or a 1 " x $6 \frac{1}{8}$ " pin (#13) **(5' – 7')** through the two clevises at the top of each side wing. These will be used for the side latch.
4. Page 28 **(4')** or 46 **(5' – 7')**: Install 18 " **(4')** or 20 " **(5' – 7')** cylinders (#1) on each side wing. The base of the cylinder attaches to the gearbox cover (#7, pages 26 & 44) and the rod end to the welded cylinder clevis on the side wings. Cylinder ports should face the front of the frame. Use 4 " pins supplied with cylinder at both base ends, and 1 " x $4 \frac{3}{8}$ " pins (#17) at top ends.

(4'): Install the other 18 " cylinder (#1) on the rear wing (#1, Page 22). The base of the cylinder attaches to the gearbox cover weldment (#7, page 26). Use 1 " x $3 \frac{1}{4}$ " pins (#15) at each end of the cylinder.

(5' – 7'): **Install** the 8 " cylinder (#2) on the rear wing (#1, p.40). The base of the cylinder attaches to the main frame just below the rear latch (#4, page 44). The rod end of the cylinder attaches to the lower hole in the welded bracket on the rear wing (#1, page 42). Cylinder ports face to the outside of the frame. Use 1 " x $4 \frac{1}{2}$ " pins (#22) at both ends of cylinder.

TRIPLEX ASSEMBLY INSTRUCTIONS – cont'd.

5. Page 28 (4'): Install restrictor valves (#18) in all six cylinder ports. The center cylinder, use both 30" hoses (#5) at base and at top. The side cylinders use a 48" hose (#6) at top and a 30" hose (#4) at the base of the cylinder.

Page 46 (5' – 7'): Install restrictor valves (#3) in all six cylinder ports. The 8" cylinder uses a 18" hose (#6) at the base and a 24" hose (#5) at the top of the cylinder. The 20" cylinders use a 34" hose (#7) at the base and a 54" hose (#8) at the top of the cylinder.

⚠ ALERT: All 3 hoses from the base of the cylinders must connect to the same hydraulic line. Likewise all 3 hoses from the top of the cylinders connect to the same hydraulic line. **Serious damage will result if this is not done.**

6. Page 26 (4'): Bolt the latch stand (#1) to the gearbox cover (#7) using $\frac{1}{2}$ " x $1 \frac{1}{2}$ " hex bolts, lock washers and hex nut. The flat irons welded to the rod weldment face to the rear of the main frame. Bolt the side latches (#6) to the top of the latch stand using $\frac{3}{4}$ " x 3" hex bolts (#19) and lock nuts (#20). The latches must swivel freely after tightening the lock nuts. The welded brackets on the side face the back of the main frame and the hooks on the ends face down. The two short springs (#10) hook from the welded bracket on both side latches to the brackets welded to the latch stand. The long spring (#9) hooks onto the side of the rear latch and to a welded piece just below on the main frame. Install 2 – 1" x $3 \frac{1}{4}$ " pins (#8, page 24) on the rear wing.

Page 44 (5' – 7'): Bolt the latch stand (#1) to the gearbox cover (#7) using $\frac{1}{2}$ " x $1 \frac{1}{2}$ " hex bolts, lock washers and hex nuts. Bolt the rod supports (#3) to the stand using the same size of hardware. The rod supports should face the front of the main frame. Bolt to outside of welded brackets. The latch rod weldment (#2) fits through the 1" holes in the rod supports (#3). This must be assembled just prior to bolting on the rod supports. The flat irons welded to the rod weldment face to the rear of the main frame. Bolt the left and right side latch (#5 & #6) to the top of the latch stand using $\frac{5}{8}$ " x $4 \frac{1}{2}$ " hex bolt and lock nuts. The latches must swivel freely after tightening the lock nuts. The welded brackets on the side face the back of the main frame and the hooks on the ends face down. The two short springs (#9) hook from the welded bracket on both side latches to the brackets welded to the latch stand. The long spring (#8) hooks onto the side of the rear latch (#4) and to a welded piece just below on the main frame. Install a 1" x $5 \frac{5}{8}$ " pin (#10, page 42) in the upper hole on the rear wing just above the cylinder pin.

7. Page 26 (4'): Bolt the latch cable (#3) to the long bracket facing up using a $\frac{3}{8}$ " x $1 \frac{1}{4}$ " hex bolt. Bolt the end of one 20 link chain (#12) to the chain tightener (#27) and the other end of the chain to the welded bracket on the rear latch (#4 & #5) using $\frac{3}{8}$ " x $1 \frac{1}{4}$ " hex bolts, flat washers, lock washers and hex nuts. The 6 link chains (#11) bolt to the inner hole on the bracket and to the top of the side latch (#6). The 6 link chain connects to each side latch.

TRIPLEX ASSEMBLY INSTRUCTIONS – cont'd.

Page 44 (5' – 7'): There are 4 flat irons welded to the latch rod weldment (#2). Ignore the bottom one with the double clevis. Bolt the latch cable (#12) to the long bracket facing up using a 3/8" x 1" hex bolt. Bolt one end of the 26 link chain (#11) to the chain tightener (#29) and the other end of the chain to the welded bracket on the rear latch (#4) using 3/8" x 1 1/4" hex bolts, flat washers, lock washers and hex nuts. The 6 link chains (#10) bolt to the open hole on the latch weldment flat irons (#2) and to the top of the side latch (#5 & #6). A 6 link chain connects to each side latch.

8.  **PAGES 30 & 33 (4'):** Mount tires in the yokes on all the mower decks.
ALERT: 4' mower only gets two tires on the center mower, 3 tires on side decks.

-  **PAGES 48 & 51 (5' – 7'):** Mount tires in the yokes on all the mower decks.
ALERT: 5' & 6' mower only get two tires on the center mower.

9. Page 22 (4'): Bolt the deck mounts (#2) to the left and right mowers. The deck mounts are left and right. The cross bar goes to the outside of the mower as shown in the drawing. The square flat iron bolts between the two brackets welded to the front of the mower decks using hardware in the deck. The tapered flat irons bolt to the inside of the plates welded to the back of mower deck.

Page 40 (5' – 7'): Bolt the deck mounts (#2) to the left and right mowers. The deck mounts are left and right. The cross bar goes to the outside of the mower as shown in the drawing. The square flat iron bolts between the two brackets welded to the back of the mower decks using hardware in the deck. The tapered flat irons bolt to the inside of the plates welded to the front of mower deck.

10. Page 22 (4'): Connect left and right mowers to the side wings. The slots in the side wings fit over the bushings in the deck mounts. Insert 1" x 5 5/8" pins (#12) with a flat washer on each side and a poly wear washer on both sides of the bushing. Hold in place with a 1/4" x 1 1/2" cotter pin. A 5/8" x 5" bolt fits through the round hole under the slot. This bolt goes through a 3 1/8" long bushing which fits under the cross bar on the deck mount. Use a lock washer and hex nut.
 **ALERT:** The 5" bolt must be installed with the head on the inside or the tip of the bolt will hook on the tightener rod on the mower gearbox.

Page 40 (5' – 7'): Connect left and right mowers to the side wings. The slots in the side wings fit over the bushings in the deck mounts. Insert 1" x 5 5/8" pins (#12) with a flat washer on each side and a poly wear washer on both sides of the bushing. Hold in place with a 1/4" x 1 1/2" cotter pin. A 5/8" x 5" bolt fits through the round hole under the slot. This bolt goes through a 3 1/8" long bushing which fits under the cross bar on the deck mount. Use a lock washer and hex nut.

-  **ALERT:** The 5" bolt must be installed with the head on the inside or the tip of the bolt will hook on the tightener rod on the mower gearbox.

TRIPLEX ASSEMBLY INSTRUCTIONS – cont'd.

11. Page 24 (4'): Mount the rear mower to the rear wing. The 1" x 29 3/8" rear wing bar (#3) fits through the slots in the rear wing and the 1" holes in the brackets welded to the front of the mower. Put a poly wear washer under a flat washer and cotter pin at each end of the bar.

⚠ ALERT: One transport tire must be removed from the main frame to insert this pin. Bolt the two pivot bars (#2) to the rear mower. The end with the round hole bolts to the top of the rear wing using a 5/8" x 3" hex bolt and lock nut. The bar must still turn freely after tightening. The slotted end bolts between the two brackets welded to the back of the mower deck using hardware in the deck.

Page 42 (5' – 7'): Mount the rear mower to the rear wing. The 1" x 29 3/8" rear wing bar (#3) fits through the slots in the rear wing and the 1" holes in the brackets welded to the front of the mower. Put a poly wear washer under a flat washer and cotter pin at each end of the bar.

⚠ ALERT: One transport tire must be removed from the main frame to insert this pin. Bolt the two pivot bars (#2) to the rear mower. The end with the round hole bolts to the top of the rear wing using 5/8" x 2" hex bolts and lock nuts. The bar must still turn freely after tightening. The slotted end bolts between the two brackets welded to the back of the mower deck using hardware in the deck.

5' & 6' ONLY: The stubs at the front of the axles should be positioned inside the u-shaped area on top of the axle extensions (#2, page 38).

12. Page 36 (4'): Bolt the PTO guards to the gearboxes. The large guard (#7) bolts to the front of the main frame gearbox using 3/8" x 3/4" hex bolts, flat washers and lock washers. The small guards will have two different hole patterns. One guard (#6) bolts to the back of the main frame gearbox using the same hardware as above. The other two guards (#60, page 30) bolt to the left and right mower gearboxes using 5/16" x 5/8" hex bolts, flatwashers and lock washers.

Page 54 (5' – 7'): Bolt the PTO guards to the gearboxes. The large guard (#7) bolts to the front of the main frame gearbox using 3/8" x 3/4" hex bolts, flat washers and lock washers. The small guards will have two different hole patterns. One guard (#6) bolts to the back of the main frame gearbox using the same hardware as above. The other two guards (#60, page 48) bolt to the left and right mower gearboxes using 5/16" x 5/8" hex bolts, flat washers and lock washers.

13. Page 36 (4'): Attach the PTO shafts. The large CV PTO (#3) attaches to the front of the gearbox with the CV end resting in the PTO stand at the front of the main frame. On the 4' mower all three mowers PTO's are the same.

TRIPLEX ASSEMBLY INSTRUCTIONS - cont'd.

Page 54 (5' – 7'): Attach the PTO shafts. The large CV PTO (#3) attaches to the front of the gearbox with the CV end resting in the PTO stand at the front of the main frame. For the 5' & 6' mowers the rear PTO (#4) is the longest of the three mower PTO's. On the 7' mower all three mowers PTO's are the same. The PTO's to the side mowers (#5) are always the same size.

14. (5' – 7'): Mount the toolbox weldment to the PTO assembly with the parts and hardware shown. Make sure that the toolbox is mounted as far as possible back to the gearbox.

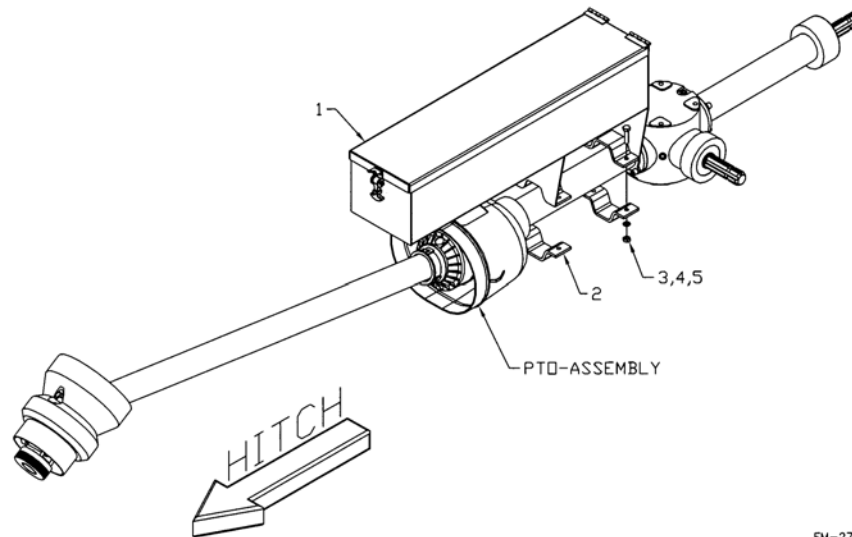

FM-27

5' - 7' TRIPLEX MOWER TOOLBOX PARTS LIST

ITEM	PART#	DESCRIPTION	QTY
1	909701	Toolbox Weldment	1
2	909695	Bottom Pipe Bracket	2
3	811792	3/8" x 1 1/2" Hex Bolt (pl)	4
4	81592	3/8" Hex Nut (pl)	4
5	81593	3/8" Lock Washer (pl)	4

15. Page 19 (4'): Bolt the hose holder (#3) to the front of the main frame. Bolt the hose holder to the hold at the end of the frame bracket using a ½" x 1 ½" hex bolt, flat washer, lock washer and hex nut.

Page 37 (5' – 7'): Bolt the hose holder (#3) to the front of the main frame. The 5 ½" long pigtail bracket (#34) goes under the frame and the 11 3/8" pigtail bracket (#38) goes on top. Bolt together using two ½" x 6" hex bolts, lock washers and hex nut. Bolt the hose holder to the hold at the end of the 11 3/8" pigtail bracket using a ½" x 1 ½" hex bolt, flat washer, lock washer and hex nut.

16. Page 19 (4'): Assemble the front clevis to the frame using four 5/8" x 1 ¾" hex bolts, lock washers and hex nuts.

Page 37 (5' – 7'): Assemble the front clevis to the frame using four 5/8" x 1 ¾" hex bolts, lock washers and hex nuts.

17. Page 28 (4'): Attach the two 84" hoses (#3) to the hydraulic lines. The ends of the hose hang in the hose holder (page 19, #3).

Page 46 (5' – 7'): Attach the two 84" hoses (#4) to the hydraulic lines. The ends of the hose hang in the hose holder (page 37, #3).

18. Check the following after assembly:

- 1) Check that all hardware is installed and tight.
- 2) Check that all shields on mowers and frame are installed and tight.
- 3) Joints secured with lock nuts that must swivel during operation must turn freely after tightening.
- 4) Check that PTO ends are securely attached.
- 5) Check that all hydraulic fittings are tight. Leaks in hydraulics can cause serious eye injuries.
- 6) Check that all hoses are attached to the correct hydraulic line as per step #5.
- 7) With the frame in transport position, pull the latch cable. Be certain all three latches release fully. Adjust chain length if necessary.

TRIPLEX HARNESS ROUTING

When installing the light kits, run the harness as shown on the following illustrations.

Be careful not to run the cables on the outlined areas because they could get damaged.

NOTE: The 7' Triplex does not have axle extensions.

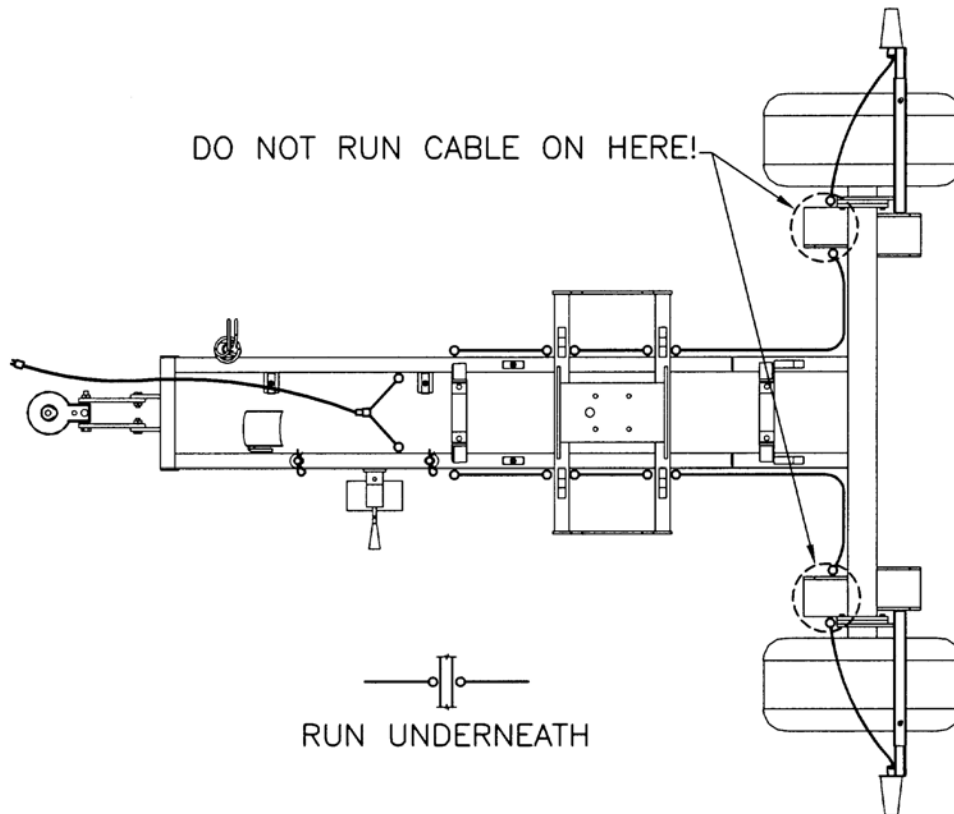
4' TRIPLEX

FM-28

TRIPLEX HARNESS ROUTING – cont'd.

5' & 7' TRIPLEX

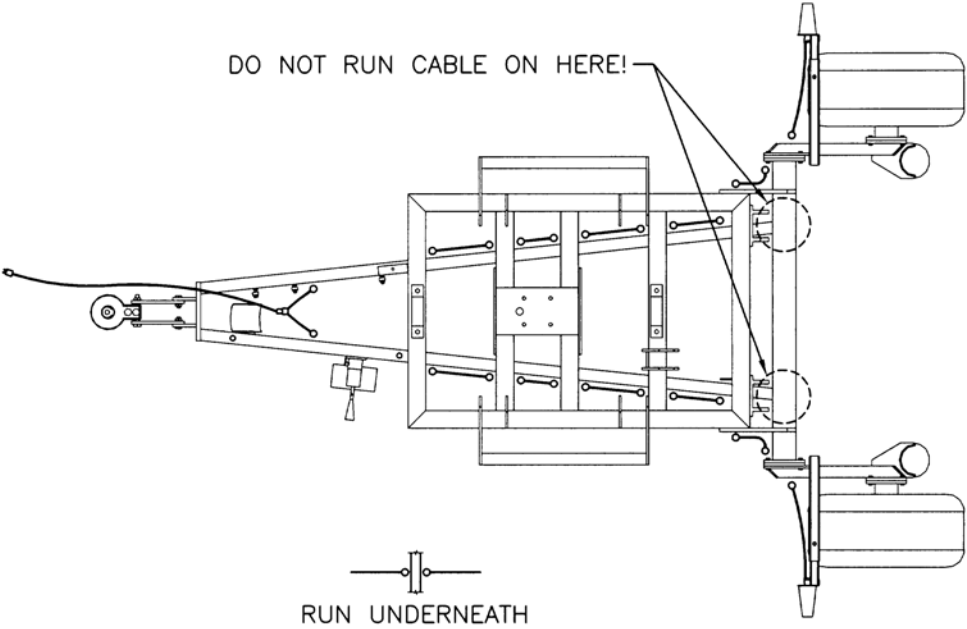

FM-29

6' TRIPLEX

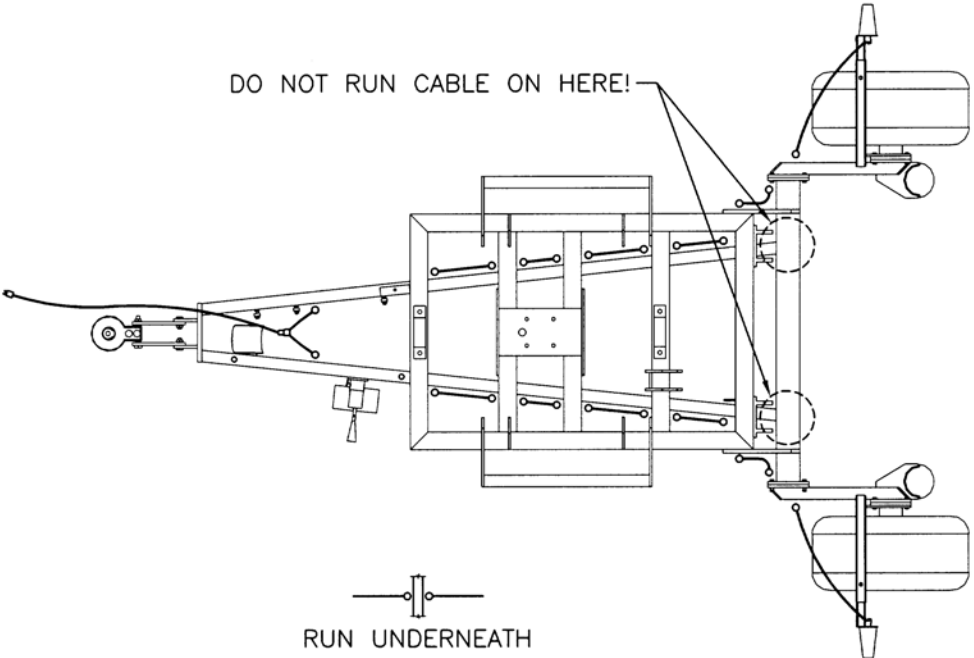

FM-30

MAINTENANCE

1. Gearboxes: The gearboxes should be filled with SAE 90 oil to the bottom of level plug when shipped. Check the mowers and splitter box before using and at regular intervals (approx. every 40 hours). See that this oil level is maintained.

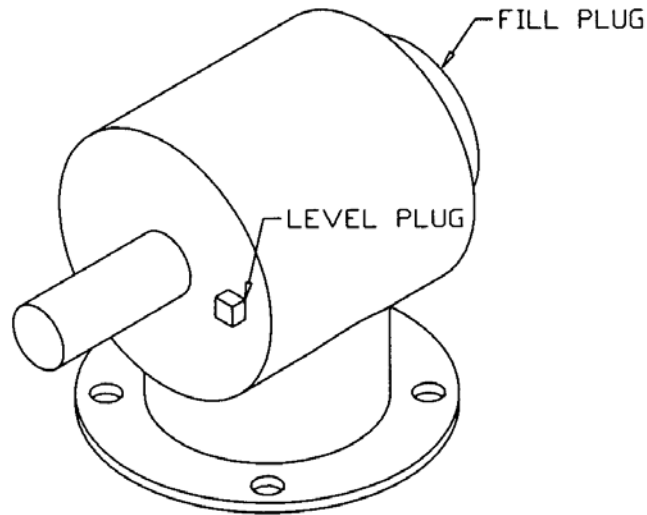

FM-60

2. Grease wing assemblies, wheel yokes and PTO u-joints approximately every 8 hours. Lubricate the telescoping PTO tube and the quick release collars on the ends of the shaft about every 20 hours. Clean all grease fittings before injecting grease and immediately replace any damaged or missing grease fittings. When using the safety chains supplied with the PTO shaft, the shield bearings must be kept lubricated. Transport wheel bearings should be repacked once a year.

The mower wheel bearings are packed in grease when they are shipped. They should be re-packed in fresh grease once a year or every 200 hours of usage.

3. Shielding: Always keep all shielding in place and repair or replace if damaged.
4. Blades: When replacing or grinding blades, all blades must be replaced or reground at the same time to maintain the proper balance in the cutting unit. Block up the mower securely before attempting to remove the blades. Use heavy leather gloves to handle the blades. Be sure to tighten center bolt and lock washer securely when replacing blades. Use a torque wrench to re-tighten spindle bolts to 180 ft-lbs. The bolts have a patch of thread lock material pre-applied which will hold for up to five usages. Always replace the lock washer with an extra heavy duty as supplied with the spindle.

MAINTENANCE – cont'd.

5. Belts: Remove the belt guards to check belt tightness. The center of the belt span should deflect about $\frac{1}{2}$ " with nominal pressure. If the belts slip or are too loose, the bolts holding the gearbox must be loosened. Use the threaded tightener rod on the gearbox mount to tighten the belts. Lock the rod in place and re-tighten the gearbox bolts when the belts are properly tightened. Replace belt guards.

Changing belts follows the same procedure as given in the preceding paragraph, except you will have to loosen the belts further to remove them. The belt installation is shown in the following drawing.



ALERT Belts should always be replaced in matched sets.

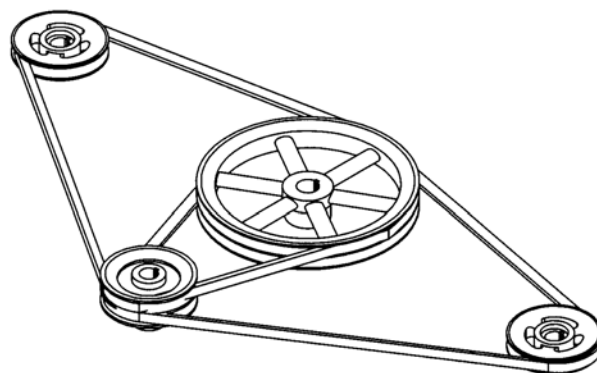

FM-61

BOLT TORQUE

CHECKING BOLT TORQUE

The tables shown below give correct torque values for various bolts and hex bolts. Tighten all bolts to the torques specified in chart unless otherwise noted. Check tightness of bolts periodically, using bolt torque chart as a guide. Replace hardware with the same strength bolt.

ENGLISH TORQUE SPECIFICATIONS

Bolt Diameter "A"	Bolt Torque *					
	SAE2		SAE 5		SAE 8	
N.m	(lb-ft)	N.m	(lb-ft)	N.m	(lb-ft)	
1/4"	8	(6)	12	(9)	17	(12)
5/16"	13	(10)	25	(19)	36	(27)
3/8"	27	(20)	45	(33)	63	(45)
7/16"	41	(30)	72	(53)	100	(75)
1/2"	61	(45)	110	(80)	155	(115)
9/16"	95	(70)	155	(115)	220	(165)
5/8"	128	(95)	215	(160)	305	(220)
3/4"	225	(165)	390	(290)	540	(400)
7/8"	230	(170)	570	(420)	880	(650)
1"	345	(225)	850	(630)	1320	(970)

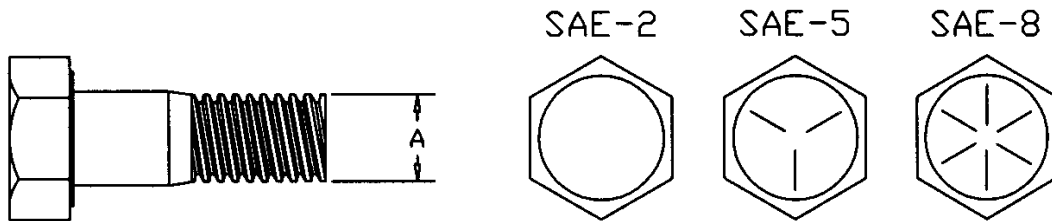

FM-62

⚠ ALERT See page 11 for correct spindle torque.

Torque figures indicated above are valid for non-greased or non-oiled threads and heads unless otherwise specified. Therefore, do not grease or oil bolts or hex bolts unless otherwise specified in this manual. When using lock elements, increase torque values by 5%.

- Torque value for bolts and hex bolts are identified by their head markings.

TRIPLEX HITCH ASSEMBLY

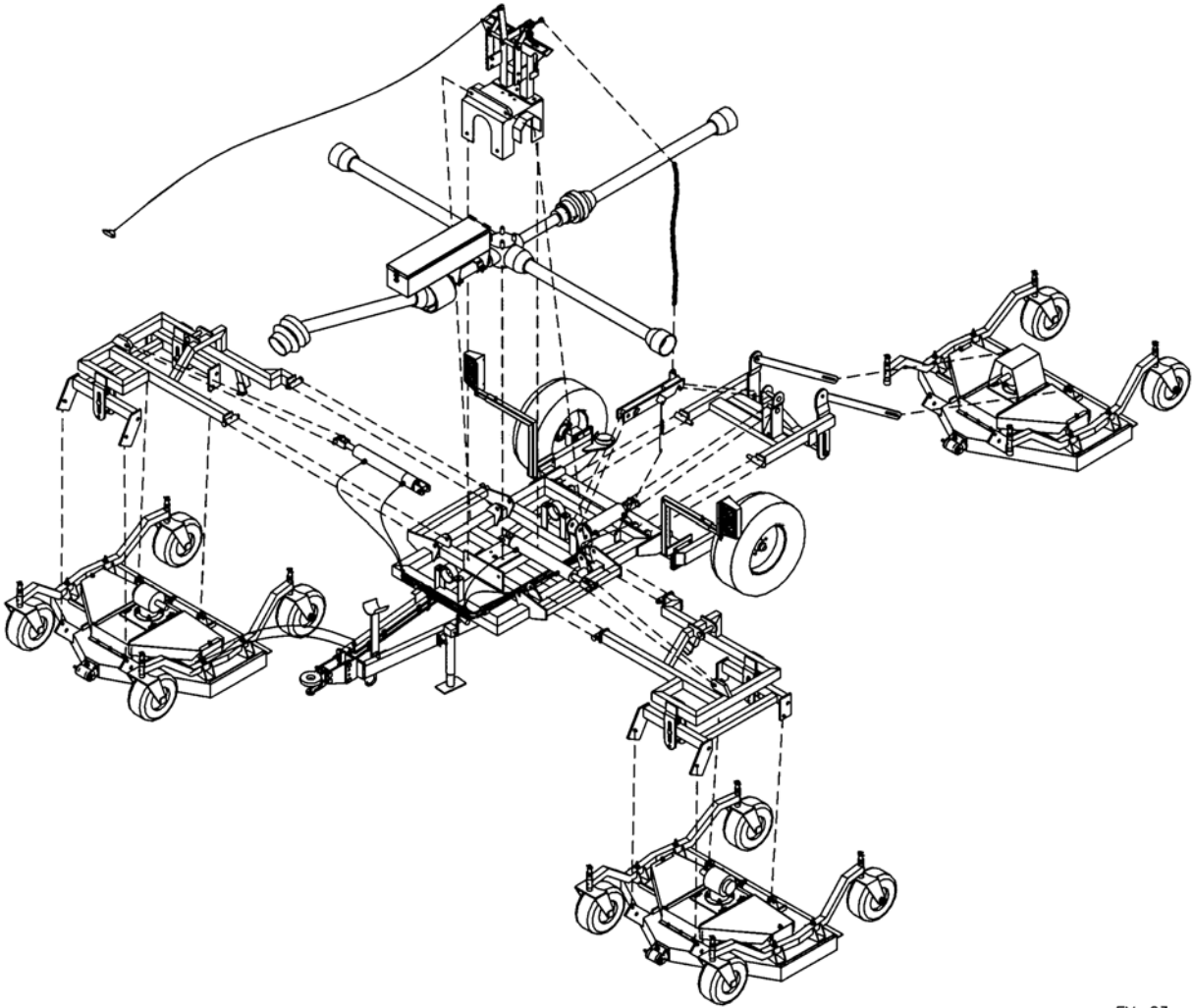

FM-23

WHEN ORDERING PARTS

Always give your dealer the Model, Color and Serial Number of your machine to assist him in ordering and obtaining the correct parts. Use the exploded view and tabular listing of the area of interest to exactly identify the required part.

4' TRIPLEX HITCH MAIN FRAME ASSEMBLY

ITEM	PART #	DESCRIPTION
1	903597	Main Frame Weldment
2	811795	3/8" x 2" Hex Bolt (pl)
3	966313	Hydraulic Hose Holder
4	900699	Stub Axle Weldment
5	900730	PTO Holder Weldment
6	905027	Hitch Side Plate (Standard)
7	966302	Tire 27 x 10.5 x 15
	966303	Wheel 15" x 8" x 5 Bolt
8	903595	PTO Holder Clamp
9	11362	Clip Pipe Standard
10	960327	Jack Assembly
11	968430	Oil Seal (SE 14X)
12	967208	Inner Cone (LM48548)
13	968412	Inner Cup (LM48510)
14	968403	Hub with Bearing Cups (H516)
15	968405	Outer Cup (LM11910)
16	968406	Outer Cone (LM11949)
17	84050	3/4" S.A.E. Flat Washer (pl)
18	81834	3/4" Slotted Hex Nut (br)
19	968409	Dust Cap (DC12)
20	9812486	1/8" x 1 1/2" Cotter Pin
21	81638	1/2" Flat Washer (pl)
22	81592	3/8" Hex Nut (pl)
23	81593	3/8" Lock Washer (pl)
24	84277	1/2" x 1 1/2" Hex Bolt (pl)
25	87553	1/2" x 1 3/4" Hex Bolt (pl)
26	811691	1/2" x 4 1/2" Hex Bolt (pl)
27	81637	1/2" Lock Washer (pl)
28	81636	1/2" Hex Nut (pl)
29	968404	1/2" x 1 1/4" Wheel Bolt (pl)
30	961012	#16 Hair Pin Clip (pl)
31	81673	5/8" x 5" Hex Bolt (pl)
32	84270	5/8" x 1 3/4" Hex Bolt (pl)
33	81677	5/8" Lock Washer (pl)

34	81676	5/8" Hex Nut (pl)
35	968431	Hub Assembly
36	900712	PTO Stand Pin 5/8"Dia. x 3" Long
37	905039	Wing Transport Arm 20" Long
38	12779	Hair Pin Clip #9 Western Wire
39	905041	Clevis Bolt-On
40	905040	Hitch Base
41	905036	Hitch Connector Weldment - (Optional)
42	967900	1/4" Grease Fitting
43	909693	Light Bracket Weldment - Right
44	909694	Light Bracket Weldment - Left
45	909691	Hitch Bracket Weldment - Right
46	909692	Hitch Bracket Weldment - Left
47	81213	3/8" x 1" Square Head Setscrew (pl)
48	81624	1/2" x 2 1/4" Hex Bolt (pl)

4' TRIPLEX HITCH SIDE WING ASSEMBLY

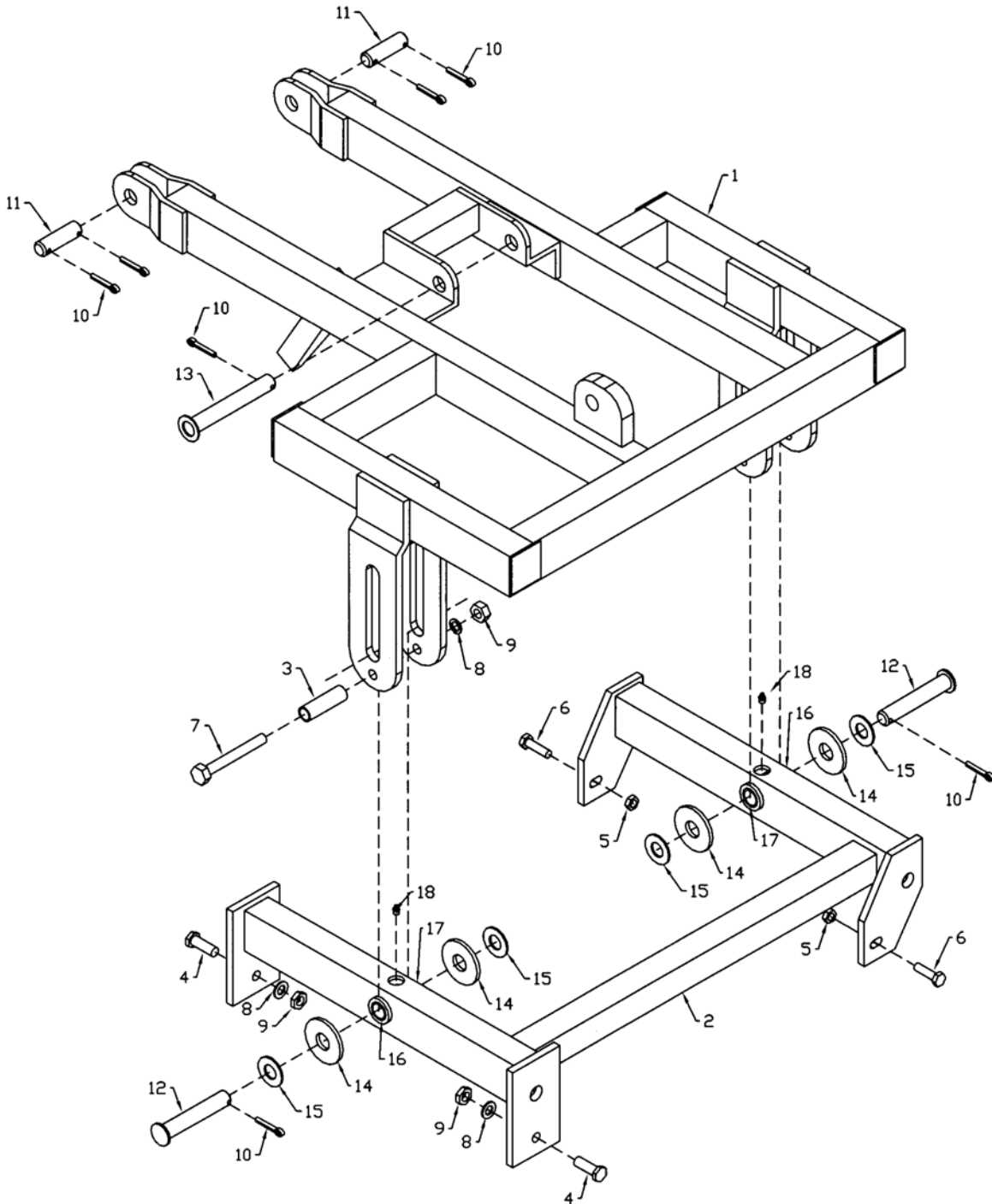

FM-13

4' TRIPLEX HITCH SIDE WING ASSEMBLY

ITEM	PART #	DESCRIPTION
1	903625	4' Left Hand Side Wing Weldment
	903626	4' Right Hand Side Wing Weldment
2	903630	4' Left Hand Deck Mount Weldment
	903631	4' Right Hand Deck Mount Weldment
3	900735	Deck Spacer 1" O.D. x 3 1/8" Long
4	84270	5/8" x 1 3/4" Hex Bolt (pl)
5	812364	1/2" Lock Nut (pl)
6	87553	1/2" x 1 3/4" Hex Bolt (pl)
7	81673	5/8" x 5" Hex Bolt (pl)
8	81677	5/8" Lock Washer (pl)
9	81676	5/8" Hex Nut (pl)
10	9812434	1/4" x 1 1/2" Cotter Pin (pl)
11	903692	Pin 1" x 3 1/4" Long
12	901399	Clevis Pin 1" x 5 5/8" Long
13	903691	Clevis Pin 1" x 7" Long
14	902411	Wear Washer 3" x 1/4" Thick
15	84522	1" Flat Washer S.A.E. BS (pl)
16	113577	Bushing 1" I.D. x 1 1/4" O.D. x 1 3/8" Long
17	113780	Bushing 1" I.D. x 1 1/4" O.D. x 0.88" Long
18	967164	Pound-In Grease Nipple

4' TRIPLEX HITCH REAR WING ASSEMBLY

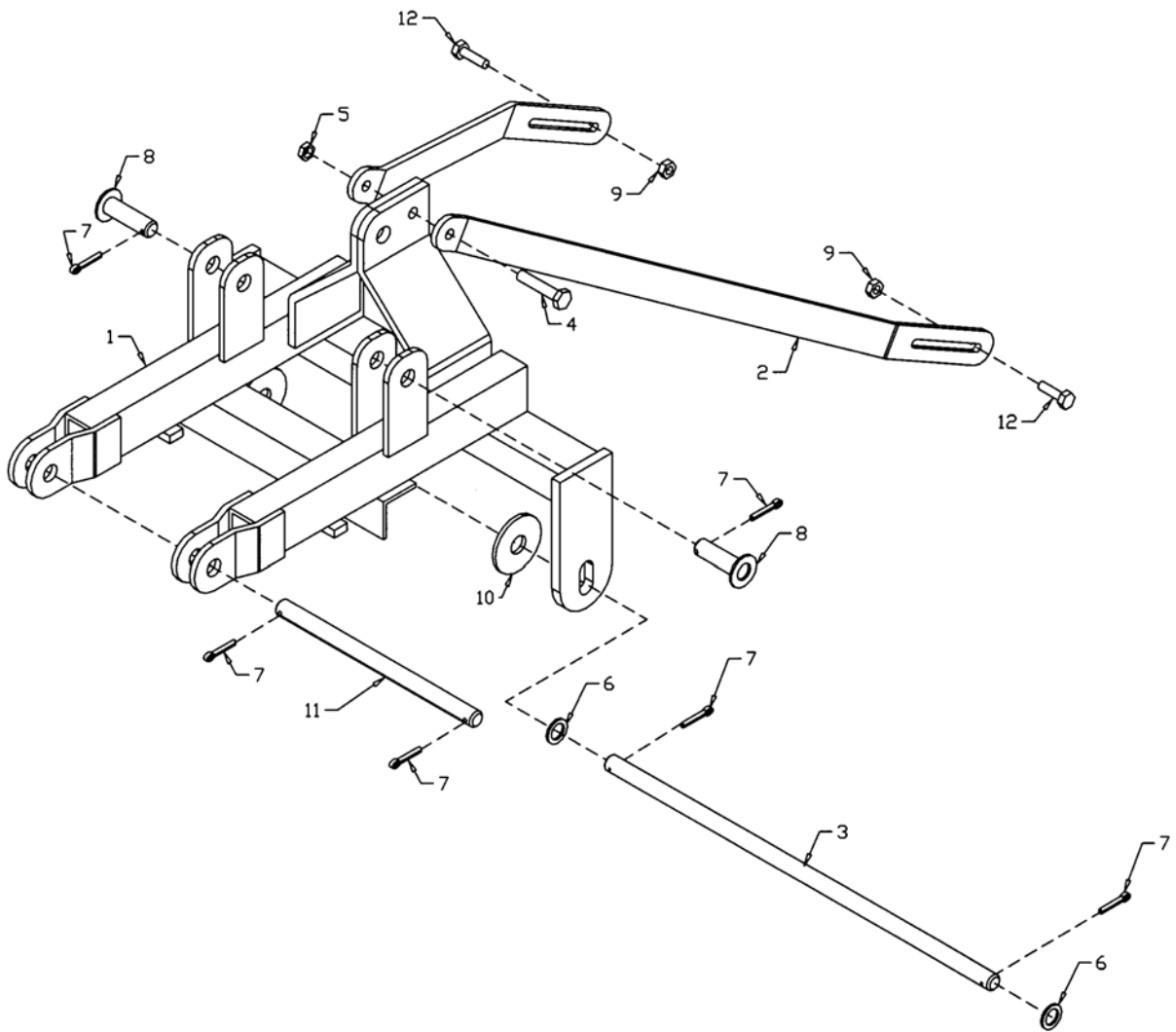

FM-15

4' TRIPLEX HITCH REAR WING ASSEMBLY

ITEM	PART #	DESCRIPTION
1	903614	Rear Wing Weldment
2	903658	4' Pivot Bar 38" Long
3	900703	Rear Wing Bar 1" x 29 3/8"
4	84289	5/8" x 3" Hex Bolt (pl)
5	812482	5/8" Lock Nut (pl)
6	84522	1" S.A.E. Flat Washer (pl)
7	9812434	1/4" x 1 1/2" Cotter Pin (pl)
8	903837	Pin Weldment 1" x 3 1/4"
9	812364	1/2" Lock Nut (pl)
10	902411	Wear Washer 3" x 1/4" Thick
11	903689	Rear Wing Rod 1" x 15 3/4"
12	87553	1/2" x 1 3/4" Hex Bolt (pl)

4' TRIPLEX HITCH LATCH ASSEMBLY

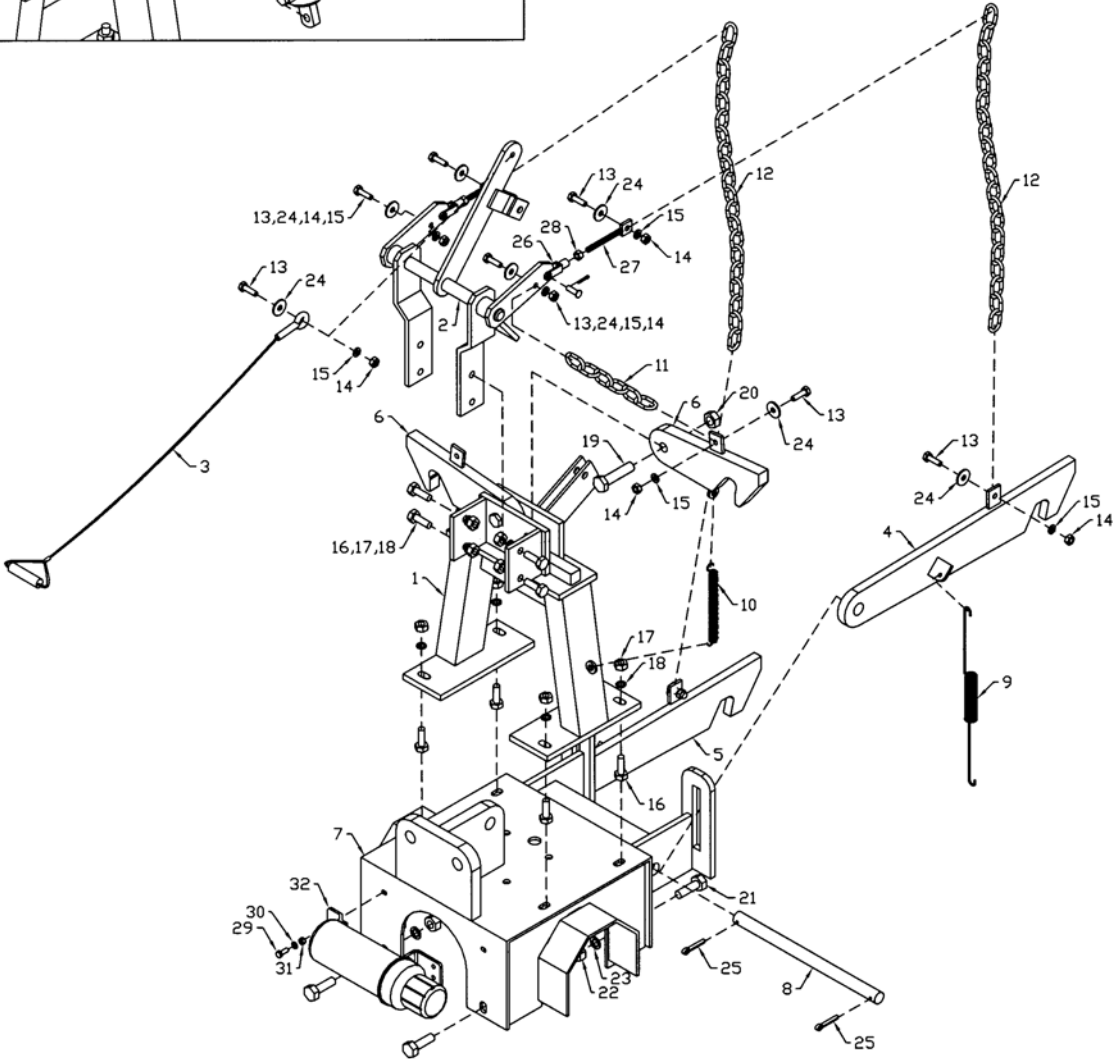
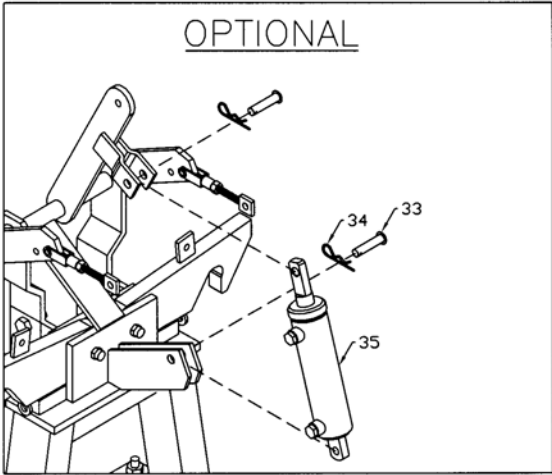

4' TRIPLEX HITCH LATCH ASSEMBLY

ITEM	PART #	DESCRIPTION
1	903640	Latch Stand Weldment
2	903646	Latch Weldment
3	966311	1/8" x 12' Latch Cable Assembly
4	903648	Rear Latch Weldment Right
5	903657	Rear Latch Weldment Left
6	903649	Side Latch Weldment
7	903604	Gearbox Cover Weldment
8	903688	Rear Hook Pin 1" X 15" Long
9	973618	Rear Latch Spring
10	960750	Side Latch Spring
11	966591	1/4" x 6 Link Chain
12	905339	1/4" x 20 Link Chain
13	86171	3/8" x 1 1/4" Hex Bolt (pl)
14	81592	3/8" Hex Nut (pl)
15	81593	3/8" Lock Washer (pl)
16	84277	1/2" x 1 1/2" Hex Bolt (pl)
17	81636	1/2" Hex Nut (pl)
18	81637	1/2" Lock Washer (pl)
19	88742	3/4" x 3" Hex Bolt (pl)
20	812365	3/4" Lock Nut (pl)
21	84270	5/8" x 1 3/4" Hex Bolt (pl)
22	81676	5/8" Hex Nut (pl)
23	81677	5/8" Lock Washer (pl)
24	84000	3/8" Flat Washer (pl)
25	9812434	1/4" x 1 1/2" Cotter Pin (pl)
26	905043	Clevis Yoke with Clevis Pin (H.Paulin AY28)
27	903590	Chain Tightener Rod Weldment
28	8175	3/8" Hex Nut NF (pl)
29	812026	5/16" x 1" Hex Bolt (pl)
30	81569	5/16" Lock Washer (pl)
31	81568	5/16" Hex Nut (pl)
32	909277	Manual Holder
33	961010	1/2" X 2 1/8" Clevis Pin (pl)
34	12779	Hair Pin Clip #9
35	24930	1 3/4" x 5" Cylinder

4' TRIPLEX HITCH HYDRAULIC ASSEMBLY

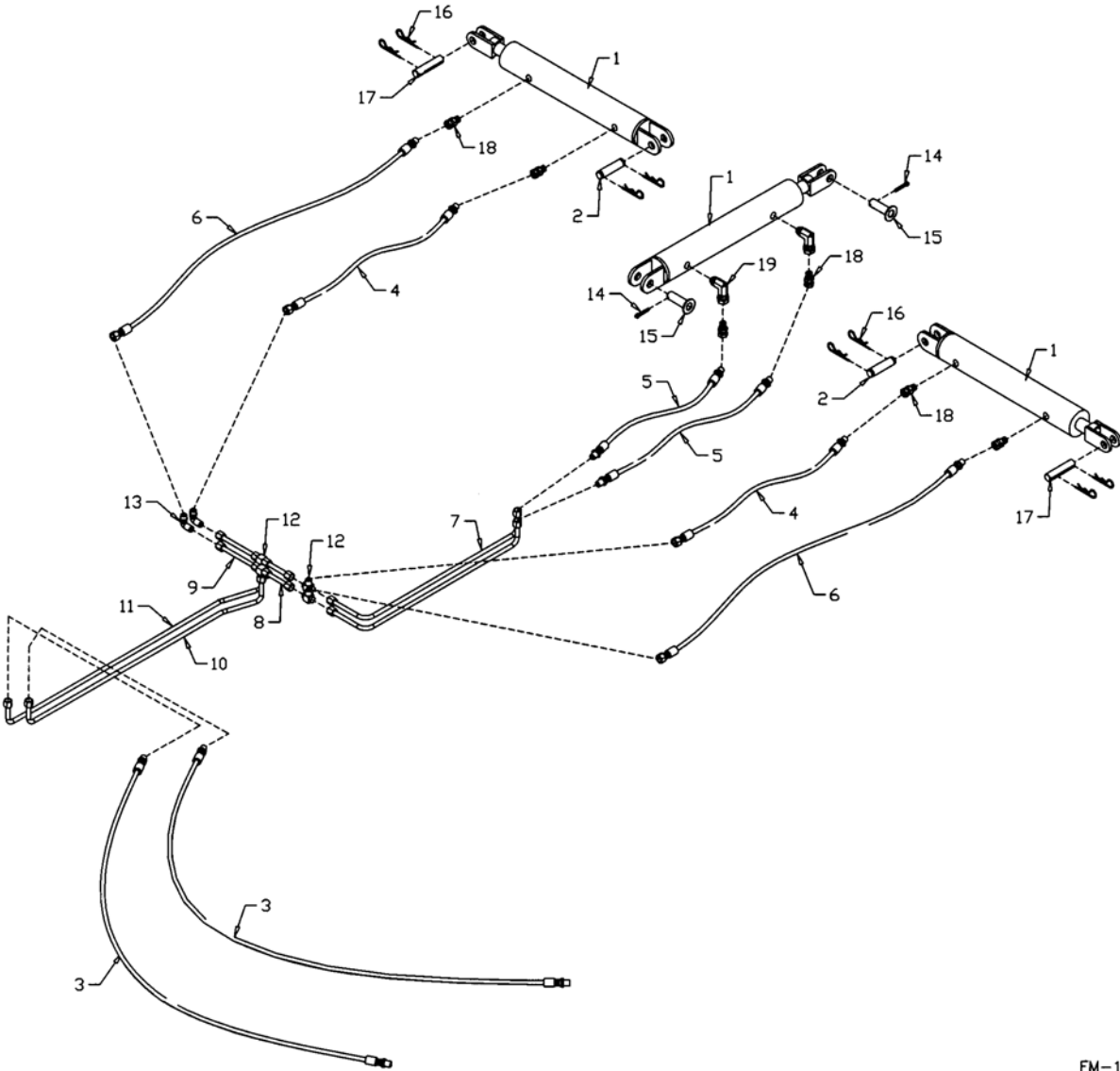

FM-19

4' TRIPLEX HITCH HYDRAULICS ASSEMBLY

ITEM	PART #	DESCRIPTION
1	24932	Cylinder 3"Dia x 18" \ Orb Port
2	103753	Cylinder Clevis Pin 1" Dia. x 4"
3	812861	1/2" x 84" Hose 1/2 MNPT x 3/4 MJIC
4	115670	1/2" x 30" Hose 1/2 SWMNPT x 3/4 SWFJIC
5	115669	1/2" x 30" Hose 1/2 SWMNPT x 3/4 MJIC
6	115671	1/2" x 48" Hose 1/2 SWMNPT x 3/4 SWFJIC
7	903966	Hydraulic Line - Triplex Side
8	903965	Left Hydraulic Line - 4 1/2" Long
9	903079	Right Hydraulic Line - 7" Long
10	903963	Hitch Hydraulic Line - 41"
11	903964	Hitch Hydraulic Line - 44 1/2"
12	812069	Tee 3/4 MJIC
13	812128	Elbow 90 3/4 MJIC x 3/4 MJIC
14	9812434	1/4" x 1 1/2" Cotter Pin (pl)
15	903837	Pin Weldment 1" X 3 1/4"
16	12779	Hair Pin Clip #9 Western Wire
17	905038	Pin 1" x 4 3/8" (3 Holes)
18	966321	Adaptor S01120-8DX.052
19	905392	Elbow 90 3/4" MORB x 3/4" FORB

4' TRIPLEX HITCH SIDE MOWER DECK

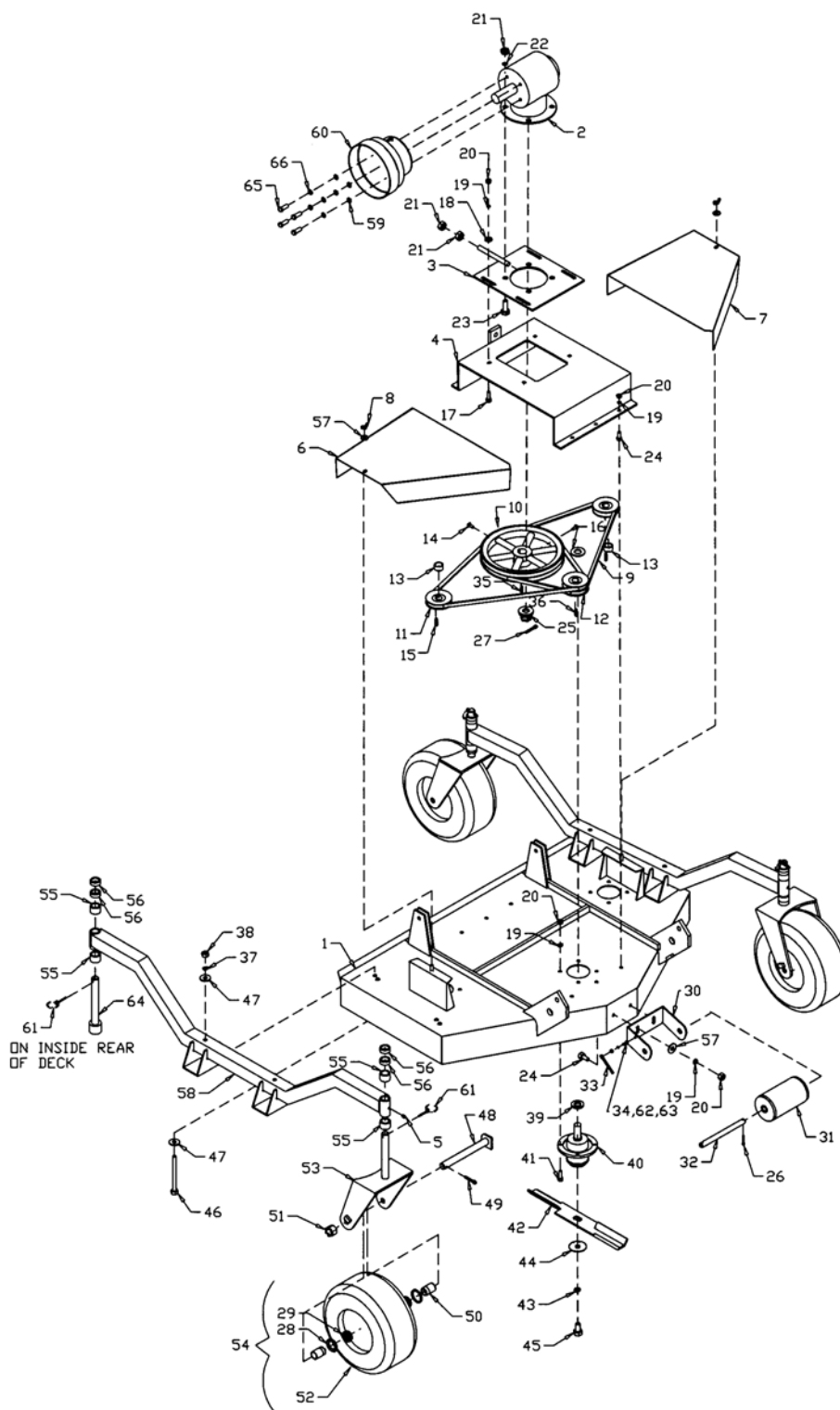

FM-05

4' TRIPLEX SIDE MOWER DECK ASSEMBLY

ITEM	PART#	DESCRIPTION
1	903815	4' Rear Discharge Deck
2	912300158	Gearbox Assembly
3	980004200	Gearbox Base Plate
4	906342	Gearbox Mount Plate
5	967164	Pound-in Grease Nipple
6	906346	4' R.H. Pulley Guard
7	906347	4' L.H. Pulley Guard
8	84217	3/8" Wing Nut (pl)
9	904250	B-61 Belts
10	966722	12" Double Sheave c/w Set Screws
11	904243	3 3/4" Single Sheave Assy (Machined End Up)
12	904244	3 3/4" Double Sheave c/w Set Screws
13	966811	Sheave Spacer 1 1/4" O.D. x .70"
14	9812377	5/16" x 3/4" Sq. Hd. Set Screw (pl)
15	900931	1/4" Square x 1.11" Key
16	967140	Narrow Rim Washer 1" x 10ga (pl)
17	86182	3/8" x 1 1/4" Carriage Bolt (pl)
18	964001	7/16" I.D. x 10ga Washer (pl)
19	81593	3/8" Lock Washer (pl)
20	81592	3/8" Hex Nut (pl)
21	81676	5/8" Hex Nut (pl)
22	81677	5/8" Lock Washer (pl)
23	84270	5/8" x 1 3/4" Hex Bolt (pl)
24	86170	3/8" x 1" Hex Bolt (pl)
25	905247	Washer & Slotted Hex Nut Weldment Included With Gearbox
26	9812434	1/4" x 1 1/2" Cotter Pin (pl)
27	81207	3/16" x 2" Cotter Pin
28	967497	Oil Seal SE10
29	966776	Bearing Cone (L44643) without Grease
30	903488	Roller Holder
31	903113	Roller Tube Assembly
32	903104	Roller Pin 3/4"Dia x 8 3/4" Lg
33	9812436	1/4" x 2 1/2" Cotter Pin (pl)
34	81525	1/4" x 3/4" Hex Bolt (pl)
35	900929	Pulley Key (1/4" Sq. x 1 5/8" Long)
36	900930	1/4" x 1 1/2" Key
37	81637	1/2" Lock Washer (pl)
38	81636	1/2" Hex Nut (pl)
39	912301558	1" Snap Ring
40	966860	Spindle with Hardware
41	86171	3/8" x 1 1/4" Hex Bolt (pl)
42	903798	17 3/4" Blade - Hard Surfaced

43	966190	5/8" Lock Washer (pl) Extra Heavy (Supplied with Spindle)
44	966188	2 1/2"OD x 21/32"ID Wash (Supplied with Spndle)
45	966189	5/8" X 1 1/4" Gr.8 Hex Bolt Lck (Supplied with Spindle)
46	811646	1/2" x 6" Hex Bolt (pl)
47	812769	1 1/2" O.D. x 9/16" I.D. x 10ga Washer (pl)
48	902489	1"Ø x 9 1/4" Wheel Yoke Pin
49	9812433	3/16" x 1 1/2" Cotter Pin (pl)
50	902505	1 3/4" x 1 1/4" O.D. Wheel Spacer (pl)
51	967498	1" Slotted Hex Nut NF 14 (pl)
52	966195	Tire & Rim (15 x 6 -6)
53	902422	Wheel Yoke
54	F6651	Tire, Rim, Yoke Assembly
55	902503	1" Long x 1 5/8" O.D. Bushing (pl)
56	902504	1/2" Long x 1 5/8" O.D. Bushing (pl)
57	84000	3/8" B.S. Flat Washer (pl)
58	903834	59" Axle Beam Weldment
59	81570	5/16" B.S. Flat Washer (pl)
60	900750	Side PTO Guard
61	966729	3/16" Linch Pin (pl)
62	81545	1/4" Lock Washer (pl)
63	81544	1/4" Hex Nut (pl)
64	902421	Yoke Shaft 1 1/4" x 9 1/4" Long
65	BU500397-6	5/16" x 5/8" Hex Bolt (pl)
66	81569	5/16" Lock Washer (pl)

4' TRIPLEX HITCH CENTER MOWER DECK

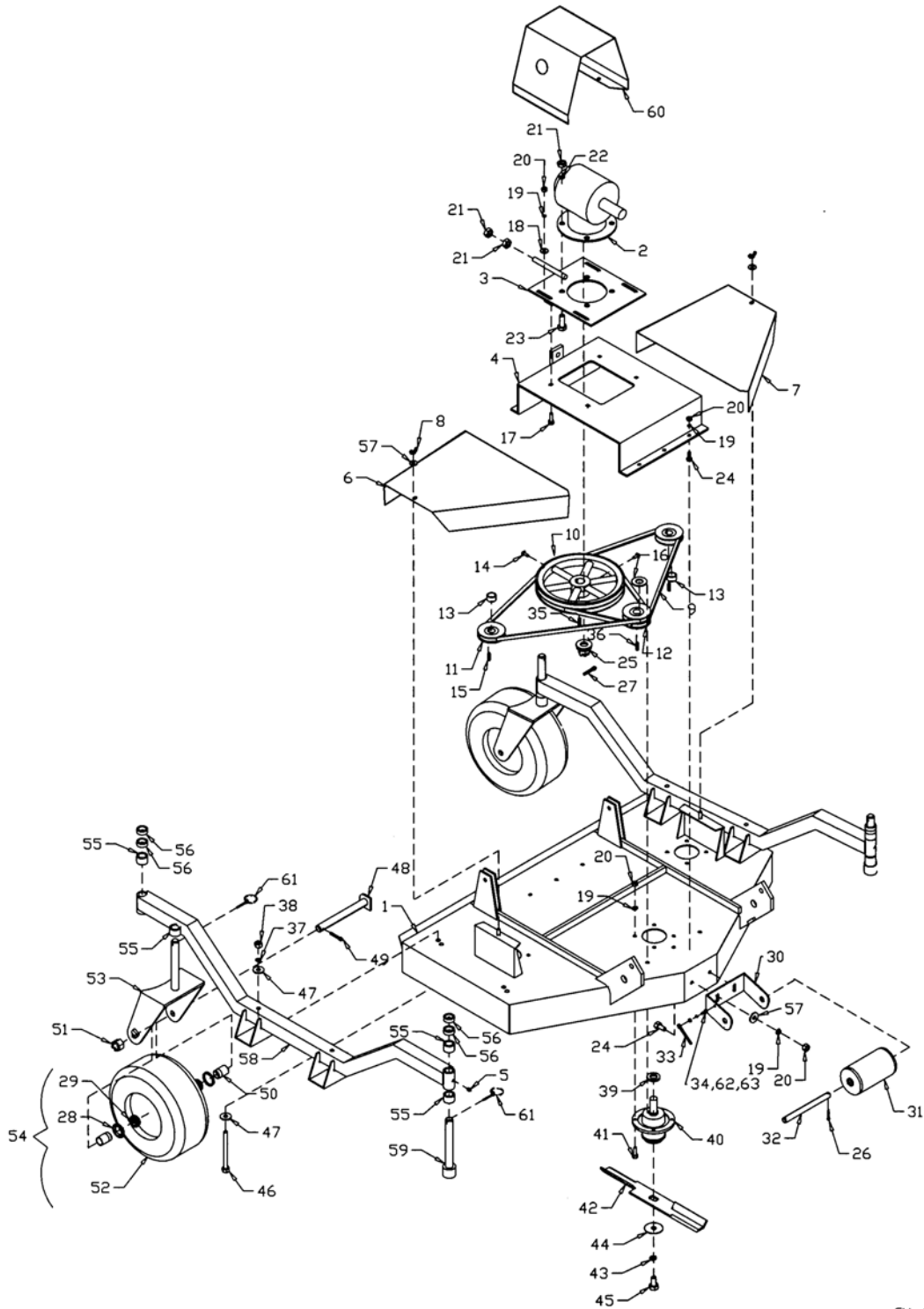

FM-07

4' TRIPLEX CENTER MOWER DECK ASSEMBLY

ITEM	PART#	DESCRIPTION
1	903815	4' Rear Discharge Deck
2	912300158	Gearbox Assembly
3	980004200	Gearbox Base Plate
4	906342	Gearbox Mount Plate
5	967164	Pound-in Grease Nipple (pl)
6	906346	4' R.H. Pulley Guard
7	906347	4' L.H. Pulley Guard
8	84217	3/8" Wing Nut (pl)
9	904250	B-61 Belts
10	966722	12" Double Sheave complete with Set Screws
11	904243	3 3/4" Single Sheave Assy (Machined End Up)
12	904244	3 3/4" Double Sheave complete with Set Screws
13	966811	Sheave Spacer 1 1/4" O.D. x .70"
14	9812377	5/16" x 3/4" Square Head Set Screw (pl)
15	900931	1/4" Square. x 1.11" Key
16	967140	Narrow Rim Washer 1" x 10ga (pl)
17	86182	3/8" x 1 1/4" Carriage Bolt (pl)
18	964001	7/16" I.D. x 10ga Washer (pl)
19	81593	3/8" Lock Washer (pl)
20	81592	3/8" Hex Nut (pl)
21	81676	5/8" Hex Nut (pl)
22	81677	5/8" Lock Washer (pl)
23	84270	5/8" x 1 3/4" Hex Bolt (pl)
24	86170	3/8" x 1" Hex Bolt (pl)
25	905247	Washer & Slotted Hex Nut Weldment Included with Gearbox
26	9812434	1/4" x 1 1/2" Cotter Pin (pl)
27	81207	3/16" x 2" Cotter Pin
28	967497	Oil Seal SE10
29	966776	Bearing Cone (L44643) without Grease
30	903488	Roller Holder
31	903113	Roller Tube Assembly
32	903104	Roller Pin 3/4"Dia x 8 3/4" Long
33	9812436	1/4" x 2 1/2" Cotter Pin (pl)
34	81525	1/4" x 3/4" Hex Bolt (pl)
35	900929	Pulley Key (1/4" Square. x 1 5/8" Long)
36	900930	1/4" x 1 1/2" Key
37	81637	1/2" Lock Washer (pl)
38	81636	1/2" Hex Nut (pl)
39	912301558	1" Snap Ring
40	966860	Spindle with Hardware
41	86171	3/8" x 1 1/4" Hex Bolt (pl)
42	903798	17 3/4" Blade - Hard Surfaced

43	966190	5/8" Lock Washer (pl) Extra Heavy (Supplied with Spindle)
44	966188	2 1/2"OD x 21/32"ID Washer (Supplied with Spindle)
45	966189	5/8" x 1 1/4" Gr.8 Hex Bolt Lock (Supplied with Spindle)
46	811646	1/2" x 6" Hex Bolt (pl)
47	812769	1 1/2" O.D. x 9/16" I.D. x 10ga Washer (pl)
48	902489	1"Ø x 9 1/4" Wheel Yoke Pin
49	9812433	3/16" x 1 1/2" Cotter Pin (pl)
50	902505	1 3/4" x 1 1/4" O.D. Wheel Spacer (pl)
51	967498	1" Slotted Hex Nut NF 14 (pl)
52	966195	Tire & Rim (15 x 6 -6)
53	902422	Wheel Yoke
54	F6651	Tire, Rim, Yoke Assembly
55	902503	1" Long x 1 5/8" O.D. Bushing (pl)
56	902504	1/2" Long x 1 5/8" O.D. Bushing (pl)
57	84000	3/8" B.S. Flat Washer (pl)
58	903834	59" Axle Beam Weldment
59	902421	Yoke Shaft 1 1/4"Ø x 9 1/4" Long
60	966748	PTO Guard
61	966729	3/16" Linch Pin (pl)
62	81545	1/4" Lock Washer (pl)
63	81544	1/4" Hex Nut (pl)

4' TRIPLEX HITCH PTO ASSEMBLY

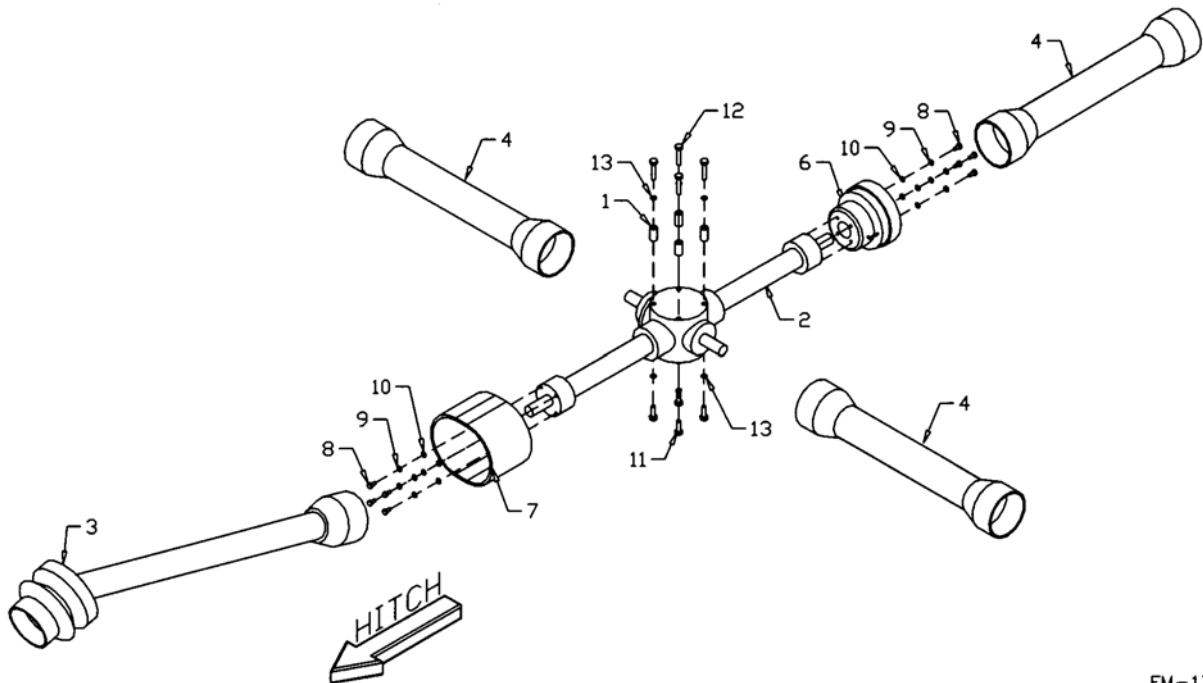

FM-17

4' TRIPLEX HITCH PTO ASSEMBLY

ITEM	PART #	DESCRIPTION
1	903605	Gearbox Spacer 1" O.D. x 1 9/16" Long
2	966300	Gearbox Assembly - BONDI 2050 - without Oil
3	F0692	CV PTO Shaft - BONDIOLI
4	F0405	4' Finishing Mower PTO
6	900748	Rear PTO Guard
7	900749	Front PTO Guard
8	84072	3/8" x 3/4" Hex Bolt (pl)
9	81593	3/8" Lock Washer (pl)
10	84000	3/8" Flat Washer Standard (pl)
11	84277	1/2" x 1 1/2" Hex Bolt (pl)
12	811796	1/2" x 2 1/2" Hex Bolt (pl)
13	81637	1/2" Lock Washer (pl)

5', 6' & 7' TRIPLEX HITCH MAIN FRAME

5' TRIPLEX

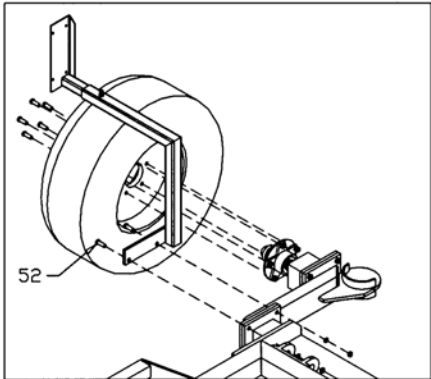

7' TRIPLEX

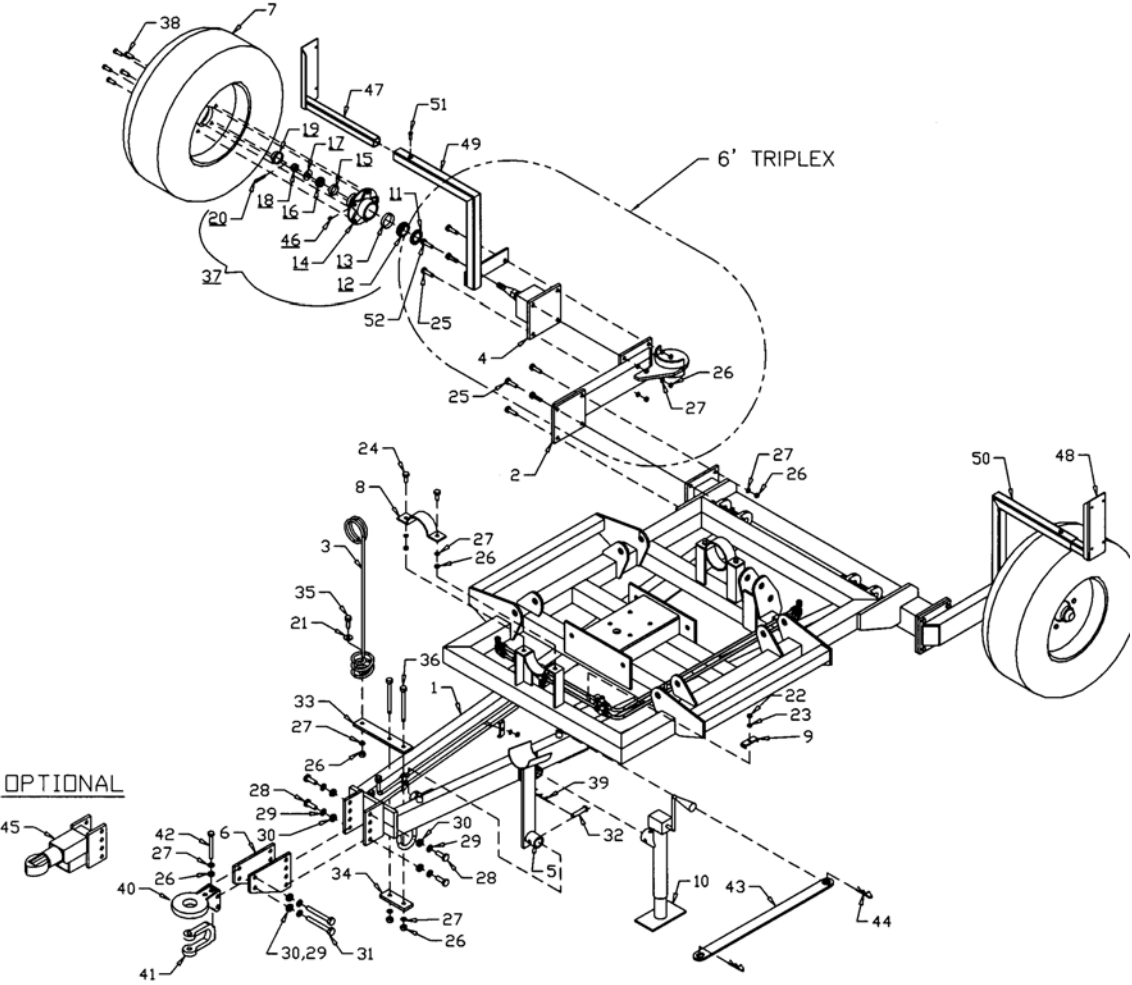
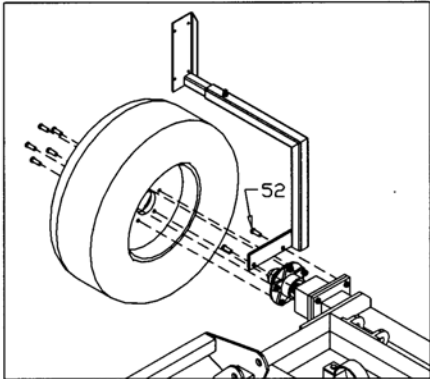

5', 6' & 7' TRIPLEX HITCH MAIN FRAME ASSEMBLY

ITEM	PART #	DESCRIPTION
1	905105	Main Frame Weldment
2	901352	Axle Extension (20") - 5'
	901355	Axle Extension (23 1/2") - 6'
3	966313	Hydraulic Hose Holder
4	900699	Stub Axle Weldment
5	900730	PTO Holder Weldment
6	905027	Hitch Side Plate (Standard)
7	966302	Tire 27 x 10.5 x 15
	966303	Wheel 15" x 8" x 5 Bolt
8	901480	Gearbox Clamp
9	11362	Clip Pipe Standard
10	960327	Jack Assembly
11	968430	Oil Seal (SE 14X)
12	967208	Inner Cone (LM48548)
13	968412	Inner Cup (LM48510)
14	968403	Hub with Bearing Cups (H516)
15	968405	Outer Cup (LM11910)
16	968406	Outer Cone (LM11949)
17	84050	3/4" S.A.E. Flat Washer (pl)
18	81834	3/4" Slotted Hex Nut (br)
19	968409	Dust Cap (DC12)
20	9812486	1/8" x 1 1/2" Cotter Pin
21	81638	1/2" Flat Washer (pl)
22	81592	3/8" Hex Nut (pl)
23	81593	3/8" Lock Washer (pl)
24	81620	1/2" x 1 1/4" Hex Bolt (pl)
25	87553	1/2" x 1 3/4" Hex Bolt (pl)
26	81636	1/2" Hex Nut (pl)
27	81637	1/2" Lock Washer (pl)
28	84270	5/8" x 1 3/4" Hex Bolt (pl)
29	81677	5/8" Lock Washer (pl)
30	81676	5/8" Hex Nut (pl)
31	81673	5/8" x 5" Hex Bolt (pl)
32	900712	PTO Stand Pin 5/8"Dia.. x 3" Long
33	905030	Pigtail Bracket 1/2" x 2" x 11 3/8"
34	905031	Pigtail Bracket 1/2" x 2" x 5 1/2"
35	84277	1/2" x 1 1/2" Hex Bolt (pl)
36	811646	1/2" x 6" Hex Bolt (pl)
37	968431	Hub Assembly
38	968404	1/2" x 1 1/4" Wheel Bolt (pl)
39	961012	#16 Hair Pin Clip (pl)
40	905040	Hitch Base

41	905041	Clevis Bolt-On
42	811691	1/2" x 4 1/2" Hex Bolt (pl)
43	905034	Wing Transport Arm 30 5/8" (5' & 6')
	905155	Wing Transport Arm 31 5/8" (7')
44	12779	Hair Pin Clip #9 Western Wire
45	905036	Hitch Connector Weldment - (Optional)
46	967900	1/4" Grease Fitting
47	909693	Light Bracket Weldment - Right
48	909694	Light Bracket Weldment - Left
49	909691	Hitch Bracket Weldment - Right
50	909692	Hitch Bracket Weldment - Left
51	81213	3/8" x 1" Square Head Setscrew (pl)
52	81624	1/2" x 2 1/4" Hex Bolt (pl)

5', 6' & 7' TRIPLEX HITCH SIDE WING ASSEMBLY

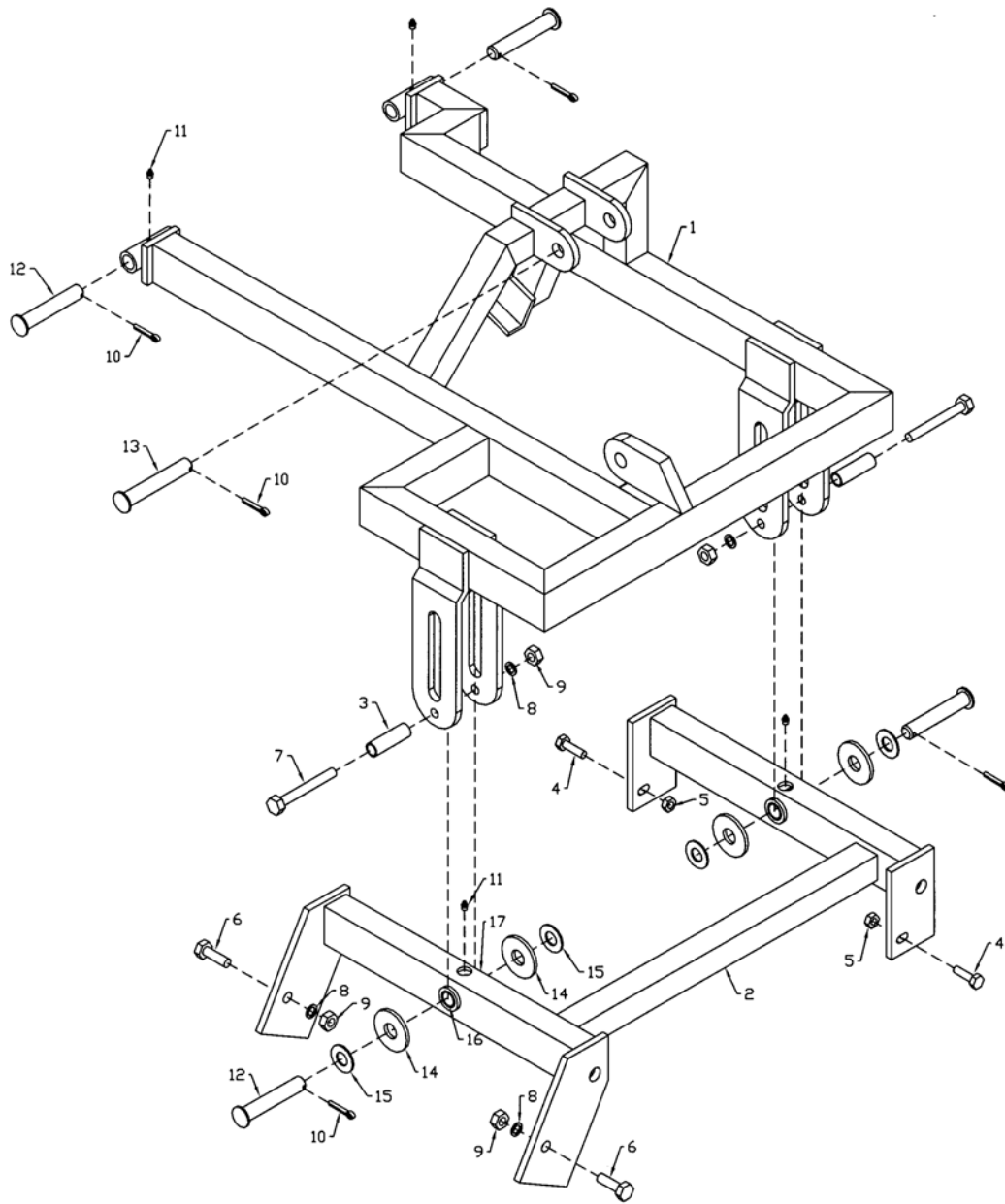

FM-14

5',6' & 7' TRIPLEX HITCH SIDE WING ASSEMBLY

ITEM	PART #	DESCRIPTION
1	901220	5' Left Hand Side Wing Weldment
	901221	5' Right Hand Side Wing Weldment
	900348	6' Left Hand Side Wing Weldment
	901403	6' Right Hand Side Wing Weldment
	901222	7' Left Hand Side Wing Weldment
	900201	7' Right Hand Side Wing Weldment
2	900650	5' Left Hand Deck Mount Weldment
	900651	5' Right Hand Deck Mount Weldment
	900652	6' Left Hand Deck Mount Weldment
	900653	6' Right Hand Deck Mount Weldment
	901207	7' Left Hand Deck Mount Weldment
	901208	7' Right Hand Deck Mount Weldment
3	900735	Deck Spacer 1" O.D. x 3 1/8" Long
4	87553	1/2" x 1 3/4" Hex Bolt (pl)
5	812364	1/2" Lock Nut (pl)
6	84299	5/8" x 2" Hex Bolt (pl)
7	81673	5/8" x 5" Hex Bolt (pl)
8	81677	5/8" Lock Washer (pl)
9	81676	5/8" Hex Nut (pl)
10	9812434	1/4" x 1 1/2" Cotter Pin (pl)
11	967164	Pound-In Grease Nipple
12	901399	Pin 1"Dia. x 5 5/8" Long
13	900709	Pin 1"Dia. x 6 1/8" Long (latch)
14	902411	Wear Washer 3" x 1/4" Thick
15	84522	1" Flat Washer S.A.E. BS (pl)
16	113577	Bushing 1" I.D. x 1 1/4" O.D. x 1 3/8" Long
17	113780	Bushing 1" I.D. x 1 1/4" O.D. x 0.88" Long

5', 6' & 7' TRIPLEX HITCH REAR WING ASSEMBLY

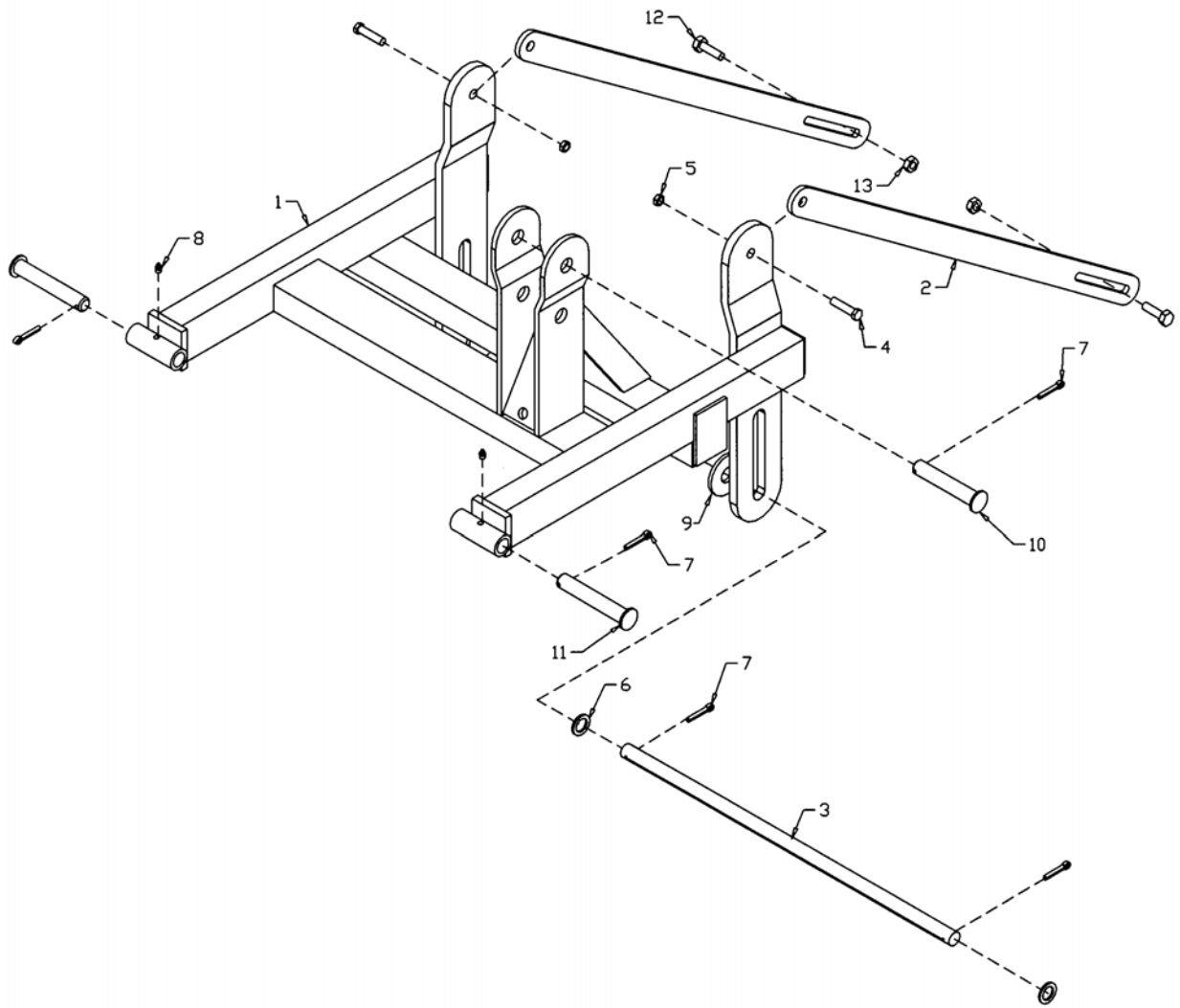

FM-16

5',6' & 7' TRIPLEX HITCH REAR WING ASSEMBLY

ITEM	PART #	DESCRIPTION
1	901168	Rear Wing Weldment
2	900661	5' Pivot Bar 38 1/2" Long
	900662	6' Pivot Bar 44 1/2" Long
	901158	7' Pivot Bar 49 1/2" Long
3	900703	Rear Wing Bar 1" x 29 3/8"
4	84299	5/8" x 2" Hex Bolt (pl)
5	812482	5/8" Lock Nut (pl)
6	84522	1" S.A.E. Flat Washer (pl)
7	9812434	1/4" x 1 1/2" Cotter Pin (pl)
8	967164	Pound-In Grease Nipple
9	902411	Wear Washer 3" x 1/4" Thick
10	901399	Pin 1"Dia. x 5 5/8" Long (Latch)
11	900709	Pin 1"Dia. x 6 1/8" Long (Wing)
12	87553	1/2" x 1 3/4" Hex Bolt (pl)
13	812364	1/2" Lock Nut (pl)

5', 6' & 7' TRIPLEX HITCH LATCH ASSEMBLY

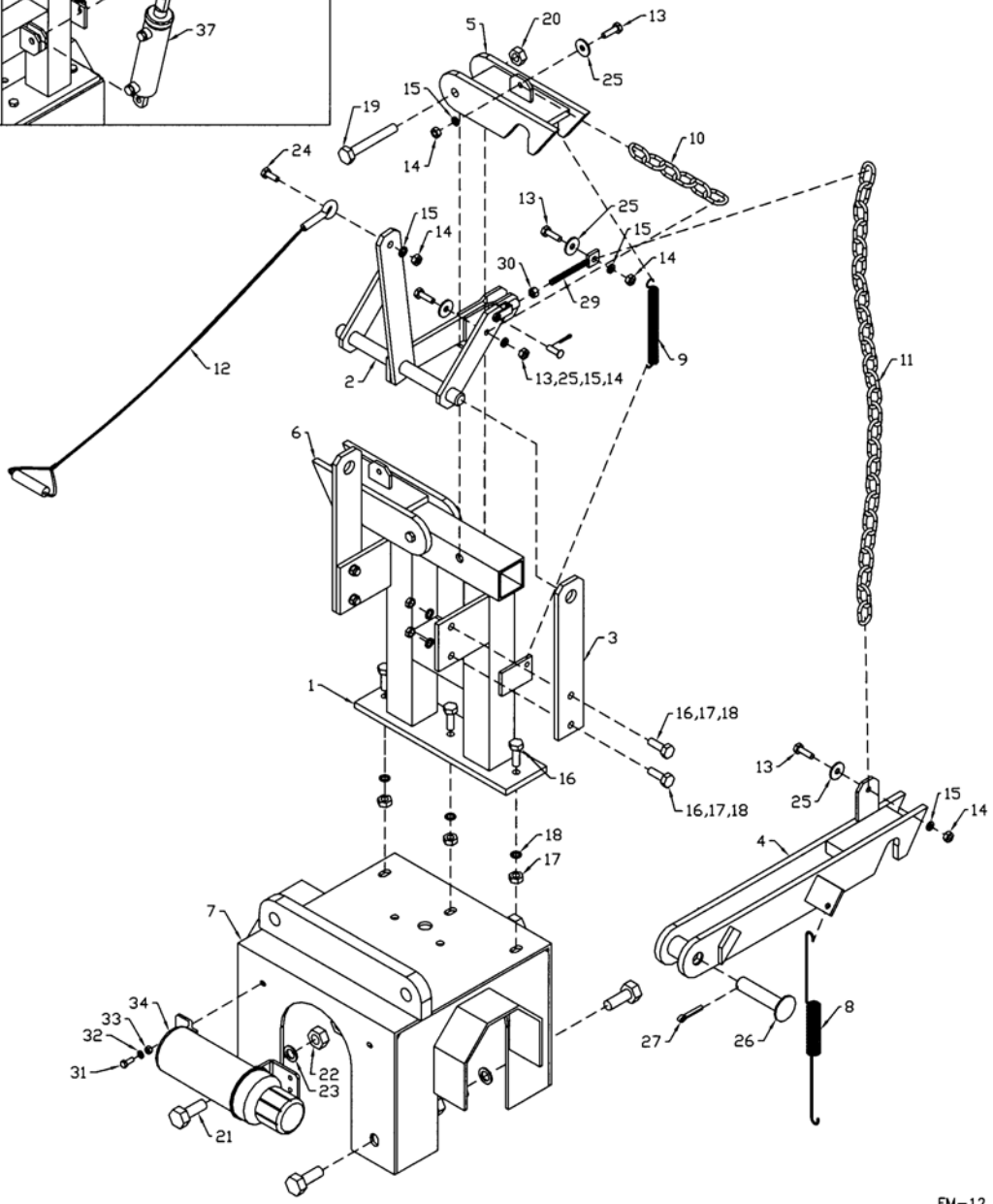
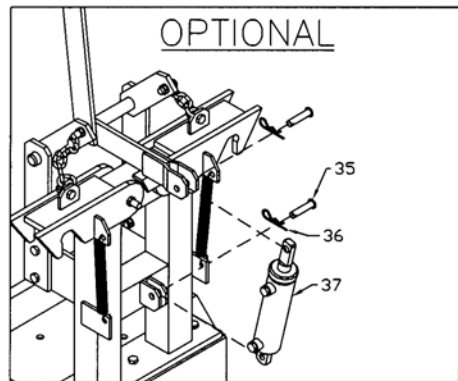

FM-12

5',6' & 7' TRIPLEX HITCH LATCH ASSEMBLY

ITEM	PART #	DESCRIPTION
1	901361	Latch Stand Weldment
2	901369	Latch Weldment
3	901377	Rod Support 3/8" x 2 1/2" x 13"
4	901376	Rear Latch Weldment
5	901373	Left Hand Side Latch
6	901432	Right Hand Side Latch
7	901223	Gearbox Cover Weldment
8	973618	Rear Latch Spring
9	960750	Side Latch Spring
10	966591	1/4" x 6 Link Chain
11	905315	1/4" x 26 Link Chain
12	966311	1/8" x 12' Latch Cable Assembly
13	86171	3/8" x 1 1/4" Hex Bolt (pl)
14	81592	3/8" Hex Nut (pl)
15	81593	3/8" Lock Washer (pl)
16	84277	1/2" x 1 1/2" Hex Bolt (pl)
17	81636	1/2" Hex Nut (pl)
18	81637	1/2" Lock Washer (pl)
19	81672	5/8" x 4 1/2" Hex Bolt (pl)
20	812482	5/8" Lock Nut (pl)
21	84467	3/4" x 2" Hex Bolt (pl)
22	81700	3/4" Hex Nut (pl)
23	81701	3/4" Lock Washer (pl)
24	86170	3/8" x 1" Hex Bolt (pl)
25	84000	3/8" Flat Washer (pl)
26	900705	1" x 4 1/2" Pin Weldment
27	9812434	1/4" x 1 1/2" Cotter Pin (pl)
28	905043	Clevis Yoke with Clevis Pin (H.Paulin AY28)
29	903590	Chain Tightener Rod Weldment
30	8175	3/8" Hex Nut NF (pl)
31	812026	5/16" x 1" Hex Bolt (pl)
32	81569	5/16" Lock Washer (pl)
33	81568	5/16" Hex Nut (pl)
34	909277	Manual Holder
35	961010	1/2" X 2 1/8" Clevis Pin (pl)
36	12779	Hair Pin Clip #9
37	24930	1 3/4" x 5" Cylinder

5', 6' & 7' TRIPLEX HITCH HYDRAULIC ASSEMBLY

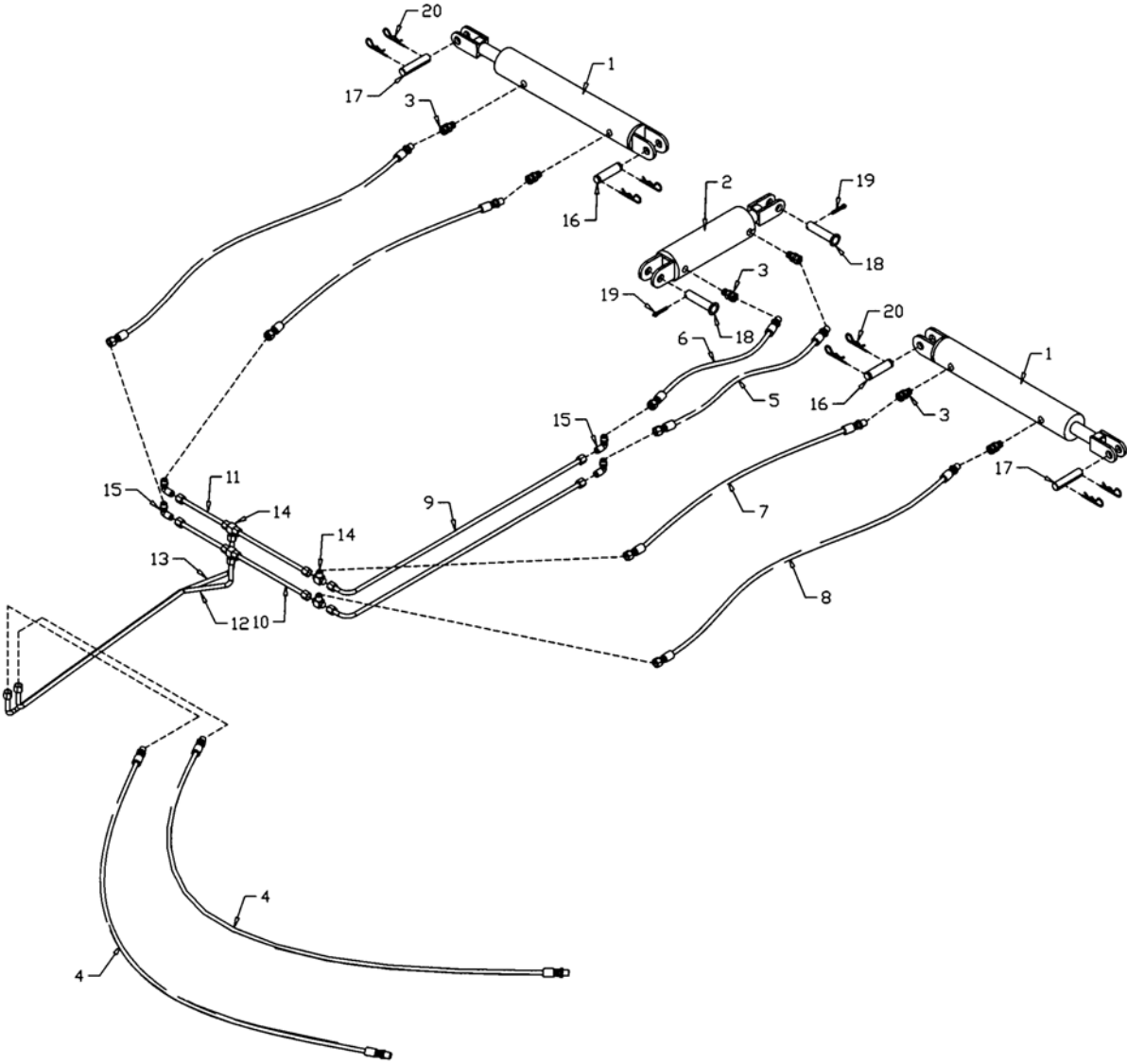

FM-20

5',6' & 7' TRIPLEX HITCH HYDRAULIC ASSEMBLY

ITEM	PART #	DESCRIPTION
1	24789	Cylinder 3" x 20" Stroke
2	24803	Cylinder 3 1/2" x 8" Stroke
3	966321	Adaptor S01120-8D x .052
4	812861	1/2" NPT x 84" Hose 1/2 MNPT x 3/4 MJIC
5	114780	1/2" NPT x 24" Hose 1/2 MNPT x 3/4 SWFJIC
6	114781	1/2" NPT x 18" Hose 1/2 MNPT x 3/4 SWFJIC
7	114782	1/2" NPT x 34" Hose 1/2 MNPT x 3/4 SWFJIC
8	114783	1/2" NPT x 54" Hose 1/2 MNPT x 3/4 SWFJIC
9	114759	Triplex Hydraulic Line - 40"
10	903078	Left Hydraulic Line - 11"
11	903079	Right Hydraulic Line - 7"
12	905044	Hitch Hydraulic Line - 39"
13	905045	Hitch Hydraulic Line - 42"
14	812069	Tee 3/4 MJIC
15	812128	Elbow 90 3/4 MJIC x 3/4 MJIC
16	103753	Cylinder Clevis Pin 1" Dia. x 4"
17	905038	Pin 1" x 4 3/8" (3 Holes)
18	900705	Pin Weldment 1" x 4 1/2"
19	9812434	1/4" x 1 1/2" Cotter Pin (pl)
20	12779	Hair Pin Clip #9 Western Wire

5', 6' & 7' TRIPLEX HITCH SIDE MOWER DECK

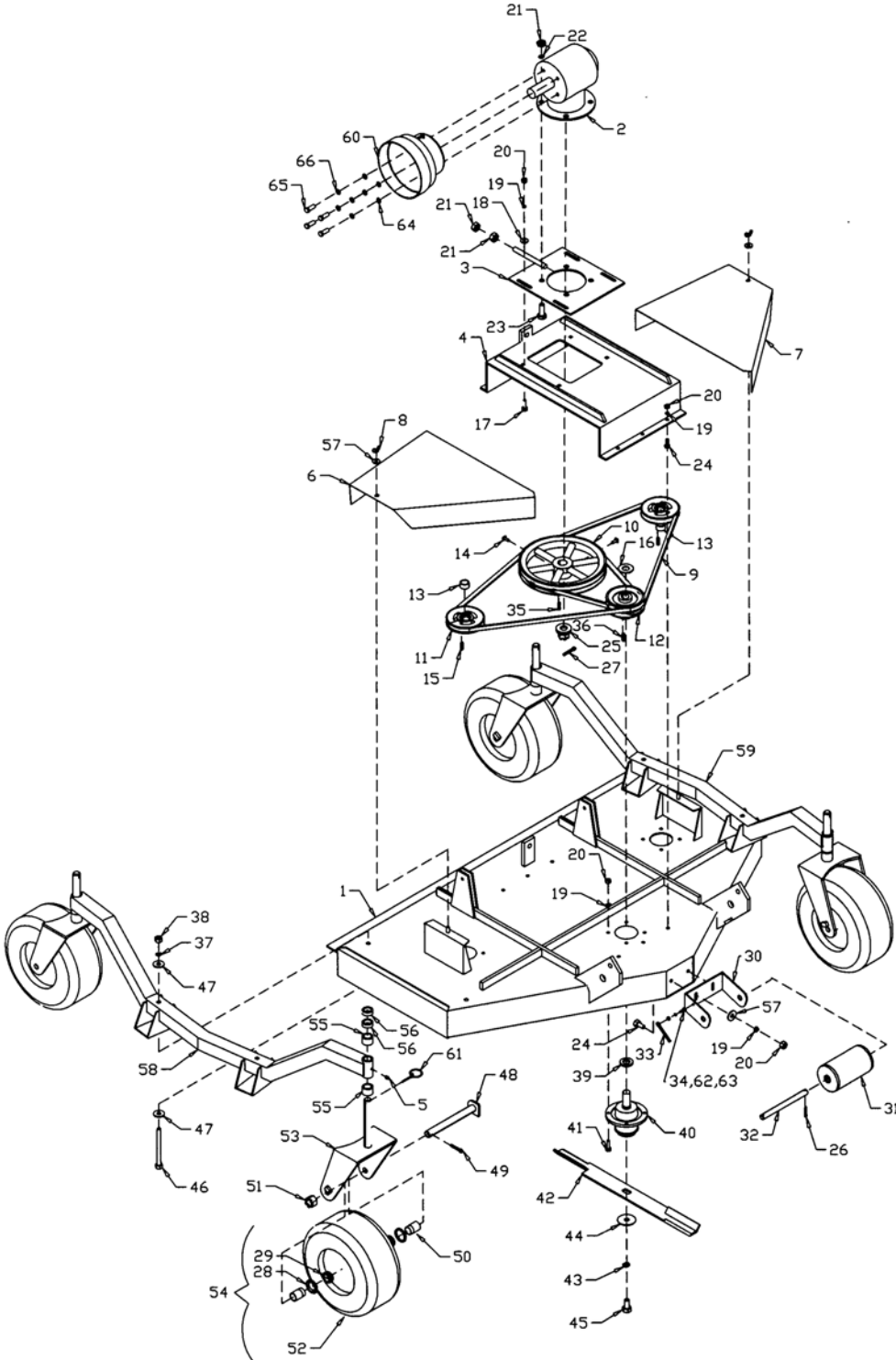

FM-06

5',6' & 7' TRIPLEX SIDE MOWER DECK ASSEMBLY

ITEM	PART#	DESCRIPTION
1	902667	5' Rear Discharge Deck
	902668	6' Rear Discharge Deck
	902669	7' Rear Discharge Deck
2	912300158	Gearbox Assembly
3	980004200	Gearbox Base Plate
4	906343	Gearbox Mount Plate
5	967164	Pound-in Grease Nipple
6	906353	5' Right hand Pulley Guard
	906355	6' Right hand Pulley Guard
	902269	7' Right hand Pulley Guard
7	906354	5' Left hand Pulley Guard
	906356	6' Left hand Pulley Guard
	902268	7' Left hand Pulley Guard
8	84217	3/8" Wing Nut (pl)
9	904251	B-70 Belts (5')
	973506	B-78 Belts (6')
	973248	B-87 Belts (7')
10	966722	12" Double Sheave complete with Set Screws
11	904245	4 1/2" Single Sheave Assy (Machined End Up) (5' & 6')
	904247	5 1/4" Single Sheave Assy (Machined End Up) (7')
12	904246	4 1/2" Double Sheave complete with Set Screws (5' & 6')
	904248	5 1/4" Double Sheave complete with Set Screws (7')
13	966811	Sheave Spacer 1 1/4" O.D. x .70"
14	9812377	5/16" x 3/4" Square Head Set Screw (pl)
15	900931	1/4" Square x 1.11" Key
16	967140	Narrow Rim Washer 1" x 10ga (pl)
17	86182	3/8" x 1 1/4" Carriage Bolt (pl)
18	964001	7/16" I.D. x 10ga Washer (pl)
19	81593	3/8" Lock Washer (pl)
20	81592	3/8" Hex Nut (pl)
21	81676	5/8" Hex Nut (pl)
22	81677	5/8" Lock Washer (pl)
23	84270	5/8" x 1 3/4" Hex Bolt (pl)
24	86170	3/8" x 1" Hex Bolt (pl)
25	905247	Washer & Slotted Hex Nut Weldment Included with Gearbox
26	9812434	1/4" x 1 1/2" Cotter Pin (pl)
27	81207	3/16" x 2" Cotter Pin
28	967497	Oil Seal SE10
29	966776	Bearing Cone (L44643) without Grease
30	903488	Roller Holder
31	903113	Roller Tube Assembly
32	903104	Roller Pin 3/4"Dia x 8 3/4" Lg

33	9812436	1/4" x 2 1/2" Cotter Pin (pl)
34	81525	1/4" x 3/4" Hex Bolt (pl)
35	900929	Pulley Key (1/4" Square x 1 5/8" Long)
36	900930	1/4" x 1 1/2" Key
37	81637	1/2" Lock Washer (pl)
38	81636	1/2" Hex Nut (pl)
39	912301558	1" Snap Ring
40	966860	Spindle with Hardware
41	86171	3/8" x 1 1/4" Hex Bolt (pl)
42	966273	21 3/4" Blade (5') - Hard Surfaced
	966274	25 3/4" Blade (6') - Hard Surfaced
	966167	29 3/4" Blade (7') - Hard Surfaced
43	966190	5/8" Lock Wash (pl) Extra Heavy (Supplied with Spindle)
44	966188	2 1/2"OD x 21/32"ID Wash (Supplied with Spindle)
45	966189	5/8" X 1 1/4" Gr.8 Hex Bolt Lck (Supplied with Spindle)
46	811646	1/2" x 6" Hex Bolt (pl)
47	812769	1 1/2" O.D. x 9/16" I.D. x 10ga Washer (pl)
48	902489	1"Ø x 9 1/4" Wheel Yoke Pin
49	9812433	3/16" x 1 1/2" Cotter Pin (pl)
50	902505	1 3/4" x 1 1/4" O.D. Wheel Spacer (pl)
51	967498	1" Slotted Hex Nut NF 14 (pl)
52	966195	Tire & Rim (15 x 6 -6)
53	902422	Wheel Yoke
54	F6651	Tire, Rim, Yoke Assembly
55	902503	1" Long x 1 5/8" O.D. Bushing (pl)
56	902504	1/2" Long x 1 5/8" O.D. Bushing (pl)
57	84000	3/8" B.S. Flat Washer (pl)
58	902425	62 1/2" Right Axle Beam Weldment (5')
	902427	67 1/2" Right Axle Beam Weldment (6')
	902433	69 1/2" Right Axle Beam Weldment (7')
59	902425	62 1/2" Left Axle Beam Weldment (5')
	902427	67 1/2" Left Axle Beam Weldment (6')
	902433	69 1/2" Left Axle Beam Weldment (7')
60	900750	Side PTO Guard
61	966729	3/16" Linch Pin (pl)
62	81545	1/4" Lock Washer (pl)
63	81544	1/4" Hex Nut (pl)
64	81570	5/16" B.S. Flat Washer (pl)
65	BU500397-6	5/16" x 5/8" Hex Bolt (pl)
66	81569	5/16" Lock Washer (pl)

5', 6' & 7' TRIPLEX HITCH CENTER MOWER DECK

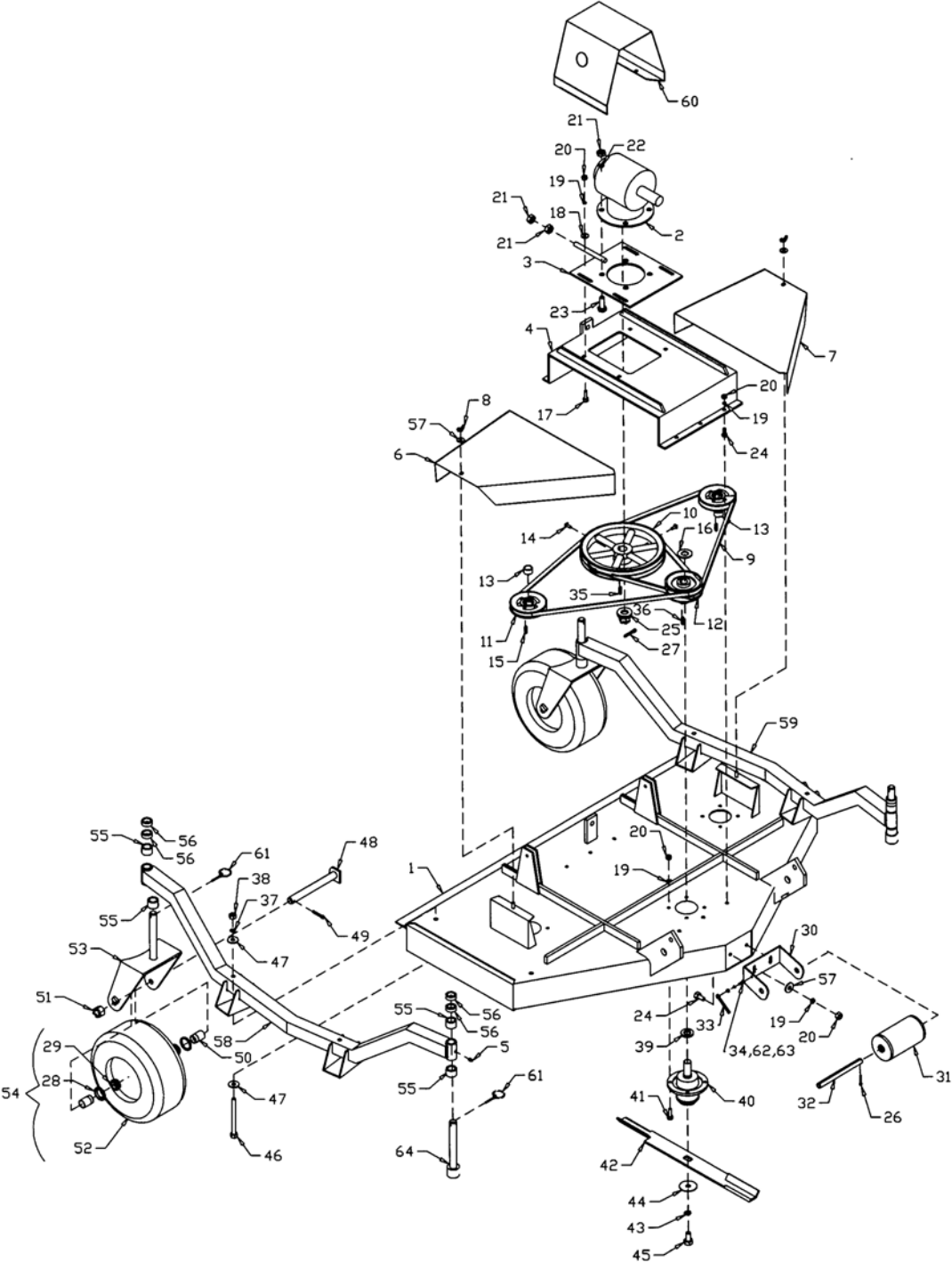

FM-08

5',6' & 7' TRIPLEX CENTER MOWER DECK ASSEMBLY

ITEM	PART#	DESCRIPTION
1	902667	5' Rear Discharge Deck
	902668	6' Rear Discharge Deck
	902669	7' Rear Discharge Deck
2	912300158	Gearbox Assembly
3	980004200	Gearbox Base Plate
4	906343	Gearbox Mount Plate
5	967164	Pound-in Grease Nipple (pl)
6	906353	5' Right hand Pulley Guard
	906355	6' Right hand Pulley Guard
	902269	7' Right hand Pulley Guard
7	906354	5' Left hand Pulley Guard
	906356	6' Left hand Pulley Guard
	902268	7' Left hand Pulley Guard
8	84217	3/8" Wing Nut (pl)
9	904251	B-70 Belts (5')
	973506	B-78 Belts (6')
	973248	B-87 Belts (7')
10	966722	12" Double Sheave complete with Set Screws
11	904245	4 1/2" Single Sheave Assembly (Machined End Up) (5' & 6')
	904247	5 1/4" Single Sheave Assembly (Machined End Up) (7')
12	904246	4 1/2" Double Sheave complete with Set Screws (5' & 6')
	904248	5 1/4" Double Sheave complete with Set Screws (7')
13	966811	Sheave Spacer 1 1/4" O.D. x .70"
14	9812377	5/16" x 3/4" Square Head Set Screw (pl)
15	900931	1/4" Square x 1.11" Key
16	967140	Narrow Rim Washer 1" x 10ga (pl)
17	86182	3/8" x 1 1/4" Carriage Bolt (pl)
18	964001	7/16" I.D. x 10ga Washer (pl)
19	81593	3/8" Lock Washer (pl)
20	81592	3/8" Hex Nut (pl)
21	81676	5/8" Hex Nut (pl)
22	81677	5/8" Lock Washer (pl)
23	84270	5/8" x 1 3/4" Hex Bolt (pl)
24	86170	3/8" x 1" Hex Bolt (pl)
25	905247	Washer & Slotted Hex Nut Weldment Included with Gearbox
26	9812434	1/4" x 1 1/2" Cotter Pin (pl)
27	81207	3/16" x 2" Cotter Pin
28	967497	Oil Seal SE10
29	966776	Bearing Cone (L44643) with out Grease
30	903488	Roller Holder
31	903113	Roller Tube Assembly
32	903104	Roller Pin 3/4"Dia x 8 3/4" Long

33	9812436	1/4" x 2 1/2" Cotter Pin (pl)
34	81525	1/4" x 3/4" Hex Bolt (pl)
35	900929	Pulley Key (1/4" Square x 1 5/8" Long)
36	900930	1/4" x 1 1/2" Key
37	81637	1/2" Lock Washer (pl)
38	81636	1/2" Hex Nut (pl)
39	912301558	1" Snap Ring
40	966860	Spindle with Hardware
41	86171	3/8" x 1 1/4" Hex Bolt (pl)
42	966273	21 3/4" Blade (5') - Hard Surfaced
	966274	25 3/4" Blade (6') - Hard Surfaced
	966167	29 3/4" Blade (7') - Hard Surfaced
43	966190	5/8" Lock Wash (pl) Extra Heavy (Supplied with Spindle)
44	966188	2 1/2"OD x 21/32"ID Washer (Supplied with Spindle)
45	966189	5/8" x 1 1/4" Gr.8 Hex Bolt Lock (Supplied with Spindle)
46	811646	1/2" x 6" Hex Bolt (pl)
47	812769	1 1/2" O.D. x 9/16" I.D. x 10ga Washer (pl)
48	902489	1"Dia. x 9 1/4" Wheel Yoke Pin
49	9812433	3/16" x 1 1/2" Cotter Pin (pl)
50	902505	1 3/4" x 1 1/4" O.D. Wheel Spacer (pl)
51	967498	1" Slotted Hex Nut NF 14 (pl)
52	966195	Tire & Rim (15 x 6 -6)
53	902422	Wheel Yoke
54	F6651	Tire, Rim, Yoke Assembly
55	902503	1" Long x 1 5/8" O.D. Bushing (pl)
56	902504	1/2" Long x 1 5/8" O.D. Bushing (pl)
57	84000	3/8" B.S. Flat Washer (pl)
58	902425	62 1/2" Right Axle Beam Weldment (5')
	902431	67 1/2" Right Axle Beam Weldment (6')
	902433	69 1/2" Right Axle Beam Weldment (7')
59	902425	62 1/2" Left Axle Beam Weldment (5')
	902430	67 1/2" Left Axle Beam Weldment (6')
	902433	69 1/2" Left Axle Beam Weldment (7')
60	966748	PTO Guard
61	966729	3/16" Linch Pin (pl)
62	81545	1/4" Lock Washer (pl)
63	81544	1/4" Hex Nut (pl)
64	902421	Yoke Shaft 1 1/4"Dia. x 9 1/4" Long (5' & 6')
	902422	Wheel Yoke (7' Only)

5', 6' & 7' TRIPLEX HITCH PTO ASSEMBLY

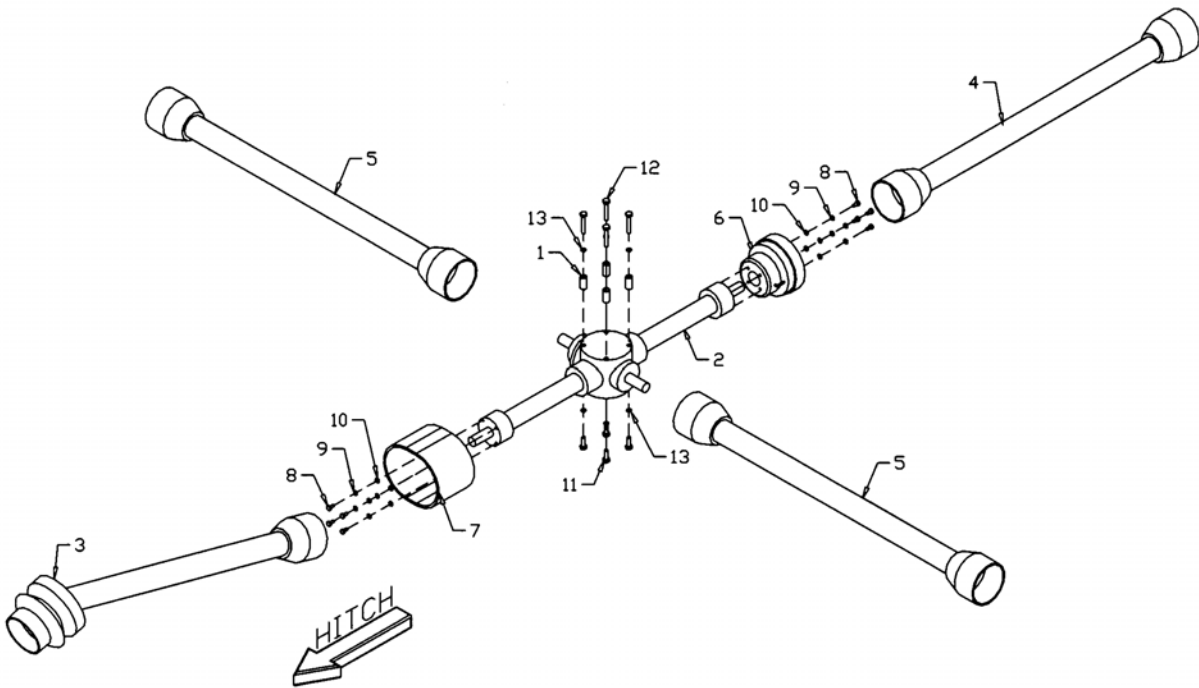

FM-18

5',6' & 7' TRIPLEX HITCH PTO ASSEMBLY

ITEM	PART #	DESCRIPTION
1	900736	Gearbox Spacer 1" O.D. x 1 7/8" Long
2	966300	Gearbox Assembly - BONDIOLI 2050 - without Oil
3	F0693	CV PTO Shaft - BONDIOLI
4	F0404	Rear Mower PTO - 5' & 6'
	F0403	Rear Mower PTO - 7'
5	F0401	Side PTO - 5'
	F0400	Side PTO - 6'
	F0403	Side PTO - 7'
6	900748	Rear PTO Guard
7	900749	Front PTO Guard
8	84072	3/8" x 3/4" Hex Bolt (pl)
9	81593	3/8" Lock Washer (pl)
10	84000	3/8" Standard Flat Washer (pl)
11	84277	1/2" x 1 1/2" Hex Bolt (pl)
12	81627	1/2" x 3" Hex Bolt (pl)
13	81637	1/2" Lock Washer (pl)

FINISHING MOWER SPINDLE ASSEMBLY

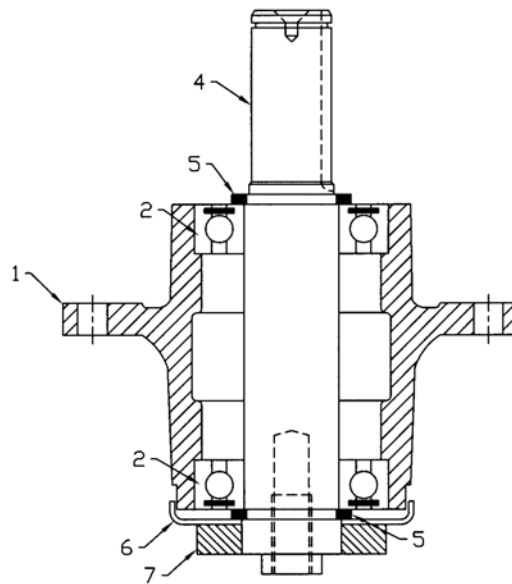
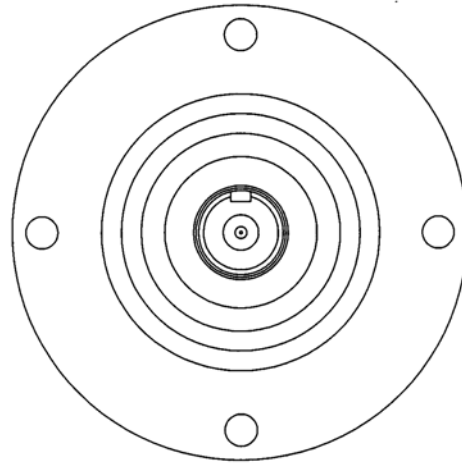

FM-63

FINISHING MOWER SPINDLE PARTS LIST (ALL)

Item #	Part #	Description
	966860	Spindle Assembly Complete (Includes Hardware)
1	966862	Spindle Housing
2	966863	Spindle Bearing (63067)
3	912301558	Snap Ring
4	906394	Spindle Shaft
5	966769	Snap Ring
6	966865	Shield
7	966821	Blade Mount Base

FINISHING MOWER GEARBOX

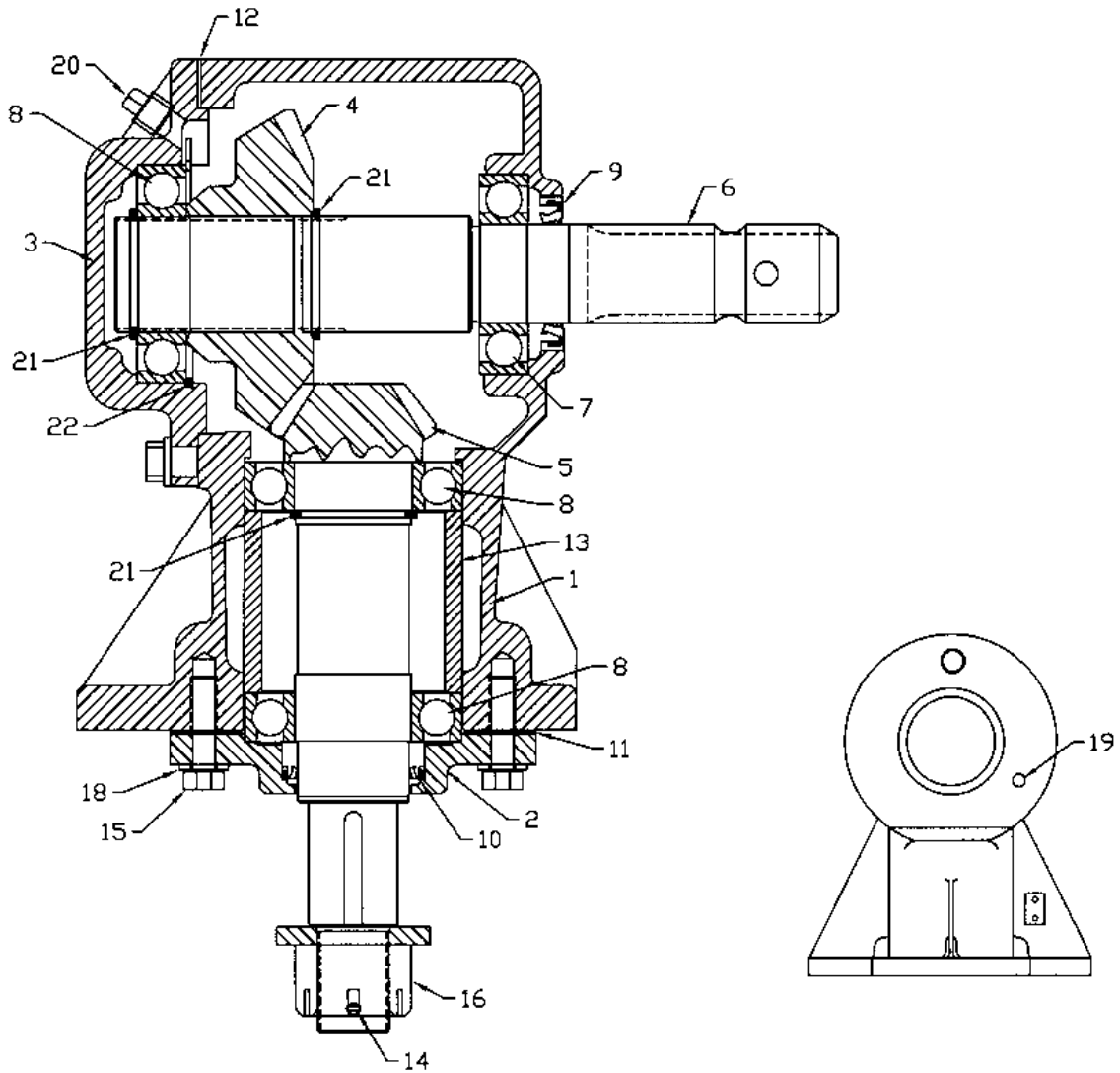

912300158

FINISHING MOWER GEARBOX PARTS LIST

Item #	Part #	Description
	912300158	Gearbox Complete
1	966813	Housing
2	914015	Output Cap
3	966814	Blank Cap
4	966815	Input Gear, 29T
5	966816	Pinion Gear, 15T
6	966817	Input Shaft
7	966542	Ball Bearing, 6207
8	966555	Ball Bearing, 6208
9	966818	Input Seal
10	966819	Output Seal
11	914019	Output Gasket
12	914007	Input Gasket
13	914001	Spacer
14	966562	Cotter Pin
15	86171	3/8" x 1 1/4" Hex Bolt
16	905247	1" NF Hex Nut W/Washer
18	81593	3/8" Lock Washer
19	914016	1/8" Sq. Hd. Solid Plug
20	966193	1/4" Vented Plug
21	914008	Retaining Ring
22	914003	Retaining Ring

TRIPLEX MOWER GEARBOX

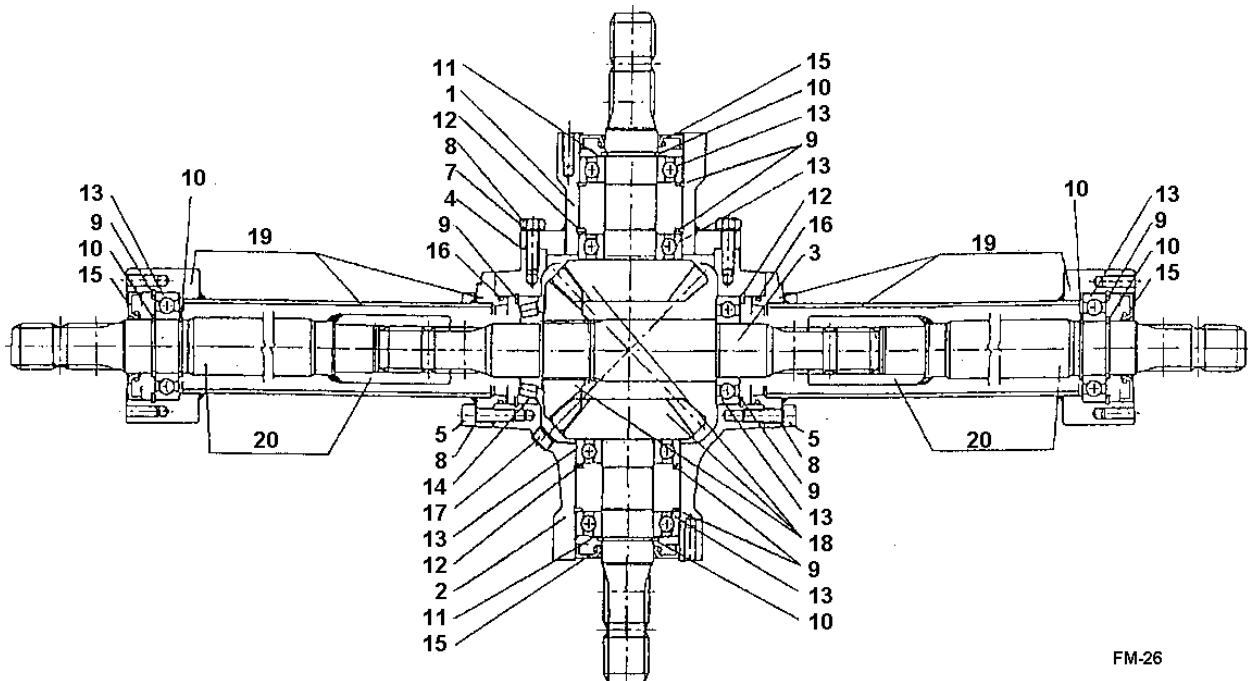

TRIPLEX MOWER GEARBOX PARTS LIST

ITEM	PART#	DESCRIPTION	QTY
	966300	Gearbox Complete	1
1	966030	Hub	1
2	966031	Housing	1
3	966032	Shaft	1
4	966033	Gasket	1
5	966034	Screw	8
6	966035	Screw	5
7	966036	Washer	6
8	966037	Washer	8
9	967305	Snap Ring	8
10	967399	Snap Ring	6
11	966039	Ring	2
12	966040	Ring	3
13	966555	Ball Bearing	7
14	966042	Tapered r. Bearing	1
15	966043	Oil Seal	4
16	966044	Oil Seal	2
17	967312	Oil Plug	3
18	966045	Bevel Gear	1
19	966046	Extension	2
20	966047	Shaft	2

TRIPLEX MAIN CV PTO SHAFT

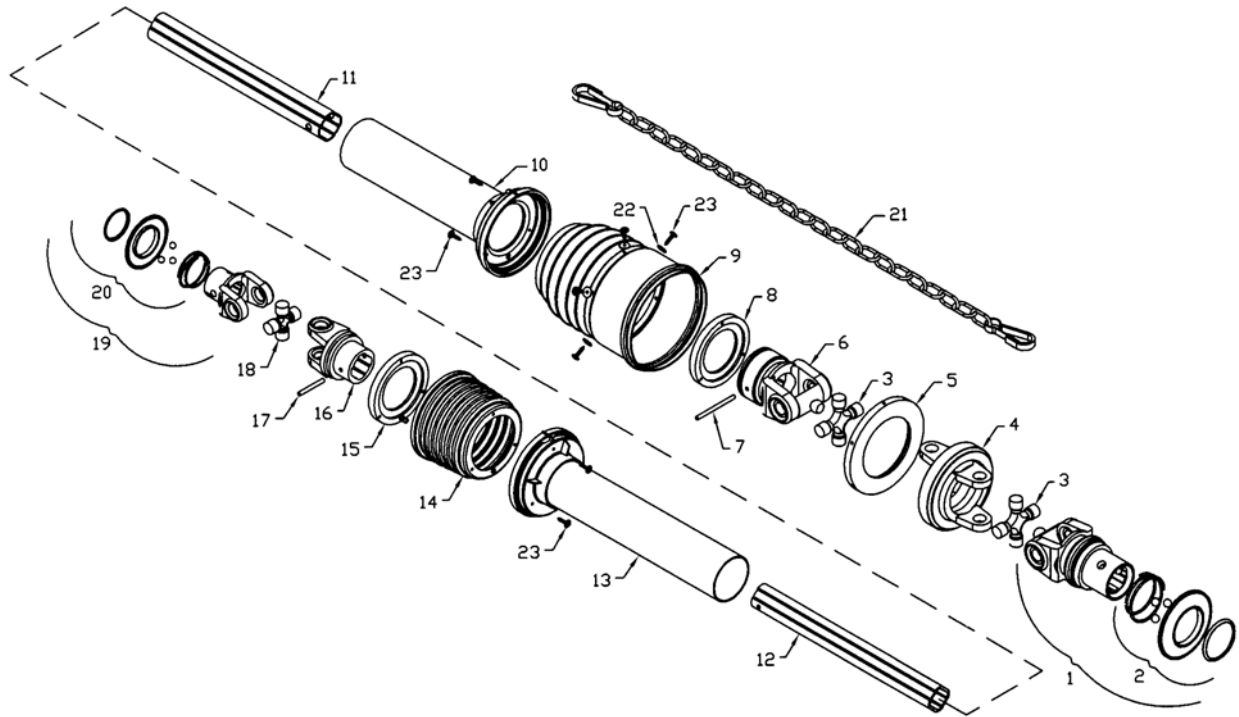

FM-21

4' TRIPLEX MOWER MAIN CV PTO SHAFT

ITEM	PART #	DESCRIPTION
	F0692	Shaft Complete
	909485	Tractor Half of PTO (CV End)
	909486	Implement Half of PTO
	909552	Full Shielding Set
	909550	Tractor Half Shielding
	909551	Implement Half Of Shielding
1	909470	Tractor Yoke With Release
2	909489	Disconnect Repair Kit (CV End Only)
3	909479	Cross Kit (CV End)
4	909472	Central Body
5	909482	Shield Support Ring
6	909471	Outer Cardan Tube Yoke
7	909473	Flexible Roll Pin
8	909481	Shield Support (Outer)
9	909556	Tractor Yoke Shielding Cone
10	909557	Outer Cardan Tube Shielding
11	909474	Outer Cardan Tube
12	909475	Inner Cardan Tube
13	909559	Inner Cardan Tube Shielding
14	909558	Implement Yoke Shielding Cone
15	909473	Shield Support (Inner)
16	909477	Inner Cardan Tube Yoke
17	936351	Flexible Roll Pin
18	909480	Cross Kit (Implement End)
19	909478	Implement Yoke With Release
20	909490	Disconnect Repair Kit (Implement End)
21	909484	Safety Chain
22	909488	Shield Washer
23	909487	Shielding Self Tapping Screw

5',6' & 7' TRIPLEX MOWER MAIN CV PTO SHAFT

ITEM	PART #	DESCRIPTION
	F0693	Shaft Complete
	909505	Tractor Half of PTO (CV End)
	909506	Implement Half of PTO
	909555	Full Shielding Set
	909553	Tractor Half Of Shielding
	909554	Implement Half Of Shielding
1	909491	Tractor Yoke With Release
2	909489	Disconnect Repair Kit (CV End Only)
3	909499	Cross Kit (CV End)
4	909493	Central Body
5	909502	Shield Support Ring
6	909492	Outer Cardan Tube Yoke
7	909494	Flexible Roll Pin
8	909501	Shield Support (Outer)
9	909560	Tractor Yoke Shielding Cone
10	909561	Outer Cardan Tube Shielding
11	909495	Outer Cardan Tube
12	909496	Inner Cardan Tube
13	909563	Inner Cardan Tube Shielding
14	909562	Implement Yoke Shielding Cone
15	909503	Shield Support (Inner)
16	909497	Inner Cardan Tube Yoke
17	910-042	Flexible Roll Pin
18	909500	Cross Kit (Implement End)
19	909498	Implement Yoke With Release
20	909490	Disconnect Repair Kit (Implement End)
21	909504	Safety Chain
22	909488	Shield Washer
23	909487	Shielding Self Tapping Screw

TRIPLEX MOWER PTO SHAFTS (REAR AND SIDES)

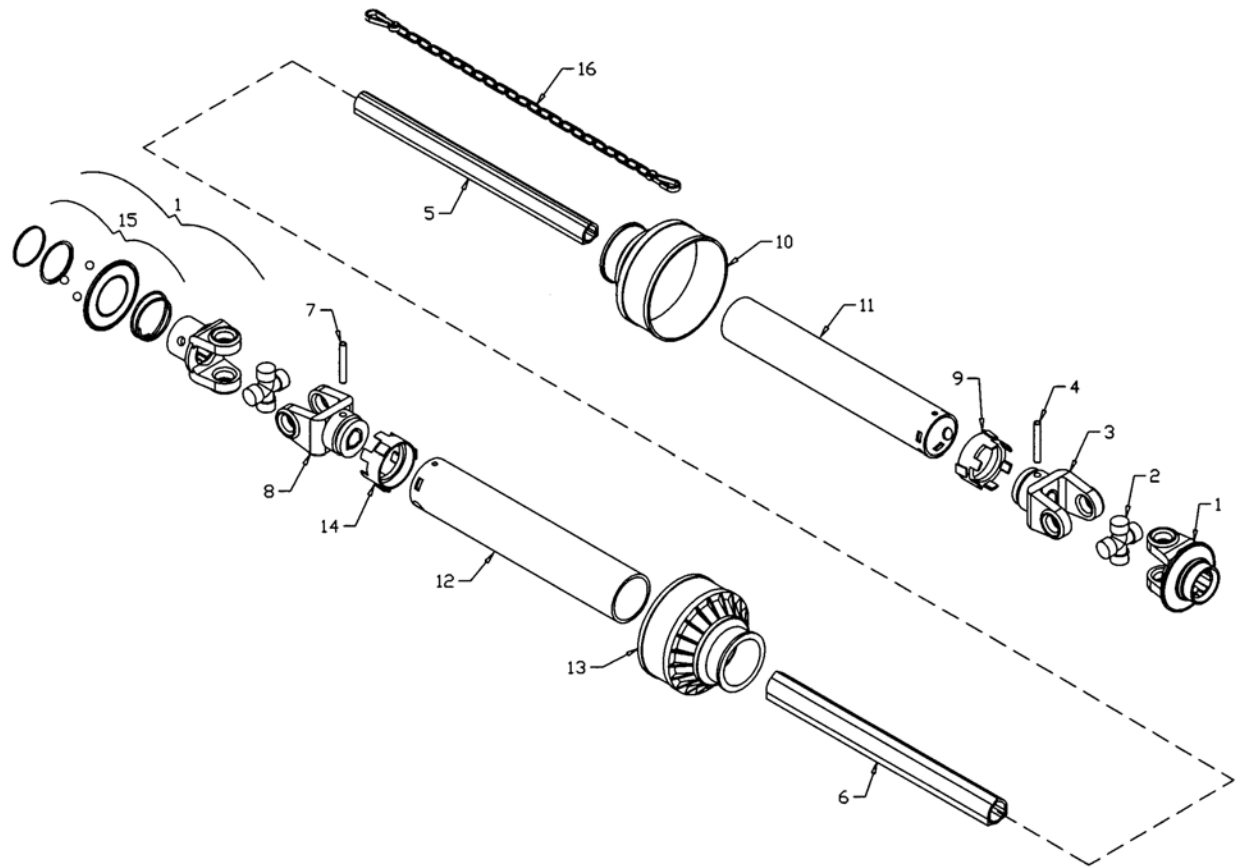

FM-22

4' TRIPLEX MOWER PTO SHAFT PARTS LIST

ITEM	PART #	DESCRIPTION
	F0405	Shaft Complete
	907934	Outer Half of PTO
	907935	Inner Half of PTO
1	907290	Yoke
2	920-002	Repair Kit
3	920-004	Outer Tube Yoke
4	920-006	Flexible Pin
5	936552	Outer Cardan Tube
6	936553	Inner Cardan Tube
7	930-109	Flexible Pin
8	920-003	Inner Tube Yoke
9	920-013	Outer Bearing
10	920-017	Outer Cone Set
11	936554	Outer Safety Tube
12	936555	Inner Safety Tube
13	920-014	Inner Cone Set
14	920-015	Inner Shield Bearing
15	908244	Ball & Collar Kit
16	936402	Safety Chain
		Danger Label on Cardan
Not Illustrated	936444	Tube
		Danger Label on Outer
Not Illustrated	936447	Shield

5' TRIPLEX MOWER PTO SHAFT PARTS LIST (REAR & SIDE)

ITEM	PART #	DESCRIPTION
	F0401	Shaft Complete - Side
	907938	Outer Half of PTO - Side
	907939	Inner Half of PTO - Side
	F0404	Shaft Complete - Rear
	907940	Tractor Half of PTO - Rear
	907941	Implement Half of PTO - Rear
1	907290	Yoke - Side & Rear
2	920-002	Repair Kit - Side & Rear
3	920-004	Outer Tube Yoke - Side & Rear
4	920-006	Flexible Pin - Side & Rear
5	936404	Outer Cardan Tube - Side
	936403	Outer Cardan Tube - Rear
6	936406	Inner Cardan Tube - Side
	936451	Inner Cardan Tube - Rear
7	930-109	Flexible Pin - Side & Rear
8	920-003	Inner Tube Yoke - Side & Rear
9	920-013	Outer Bearing - Side & Rear
10	920-017	Outer Cone Set - Side & Rear
11	936408	Outer Safety Tube - Side
	936452	Outer Safety Tube - Rear
12	936410	Inner Safety Tube - Side
	936453	Inner Safety Tube - Rear
13	920-014	Inner Cone Set - Side & Rear
14	920-015	Inner Shield Bearing - Side & Rear
15	908244	Release Hub - Side & Rear
16	936402	Safety Chain Side & Rear
Not Illustrated	936444	Danger Label on Cardan Tube
Not Illustrated	936447	Danger Label on Outer Shield

6' TRIPLEX MOWER PTO SHAFT PARTS LIST (REAR & SIDE)

ITEM	PART #	DESCRIPTION
	F0400	Shaft Complete - Side
	907942	Outer Half of PTO - Side
	907943	Inner Half of PTO - Side
	F0404	Shaft Complete - Rear
	907940	Tractor Half of PTO - Rear
	907941	Implement Half of PTO - Rear
1	907290	Yoke - Side & Rear
2	920-002	Repair Kit - Side & Rear
3	920-004	Outer Tube Yoke - Side & Rear
4	920-006	Flexible Pin - Side & Rear
5	936403	Outer Cardan Tube - Side
	936403	Outer Cardan Tube - Rear
6	936405	Inner Cardan Tube - Side
	936451	Inner Cardan Tube - Rear
7	930-109	Flexible Pin - Side & Rear
8	920-003	Inner Tube Yoke - Side & Rear
9	920-013	Outer Bearing - Side & Rear
10	920-017	Outer Cone Set - Side & Rear
11	936407	Outer Safety Tube - Side
	936407	Outer Safety Tube - Rear
12	936409	Inner Safety Tube - Side & Rear
13	920-014	Inner Cone Set - Side & Rear
14	920-015	Inner Bearing - Side & Rear
15	908244	Release Hub - Side & Rear
16	936402	Safety Chain Side & Rear
Not Illustrated	936444	Danger Label on Cardan Tube
Not Illustrated	936447	Danger Label on Outer Shield

7' TRIPLEX MOWER PTO SHAFT PARTS LIST (REAR & SIDE)

ITEM	PART #	DESCRIPTION
	F0403	Shaft Complete
	907944	Outer Half of PTO
	907945	Inner Half of PTO
1	907186	Yoke
2	966211	Repair Kit
3	936344	Outer Tube Yoke
4	936350	Flexible Pin
5	936472	Outer Cardan Tube
6	936473	Inner Cardan Tube
7	936351	Flexible Pin
8	936345	Inner Tube Yoke
9	966209	Outer Bearing
10	936475	Outer Cone Set
11	936476	Outer Safety Tube
12	936477	Inner Safety Tube
13	966208	Inner Shield Cone
14	966210	Inner Shield Collar
15	907192	Ball & Collar Kit
16	936402	Safety Chain
Not Illustrated	936444	Danger Label on Cardan Tube
Not Illustrated	936447	Danger Label on Outer Shield

3 x 18 CYLINDER ASSEMBLY

Item #	Part #	Description
	24932	Cylinder Complete
1	24933	Tube Weldment
2	113936	Piston Rod 1.5 Dia
3	X2415	Seal Kit

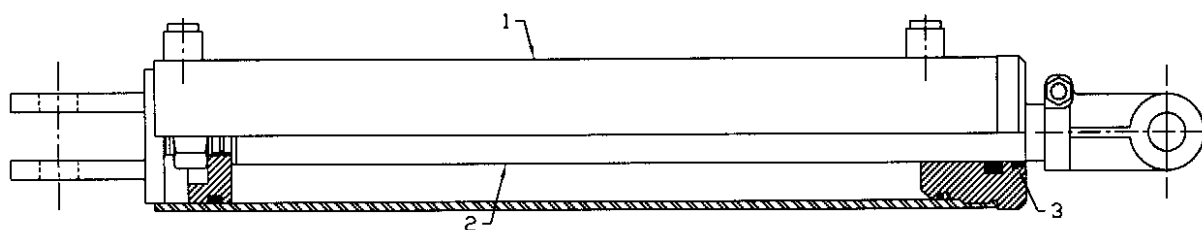

24932

3 x 20 CYLINDER ASSEMBLY

Item #	Part #	Description
	24789	Cylinder Complete
1	24790	Tube Weldment
2	113940	Piston Rod 1.5 Dia
3	X2415	Seal Kit

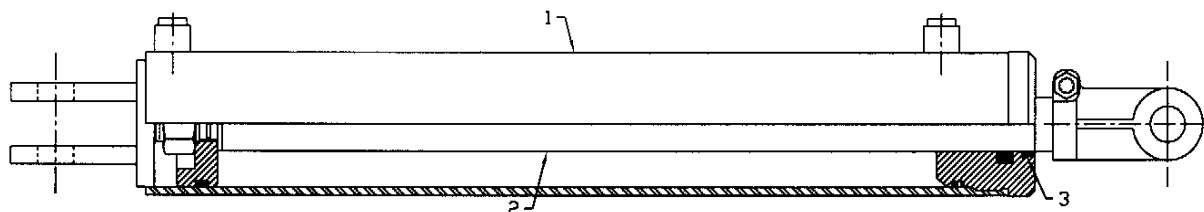

24789

3.5 x 8 CYLINDER ASSEMBLY

Item #	Part #	Description
	24803	Cyl Complete
1	24804	Tube Weldt
2	113934	Piston Rod 1.5 Dia
3	X2098	Seal Kit

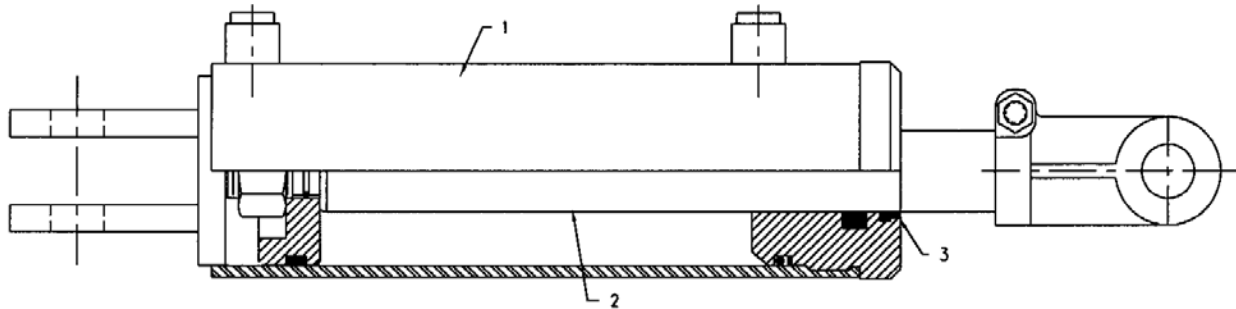

24803

SHIPPING BUNDLES – TRIPLEX MOWERS

	QUANTITY REQUIRED	BUNDLE NUMBER	DESCRIPTION
YT450	2	F6613	15" Wheel & Tire
	1	F0708	Hitch Assembly
	1	F0704	Crate of Parts
Y450TL	1	F450TL	4' L.H. Mower
Y450TC	1	F450TC	4' Center Mower
Y450TR	1	F450TR	4' R.H. Mower
YT550	1	F0709	Hitch Assembly
	2	F6613	15" Wheel & Tire
	1	F0705	Crate of Parts
Y550TL	1	F550TL	5' L.H. Mower
Y550TC	1	F550TC	5' Center Mower
Y550TR	1	F550TR	5' R.H. Mower
YT650	1	F0710	Hitch Assembly
	2	F6613	15" Wheel & Tire
	1	F0706	Crate of Parts
Y650TL	1	F650TL	6' L.H. Mower
Y650TC	1	F650TC	6' Center Mower
Y650TR	1	F650TR	6' R.H. Mower
YT750	1	F0711	Hitch Assembly
	2	F6613	15" Wheel & Tire
	1	F0707	Crate of Parts
Y750TL	1	F750TL	7' L.H. Mower
Y750TC	1	F750TC	7' Center Mower
Y750TR	1	F750TR	7' R.H. Mower

Chain Kit Option Bundle Numbers

Y410	1 1	F0041 F0040	4' Plate & Rod Chain Kit Crate of Parts
Y510	1 1	F6670 F6673	5' Plate & Rod Chain Kit Carton of Parts
Y610	1 1	F6671 F6674	6' Plate & Rod Chain Kit Carton of Parts
Y710	1 1	F6672 F6675	7' Plate & Rod Chain Kit Carton of Parts

OPTIONS:

F0022	2 5/16" Ball Hitch Assembly
F0028	Triplex Light Kit
F9117	Hyd. Lift Kit

FINISHING MOWER PTO SHAFTS

MAINTENANCE: The cross journals and the shield bearings at both ends of the shaft should be greased every 8 hours. Use 1 or 2 pumps of high temperature grease. The cones on the outer PTO shield must be turned until the access holes line up with the grease nipple in the cross journals. The grease nipple for the shield bearings is on the bottom edge of the cone. The PTO shaft must be pulled apart to grease the cardan tubes. Put about 4 pumps of grease into the female or larger outer tube. Slide the two halves back together. The quick release collars on the ends of the PTO shaft should also be kept lubricated. The cardan tubes and the release collars should be greased about every 20 hours. Clean all grease fittings before injecting grease and immediately replace any damaged or missing grease fittings.

SERVICE: The two major service areas on the mower PTO shafts are the shielding and the cross journals. The outer guards are held on by a nylon shield bearing. The three round white tabs at the bottom edge of the shield cones must all be pushed in to pull the shield off the cardan yoke and tube assembly. To replace the outer guards, first fit the nylon shield bearing into the groove machined into the yoke. Slide on the outer guard till it snaps in. The tabs on the shield bearing must line up with grooves on the inside of the outer guard.

The cross journals must be removed using a press or a vise. Do not use a hammer. Cross journal replacement is done with the outer shield removed. Remove the snap rings at the ends of the cross journal before pressing out. The cups on the ends of the cross journal contain numerous needle bearings. If even one of these needle bearings falls over, you will not be able to assemble the cross journal. Check that the end yoke turns freely after replacing a cross journal. Adjust the spread on the end yoke if necessary to loosen up the turning.

The quick release collars on the ends of the PTO shaft are held on by a snap ring. A pin and spring are inside the collar. Repair immediately if the collar fails to hold the PTO shaft solidly in place.

PTO SHAFT

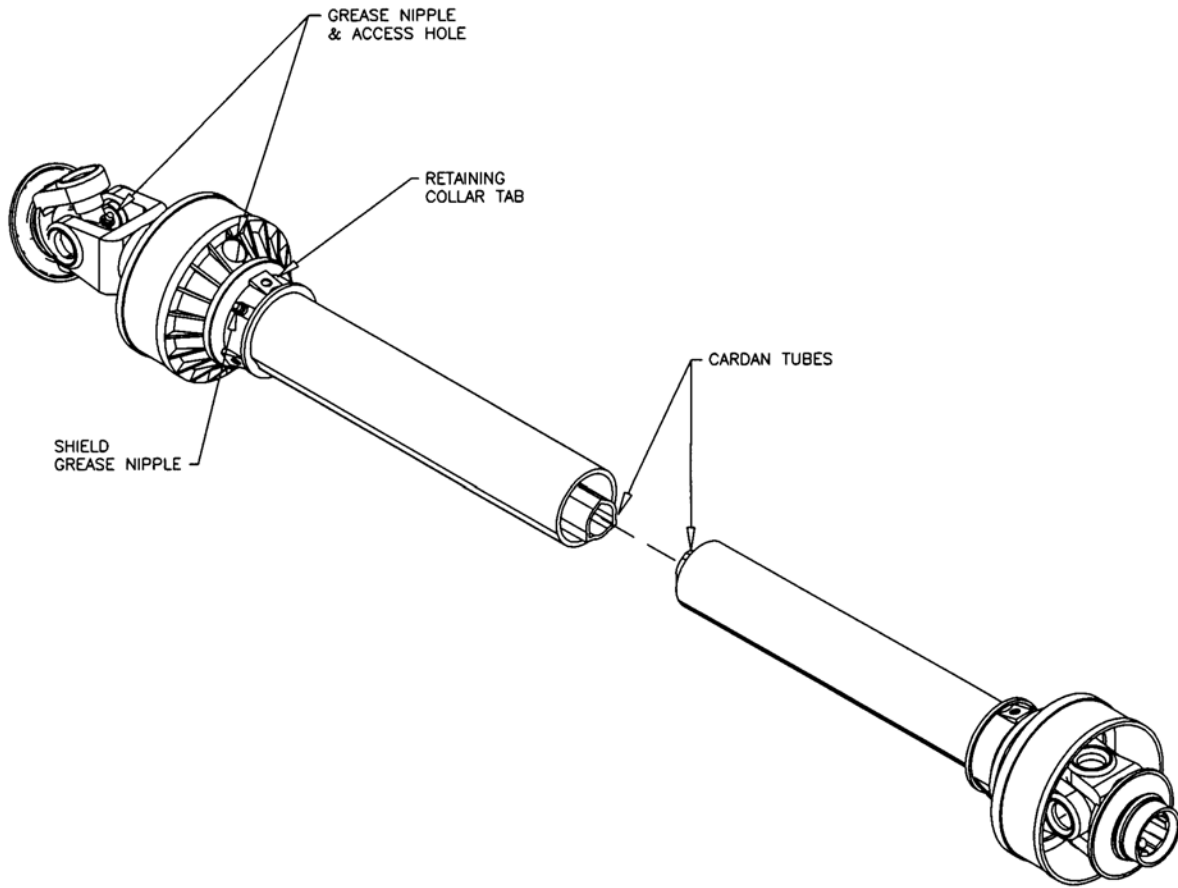

FM-39

MAIN CV PTO SHAFT

MAINTENANCE: The cross journals and the shield bearings at both ends of the shaft should be greased every 8 hours. Use 1 or 2 pumps of high temperature grease. The cones on the outer PTO shield must be turned until the access holes line up with the grease nipple in the cross journals. The grease nipple on the outer cross journal on the CV end is accessible from the outside. There is a separate guard covering the center CV housing. Turn this guard until the access hole lines up with the grease nipple, and grease with 1 or 2 pumps every 8 hours. This grease nipple is particularly important. Failure to keep grease in the CV housing will result in damage to some very expensive PTO parts. The grease nipple for the shield bearings is on the bottom edge of the cone.

The PTO shaft must be pulled apart to grease the cardan tubes. Put about 4 pumps of grease into the female or larger outer tube. Slide the two halves back together. The quick release collars on the ends of the PTO shaft should also be kept lubricated. The cardan tubes and the release collars should be greased about every 20 hours. Clean all grease fittings before injecting grease and immediately replace any damaged or missing grease fittings.

SERVICE: The outer guards are held on by a nylon shield bearing. The three round white tabs at the bottom edge of the shield cones must all be pushed in to pull the shield off the cardan yoke and tube assembly. To replace the outer guards, first fit the nylon shield bearing into the groove machined into the yoke. Slide on the outer guard till it snaps in. The tabs on the shield bearing must line up with grooves on the inside of the outer guard.

The CV joint is covered by a separate guard consisting of two halves joined by six screws. Remove the six screws to pull off the CV cover.

The cross journals must be removed using a press or a vise. Do not use a hammer. Cross journal replacement is done with the outer shields removed. Remove the snap rings at the ends of the cross journal before pressing out. The cups on the ends of the cross journal contain numerous needle bearings. If even one of these needle bearings falls over, you will not be able to assemble the cross journal. Check that the end yoke turns freely after replacing a cross journal. Adjust the spread on the end yoke if necessary to loosen up the turning.

Cross journal replacement on the CV end of the PTO shaft is considerably more difficult than the other end. If replacing both cross journals, it is best to do the outer cross journal first. You must remove the cross journal ends from the CV center housing before removing them from the end yoke. You cannot remove the cross journal if it is not done in this order. If you are only replacing the inner cross journal on the CV end, you must still start by removing the cross journal ends from the CV center housing. The quick release collars on the ends of the PTO shaft are held on by a snap ring. A pin and spring are inside the collar. Repair immediately if the collar fails to hold the PTO shaft solidly in place.

CV PTO SHAFT

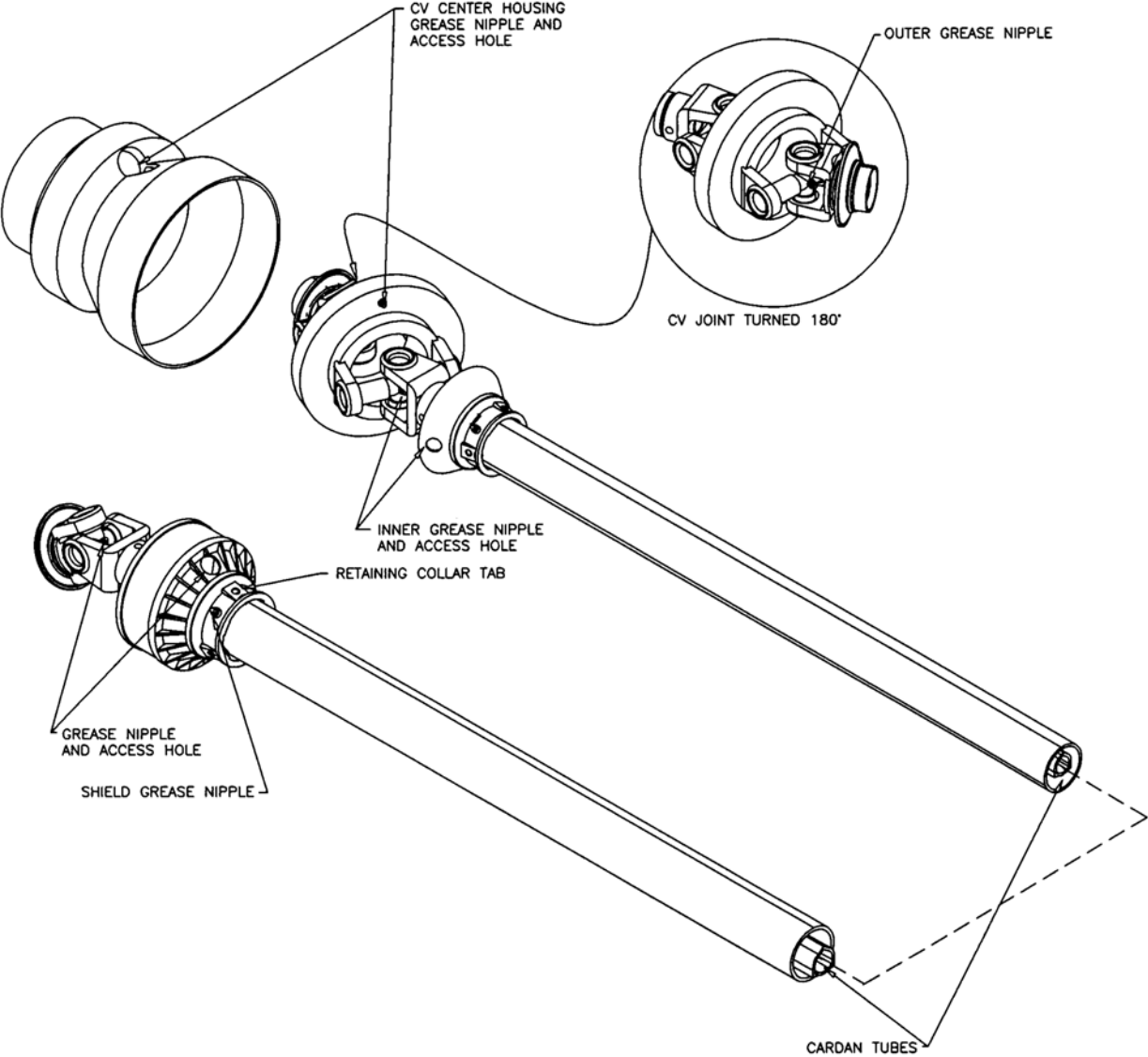

MOWER DECK WHEEL BEARINGS

The mower wheel bearings are packed in grease when they are shipped. They should be repacked in fresh grease once a year or every 200 hours of usage.

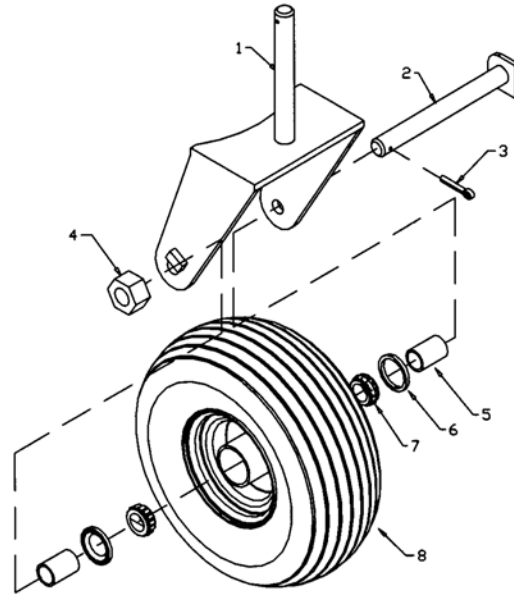

FM-33

MOWER DECK WHEEL BEARINGS

ITEM	PART#	DESCRIPTION
1	902422	Wheel Yoke
2	902489	1" x 9 1/4" long Wheel Yoke Pin
3	812681	3/16" x 1 1/2" Cotter Pin (pl)
4	967498	1" Slotted Hex Nut (NF) 14 (pl)
5	902505	1 3/4" x 1 1/4" O.D. Wheel Spacer (pl)
6	967497	Oil Seal Se 10
7	966776	Bearing Cone (L44643)
8	966195	Tire & Rim (15 x 6 - 6)

TRIPLEX WHEEL BEARINGS

The Triplex Wheel Bearings are packed in grease when they are shipped. They should be repacked in fresh grease once a year or every 200 hours of usage.

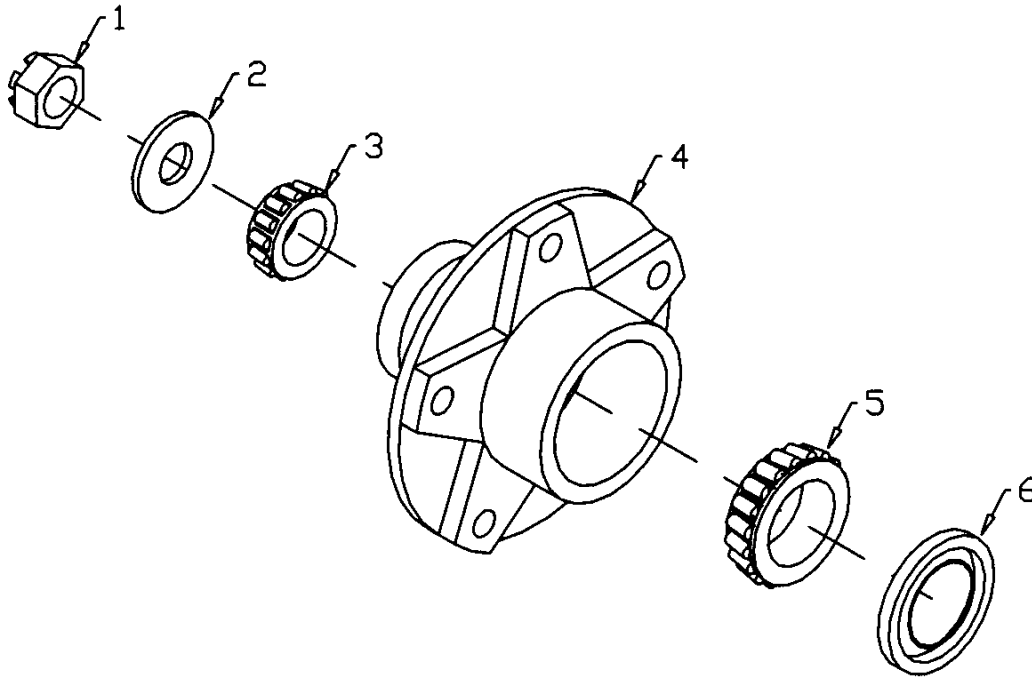

FM-34

TRIPLEX WHEEL BEARINGS

ITEM	PART#	DESCRIPTION
1	81834	3/4" Slotted Hex Nut
2	84050	3/4" S.A.E. Flat Washer (pl)
3	968406	Outer Cone (LM11949)
4	968403	Hub with Bearing Cups (H516)
5	967208	Inner Cone (LM48548)
6	968430	Oil Seal (SE 14X)

BLADE HEIGHT ADJUSTMENT

The mowers must be raised off the ground far enough to pull the wheel yoke (#5) out of the welded sleeves at the ends of the axles (#1). Be sure the tractor is turned off. Pull out the clip (#4) and remove the wheel yoke. There are 1/2" and 1" spacers to adjust the cutting height. The cutting height is 1 3/4" with no spacers under the sleeve at the end of the axles. This can be adjusted using the spacers by 1/2" increments up to 4 3/4". Check to see that the spacers are set at the same height on all the wheel yokes on all the mowers on the triplex.

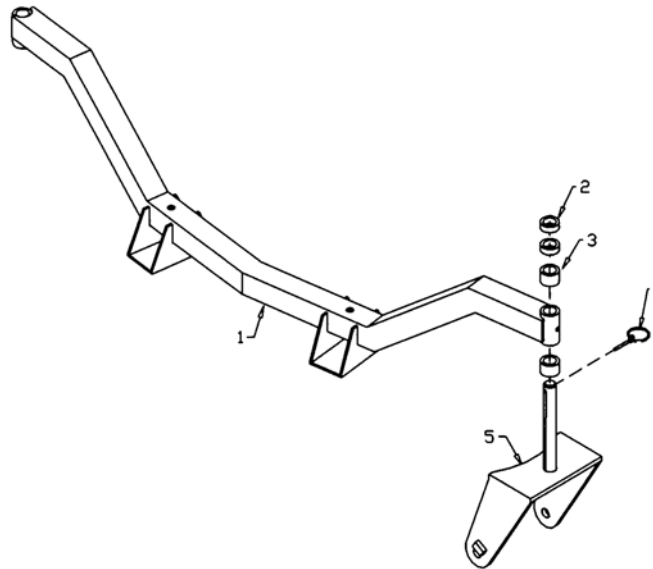

FM-35

BLADE HEIGHT ADJUSTMENT

ITEM	PART#	DESCRIPTION
1	903834	57 1/2" Axle Beam Weldment (4')
	902425	62 1/2" Axle Beam Weldment (5')
	902427	67 1/2" Axle Beam Weldment (6')
	902431	67 1/2" Right Axle Beam Weldment (6')
	902430	67 1/2" Left Axle Beam Weldment (6')
	902433	69 1/2" Right Axle Beam Weldment (7')
	2	902504
3	902503	1" Long x 1 5/8" OD Bushing (pl)
4	966729	3/16" Linch Pin (pl)
5	902422	Wheel Yoke

TRIPLEX SPLITTER GEARBOX AND MOWER GEARBOX LUBRICATION

The gearboxes should be filled with SAE90 oil to the bottom of the level plug when shipped. Check the splitter gearbox and all the mower gearboxes before using and at regular intervals (approximately every 40 hours). See that the oil level is maintained. On the mower gearboxes the vent plug also acts as the fill plug.

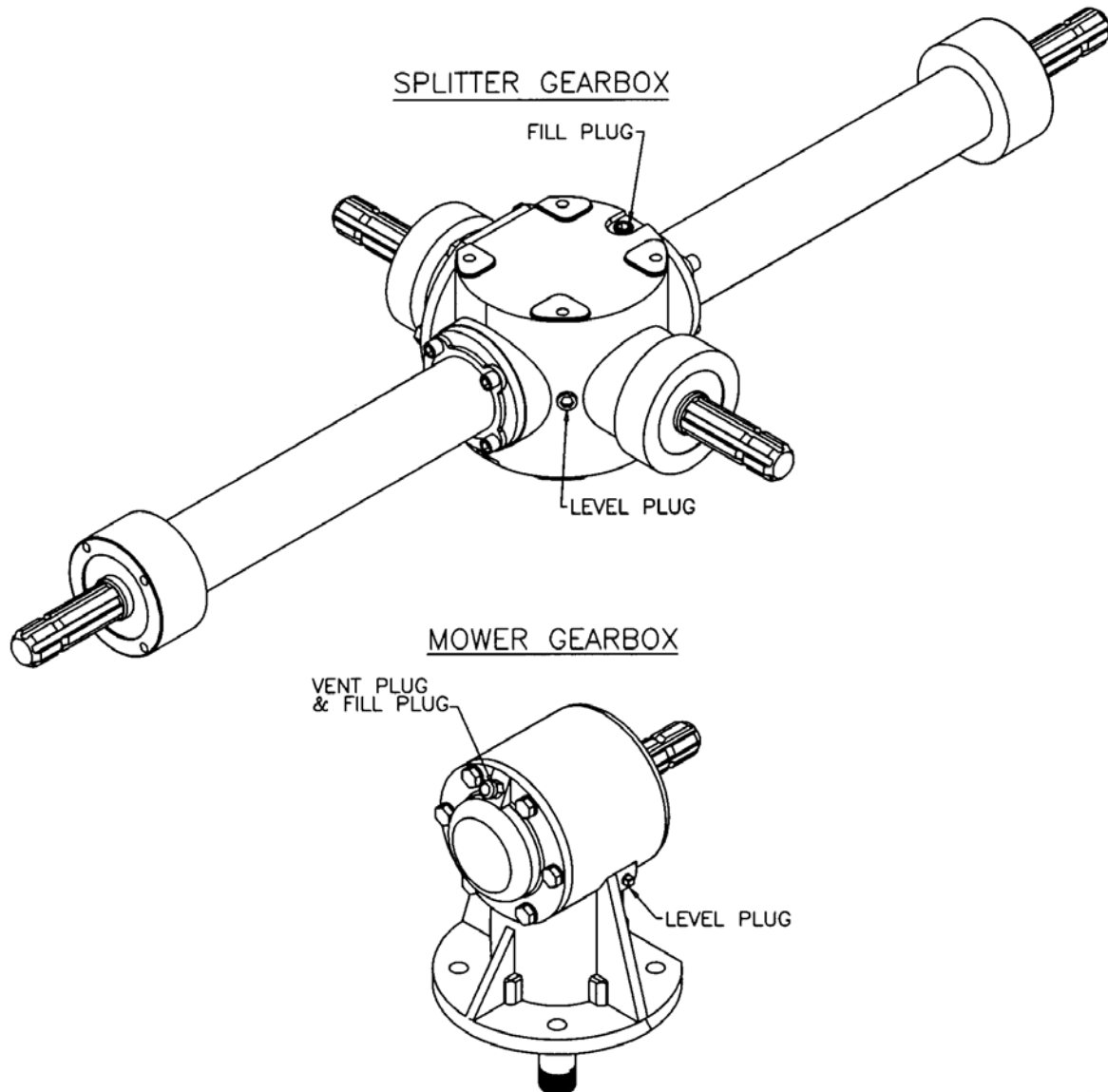

FM-32

BRASS BUSHING REPLACEMENT AND LUBRICATION ON WINGS

The deck mounts (#1) have bushings pressed into the welded sleeve in square tubes. If these bushings need replacement due to wear, the deck mount must be completely removed from the mowers and the triplex frame. These bushings must be removed and replaced on a press. There are two lengths of bushings (#6 & #7) used in each welded sleeve. The longer of the two bushings is on the outside. There is a grease nipple inside a drilled hole in the square tube positioned between the two brass bushings. Give each grease nipple 1 or 2 pumps of a high temperature grease about every 8 hours.

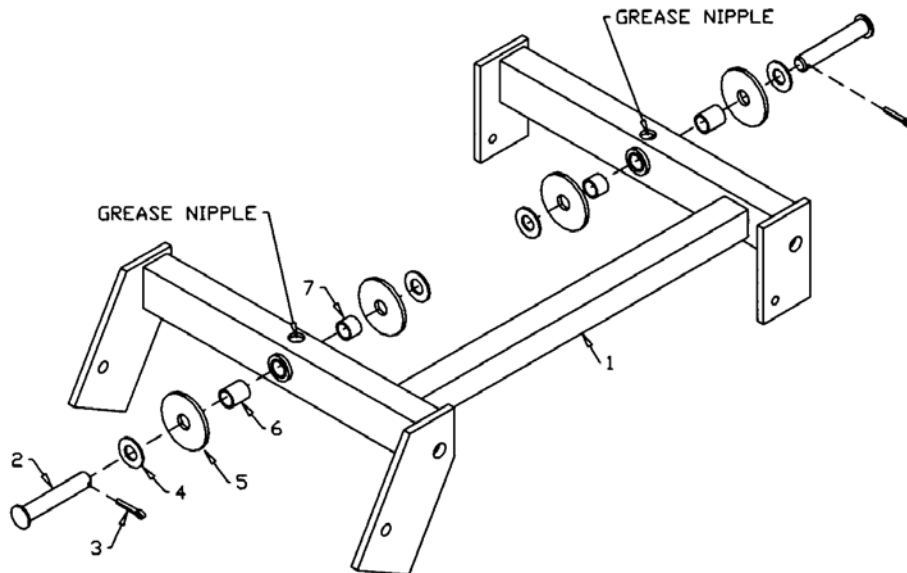

FM-40

BRASS BUSHING REPLACEMENT ON WINGS

ITEM	PART#	DESCRIPTION
1	903630	4' Left Hand Deck Mount Weldment
	903631	4' Right Hand Deck Mount Weldment
	900650	5' Left Hand Deck Mount Weldment
	900651	5' Right Hand Deck Mount Weldment
	900652	6' Left Hand Deck Mount Weldment
	900653	6' Right Hand Deck Mount Weldment
	901207	7' Left Hand Deck Mount Weldment
	901208	7' Right Hand Deck Mount Weldment
2	901399	Pin 1" x 5 5/8" Long
3	9812434	1/4" x 1 1/2" Cotter Pin (pl)
4	84522	1" Flat Washer S.A.E. (pl)
5	902411	Wear Washer 3 3/4" x 1/4" Thick
6	113577	Bushing 1" ID x 1 1/4" OD x 1 3/8" Long
7	113780	Bushing 1" ID x 1 1/4" OD x .88" Long

TRIPLEX FRAME WING AND MOWER SPINDLE LUBRICATION

Use a high temperature grease for all applications. The pivot bushings on the side and rear wings of the main triplex frame have a grease nipple positioned as shown in the illustrations. Give these 1 or 2 pumps of grease about every 8 hours. The mower deck wheel spindles have a grease nipple in the sleeve welded to the ends of the axle and in the wheel hub. These locations should receive 3 or 4 pumps of grease about every 8 hours.

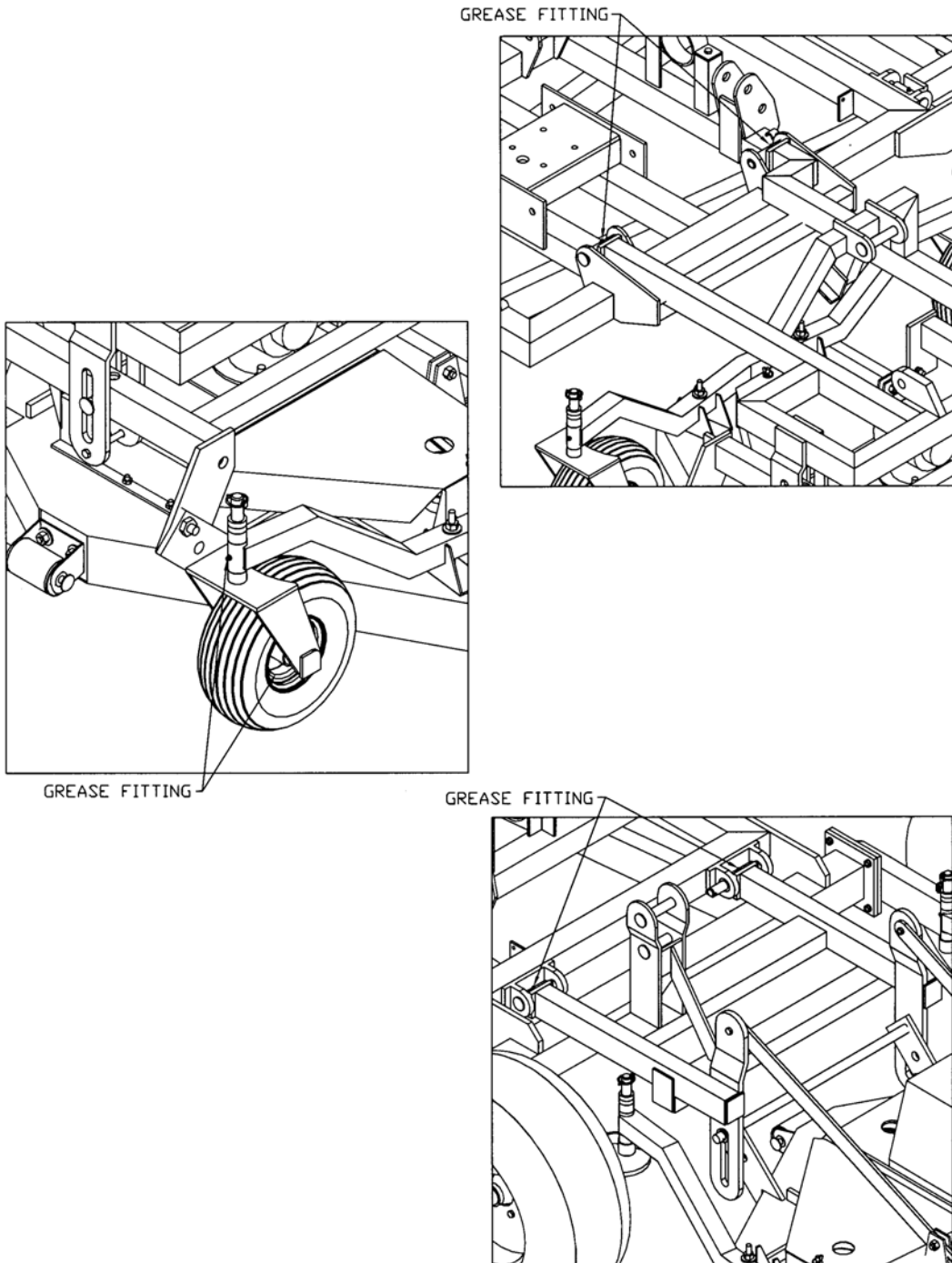

FM-37

SPINDLE REPLACEMENT

OUTER SPINDLES: remove the belt guard on the side required (#7 & #8). Loosen the belts by first loosening the bolts holding the gearbox base plate (#2). Turn the 5/8" hex nut (#3) on the threaded rod on the base plate until there is enough slack in the belt to slip it off the spindle pulley. Remove the snap ring from the spindle shaft and pull off the pulley. Remove the blade from the spindle. The mower will have to be raised off the ground. Take off the four bolts holding on the spindle (#14). After replacing the spindle, be sure that the bolt holding the blade is tightened to 180 ft-lbs. Use a torque wrench. Re-tighten the belts so the center of the belt span will deflect about 1/2" with nominal pressure. Do not forget to tighten the bolts on the gearbox mounting plate.

CENTER SPINDLE: The procedure is the same as for the outer spindles as described above except for the following differences. Both belt guards (#7 & #8) must be removed. After slacking off the belt as described remove the gearbox mounting plate (#6) in one piece with the gearbox and large pulley. Remove the double pulley and replace the spindle. When you replace the belts make sure they are lined up as shown in the drawing. The upper grooves in the double pulleys go around the higher of the single pulleys. The lower grooves of the double pulley line up with the lower single pulley.

Drawing on next page.

TRIPLEX MAINTENANCE – SPINDLE REPLACEMENT

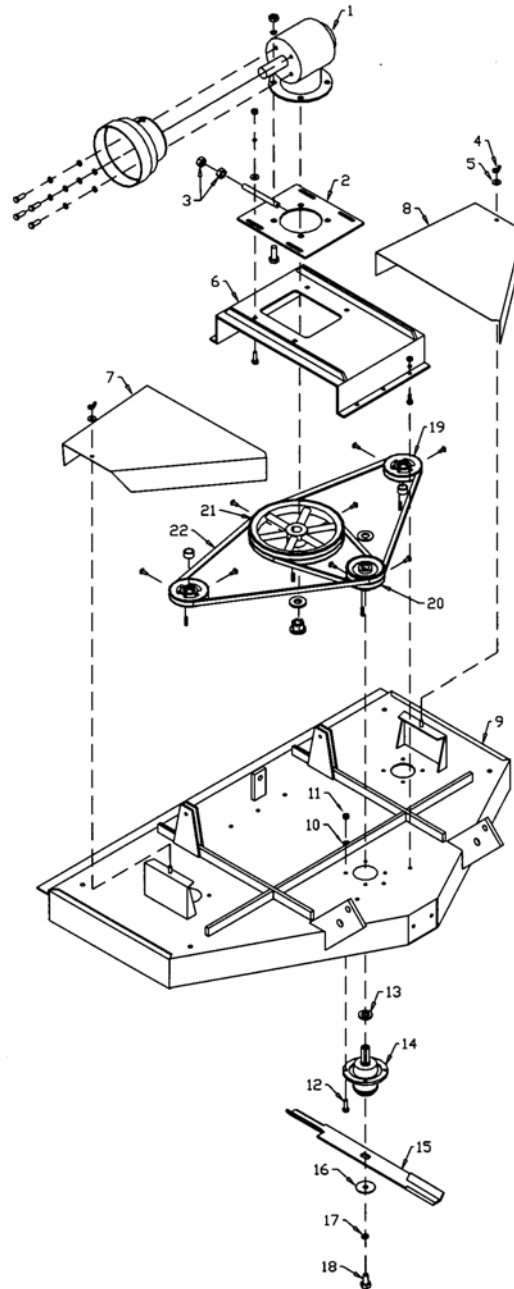

FM-36

SPINDLE REPLACEMENT

ITEM	PART#	DESCRIPTION
1	912300158	Gearbox Assembly
2	980004200	Gearbox Base Plate
3	81676	5/8" Hex Nut (pl)
4	84217	3/8" Wing Nut (pl)
5	84000	3/8" BS Flat Washer (pl)
6	906342	Gearbox Mount Plate (4')
	906343	Gearbox Mount Plate (5'-7')
7	906346	4' Right Hand Belt Guard
	906353	5' Right Hand Belt Guard
	906355	6' Right Hand Belt Guard
	902269	7' Right Hand Belt Guard
8	906347	4' Left Hand Belt Guard
	906354	5' Left Hand Belt Guard
	906356	6' Left Hand Belt Guard
	902268	7' Left Hand Belt Guard
9	903815	4' Rear Discharge Deck
	902667	5' Rear Discharge Deck
	902668	6' Rear Discharge Deck
	902669	7' Rear Discharge Deck
10	81593	3/8" Lock Washer (pl)
11	81592	3/8" Hex Nut (pl)
12	86171	3/8" x 1 1/4" Hex Bolt (pl)
13	912301558	Snap Ring
14	966860	Spindle Assembly complete with Hardware
15	903798	17 3/4" Blade (4')
	966273	21 3/4" Blade (5')
	966274	25 3/4" Blade (6')
	966167	29 3/4" Blade (7')
16	966188	2 1/2"OD x 21/32"ID Washer (pl) (Supplied with Spindle)
17	966190	5/8" Lock Washer Extra Heavy (pl) (Supplied with Spindle)
18	966189	5/8" x 1 1/4" Gr. 8 Hex Bolt Lock (pl) (Supplied with Spindle)
19	904243	3 3/4" Single Sheave (Machined End Up) (4')
	904245	4 1/2" Single Sheave (Machined End Up) (5' & 6')
	904247	5 1/4" Single Sheave (Machined End Up) (7')
20	904244	3 3/4" Double Sheave (4')
	904246	4 1/2" Double Sheave (5' & 6')
	904248	5 1/4" Double Sheave (7')
21	966722	12" Double Sheave (1.25" Bore)
22	904250	B-64 Belts (4')
	904251	B-70 Belts (5')
	973506	B-78 Belts (6')
	973248	B-87 Belts (7')

MOWER DECK BELT ADJUSTMENT

Start by removing both belt guards on the mower deck. Loosen the bolts holding the gearbox base plate (#7). Turn the 5/8" hex nuts (#6) on the threaded rod on the base plate until there is enough slack in the belts to slip them off the spindle pulleys. If the belts can be pulled off by sliding them under the large double pulley, no further disassembly is required. If this is difficult, you can create more space by removing the bolts holding on the gearbox mounting plate (#8) in one piece with the gearbox and large pulley. Lift up the mounting plate assembly slightly and slide the belts underneath. When you replace the belts, make sure they are lined up as shown in the drawing. The upper groove in the double pulleys goes around the higher of the single pulleys. The lower grooves of the double pulleys line up with the lower single pulley. Re-tighten the belts so the center of the belt span will deflect about 1/2" with nominal pressure. Do not forget to tighten the bolts on the gearbox mounting plate.

MOWER DECK BELT ADJUSTMENT

ITEM	PART#	DESCRIPTION
1	912300158	Gearbox Assembly
2	81592	3/8" Hex Nut (pl)
3	81593	3/8" Lock Washer (pl)
4	964001	7/16" ID x 10 Ga Washer (pl)
5	86182	3/8" x 1 1/4" Carriage Bolt (pl)
6	81676	5/8" Hex Nut (pl)
7	980004200	Gearbox Base Plate
8	906342	Gearbox Mount Plate (4')
	906343	Gearbox Mount Plate (5'-7')
9	904243	3 3/4" Single Sheave (Machined End Up) (4')
	904245	4 1/2" Single Sheave (Machined End Up) (5' & 6')
	904247	7" Single Sheave (Machined End Up) (7')
10	904244	3 3/4" Double Sheave (4')
	904246	4 1/2" Double Sheave (5' & 6')
	904248	5 1/4" Double Sheave (7')
11	966722	12" Double Pulley (1.25" Bore)
12	904250	B-61 Belts (4')
	904251	B-70 Belts (5')
	973506	B-78 Belts (6')
	973248	B-87 Belts (7')
13	903815	4' Rear Discharge Deck
	902667	5' Rear Discharge Deck
	902668	6' Rear Discharge Deck
	902669	7' Rear Discharge Deck

MOWER DECK BELT ADJUSTMENT

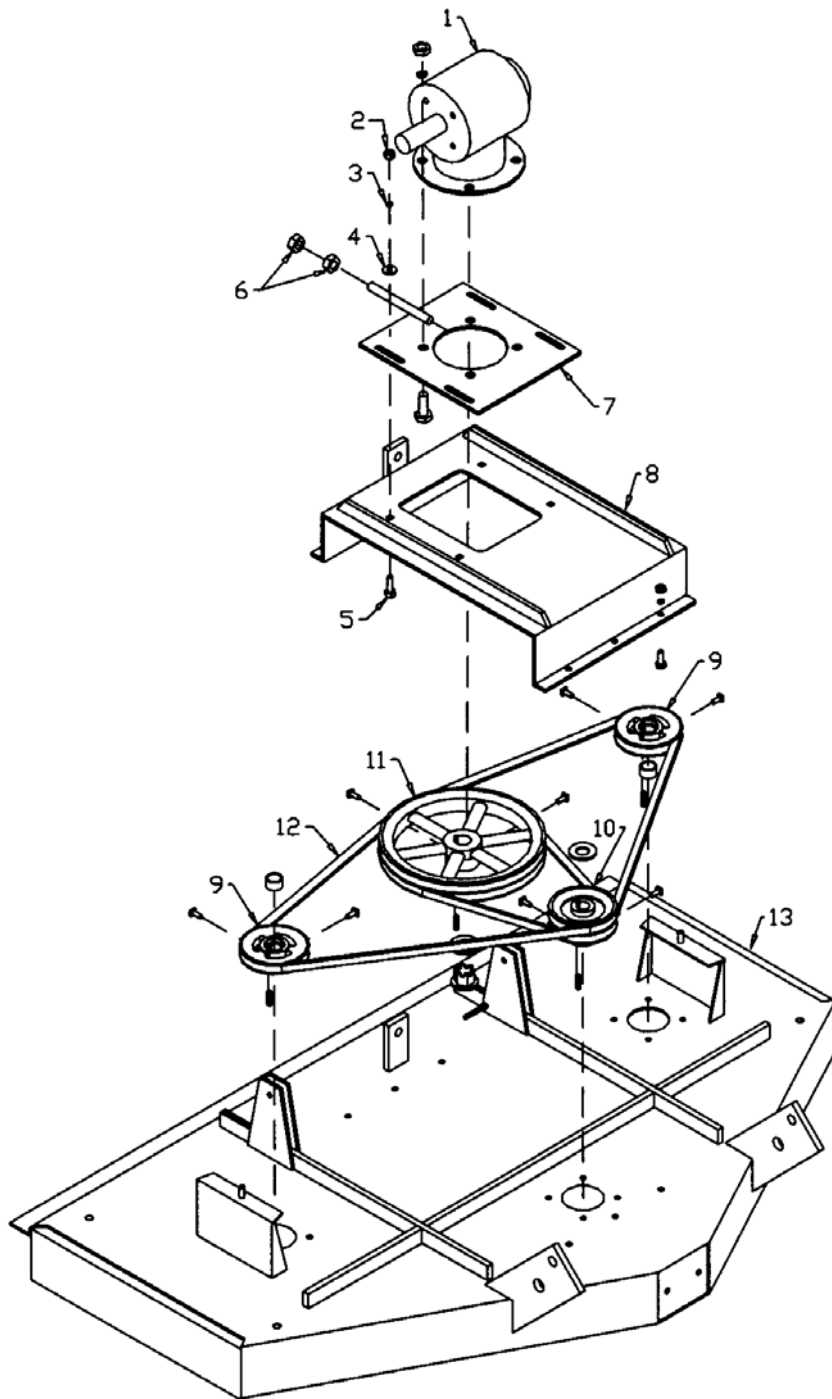

FM-38

UHMW BUSHING REPLACEMENT

A wear resistant UHMW washer is used at the wear points on the side wing deck mounts (#1) at top of page and on the rear wing (#6) at bottom of page. Completely lower the triplex mowers to the ground to take the pressure off of the pins holding the wear washers. On the deck mounts, the washers are on both sides of the square tube where the bushing goes through the tube. The slotted arms welded to the side wings fit on the outside of these washers. On the rear wing, the washer fits between the slotted arm on the rear wing and the welded bracket on the mower deck. Pull the long pin (#7) back far enough to change the wear washers.

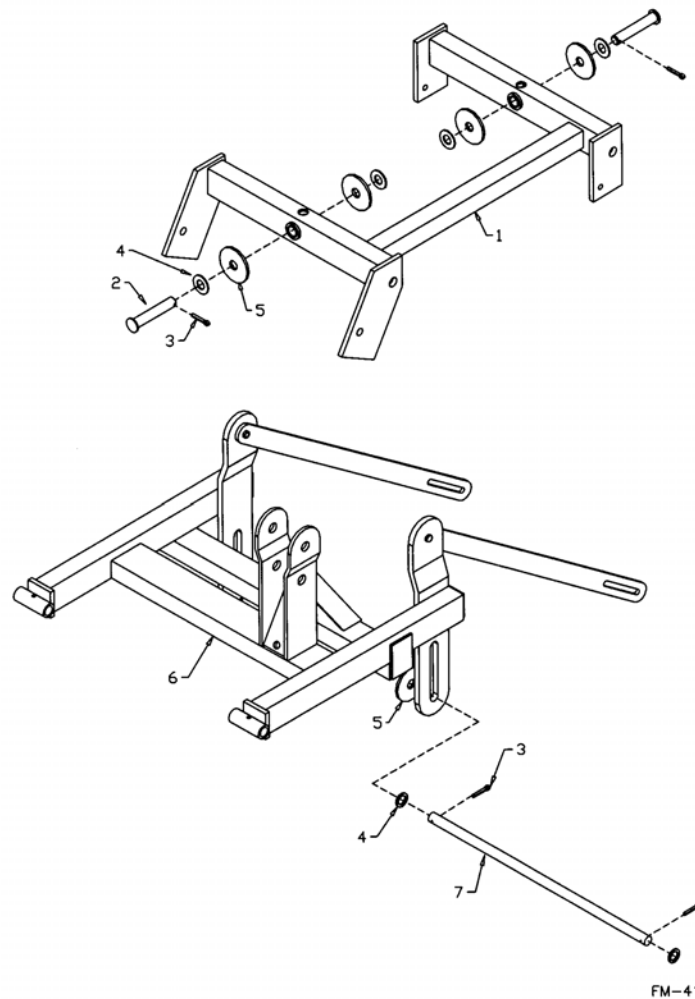

UHMW BUSHING REPLACEMENT

ITEM	PART#	DESCRIPTION
1	903630	4' Left Hand Deck Mount Weldment
	903631	4' Right Hand Deck Mount Weldment
	900650	5' Left Hand Deck Mount Weldment
	900651	5' Right Hand Deck Mount Weldment
	900652	6' Left Hand Deck Mount Weldment
	900653	6' Right Hand Deck Mount Weldment
	901207	7' Left Hand Deck Mount Weldment
	901208	7' Right Hand Deck Mount Weldment
2	901399	Pin 1" x 5 5/8" Long
3	9812434	1/4" x 1 1/2" Cotter Pin (pl)
4	84522	1" Flat Washer S.A.E. (pl)
5	902411	Wear Washer 3 3/4" x 1/4" Thick
6	903614	Rear Wing Weldment (4')
	901168	Rear Wing Weldment (5'-7')
7	900703	Rear Wing Bar 1" x 29 3/8"

BLADE REPLACEMENT

The mower deck must be securely blocked up or locked in place before doing a blade replacement. When replacing or grinding blades, all three blades must be replaced or reground at the same time to maintain the proper balance in the cutting unit. Use heavy leather gloves to handle the blades. It is easiest to remove the centre bolt if you anchor the blade solidly. There are devices sold at hardware stores for this purpose. Be sure to tighten the centre bolt and lock washer securely when replacing blades. Use a torque wrench to re-tighten spindle bolts to 180 ft.-lbs. The bolts have a patch of thread lock material pre-applied which will hold for up to five usages. If replacing the lock washer, use an extra heavy duty as supplied with the spindle.

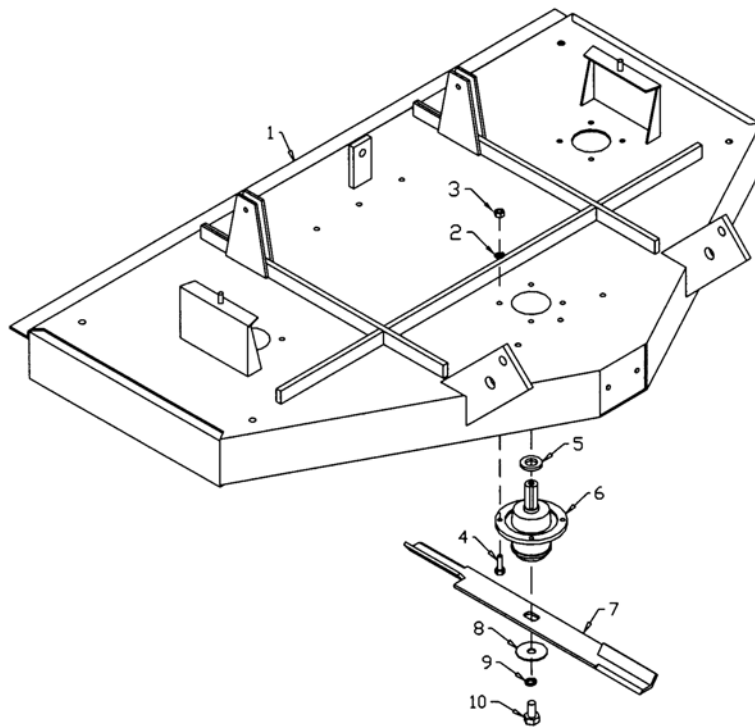

FM-42

BLADE REPLACEMENT

ITEM	PART#	DESCRIPTION
1	903815	4' Rear Discharge Deck
	902667	5' Rear Discharge Deck
	902668	6' Rear Discharge Deck
	902669	7' Rear Discharge Deck
2	81593	3/8" Lock Washer (pl)
3	81592	3/8" Hex Nut (pl)
4	86171	3/8" x 1 1/4" Hex Bolt (pl)
5	912301558	Snap Ring
6	906339	Spindle Assembly (4',5' & 6') (complete with Hardware)
	966860	Spindle Assembly (7') (complete with Hardware)
7	903798	17 3/4" Blade (4')
	966273	21 3/4" Blade (5')
	966274	25 3/4" Blade (6')
	966167	29 3/4" Blade (7')
8	966188	2 1/2"OD x 21/32"ID Washer (pl) (Supplied with Spindle)
9	966190	5/8" Lock Washer Extra Heavy (pl) (Supplied with Spindle)
10	966189	5/8" x 1" Gr. 8 Hex Bolt Lock (pl) (Supplied with Spindle)

SERVICE NOTES

A basic requirement for a steady top performance of the machine is proper and regular maintenance.

Use only original BUHLER parts.

Keep the machine in a functioning and efficient condition by completing the maintenance and lubrication work as listed in the maintenance checklist. If maintenance is due, no work is to be done with the machine. Discovered defects have to be carefully remedied at once.

ATTENTION! The maintenance of the machine should be done by trained personnel. Naturally, the machine has to be secured prior to beginning any maintenance work.

Intervals of Maintenance: The intervals are based on average working conditions and strain. The various intervals of maintenance depend on the time elapsed or service hours complete, which ever is reached first. The intervals given here are based on the quality of material specified in this manual.

EVERY 8 HOURS OF USE**DATE**

grease PTO cross journals and shield bearings	_____
grease CV PTO cross journals and shield bearings	_____
grease CV PTO housing	_____
grease brass bushings on mower deck	_____
grease pivot bushings for side and rear wings	_____
grease mower deck wheel spindles	_____
grease mower spindles	_____

EVERY 20 HOURS OF USE

grease PTO cardan tubes and release collars	_____
grease CV PTO cardan tubes and release collars	_____

EVERY 40 HOURS OF USE

check oil level of gearboxes	_____
------------------------------	-------

YEARLY OR EVERY 200 HOURS OF USE

repack mower wheel bearings	_____
repack triplex wheel bearings	_____

DIVISION LOCATIONS

Farm King Division
301 Mountain Street S.
Morden, MB R6M 1X7
Ph.: (204) 822-4467
Fax: (204) 822-6348

Allied Division
1201 Regent Ave. W.
Box 1003
Winnipeg, MB R2C 3B2
Ph.: (204) 661-8711
Fax: (204) 654-2503

Inland Division
675 Washington Ave.
Winnipeg, MB R2K 1M4
Ph: (204) 667-7854
Fax: (204) 669-2599

B.I.I. Division
1330 43rd Street N.W.
Fargo, ND 58102
Ph: (701) 282-7014
Fax: (701) 282-5865

CANADIAN WAREHOUSES

B.C., Abbotsford
(604) 864-2665

AB, Edmonton
(403) 962-6991

SK, Regina
(306) 781-2300

ON, Woodstock
(519) 539-0435

ON, Jasper
(613) 283-1758

QC, Dorion
(450) 455-4840

U.S. WAREHOUSES

AR, West Memphis
(870) 732-3132

GA, Stone Mountain
(770) 908-9439

IA, Lakeview
(712) 657-8585

ID, Meridian
(208) 887-6006

IN, Clarksville
(812) 284-3376

KS, Wichita
(316) 265-9577

MN, Lakeville
(952) 469-5267

MT, Billings
(406) 248-7771

ND, Bismarck
(701) 223-1886

ND, Fargo
(701) 282-7003

NY, Syracuse
(315) 463-5276

OH, Youngstown
(330) 793-0862

OR, Portland
(503) 234-0378

SD, Huron
(605) 352-8616

TX, Houston
(713) 928-2632

UT, Salt Lake City
(801) 972-4321

WI, Portage
(608) 742-1370

OFFSHORE WAREHOUSES

Burando Hill
Katanning
W. Australia
011-618-98-214422

Chihuahua, Mexico
011-52-158-90306

John Kerr Equipment Ltd.
Wilcoxholm Farm
Linlithgow, W. Lothian
Scotland
011-441-506-842280

Skovde, Sweden
011-46-500-452651

Naestved, Denmark
011-45-557-29511

bühler

Buhler Manufacturing "a partnership"

301 Mountain Street S.
Morden MB.
R6M 1X7
Ph.: (204) 822-4467
Fax: (204) 822-6348
www.buhler.com