

TECHNICAL DATASHEET

Desiccant dehumidifier MDC8000



Vast experience

Practical experience in the desiccant dehumidification more than 10 years



Made in Europe

All components made exclusively by European manufacturers



EU standards

The equipments complies to all of the applicable EU directives and regulations

GENERAL INFORMATION

Desiccant dehumidifier MDC8000 designed for general purposes – room air dehumidification and process drying. The compact construction allows extended periods of operation with a minimum of maintenance. Especially suitable for low temperature and low humidity operation. Unit includes desiccant rotor, EC-fans, reactivation heater, pocket filters and controls. Panels insulated with 40mm rock wool insulation.

In addition to above mentioned application, desiccant dehumidifiers are irreplaceable in:

- protecting against window condensation and glass ceiling in the administrative as well as residential buildings;
- improving the quality of the finishing works during apartment repairs due to drying without thermal movements in the covering products used for walls, floor and ceiling;
- elimination of the effects of the floods, drying new buildings;
- increasing the shelf life of hygroscopic materials: medicines, detergents, building materials and other bulk materials;
- maintaining a low level of humidity during the production of food items as well as products made of wood, rubber and plastic, during the manufacture of furs;
- maintaining the marketable condition of clothing and packaging items;
- reducing the growth of bacteria, etc.

METHOD OF OPERATION

A desiccant dehumidifier removes water from a flow of the air that passes through it. The heart of this process is an adsorption rotor coated with a special substance that absorbs the water molecules that make up the moisture in the passing air (Process air). When saturated, the rotor is rotated over to a regeneration zone, where it is dried with heated air (Reactivation air). The warm, humid regeneration air is led away out of the unit (Wet air) and the rotor is once again ready to absorb water molecules.

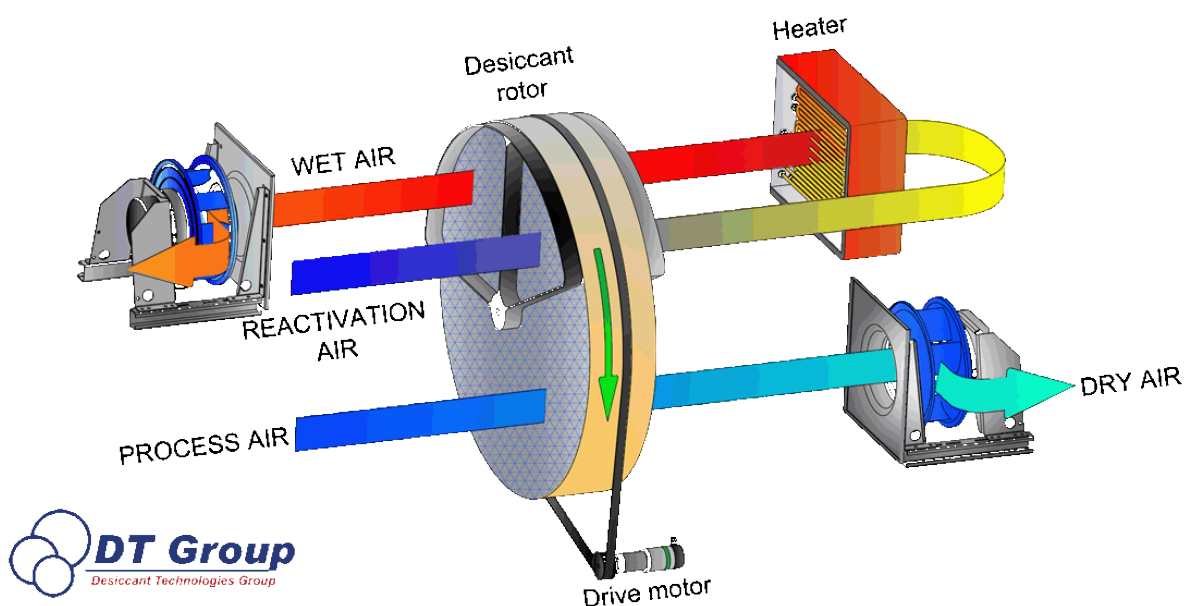

CONSTRUCTIONAL FEATURES

- The casing is completely hermetic and panels are made of 1,0mm AluZinc sheet metal with isolation of 40mm (rock wool); it has high resistance to atmospheric corrosion. Powder painted panels (outside only); rigid frame made of 1,5mm AluZinc sheet metal (powder painted completely) to achieve rigidity
- Compact design and low weight of the unit
- High performance at low temperatures and low relative humidity in a room
- Optional humidistat is available as an accessory
- Microprocessor based control (optional)
- Tubular electric heating elements for regeneration (standard unit) as well as on request with water, steam or gas heating coil (customized unit)
- Easy access to the internal components of the dehumidifier for the maintenance
- EC-fans
- Pocket filters G4 to F9 on request
- High efficiency of the washable silica gel rotor
- All components made exclusively by European manufacturers

TECHNICAL DATA

Process air

Rated airflow8000 m³/h
 Available static pressure.....280 Pa

Reactivation air

Rated airflow2500 m³/h
 Available static pressure.....150 Pa

Power supply (electric reactivation)

(3x400V, 50 Hz).....83 kW
 Current120 A

Power supply (steam/water/gas reactivation)

(3x400V, 50 Hz).....11 kW
 Current16 A

Miscellaneous data

Dehumidification capacity
 (at 20 °C, 60%RH)54,0 kg/h
 Weight1000 kg
 Operating temperature-30/+40°C
 Max noise level
 without ductworks.....73 dBA
 Air filter (pocket)EU4+EU9
 IEC protective classIP55
 Insulation.....40 mm

DEHUMIDIFICATION CAPACITY

Approximate capacity in kg/h at different inlet process air relative humidity (%) and temperature (°C)

	50%	60%	70%	80%	90%
5°C	24,5	28,1	33,0	37,0	40,0
10°C	32,0	37,3	42,1	46,2	51,0
20°C	48,2	54,0	59,0	62,7	66,1
30°C	57,3	62,0	66,1	69,8	71,6

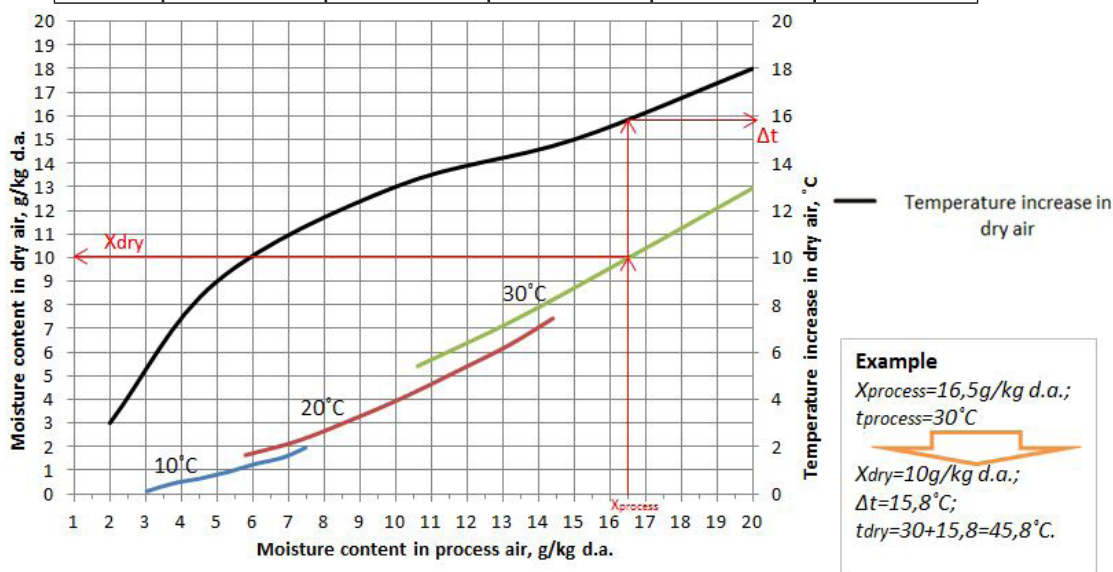

DIMENSIONS

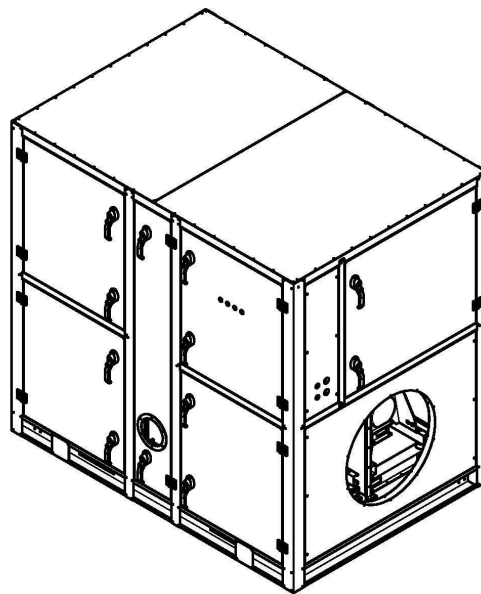
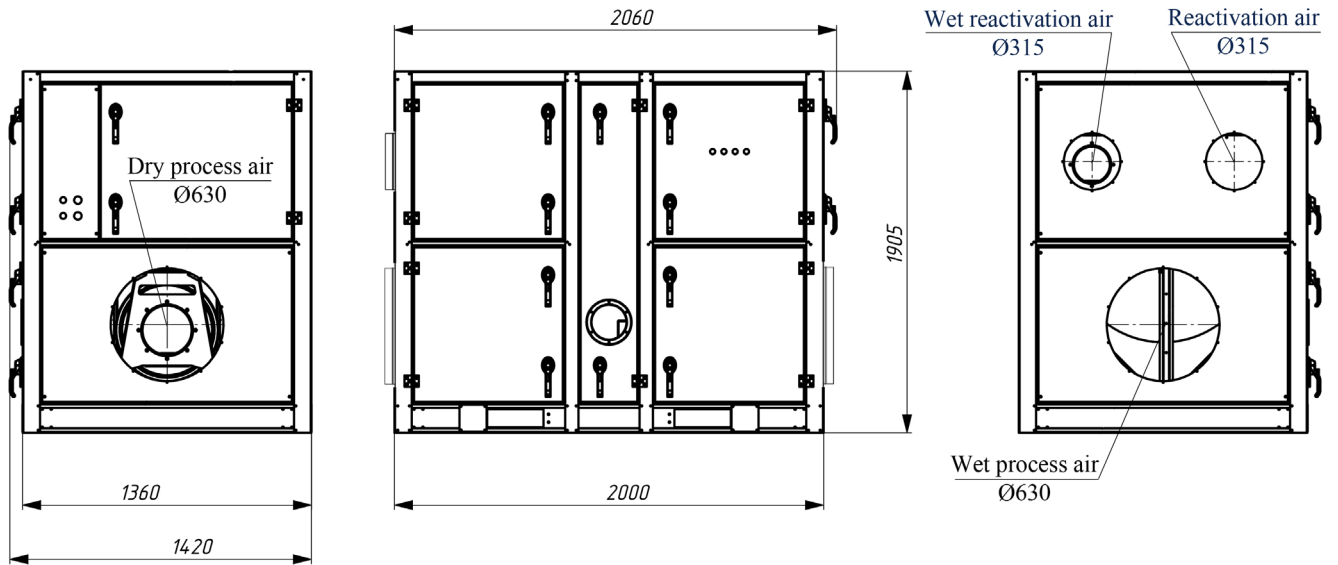

Changes are possible without notice