

Burner assembly

T-D2-IN/OS

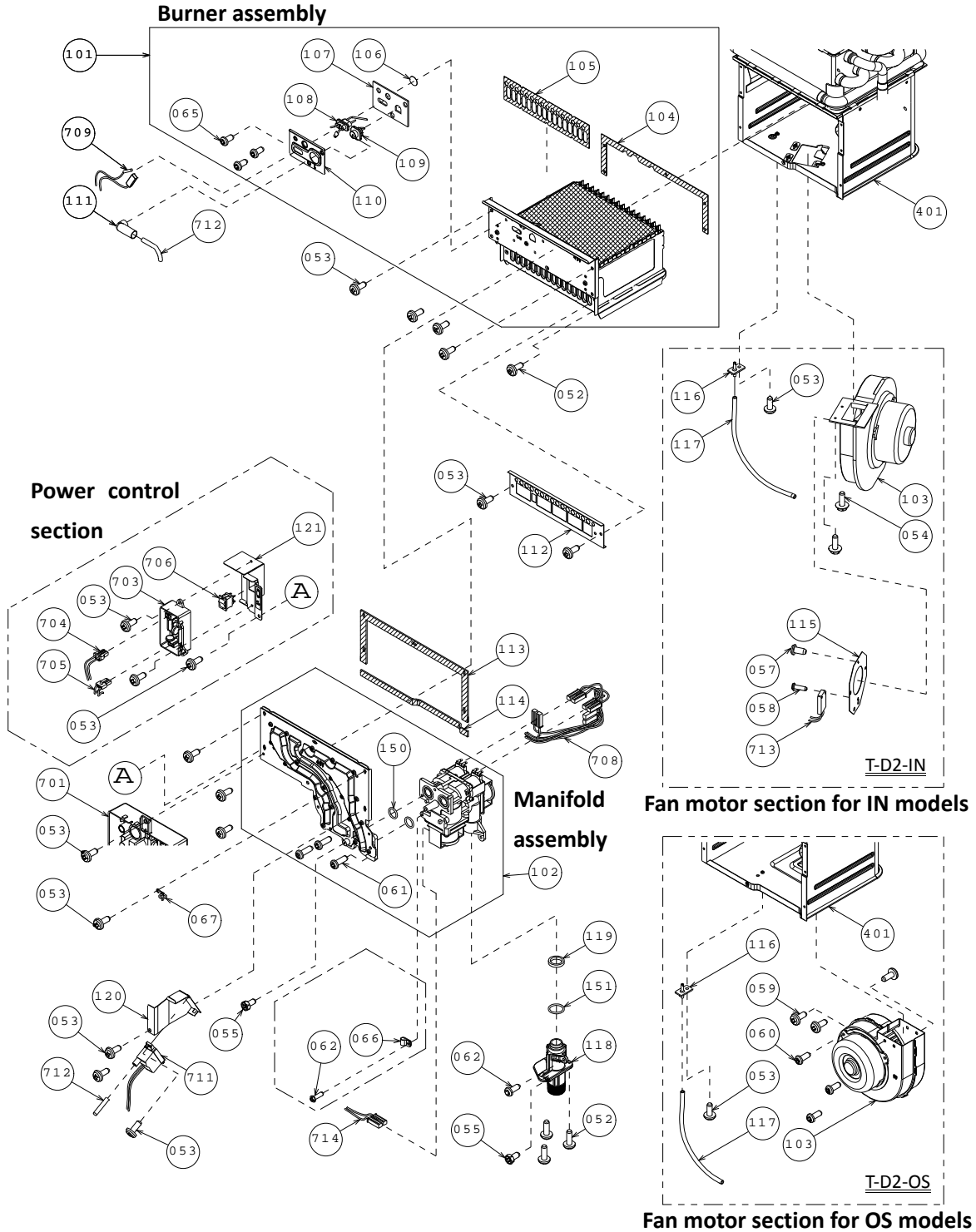

Computer board assembly

T-D2-IN/OS

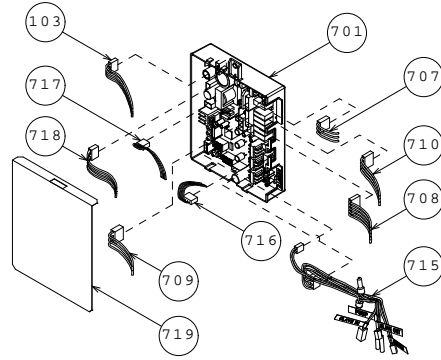

Water way assembly

T-D2-IN/OS

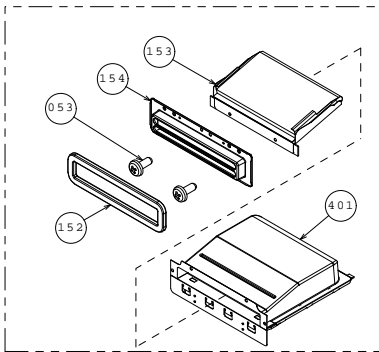
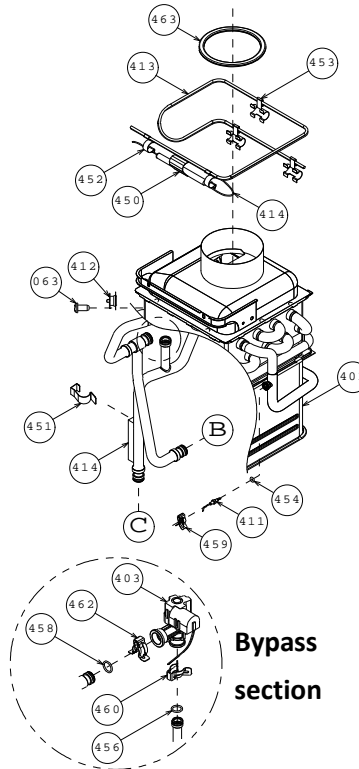

Exhaust section (OS model)

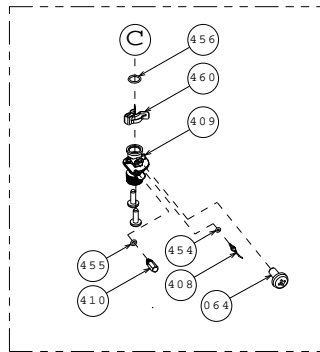

Water outlet section

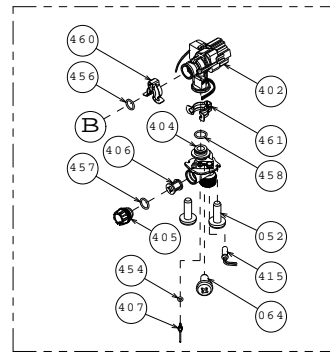

Water inlet section

14. Parts list

Item #	Part #	Description	Common parts for other models
001	EK402	Case assembly (IN)	T-K4-IN
	EKK41	Case assembly (OS)	T-K3-OS, T-K4-OS
002	EK434	Front cover (IN)	
	EK435	Front cover (OS)	
003	EK401	Air blockage plate	T-KJr2-IN/OS, T-K4-IN/OS
004	EKJ09	Bracket	T-K3, T-K3-Pro, T-K3-SP/OS, T-KJr2-IN/OS, T-K4-IN/OS
005	EKJ64	Junction box	T-K3, T-K3-Pro, T-K3-SP/OS, T-H2-DV/OS , T-KJr2-IN/OS, T-K4-IN/OS, T-M50, T-M32
006	EKJ66	Junction box inner plate	T-K3, T-K3-Pro, T-K3-SP/OS, T-H2-DV/OS T-KJr2-IN/OS, T-K4-IN/OS
007	EKK5H	Back guard panel	T-K3, T-K3-Pro, T-K3-SP/OS, T-K4-IN/OS
050	EW000	Screw M4×12 (W/Washer)	*
051	EW001	Screw M4×10 (w/washer)	*
052	EW002	Screw M4×10 (Coated)	*
053	EW003	Screw M4x10	*
054	EW004	Hex head screw M4×12 (W/Washer)	*
055	EW005	Hex head screw M4x8	*
056	EX014	Screw M4x10	*
057	EW00B	Screw M3x6 SUS3	*
058	EW008	Screw M3x10	*
059	EW00H	Pan screw M4x12 (W/Washer)	*
060	EW024	Pan screw M4x10 FEZN	*
061	EKK31	Tap tight screw M4x12 FEZN	*
062	EW006	Pan screw M4x10	*
063	EW00A	Screw M3x6	*
064	EW009	Screw M4x6	*
065	EW00D	Pan screw M4x8	*
066	EC00X	Nylon clamp	T-K3, T-K3-Pro, T-K3-SP/OS, T-H2-DV/OS, T-KJr2-IN/OS, T-K4-IN/OS, T-M32

Item #	Part #	Description	Common parts for other models
067	EM167	Wire clamp 60	T-K3, T-K3-Pro, T-K3-SP/OS, T-H2-DV/OS, T-KJr2-IN/OS, T-K4-IN/OS, T-M50, T-M32
101	EKH5W	Burner assembly	T-H2-DV/OS, T-K4-IN/OS
102	EKH6T	Manifold with gas valve assembly LP	T-H2-DV/OS, T-K4-IN/OS
	EKK5K	Manifold with gas valve assembly NA	T-K4-IN/OS
103	EKK25	Fan motor (IN)	T-K3, T-K3-Pro, T-K3-SP, T-H2-DV/OS, T-K4-IN, T-M50, T-M32
	EKK54	Fan motor (Out)	T-K3-OS, T-K4-OS
104	EKK0G	Burner holder gasket	T-K3, T-K3-Pro, T-K3-SP/OS, T-H2-DV/OS, T-K4-IN/OS, T-M50
105	EKK2X	Burner gasket	T-K3, T-K3-Pro, T-K3-SP/OS, T-H2-DV/OS, T-KJr2-IN/OS, T-K4-IN/OS
106	EKK2V	Burner window	T-K3, T-K3-Pro, T-K3-SP/OS, T-H2-DV/OS, T-KJr2-IN/OS, T-K4-IN/OS, T-M50, T-M32
107	EKK2W	Rod holder gasket	T-H2-DV/OS, T-KJr2-IN/OS, T-K4-IN/OS, T-M50, T-M32
108	EKK0E	Flame rod	T-K3, T-K3-Pro, T-K3-SP/OS, T-H2-DV/OS, T-K4-IN/OS, T-M50, T-M32
109	EKK0F	Igniter rod	T-K3, T-K3-Pro, T-K3-SP/OS, T-H2-DV/OS, T-K4-IN/OS, T-M50, T-M32
110	EKK32	Rod holder	T-K3, T-K3-Pro, T-K3-SP/OS, T-H2-DV/OS, T-K4-IN/OS, T-M50, T-M32
111	EKN61	Rod cap	T-K3, T-K3-Pro, T-K3-SP/OS, T-H2-DV/OS, T-KJr2-IN/OS, T-K4-IN/OS, T-M50, T-M32
112	EK412	Burner damper	T-K4-IN/OS
113	EKK2Y	Manifold gasket A	T-K3, T-K3-Pro, T-K3-SP/OS, T-H2-DV/OS, T-KJr2-IN/OS, T-K4-IN/OS, T-M50
114	EKK2K	Manifold gasket B	T-K3, T-K3-Pro, T-K3-SP/OS, T-H2-DV/OS, T-KJr2-IN/OS, T-K4-IN/OS, T-M50
115	TU001	Fan damper	T-K4-IN
116	EKK2D	Pressure port	T-K3, T-K3-Pro, T-K3-SP, T-H2-DV/OS, T-K4-IN/OS, T-M50, T-M32

Item #	Part #	Description	Common parts for other models
117	EKK2N	Combustion chamber tube (In)	T-K3, T-K3-Pro, T-K3-SP, T-H2-DV/OS, T-K4-IN
	EX019	Combustion chamber tube (Out)	T-K4-OS, T-M50
118	EKK1E	Gas inlet	T-K3, T-K3-Pro, T-K3-SP/OS, T-H2-DV/OS, T-KJr2-IN/OS, T-K4-IN/OS
119	EKK2Z	Gas inlet ring	T-K3, T-K3-Pro, T-K3-SP/OS, T-H2-DV/OS, T-KJr2-IN/OS, T-K4-IN/OS
120	EKK1B	Igniter plate	T-K3, T-K3-Pro, T-K3-SP/OS, T-H2-DV/OS, T-KJr2-IN/OS, T-K4-IN/OS, T-M50, T-M32
121	EK436	Surge box plate	
150	EZP18	O-ring P18 NBR (Black)	T-K3, T-K3-Pro, T-K3-SP/OS, T-KJr2-IN/OS, T-K4-IN/OS, T-M50
151	EK042	O-ring P20 NBR (Black)	T-K3, T-K3-Pro, T-K3-SP/OS, T-H2-DV/OS, T-KJr2-IN/OS, T-K4-IN/OS, T-M50
152	EKK3G	Silicon ring	T-K3-OS, T-K4-OS, T-M50
153	EKK53	Rain protection plate in Exhaust chamber	T-K3-SP/OS, T-KJr2-OS, T-K4-OS
154	EKK56	Exhaust port	T-K3-OS, T-KJr2-IN/OS
401	TU002	Heat exchanger assembly (IN)	
	EK437	Heat exchanger assembly (OS)	
402	EK438	Flow adjustment valve / Flow sensor	
403	EKK0U	Bypass valve	T-K3, T-K3-Pro
404	EKK1U	Water inlet	T-K3, T-K3-Pro, T-K3-SP/OS, T-KJr2-IN/OS, T-K4-IN/OS
405	EKK2B	Inlet drain plug	T-K3, T-K3-Pro, T-K3-SP/OS, T-KJr2-IN/OS, T-K4-IN/OS
406	EKK2C	Inlet water filter	T-K3, T-K3-Pro, T-K3-SP/OS, T-KJr2-IN/OS, T-K4-IN/OS
407	EKK38	Inlet thermistor	T-K3, T-K3-Pro, T-H2-DV/OS, T-M50, T-M32
408	EKK1A	Mixing thermistor	T-K3, T-K3-Pro, T-M50
409	EKK1V	Water outlet	T-K3, T-K3-Pro, T-K3-SP/OS, T-KJr2-IN/OS, T-K4-IN/OS

Item #	Part #	Description	Common parts for other models
410	EKK2E	Outlet drain plug	T-K3, T-K3-Pro, T-K3-SP/OS, T-KJr2-IN/OS, T-K4-IN/OS, T-M50
411	EKK2T	Output thermistor	T-K3, T-K3-Pro, T-H2-DV/OS, T-M50, T-M32
412	EKN34	Hi-Limit switch	T-K3, T-K3-Pro, T-K3-SP/OS, T-H2-DV/OS, T-M50, T-M32
413	EK333	Overheat-cut-off fuse	T-K3, T-K3-Pro, T-K3-SP/OS, T-KJr2-IN/OS, T-K4-IN/OS, T-M50
414	EKK2R	Heater	T-K3, T-K3-Pro, T-K3-SP/OS, T-KJr2-IN/OS, T-K4-IN/OS
415	EKK2P	Inlet heater	T-K3, T-K3-Pro, T-K3-SP/OS, T-H2-DV/OS, T-KJr2-IN/OS, T-K4-IN/OS, T-M32
450	EKK27	Pipe heater fixing plate	T-K3, T-K3-Pro, T-K3-SP/OS, T-H2-DV/OS, T-KJr2-IN/OS, T-K4-IN/OS, T-M50, T-M32
451	EK031	Heater fixing plate 16	T-H2-DV/OS, T-KJr2-IN/OS, T-K4-IN/OS, T-M50, T-M32
452	EKK26	Fuse fixing plate 18	T-K3, T-K3-Pro, T-K3-SP/OS, T-H2-DV/OS, T-KJr2-IN/OS, T-K4-IN/OS, T-M50, T-M32
453	EK029	Fuse fixing plate 14	T-K3, T-K3-Pro, T-K3-SP/OS, T-KJr2-IN/OS, T-K4-IN/OS
454	EZM04	O-ring P4 FKM	T-K3, T-K3-Pro, T-K3-SP/OS, T-H2-DV/OS, T-KJr2-IN/OS, T-K4-IN/OS, T-M50, T-M32
455	EZM06	O-ring P6 FKM	T-K3, T-K3-Pro, T-K3-SP/OS, T-H2-DV/OS, T-KJr2-IN/OS, T-K4-IN/OS, T-M50, T-M32
456	EZM14	O-ring P14 FKM	T-K3, T-K3-Pro, T-K3-SP/OS, T-H2-DV/OS, T-KJr2-IN/OS, T-K4-IN/OS
457	EZM15	O-ring P15 FKM	T-K3, T-K3-Pro, T-K3-SP/OS, T-H2-DV/OS, T-KJr2-IN/OS, T-K4-IN/OS, T-M50, T-M32
458	EZM16	O-ring P16 FKM	T-K3, T-K3-Pro, T-K3-SP/OS, T-H2-DV/OS, T-KJr2-IN/OS, T-K4-IN/OS, T-M50, T-M32
459	EKH30	Fastener "4-11"	T-K3, T-K3-Pro, T-H2-DV/OS, T-M50, T-M32
460	EKK24	Fastener "14-22"	T-K3, T-K3-Pro, T-K3-SP/OS, T-H2-DV/OS, T-KJr2-IN/OS, T-K4-IN/OS

Item #	Part #	Description	Common parts for other models
461	EM192	Fastener "16A"	T-K3, T-K3-Pro, T-K3-SP/OS, T-KJr2-IN/OS, T-K4-IN/OS
462	EKK39	Fastener "16-25A"	T-K3, T-K3-Pro
463	EKN50	Silicon ring	T-K3, T-K3-Pro, T-K3-SP, T-H2-DV, T-KJr2-IN/OS, T-K4-IN/OS, T-M32
701	EK439	Computer board	
702	EKH09	Transformer	T-K3, T-K3-Pro, T-K3-SP/OS, T-KJr2-IN/OS, T-K4-IN/OS
703	EK428	Surge box	T-KJr2-IN/OS, T-K4-IN/OS
704	EKK3C	120VAC wire	T-K3-SP/OS, T-H2-DV/OS, T-K4-IN/OS
705	EK440	Transformer wire	T-K4-IN/OS
706	EKK4V	120 VAC Power ON-OFF switch	T-K3-SP/OS, T-H2-DV/OS, T-KJr2-IN/OS, T-K4-IN/OS
707	EK441	Switch wire	T-K4-IN/OS
708	EKK10	Gas valve wire	T-K3, T-K3-Pro
709	EKK11	Flame rod wire	T-K3, T-K3-Pro
710	EKK0Z	EH-IG wire	T-K3, T-K3-Pro
	EKK40	EH-IG wire with freeze protection thermostat	T-K3-OS, T-KJr2-OS, T-K4-OS
711	EKN74	Igniter	T-K3, T-K3-Pro, T-K3-SP/OS, T-H2-DV/OS, T-KJr2-IN/OS, T-K4-IN/OS, T-M50, T-M32
712	EKK2M	High voltage igniter cable	T-K3, T-K3-Pro, T-K3-SP/OS, T-H2-DV/OS, T-KJr2-IN/OS, T-K4-IN/OS, T-M50
713	EKJ59	Freeze protection thermostat	T-K3, T-K3-Pro, T-K3-SP, T-KJr2-IN, T-K4-IN, T-M32
714	EKK12	Proportional gas valve wire	T-K3, T-K3-Pro, T-H2-DV/OS
715	EKK36	Pump and multi cable	T-K3, T-K3-Pro
716	EKK1Z	Thermistors wire	T-K3, T-K3-Pro
717	EKK35	RS-VG wire	T-K3, T-K3-Pro
718	EKK33	Water valves wire	T-K3, T-K3-Pro
719	EKK1M	Computer board cover	T-K3, T-K3-Pro, T-M50