

Single stage operation oil burner

**WARNING**

NON-RETROFIT APPLICATIONS

If this burner is being installed in a packaged unit (ie. burner comes with a boiler or furnace), follow the installation and set-up instructions supplied with the heating unit, as settings may differ from those shown in this manual.

- *The following pages contain information, descriptions and diagrams for the proper installation and wiring of the burner. Please read carefully before attempting final installation.*
- *This manual is to remain with the final installation designation. It is the installer's responsibility to ensure that the burner installation and operation instructions mentioned in this manual are followed and operated within local code authority limits.*

RIELLO 40

CODE	MODEL	TYPE
3726512	F20 WITH HYDRAULIC JACK	265T



INSTALLATION PRECAUTIONS

AIR FOR COMBUSTION

Do not install burner in room with insufficient air for combustion. Be sure there is an adequate air supply for combustion if the boiler/furnace room is enclosed. It may be necessary to create a window to permit sufficient air to enter the boiler/furnace room. The installer must follow local ordinances in this regard.

CANADA It is suggested that the installer follow CSA standard B139.

USA It is suggested that the installer follow NFPA manual #31.

CHIMNEY

Be sure chimney is sufficient to handle the exhaust gases. It is recommended that only the burner be connected to the chimney. Be sure that it is clean and clear of obstructions.

OIL FILTER

An external oil filter is **REQUIRED**, even though there is an internal strainer in the pump. The filter should be replaced at least once a year, and the filter container should be thoroughly cleaned prior to installing a new filter cartridge.

DRAFT

Follow the instructions furnished with the heating appliance. The pressure in the combustion area should be kept as close to zero as possible. The burner will operate with a slight draft or pressure in the chamber.

ELECTRICAL CONNECTIONS

CANADA All electrical connections should be done in accordance with the C.E.C. Part 1, and all local codes. The system should be grounded.

USA All electrical connections should be done in accordance with the National Electrical Code, and all local ordinances. The system should be grounded.

CONTROL BURNER OPERATION

Check out the burner and explain its operation to the homeowner. Be sure to leave the Owner's Instruction sheet with the homeowner.

FIRE EXTINGUISHER

If required by local codes, install an approved fire extinguisher.

ELECTRICAL CONNECTIONS

In most localities, a number 14 wire should be used inside a metal conduit. The system should be grounded. A service switch should be placed close to the burner on a fireproof wall in an easily accessible location.

TABLE OF CONTENTS

PACKAGE CONTENTS LIST	1
SERIAL NUMBER IDENTIFICATION	1
TECHNICAL DATA	2
Specifications	2
Burner and mounting flange dimensions	2
Burner components identification	2
Burner components	2
INITIAL SET-UP	3
ASSEMBLY OF AIR TUBE TO BURNER CHASSIS	3
MOUNTING BURNER TO BOILER OR FURNACE	3
Method 1-Universal Mounting Flange.	3
Method 2-Semi-flange Collar	4
Method 3-Pedestal Mount.	4
ELECTRICAL CONNECTIONS	5
APPLICATION FIELD WIRING	5
NOZZLE PLACEMENT	6
INSERTION / REMOVAL OF DRAWER ASSEMBLY	6
ELECTRODE SETTING	6
TURBULATOR SETTING	6
OIL LINE CONNECTIONS	7
Two line (Lift system)	8
PUMP PURGE	8
Two line (Gravity or lift system)	8
AIR SHUTTER SETTING	9
Low fire Setting	9
Main Flame Setting	9
BURNER SET-UP CHART	10
DUCTED COMBUSTION AIR INTAKE APPLICATIONS	11
BURNER START-UP CYCLE	12
EXPLODED SPARE PARTS LIST	13
SPARE PARTS LIST	14
BURNER START-UP REPORT	15

PACKAGE CONTENTS LIST

Your Riello 40 burner should include the following parts. Please check to make sure all parts are present before beginning the installation.

Quantity	Description	Code
1	Burner chassis with cover	3726512
1	Universal mounting flange + mounting gasket	2567395
1	Parts bag	2566283
1	Parts bag	2567338
1	Installation manual	2902453
1	By-pass plug	
1	Separate carton - OEM burners shipped with combustion head mounted	
1	Air Tube/Drawer Assembly	

Parts bag 2566283

Quantity	Description
1	Female 1/4" NPT adapter
1	Male 3/8" NPT adapter
1	Oil pump connector (supply)
1	Oil pump connector (return)
2	Mounting flange bolts (short)
2	Nuts
2	Chrome nuts

Parts bag 2567338

Quantity	Description
2	Semi-flange bolts (long)
2	Semi-flange
2	Cover screws
2	Nuts

SERIAL NUMBER IDENTIFICATION

Your Riello burner may have been manufactured in more than one location and therefore there are two possible serial number identification.

The Riello 9 character serial number, example,

06 01 12345, is identified as follows:

- 06** = Last two digits of the year of manufacture;
- 01** = Week of manufacture;
- 12345** = Increment of 1 for each burner produced – specific to product code – reset to zero each January 1st.

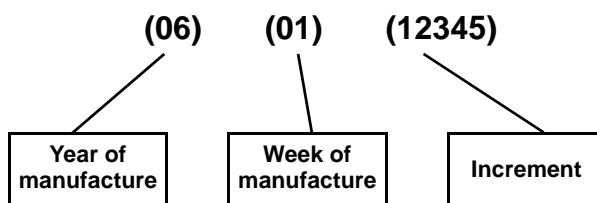

The Riello 15 character serial number, example,

06 A 8511111 00025, is identified as follows:

- 06** = Last two digits of the year of manufacture;
- A** = BI-week of manufacture;
- 8511111** = Burner product code;
- 00025** = Increment of 1 for each burner produced – specific to product code – reset to zero each January 1st.

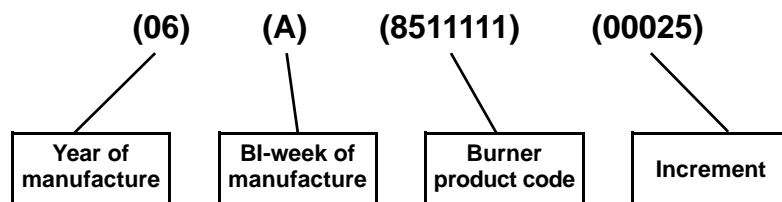

TECHNICAL DATA SPECIFICATIONS

Fuel	No. 2 Fuel Oil
Firing rate	3.50 to 6.40 GPH 11.3 to 20.7 kg/h
Effective output	490,000 to 896,000 BTU/h - 143.5 to 262.5 kW 123,480 to 225,790 kcal/h
Voltage (single phase)	120V 60Hz (+ 10% - 15%)
Absorbed electrical power	465 Watts
Motor (rated)	3250 rpm Run Current 4.3 AMP
Capacitor	16 Microfarads 260V
Pump pressure	100 to 200 psi
Primary control	RIELLO 530 SE/C 24V
Ignition transformer	8kV 16mA

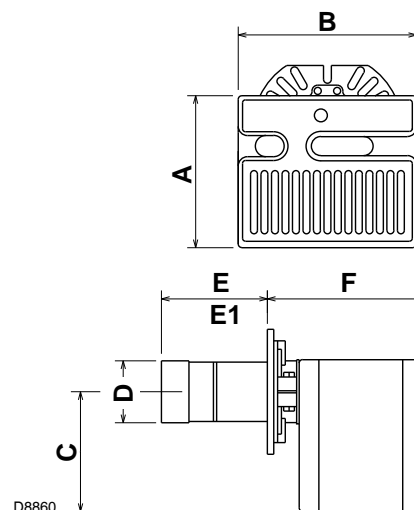

BURNER AND MOUNTING FLANGE DIMENSIONS

Model F20	A	B	C	D	E	F	G	H	I	L
Inches	11 3/4	13 25/32	9 1/16	4 11/16	5	11 27/32	1 1/2	1/4	7/16	2 7/8
mm	298	350	230	119	127	301	38	6	11	73

E1: 10-inch long (254mm) tubes are also available.

BURNER COMPONENTS IDENTIFICATION

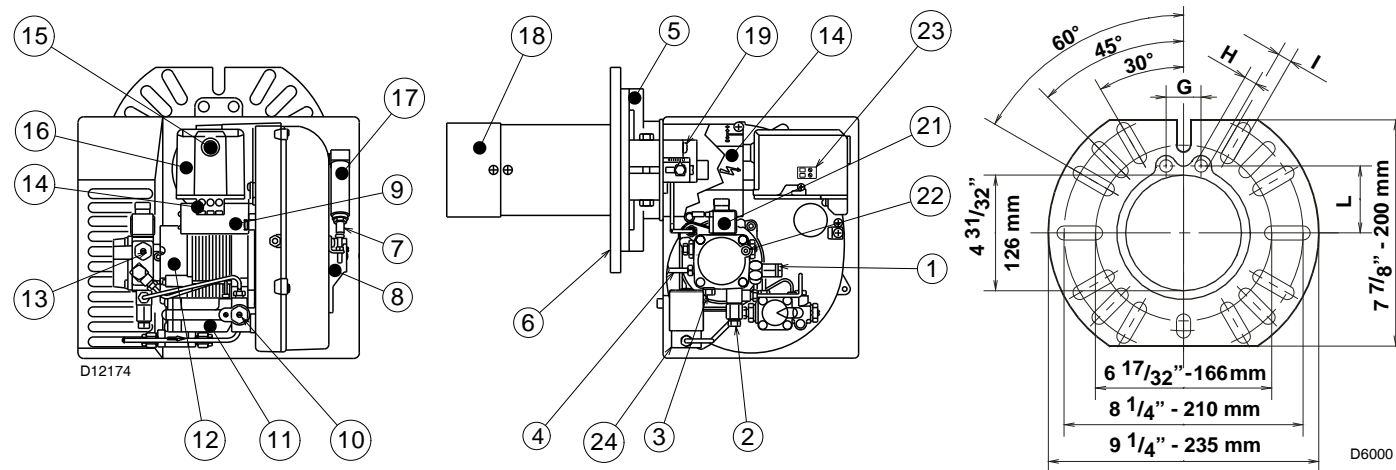

BURNER COMPONENTS

- | | |
|--|---|
| 1 Pressure gauge connection port | 13 Pump pressure regulator adjustment screw |
| 2 Return fuel line port | 14 Primary control sub-base |
| 3 Inlet fuel line port | 15 Lockout indicator lamp and reset button |
| 4 Capillary tube | 16 Primary control |
| 5 Adjustable collar | 17 Hydraulic jack |
| 6 Mounting flange with gasket | 18 End cone |
| 7 Air adjustment fixing screws | 19 Turbulator adjustment screw |
| 8 Hydraulic air shutter | 20 Air tube cover |
| 9 Capacitor | 21 Coil |
| 10 Fuel pressure adjustment screw low fire | 22 Vacuum gauge connection port |
| 11 Hydraulic delay valve low fire start | 23 24V thermostat connections |
| 12 Motor | 24 Solenoid valve |

INITIAL SET-UP

- A) Remove burner and air tube from cartons. Check parts list (inside cover) to ensure all parts are present.
- B) Remove burner cover by loosening the three screws securing it. Remove control box and air tube cover.
- C) Remove drawer assembly from air tube, insert nozzle and set Turbulator adjustment for specific input required, then set aside.
- D) Mount air tube to burner chassis.

ASSEMBLY OF AIR TUBE TO BURNER CHASSIS

The air tube and drawer assembly are shipped in a carton separate from the burner chassis. Choose the proper air tube length to obtain the tube insertion for the specific installation.

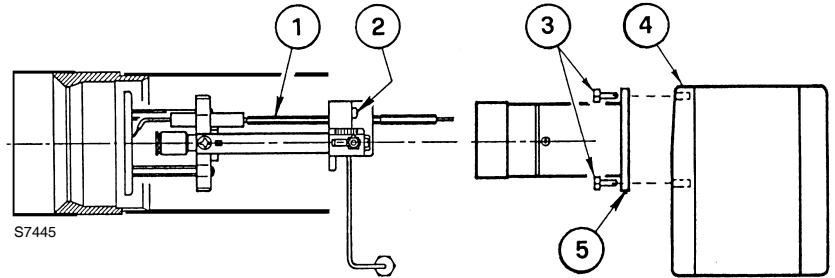

A) Remove the AIR TUBE and BURNER CHASSIS from their respective cartons.

B) Remove the DRAWER ASSEMBLY (1) from inside the AIR TUBE by loosening the screw (2). Carefully pull the DRAWER ASSEMBLY out of the AIR TUBE, install the required nozzle (see page 7) and set aside.

C) Align the two holes on the AIR TUBE HOLDING PLATE (5) with the two holes left open on the BURNER CHASSIS FRONT PLATE (4) with the BOLTS (3) removed.

Replace the BOLTS and finger tighten only. Re-install DRAWER ASSEMBLY into AIR TUBE. Tighten SCREW (2) securely (see page 7).

D) Tighten the two bolts (3) securely.

MOUNTING THE BURNER TO THE BOILER OR FURNACE

There are three possible methods to mount the burner, depending on the individual application. These are:

- 1) Universal flange bolted to Boiler/Furnace unit.
- 2) Semi-flange collar bolted to Boiler/Furnace unit.
- 3) Universal flange mounted to optional Pedestal mount, where flange mounting direct to appliance is not possible. Pedestal kit must be ordered separately.

METHOD 1 – UNIVERSAL MOUNTING FLANGE

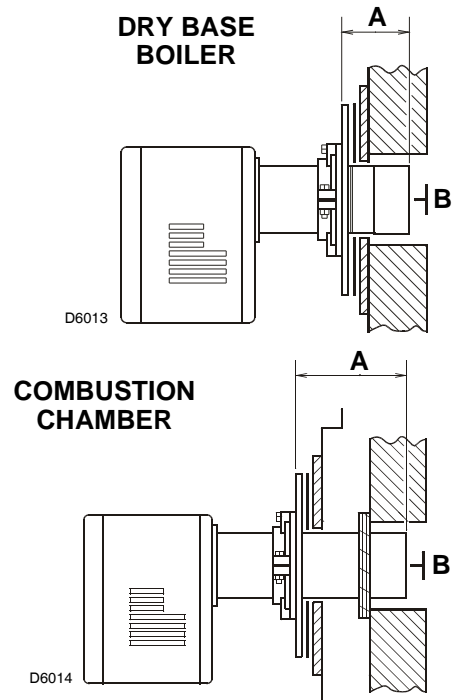
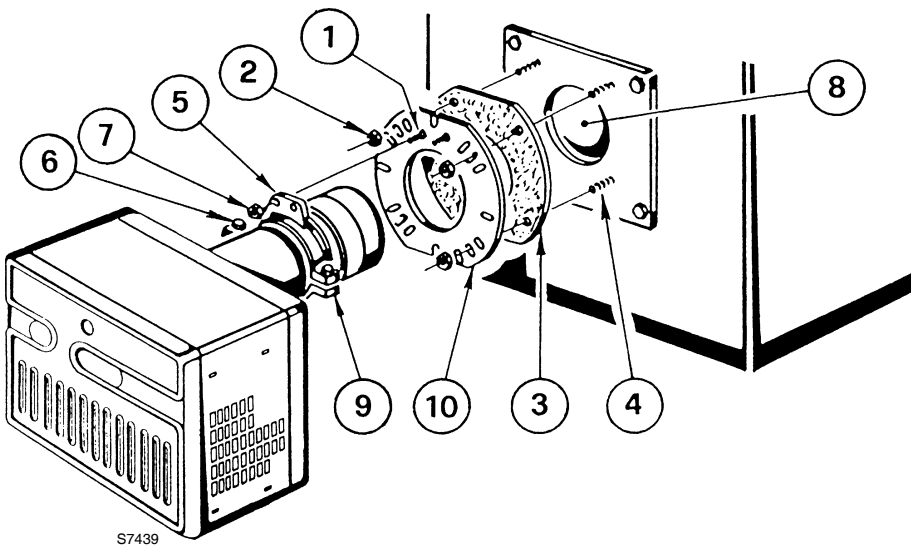

- A) Insert the two BOLTS (1) into the UNIVERSAL MOUNTING FLANGE (10) from the flat side, ensuring the bolt heads are flush with the flat surface. Secure in place using two special CHROME NUTS (2) provided.
- B) Position the MOUNTING GASKET (3) between the flat surface of the UNIVERSAL MOUNTING FLANGE (10) and the appliance. Line up the holes in the UNIVERSAL MOUNTING FLANGE with the STUDS (4) on the appliance mounting plate and securely bolt the UNIVERSAL MOUNTING FLANGE to the plate.
- C) Secure the two semi-flanges of the ADJUSTABLE COLLAR (9) to the AIR TUBE using the two long BOLTS (6). Be sure that the ADJUSTABLE collar is properly positioned so the outside edge of the END CONE will be at least 1/4 inch (6.5 mm) back from the inside wall of the refractory of the combustion chamber (see dimension **B**). The measured length (**A**), is to include MOUNTING GASKET and FLANGE, if used.
- D) The burner may now be attached to the heating unit by inserting the AIR TUBE through the BURNER ACCESS HOLE (8) and into the appliance, making sure the BOLTS (1) line up with the two HOLES (5) in the ADJUSTABLE COLLAR. Secure the burner in place using two NUTS (7).

A visual verification of the air tube insertion into the combustion chamber of the heating unit is suggested. Dimension B should be at least 1/4" (see drawing).

NOTE:

A suggested method for creating mounting bolt holes in the mounting gasket: Hold the gasket against the appliance mounting bolts using the mounting flange for proper positioning. Lightly tap the flange with a hammer to form the holes.

METHOD 2 – SEMI-FLANGE COLLAR

- A) Follow item C from METHOD 1.
- B) Align the air tube and attached adjustable collar so air tube is centered in the burner access hole of the boiler/furnace unit. Mark the center of the two holes in the ADJUSTABLE COLLAR on to the front plate of the heating unit. Then drill 1/4 inch (6.5 mm) holes through the front plate of the unit, using marks as a guide.
- C) Install two short BOLTS (1) through the front plate of the heating unit from the inside, and secure on the outside using the two special CHROME NUTS (2).
- D) Follow item D from METHOD 1.

METHOD 3 – PEDESTAL MOUNT

Secure the MOUNTING FLANGE to MOUNTING PEDESTAL using the hardware provided with the pedestal. Secure burner to MOUNTING FLANGE as in METHOD 1, items A, C and D.

NOTE:

It is suggested that the pedestal be anchored in position on the floor by installing brackets over the pedestal tube and securing brackets to the floor.



WHEN THE COMBUSTION CHAMBER IS LINED WITH A REFRACTORY MATERIAL, IT IS IMPERATIVE THAT THE END CONE NOT PROTRUDE INTO THE CHAMBER AREA, AS EXCESSIVE HEAT AT BURNER SHUT DOWN WILL DAMAGE THE END CONE.

ELECTRICAL CONNECTIONS

It is advisable to leave the control box off the sub-base while completing the electrical connections to the burner.

- 1) Wire access hole (Use BX electrical connector)
- 2) Earth ground conductor terminal (GREEN WIRE)
- 3) Hot conductor terminal (BLACK WIRE)
- 4) Neutral conductor terminal (WHITE WIRE)
- 5) Strain relief clamp

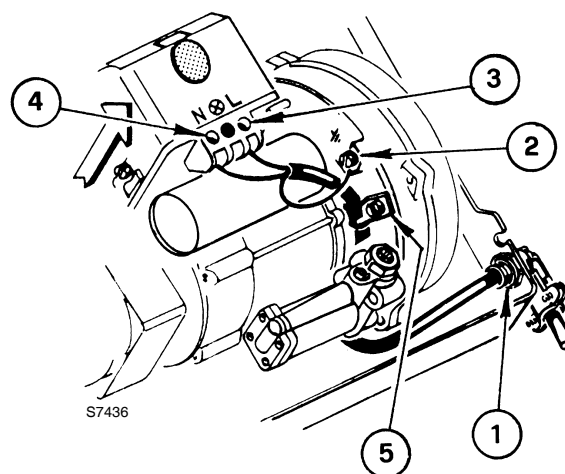

WARNING:

The hot (black) wire must be connected to the L terminal and the neutral (white) wire must be connected to the N terminal or the primary safety control will be damaged.
Do not connect wither wire to the terminal marked ⊗.

The burner may be controlled using either a DIRECT LINE VOLT-AGE control circuit (120V AC 60 cycle) OR:

- a LOW VOLTAGE thermal input (T-T) if the primary control 530SE/C 24V is used.

Using the appropriate diagram below, make electrical connections to burner. All wiring must be done in accordance with existing electrical codes, both national and local.

When all electrical connections have been made, the control box may be put back in place on the sub-base.

WARNING: DO NOT activate burner until proper oil line connections have been made, or failure of the pump shaft seal may occur.

DIRECT LINE VOLTAGE

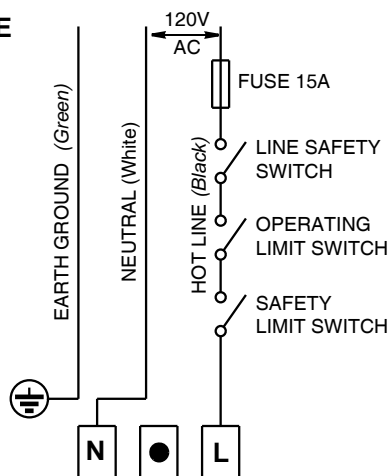

LOW VOLTAGE

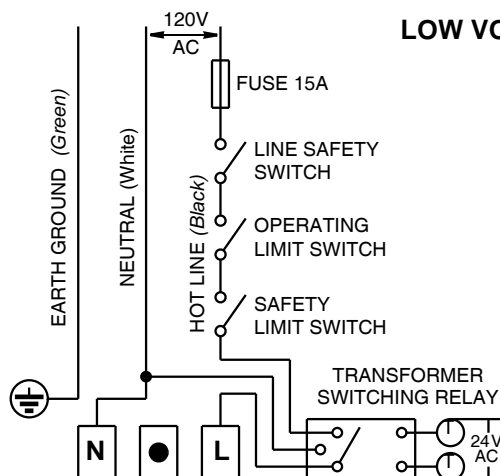

FACTORY WIRED SUB-BASE

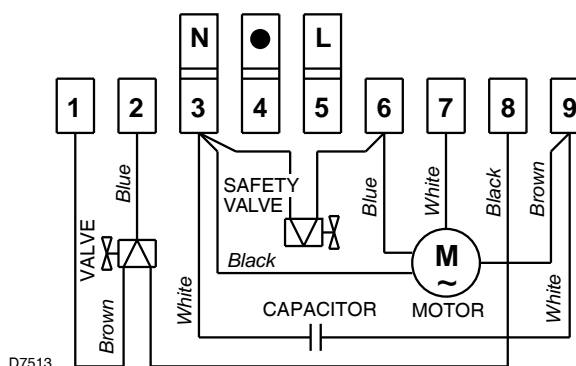

NOTE: Terminal 4 is to be used to activate a remote safety lockout circuit only. A 120V AC source is supplied to Terminal 4 upon lockout. The maximum allowable current draw for this circuit is 1 AMP.

IMPORTANT: if a neutral or ground lead is attached to Terminal 4, the control box will be damaged should lockout occur.

NOZZLE PLACEMENT

- Determine the proper firing rate for the boiler or furnace units, considering the specific application, and then use the Burner Setup Charts to select the proper nozzle and pump pressure to obtain the required input from the burner.
- Remove the NOZZLE ADAPTER (2) from the DRAWER ASSEMBLY by loosening the SCREW (1).
- Insert the proper NOZZLE into the NOZZLE ADAPTER and tighten securely (Do not over tighten).
- Replace adapter, with nozzle installed, into drawer assembly and secure with screw (1).

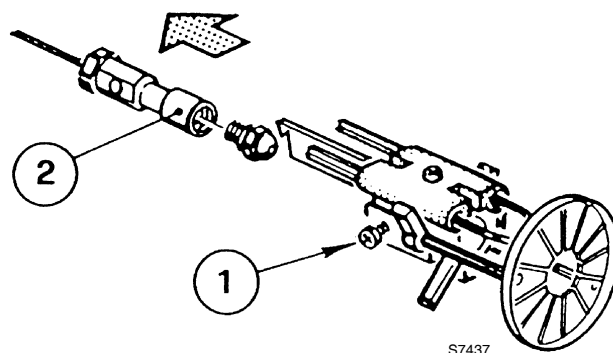

INSTALLATION/REMOVAL OF DRAWER ASSEMBLY

- To remove drawer assembly, loosen SCREW (3), then unplug CONTROL BOX (1) by carefully pulling it back and then up.
- Remove the AIR TUBE COVER PLATE (5) by loosening the two retaining SCREWS (4).
- Loosen SCREW (2), then slide the complete drawer assembly out of the combustion head as shown.
- To insert drawer assembly, reverse the procedure in items A to C above, then attach fuel line to the pump.

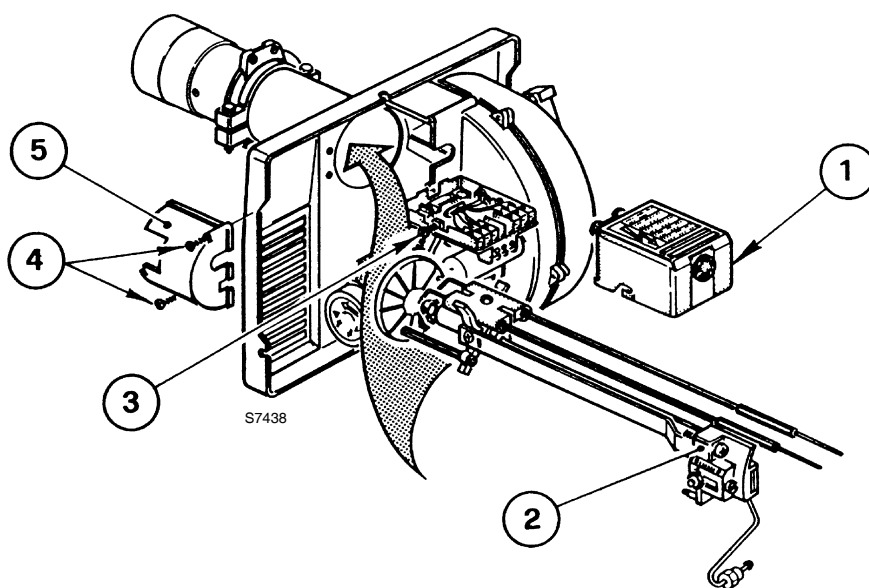

ELECTRODE SETTING

IMPORTANT:

These dimensions must be observed and verified.

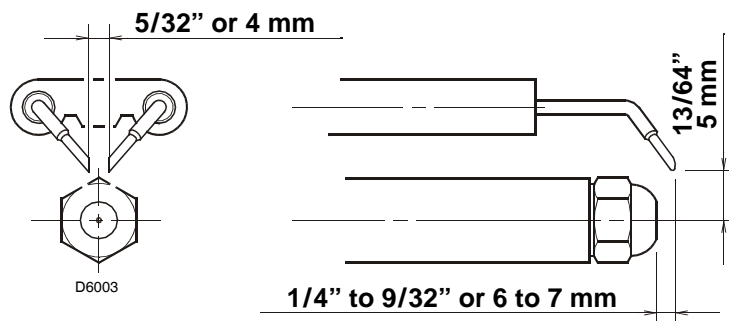

TURBULATOR SETTING

- Loosen NUT (1), then turn SCREW (2) until the INDEX MARKER (3) is aligned with the correct index number as per the Burner Set-up chart.
- Retighten the RETAINING NUT (1).

NOTE:

Zero and five are scale indicators only. From left to right, the first line is 5 and the last line 0.

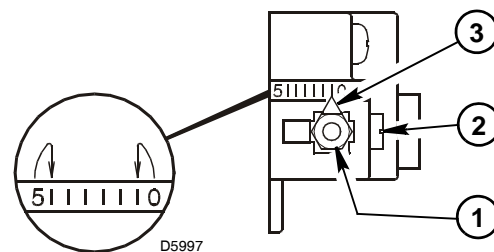

OIL LINE CONNECTIONS

WARNING:

The burner is shipped from the factory with the pump set to operate on a TWO line system.

NOTE:

- THIS BURNER **MUST** BE INSTALLED WITH A TWO LINE SYSTEM TO ALLOW THE HYDRAULIC DELAY VALVE TO OPERATE.
- Pump pressure **must** be set at time of burner start-up. A pressure gauge is attached to the PRESSURE PORT (1) for pressure readings.

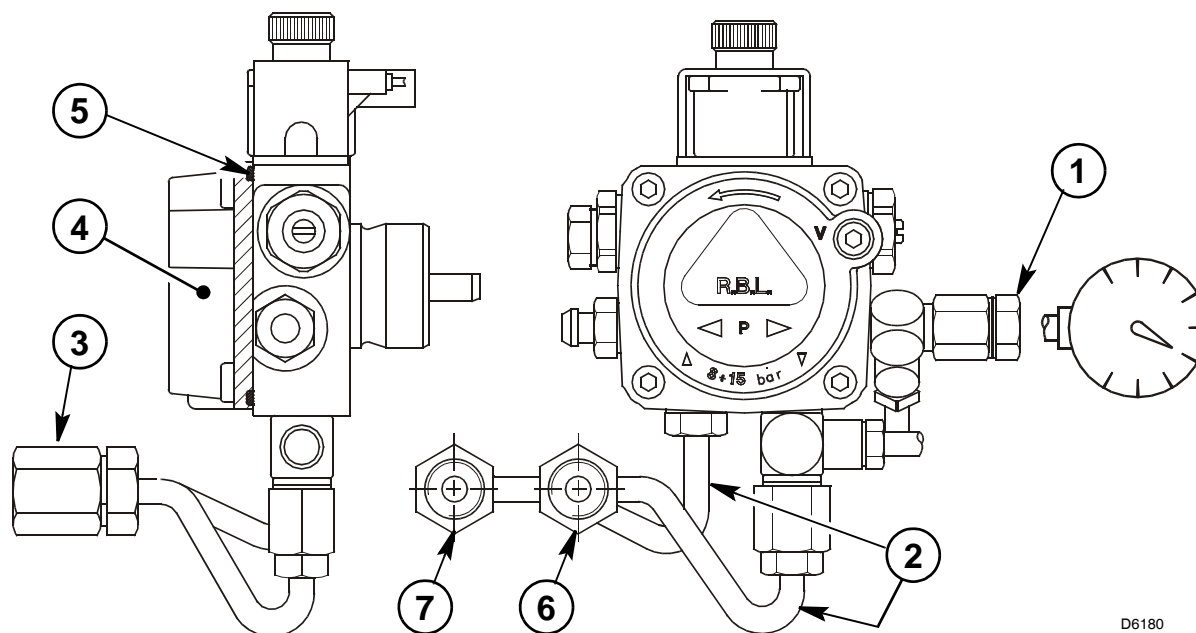

D6180

Two PIPE CONNECTORS (2) are supplied with the burner for connection to either a single or a two-pipe system. Also supplied are two adapters (3), two female 1/4" NPT, to adapt oil lines to burner pipe connectors. All pump port threads are **British Parallel thread design**. Direct connection of NPT threads to the pump will damage the pump body.

Riello manometers and vacuum gauges do **not** require any adapters, and can be safely connected directly to pump ports.

An NPT (metric) adapter **must** be used when connecting other gauge models.

NOTE:

If the **pump cover (4)** is removed for any reason, be sure the O-ring (5), is properly seated in the pump cover (4) before re-attaching the pump cover to the pump housing.

TWO LINE (LIFT SYSTEM)

A) The burner is shipped with the pump set to operate on a two line system. Suction and return lines (6 & 7 in drawing on page 7) should be the same diameter and both should extend to the same depth inside the fuel tank.

Be sure there are no air leaks or blockages in the piping system. Any obstructions in the return line will cause failure of the pump shaft seal. Do not exceed the pipe lengths indicated in the table.

B) Attach the two PIPE CONNECTORS (2) to the pump SUCTION and pump RETURN PORTS (6 and 7).

Attach the required piping to these two pipe connectors using the NPT/METRIC ADAPTERS that are supplied with the burner.

2 LINE (LIFT) SYSTEM - PIPE LENGTHS					
H		3/8" OD		1/2" OD	
Feet	Meters	Feet	Meters	Feet	Meters
0	0.0	115	35	330	100
1 1/2	0.5	100	30	330	100
3	1.0	80	25	330	100
5	1.5	65	20	295	90
6 1/2	2.0	50	15	230	70
9 1/2	3.0	25	8	100	30
11	3.5	20	6	65	20

WARNING:

- Pipe dope or Teflon tapes are NOT to be used on any direct oil connection to the fuel pump.
- The height 'P' in Pipe Length Charts should not exceed 13 feet (4 m).
- The vacuum should not exceed 11.44 inches of mercury.

IMPORTANT:

An external, appropriately listed and certified oil filter must be placed in the fuel line between the fuel tank and the burner pump.

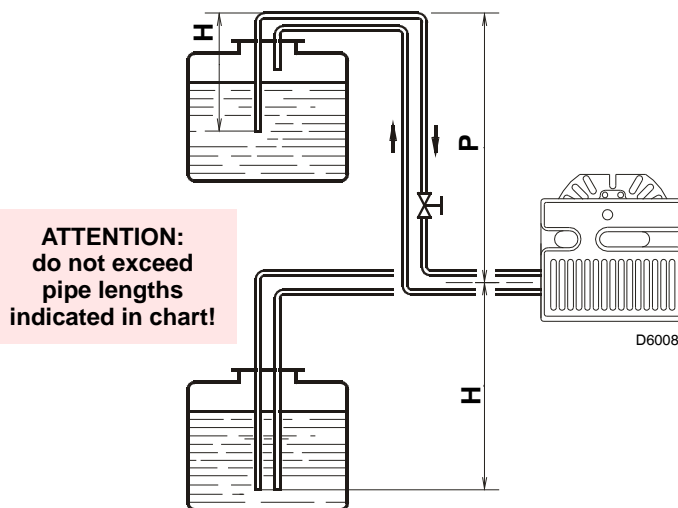

PUMP PURGE

TWO LINE (GRAVITY OR LIFT SYSTEM)

Turn off the main power source to the burner and remove the air tube cover. Shine a light source on the photo cell on the control box (now visible where the air tube cover was removed), return power to the burner and activate the burner.

With the light source in place, the burner will operate in prepurge only.

When the pump is sufficiently purged, the hydraulic air shutter will open.

Once the burner is purged, turn off the power source and replace the air tube cover. Return power to the burner. The burner is now ready to operate.

NOTE: To protect the pump gears, it is advisable to lubricate the pump prior to purging a lift system. Apply oil through the VACUUM PORT (A).

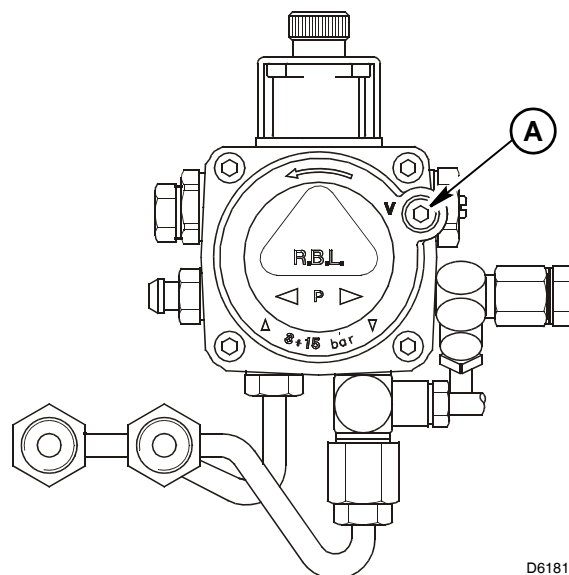

ATTENTION:

It is important that the fuel line be completely sealed and free from air leaks or any internal blockages.

WARNING!

WHEN THE BYPASS PLUG IS INSTALLED, A TWO PIPE SYSTEM MUST BE USED OR FAILURE OF THE PUMP SHAFT SEAL WILL OCCUR.

AIR SHUTTER SETTING

LOW FIRE SETTING

- A) Loosen PRESSURE RELEASING SCREW (1). (One turn is sufficient). This permits the fuel pressure to bleed off to the pump return port and the burner to operate continuously at the low fire rate.
- B) Loosen RETAINING NUT (2).
- C) Turn the ADJUSTING SCREW (3) until the top of the air shutter (9) is correctly positioned according to the Burner Set-up Chart, column 5, on page 12.
- D) Use instruments to establish the proper settings for maximum CO₂ and a smoke reading of zero.
- E) Hold ADJUSTING SCREW (3) in position and secure by tightening RETAINING NUT (2).
- F) Retighten PRESSURE RELEASE SCREW (1).

Note:

The low fire pressure regulator is pre-set at the factory to 100 PSI (7 bar).

To vary or regulate this pressure it is necessary to attach a pressure gauge to the PRESSURE PORT (6).

Loosen the PRESSURE RELEASE SCREW (1) as in step A above. Regulate the pressure by turning the PRESSURE REGULATING SCREW (5).

The corresponding pressure can be read on the pressure gauge attached to the PUMP PRESSURE PORT (6).

MAIN FLAME SETTING

- A) Be sure that the burner is operating at high fire.
- B) Set the pump pressure by attaching a pressure gauge to the Pressure port (6) and adjust the pressure by turning the pressure regulator adjustment screw (10).
Loosen the RETAINING NUT (7), and turn the BOLT (8) in a counterclockwise direction until about 3/4 of an inch of thread is visible. Using the setting taken from the Burner Set-up Chart, column 5, position the air shutter (9) so that the top of the shutter is aligned with the proper index line indicated on the air intake side of the burner housing. Holding the shutter in this position, turn ADJUSTING BOLT (8) in a clockwise direction until a resistance is met.
- C) The final position of the air adjustment plate will vary on each installation. Use instruments to establish the proper settings for maximum CO₂ and a smoke reading of zero.

NOTE:

Variations in flue gas, smoke, CO₂ and temperature readings may be experienced when the burner cover is put in place. Therefore, the burner cover **must** be in place when making the final combustion instrument readings, to ensure proper test results.

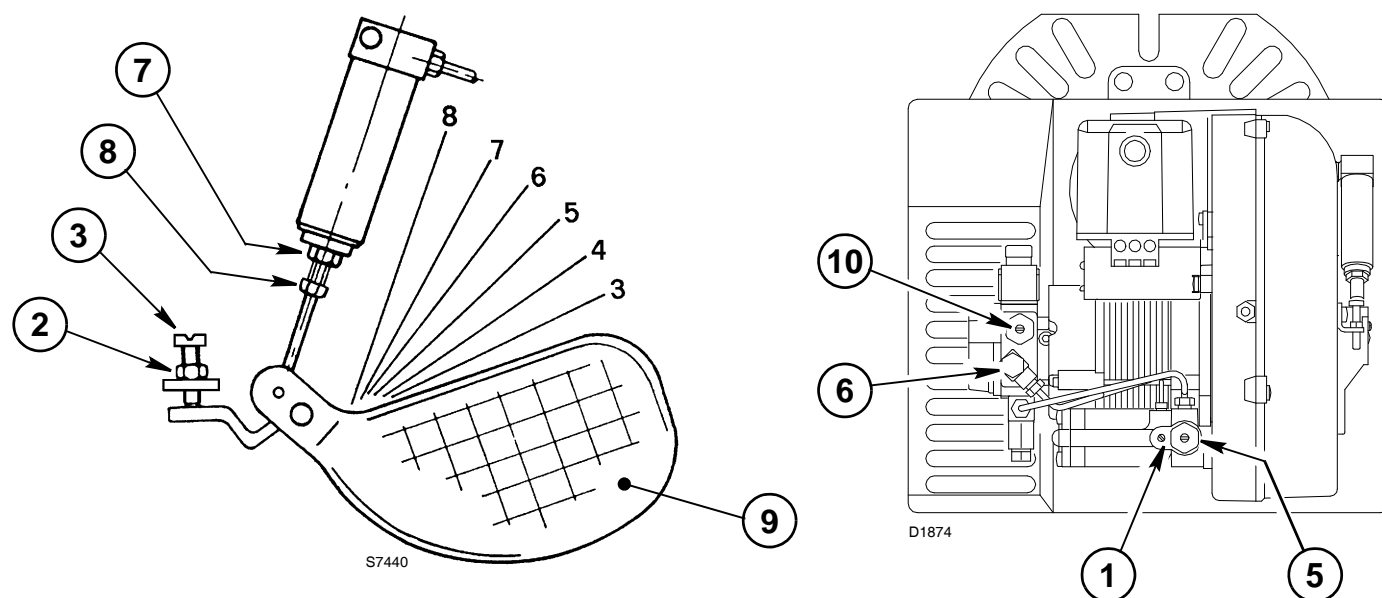

BURNER SET-UP CHART

NON-RETROFIT APPLICATIONS

If this burner is being installed in a packaged unit (ie. burner comes with a boiler or furnace), follow the installation and set-up instructions supplied with the heating unit, as settings will differ from those shown in this manual.

1		2	3		4	5	
Actual Firing Rate \pm 5%		Nozzle Size	Pump Pressure		Turbulator Setting	Air Damper Setting	
GPH	Kg/h	GPH	PSI	bar		Low Fire	Main Flame
3.50	11.3	2.50 x 45°/60°	190	13.0	0.0	2.3	2.8
4.00	12.9	3.00 x 45°/60°	178	12.0	1.0	2.5	3.2
4.65	15.0	3.50 x 45°/60°	178	12.0	2.0	2.8	3.7
5.30	17.1	4.00 x 45°/60°	178	12.0	3.0	3.2	4.5
6.00	19.4	4.50 x 45°/60°	178	12.0	4.0	3.5	5.0
6.40	20.7	5.00 x 45°/60°	165	11.4	5.0	3.8	6.0

NOZZLES RECCOMANDED:

Monarch R-PLP, Delavan W-B, Danfoss S-B, Steinen SS-S, Hago P.

NOTE:

A 45° degree nozzle is suggested, however, a 60° degree nozzle may be used in cases where the flame is unstable at light-off when operated at low ambient temperatures.

DUCTED COMBUSTION AIR INTAKE APPLICATIONS

The “Ducted combustion air intake kit” (see P.N. 3002762 in the spare parts list - OPTIONAL), allows ducting of external air directly into the burner. A 4” diameter air intake is provided in the kit.

To mount this kit on the burner, please follow the installation description given in the kit instruction sheet. Use a 4” to 6” pipe adapter (not supplied in the kit) to use a 6” diameter pipe.

The settings of the burner must be according to the BURNER SETUP CHART – AIR INTAKE APPLICATIONS below.

MODEL F20 BURNER SETUP CHART with 4" diameter pipe											
Actual firing rate GPH	Nozzle size	Pump pressure PSI	Head setting	20 Ft. pipe length		50 Ft. pipe length		80 Ft. pipe length		100 Ft. pipe length	
				Air setting		Air setting		Air setting		Air setting	
				Low fire	Main flame	Low fire	Main flame	Low fire	Main flame	Low fire	Main flame
3.50	2.50 x 45°/60°	195	0.5	2.3	2.9	2.3	2.9	2.3	3.0	2.5	3.0
4.00	3.00 x 45°/60°	177	2.0	2.4	3.1	2.4	3.3	2.4	3.5	2.6	3.8
4.65	3.50 x 45°/60°	176	3.5	2.9	3.9	3.0	4.2	3.0	4.5	3.5	5.0
5.16	4.00 x 45°/60°	160	5.0	3.1	4.8	3.2	5.0	3.3	5.0	3.8	5.8

MODEL F20 BURNER SETUP CHART with 6" diameter pipe											
Actual firing rate GPH	Nozzle size	Pump pressure PSI	Head setting	20 Ft. pipe length		50 Ft. pipe length		80 Ft. pipe length		100 Ft. pipe length	
				Air setting		Air setting		Air setting		Air setting	
				Low fire	Main flame	Low fire	Main flame	Low fire	Main flame	Low fire	Main flame
3.50	2.50 x 45°/60°	195	0.5	2.1	2.8	2.1	2.8	2.1	2.9	2.1	2.9
4.00	3.00 x 45°/60°	177	2.0	2.2	3.0	2.2	3.0	2.3	3.1	2.3	3.1
4.65	3.50 x 45°/60°	176	3.5	2.7	3.4	2.7	3.5	2.9	3.8	3.1	4.5
5.30	4.00 x 45°/60°	160	4.5	3.0	3.8	3.0	4.0	3.0	4.1	3.1	4.5
6.00	4.50 x 45°/60°	177	5.0	3.0	5.3	3.3	5.4	3.3	5.4	3.5	5.7

NOZZLES RECCOMANDED:

Monarch R-PLP, Delavan W-B, Danfoss S-B, Steinen SS-S, Hago P.

NOTE:

A 45° degree nozzle is suggested, however, a 60° degree nozzle may be used in cases where the flame is unstable at light-off when operated at low ambient temperatures.

NOTES:

- A) This kit is not suitable for direct vent applications.
- B) Always try to minimize the length of the air intake pipe.
- C) Reduce pipe length by 10 feet for every 90° elbow, 5 feet for every 45° elbow.
- D) Reduce pipe length by 6 feet for the 4” to 6” pipe adapter (if used).
- E) Air intake venting should be insulated 10 feet from air intake source with a minimum R7 foil lined insulation, to prevent condensation or corrosion of air intake venting.
- F) Use an approved type of air intake vacuum breaker and install it in the same room of the burner.
This device should be tested to prove that the vacuum breaker balancer is set correctly and, in the event of intake air source being blocked, can provide enough combustion air for the burner. If the room where the burner is installed cannot provide enough air or air quality is a concern, an additional air inlet source must be provided to this room.
- G) On the outside of the wall, use an approved intake air hood, located above the snow line and in such way as to prevent leaves and/or other debris from blocking the air flow. Refer to local codes for proper location of inlet.

COMBUSTION CHAMBER

Follow the instructions furnished by the boiler/furnace manufacturer. Size retrofit application according to the appropriate installation codes (eg. CSA B139 or NFPA #31).

BURNER START-UP CYCLE

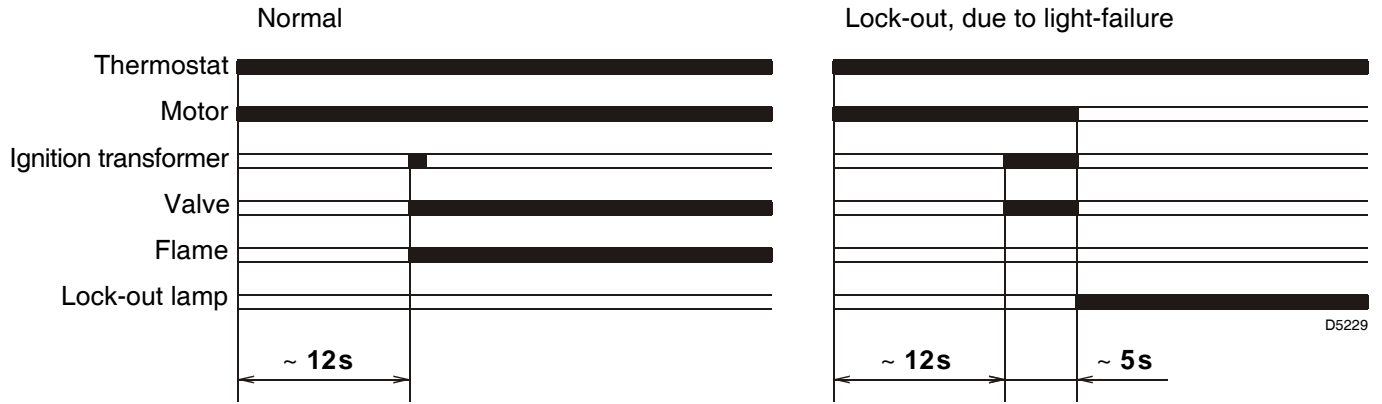

EXPLODED SPARE PARTS LIST

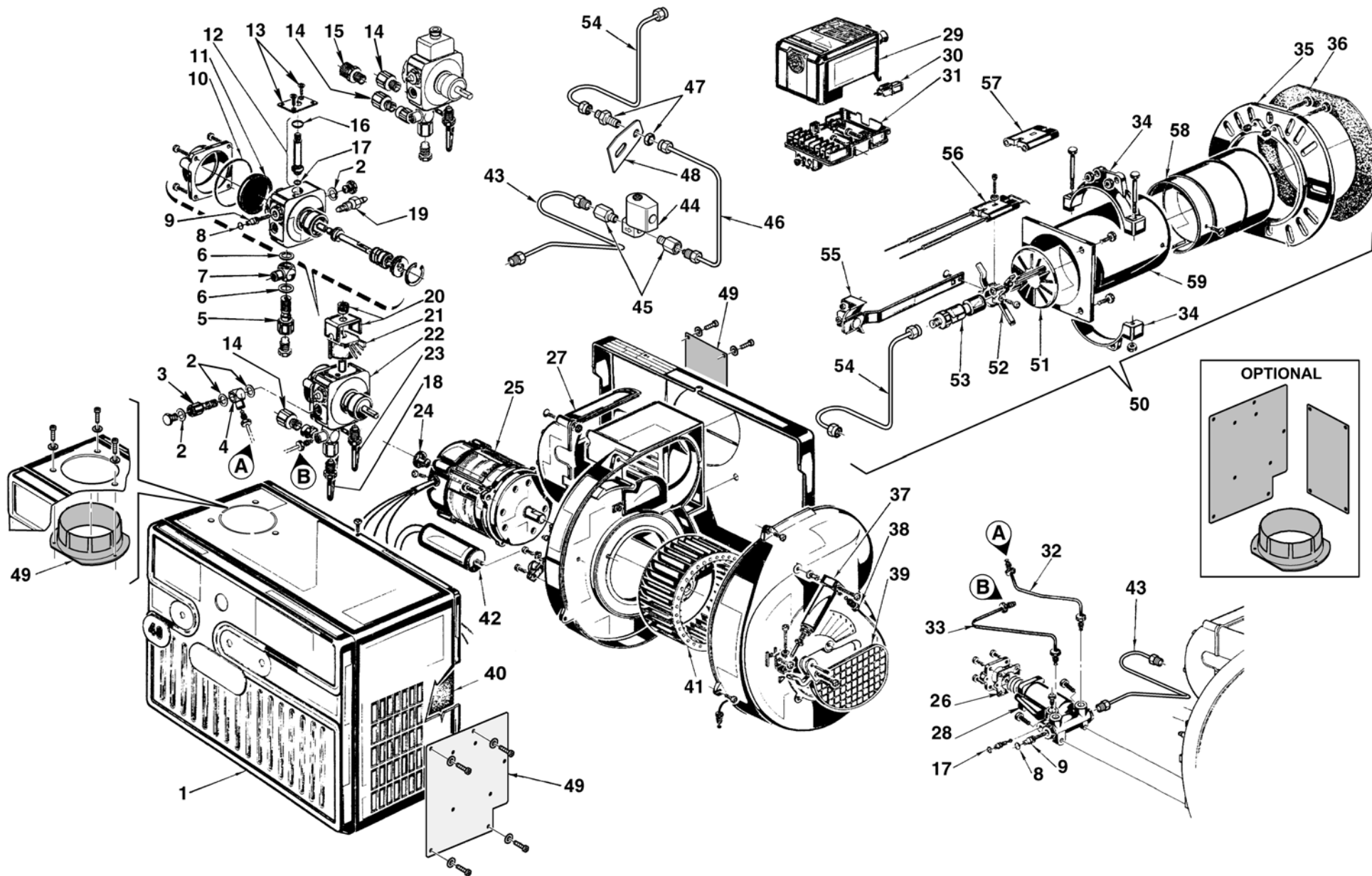

SPARE PARTS LIST

No.	CODE	DESCRIPTION	No.	CODE	DESCRIPTION
1	3020510	BURNER BACK COVER	43	3020313	OIL LINE
2	3007077	CRUSHABLE METAL WASHER	44	3020299	SOLENOID VALVE
3	3005771	BANJO CORE ADAPTER - PRESSURE PORT	45	3020304	ADAPTOR
4	3005803	BANJO FITTING - PRESSURE PORT	46	3020301	OIL LINE
5	3005804	BANJO CORE ADAPTER - RETURN LINE	47	3020303	ADAPTOR AND NUT
6	3007079	CRUSHABLE METAL WASHER	48	3020302	BRACKET
7	3005805	BANJO FITTING - RETURN			
8	3007028	O-RING - PUMP PRESSURE REGULATOR			OPTIONAL
9	3007202	REGULATOR SCREW	49	3002762	DUCTED COMBUSTION AIR INTAKE KIT
10	3007162	O-RING - PUMP COVER			
11	3005719	PUMP SCREEN			
12	3006925	VALVE STEM	50	3949271	SHORT COMBUSTION HEAD 5" (275T1)
13	3007203	VALVE STEM PLATE	51	3005897	TURBULATOR DISC
14	3005847	1/4" NPT/ METRIC ADAPTER - FEMALE	52	3005896	CROSS - CASTING
15	3006571	3/8" NPT/METRIC ADAPTER - MALE	53	3006965	NOZZLE ADAPTER
16	3007029	O-RING - VALVE STEM UPPER	54	3006987	NOZZLE OIL TUBE - SHORT
17	3007156	O-RING - VALVE STEM LOWER	55	3005900	REGULATOR ASSEMBLY - SHORT
18	3006995	PIPE CONNECTOR - RETURN	56	3005902	ELECTRODE ASSEMBLY - SHORT
19	3007893	BLEEDER	57	3005869	ELECTRODE PORCELAIN
20	3006553	COIL U-BRACKET AND KNURLED NUT	58	3005894	END CONE
21	3002279	COIL	59	3005892	SHORT AIR TUBE
22	3007806	PUMP			
23	3006994	PIPE CONNECTOR - SUPPLY	50	3949272	LONG COMBUSTION HEAD 10" (275T2)
24	3000443	PUMP DRIVE KEY	51	3005897	TURBULATOR DISC
25	3005845	MOTOR	52	3005896	CROSS - CASTING
26	3005801	GASKET	53	3006965	NOZZLE ADAPTER
27	3007318	AIR TUBE COVER	54	3006988	NOZZLE OIL TUBE - LONG
28	3006500	HI FIRE DELAY VALVE	55	3005901	REGULATOR ASSEMBLY - LONG
29	3001157	PRIMARY CONTROL 530SE/C	56	3005903	ELECTRODE ASSEMBLY - LONG
30	3002280	PHOTO-CELL	57	3005869	ELECTRODE PORCELAIN
31	3002278	PRIMARY CONTROL SUB BASE	58	3005894	END CONE
32	3005809	OIL PRESSURE TUBE	59	3005893	LONG AIR TUBE
33	3005808	OIL RETURN TUBE			
34	3005849	SEMI FLANGE			
35	3005851	UNIVERSAL MOUNTING FLANGE			
36	3005852	MOUNTING GASKET			
37	3006499	HYDRAULIC JACK			
38	3008050	CAPILLARY TUBE			
39	3000645	HYDRAULIC AIR SHUTTER			
40	3007358	ACOUSTIC LINER			
41	3005799	FAN			
42	3005846	CAPACITOR 16 µF			

BURNER START-UP REPORT

Model number: _____	Serial number: _____
Project name: _____	Start-up date: _____
Installing contractor: _____	Phone number: _____

LIGHT OIL OPERATION			
Oil supply pressure: _____	CO ₂ : Low Fire _____	High Fire _____	
Oil suction pressure: _____	O ₂ : Low Fire _____	High Fire _____	
Control Power Supply: _____	CO: Low Fire _____	High Fire _____	
Burner Firing Rate: _____	NO _x : Low Fire _____	High Fire _____	
Low Fire Flame Signal: _____	Net Stack Temp - Low Fire: _____	High Fire _____	
High Fire Flame Signal: _____	Comb. Efficiency - Low Fire: _____	High Fire _____	
Low Fire Nozzle Size: _____	Overfire Draft: _____		
High Fire Nozzle Size: _____	Smoke number: _____		

CONTROL SETTINGS			
Operating Setpoint: _____	Low Oil Pressure: _____		
High Limit Setpoint: _____	High Oil Pressure: _____		
Low Gas Pressure: _____	Flame Safeguard Model Number: _____		
High Gas Pressure: _____	Modulating Signal Type: _____		

NOTES

RIELLO

RIELLO S.p.A.
I-37045 Legnago (VR)
Tel.: +39.0442.630111
[http:// www.riello.it](http://www.riello.it)
[http:// www.rielloburners.com](http://www.rielloburners.com)

RIELLO

35 Pond Park Road
Hingham, Massachusetts,
U.S.A. 02043

RIELLO BURNERS NORTH AMERICA

1-800-4-RIELLO

1-800-474-3556

<http://www.riello-burners.com>

2165 Meadowpine Blvd
Mississauga, Ontario
Canada L5N 6H6